



# Bowsmith Pro II and Bowsmith II



# Bowsmith Assembly

Your machine was assembled and test shot at the factory. It will go back together with no modifications. If you find you cant assemble witout changing set up please call. 815 325 9128

**Remember to keep away from the front of the machine, never stand in front of the machine. Keep your hands and fingers out of the way. Keep your kids away. Check for loose bolts and always pay attention to what you are doing.**

Scan with phone camera for set up and use video for the bowsmith pro



**This is how your machine arrives.**



**Contents of the small box**

**Winch handel, 2- L wrenches, Hardware package, Bow hand holder / torque box and release carriage**

# Contents of the long inner box



Front and rear leg and 2 feet.



Upper limb brace



forward brace for the paper tuner



Paper tuner assembly

Build the leg assembly first.

Identify the front and rear legs, as you can see in the pics the front leg has A knob on its side

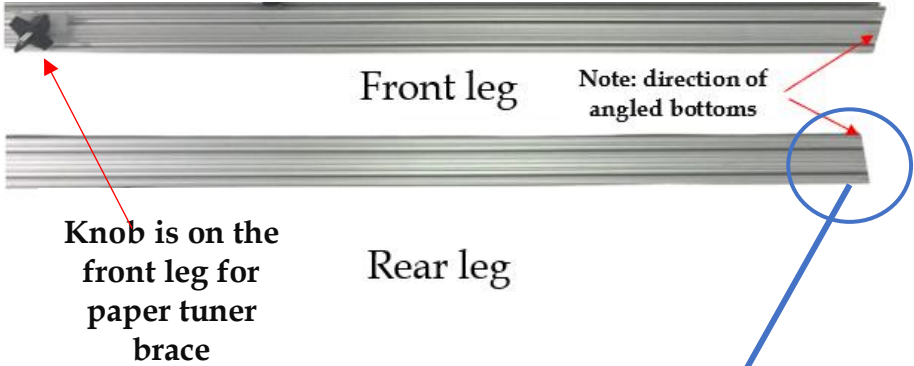

Install feet brackets on each side of the legs

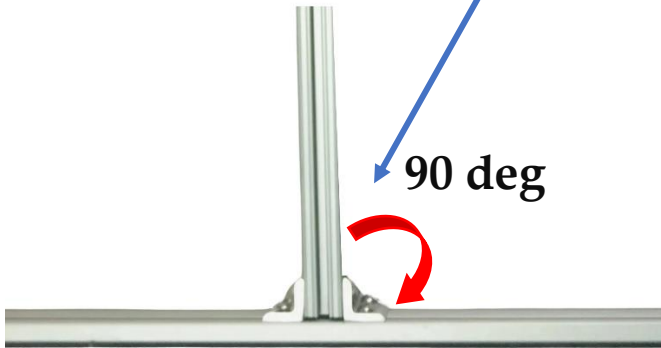

Slide foot in place.

Try and keep it square.

Do the same thing with the front leg.

If you ordered the leg brace kit install it now.

## Rear leg

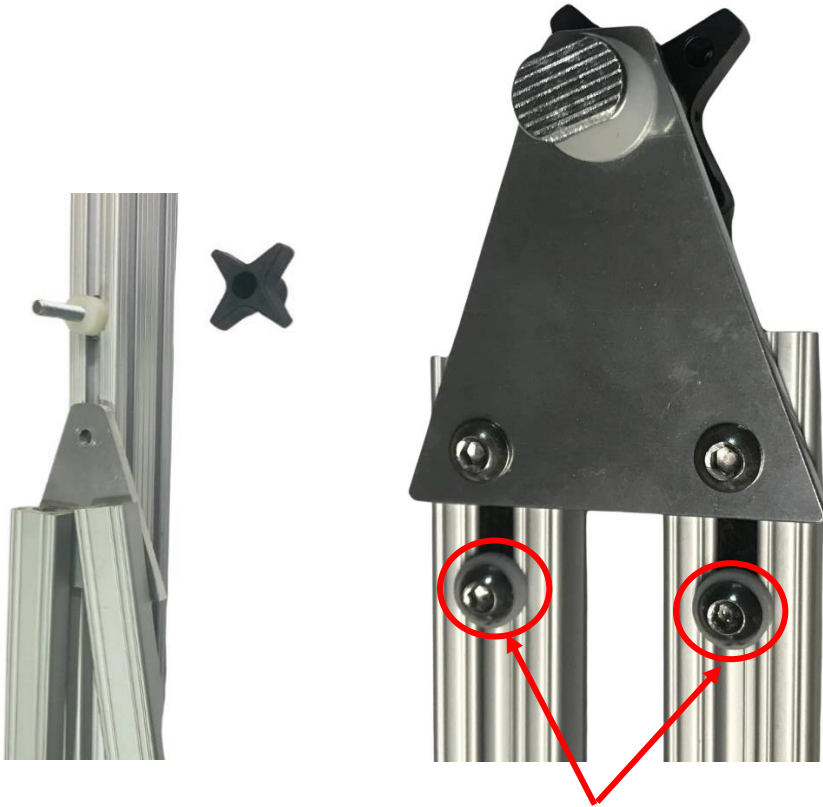

**Do not loosen  
these to install.**

Leave the washer in place and slide bracket over the bolt and loosely install the knob on the rear leg. Attach the feet brackets in place to look like the pic.

**Do not  
loosen  
these to  
install.**

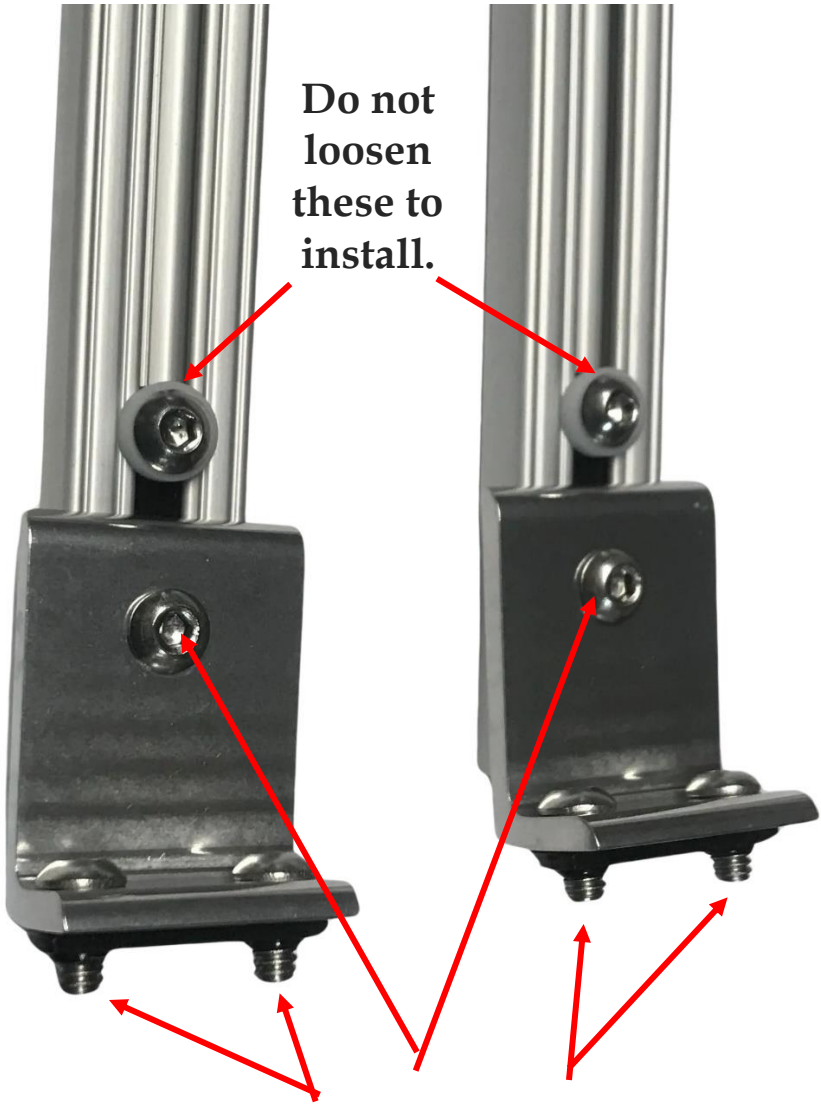

**Loosen to install.  
Slide into feet**



Do the same thing with the front leg.



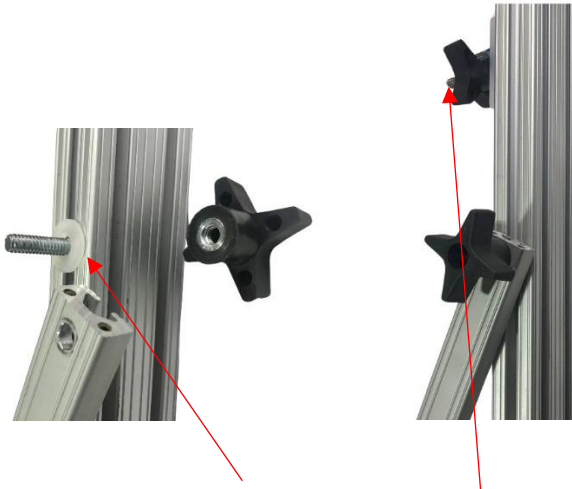

Make sure this washer stays in place. Do not remove the other knob, it will need to stay in place as seen in pic.



This knob is on the pro only. And is used to brace the paper tuner.

With the 2 leg assemblies complete -  
mount to the main frame making sure  
the front and rear go into their  
respective spots.

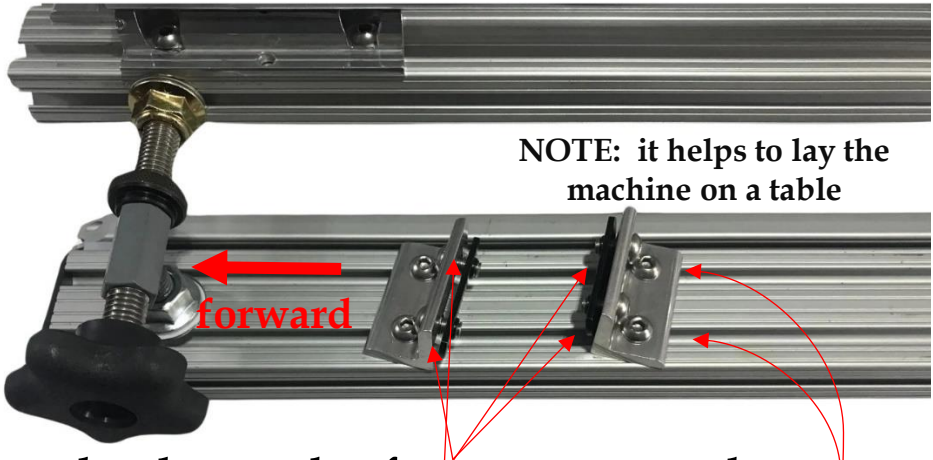

back out the four screws to leave  
enough play to slide in leg. Also loosen  
the right-side/inside bracket.  
Slide the leg in place and tighten all the  
screws. Do the same thing with your  
rear leg and stand up.



Slide the release carrier block in place.

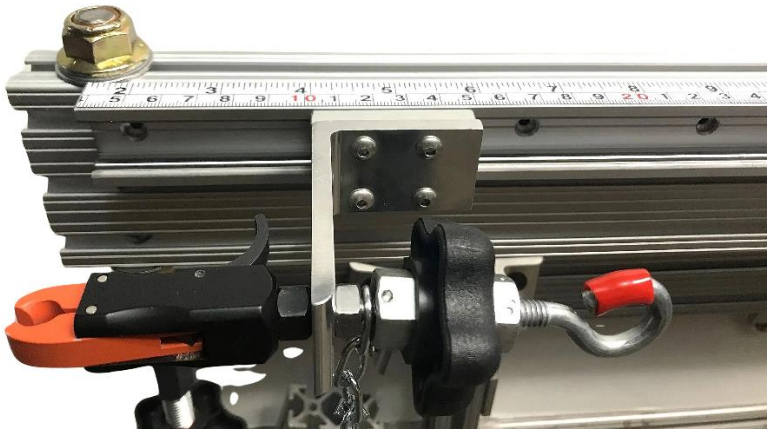

Connect the strap and slide the red grommet in place, this holds the strap from coming off.

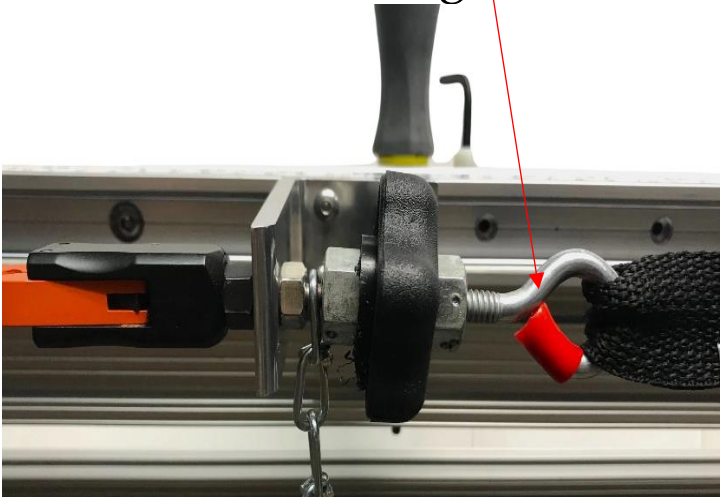

If not already installed

Slide the 1- inch by 2-inch tool carrier in place on the backside.

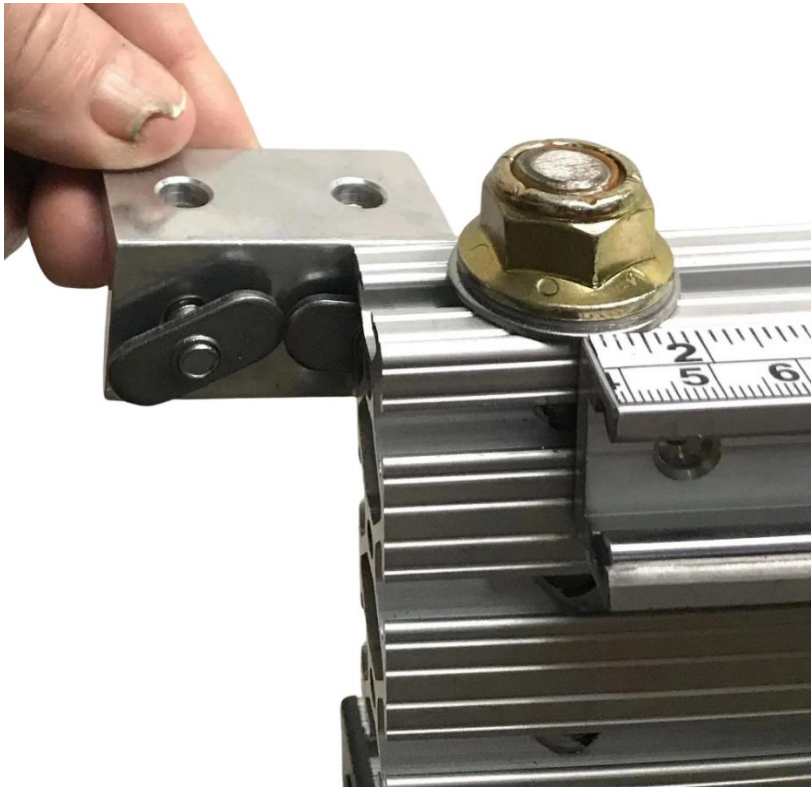

If not already installed-Slide the forward assembly in place and tighten.

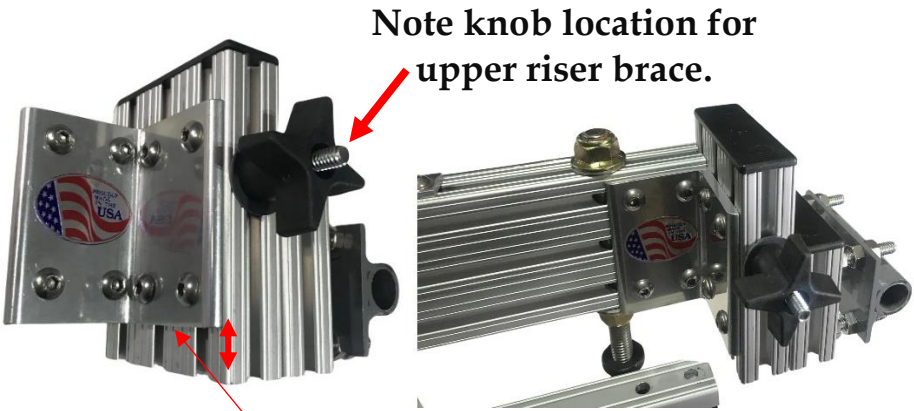

NOTE: this is preset but it's just a starting point

NOTE: yellow stop is preset but it's just a starting point

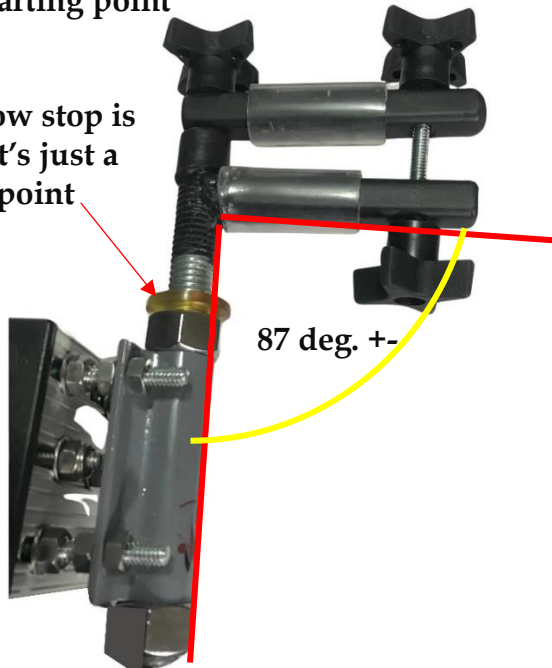

Install bow hand as seen in pics.

# Installing the paper tuner



Slide the 9 inch by  $\frac{1}{2}$  inch bottom part onto the 1 by 1 bar and tighten the  $\frac{1}{4}$ -20 nut through the bottom hole. Locate the paper tuner brace and install.





Slid the bottom first over bolt then slide upper piece into guide.



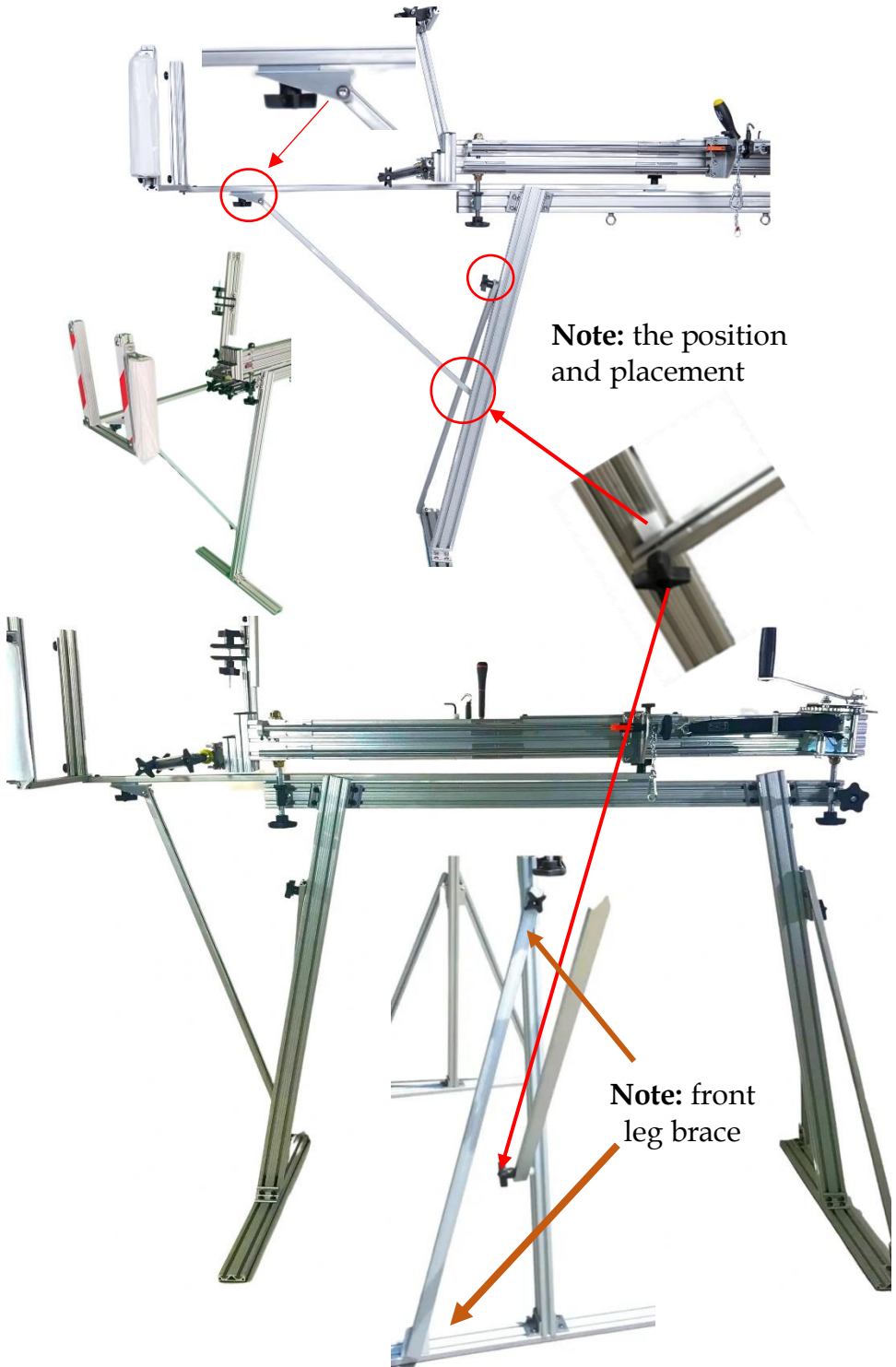

**Note: the position and placement**

**Note: front leg brace**





Install the 2-hole bracket into the slide. The protrusions should face up. Short bolt goes in first loosely then the long bolt. Tighten the short bolt, remove the long bolt, and use it to attach the paper holder to the slide rail.



**Fold the paper holder to the side when retracting or extending to avoid binding.**



It should look like this when done.



# Setting up a bow in the Bowsmith

Your Bowsmith comes pre-assembled and pre-tuned for a Hoyt Pro Comp Elite.

(These settings should work for most compound bows)

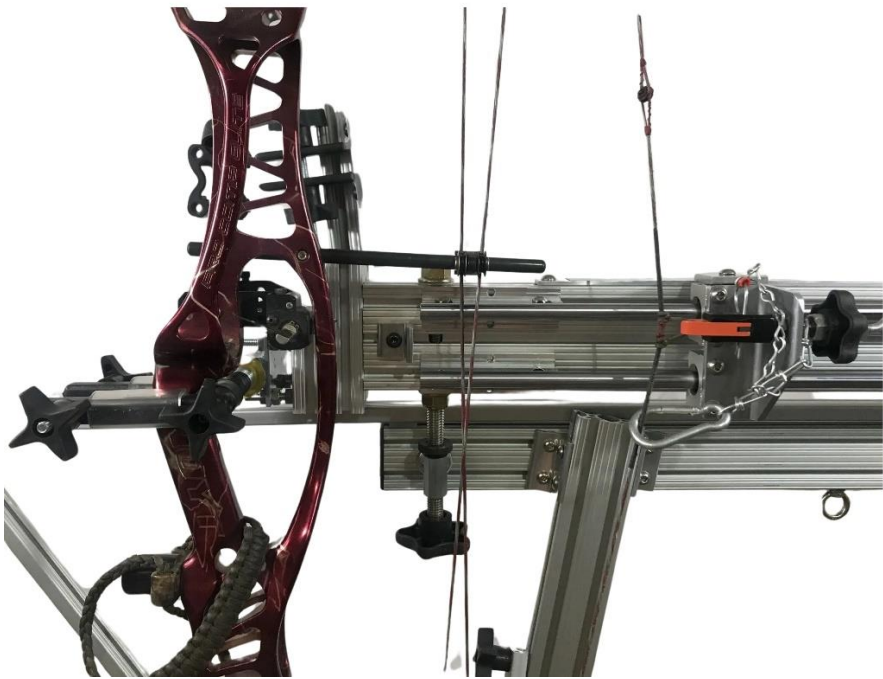

Set your bow in the bow hand. **Put both safeties on** and winch it a couple clicks.

This sets the grip against the post.  
Tighten the bow hand alternating from rear first to front.

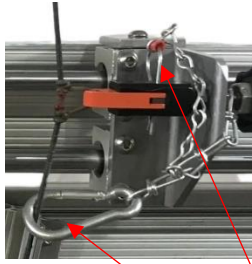

**NOTE: always  
use both  
safeties**

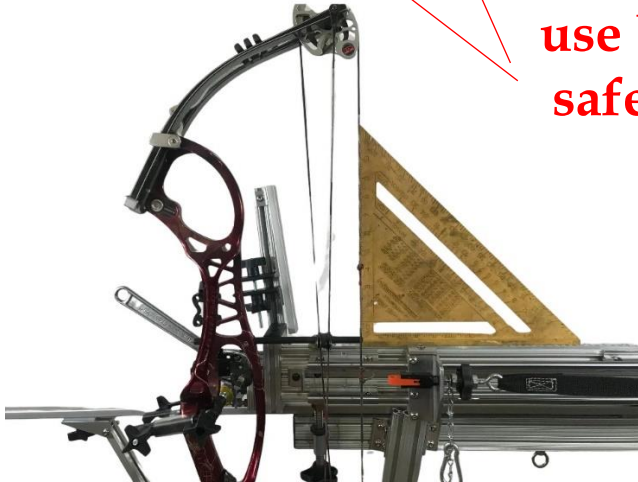

square the bow to the top rail. Using a  
crescent wrench tighten the 5/8 nut on the  
bow hand.

**Close counts**

**Don't over tighten snug is fine.**

**Tighten the rear knob first**

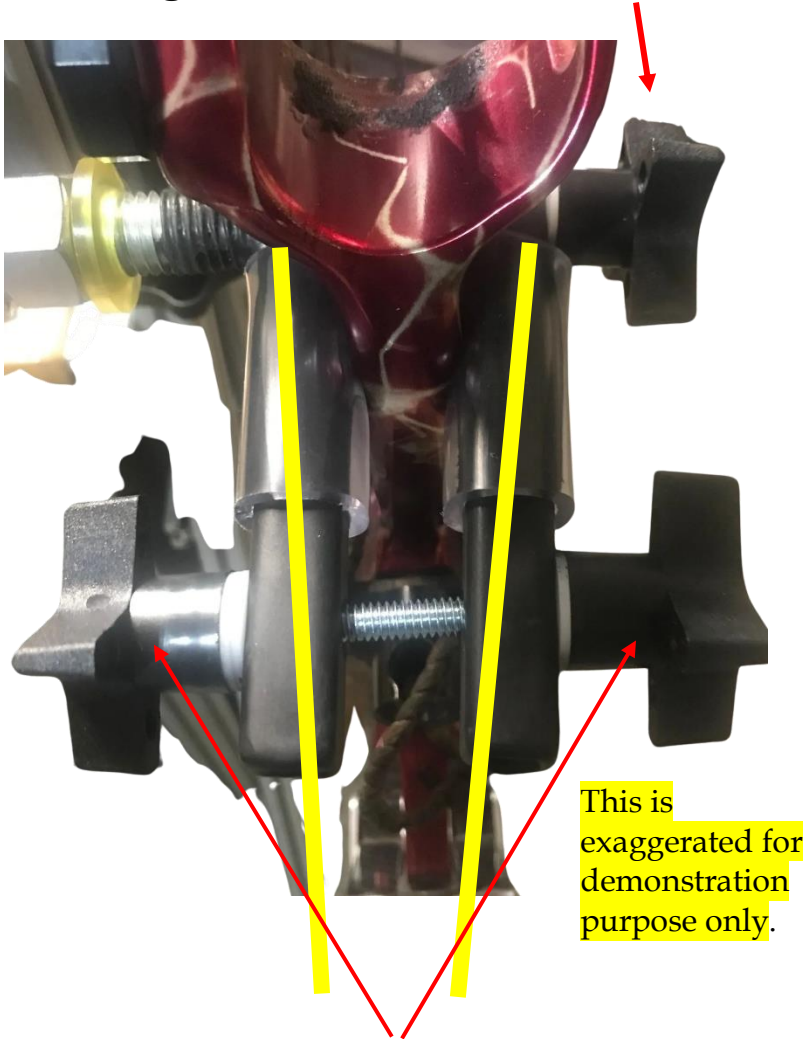

This is exaggerated for demonstration purpose only.

**Then tighten the front knobs so they pinch the front of the bow holding the bow tight to the post. The squish tubes will conform to the bow helping to keep the bow positioned**

**Your release should align like this**

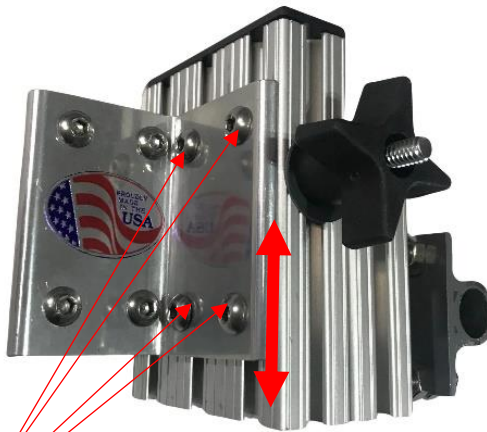
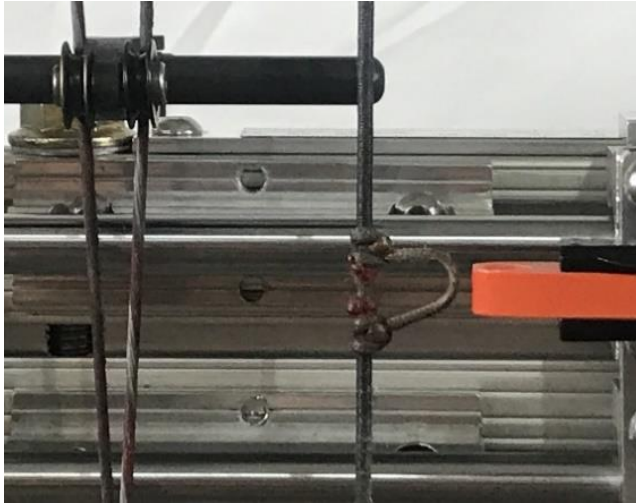

**Your release should align like this if not, loosen the 4 screws and slide the 5 inch by 3 inch block up or down.**

To set the draw gauge install your bow plumb level and square. Attach the d-loop and take out all the play.

Loosen the 3 retaining screws and slide the rail until your known brace height aligns with the edge of the carrier block and re-tighten the screws. The bow in the pic has an 8.5 inch brace. Once aligned this will give you accurate readings at full draw.

3 screws  
snug only

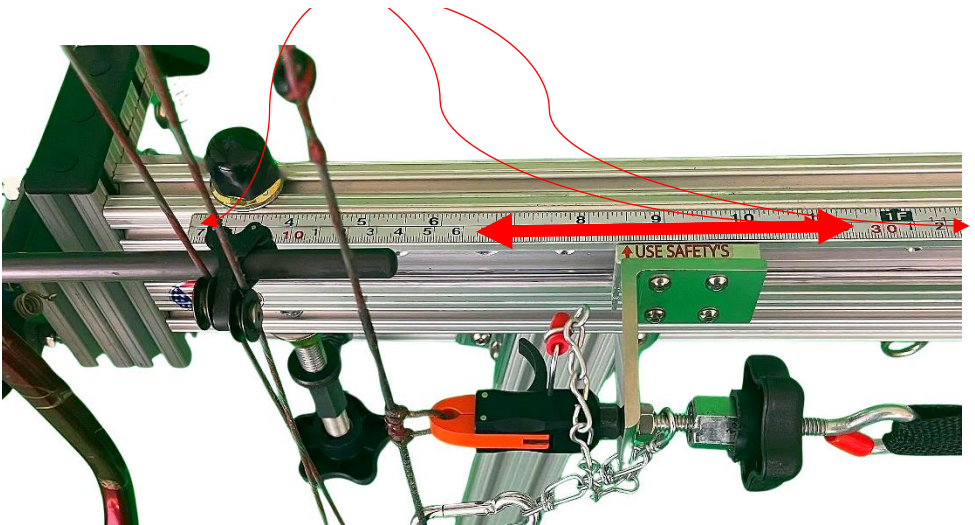

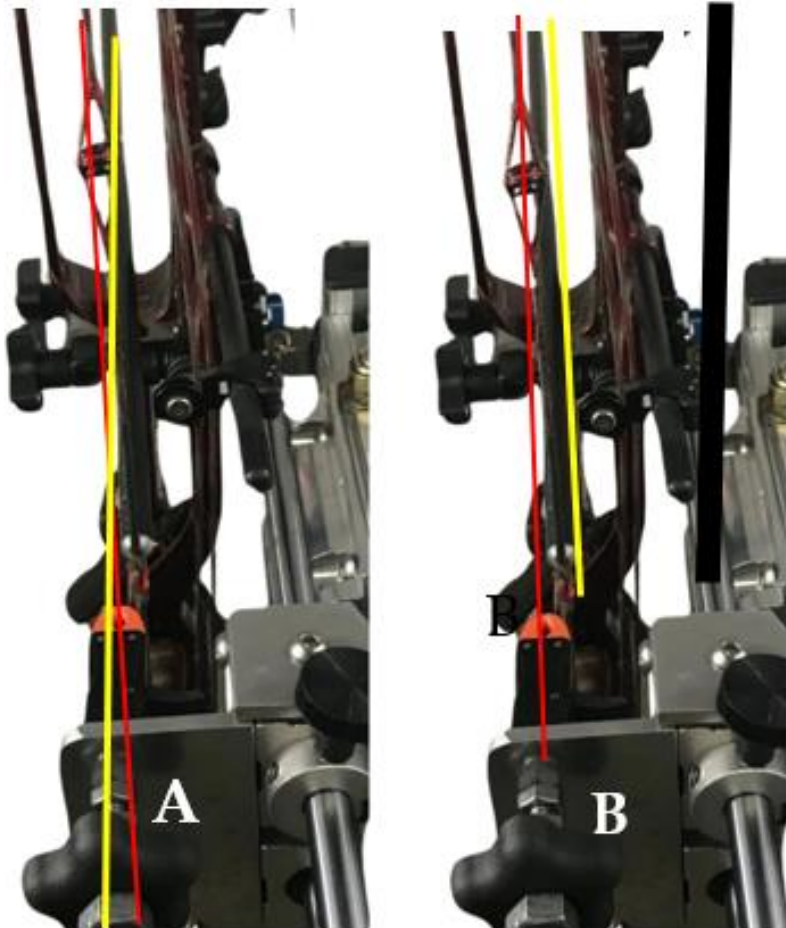

*with a arrow in the bow-* Sight down the back of the machine you may see one or a combination of a offset shaft or a crooked shaft . In **(A)** the shaft and bow are not square to the machine. A is corected by adjusting the torque box  $\frac{1}{4}$ -20 nuts. **(NOTE: a light snug is all that's needed on the  $\frac{1}{4}$  -20 nuts.)**



to correct ( A ) move the nuts in or out to change the angle of the bow. A little goes a long way. If it requires a lot try reajusting the bow in the grip.

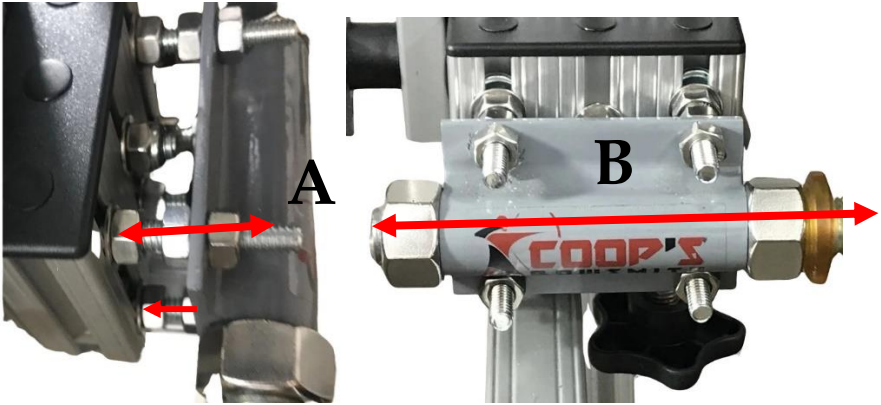

In B we adjust the bow hand in or out.

NOTE: any time you preform either procedure you must remove the upper limb brace.

**Remember to keep away from the front of the machine, never stand in front of the machine. Keep your hands and fingers out of the way. Keep your kids away. Check for loose bolts and always pay attention to what you are doing.**

## Plumbing the bow from left to right



To plumb the bow loosen the for screws and rotate the box left or right



Adjust guide to keep the strap parallel to the rail.

When correct it will sight straight.  
NOTE: this does not need to be perfect  
but the closer the better

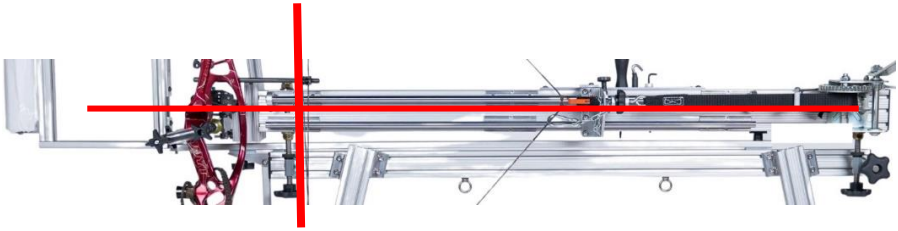

**With everything close now you can install  
the upper limb brace**

If you have not pre-  
installed the knob, pin,  
and washer you **may**  
have to loosen the bow  
holder assembly to  
install in the side slot.



Stows folded  
in place until  
ready to use.





Find a spot on the riser. Preferably a flat spot and lock the brace in place without moving the bow.

NOTE: even with the brace installed the bow will move slightly when shot. A couple shots and it will settle in.

It may help to lower the bow a  $\frac{1}{4}$  inch using the 5 inch block if it keeps moving.

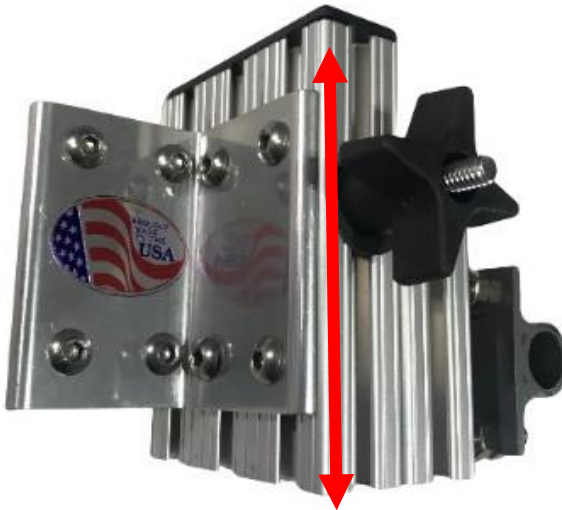
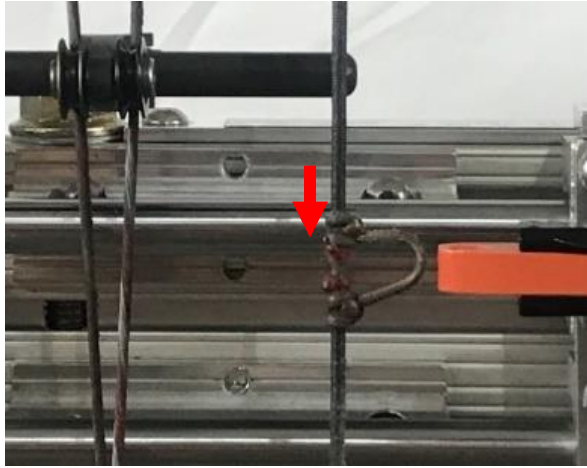

# Shooting a arrow

Before shooting go back and tighten the feet and leg bolts with the L wrehch.

**They must be tight or they will move**

Sand bag the feet or hang water buckets from the eye hooks

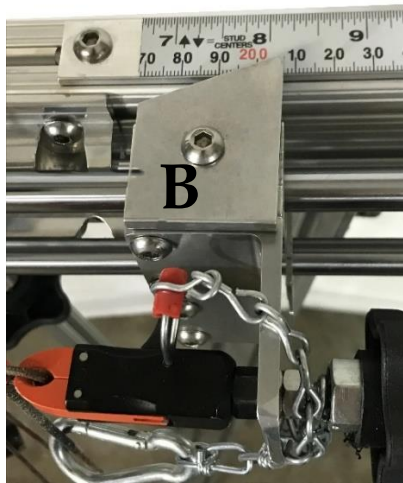

Slide your release forward close the jaws and install both safty devises. (A)

If you know your bows brace high set the scale to match in this case its 8.25.( B )

Crank the bow back smoothly to just short of full draw. Fine adjust with the micro adjustment (A).

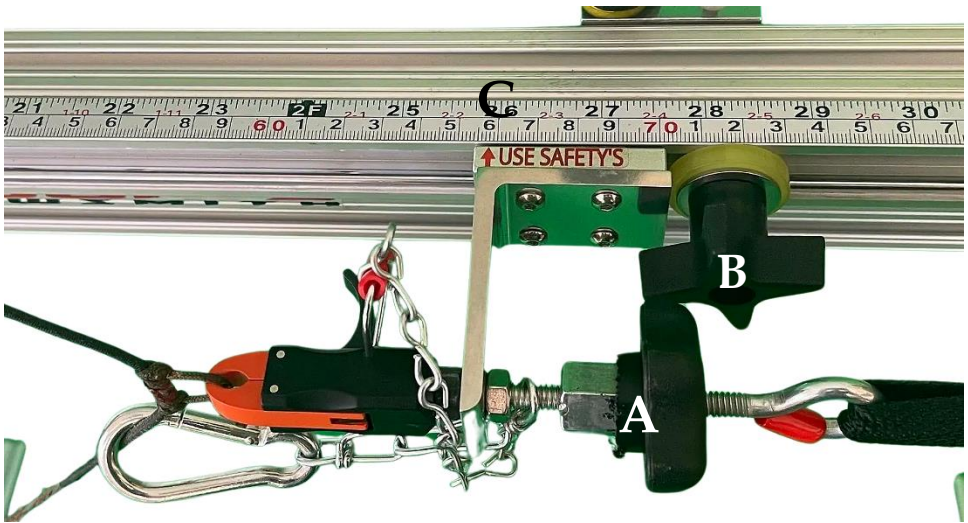

Set the draw stop in place (B).

Draw length is now displayed (C) Remove the string catch first, pull the pin and its ready to fire. Make sure of your target! No one in front! No body parts in or around the bow! Pull trigger to fire.

Use the draw scale On successive shots to relocate the exact draw point. Dont rely on the drawstop its just a saftey devise to prevent overdrawing your bow

## **Tuning Arrows with the Bowsmith Pro**

Tuning arrows is a learning process. Fire a few arrows to settle the machine in. Don't move the bow after you shoot. You should be able to slide the release into place without touching the bow. The release should line up with the D loop every time. Your bow sight should stay level or close and your string should stay plumb or close. I tune fully fletched arrows only. Shoot 12 arrows and find the ones that hit the same hole, set these aside and tune the rest of the fletched arrows. Turn the nocks from the cock vane to the next vane and find the one that shoots closest to center. Most guys who tune this way keep all their vanes the same color and mark the cock vane with a marker. Pay attention that nothing moves. I use one good arrow to double check things as I go.



A very accurate way to shoot after you have set the machine up and test fired a shot or two is to leave the winch clicker off. Crank the bow back to full draw with your right hand, just short of the overdraw stop using the pointer to get the exact same draw length, hold the winch handle and pull the release with your left hand.

**Remember to keep away from the front of the machine, never stand in front of the machine. Keep your hands and fingers out of the way. Keep your kids away. Check for loose bolts and always pay attention to what you are doing.**

# using a draw scale

we strongly recommend using the **Last Chance Bow Scale 3.0**.



Note : if bought through us it comes with the needed draw board hook.



Never use the release on the machine!  
Catastrophic damage can result.

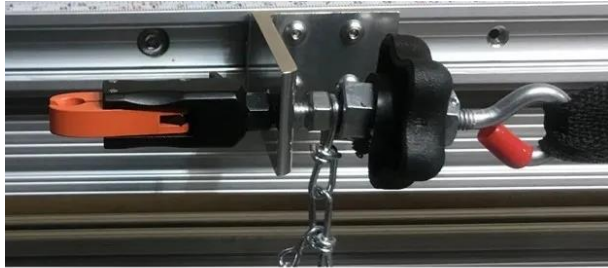

**swap the release for the included draw board hook**

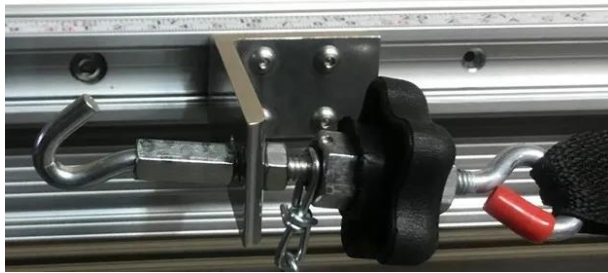

**Hook to string only . Do not trust d-loop alone**

**Follow directions that come with scale**

# Paper Tuning

Paper tuning is straight forward. I will be using the Bowsmith pro with its attached paper holder.

Slide the paper holder from its stowed position and lock it into place. Then rotate the paper frame into its shooting position. Note: trying to slide this in or out without the paper frame in its stowed position **will cause binding**.

Make sure your arrow is aimed at the backstop and shoot an arrow through the paper. As you can see in figure 81, we have a perfect bullet hole. If the bow is set up correctly you should get this on almost any new set up. If you have a rip or offset hole, follow the diagram on figure 82 to correct.

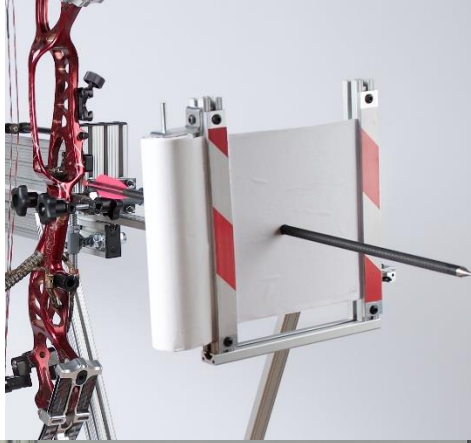

Figure 80



Figure 81

Do not waste your time shooting bare shafts thru paper! Without fletching, the back of the shaft tends to follow the hole the point made.

rip =nock high, point low  
\*move nocking point down



rip =nock low, point high  
\*move nocking point up



rip =nock left, point right  
\*move rest to the right  
\*yoke tune or timing problem  
\*spine too weak

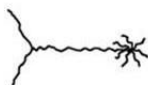

rip =nock right, point left  
\*move rest to the left  
\*yoke tune or timing problem  
\*spine too stiff



IF YOU HAVE A COMBINATION OF THE ABOVE RIPS, CORRECT VERTICAL TEAR FIRST THEN MOVE TO THE HORIZONTAL CORRETION....

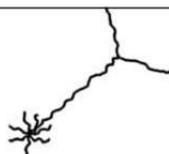

UNTIL YOU ACHIEVE.. **PERFECT!!**



Figure 82

# Chronograph

To use your chronograph, remove the paper holder and install the holder as shown in the picture. Bracket is stowed on the side of the paper holder. The flat bar should be installed from the bottom.



Make sure your arrow is above the chronograph.



Slide the holder all the way out and lock it in place.

DO NOT lift the chronograph as you tighten the knobs as this could raise it to a dangerous level. It should look like the picture.

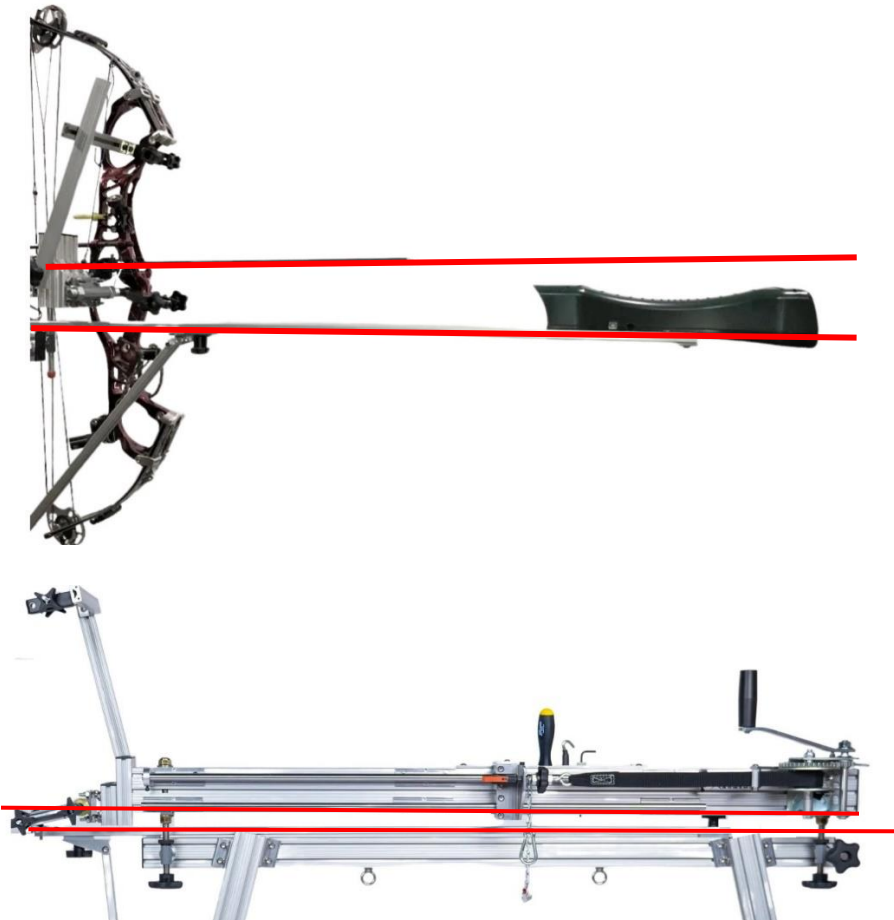

Your machine should look like this both rails parallel.



**Do not do this.**

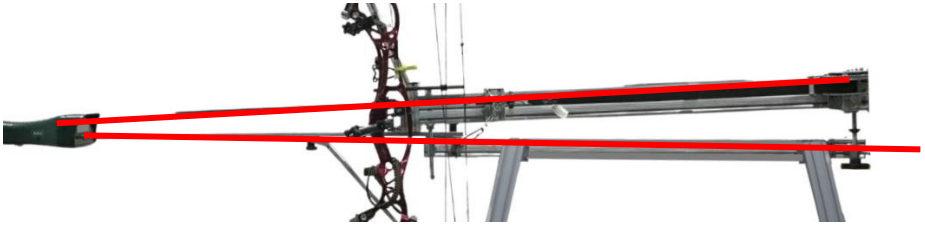

**Do not adjust the back of your bow up  
as seen in picture above.**

**You will shoot your chronograph!**  
Follow your chronographs directions  
and you should get excellent results.

**Another useful tool is a Bowmaster cable press or our custom-made limb retainers.**

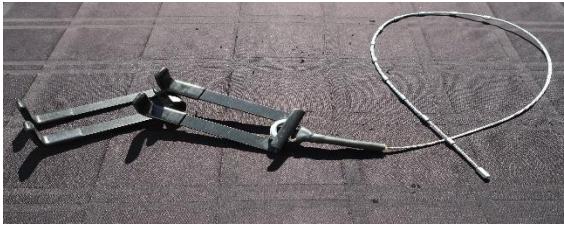

You only need a couple of inches of a draw to apply.

**Do not use at full draw!**

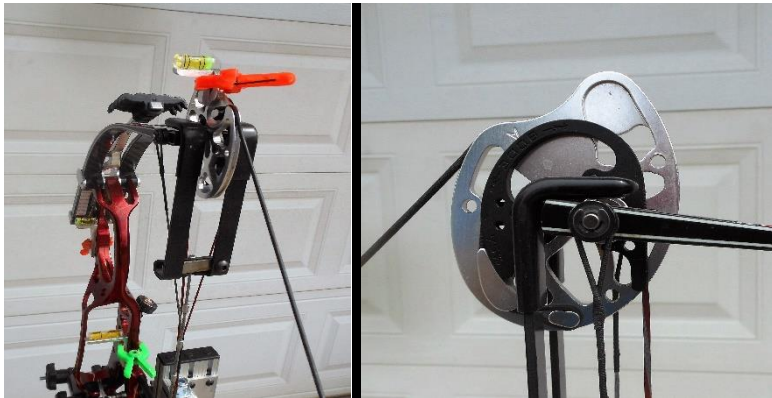

**These retainers were designed to be used with the Bowsmith Pro but work well on any Draw Board. Extreme caution must always be used! Never put your face near the cams or put your fingers in the cams while the clamps are on.**

**Do not use bows with extreme curl like the Bear Carnage.**

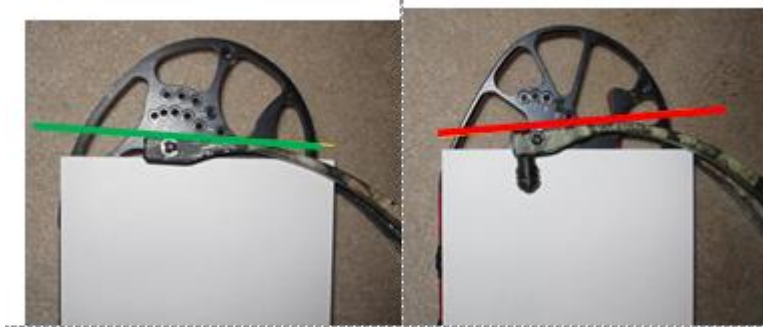

**Almost parallel + 1 degree** **Past-parallel -6 degrees**  
Almost Parallel versus Past Parallel

The Bow Master L clamps can possibly slip off when used on past parallel limbs greater than 6 degrees. Use caution whenever using the Bow Master L clamps on any bow.

Draw your bow just enough to fit the Bow Master L Brackets onto your bow. Set the L brackets in place and adjust the cable for the proper fit.



Scan QR code with your  
phones camera to access  
video.



Scan for store for all  
options

I'm always interested in hearing from  
users who have found new ways to use  
our machine. Please drop me a line at

[coopsbowsmith@gmail.com](mailto:coopsbowsmith@gmail.com)

Good shooting, Coop

(815)-325 -9128

OWNER \_\_\_\_\_

MAKE AND MODEL \_\_\_\_\_

FACTORY SETTINGS

ACTUAL BEFORE TUNE

AXEL TO AXEL \_\_\_\_\_

BRACE HEIGHT \_\_\_\_\_

DRAW LENGTH \_\_\_\_\_

DRAW WEIGHT \_\_\_\_\_

LIMB BOLT SETTING \_\_\_\_\_

PEEP HEIGHT \_\_\_\_\_

SIGHT RADIUS \_\_\_\_\_

---

TUNED SETTINGS

AXEL TO AXEL \_\_\_\_\_

BRACE HEIGHT \_\_\_\_\_

DRAW LENGTH \_\_\_\_\_

D- LOOP \_\_\_\_\_

DRAW WEIGHT \_\_\_\_\_

LIMB BOLT -TOP \_\_\_\_\_

BOTTOM \_\_\_\_\_

PEEP HEIGHT \_\_\_\_\_

SIGHT RADIUS \_\_\_\_\_

TILLER + - BOLT TURN TOP \_\_\_\_\_

BOTTOM \_\_\_\_\_

ARROW Shaft \_\_\_\_\_

WEIGHT \_\_\_\_\_

SPEED/ CHRONOGRAPH \_\_\_\_\_

OWNER Vern Coop

MAKE AND MODEL 2014 Hoyt pro comp, gtx-2, 75%

FACTORY SETTINGS

ACTUAL BEFORE TUNE

AXEL TO AXEL 36-15/16

37-1/8

BRACE HEIGHT 7-15/16

8

DRAW LENGTH -26.25

25.75 D-loop- 26.25

DRAW WEIGHT 40-50

47

LIMB BOLT /TILLER

top 2.25 bottom 1.75

PEEP HEIGHT

static 5-7/16 full draw

4

---

TUNED SETTINGS

AXEL TO AXEL 37

BRACE HEIGHT 8

DRAW LENGTH 25.75

D- LOOP 26-

1/8th

DRAW WEIGHT 47

LIMB BOLT -TOP 2

BOTTOM 2

PEEP HEIGHT 5-7/16

SIGHT RADIUS 32.125

TILLER + - BOLT TURN TOP 0

BOTTOM 0

ARROW Shaft \_\_\_\_\_

WEIGHT \_\_\_\_\_

SPEED/ CHRONOGRAPH \_\_\_\_\_

Now with your bow shooting good from the machine, it's time for you to shoot the bow. Concentrate on trying to use your best form. If you have good form your shots should duplicate that of the machine. And you should be shooting bullet holes. If you are getting major tears, contact a coach and have him check your form and adjust if needed.

For small imperfections, about the diameter of your shaft, no adjustment is needed as it is common for your form to move around a touch until you become as good as your favorite pro.

I am a good shot, and it is typical for me to have a slight left tear one day and a slight right a few days later. It's important that you know your bow is correct!

Remember we all have good and bad days. Don't start tweaking your bow because you're having a bad day.

