



Hydraflo™ HNC

HNC - Hydraulic High Volume Submersible Pump and 3000D Drive Unit

APPLICATIONS:

Flood Control

Industrial

Bypass Pumping

Stormwater Drainage

Construction Dewatering

Agriculture

Aquaculture

Quarries

The MWI Hydraflo™ hydraulic submersible pumps coupled with their diesel or electric drive units are an unbeatable combination for: drying out construction excavations, quarry dewatering, bypassing sewage, general municipal use and industrial work. These units are designed and manufactured for the toughest environments with the best combination of ruggedness, reliability, performance, operational costs and initial price. Hydraflos never quit – positively affecting your success and bottom line.

FEATURES

3000D Diesel Engine Drive Unit

- Skid mounted unit - Standard
 - Trailer mounted unit available - With optional fenders, DOT light kit and braking system
- Engine and hydraulic safety shutdowns
- Complete Hydraulic System with control panel, pump, filters, tank and gauges
- Small hydraulic tank reduces fluid replacement costs
- Reliable, efficient Vane Hydraulic Pump
- Environmentally friendly - inherently biodegradable hydraulic fluid
- Auto Start Stop Panel available with floats

Hydraflo™ - HNC

- High performance
 - 20,000 GPM
 - 65 Ft. TDH
- Closed 2 bladed impeller for handling trash and sewage
- Easily passes 6" spherical solids
- Runs dry indefinitely
 - Oil lubricated seals and bearings
- Reliable, rugged Vane/Piston Hydraulic Motor
- 200% Larger Solids Handling Capability
- 50% smaller footprint required (less space required)
- Up to 40% less energy consumed*



*as compared against standard skid mounted end suction centrifugal pumps operating at maximum lift

PERFORMANCE

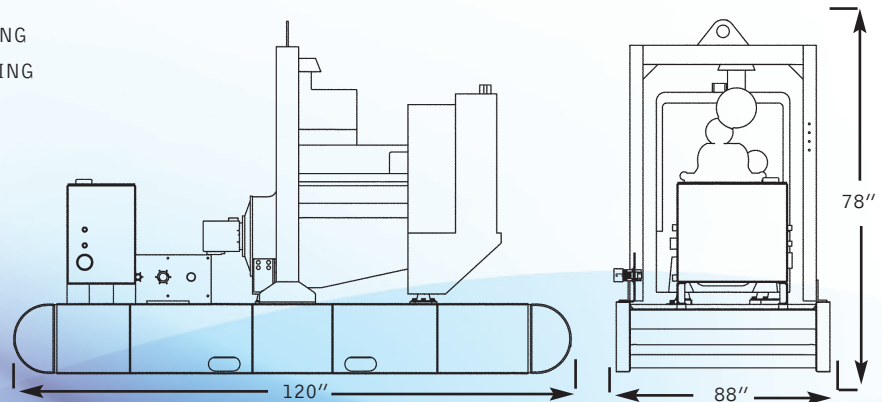
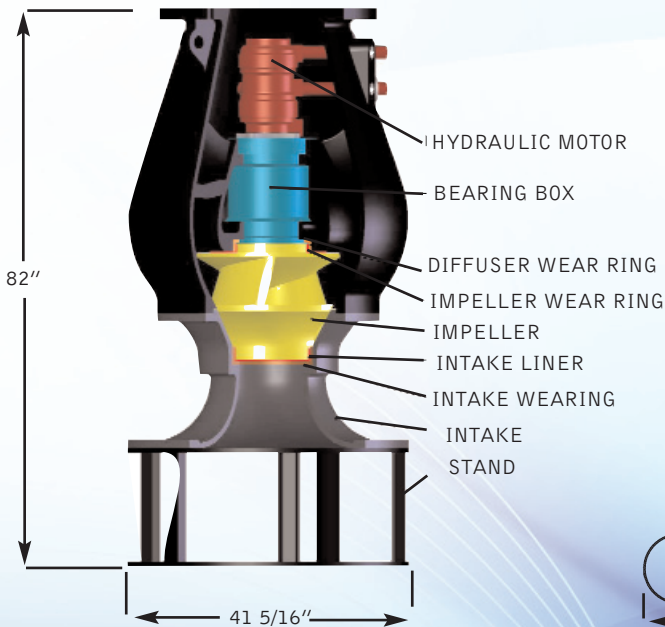
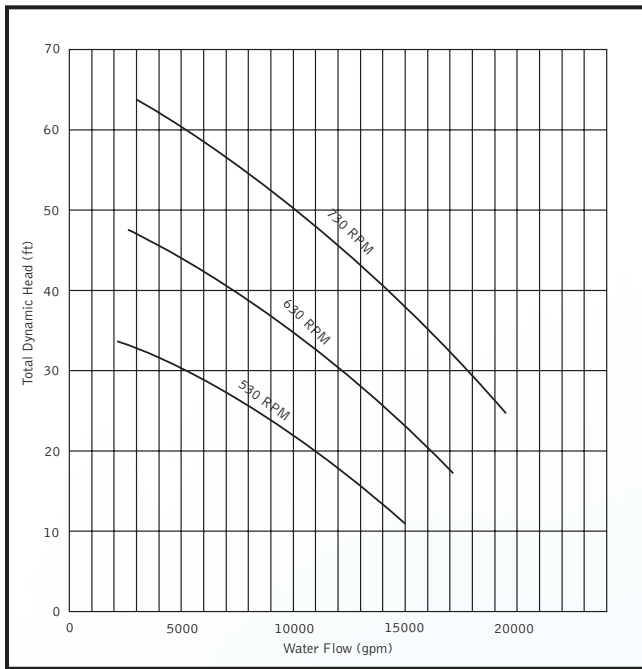

MATERIALS & SPECIFICATIONS

HNC

- Hydraulic Motor - Vane or Piston type
- Impeller - Closed 2 bladed cast iron
- Shaft material - 300 series stainless steel
- Volute - Cast iron
- Discharge - 20" ANSI
- Hydraulic quick disconnects - 2" Supply, 1 1/2" Return, 3/4" Case Drain
- Mechanical seal - Silicone carbide - Hydraulic-fluid bathed
- Bearings - Hydraulic-fluid lubricated - 50,000 hours - Minimum life.
- Weight - 4500 lbs
- Coating - MoTar Standard - Epoxy optional

3000 Drive Unit

- Diesel engine - 300 HP at 1800 RPM
- Engine panel with tach, hour meter, high coolant temperature and low oil pressure shutdowns plus over speed protection.
- 100 gallon vented fuel tank with extra large filler and fuel gauge.
- 60 gallon hydraulic fluid tank
- Safety shutdowns for low hydraulic oil, excessive vacuum and high hydraulic oil temperature.
- Equipped with an internal suction strainer, return filter, external sight gauge for hydraulic oil and vented hydraulic oil filler cap.
- Hydraulic pump - Densison Vane type
- Weight: 9800 lbs (dry)



MWI Corp. Hydralo is a registered trademark. Copyright 2011. All rights reserved. Designs and specifications may change due to continual improvement of our products. P0211

Moving Water Worldwide - Reliably and Efficiently

201 N. Federal Highway Deerfield Beach, Florida 33441 USA
Phone: (954) 426-1500 Fax: (954) 426-1582 E-mail: info@mwicorp.com www.mwipumps.com