

SLIDE RAIL COUPLING SRC-1½

To be used with
2 HP grinder pumps.



LOCATION

This SRC-1½ is designed for wet wells, tanks, or lift stations where it is necessary to remove a pump from service and reinstall the pump without maintenance personnel entering the pit to unbolt the pump flanges.

FEATURES

- ▶ 1½" NPT pump connection.
- ▶ 2" NPT vertical discharge.
- ▶ ¾" or 1" stainless steel guide rails
(provided by installer).
- ▶ Stress-free rail system.
- ▶ Durable cast iron base and lift-out flange.
- ▶ Stainless steel pump adapter and guide plate.

STATIONARY ELBOW

Cast iron ASTM A-48 class 30.

MOVABLE FITTING

Ductile iron ASTM A-536.

GUIDE RAIL CAP

Bracket: 304 stainless steel.

Plugs: ductile iron ASTM A-536-84.

HARDWARE

304 series stainless steel.

O-RINGS

Buna-N, 70 ±5 Duro.

GASKETS

Rubber.

PAINT

Air dry enamel, water based.

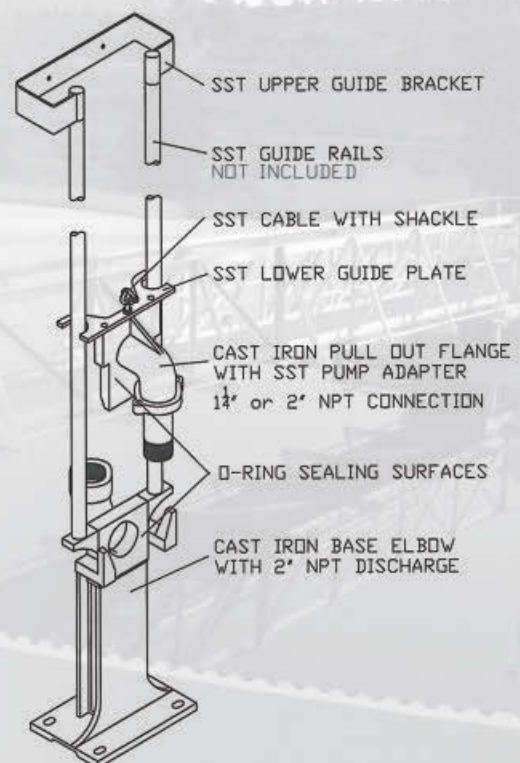

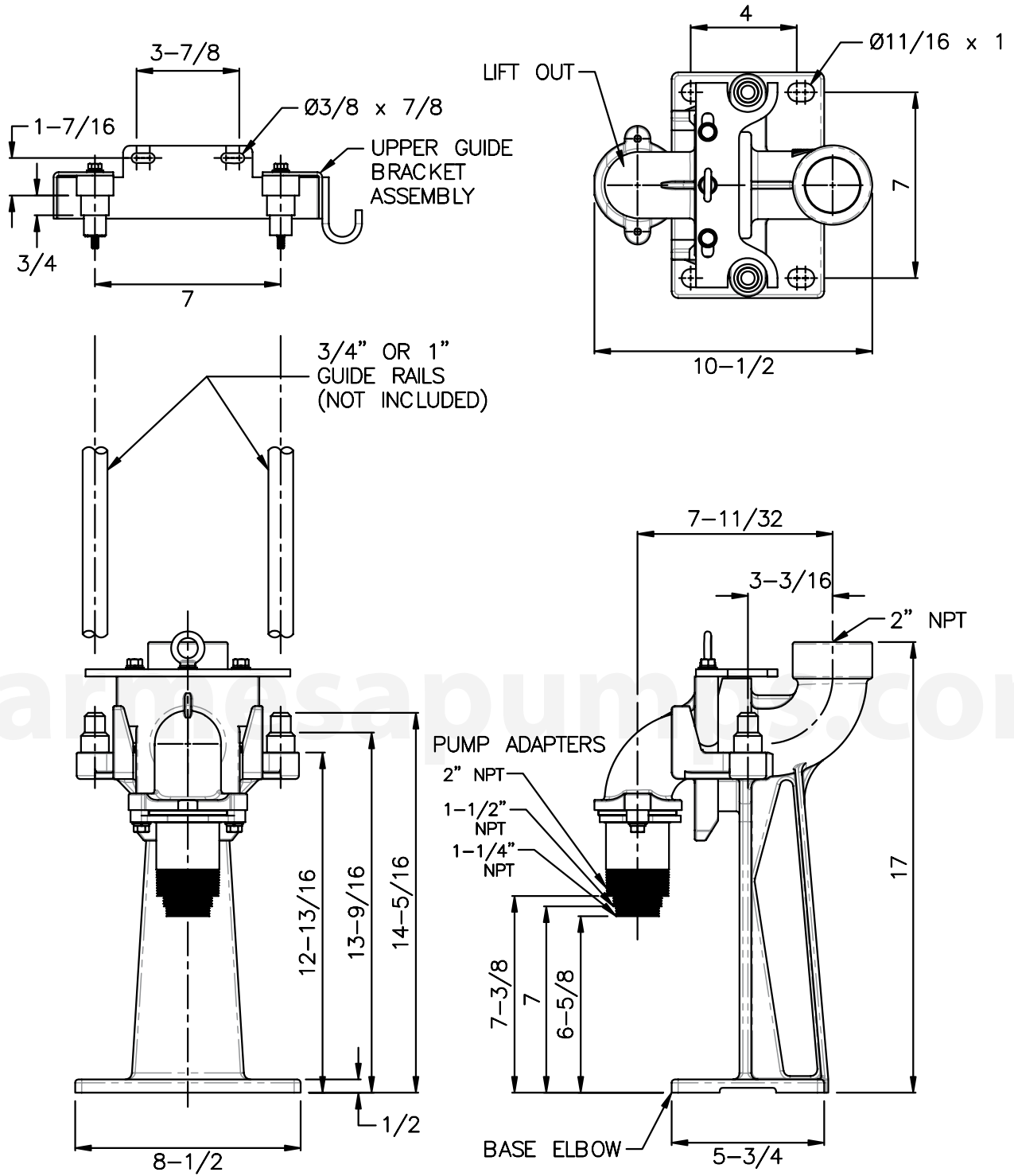

MODEL	PART No.	SIZE	RAILS	COUPLING	WEIGHT (pounds)
SRC150	62170804	1¼"	3/4" or 1"	w/ upper guide bracket	45