

SLIDE RAIL COUPLING SRC-6

To be used with
6BSE series pumps.



LOCATION

This SRC-6 is designed for wet wells, tanks, or lift stations where it is necessary to remove a pump from service and reinstall the pump without maintenance personnel entering the pit to unbolt the pump flanges.

STATIONARY ELBOW

Cast iron ASTM A-48 class 30.

MOVABLE FITTING

Ductile iron ASTM A-536.

GUIDE RAIL CAP

Bracket: 304 stainless steel.

Plugs: ductile iron ASTM A-536-84.

HARDWARE

304 series stainless steel.

O-RINGS

Buna-N, 70 ±5 Duro.

GASKETS

Rubber.

PAINT

Air dry enamel, water based.

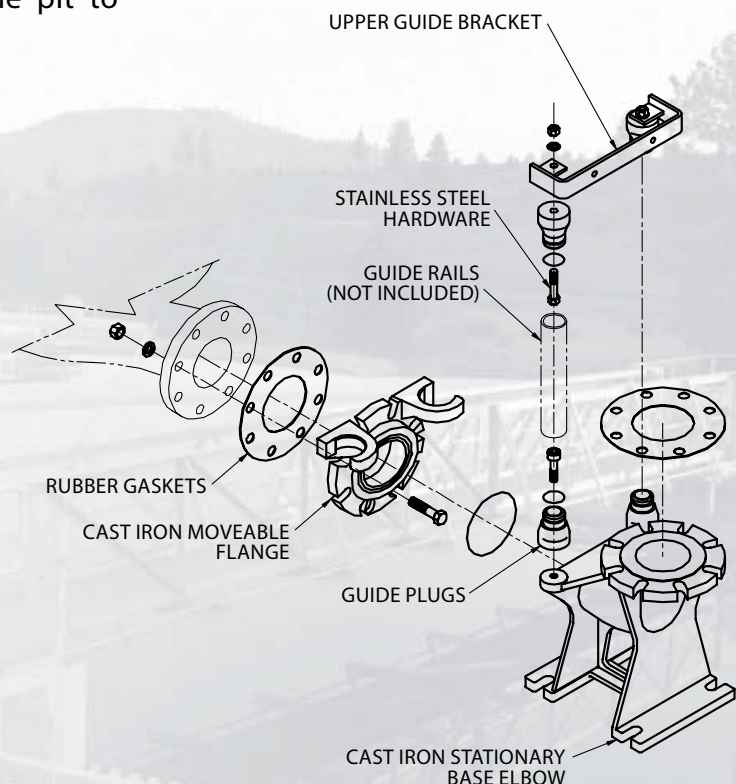

inches
(mm)

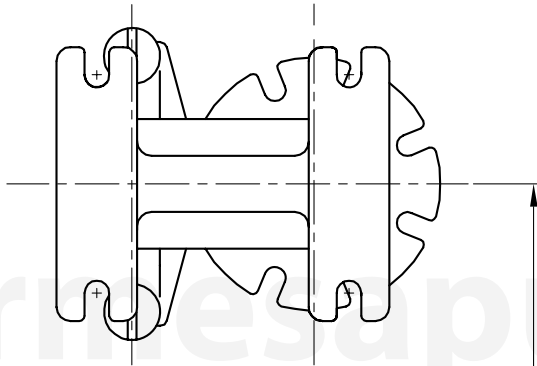
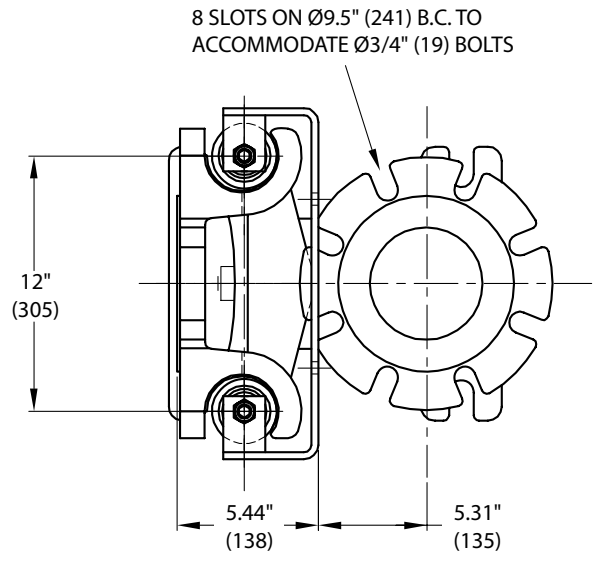
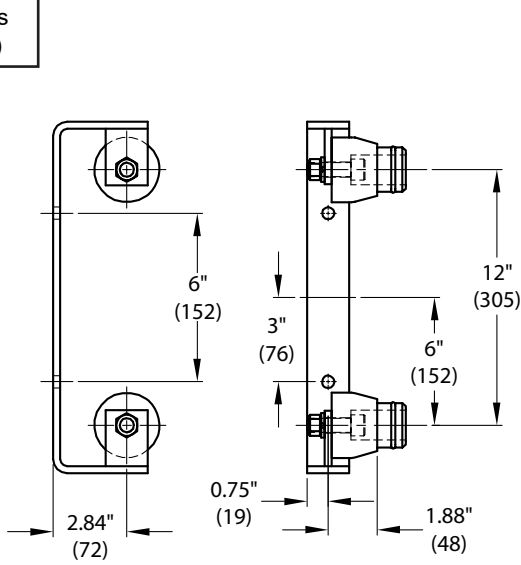

DUPLEX = 26" (660) TO 32.25" (819)

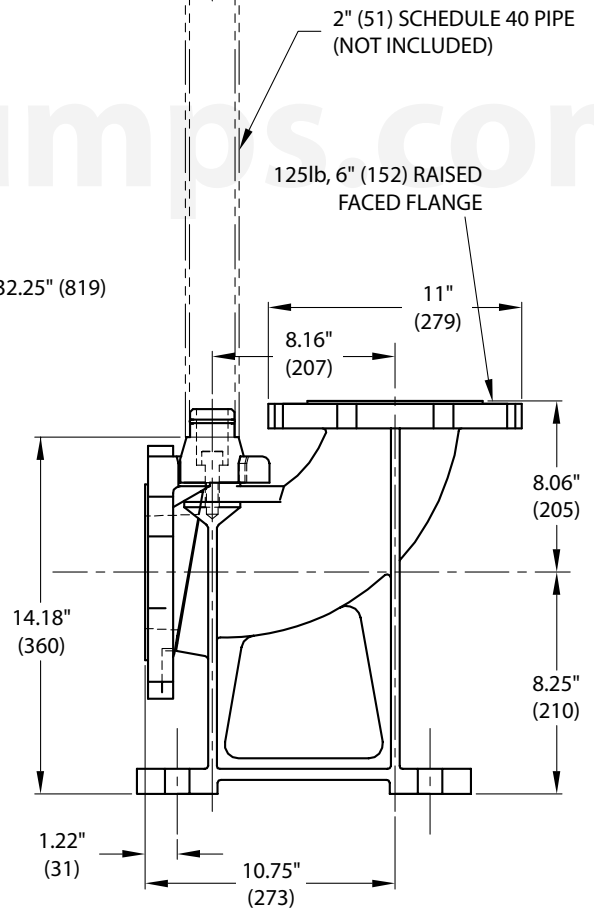
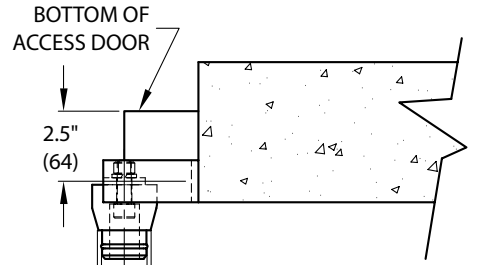
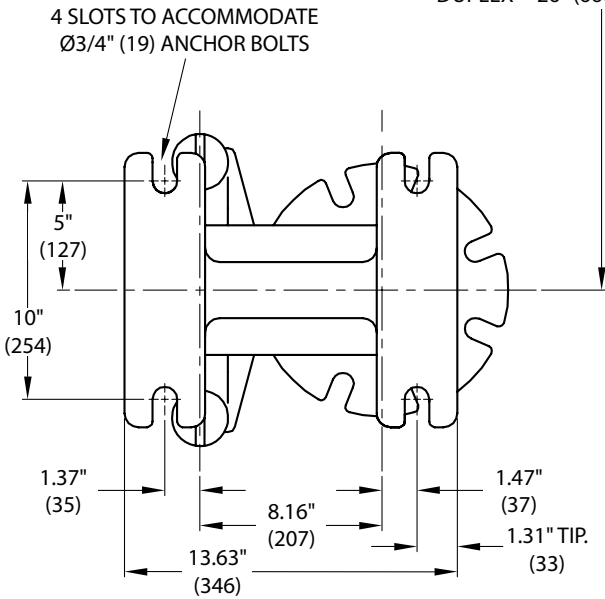

MODEL	PART No.	SIZE	RAILS	COUPLING	WEIGHT (pounds)
SRC6	62170802	6"	2"	w/ upper guide bracket	180
SRC6-FA	62170816	6"	-	flygt adapter	42