

SLIDE RAIL COUPLING SRCH-2

To be used with
BGPH series pumps.



LOCATION

This SRCH-2 is designed for wet wells, tanks, or lift stations where it is necessary to remove a pump from service and reinstall the pump without maintenance personnel entering the pit to unbolt the pump flanges.

FEATURES

- ▶ 2" flange, horizontal pump connection.
- ▶ 2" NPT vertical discharge.
- ▶ 1¼" stainless steel guide rails (provided by installer).
- ▶ Stress-free rail system.
- ▶ Durable cast iron base and lift-out flange.
- ▶ Stainless steel pump adapter and guide plate.

STATIONARY ELBOW

Cast iron ASTM A-48 class 30.

MOVABLE FITTING

Ductile iron ASTM A-536.

GUIDE RAIL CAP

Bracket: 304 stainless steel.

Plugs: ductile iron ASTM A-536-84.

HARDWARE

304 series stainless steel.

O-RINGS

Buna-N, 70 ±5 Duro.

PAINT

Air dry enamel, water based.

inch [mm]

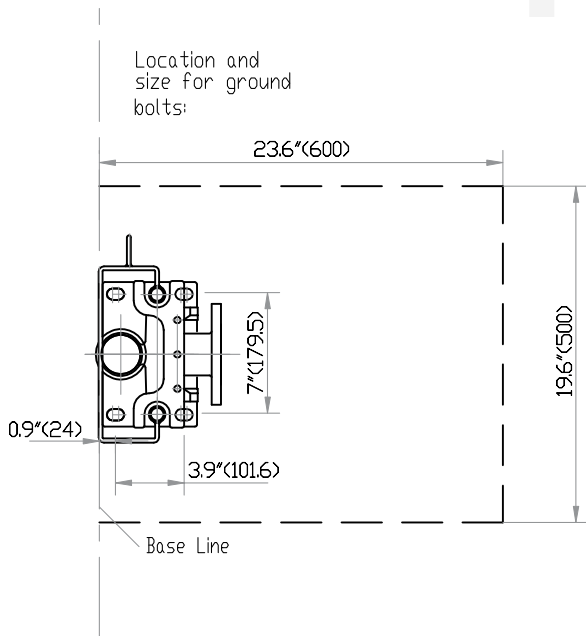
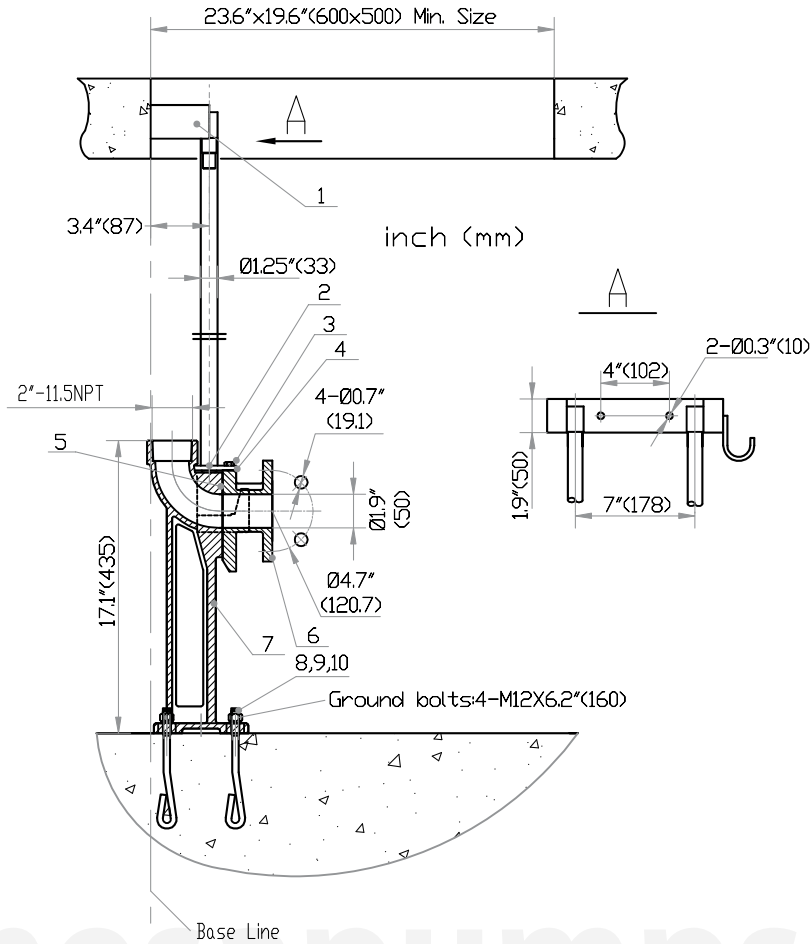

ITEM	QTY.	DESCRIPTION	MATERIAL
1	1	UPPER GUIDE BRACKET	SST
2	2	DOWEL PIN	SST
3	3	SCREW HXHD M8 x 16	SST
4	1	LOWER GUIDE PLATE	SST
5	1	O-RING	BUNA
6	1	PULL OUT FLANGE	IRON
7	1	BASE ELBOW	IRON
8	4	NUT M16	SST
9	4	WASHER LOCK 16	SST
10	4	ANCHOR BOLT M16 x 220	SST

MODEL	PART No.	SIZE	RAILS	COUPLING	WEIGHT (pounds)
SRCH200	-	2"	1 1/4"	w/ upper guide bracket	46.3

SPECIFICATIONS

barmesapumps.com