

# SLIDE RAIL COUPLING SRCH-3

To be used with  
3BWSE-DS series pumps.



## LOCATION

This SRCH-3 is designed for wet wells, tanks, or lift stations where it is necessary to remove a pump from service and reinstall the pump without maintenance personnel entering the pit to unbolt the pump flanges.

## FEATURES

- ▶ 3" flange, horizontal pump connection.
- ▶ 3" NPT vertical discharge.
- ▶ 1" stainless steel guide rails (provided by installer).
- ▶ Stress-free rail system.
- ▶ Durable cast iron base and lift-out flange.
- ▶ Stainless steel pump adapter and guide plate.

## STATIONARY ELBOW

Cast iron ASTM A-48 class 30.

## MOVABLE FITTING

Ductile iron ASTM A-536.

## GUIDE RAIL CAP

**Bracket:** 304 stainless steel.

**Plugs:** ductile iron ASTM A-536-84.

## HARDWARE

304 series stainless steel.

## O-RINGS

Buna-N, 70 ±5 Duro.

## PAINT

Air dry enamel, water based.

inch [mm]

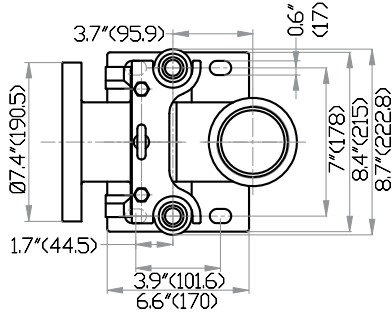
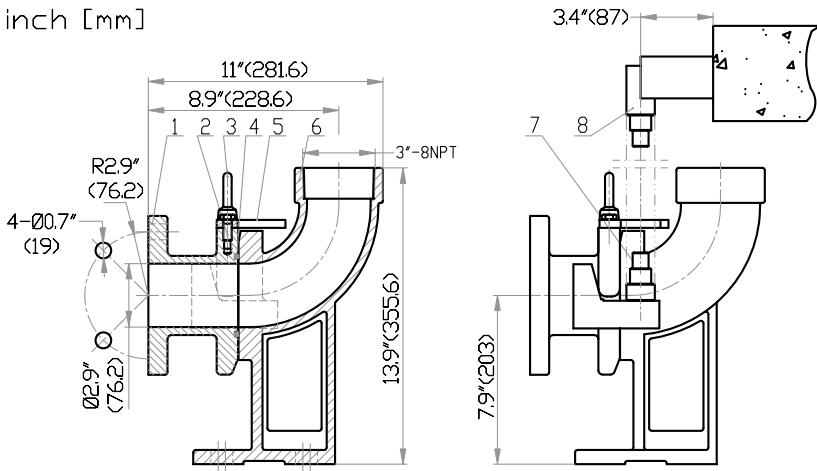

ITEM	QTY.	DESCRIPTION	MATERIAL
1	1	PULL OUT FLANGE	IRON 30B
2	2	SCREW HXHD 3/8"-16UNCx1"	SS304
3	1	SHACKLE 3/8"-16UNC FOR LIFT CABLE OR CHAIN (BOTH NOT INCLUDED)	420
4	1	O-RING Ø90x5	BUNA
5	1	LOWER GUIDE PLATE	SS304
6	1	BASE ELBOW	IRON 30B
7	2	DOWEL PIN	SS304
8	1	UPPER GUIDE BRACKET	SS304

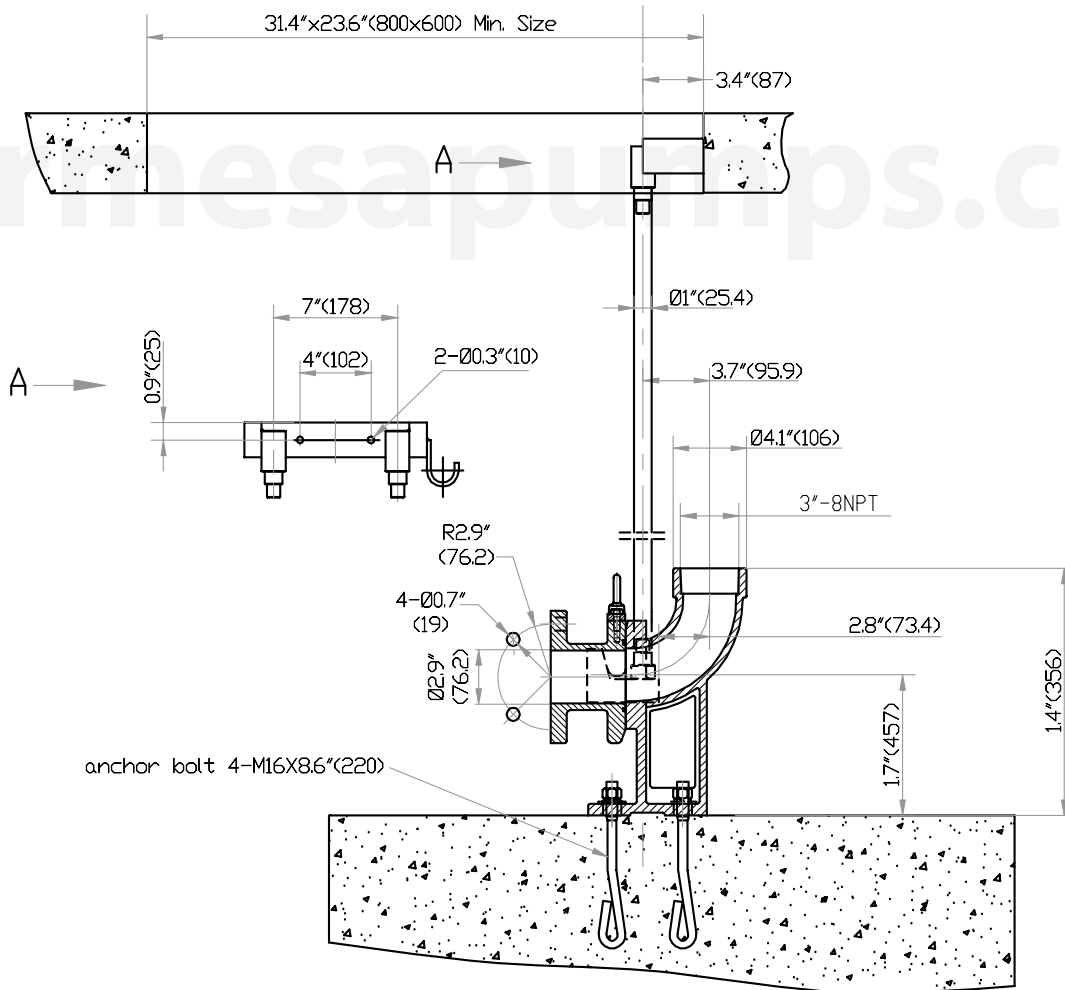

MODEL	PART No.	SIZE	RAILS	COUPLING	WEIGHT (pounds)
SRCH300	-	3"	1"	w/ upper guide bracket	66.1