

SRC-8

To be used with
8BSE series pumps.



IMPORTANT! - Read all instructions in this manual before operating or servicing this accessories.

Before installation, read the following instructions carefully. Failure to follow instruction and safety information could cause serious bodily injury, death and/or property damage. Each Barmesa product is carefully inspected to insure proper performance. Closely following these instructions will eliminate potential operating problems, assuring years of trouble-free service.

⚠ DANGER "Danger" indicates an imminently hazardous situation which, if not avoided, WILL result in death or serious injury.

⚠ WARNING "Warning" indicates an imminently hazardous situation which, if not avoided, MAY result in death or serious injury.

⚠ CAUTION "Caution" indicates a potentially hazardous situation which, if not avoided, MAY result in minor or moderate injury.

IMPORTANT! - Barmesa Pumps is not responsible for losses, injury or death resulting from failure to observe these safety precautions, misuse, abuse or misapplication of pumps or equipment.

ALL RETURNED PRODUCTS MUST BE CLEANED, SANITIZED, OR DECONTAMINATED PRIOR TO SHIPMENT, TO INSURE EMPLOYEES WILL NOT BE EXPOSED TO HEALTH HAZARDS IN HANDLING SAID MATERIAL. ALL APPLICABLE LAWS AND REGULATIONS SHALL APPLY.

⚠ WARNING Installation, wiring, and junction connections must be in accordance with the National Electric Code and all applicable state and local codes. Requirements may vary depending on usage and location.

⚠ WARNING Installation and servicing is to be conducted by qualified personnel only.



Keep clear of suction and discharge openings. Do not insert fingers in Slide Coupling or pump with power connected; the rotating cutter and/or impeller can cause serious injury.



Always wear eye protection when working on pumps. Do not wear loose clothing that may become entangled in moving parts.



⚠ DANGER Pumps build up heat and pressure during operation. Allow time for pumps to cool before handling or servicing the pump or any accessory items associated with or near the pump.



⚠ DANGER Barmesa pumps or Barmesa Slide Couplings are not intended for use in swimming pools or water installations where there is human contact with pumped fluid.



⚠ DANGER To reduce risk of electric shock, always disconnect pump from power source before handling any aspect of the pumping system. **Lock out power and tag.**



⚠ DANGER During use of the Barmesa BSR slide coupling or any installation or retrieval of a pump, **do not** lift, carry or hang pump by the electrical cables. Damage to the electrical cables can cause shock, burns or death. **Never** handle connected power cords with wet hands. Use appropriate lifting device.

⚠ WARNING Slide Couplings as well as pumps often handle materials which could cause illness or disease. Wear adequate protective clothing when working on a used pump or piping. Never enter a basin after it has been used.



⚠ DANGER Failure to permanently ground the pump, motor and controls before connecting to power can cause shock, burns or death.

MODEL:	SRC-8
LOCATION:	This SRC-8 is designed for wet wells, tanks, or lift stations where it is necessary to remove a pump from service and reinstall the pump without maintenance personnel entering the pit to unbolt the pump flanges.
STATIONARY ELBOW:	Cast iron ASTM A-48 class 30.
MOVABLE FITTING:	Cast iron ASTM A-48 class 30.
GUIDE RAIL CAP:	Bracket: 304 stainless steel. Plugs: rubber and steel.
HARDWARE:	300 series stainless steel.
GASKETS:	Rubber.
PAINT:	Air dry enamel, water based.

barmesapumps.com

► Introduction

The Slide Rail Couplings (SRC) are precision engineered and manufactured of the highest quality castings. Each one is individually inspected by a quality assurance program to allow years of continuous service. Through proper installation this unit will provide superior service. This manual will provide basic information for installation, maintenance, and repair.

► Receiving

Upon receiving this unit, inspect it for damage or shortages. If damage has occurred, file a claim immediately with the delivery company that delivered your equipment. If the manual is removed from the crating, do not lose or misplace it.

► Storage

This unit has been packaged and protected for shipping and indoor storage. If it is to be stored outside for an extended period, additional protection is suggested.

Short Term - For best results, place the Barmesa Slide Coupling (SRC), in a dry atmosphere with constant temperature for up to six (6) months.

Long Term - Any length of time exceeding six (6) months, but not more than twenty four (24) months. The units should be stored in a temperature controlled area, a roofed over walled enclosure that provides protection from the elements (rain, snow, wind blown dust, etc.), and whose temperature can be maintained between +40°F and +120°F. If extended high humidity is expected to be a problem, all exposed parts should be inspected before storage and all surfaces that have the paint scratched, damaged, or worn should be recoated. All surfaces should then be sprayed with a rust-inhibiting oil.

► Service Centers

For the location of the nearest Service Center, check your Barmesa Pumps representative.

► Installation

Location - The Slide Rail Coupling model SRC-8, when used in conjunction with Barmesa Pumps 8" Submersible Non-Clog (series 8BSE), is recommended for operation in a wet well, tank, or lift station.

Design Layout - Models SRC-8 assembled with pumps listed before can be installed through access covers with size of 36" x 48" opening, for each pump.

Figures 1 through 4 provide clearance dimensions, guide pipe locations, and proposed anchor bolt locations at the access cover opening. It is recommended that the guide rail cap be installed with 5/8 inch stainless steel anchors.

Figures 1 through 4 also provides the required anchor bolt locations for the stationary elbow to be installed with four anchor bolts set in a metal sleeve and accurately set into concrete.

Hook bolts can be used, however, they are more difficult to locate in concrete. Use required shims under the stationary elbow base to level the horizontal flange and then grout under the base as required. A 30 day concrete cure is required before a full load can be applied to the anchor bolts. Design the anchor bolts for 1.6 kip uplift per bolt.

The 3" schedule 40 guide rail pipes must be plumbed after mounting on the stationary base elbow plugs. Pipe material may be galvanized steel or stainless steel (optional from manufacturer or supplied by customer).

Installing Pump to Slide Rail Coupling - These instructions apply to all Barmesa pumps with a 125 lbs flange horizontal discharge on volute. All parts for standard and non-sparking SRC's are the same except for moveable assembly. SRC-8 standard assemblies use a cast iron moveable assembly.

Insert and tighten studs (7) and (11) into pump volute as shown in Figure 5. Position moveable (2) onto pump volute over studs and apply lockwashers (9) and hex nuts (8) onto studs and torque each to 75/85 ft/lbs.

Installation Descent Speed - When lowering pump into wet well on the guide rails, do not exceed a descent speed of 3.2 inches per second or 16 feet per minute.

inches
(mm)

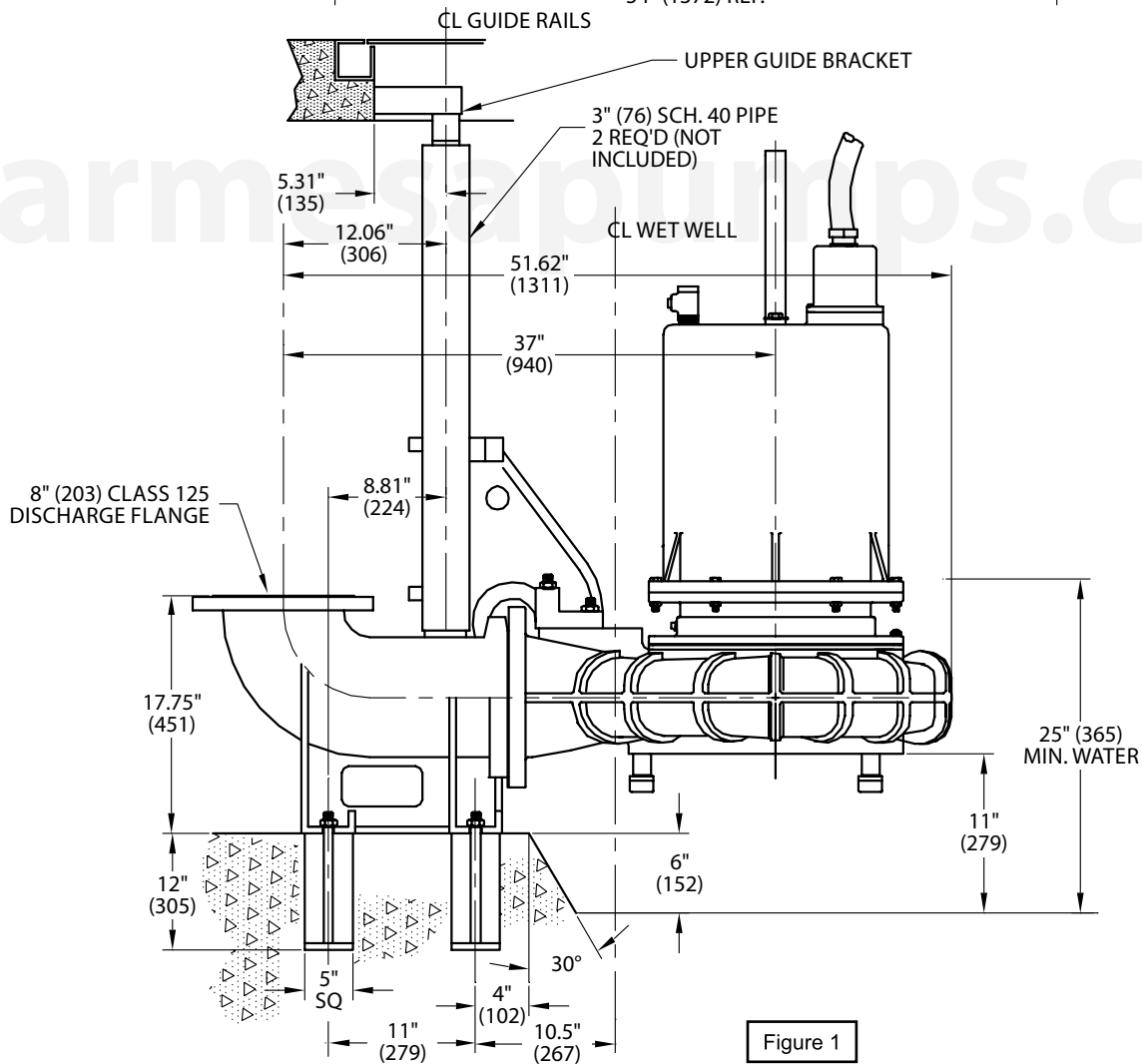
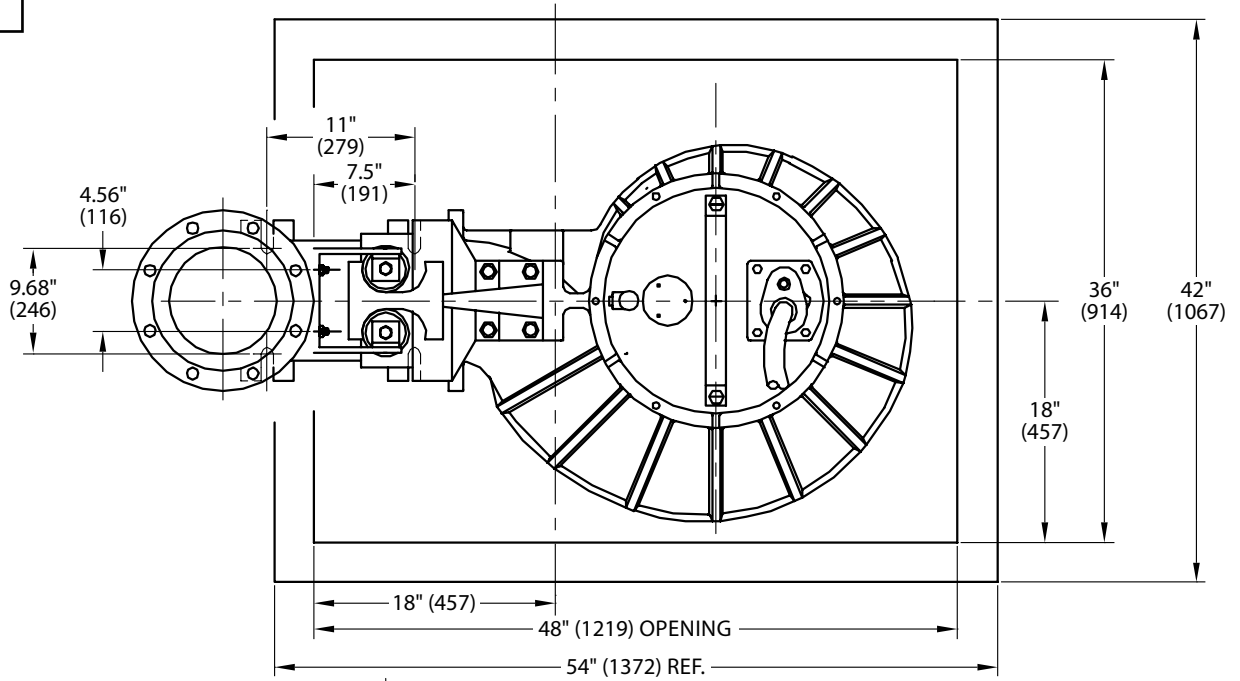

Figure 1

► Maintenance and Repair

Maintenance - Whenever the pump is lifted for inspection, it is recommended any foreign material be flushed from moveable fitting, guide plugs, and stationary base elbow face before replacement in wet well.

Repair - NOTE: All item numbers in () refer to Figure 5.

Guide Rail Cap - To replace guide plug(s) (3A) on upper guide bracket (3), remove cotter pin (3D) and cap screw (3C) from disk (3B). Inspect plug (3A) for damage or cuts and replace if required. Reassemble by placing plug (3A) on tab of bracket (3), place disk (3B) on other end and insert screw (3C), screw into disk and tighten. Place cotter pin (3D) into capscrew (3C).

► Replacement Parts

Ordering Replacement Parts - When ordering replacement parts, always furnish the following information:

1. Product Model
2. Part Description
3. Part Number
4. Quantity Required
5. Shipping Instructions
6. Billing Instructions

Product improvements are made from time to time. The latest part design will be furnished if it is interchangeable with the old part.

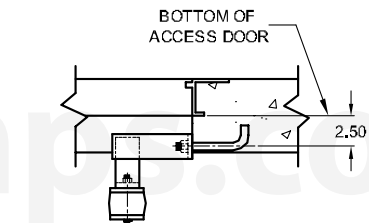
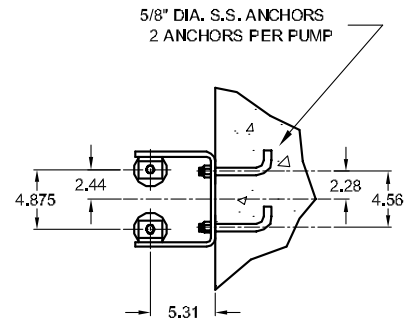
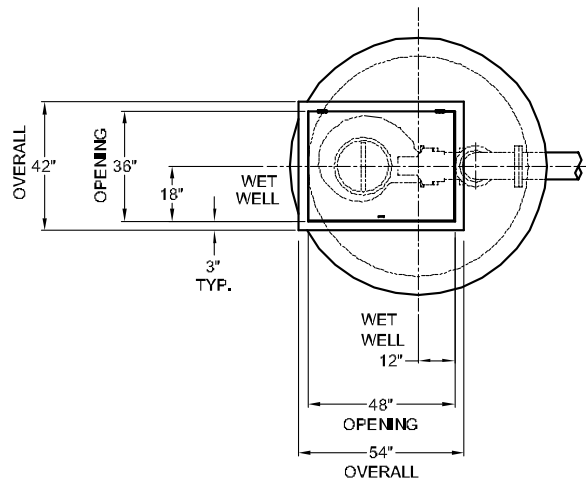

UPPER GUIDE RAIL
HOLDER MOUNTING

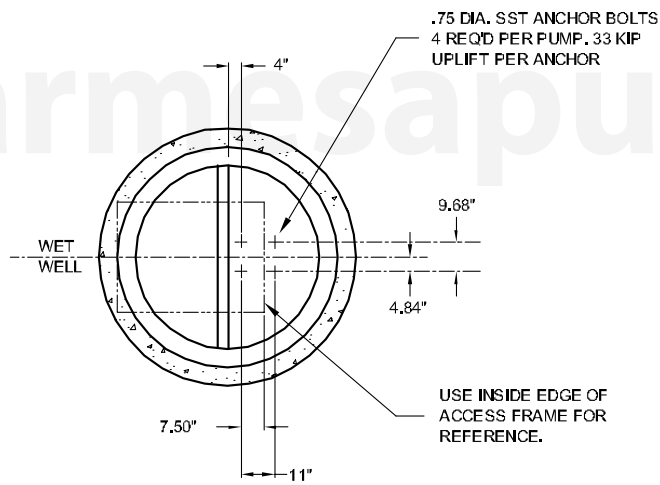

ANCHOR BOLT LAYOUT

Figure 2

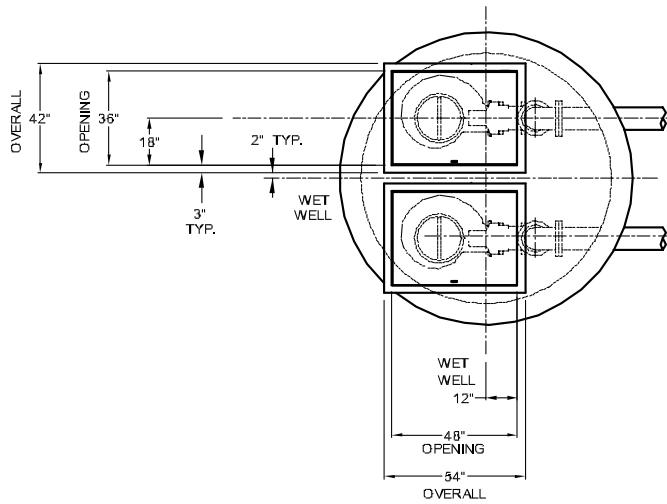

COVER LOCATIONS

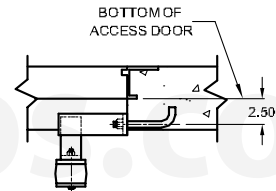
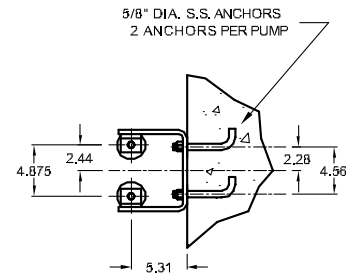

UPPER GUIDE RAIL
HOLDER MOUNTING

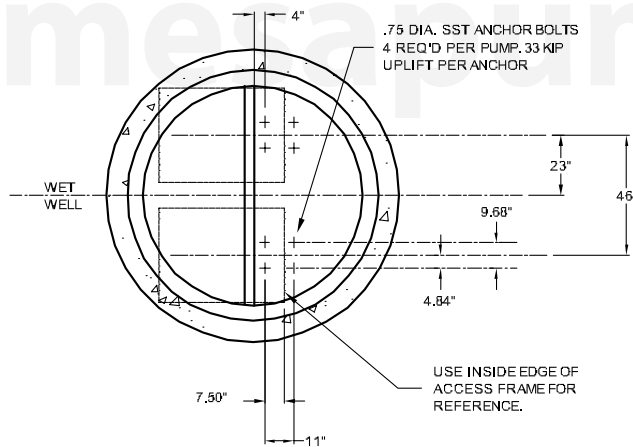

ANCHOR BOLT LAYOUT

Figure 3

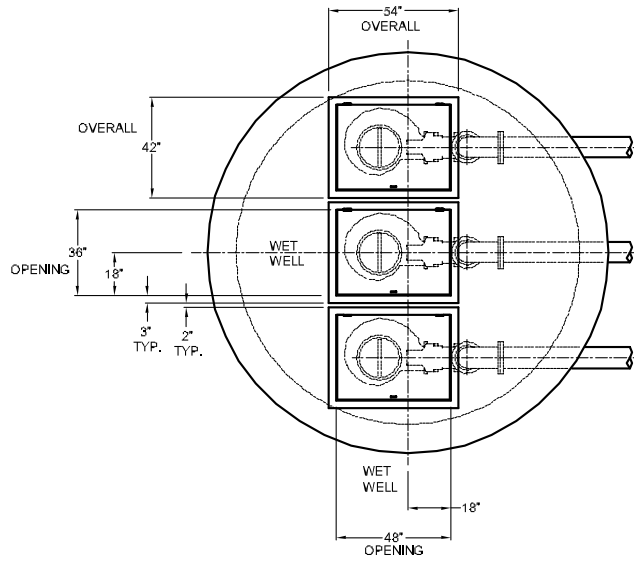

COVER LOCATIONS

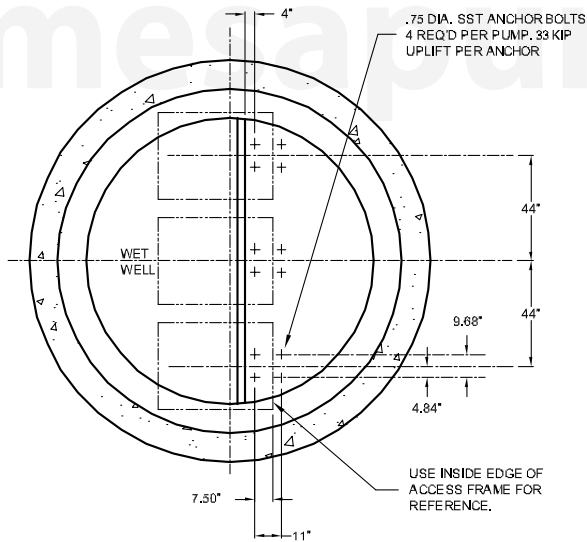
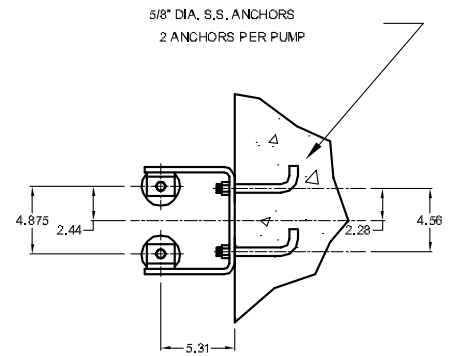

ANCHOR BOLT LAYOUT

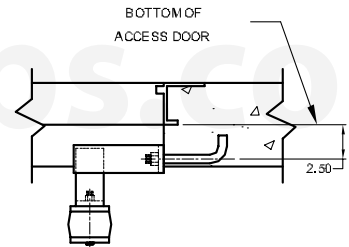

UPPER GUIDE RAIL
HOLDER MOUNTING

Figure 4

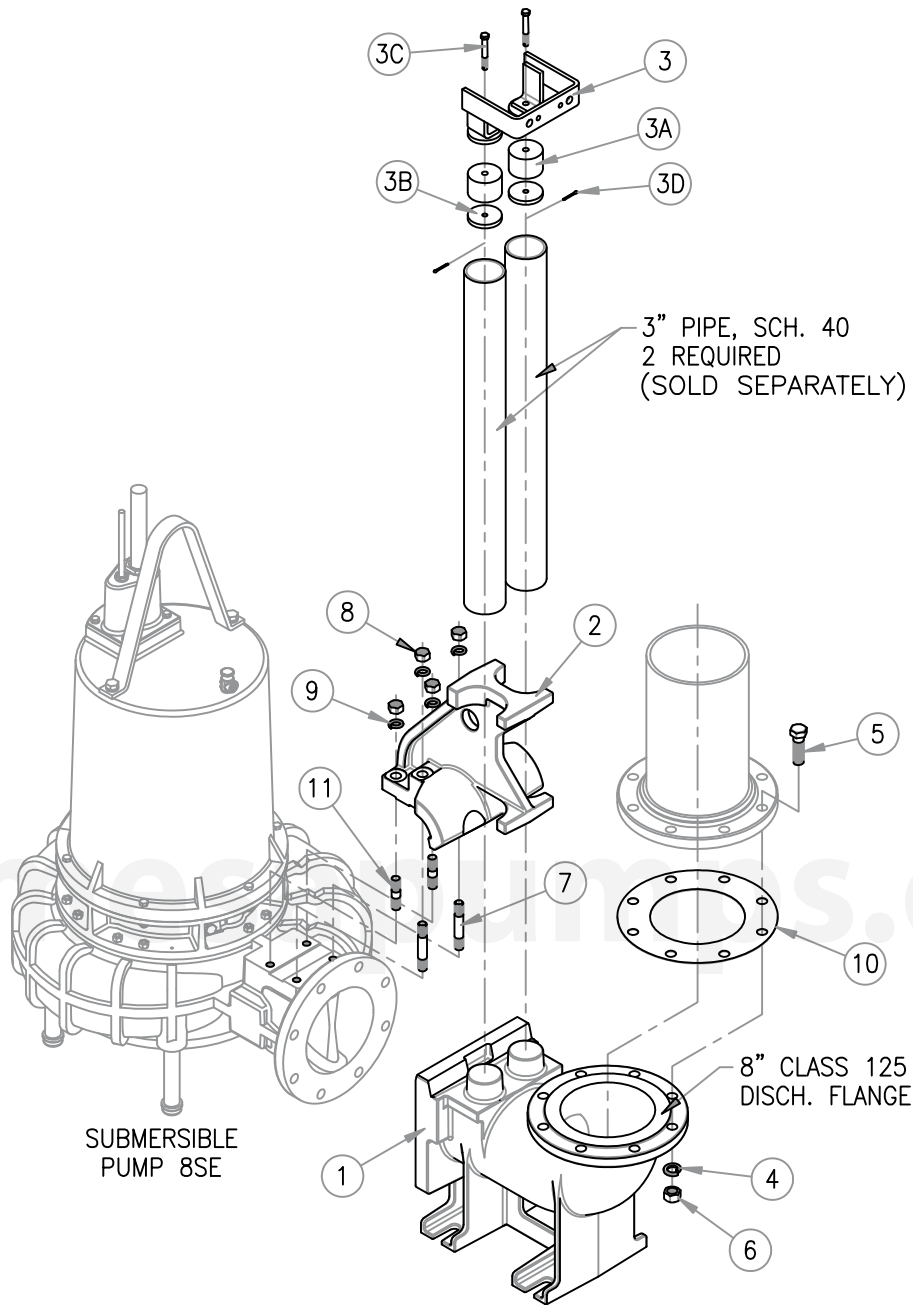

ITEM	QTY.	PART NO.	DESCRIPTION
1	1	-	Stationary Elbow Assembly
2	1	-	Moveable
3	1	-	Upper Guide Bracket
3A	2	-	Plug Rubber
3B	2	-	Threaded Disk
3C	2	-	Hex Hd Screw 7/16-14 x 3.25" Lg, Steel
3D	2	-	Cotter Pin 1.25" Dia. x 1.00" Lg
4	8	-	Lock Washer 7/8", Stainless
5	8	-	Hex Hd Screw 7/8-9 x 3" Lg
6	8	-	Hex Nut 7/8-9
7	2	-	Stud 3/4-10 x 4-3/4" Lg, Stainless
8	4	-	Hex Nut 3/4-10, Stainless
9	4	-	Lock Washer 3/4, Stainless
10	2	-	Gasket
11	2	-	Stud 3/4-10 x 3-1/8" Lg, Stainless

BARMESA PUMPS FACTORY WARRANTY

Barmesa Pumps warrants that products of our manufacture will be free of defects in material and workmanship under normal use and service for 18 months from date of manufacture or 12 months from installation date whichever occurs first. This warranty gives you specific legal rights, which vary from state to state.

This warranty is a limited warranty, and no warranty related claims of any nature whatsoever shall be made against Barmesa Pumps, until the ultimate consumer or his/her successor notifies us in writing of the defect and delivers the product and/or defective part(s) freight prepaid to our factory or nearest authorized service station as instructed by Barmesa Pumps. THERE SHALL BE NO FURTHER LIABILITY, WHETHER BASED ON WARRANTY, NEGLIGENCE OR OTHERWISE. PRODUCT SHALL BE EITHER REPLACED OR REPAIRED AT THE ELECTION OF BARMESA PUMPS. Guarantees relating to performance specifications provided in addition to the foregoing material and workmanship warranties on a product manufactured by Barmesa Pumps, if any, are subject to possible factory testing. Any additional guarantees, in the nature of certified performance specifications or time frame must be in writing and such writing must be signed by our authorized factory manager at time of order placement and/or at time of quotation. Due to inaccuracies in field testing and should a conflict arises between the results of field testing conducted by or for the user, Barmesa Pumps reserves the right to have the product returned to our factory for additional testing.

This warranty shall not apply when damage is caused by (1) improper installation, (2) improper voltage, (3) lightning, (4) excessive sand or other abrasive material, (5) corrosion build-up due to excessive chemical content or (6) uncontrollable acts of god. Any modification of the original equipment will also void the warranty. We will not be responsible for loss, damage or labor cost due to interruption of service caused by defective pumps, parts or systems. Barmesa Pumps will not accept charges incurred by others without our prior written approval.

This warranty is void if our inspection reveals the product was used in a manner inconsistent with normal industry practice and/or our specific recommendations. The purchaser is responsible for communication of all necessary information regarding the application and use of the product. UNDER NO CIRCUMSTANCES WILL WE BE RESPONSIBLE FOR ANY OTHER DIRECT OR CONSEQUENTIAL DAMAGES, INCLUDING BUT NOT LIMITED TO TRAVEL EXPENSES, CONTRACTOR FEES, UNAUTHORIZED REPAIR SHOP EXPENSES, LOST PROFITS, LOST INCOME, LABOR CHARGES, DELAYS IN PRODUCTION, IDLE PRODUCTION, WHICH DAMAGES ARE CAUSED BY ANY DEFECTS IN MATERIAL AND/OR WORKMANSHIP AND/OR DAMAGE OR DELAYS IN SHIPMENT. THIS WARRANTY IS EXPRESSLY IN LIEU OF ANY OTHER EXPRESS OR IMPLIED WARRANTY. No rights extended under this warranty shall be assigned to any other person, whether by operation of law or otherwise, without our prior written approval.

IMPORTANT!

If you have a claim under the provision of the warranty, contact Barmesa Pumps or your authorized Barmesa Pumps Distributor:

warranty@barmesapumps.com

1-844-BARMESA (227-6372)

www.barmesapumps.com



Barmesa®
Pumps

