

OPERATION AND MAINTENANCE MANUAL

First Edition



ROTOFLO

Wellpoint De-Watering Pump

Rotary Lobe Pumps

Onsite Maintenance

Extremely Low Downtime

Low Operating Cost

Simple & Inexpensive



CONTENTS

I. Design Overview of Major Components	2
Table 1. Capacity per Pump Model	2
A. Flanges	3
B. Drive Specifications	3
C. Mechanical Seals	3
II. Operation and Maintenance	3
A. Timing Gear Oil Changes	3
Table 2. Oil Volume per Pump Model	4
Table 3. Timing Gear Chamber Approved Oils	4
B. Intermediate Chamber Oil Changes	4
C. Start-up Check List	4
D. Quick Release Cover Removal	5
E. Cleaning of ROTOFLO	5
F. Screw Rotor Tip Replacement (RWP008, RWP010, RWP012)	6
G. Screw Rotor Replacement (RWP008, RWP010, RWP012)	7
H. Screw Rotor Replacement (RWP006)	9
I. Radial Liner Replacement (RWP006, RWP008, RWP010, RWP012)	10
J. Mechanical Seal Replacements (RWP006, RWP008, RWP010, RWP012)	11
K. Adjustment of the Axial Tolerance of the Rotor (RWP006, RWP008, RWP010, RWP012)	12
III. Troubleshooting	13
IV. Appendix	14
Spare Parts List for Pump Model RWP006	14
Diagram 1	15
Spare Parts List for Pump Models RWP008, RWP010, RWP012	16
Diagram 2	17
Additional Spare Parts for Pump Model RWP012 Support Bearings	18
Diagram 3	19
Drive Coupling Alignment Tolerances	20

I. Design Overview of Major Components

Table 1. Capacity per Pump Model

MWI Model	Displacement	Maximum Capacity	Maximum Head
RWP006	0.72 gal/rev	540 gpm/32,400 gph	210 ft
RWP008	2.20 gal/rev	1,650 gpm/99,000 gph	277 ft
RWP010	3.00 gal/rev	2,260 gpm/135,600 gph	210 ft
RWP012	4.40 gal/rev	3,330 gpm/199,800 gph	210 ft

The MWI RWP008, RWP010, RWP012 rotary lobe pumps are designed on a modular basis and share the same gear unit, axial wear plates, cover, and mechanical seal; RWP006 rotary lobe pump does not share these same components as the larger size models. The RWP012 has additional support bearings that are not found on the other models.

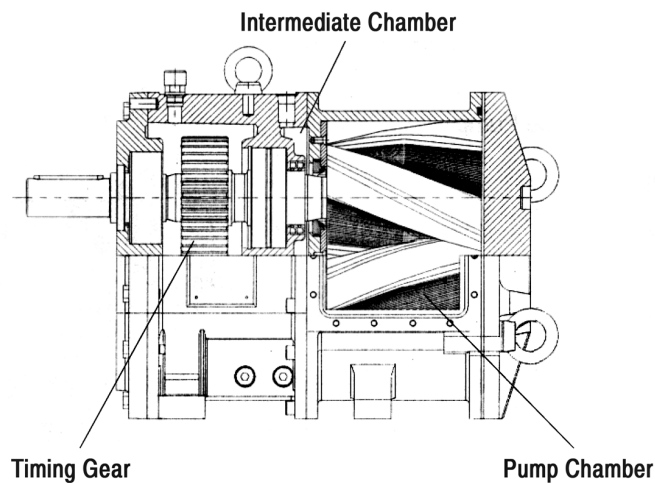
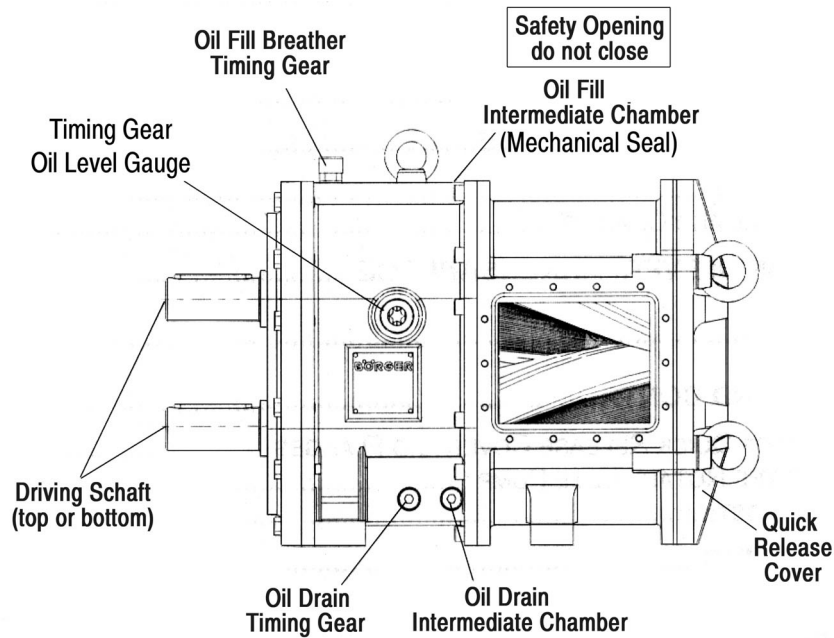

A. Flanges

Gaskets are required between the pump housing and the flanges of the mating components. The gasket material needs to be chemically compatible with the fluid to be pumped. The gasket material choices are EPDM, FPM, NBR, and PTFE.

B. Drive Specifications

MWI rotary lobe pumps are equipped with suitable prime movers capable of meeting speed and torque requirements of the pump. Prime mover ratings are determined by the hydraulic conditions of the application: flow capacity, head, and fluid viscosity. As a standard, MWI provides a variable speed diesel engine, gear reducer with manual clutch, suitable shaft coupling, and protective guard. MWI can also provide optional arrangements, such as a hydraulic motor directly coupled to the pump shaft upon request. The operation and maintenance of the engine and gear reducer are not included in this manual. Please reference the manufacturer's manual for details on these components.

C. Mechanical Seals

The ROTOFLO utilizes a single acting mechanical seal consisting of a stationary seat and a rotating element, each with a seal face. The seal is located in the intermediate chamber and is quenched with oil. Centrifugal and capillary action forces the oil between the seal faces. This in turn lubricates the seal gap and removes developing heat from the seal faces. Pumped fluid is not required to lubricate or cool the mechanical seal. If the mechanical seal is exposed during maintenance, it is recommended to replace the mechanical seal assembly regardless of the seal condition.

II. Operation and Maintenance

A. Timing Gear Oil Changes

Check the oil level in the timing gear chamber prior to startup. The oil level must be at the middle of the oil level gauge. The oil in the timing gear chamber needs to be changed after the first 250 hours of operation. After this break-in period, the oil needs to be changed every six months for units subject to continuous operation and once a year for units subject to intermittent operation. Refer to Table 2 for volume of oil required per ROTOFLO model.

MWI Pump Model	Timing Gear Chamber Oil Quantity
RWP006	1.5 liter (0.4 gal)
RWP008	5.6 liter (1.48 gal)
RWP010	5.6 liter (1.48 gal)
RWP012	5.6 liter (1.48 gal)

Table 3. Timing Gear Chamber Approved Oils

Type of Lubricant	Ambient Temperature °C	VISCOSITY	ARAL	BP	CASTROL	DEA	ESSO	Klüber	MOBIL	SHELL	TRIPOL
Mineral oil	-5... +40 (normal)	ISO VG 220	Degol EG 220	Energol GR-XP220	Alpha SP 220 Alpha MW 220	Deagear DK SAE 85W90 Falcon CLP 150	Spartan EP 220	Klüberoil GEM 1-220	Mobilgear 630	Shell Omala Gel 220	Tripol 1100/ 200
Mineral oil	-15... +25	ISO VG 100	Degol EG 100	Energol GR-XP100	Alpha SP100 Alpha MW100	Deagear DK SAE 80W Falcon CLP150	Spartan EP 100	Klüberoil GEM 1-100	Mobilgear 629	Shell Omala Gel 100	Tripol 1100/ 100
Mineral oil	-50... -15	ISO VG 15	Vitarol 1010	Bartan HV 15	Hyspin AWS 15 Hyspin SP 15	Airkraft Hydraulic Oil 15	Univis J 13	Isoplex MT 30 rot	Mobil DIE 11M	Shell Tellus Gel T15	Tripol 770

B. Intermediate Chamber Oil Changes

The intermediate chamber is where the mechanical seals are located. The functions of this chamber are:

- ✘ Lubrication and cooling of the mechanical seals and rotor/shaft connection
- ✘ Detection of seal failure
- ✘ Buffer zone to sealed timing gear chamber

The oil in the intermediate chamber must be monitored and refilled as needed. MWI provides a visible clear vented reservoir to monitor the oil level in the intermediate chamber. The reservoir oil level should not run dry. When changing mechanical seals, the intermediate chamber needs to be flushed and cleaned with water prior to filling the chamber with new oil. Oil used in the intermediate chamber must be mineral based rated ISO VG 68 when the pump is used in conditions with ambient temperatures of -15°C up to 40°C.

NOTE: Oil levels and oil changes for the prime mover need to be performed according to the manufacturer's manual.

C. Start-up Check List

- 1) Check shaft alignment. Correct if needed. (Reference Tolerances on Page 20).
- 2) Check oil levels in timing gear and intermediate chambers. Fill as needed.
- 3) Check all flanged and pipe connections to prevent leaks.

- 4) Verify prime mover rotation. The ROTOFLO is designed to operate in direction shown.

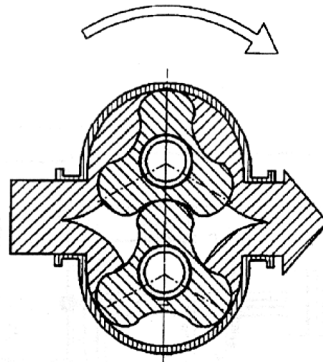

Top shaft rotates clockwise. Fluid flows in direction of arrow
(Viewed from quick release cover)

- 5) Verify that the necessary valves are open (depends on the application).

D. Quick Release Cover Removal

Refer to Diagram 2 in Appendix for pump models RWP008, RWP010, and RWP012. Refer to Diagram 1 for RWP006.

The following are precautions to be observed prior to removal of the quick release cover and flanges:

- 1) Close suction and discharge valves (if applicable).
- 2) Drain the suction and discharge reservoirs.
- 3) Lock out / tag out the prime mover and disengage the safety coupling.
- 4) Loosen ring nuts (item 50) on quick release cover by turning $\frac{1}{4}$ of a turn and slowly loosen the cover from the pump housing to relieve pressure. **CAUTION: remaining fluid may exit the housing under pressure through the gap between the housing and cover.**

E. Cleaning of ROTOFLO

In order to properly clean the unit remove the quick release cover by following the instructions in section D, then clean the pump interior and flanges with a suitable cleaning agent. Remove all solids and debris from the pump housing then let the pump housing dry and use a surface metal protection (grease) suitable for use with the rubber material of the rotors. MWI's standard rotor rubber material is NBR.

F. Screw Rotor Tip Replacement

(applicable only on models RWP008, RWP010, and RWP012)

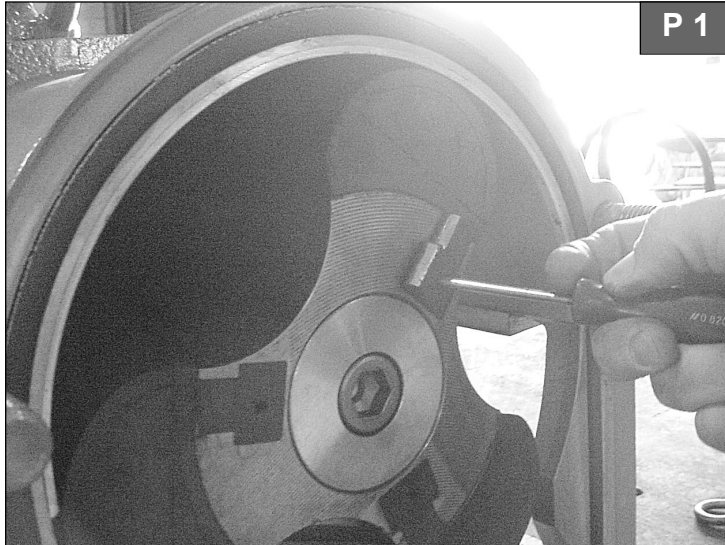

Refer to Diagram 2 in Appendix for a schematic of the pump chamber. Rotate the pump shaft with strapwrench until rotor tip to be replaced is not meshed in-between the other rotor tips.

1) Remove quick release cover as outlined in section D.

2) Use a screwdriver to remove the T-plug (item 9.3v) located over the head of the socket head cap screw (item 9.3t) on the rotor tip (**P 1**) that is not meshed with the other rotor. Remove the spacer (item 9.3w) over the head of the socket head cap screw.

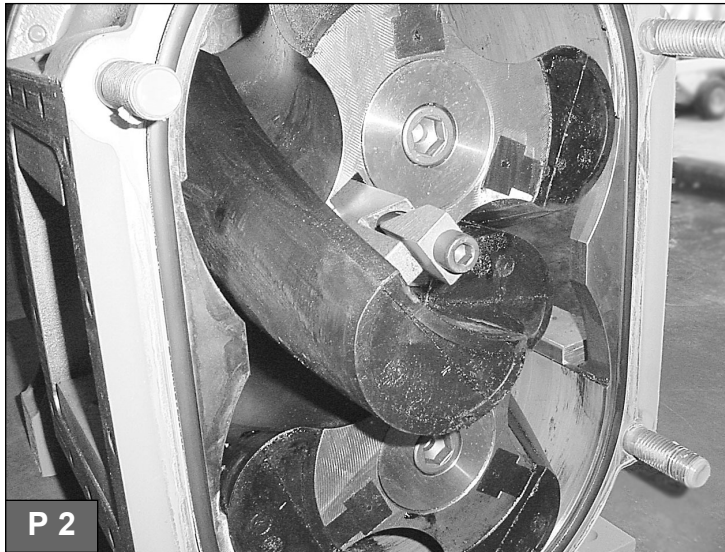

3) Loosen the socket head cap screw (item 9.3t) using a hexagon head socket wrench to open the retaining clamp (item 9.3s). After turning 5-8 revolutions, verify that the back clamp wing is loose; if not, strike the head of the fastener to open the clamp. When the clamp is open, the rotor tip can be removed (**P 2**). NOTE: The screw and front clamp wing can be removed. The clamp base has a 12 mm internal thread to utilize a puller to remove the screw rotor tip.

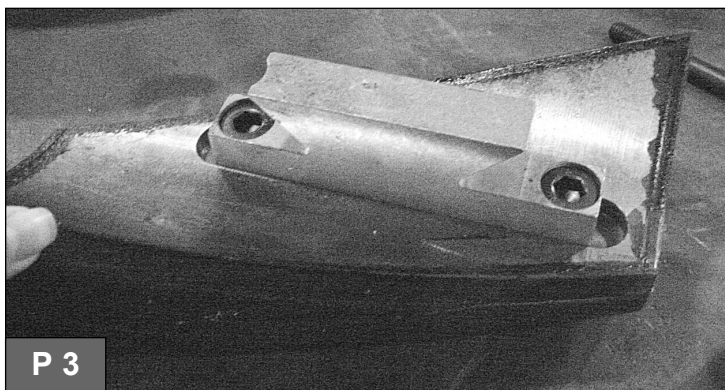

4) Remove clamp base from worn screw rotor tip (**P 3**) and fit it to new rotor tip applying the following torque depending on the fastener type

- ¥ Standard Fastener: 440 in-lb (50 N-m)
- ¥ Stainless Steel Fastener: 350 in-lb (40 N-m)

5) Push screw rotor tip (item 9.2s) onto the rotor body (item 9.1s) and tighten the socket head cap screw (item 9.3t) applying the following torque depending on the fastener type:

- ¥ Standard Fastener: 440 in-lb (50 N-m)
- ¥ Stainless Steel Fastener: 350 in-lb (40 N-m)

6) Repeat steps 6-9 until all screw rotor tips have been replaced.

7) After replacement of the rotor tips, verify the ease of motion of the rotors by rotating the pump shafts.

8) Place the spacer over the head of the socket head cap screw. Then drive in a new T-plug (using a hammer) until the T-plug is flush with the surface. If necessary, grind down the surface of the plug.

9) Verify the condition of the o-ring (item 30) in the quick release cover and reinstall on pump housing with the ring nuts (item 50).

G. Screw Rotor Replacement

(for pump models RWP008, RWP010, and RWP012)

Refer to Diagram 2 in Appendix for a schematic of the pump chamber.

1) Remove quick release cover as outlined in section D.

2) Remove one of the screw rotor tips which is not meshed with the other rotors as described in section F. Rotate the rotors 120° counterclockwise. See illustration below.

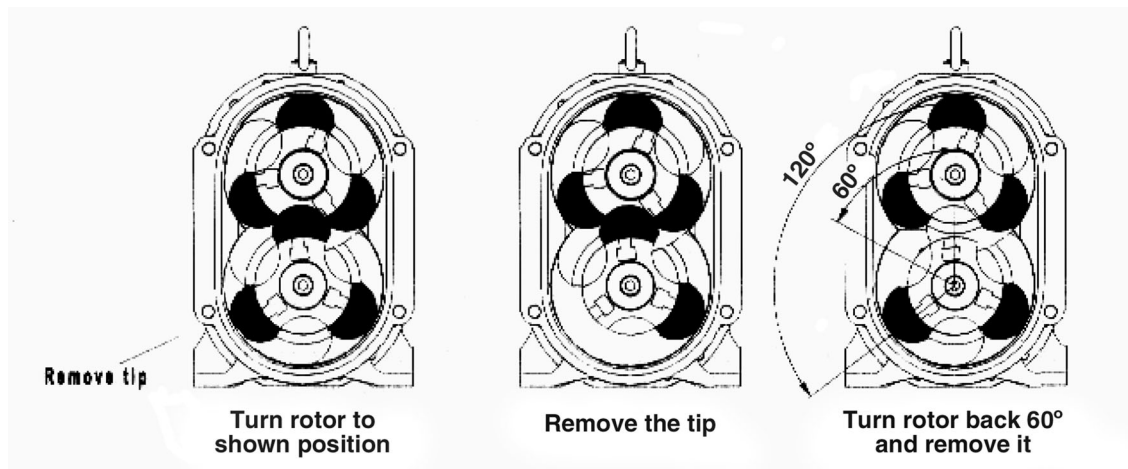

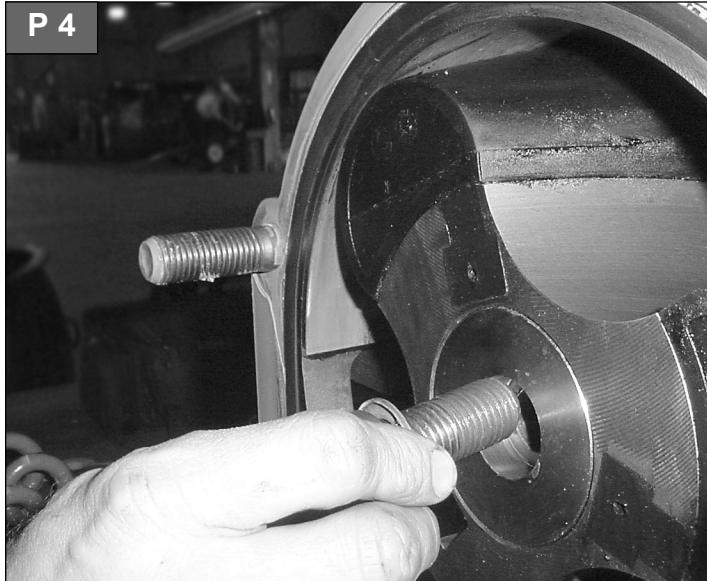

P 4

3) Remove the socket head cap screw (item 64) which holds the rotor in axial position on the shaft using a 17mm hex socket wrench. **(P 4)**

4) Remove the cover disks (item 24). **(P 5)**

5) Inspect the o-rings (item 31) and replace if needed.

6) Pulling off the rotor may require a special tool (item 90, 91) that clamps onto the rotor for ease in sliding it out. Make sure the rotors are in position according to the illustration (the side without the rotor tip is in-between the other rotor for easy removal). **(P 6)**



P 5

7) Oil the shafts and install the new rotors (item 9.1s); remove one screw rotor tip prior to installation.

8) Install cover disk (item 24) and secure with socket head cap screw fastener (item 64) and seal washer (item 74) using 1770 in-lb (200 N-m) of torque regardless of whether the fastener is standard or stainless steel.



P 6

9) Reinstall screw rotor tip as described in Section F after rotating the rotors 120° clockwise.

10) Inspect the o-ring on the quick release cover and replace if necessary. Reinstall cover on pump housing with the ring nuts.

H. Screw Rotor Replacement on model RWP006

Rotor tips are not replaceable on RWP006. If the rotor tips are worn, the entire rotor must be replaced. Refer to Diagram 1 in Appendix.

1) Remove quick disconnect cover as described in section D.

2) Remove the socket head cap screw (item 64) using a 14mm hexagon socket wrench. **(P 7)** Shafts can be retained by clamping with a part that has no sharp edges.

3) The rotor is internally threaded to utilize a 15mm puller to slide the rotor off the shaft. It may be necessary to rotate the rotors as you pull one out.

4) Oil the shafts and slide on new rotor. **(P 8)**

5) Install the hex head cap screw (item 64) by applying 1590 in-lb (180 N-m) for both standard screws and stainless steel screws.

6) Turn rotors by hand to make sure they move freely.

7) Reinstall the cover plate (item 10) (make sure the o-ring is in place) and cover and reattach the ring nuts.

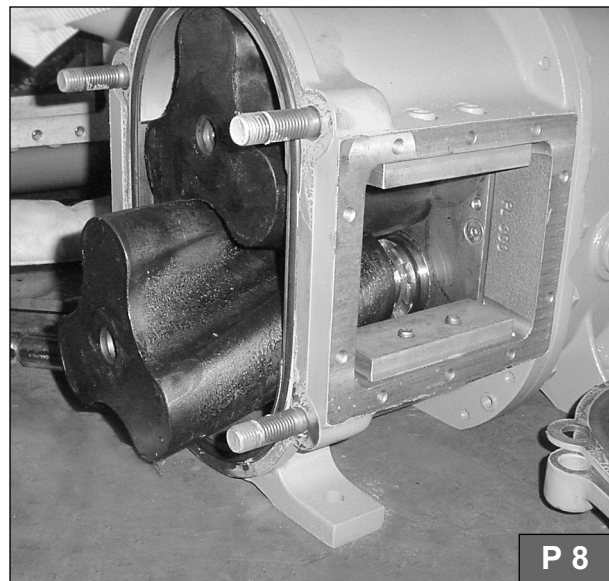
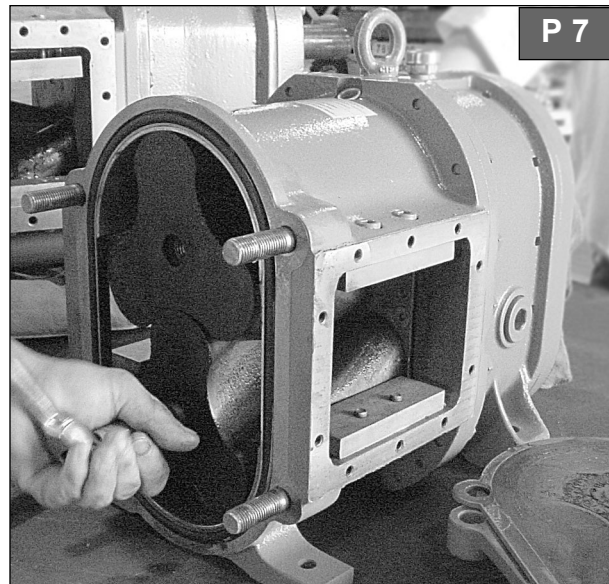

I. Radial Liner Replacement (for all pump models)

Refer to Diagram 2 for pump models RWP008, RWP010, and RWP012. Refer to Diagram 1 for pump model RWP006.

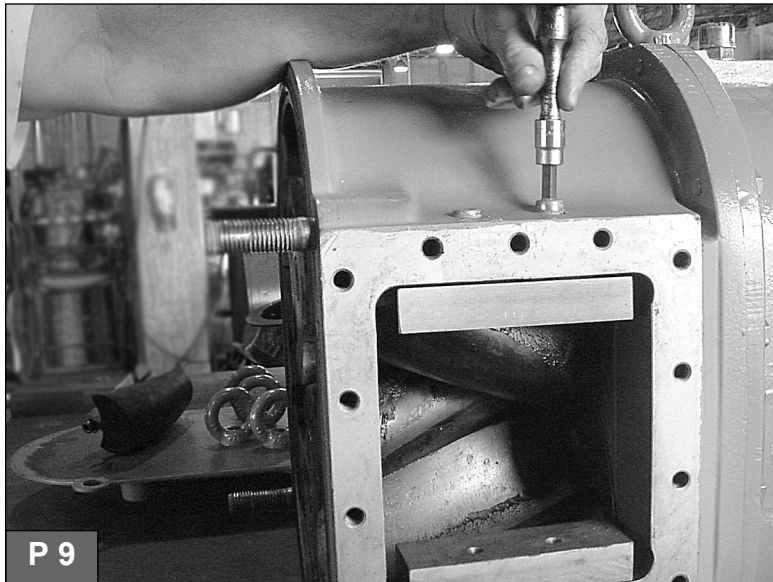

1) Remove quick disconnect cover as described in section D.

2) Loosen the clamp fasteners (item 12.2) holding the liners in place (items 12.3) using a 10 mm socket wrench. (P 9)

3) Remove the liners. (P 10) Liners may be difficult to remove by hand, if so, try using pliers to grab the edge.

4) Flush and clean the pump housing.

5) In order to reinstall the liners, it may be necessary to remove the rotors first as described in earlier sections.



6) Secure the liners by tightening the clamps (item 12.2) with the screws (items 12.3). Verify that the liners are centered in the pump housing.

7) Check for interference between the liners and screw rotor tips; readjust as necessary.

8) Reinstall the cover plate (item 10) (make sure the o-ring is in place) and cover and reattach the ring nuts.

J. Mechanical Seal Replacement (all pump models)

Refer to Diagram 2 for pump models RWP008, RWP010, and RWP012. Refer to Diagram 1 for pump model RWP006.

1) Drain oil from intermediate chamber through the oil drain (refer to Pump Illustration 1 on page 2).

2) Remove the rotors as described in Section H for pump model RWP006 or Section G for all other models.

3) Remove keys from shaft. **(P 11)** Unscrew the threaded holding bushing (item 14) from the shaft.

4) Remove the mechanical seal rings with o-rings (item 15) from the holding bushing and from the stationary seat (item 13). **(P 12)**

5) Clean, inspect, and oil all o-rings; replace damaged o-rings as needed.

6) Flush intermediate chamber to remove debris and wear particles.

7) Place o-rings on the new mechanical seal rings (item 15).

8) Press one seal ring onto the stationary seat (item 13). Place remaining seal ring onto the threaded holding bushing (item 14).

9) Screw the holding bushing onto the shaft until the shoulder is aligned with the wear plate (item 11). Then turn $\frac{1}{6}$ revolutions counterclockwise. The holding bushing projects approximately 0.3 mm into the wear plate. Ensure that one groove of the bushing is aligned with the shaft groove.

10) Place the long key into the aligned grooves of the bushing and the shaft. Place the shorter key in the front of the groove on the shaft.

11) Clean and oil the rotor surfaces.

12) Reinstall the rotors.

13) Reinstall the cover plate (item 10) (make sure the o-ring is in place) and cover and reattach the ring nuts.

14) Put oil into the intermediate chamber by filling the reservoir.

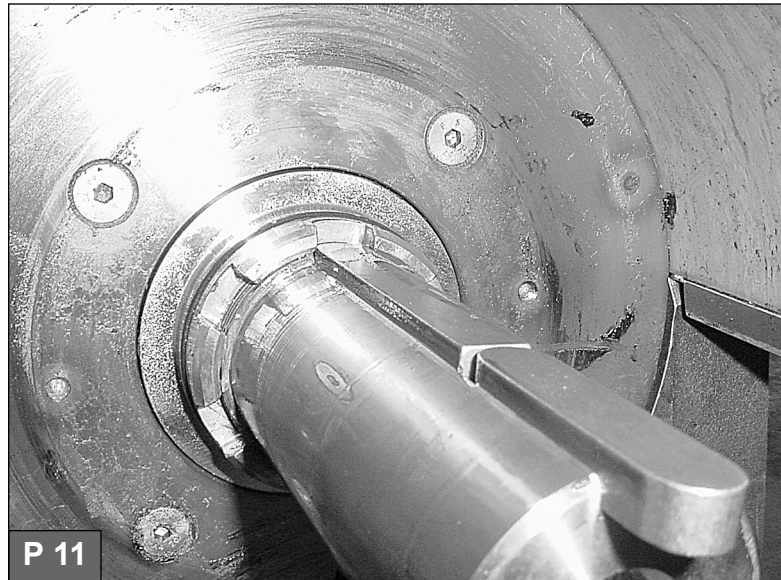

K. Adjustment of the Axial Tolerance of the Rotors (all pump models)

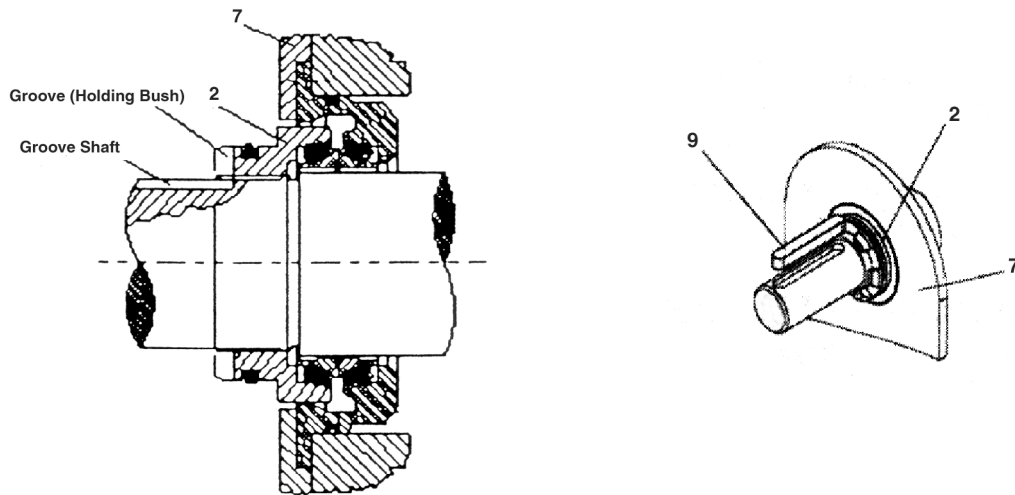

1) Remove the rotors as described in Section H for pump model RWP006 or Section G for all other models.

2) Take the keys (item 9) out of the shaft groove. **(P 11)**

3)

a) If the rotors are too tight to the quick release cover plate, then turn the threaded holding bushing (item 2) clockwise $\frac{1}{6}$ revolutions until the next groove in the bushing is aligned with the shaft groove.

b) If the rotors are too tight to the rear wear plate (item 7), then turn the threaded holding bushing (item 2) counterclockwise $\frac{1}{6}$ revolutions until the next groove on the bushing is aligned with the shaft groove.

WARNING: Do not unscrew the threaded bushing more than $\frac{1}{6}$ turn due to the danger of fluid leaking from the intermediate chamber.

4) Place the keys into the aligned grooves of the bushing and the shaft.

5) Reinstall the rotors.

III. Troubleshooting

Pump does not start after shutdown:

Cause	Solution
Solids have settled inside the pump after shutdown.	Remove quick release cover. Clean pump housing.
Rotors are swollen and are too tight for the pump housing.	Check temperature and chemical composition of pumped fluid. Change rotor to suitable rubber material.
Debris is blocking the pump.	Clean pump and suction.
Axial rotor tolerance interference.	Adjust axial rotor tolerance (see Section K).
Power and/or torque too weak.	Verify prime mover rating is suitable for application.
Thermal protection shutdown at pump suction.	Inspect suction plumbing for possible collapse or blockage, switch will reset at 110..F

Pump does not prime:

Cause	Solution
Suction pipe is blocked.	Clean suction pipe.
Suction connection has a leak.	Check gasket and flange connection and all joints in suction system.
Air bubble existing inside the pump or suction pipe system.	Fill suction tank or release air out of the system.
Rotor tips severely damaged.	Replace the rotor tips. Check temperature and chemical composition of pumped fluid. Change rotor tips to suitable rubber material.

Pump Cavitates:

Cause	Solution
Rotation speed too high: internal cavities are not filled with fluid.	Decrease rotation speed and/or increase suction pressure.
Solid is blocking suction side.	Remove solid.

Excessive oil consumption through intermediate chamber:

Cause	Solution
O-ring in mechanical seal is damaged.	Replace o-ring (see Section K).
Mechanical seal defect.	Replace the mechanical seal.

Spare Parts List for Pump Model RWP006

Refer to Diagram 1

Item No.	Description	Quantity
1	Gear Case PL	1
2	Gear Case Cover	1
3	Bearing Cap, Open	1
4	Bearing Cap, Closed	1
5	Pump Casing	1
8	Quick release Cover	1
9.4	Screw Rotor NBR PL300	1 cw /1 ccw
10	Cover Plate	1
11	Axial Casing Protection Plate	1
12.1	Radial Liners S/S	2
12.2	Liner Clamp	4
12.3	Socket Head Cap Screw, M10 x 50	8
12.4	Sealing Washer	8
13	Stationary Holding Bushing	2
14	Threaded Holding Bushing	2
15	Mechanical Seal	2
16	Driving Shaft	1 / 2
17	Short Shaft	1 / 0
19	Gear	2
25	Flange Gasket	2
30	O-ring, 792 x 7	1
31	O-ring, 54 x 4	2
33	O-ring, 80 x 3	2
36	Oil Seal, 45 x 70 x 10	1 / 2
37	Double Lip Oil Seal, 55 x 80 x 10	2
40	Cylindrical Roller Bearing	2
41	Self-aligning Roller Bearing	2
42	Sleeve, 50 x 55 x 20	2
43	Sleeve, 40 x 45 x 20	1 / 2
46	Key, 14 x 9 x 32	2
50	Ring Nut, M16	4
52	Countersunk Screw, M8 x 20	2
53	Stud, M16 x 45	4
55.1	Dowel Pin, 14 x 32	2
55.2	Dowel Pin, 14 x 40	2
56	Socket Head Screw, M8 x 20	20
57	Socket Head Screw, M10 x 30	12
58	Socket Head Cap Screw, M8 x 20	12
59	Socket Head Cap Screw, M10 x 40	12
60	Lifting Eye Bolt, M20	1
62	Key, 10 x 8 x 70	1 / 2
63	Key, 14 x 9 x 80/63	2
64	Socket Head Cap Screw, M16 x 40	2
65	Oil Gauge	1
66	Oil Drain Plug, R 1/2"	2
67	Vent Screw, R 1/2"	1
70	Sealing Washer, 33 x 39	1
71	Sealing Washer, 17 x 23	2
77	Circlip, J110	2
78	Blanking Plug, R 1"	1
90	Special Withdrawal Tool	

Diagram 1

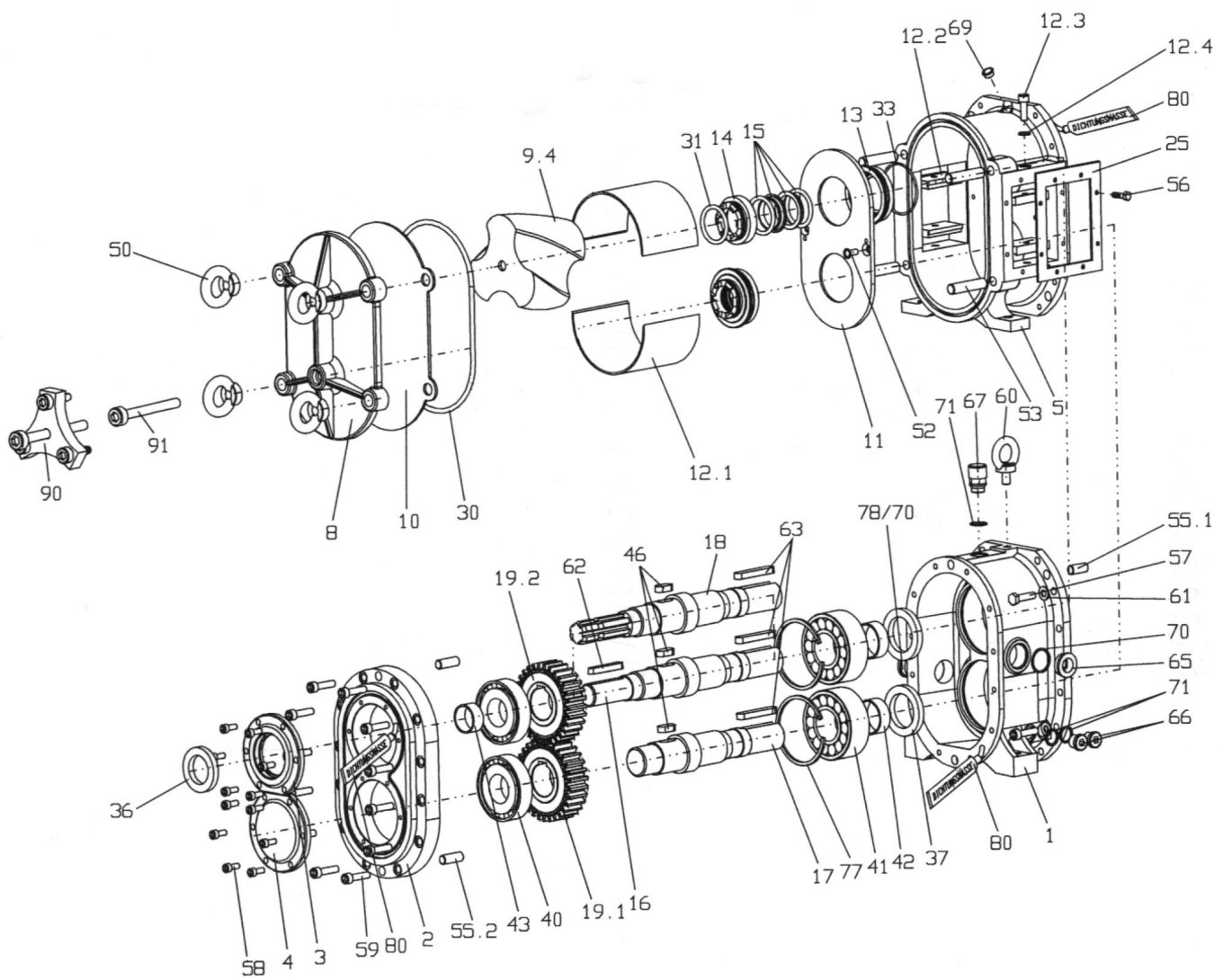

Spare Parts List for Pump Models RWP008, RWP010, RWP012

Refer to Diagram 2

Item No.	Part No.	Description	Quantity
1		Gear Case FL	1
2		Gear Case Cover	1
3		Bearing Cap, Open	1
4		Bearing Cap, Closed	1
5		Pump Casing	1
8		Quick release Cover	1
9.1s	RWPR2110L9	Screw Rotor Body, RWP008, CCW	1
9.1s	RWPR2110R9	Screw Rotor Body, RWP008, CW	1
9.1s	RWPR2210L9	Screw Rotor Body, RWP010, CCW	1
9.1s	RWPR2210R9	Screw Rotor Body, RWP010, CW	1
9.2s	RWPR3123R9	Screw Rotor Tip, RWP008, CW	3
9.2s	RWPR3113L9	Screw Rotor Tip, RWP008, CCW	3
9.2s	RWPR3213L9	Screw Rotor Tip, RWP010, CCW	3
9.2s	RWPR3223R9	Screw Rotor Tip, RWP010, CW	3
9.3s	RWPZ81009	Clamp for Screw Rotor Tip, RWP010	6
9.3s	RWPZ82009	Clamp for Screw Rotor Tip, RWP010	6
9.3t		Clamp Screw RWP008: M10 x 70 RWP010: M10 x 110 RWP012: M10 x 130	6
9.3u		Clamp Screw RWP008: M8 x 20 RWP010: M10 x 20 RWP012: M10 x 20	12
9.3v	RWPZ88889	T-plug	6
9.3w	RWPZ81509	Spacer Sleeve	6
10	RWPB31058	Cover Plate, Hardened Steel	1
10	RWPB31028	Cover Plate S/S	1
11	RWPB31048	Axial Casing Protection Plate	1
12.1	RWPB41220	Radial Liners, RWP008, S/S	2
12.1	RWPB41230	Radial Liners, RWP010, S/S	2
12.2	RWPB41250	Liner Clamp, RWP008	4
12.2	RWPB41260	Liner Clamp, RWP010	4
12.3		Socket Head Cap Screw, M10 x 50	8
12.4	RWPZ31249	Sealing Washer, A10 x 16. CU	8
13	RWPD35224	Stationary Holding Bushing	2
14	RWPD35114	Threaded Holding Bushing	2
14	RWPD35124	Threaded Holding Bush, S/S	2
15	RWPD35008	Mechanical Seal, Cast Iron	2
15	RWPD35008A	Mechanical Seal, Silicon Carbide	2
16		Driving Shaft	1 / 2
17		Short Shaft	1 / 0
19		Gear	2
24	RWPC70814	Cover Disk	2
25	RWPF81028	Flange Gasket, RWP008	2
25	RWPF81224	Flange Gasket, RWP010	2
30	RWP035408	O-ring, 1176 x 9	1
31	RWP035808	O-ring, 67 x 4	4
33	RWP035708	O-ring, 110 x 3	2
36		Oil Seal, 55 x 80 x 10	1 / 2
37	RWPS16308	Double Lip Oil Seal, 80 x 100 x 12	2
40		Cylindrical Roller Bearing	2
41		Self-aligning Roller Bearing	2
42		Sleeve, 70 x 80 x 25	2
43		Sleeve, 50 x 55 x 20	1 / 2
44		Support Ring, 60 x 75 x 3	2
46		Key, 18 x 11 x 60	2
50		Ring Nut, M20	4
52	RWPZ38208	Countersunk Screw, M8 x 20	8

Diagram 2

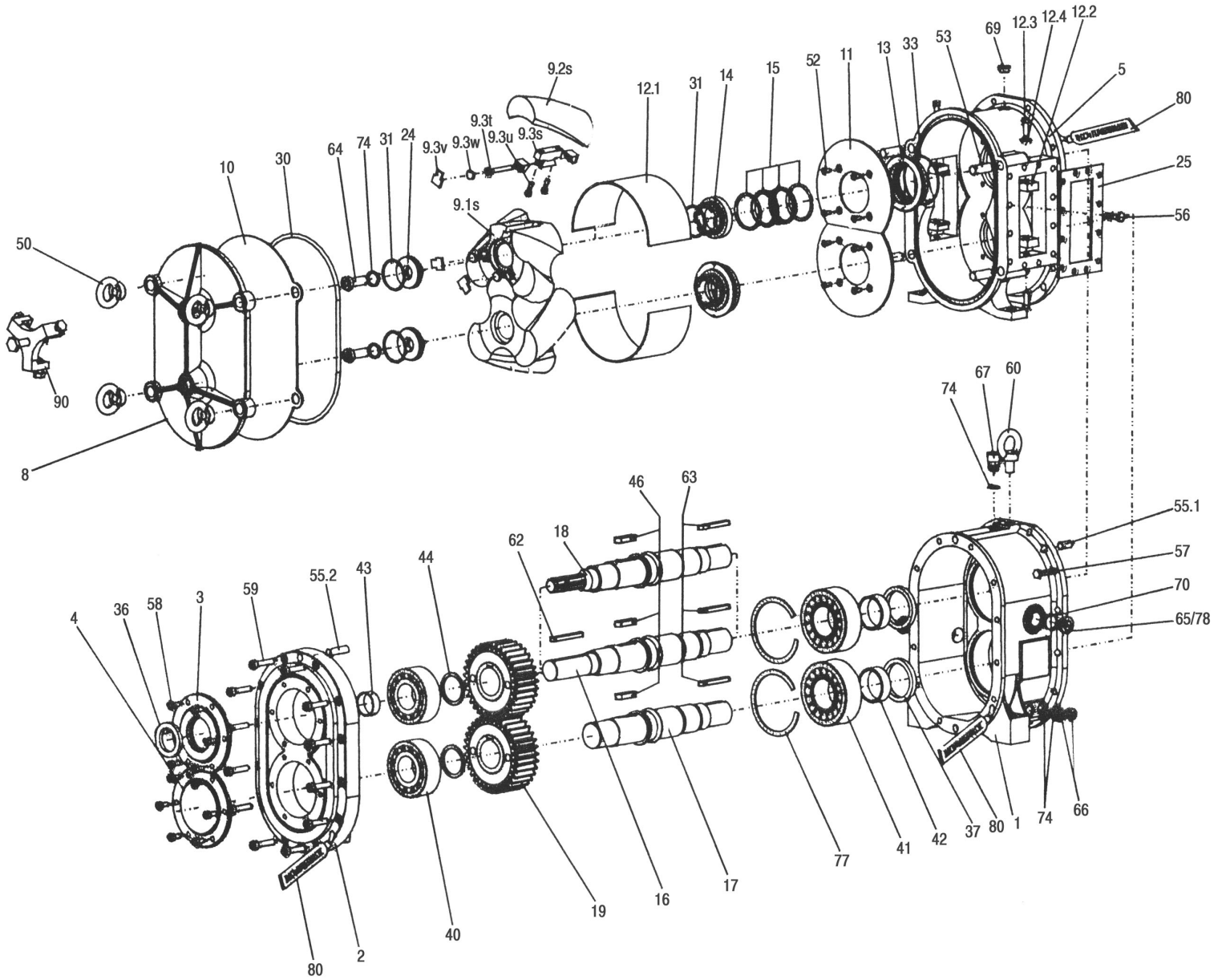

Item No.	Part No.	Description	Quantity
53		Stud, M20 x 55	4
55.1		Dowel Pin, 16 x 32	2
55.2		Dowel Pin, 16 x 60	2
56	RWPZ37308	Hex Head Screw, M12 x 30	RWP008: 28 RWP0101: 32 RWP012: 36
57		Hex Head Screw, M12 x 35	8
58		Socket Head Cap Screw, M10 x 20	12
59		Socket Head Cap Screw, M12 x 55	12
60		Lifting Eye Bolt, M20	1
62		Key, 14 x 9 x 100	1 / 2
63	RWPZ38134	Key, 14 x 9 x 100/118	2
63	RWPZ38124	Key, 14 x 9 x 100/56	2
64	RWPZ38154	Socket Head Cap Screw, M20 x 50	2
65		Oil Gauge	1
66		Oil Drain Screw, R 1/2"	2
67		Vent Screw, R 1/2"	1
70	RWPK22218	Sealing Washer, 33 x 39	2
74		Sealing Washer, 21 x 26	3
77		Circlip, J150	2
78		Gear Case Locking Screw, R1"	1
90	RWPU22808	Special Withdrawal Tool	

Additional Spare Parts for Pump Model RWP012 Support Bearings

Refer to Diagram 3

Item No.	Part No.	Description	Quantity
71	RWPK22308	Sealing Washer, 17 x 23	6
106		Locking Screw, G3/8"	4
111		Breather, R3/8"	2
119		Pump Casing Cover	1
120		O-ring, 130 x 3	4
126		O-ring, 48 x 4	2
128		Countersunk Screw, M5 x 16	2
129		Hexagon Head Screw, M5 x 35	8
133		Driving Shaft	1
134		Short Shaft	1
135		Tightening Nut	2
136		Bushing	2
137		Hollow Shaft	2
138		Parallel Key, A12P9x 8 x 30	2
139		Hardened Sleeve, 60 x 68 x 25	2
140		Oil Seal, 68 x 85 x 8	2
141		Cylinder Roller Bearing	2
142		Bearing Case	2
143		Locking Spring, 120 x 4	2
144		Locking Spring, 55 x 2	2
145		Hexagon Head Screw, M10 x 16	8
146		Bearing Case Cover	2
147		Hardened Sleeve, 50 x 55 x 25	2
148		Oil Seal, 55 x 70 x 8	2
149		Locking Slotted Round Nut, M35 x 1.5	2
150		Protecting Cap	2
151		O-ring, 42 x 3	2
152		O-ring, 58 x 2	2
153		Cover Protection Plate	1
154		Oil sight glass 3/8"	2
155		Countersunk Screw, M8 x 16	8
156		Adjusting Pin, 14 x 40	2

Diagram 3

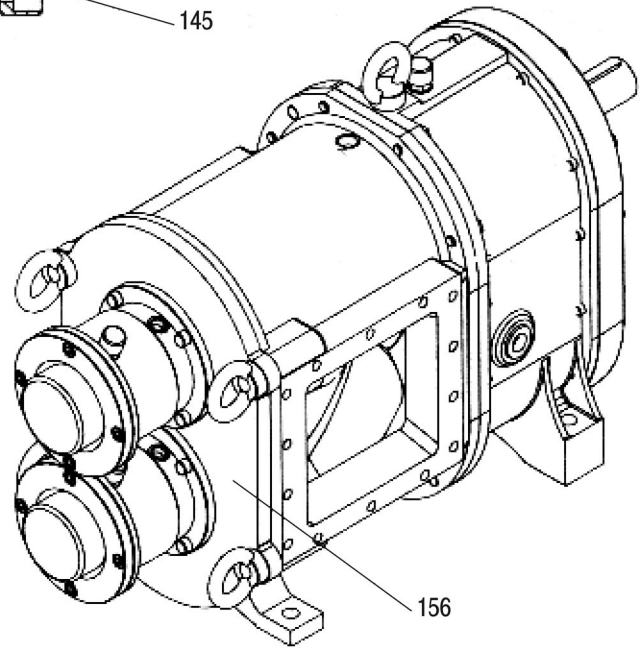
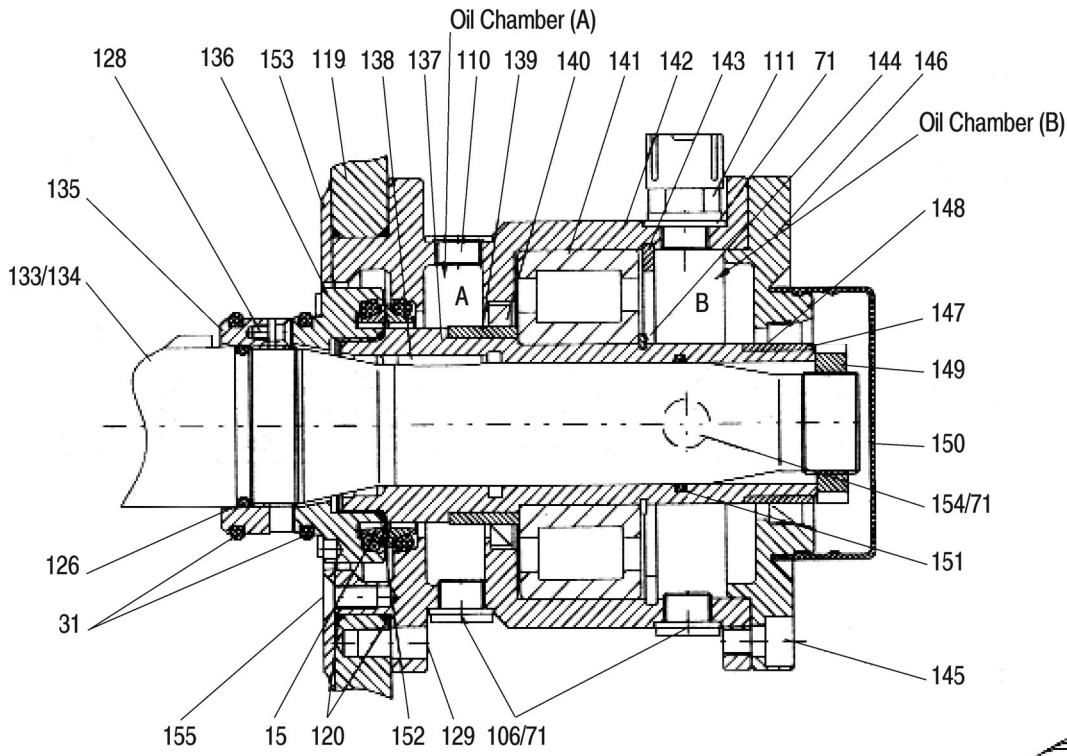

Drive Coupling Alignment Tolerances

This Rotoflo unit was aligned at the Factory, please observe the following parameters if the unit needs to be aligned:

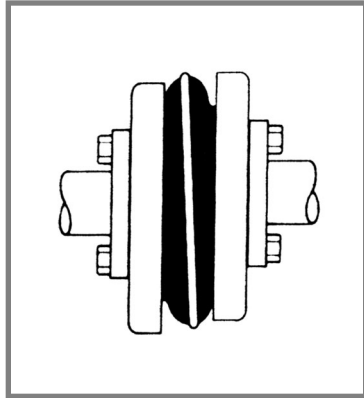

PARALLEL:

The S-Flex coupling accepts up to .032 in of parallel misalignment without wear. The flexible coupling sleeve minimizes the radial loads imposed on equipment bearings, a problem commonly associated with parallel misalignment.

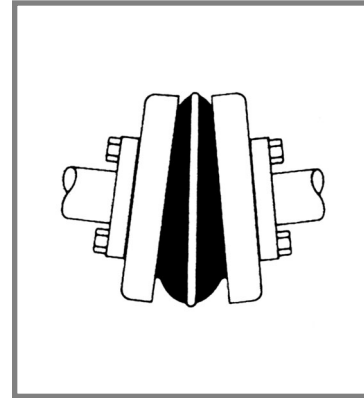

ANGULAR:

The flexing action of the elastomeric sleeve and the locking feature of the mating teeth allows the S-Flex coupling to effectively handle angular misalignment up to 1....

Notes



Moving Water Industries



MWI Corporate Headquarters

201 N. Federal Highway
Deerfield Beach, FL 33441
Phone: (954) 426-1500
Fax: (954) 426-1582

MWI Manufacturing Plant

33 N.W. 2nd. Street
Deerfield Beach, FL 33441
Phone: (954) 426-1505
Fax: (954) 426-8938

MWI Rental Division Headquarters

208 N.W. 1st. Street
Deerfield Beach, FL 33441
Phone: (954) 427-2206
Fax: (954) 426-2009

www.mwicorp.com