

ASI Model **DM-200 Series Diluting Module**

The ASI Model **DM-200 Series Gas Diluting Modules** have been developed to meet the requirements of some of our more specialized applications, where our standard in-situ dilution probe or a rather complex and expensive ex-situ (extractive) dilution system are simply not practical. Whether your primary diluting device is to be used as a stand-alone unit for laboratory applications, or integrated within an OEM's heated filter system design for CEM Systems (thereby producing a basic ex-situ diluting sampler), or even integrated into your ambient level gas analyzer for process monitoring, the **DM-200 is a great solution.**



Utilizing our High Efficiency **NZ²L** Mini-Eductor Pump (air driven aspirator), we have been able to maintain our standard of providing some of the lowest air consumption vs highest vacuum levels available in a mini-eductor. Why is this important? The higher flow orifices which are needed for low dilution ratios ask a lot of any gas diluting pump. When vacuum on the outlet of the orifice falls short, you ramp up the motive air pressure (to increase vacuum). In doing so however, you have increased your dilution air volume ... and subsequently your dilution ratio. This does not even consider the additional work that the pump must do when sampling from negative pressure sources, or

using long umbilical lines, etc. So, "piecing together" the garden-variety pumps and parts is not always the best approach ... it can quickly dump the budget (and a lot of dilution air), and still fall short. Instead, consider the **NZ²L** driven, **DM-200** Diluting Module.

Key Features:

- Compact and lightweight design
- Extremely low sample flow rates
- Wetted parts from SS-316/316L
- Normal dilution ratios from 12:1 up to 350:1
- Reduces the moisture content in the sample stream
- Reduces the maintenance and prolongs analyzer life when dealing with harsh samples
- Permits use of ambient level (low-range) analyzers to measure highly concentrated streams
- Can be used in hazardous areas; no steam or electrical service required (non-heated version)
- Complete with all fittings, mounting brackets, and critical orifice (Glass, Monel-400, SS-316)



- Special mounting provision material will allow for installation in your heated enclosure to ensure temperature stability as needed, and can be heated to well over 350°F (177°C). Our complete heated sampler (**DM-200HB**) is also available, ask for our separate DM-200HB sampler brochure.

- Special coatings by SilcoTek® (such as SilcoNert®, Dursan®, and Silcolloy®) are available for sample-path parts.
- Installation flexibility; Mounting brackets supplied as standard to allow for many mounting configurations. Installation of the diluter module within your rackmount controller enclosure, panel, drawer, or even inside your analyzer are much easier than with our previous DM-100 model.



OVERVIEW OF MODELS

GLASS ORIFICE DILUTION MODULE -A1.1

BASIC BRACKET MOUNTING AND PLACEMENT
"STACKED MOUNT" (PIGGY-BACK) CONFIG.

ASI MODEL #DM-200-A1.1

COMPLETE ASSEMBLY, BOTTOM PLATE OPTIONAL

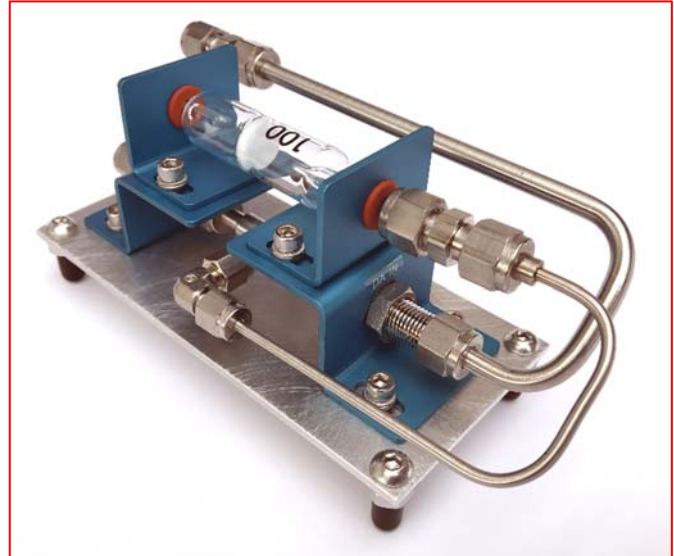
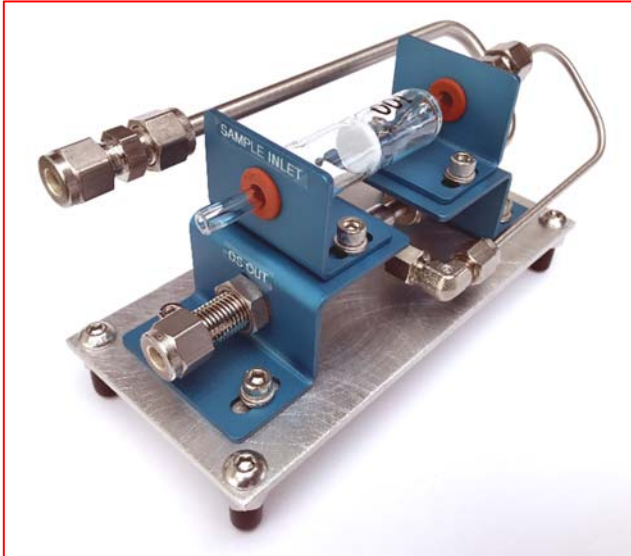

METAL ORIFICE DILUTION MODULE -B1.1

BASIC BRACKET MOUNTING AND PLACEMENT
"STACKED MOUNT" (PIGGY-BACK) CONFIG.

ASI MODEL #DM-200-B1.1

COMPLETE ASSEMBLY, BOTTOM PLATE OPTIONAL

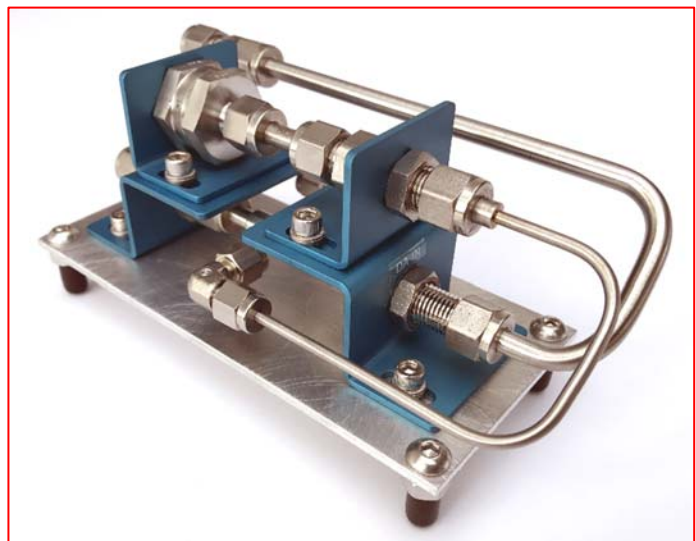
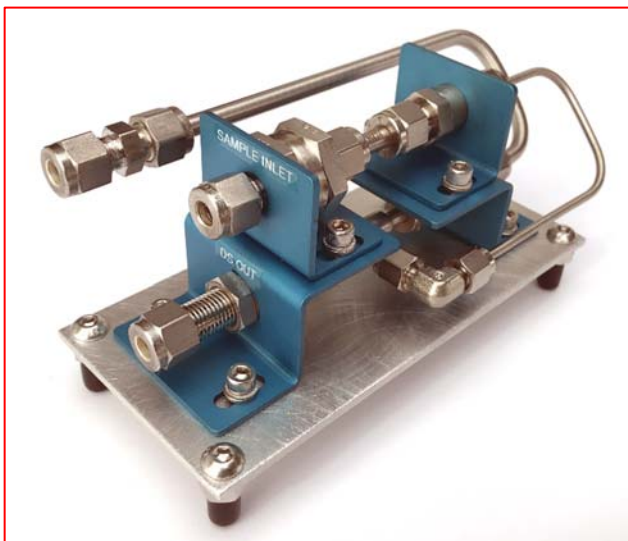



OVERVIEW OF MODELS (CONTINUED)

GLASS ORIFICE DILUTION MODULE -A2.1

BASIC BRACKET MOUNTING AND PLACEMENT
"FLAT MOUNT" (SIDE-BY-SIDE) CONFIG.

ASI MODEL #DM-200-A2.1

COMPLETE ASSEMBLY, BOTTOM PLATE OPTIONAL

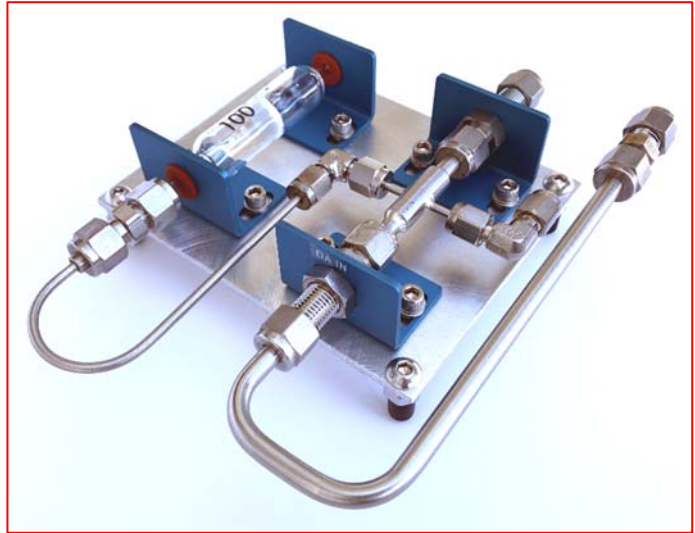
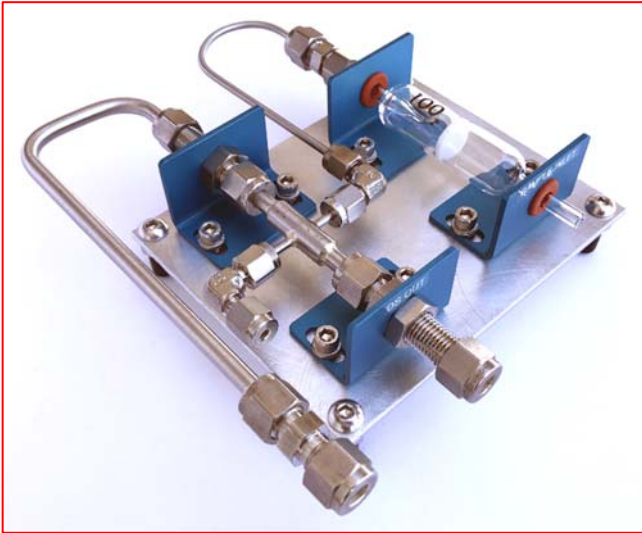

METAL ORIFICE DILUTION MODULE -B2.1

BASIC BRACKET MOUNTING AND PLACEMENT
"FLAT MOUNT" (SIDE-BY-SIDE) CONFIG.

ASI MODEL #DM-200-B2.1

COMPLETE ASSEMBLY, BOTTOM PLATE OPTIONAL

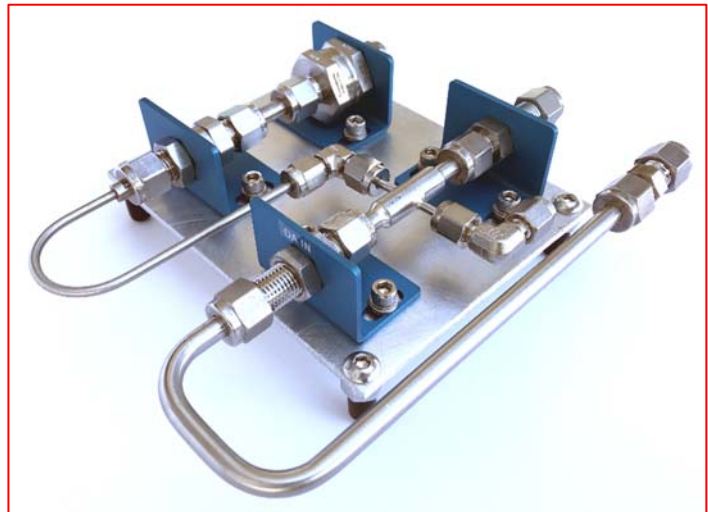
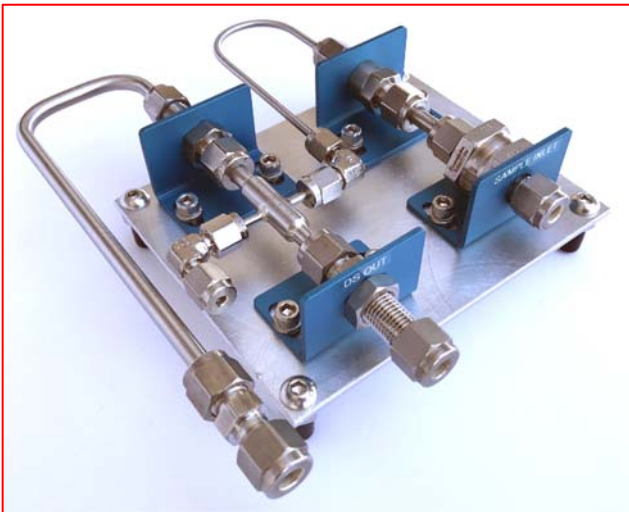



PRINCIPLE OF OPERATION

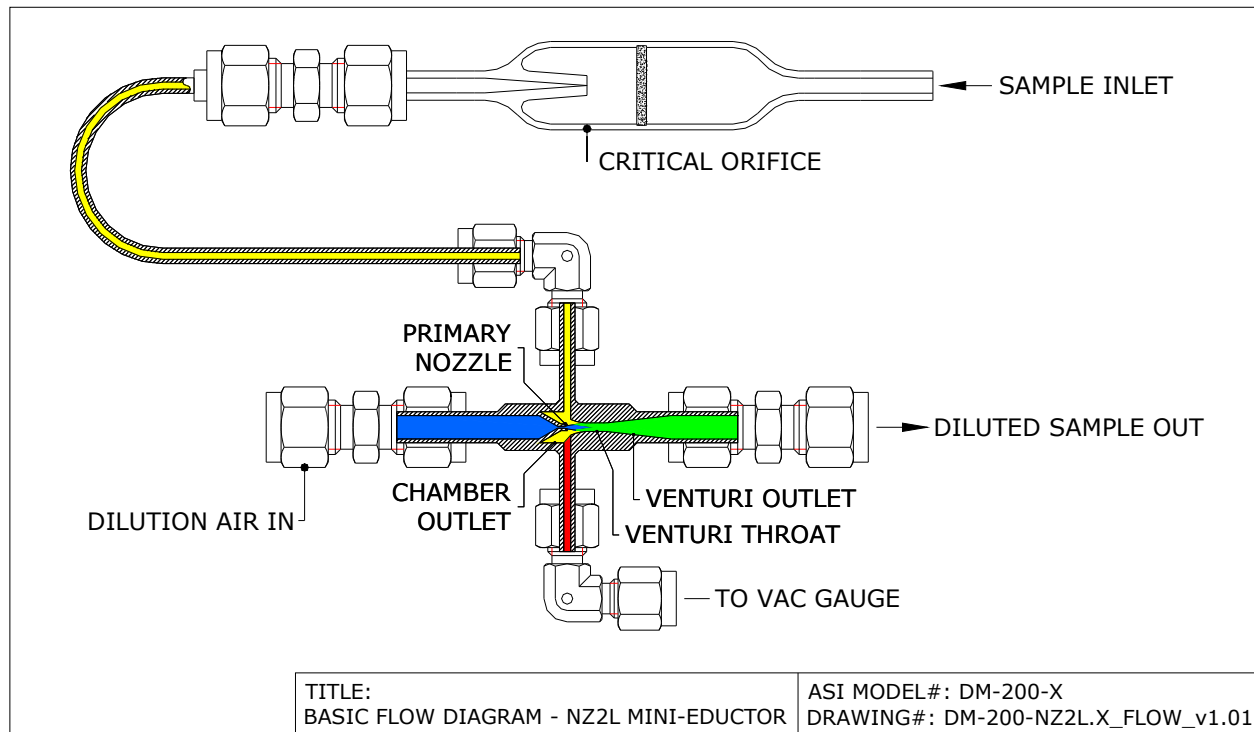

4 to 10 l/min (liters per minute) of clean, pressurized dilution air is transported to the diluting module via a tube in the umbilical cord (one of four tubes in the bundle). The dilution air is directed into the *dilution air-line*. Dilution air is then blown through the sharp *primary nozzle* of the ejector pump (air driven aspirator) into the *venturi throat* (from 2~6bar, 29~87psi). The flow of pressurized air through the nozzle creates a partial vacuum within the *chamber outlet*, which is also connected to the low-pressure end of the *critical orifice*. This vacuum, in turn, extracts a constant flow of sample from the *stack or process*, through the *critical orifice bore*, and to the *venturi outlet* where it is diluted and mixed with the clean, pressurized air. The *diluted sample* is then transported at positive pressure to the analyzer(s) via the unheated sample outlet line in the umbilical cord.

Note: Special considerations must be taken when the source gas is at a significant distance from the diluting module, as sample delay and response times may pose a challenge. A secondary high flow eductor (bypass pump) may need to be integrated into your sampling system design.

Theoretically, critical flow for air occurs when the ratio of the absolute pressure at the chamber outlet to the absolute pressure at the inlet (smoke stack, duct, or process) is less than or equal to 0.53. To maintain a constant flow rate through the critical orifice (and keep the orifice functioning within its critical range), the partial vacuum applied to the outlet of the orifice is kept at a gauge pressure below 0.47bar (13.87inHg). This vacuum is normally measured via a gauge located on the system's control panel, the connection to the diluter is made at the *vacuum line* which uses one of the four lines the umbilical cord.

Calibration gas can be supplied to the diluter via a separate line in the umbilical. This line can be connected (typically via a Swagelok® "T" fitting) at the *sample inlet* connection to the diluter. The volume of calibration gas is typically set to a minimum flow rate of 4x the critical orifice nominal flow rate, to ensure that the critical orifice has a sufficient inlet gas supply while providing an excess which is normally vented back to the sample source. The excess calibration gas ("bypass flow") will serve as a "gas barrier" to the process sample gas. This configuration assumes that the source pressure is atm or slightly negative. In positive source pressure applications, it may be necessary to construct a flow regulating path, to bring the sample flow down to the 2~4 l/min range. Again, a basic "T" fitting can be used. Flow regulation is done before the inlet to first port, second port to the diluting module's sample inlet line (upstream of the calibration "T" when applicable), and third port to vent the excess to atm. A separate line or port connection (independent of the calibration line) is also recommended to allow for monitoring of the sampling pressures, during both normal sampling and during calibration. This line connection should be located just upstream of the sample inlet of the diluting module. This will help to insure proper sample pressures and bypass flow.



CRITICAL ORIFICE (SONIC ORIFICE)

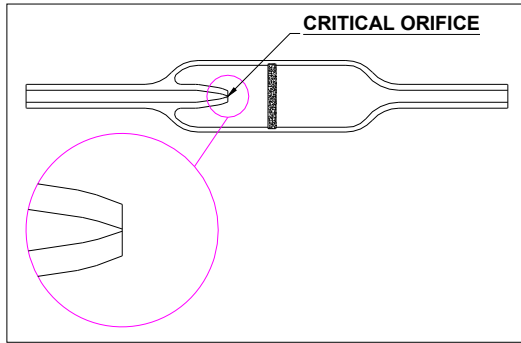

The critical orifice determines the flow rate at which sample is extracted from the source, as well as the ratio of dilution air volume to sample gas volume. It may be made from either standard glass (borosilicate) or special application metal (Monel® or Stainless-316) material, depending on various application parameters.

The glass orifice is connected to the pump section of the diluting module via stainless steel Swagelok® fittings and graphite ferrules (metal ferrules are not used). The metal orifice uses standard Swagelok® fittings with stainless steel ferrules. The front section (inlet end) of the orifice contains a fine/depth filter, consisting of ultra-pure quartz wool, as well as a fixed fritted disc. This filtering collects particulate and is exceptionally well-suited for trapping the gummy solids of moist gas streams and dry solids. Extreme care is taken during the packing of the filter to avoid channeling of the material.

Special attention has been paid to the geometry of the bore in the orifice. In this bore, the speed of the gas reaches the speed of sound (this type of critical orifice is also known as a sonic orifice). The factors influencing the flow through the orifice are expressed in the following equation:

where, G = Air flow through the bore in grams per second

- C = Constant
- O = Surface area of bore
- T = Temperature in degrees K
- P = Absolute pressure at bore inlet

$$G = \frac{C \cdot O \cdot P}{\sqrt{T}}$$

Theoretically, when the pressure at the bore outlet becomes less than 53% of the inlet pressure, further lowering the pressure at the outlet has no influence on the value of G. However, this theoretically defined constant of 0.53 is only valid for the use of a bore with infinite short length.

The actual constant depends on both the geometry of the bore and the nature of the gas, with values ranging between 0.2 and 0.8. Typically, glass capillaries have constants from 0.4 to 0.7 while hypodermic needles, in contrast, have much greater values (and therefore are not suitable for this type of application). Standard Dilution Ratios are noted in Table 2 (below):

| Average Dilution Range | Critical Orifice Nominal Flow Rate |
|------------------------|------------------------------------|
| 215:1 to 350:1 | 20 ml/minute |
| 95:1 to 150:1 | 50 ml/minute |
| 44:1 to 75:1 | 100 ml/minute |
| 32:1 to 50:1 | 150 ml/minute |
| 27:1 to 37:1 | 200 ml/minute |
| 20:1 to 30:1 | 250 ml/minute |
| 12:1 to 16:1 | 500 ml/minute |

Dilution Air into Diluting Aspirator: Q_1 ml/min
 Source Gas into Critical Orifice: Q_2 ml/min
 Diluted Sample to Analyzer: $Q_1 + Q_2$ ml/min

Dilution Ratio is $\frac{Q_1 + Q_2}{Q_2}$



SELECTING THE APPROPRIATE CRITICAL ORIFICE FLOW

The dilution ratio required by a CEM system is dependent on two factors:

- 1) The measurement range of the analyzer
- 2) The lowest ambient temperature possible

The dilution ratio required under the first of these factors is determined by simply dividing the maximum expected gas concentration (in the stack or process) by the maximum concentration the analyzer can measure. For example, if the maximum gas concentration in the stack is 560 ppm of SO₂ and it will be measured by an analyzer with a measurement range of 0 to 10 ppm, a dilution ratio of 56:1 (560/10) is required.

The second factor, the lowest ambient temperature possible, must be considered to ensure that no condensation will occur within the line carrying the diluted sample to the analyzer. The dilution ratio must be such that the moisture content of the diluted sample is reduced to a level below the dew point at the lowest expected ambient temperature. The required dilution ratio is calculated by dividing the water vapor concentration in the stack or process by the percent water vapor at the lowest expected temperature as shown in the Dew Point Table.

| Over Ice | | | | | Over Water | | | | |
|-------------|------|--|---------|------------------------------|-------------|-----|--|-------|------------------------------|
| Temperature | | H ₂ O = Saturation Vapor Pressure @ 101325 Pa | | % H ₂ O by Volume | Temperature | | H ₂ O = Saturation Vapor Pressure @ 101325 Pa | | % H ₂ O by Volume |
| °C | °F | Pa | mm Hg | | °C | °F | Pa | mm Hg | |
| -90 | -130 | 0.01 | 0.00007 | >0.001 | -15 | 5 | 191 | 1.44 | 0.189 |
| -80 | -112 | 0.05 | 0.0004 | >0.001 | -10 | 14 | 287 | 2.15 | 0.284 |
| -70 | -94 | 0.26 | 0.002 | >0.001 | -5 | 23 | 422 | 3.16 | 0.418 |
| -60 | -76 | 1 | 0.008 | 0.001 | 0 | 32 | 610 | 4.58 | 0.607 |
| -50 | -58 | 4 | 0.03 | 0.004 | 5 | 41 | 872 | 6.54 | 0.869 |
| -40 | -40 | 13 | 0.10 | 0.013 | 10 | 50 | 1228 | 9.21 | 1.227 |
| -35 | -31 | 23 | 0.17 | 0.022 | 15 | 59 | 1705 | 12.79 | 1.771 |
| -30 | -22 | 38 | 0.29 | 0.038 | 20 | 68 | 2338 | 17.54 | 2.363 |
| -25 | -13 | 63 | 0.48 | 0.062 | 25 | 77 | 3167 | 23.76 | 3.229 |
| -20 | -4 | 103 | 0.78 | 0.102 | 30 | 86 | 4243 | 31.82 | 4.375 |
| -15 | 5 | 165 | 1.24 | 0.163 | 35 | 95 | 5623 | 42.18 | 5.882 |
| -10 | 14 | 260 | 1.95 | 0.257 | 40 | 104 | 7376 | 55.32 | 7.862 |
| -5 | 23 | 402 | 3.01 | 0.398 | 45 | 113 | 9583 | 71.88 | 10.461 |
| -0 | 32 | 610 | 4.58 | 0.607 | 50 | 122 | 12333 | 92.51 | 13.884 |

760 mm Hg = 29.921 in Hg 1 mm Hg = 133.32 Pa = 1.3332 mbar 100 Pa = 1 mbar
 Source: CRC Handbook of Chemistry and Physics, 69th Edition. A Guide to the Measurement of Humidity, The Institute of Measurement and Control / National Physical Laboratory UK

For example, if the minimum ambient temperature is -10°C (14°F) and the source gas stream has a water vapor concentration of 20%, the dilution ratio required to prevent sample line condensation is 70:1 (20/0.284).

However, since both calculated dilution ratios must be satisfied (56:1 and 70:1), a critical orifice with the proper dilution range must be selected. As indicated in Table 2, which references performance data on the different critical orifices available from, this dilution range may be achieved by using a critical orifice with a nominal flow rate of 100 ml/min.

Determining the exact dilution ratio of the critical orifice under specific source gas conditions is commonly performed via dynamic calibration. The calibration gas is transported through the umbilical cord or dedicated line to the dilution module's sample inlet, diluted using the same ratio as the sample from the source gas, and then measured by the analyzer. Dividing the measured concentration by the actual concentration of the calibration gas (before dilution) yields an accurate value for the dilution ratio. For example, if the calibration gas has a concentration value of 560 ppm and the measured value at the analyzer is 9.5 ppm, then the dilution value is 0.016942 (560/9.5) or about a 59:1 dilution ratio. The actual dilution value can be used by a DAS (Data Acquisition System) to automatically convert analyzer readings to the source gas concentration values.



TEST & PERFORMANCE CERTIFICATE [EXAMPLE]

Date: 02/06/24

Customer: -

Cust. PO#: -

Dilution Instrument Model: DM-200-X

Serial Number: -

| Table 1 | Table 2 | Table 3 | |
|-----------------|--------------------|---------|-------|
| DA bar (psi) | Flow liters/min | -bar | inHg |
| 2.0 (29) | 4.0 | 0.54 | 15.95 |
| 2.5 (36) | 4.7 | 0.64 | 18.90 |
| 3.0 (44) | 5.4 | 0.69 | 20.38 |
| 3.5 (51) | 6.1 | 0.71 | 20.97 |
| 4.0 (58) | 6.9 | 0.72 | 21.26 |
| 4.5 (29) | 7.5 | 0.71 | 20.97 |
| 5.0 (73) | 8.3 | 0.69 | 20.38 |
| 5.5 (80) | 9.0 | 0.66 | 19.49 |
| 6.0 (87) | 9.6 | 0.62 | 18.31 |

Remarks:

INSTALL CRITICAL ORIFICE BEFORE ATTEMPTING TO USE

METAL ORIFICE DM WILL BE SUPPLIED "PRE-SWAGED" FROM ASI. WHEN INSTALLING METAL ORIFICE, TURN 1/4 FROM FINGER TIGHT. METAL ORIFICE DM VERSIONS MAY ALREADY HAVE ORIFICE INSTALLED PRIOR TO ORDER DISPATCH.

IF **GLASS TYPE CRITICAL ORIFICE DM** IS TO BE USED, BE SURE TO INSTALL 1/4" ID GRAPHITE FERRULE ON EACH END OF THE CRITICAL ORIFICE. STAINLESS STEEL FERRULES ARE NOT TO BE USED!!

GLASS ORIFICE DM NOTE: TIGHTEN NUT CONTAINING GRAPHITE FERRULE ONTO ORIFICE STEM, **BY HAND**, UNTIL FERRULE SNUG ONTO ORIFICE. BACK OUT THE ORIFICE BY ABOUT .04" (1mm) FROM UNION, THEN TIGHTEN NUT 1/2 TURN WITH WRENCH. IF FERRULE IS "RE-USED" (COMPRESSED) USE 1/4 TURN FROM FINGER TIGHT.

Test Procedure for Diluting Module Aspirator:

Pressurized air is supplied to the DA inlet of diluter (DA = Dilution Air). Pressure is set with RV to the values listed in Table 1. The air flow through the pump is measured with a mass flow meter, calibrated in liters/min. The measured flow is listed in Table 2. The partial vacuum generated by the aspirator is listed in Table 3. The connector for the critical orifice is capped off during this test which is performed at room temperature. Sample suction of the pump is zero during this test because of the stop plug.

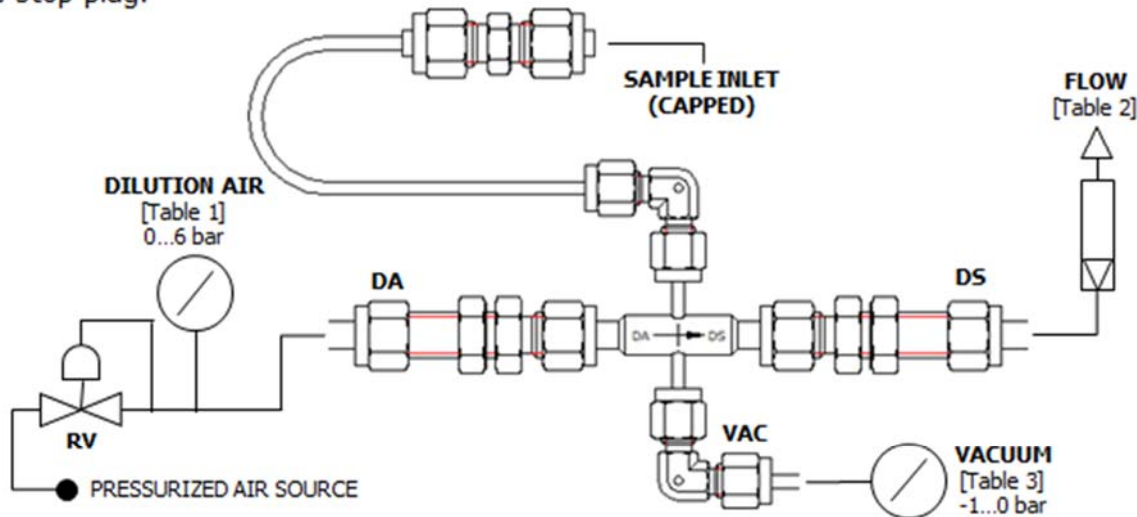

"DA" = DILUTION AIR LINE
 "DS" = DILUTED SAMPLE LINE
 "VAC" = VACUUM LINE
 "RV" = REDUCING VALVE (REGULATOR)

Pressure Conversions
 bar x 29.53 = inHg (inch of mercury (32° F))
 bar x 401.463 = inH₂O (inch of water (39.2° F))
 bar x 14.5038 = lbf/in² (pound force per square inch)



OPERATING TEMPERATURES

Although the **DM-200** has been designed and constructed with appropriate materials to allow the sample inlet temperature to exceed well over 350°F (177°C) we suggest that a short length of cool down tubing (typ. SS-316) be used to bring excessive inlet temperatures down to 350°F (177°C) or less.

When drawing sample into the DM-200, where external temperatures are cold enough (and sample moisture is high enough) to cause sample condensation before the dilution process, there may be a need to heat the source sample line until dilution can take place. Refer to the Dew Point Table to determine if the source sample needs to be transported via heated line.



Depending on the specifics of the application, there may be a need or desire to heat the diluting module itself (e.g.; due to anticipated ambient temperature swings or fluctuations, or gas composition which requires hot sample to avoid reactions, salt formations, etc.). The DM-200 can be integrated into your own heated enclosure to accomplish this, or you may consider our **DM-200H Heated Module**. Please contact us for further details.

INSTALLATION & APPLICATIONS NOTES

If the diluting module that ASI produces is to be used in other than small lab applications, or integrated into a CEMS analyzer shelter, there are a few points to consider before integrating the basic ASI diluting module. The diluting unit will, in some instances, may need to be built into some type of compact insulated enclosure. And to ensure temperature stability, some applications may benefit by heating the unit by some means. Further, if the diluting phase of the sample system is located some significant distance from the source gas (sample gas extraction point) you may need to have an additional pump (electric pump, or the more desirable air-driven eductor) to draw sample at a continuously higher volume to the dilution component to keep sample delay and response times within minimums if need be. Our more complete **DM-200HB Gas Sampler** may help with this.

There are other considerations as well, such as an inlet tube or pipe (heated or unheated). This would be used for the source gas sample transport path, from the source to the dilution component (diluting module). Possible coarse pre-filters at the sample extraction point, or at the tip of the extraction pipe or tube, may also be needed ... depending on the sample composition.

ASI does not currently offer a complete "turn-key system" (a dilution system complete with zero air generator, pneumatic controller, sample lines, or umbilical cord option, etc.), as our customers normally supply or construct these supporting components. Our stack testing customers are typically well equipped for this already, and utilize the standard "in-situ dilution probe" for most of our CEMS installations or RATA compliance setups. For specialized gas dilution sampling as well as mobile test vehicles, the DM-200 Module (or DM-200HB Heated/Portable Gas Sampler) is a great addition and integration is a relatively straight forward approach. Existing dilution probe controllers and umbilical cords are typically compatible. Please keep in mind that many of the components required to make it a complete "ex-situ" (extractive dilution) sampling system, still need to be designed and/or supplied by the customer or the integrator. These components may include; proper pneumatic controls and function gauges for the instrument (usually built into the instrument rack or panel at the analyzer location/shelter), sample lines as well as heated/unheated umbilical, etc.

Please note that ASI is happy to help with this planning by supplying our expertise and suggestions on what minimum panel controls and gauges should be used as standard, considerations for generating zero air (dilution air). We can also offer some basic design guidance if the ASI diluting module becomes your desired approach and you wish to develop it into a custom ex-situ or portable sample conditioner. Please let us know, and we can discuss your application requirements further.

When we utilize the dilution method for process monitoring, we want to make sure to have source sample gas at as close to ambient levels as possible, for the diluting device to sample from. Significant overpressure to the inlet of the critical orifice will cause errors in dilution ratio, with higher-than-expected flow rates through the critical orifice due to increased gas density. If positive pressure from the source is anticipated, a simple bypass stream can be constructed for the sample inlet to the diluter, and excess sample pressure vented to atm. For negative pressure applications; We must first know the anticipated application pressure. We then consider the orifice size to be used, distance from source gas extraction point - to the diluter, and if a secondary pump would be used to assist sample flow. We can then determine if the system can be operated without limitations.



SAMPLE DILUTER LOCATION - CONSIDERATIONS

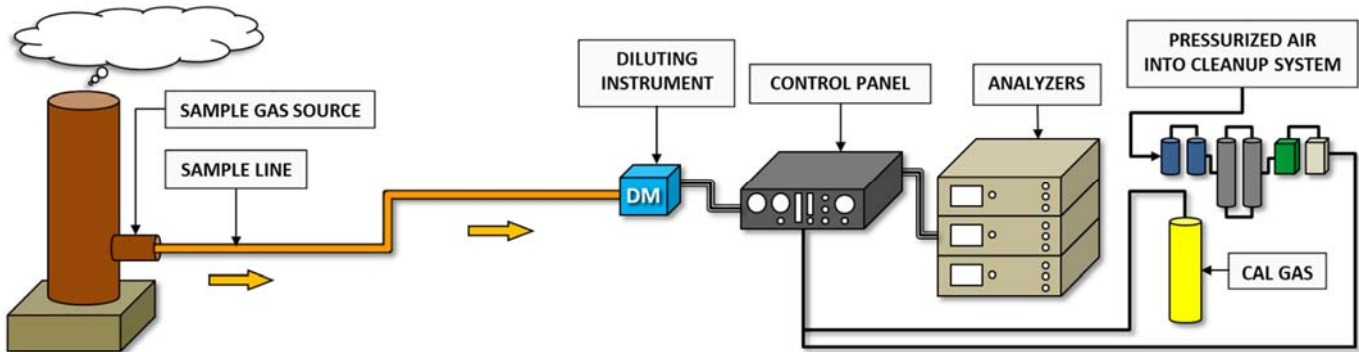

DILUTER IS SOME DISTANCE FROM SOURCE - BUT CLOSE TO CONTROLLER & ANALYZER:

PROS:

- 1) DILUTER IN TEMP-CONTROLLED SHELTER OR MOBILE VEHICLE MAY NOT REQUIRE HEATED ENCLOSURE.
- 2) SIMPLIFIED INTERCONNECTIONS WITH ANALYZER/S (BULKY UMBILICAL CORD NOT NEEDED).
- 3) CLOSE PROXIMITY TO CONTROLLER WILL FACILITATE SETUP, MAINTENANCE, AND TROUBLESHOOTING.

CONS:

- 1) SAMPLE DELAY AND RESPONSE TIMES MAY REQUIRE SECONDARY PUMP TO ASSIST SAMPLE FLOW.
- 2) MAY REQUIRE HEATED SAMPLE LINE TO THE DILUTER, DEPENDING ON MOISTURE AND TEMPERATURE.

NOTE: IF POSITIVE PRESSURE SOURCE, A SECONDARY PUMP MAY NOT BE NEEDED. A BYPASS CIRCUIT CAN BE UTILIZED AT THE DILUTING MODULE, WITH EXCESS SAMPLE VENTED TO ATM.

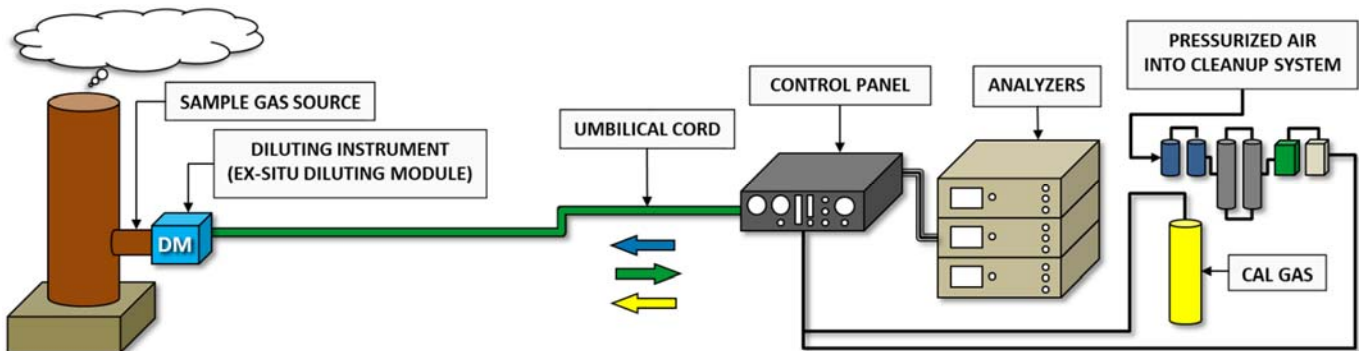

DILUTER IS LOCATED CLOSE TO SOURCE - BUT SOME DISTANCE FROM CONTROLLER & ANALYZER:

PROS:

- 1) SHORTER SAMPLE DELAY AND RESPONSE TIMES.
- 2) MAY NOT REQUIRE SECONDARY PUMP TO ASSIST SAMPLE FLOW TO THE DILUTER.
- 3) IF SAMPLE LINE TO THE DILUTER NEEDS TO BE HEATED, IT MAY BE OF MINIMAL LENGTH.
- 4) UMBILICAL CORD DOES NOT NEED TO BE HEATED AFTER DILUTER/DILUTION WITH PROPER DIL-RATIO.

CONS:

- 1) EXTERNALLY LOCATED DILUTER (IF PERMANENT, CONTINUOUS SAMPLING INSTALLATION) WILL LIKELY REQUIRE WEATHERPROOF ENCLOSURE. AS THE DM-200HB ENCLOSURE IS NOT NEMA/IP RATED.
- 2) NO STACK/DUCT PORT MOUNTING PROVISIONS AVAILABLE, AND NO SOURCE SAMPLE TUBE (STINGER).
- 3) MAY NOT BE IN CLOSE PROXIMITY TO CONTROLLER TO FACILITATE SETUP, MAINTENANCE, AND TROUBLESHOOTING.
- 4) REQUIRES UMBILICAL TUBE BUNDLE WITH ELCTRICAL AND T/C MESSENGER WIRES FOR HEATED ENCL.



**"STACKED" CONFIG.
(GLASS ORIFICE)**

MODEL DM-200-A1.1

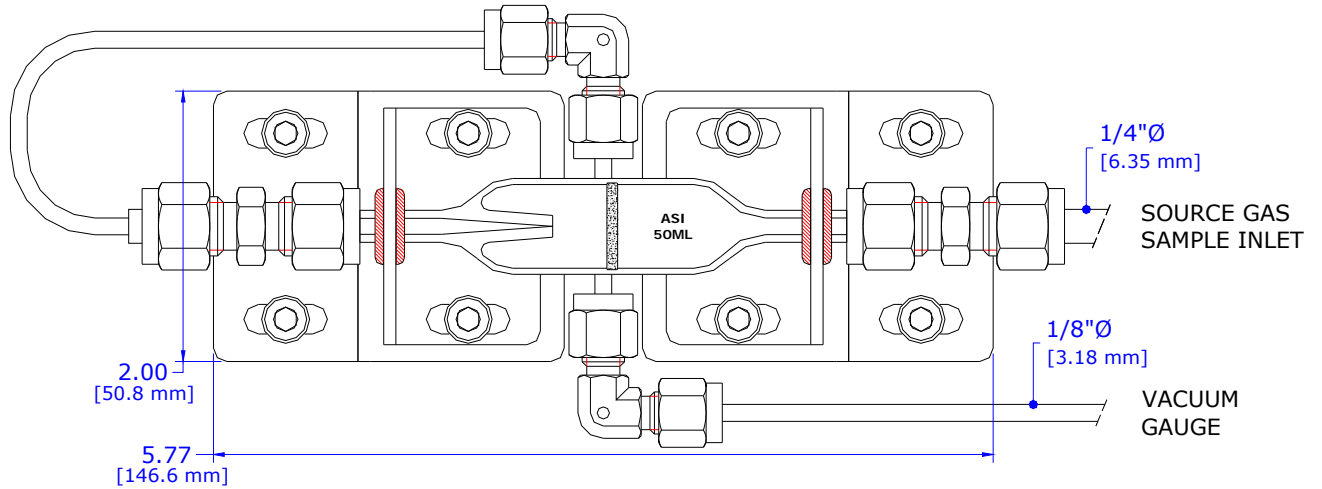

**"FLAT" CONFIG.
(GLASS ORIFICE)**

MODEL DM-200-A2.1

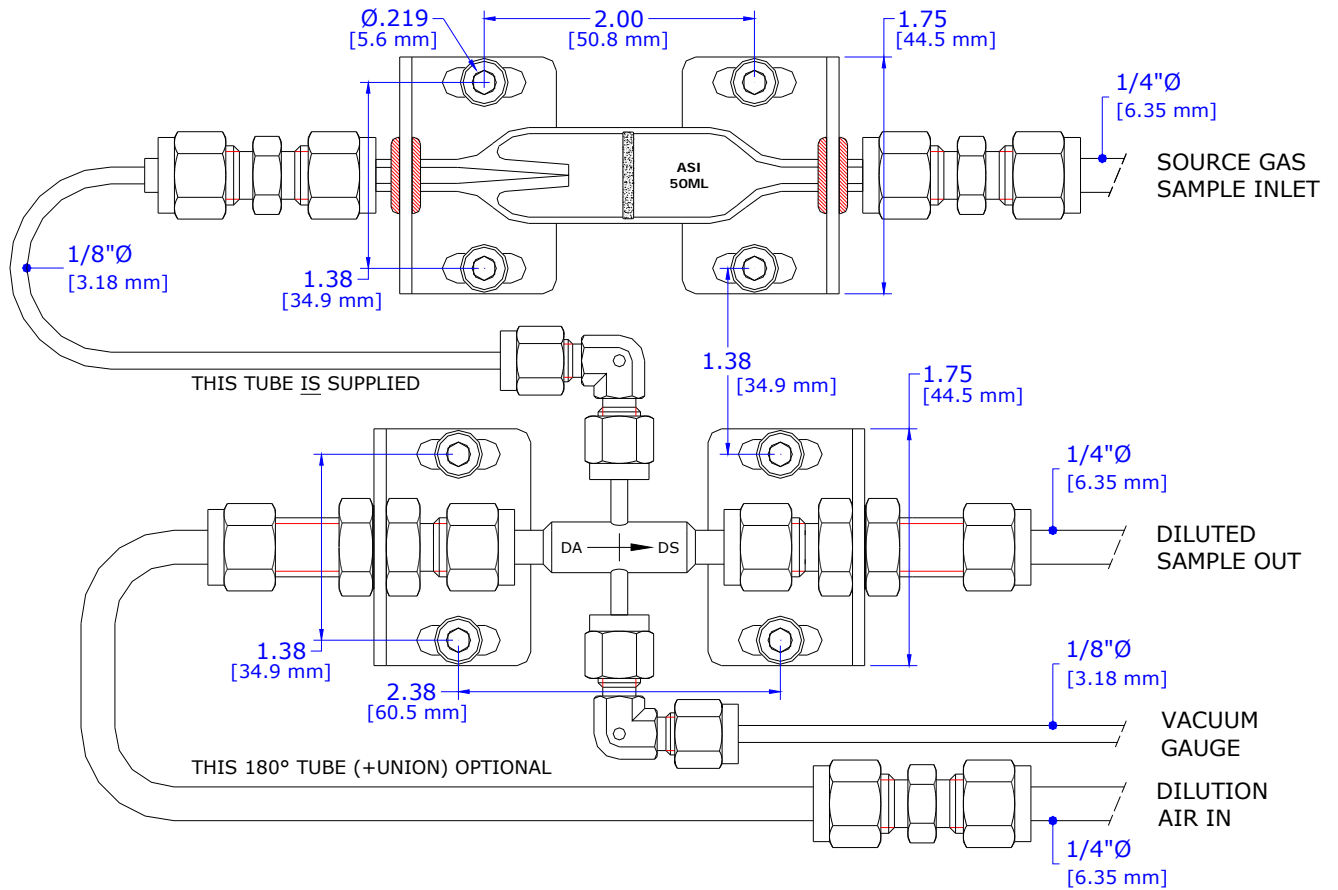

TITLE: DM-200 DILUTING MODULE
MOUNTING - "STACKED" VS "FLAT" (GLASS CO)

ASI MODEL#: DM-200-A1.1/-A2.1
DWG#: DM-200-CONFIGS-P1_v020624a



**"STACKED" CONFIG.
(METAL ORIFICE)**

MODEL DM-200-B1.1

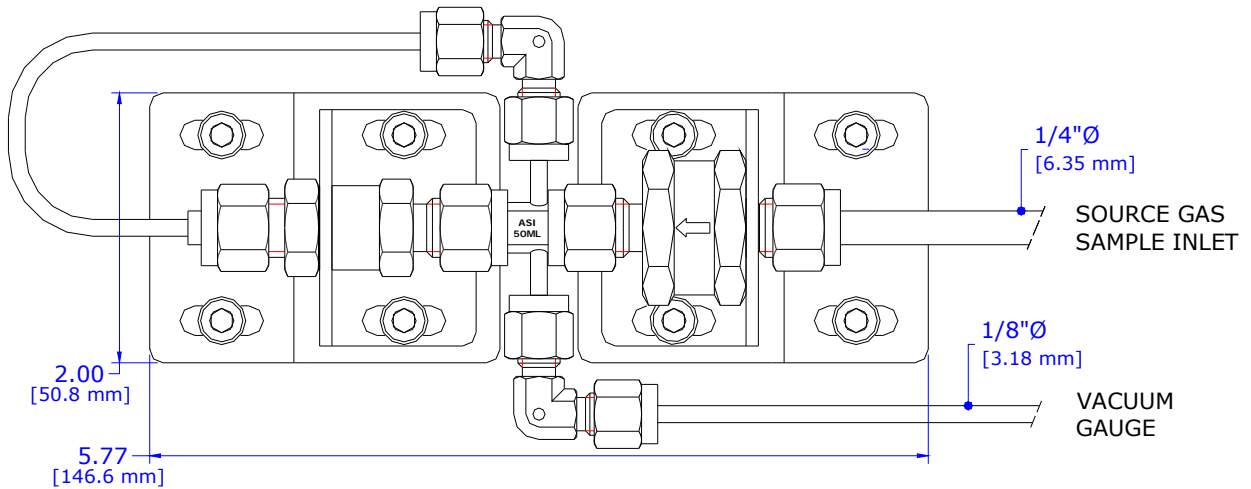

**"FLAT" CONFIG.
(METAL ORIFICE)**

MODEL DM-200-B2.1

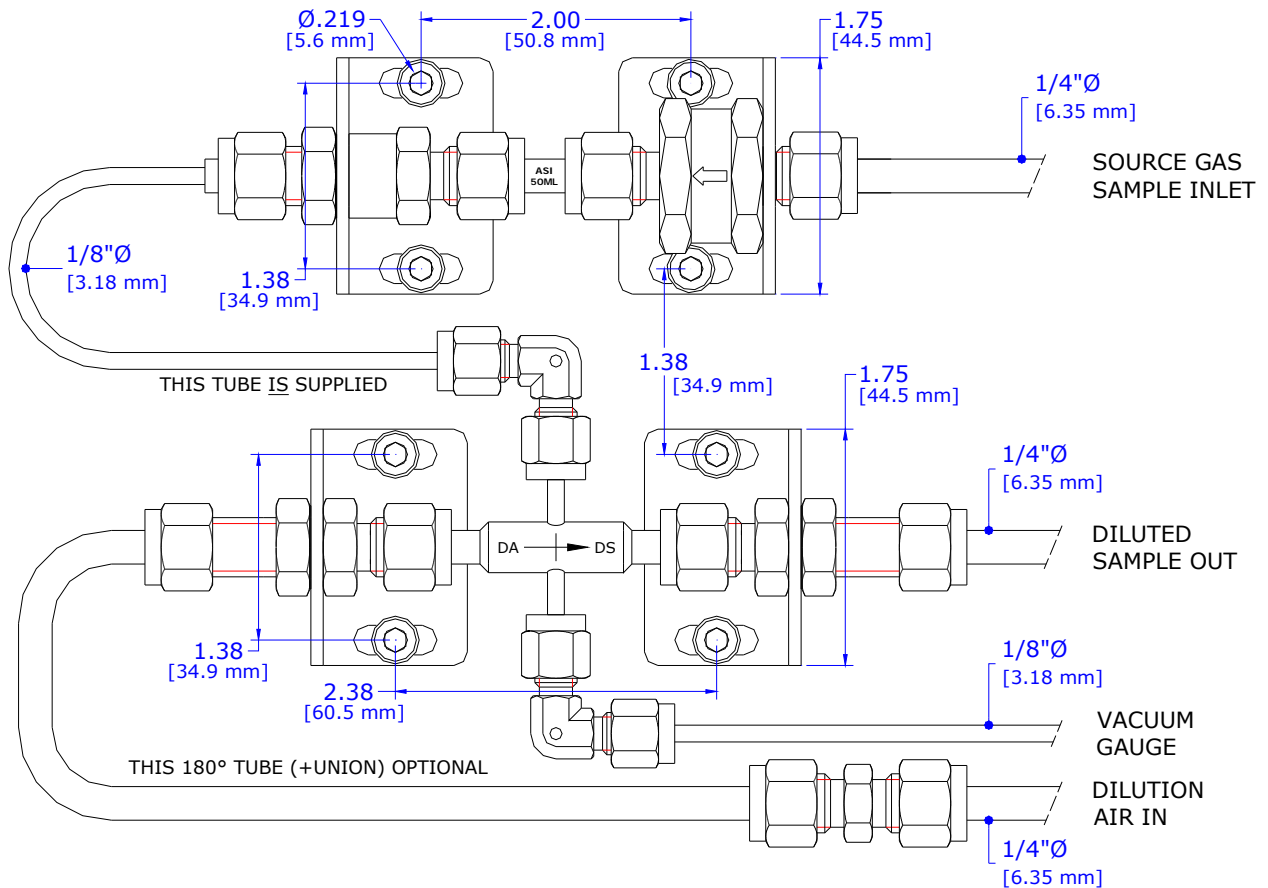

TITLE: DM-200 DILUTING MODULE
MOUNTING - "STACKED" VS "FLAT" (METAL CO)

ASI MODEL#: DM-200-B1.1/-B2.1
DWG#: DM-200-CONFIGS-P2_v020624a



**NOTE: THE CONTENT HEREIN IS PROPRIETARY INFORMATION
- PROPERTY OF ALPHA SUITE INC. -**

*THE INFORMATION AND COMPONENTS HEREIN ARE NOT TO BE DUPLICATED OR REPRODUCED
WHATSOEVER, WITHOUT PRIOR WRITTEN CONSENT FROM AN ALPHA SUITE INC. OFFICER.*

Alpha Suite Inc. is a USA based OEM which designs, develops, and supplies scientific instruments utilized in gas sampling and monitoring applications, mostly associated with process emissions. Specific instrumentation includes; [In-Situ Dilution Extractive Probes](#), [Ex-Situ Diluting Modules](#), [Probe Heaters](#), [Critical Orifices \(Sonic Orifices\)](#), [Related Instruments](#), [Spare Parts](#), [Maintenance and Repair Services](#). These instruments are most commonly used in Smoke Stack CEMS (Continuous Emissions Monitoring Systems), RATA or similar Test Audit Compliance, Process Monitoring, and specialized Laboratory Applications.



Please visit our website: www.alphasuite.com

*- For Instructional Purposes Only -
Specifications subject to change without notice
Contact Alpha Suite Inc. for current information
All Rights Reserved ©Alpha Suite Inc.*