

Request for Proposal (RFP)

Bid No: Bid 25-01-3563LE

Addendum No. 1

Date: February 28, 2025

To: All Proposers

Subject: Addendum No. 1
Consisting of Eighteen (18) Pages

RFP No.: Bid 25-01-3563LE

Project Name: N5001(1)1,2&4 Road Improvement Project in Toadlena/Two Grey Hills, NM

Owner: Navajo Division of Transportation

Proposer shall make note of and/or incorporate all changes listed below into the requested Request for Proposal (RFP):

1. Mandatory Pre-Proposal Meeting Minutes and Sign-In Sheet from February 19, 2025 meeting that was held at the Two Grey Hills Chapter House. Meeting minutes include responses to questions asked by attendees.
2. On Page 9 of the RFP, Part III, Section B. QUALIFICATIONS AND CAPABILITY, subsection e; replace the first sentence to read.
 - a. Document that each individual and/or firm that is proposing to perform material testing, general contracting and construction, and sub-contracting services, is properly licensed or registered to perform such services in the State of ~~New Mexico~~ **Arizona**.
3. Plans: Sheets 98-102 have been revised to clarify dimensions for Bridge N213 per question received. Replace plan sheets 98-102 and refer to the question-and-answer section.
4. Contract Book: Replace page 296 of Exhibit F with the attached page. Table 703-7 was revised.
5. The Navajo Division of Transportation has received the following question regarding this RFP and thereby issues the following response:

Request for Proposal (RFP)

Bid No: Bid 25-01-3563LE

Addendum No. 1

Question Submitted	Response Provided
Will Domestic Material be required for this project?	All materials are subject to Buy America requirements as outlined in Contract Book, Exhibit A, Article 6.3 and Exhibit C Special Contract Requirements, No. 3 “Buy America Requirements.”
What Entity or Agency is Funding this project?	The project funding source is the Federal Highway Administration (FHWA) Tribal Transportation (TTP) Program.
Could you provide the size for all pipe in inches and linear feet so as to make sure all prices are for the desired sizes?	No. Contractor is responsible to interpret all provided estimated project quantities in whichever units necessary to complete his/her construction bid.
Sheets 14-19 have marked out as “work removed from project scope”. Is the removal of these from this scope reflected in the bid form?	Yes, the quantities reflected in the bid schedule are estimated totals for construction in Unit I and Unit II. Sheets and quantity schedules that are marked “work removed from project scope” are not included in Unit I and Unit II.
Sheets 21-24 have marked out as “work removed from project scope”. Is the removal of these from this scope reflected in the bid form?	Yes, the quantities reflected in the bid schedule are estimated totals for construction in Unit I and Unit II. Sheets and quantity schedules that are marked “work removed from project scope” are not included in Unit I and Unit II.
Sec 602 Culvert and Drains references 707.02 for corrugated metal pipe culverts. Could you provide this spec?	Specification 707.02 is included in the FP-14 specification book that is provided via a link on Contract Book, Exhibit F cover page and below. https://flh.fhwa.dot.gov/resources/specs/fp-14/fp14.pdf
In doing so we have discovered the following concerns: Type b chipseal is ,if we are correct, 38.72 lbs per sy. Normally we apply chips at 22-25 lbs per sy. Type c chipseal comes out to 44.25 lbs per sy. Again we feel this is too heavy as we normally lay at 25-30 lbs per sy.	Please reference FP-14 Spec 407, Table 407-2, Type 2A for the proposed application rates of Aggregate, Asphalt Binder and Emulsified Asphalt. They are provided in both Metric and English units. The Government has reviewed these rates and suggest no revisions at this time. The Type 2A Thickness consists of a 3/4” nominal aggregate for the 1 st application and 3/8” nominal

Request for Proposal (RFP)

Bid No: Bid 25-01-3563LE

Addendum No. 1

<p>If we did our conversions correctly the over application of gravel by nearly double will create a lot more cost to the customer, as well as a lot more gravel that wont stick to the roadway and will be wasted to the side of the road.</p> <p>We request this quantity be reviewed and adjusted prior to bid day as the hauling and costs of this much gravel are significant.</p> <p>Emulsion crs 2p</p> <p>We feel the first application comes out to .46 gal per sy wich is correct, the second application appears to be heavy at .53 glallons per sy.</p> <p>Please verigffy this is the desired amount.</p> <p>The fogseal is set to be applied at .22 glllons per sy. We typically see a lighter rate of .15-.18 . Please verify rate is correct.</p> <p>Primecoat PEP our conversion of the quantities indicate a shot rate of .30 gallons per sy. This is extremely heavy. We normally see .10 to .20. Of course a lot of that depends on the soil porocity.</p> <p>Please verify the rate is correct.</p> <p>As the oil levels are estimated to be on the high side, we might suggest a line item for blotting sand by the Kilo.</p>	<p>aggregate for the 2nd application. The desired overall thickness for the double chip seal application is 7/8”.</p> <p>The Contractor shall utilize these application rates to determine his/her unit bid prices for the 40702-1100 Chip seal, type 2A bid item. Please reference Exhibit F, Supplemental Specification Section 407.14 (page 226 of Contract Book) for guidance on Measurement and Payment. No additional bid items will be considered for completion of the Chip Seal scope.</p> <p>During the review, it was determined that Table 703-7 on page 296 in Section 703.09 of Exhibit F, Supplemental Specification required revisions. Please reference the attached page 296 for the revised Table 703-7.</p> <p>Please note that the 41101-5000 Asphalt Prime Coat, Penetrating Emulsified Prime (PEP) bid item is a standalone bid item. The Government anticipates this work is needed to protect the completed/in-place aggregate base course layer upon its completion and prior to placement of the Chip Seal bid item. Should the Contractor and the CM determine that the Prime Coat is not required during construction, then this bid item may be deleted from the Contract. The final application rate for this work will be determined in the field between the Contractor and the CM.</p> <p>Once the bid proposals are submitted and a successful contract is executed, the Government is willing to review any Value Engineering Change Proposals (VECP) that the Contractor may feel is appropriate. Please reference Contract Book, Exhibit C, Special Contract Requirements, Clause NN-248-3: Value Engineering Construction for an explanation of the VECP process.</p>
<p>Will the department please verify the dimensions of the concrete leveling pad on structure 213. Plan sheet 99 is showing a width of 2.820 Meters. Additionally, the height of the leveling pad is referenced as</p>	<p>The depth of the leveling pad is to be 0.203m minimum to 0.500m maximum. The width of the leveling pad is to be 0.457m.</p>

Request for Proposal (RFP)
 Bid No: Bid 25-01-3563LE
 Addendum No. 1

.203 M on sheet 99 and on sheet 98 it is referenced as 500 MM max.	Plan sheets 98 thru 101 have been revised to reflect these dimension clarifications.
Will the department please provide a breakdown of the items that are to be paid for under bid item 20304-1000 (Removal of structures and Obstructions).	See the attached table of items that are to be included in Bid Item 20304-1000 Removal of Structures and Obstructions.
Note 8 (Removal of Existing Bridge) on plan sheet 93 of the project plans states that the contractor shall remove, clean and stockpile all existing salvageable material. Will the department please provide a list of the material that is to be salvaged for both bridges.	Contractor is not to salvage any of the bridge components. Contractor to remove and dispose of all existing bridge components. Please reference Plan Sheet 3, General Note 20 for additional direction on salvageable items.
Under Part III-Outline of Request of Proposal, Section B.-Qualifications And Capability, part "e" requires the firm that is providing the proposal to provide documentation showing they are properly licensed or registered in the State of AZ. This project is located in NM, does this requirement still apply?	No. Licenses and registrations for the State of Arizona are not required. This requirement should be New Mexico . The Request for Proposal language was corrected to reflect this clarification.
How will the geosynthetic in the integrated approach slab be paid for on plan sheet 102?	The geosynthetic in the integrated approach slab is to be paid under bid item number 57401-0000, GRS-IBS, Geosynthetic Reinforcement.
Will the department please clarify the dimensions for the integrated approach slabs. Section C-C on plan sheets 101 & 102 have different dimensions listed for the same drawing.	Integrated approach slab shall have 146 mm roadway aggregate over the GRS reinforcement. Plan sheets 101 & 102 have been revised to reflect this change.

END OF ADDENDUM NO. 1

Thank you for your interest!

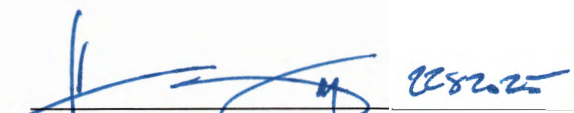

Ardaniel Begay, Principal Contract Analyst
 Project Contact Person



Navajo Division of Transportation
Bid No. 25-01-3563LE
N5001(1)1,2&4 Road Improvement Project in Toadlena/Two Grey Hills, NM
MANDATORY PRE-PROPOSAL MEETING
February 19, 2025, 10:00 am

The purpose of this Mandatory Pre-Proposal Meeting is to receive presentations on the Project Scope of Work and the necessary items required to be submitted as part of the Request for Proposal (RFP).

1. Introductions & Sign-In Sheet

- a. **Sign-In Sheet** – Please submit your contact information to Ardanuel Begay via email at abegay@navajodot.org

2. Welcome – Darryl Bradley, Principal Civil Engineer, Navajo DOT

3. General Announcements

- a. Information is available on the Navajo DOT website:
<https://navajodot.org/rfp%2Frfq>
- b. Inquiries on this RFP must be submitted in writing via fax or email to Ardanuel Begay, Principal Contract Analyst. The contact information is on page 2 of the RFP.
- c. Contractors are encouraged to conduct a field review of the project site on their own. There is no formal field review scheduled.

4. Schedule of Activities

- a. The Schedule of Activities is shown on page 3 of the RFP.
- b. Pre-Proposal Meeting today.
- c. Inquiry Timeline – all inquiries must be submitted in writing by 3:00 pm on February 25, 2025. Written responses to inquiries will be distributed through an Addendum by 10:00 am on February 28, 2025.
- d. Proposal due by 4:00 pm MDST on March 6, 2025.
- e. Opening Proposals and Evaluation – between March 10 and 14, 2025.
- f. Selection of Contractor – Week of March 17, 2025.
- g. Estimated Notice to Proceed Date – June 2, 2025.

5. Project Description & Scope of Work

- a. Project Plans, Roadway Cross-sections, Contract Book, NTUA Specs and Geotechnical Reports are available for download from the Navajo DOT website.
<https://navajodot.org/rfp%2Frfq>
- b. Funding Source is Federal Highway Administration (FHWA) Tribal Transportation Program.
- c. **Scope of Work consists of:** grading and roadway excavation; placement of aggregate base course and double chip seal pavement; installation of drainage structures, bridges (two total), precast concrete box culverts, fencing, cattleguards, gates, signs, striping, concrete barrier, guardrail, waterline and other miscellaneous work as called for in the design plans and specifications for this 4.481 km (2.78 mile) mile roadway project located in Toadlena/Two Grey Hills, NM, San Juan County, Navajo Nation.



Navajo Division of Transportation
Bid No. 25-01-3563LE
N5001(1)1,2&4 Road Improvement Project in Toadlena/Two Grey Hills, NM
MANDATORY PRE-PROPOSAL MEETING
February 19, 2025, 10:00 am

d. Completion Time – Per Article 4.3 of the NDOT Contract - Agreement.

The Work will be substantially completed within **240 working** days after the date when the Contract Times commence (Notice to Proceed) to run as provided in Paragraph 2.3 of the General Conditions and completed and ready for final acceptance in accordance with Paragraph 14.7 of the General Conditions within **260 working** days after the date when the Contract Time commence to run.

Please note that the above durations **do not** take into consideration non-working days for weather conditions, shutdowns during winter suspension(s) and holidays. See Article 12.3 of Standard General Conditions, Exhibit A for requirements related to Delay claims.

e. Bid Schedule – The Bid Schedule excel file has been provided as part of the bid documents.

- Contractor Quality Control - the normal “Contractor Quality Control” bid item has been removed from the bid schedule. Contractor will be responsible for developing a Quality Control Plan (QCP), determining the cost to complete his own quality control and then basing his bids on this effort. No separate measurement or payment of contractor quality control will be made. See Article 6.3.B – Services, Materials, and Equipment and Article 13.3.D – Tests and Inspections from Exhibit A of the Contract Book. See Section 153 – Contractor Quality Control of Exhibit F of the Contract Book.
 - The Government (NDOT) will be responsible for completing Independent Quality Assurance testing. See Section 153.01 of Exhibit F of the Contract Book.
 - A Contractor Furnished Field Testing Laboratory WILL NOT be required as part of this project.

f. Fuel Cost Adjustment – The contract language has been revised to include Fuel Cost Adjustment provisions. No adjustments will be made for fluctuations in the price of fuels other than diesel. See Section 109.06 of Exhibit F of the Contract Book.

g. Temporary Construction Easement – The project ROW maps include two TCEs. The duration of these TCE approvals is three years.

6. Coordination with BIA Navajo Region Branch of Transportation (NRBOT)

- a. Project was designed by Wilson & Company who will maintain the Engineer of Record responsibilities.
- b. BIA permits will be required to obtain access to the N5001 construction areas via BIA road ROW.
- c. All coordination with the BIA NRBOT will be conducted by NDOT and/or the designated project Construction Manager (CM).

7. Utility Coordination – See Article 7.1 of the NDOT Contract – Exhibit A - Standard General Conditions and Section 107.02 of the FP-14 Specifications.



Navajo Division of Transportation
Bid No. 25-01-3563LE
N5001(1)1,2&4 Road Improvement Project in Toadlena/Two Grey Hills, NM
MANDATORY PRE-PROPOSAL MEETING
February 19, 2025, 10:00 am

a. NTUA water – The new roadway construction requires that NTUA waterline crossings be lowered. The casing and waterline lowering to be completed by the Contractor with the associated bid items in the plans.

b. NTUA power – The new roadway construction requires that several NTUA overhead powerlines/poles be relocated by NTUA. This work will be completed by NTUA and will need to take place during construction.

c. Frontier communication – The new roadway construction requires that several Frontier overhead/underground lines and junction boxes be relocated by Frontier. This work will be completed by Frontier and will need to take place during construction.

8. Navajo Nation Business Regulatory Department

a. Navajo Business Opportunity Act & Source List

<https://navajoeconomy.org/business-regulatory/>

<https://navajoeconomy.org/business-regulatory/nboa-source-listing/>

<https://navajoeconomy.org/wp-content/uploads/2025/02/NBOA-Source-List-2025.02.4.pdf>

b. Subcontracting Plan

9. Review of Request for Proposal

a. Page 2 - proposals must be submitted to Navajo DOT at the address shown. Electronic proposals will not be accepted.

b. Page 5 - all work performed on this project is subject to the 6% Navajo Sales Tax.

c. Page 5 – evaluation procedure and criteria, including the scoring criteria.

d. Page 6 – the proposals will be opened and evaluated in accordance with the Navajo Nation Business Opportunity Act.

e. Pages 7 to 11 – Outline of Request for Proposal

f. Proposal must be submitted in a sealed envelope.

g. Bid Schedule must be submitted in a separate sealed envelope clearly marked as “Bid Schedule – RFP #25-01-3563LE Project N5001(1)1,2&4”.

An excel spreadsheet version of the Bid Schedule is included on the website.

h. Prime Contractor requirements – Self-Perform 50% of the work. See Special Contract Requirement, Clause NN-236-1.

i. Davis Bacon Wage Rates (Exhibit H of the Contract Book) apply for this Project. Make sure that you follow the appropriate wages for the county in which the project is located.

10. Addendum(s)

a. Addendum(s) will be available for download from the Navajo DOT website. It is important that respondents check the Navajo DOT website for addendum(s).

b. Addendum Acknowledgement Form



Navajo Division of Transportation
Bid No. 25-01-3563LE
N5001(1)1,2&4 Road Improvement Project in Toadlena/Two Grey Hills, NM
MANDATORY PRE-PROPOSAL MEETING
February 19, 2025, 10:00 am

11. Submitted Questions To Date:

- a. Buy America Requirements
- b. Conversions of quantities to customary are responsibility of the contractor
- c. Quantities in Bid Schedule reflect Unit I and Unit II work limits
- d. Link to FP-14 Specifications is provided on Exhibit F page of contract book
- e. Chip Seal & Tack/Prime Coat Application Rates

12. Items Discussed at the Meeting:

- a. It is the Contractor's responsibility for locating/designating a borrow source
- b. The utility relocations have not occurred yet. The Contractor will be responsible for the waterline lowering work as there are bid items to cover this. The power and communication lines are the responsibility of the utility owners, and they will be completing these relocations during the project. The Contractor will need to coordinate these relocations and afford for time in the schedule to complete them.
- c. A water source has not been identified. The Contractor is encouraged to contact the NN Water Resources

<https://nndwr.navajo-nsn.gov/>

<https://watercode.navajo-nsn.gov/>

Contact:

Jason John
Department Director
Ft. Defiance, AZ. 86504
(928) 729-4003

**N5001(1)1,2&4 Toadlena/Two Grey Hills, NM Road Project
Pre-Proposal Mtg. for RFP #25-01-3563LE
February 19, 2025 10:00 am Sign-In Sheet**



NAME / TITLE	COMPANY NAME	PHONE NUMBER / EMAIL
--------------	--------------	----------------------

Darryl Bradley, Principal Civil Engineer	Navajo Division of Transportation	505-371-8397 / dbradley@navajodot.org
Ardaniel Begay, Principal Contract Analyst	Navajo Division of Transportation	505-371-8351 / abegay@navajodot.org
Derek Meier, Sr Project Manager	Wilson & Company	505-400-4618 / derek.meier@wilsonco.com
Raymond M. Salazar, Construction Manager	Wilson & Company	505-504-4597 / raymond.salazar@wilsonco.com
Stephen Lujan, Project Manager	Wilson & Company	505-348-4169 / stephen.lujan@wilsonco.com
STEPHANIE BELAYE	WILSON & CO.	505 373 7869
MARVIN NOR	WILLMENG / PAUL JV	480 - 640 - 3579 / mnor@willmeng.com
PARKER BROWNELL	F.N.F. CONSP	505-239-2730 pbrownell@fnfinc.com
SHANE BENDER	AUI INC.	505-242-4848 julier@auinc.net
Courtney Hughes	GEOMAT	Courtney.hughes@geomatengineering.com
Saifur-Deen	GEOMAT ENG/TESTING	deen.iliass@geomatengineering.com
James Redhorse	Nusip Suro Creek Authority	505-210-7039 / james-redhorse@navajo.net
Patrick Wellsted	Granite Construction	520 349 5028 patrick.wellsted@grinc.com
Joseph Sedillo	Totsch Corp.	505 527 3234 totschcorporation@yahoo.com

N5001(1)1,2&4 Toadlena/Two Grey Hills, NM Road Project
Pre-Proposal Mtg. for RFP #25-01-3563LE
February 19, 2025 10:00 am Sign-In Sheet



NAME / TITLE	COMPANY NAME	PHONE NUMBER / EMAIL
--------------	--------------	----------------------

Calvin Hunt	attending meeting 2 GH	505-459-7231
David Curley	" " "	505 860-2979
GAYLE KNIGHT	VHCC VERNON HAMILTON CONSTR CO.	505-722-7855 gayle@vhccmaterial.com
Mark Solozar	Wilson Co.	505-504-4597 RMSOLZOR@WILSONCO.COM
Matthew Hadley	Arrow Indian Contractors	(918) 259-1626 m.hadley@arrowindian.com
Michael Redhorse	NECA	505 556 3781 michael@navajo.net
Jamie Sagg	NECA	(505) 543-9102 jamie@navajo.net
Brent Frye	Arrow Indian Contractors	214-982-1133 brent.frye@arrowindian.com
Lolita Spencer, ^{Secy/} Treasurer	Toadlena/Two Grey Hills Chapter	(505) 486-6005 lspencer@navajochapters.org
Leonarda Edndge, ^{TEH} Chapter Mgr	TTGH	(505) 789-3100 lelandgee@nchapters.org
Linda M. Johnson, C V-P	TDLA/TEH Chapter	(505) 512-7647 lmjohnson@naatacnci.org
CHRISTIAN HASSE	HASSE CONTRACTING	(505) 400-2336 CHASSE@HASSECO.COM
Emill T. Harley	NECA	(505) 210-7070 femill@navajo.net
STANLEY HARLEY	NECA	(505) 210-7026, stanleycharley@navajo.net

N5001(1)1,2&4 Toadlena/Two Grey Hills, NM Road Project
Pre-Proposal Mtg. for RFP #25-01-3563LE
February 19, 2025 10:00 am Sign-In Sheet



NAME / TITLE	COMPANY NAME	PHONE NUMBER / EMAIL
--------------	--------------	----------------------

Hunter Begaye	Black Mesa Fuels LLC	505 868 3525 / blackmesafuels1@gmail
Hubert Dayie	Black Mesa Fuel LLC	505 713 2195 / blackmesafuels1@gmail.com
Stanley Hardy	Toadlena / TGH ^{chapter} president	505 406 2703 shardy@ toadlena ^{navajochapters} .org
Angie Frank	Two Grey Hills	505.491.6665 a frank1415@gmail.com
Ray Smith	NECA	ray@navajo.net

REGION	STATE	RESERVATION	ROUTE	PROJECT NO.	SHEET	TOTAL SHEETS
NAVAJO	NEW MEXICO	NAVAJO	N5001	N5001(1)1,2&4	98	106

BEARING SEAT ELEVATIONS				
LOCATION	DESCRIPTION	LH EOD	CL Profile	RH EOD
ABUT. 1 CL BRG.	SLAB ELEV	1835.11	1835.18	1835.07
	SLAB TH	625	710.6	625
	SEAT ELEV	1834.49	1834.47	1834.50
LOCATION	DESCRIPTION	LH EOD	CL Profile	RH EOD
ABUT. 2 CL BRG.	SLAB ELEV	1834.97	1835.04	1834.93
	SLAB TH	625	710.6	625
	SEAT ELEV	1834.35	1834.32	1834.30

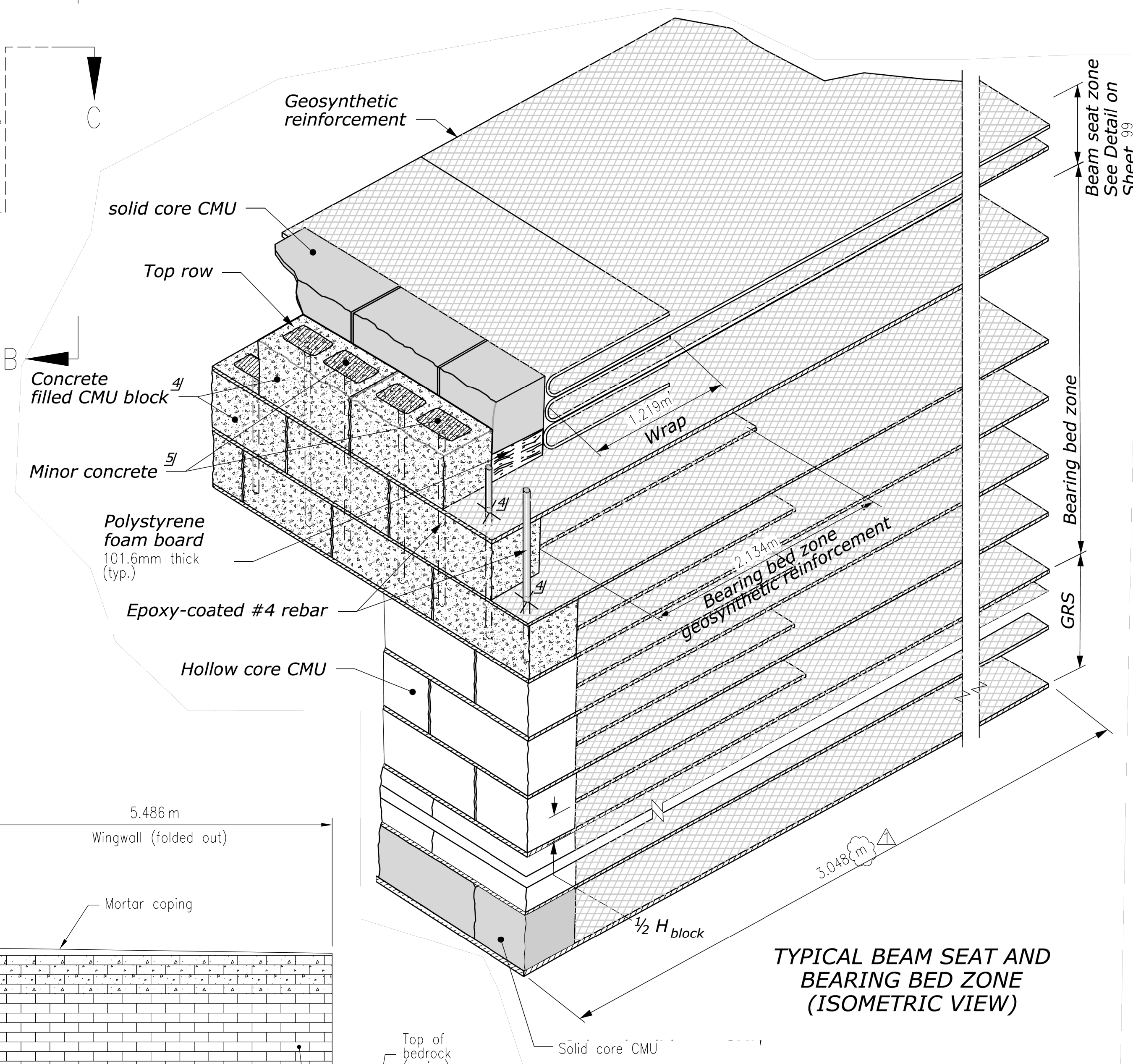
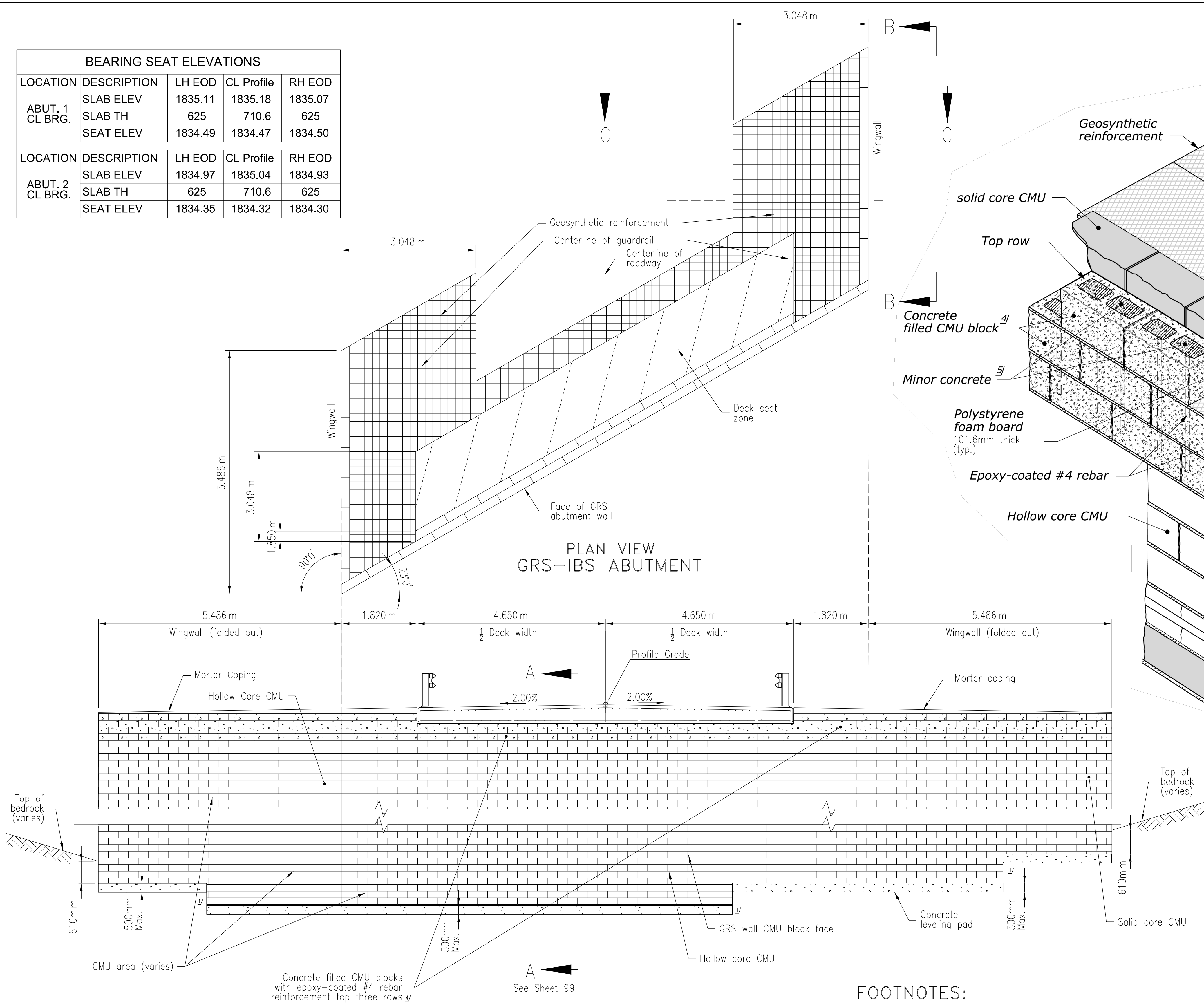

- NOTES:**
1. Insert epoxy-coated #4 rebars into the top 3 rows of CMU's and corner CMU's and fill with concrete.
 2. Stagger CMU blocks at 1/2 block width, including corners.
 3. On top row of CMU's create a mortar coping 25.4mm to 19.1mm sloped to face to drain.
 4. No colorant allowed in the hollow core concrete masonry units.

- FOOTNOTES:**
- 1/ Step as necessary to follow bedrock profile.
 - 2/ Wingwalls folded out for elevation view.
 - 3/ Colored solid core CMU's used behind riprap armor, to top of bedrock at wall face, and at the beam seat zone. (Riprap armor not shown.)
 - 4/ Cut "X" into bottom geosynthetic reinforcement of upper 2 courses of CMU blocks to accept rebar and concrete.
 - 5/ Wet cast mortar coping not shown.
 - 6/ GRS-IBS North Abutment Integrated Approach illustrated in Section A-A and C-C on Sheet 102.

- Minor concrete
- Hollow core concrete masonry unit (CMU)
- Solid core concrete masonry unit (CMU)
- Concrete filled hollow core concrete masonry unit (CMU)

**ELEVATION VIEW 1/2
GRS-IBS SOUTH ABUTMENT 1/2
FACING BLOCK SCHEDULE 1/2**

**NAVAJO DIVISION
OF TRANSPORTATION**

**GRS-IBS
PLAN AND ELEVATION**

DRAWN BY: WCI	DATE: 04/19
DESIGNED BY: KRH	DATE: 04/19
REVISED: 02/25	BY: GMG

1	ADDENDUM #1	GMG	2/28/25
△	REVISION	BY	DATE



2/27/2025 12:22:07 PM N213_GRS-IBS_DTL_1a.dgn

REGION	STATE	RESERVATION	ROUTE	PROJECT NO.	SHEET	TOTAL SHEETS
NAVAJO	NEW MEXICO	NAVAJO	N5001	N5001(1)1,2&4	99	106

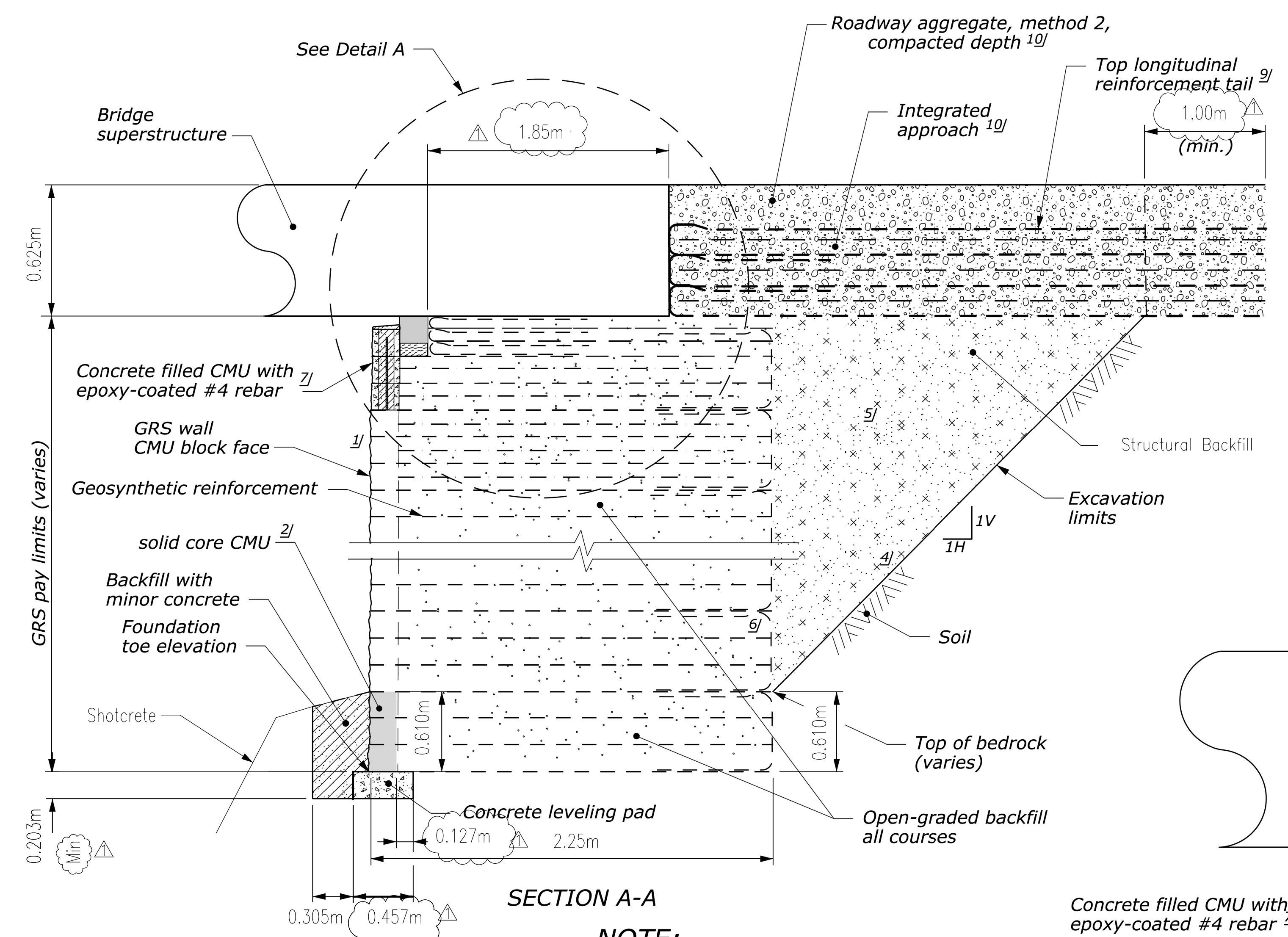

SECTION A-A

- NOTE:**
1. Insert epoxy-coated #4 rebars into the top 3 rows of CMU's and corner CMU's and fill with concrete.
 2. On the top row of CMU's create a mortar coping 25.4mm to 19.1mm sloped toward face to drain.
 3. Strike CMU concrete fill flush with top of CMU's under bridge deck.
 4. No colorant allowed in the hollow core concrete masonry units.

- FOOTNOTE:**
- 1 Vertical wall face batter = 0°.
 - 2 Colored solid core CMU's to top of bedrock at wall face.
 - 3 Minimum of 5 layers of bearing bed reinforcement.
 - 4 Short term back slope ratio per OSHA Safety Regulations (29CFR, Part 1926, Subpart P, excavation). Shoring may be required if the short term back slope will be open more than 30 days or if the required short term back slope ratio specified cannot be obtained.
 - 5 Backfill and compact simultaneous to GRS-IBS construction.
 - 6 Wrap ends of geosynthetic reinforcement minimum of 1.000m every third layer (max.).
 - 7 Cut "X" into bottom geosynthetic reinforcement of upper 2 courses of CMU blocks to accept rebar and concrete.
 - 8 Clear space between bottom of bridge superstructure and top of mortar coping varies with superelevation, min. 76.2mm.
 - 9 Extend top layer wrapped tail longitudinally for the full length of the integrated approach.
 - 10 GRS-IBS North Abutment Integrated Approach illustrated in Section A-A' and C'-C' on Sheet 102.

LEGEND:

	Open-graded backfill
	Roadway aggregate
	Minor concrete
	Structural Backfill
	Hollow core concrete masonry unit (CMU)
	Solid core concrete masonry unit (CMU)
	Concrete filled hollow core concrete masonry unit (CMU)

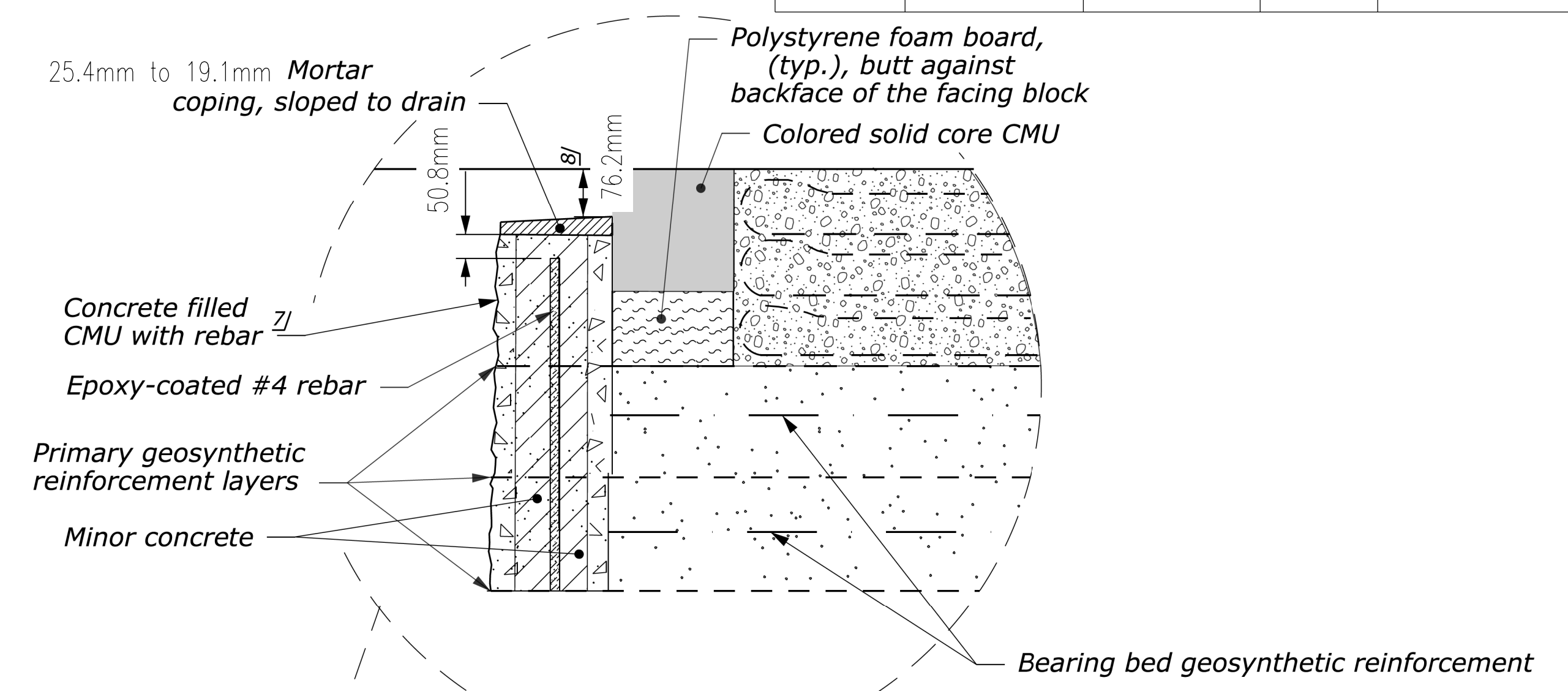

DETAIL A
(GRS, beam seat, bearing bed zone, and integrated approach detail)
NO SCALE

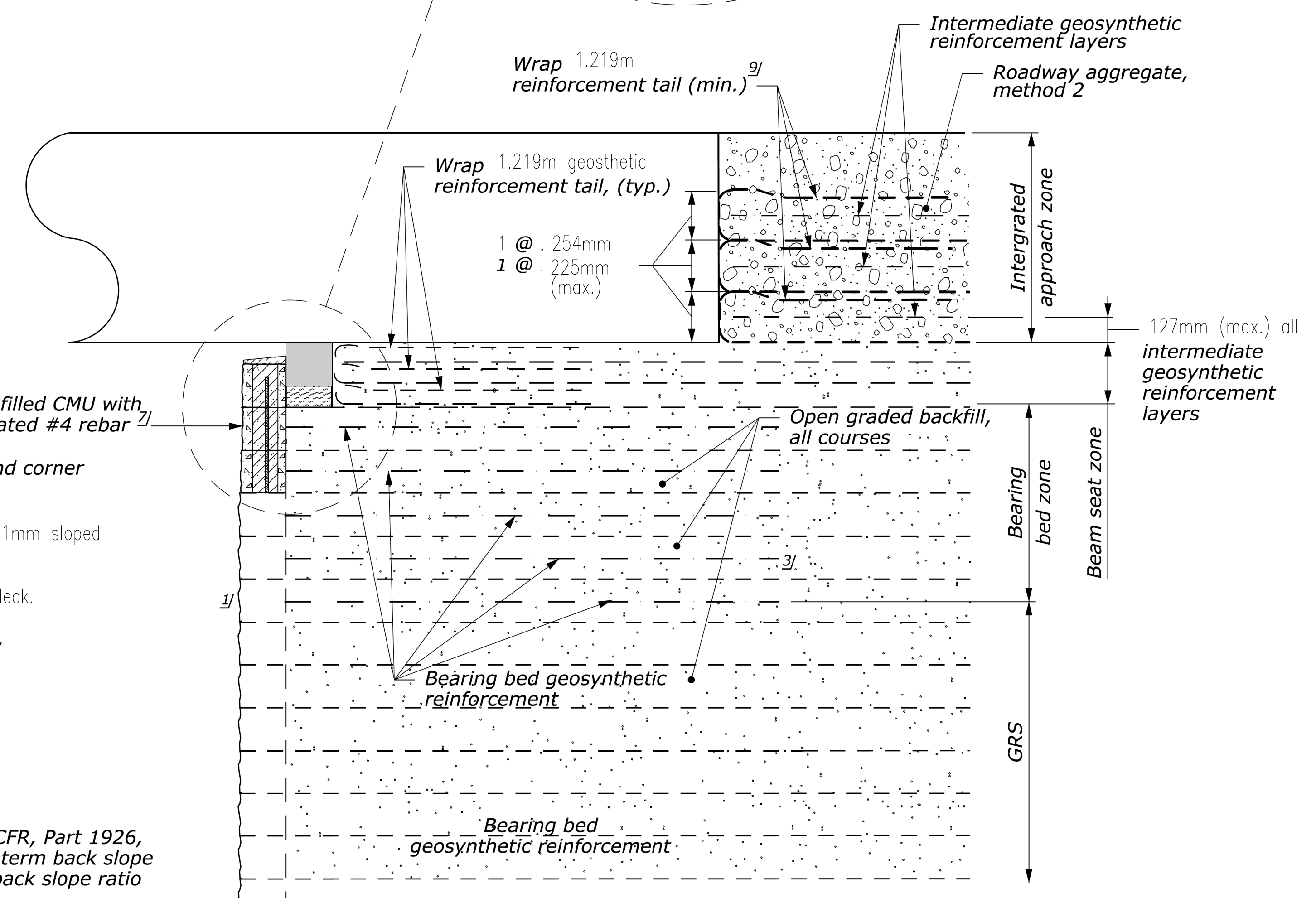

NAVAJO DIVISION
OF TRANSPORTATION

GRS-IBS-DETAIL
SHEET 1 OF 4

DRAWN BY: WCI	DATE: 04/19
DESIGNED BY: KRH	DATE: 04/19
REVISED: 02/25	BY: GMG

N213_GRS_IBS_DTL_1.dgn

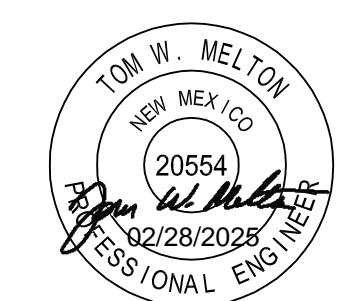

1	ADDENDUM #1	GMG	2/28/25
△	REVISION	BY	DATE



N213_GRS_IBS_DTL_1.dgn 2/27/2025 1:01:55 PM

REGION	STATE	RESERVATION	ROUTE	PROJECT NO.	SHEET	TOTAL SHEETS
NAVAJO	NEW MEXICO	NAVAJO	N5001	N5001(1)1,2&4	100	106

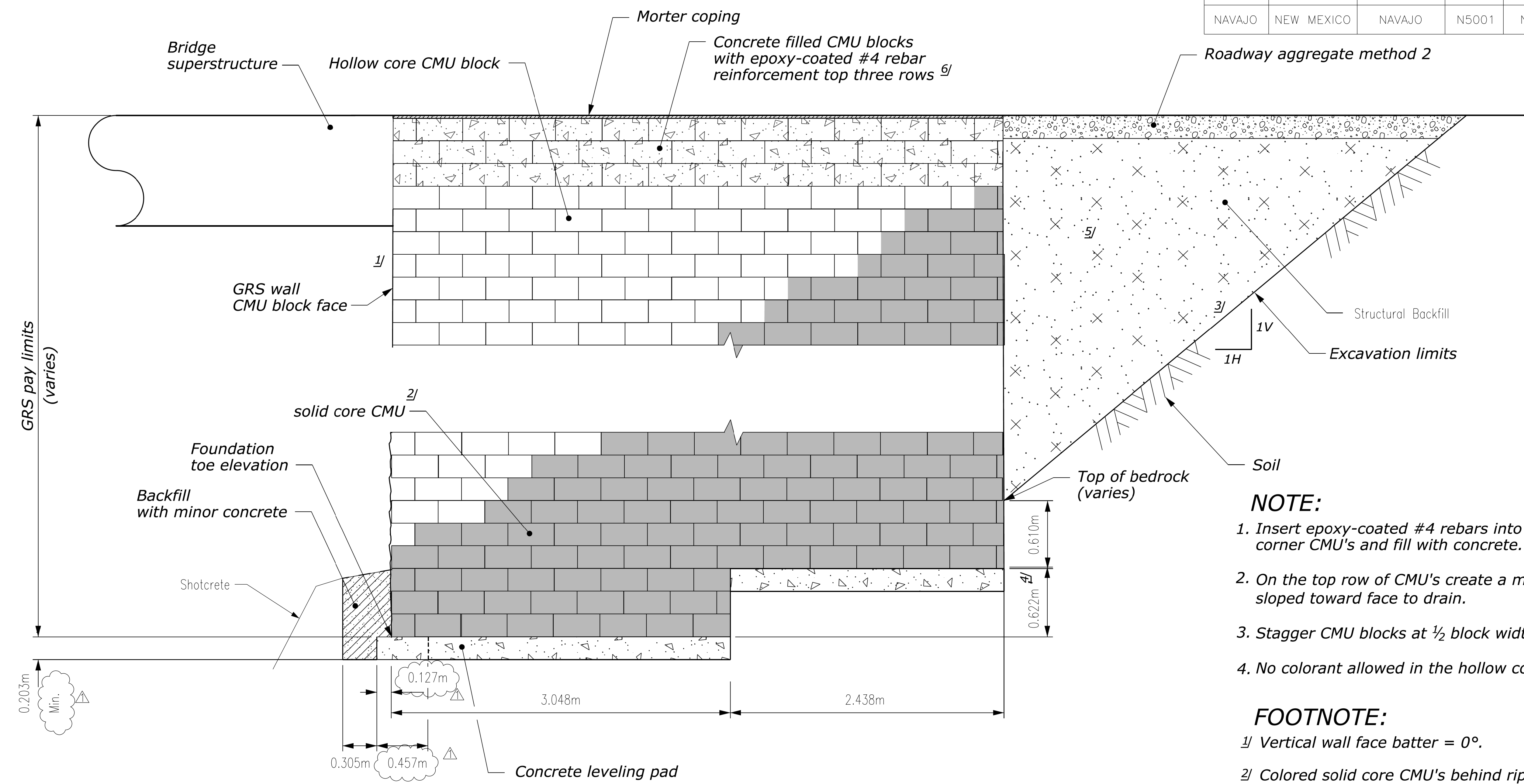

WINGWALL ELEVATION
VIEW B-B







NOTE:

1. Insert epoxy-coated #4 rebars into the top 3 rows of CMU's and corner CMU's and fill with concrete.
2. On the top row of CMU's create a mortar coping 25.4mm to 19.1mm sloped toward face to drain.
3. Stagger CMU blocks at 1/2 block width, including corners.
4. No colorant allowed in the hollow core concrete masonry units.

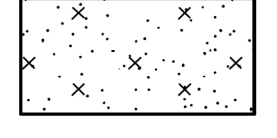
FOOTNOTE:

- 1/ Vertical wall face batter = 0°.
- 2/ Colored solid core CMU's behind riprap. (Riprap not shown.)
- 3/ Short term back slope ratio per OSHA Safety Regulations (29CFR, Part 1926, Subpart P, excavation). Shoring may be required if the short term back slope will be open more than 30 days or if the required short term back slope ratio specified cannot be obtained.
- 4/ Step GRS-IBS to follow bedrock profile when encountered.
- 5/ Backfill and compact simultaneous to GRS-IBS construction.
- 6/ Cut "X" into bottom geosynthetic reinforcement of upper 2 courses of CMU blocks to accept rebar and concrete.

LEGEND:

-  Structural Backfill
-  Roadway aggregate
-  Minor concrete
-  Hollow core concrete masonry unit (CMU)
-  Solid core concrete masonry unit (CMU)
-  Concrete filled hollow core concrete masonry unit (CMU)

NAVAJO DIVISION
OF TRANSPORTATION

GRS-IBS-DETAILS
SHEET 2 OF 4

DRAWN BY: WCI	DATE: 04/19
DESIGNED BY: KRH	DATE: 04/19
REVISED: 02/25	BY: GMG

N213_GRS_IBS_DTL_2.dgn

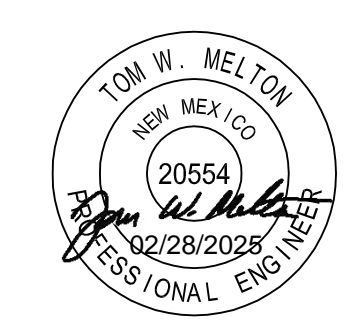

1	ADDENDUM #1	GMG	2/28/25
△	REVISION	BY	DATE



N213_GRS_IBS_DTL_2.dgn 2/27/2025 1:21:46 PM

REGION	STATE	RESERVATION	ROUTE	PROJECT NO.	SHEET	TOTAL SHEETS
NAVAJO	NEW MEXICO	NAVAJO	N5001	N5001(1)1,2&4	101	106

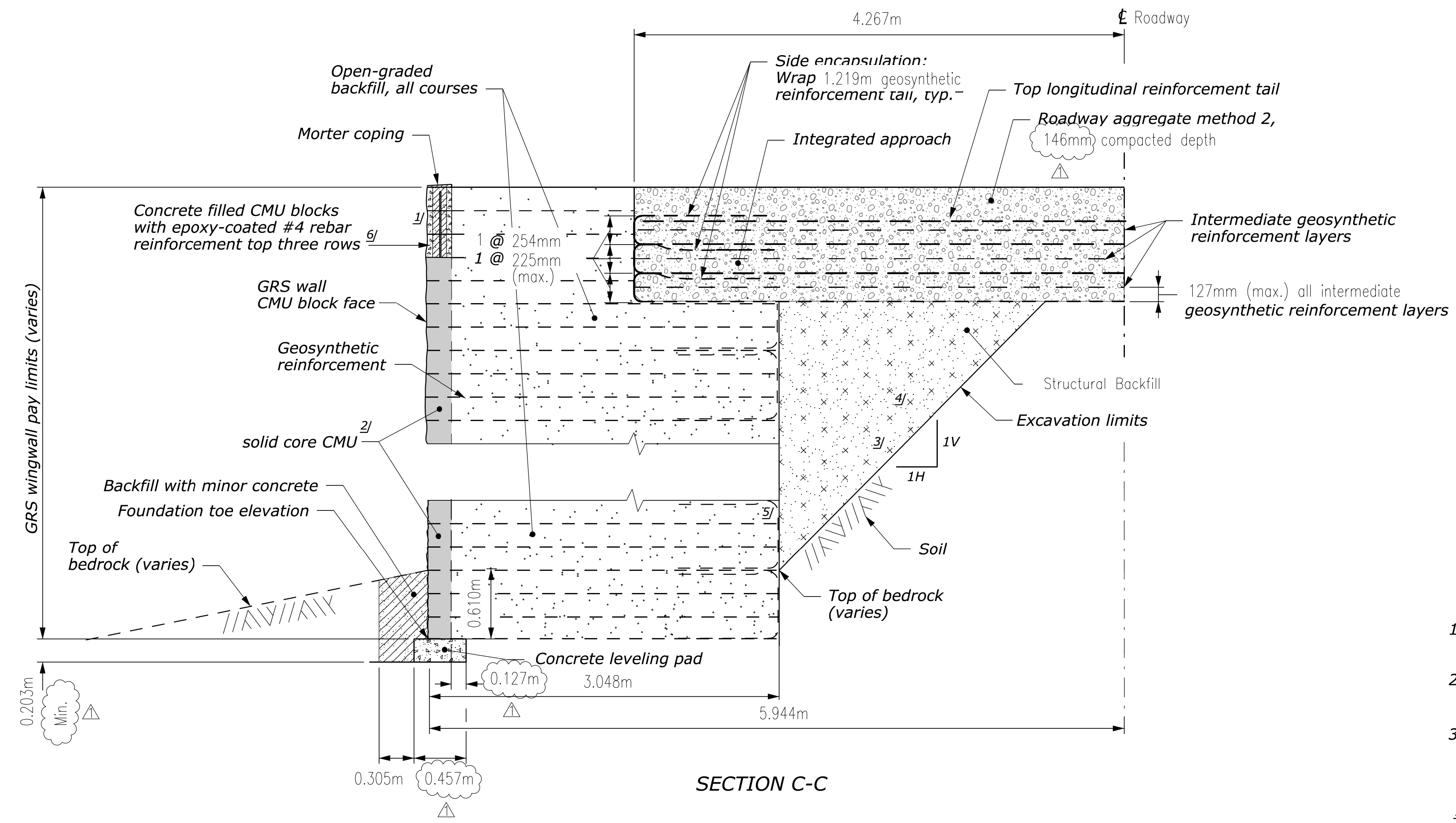

- NOTE:**
1. Insert epoxy-coated #4 rebars into the top 3 rows of CMU's and corner CMU's and fill with concrete.
 2. On the top row of CMU's create a mortar coping 25.4mm to 19.1mm sloped toward face to drain.
 3. No colorant allowed in the hollow core concrete masonry units.

- FOOTNOTE:**
- 1/ Vertical wall face batter = 0°.
 - 2/ Colored solid CMU's behind riprap armor.
 - 3/ Short term back slope ratio per OSHA Safety Regulations (29CFR, Part 1926, Subpart P, excavation). Shoring may be required if the short term back slope will be open more than 30 days or if the required short term back slope ratio specified cannot be obtained.
 - 4/ Backfill and compact simultaneous to GRS-IBS construction.
 - 5/ Wrap ends of reinforcement to embed min. of 1,000mm every third layer (max.).
 - 6/ Cut "X" into bottom geosynthetic reinforcement of upper 2 courses of CMU blocks to accept rebar and concrete.
 - 7/ Wrap top layer tail of side encapsulation so that it is above top longitudinal reinforcement tail.

- LEGEND:**
- Structural Backfill
 - Open-graded backfill
 - Roadway aggregate
 - Minor concrete
 - Hollow core concrete masonry unit (CMU)
 - Solid core concrete masonry unit (CMU)
 - Concrete filled hollow core concrete masonry unit (CMU)

NAVAJO DIVISION
OF TRANSPORTATION

GRS-IBS-DETAILS
SHEET 3 OF 4

DRAWN BY: WCI	DATE: 04/19
DESIGNED BY: KRH	DATE: 04/19
REVISED: 02/25	BY: GMG

1	ADDENDUM #1	GMG	2/28/25
△	REVISION	BY	DATE

N213_GRS_IBS_DTL_3.dgn 2/27/2025 1:30:34 PM

REGION	STATE	RESERVATION	ROUTE	PROJECT NO.	SHEET	TOTAL SHEETS
NAVAJO	NEW MEXICO	NAVAJO	N5001	N5001(1)1,2&4	102	106

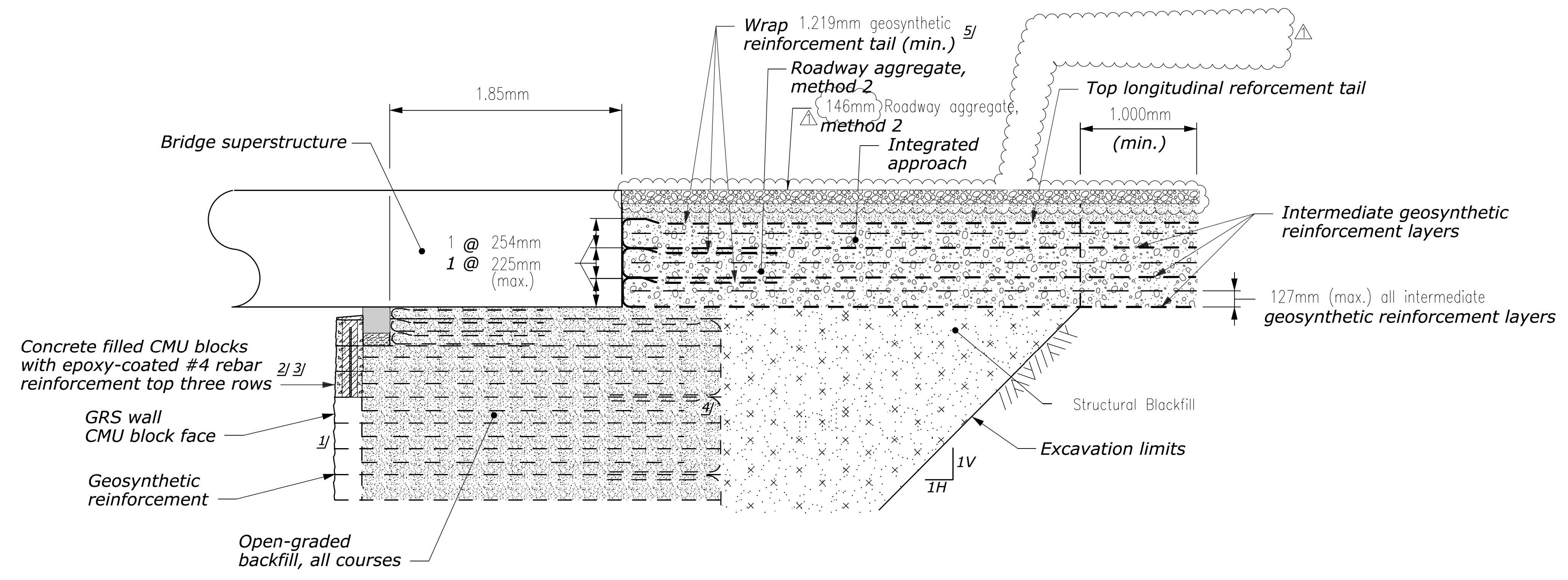

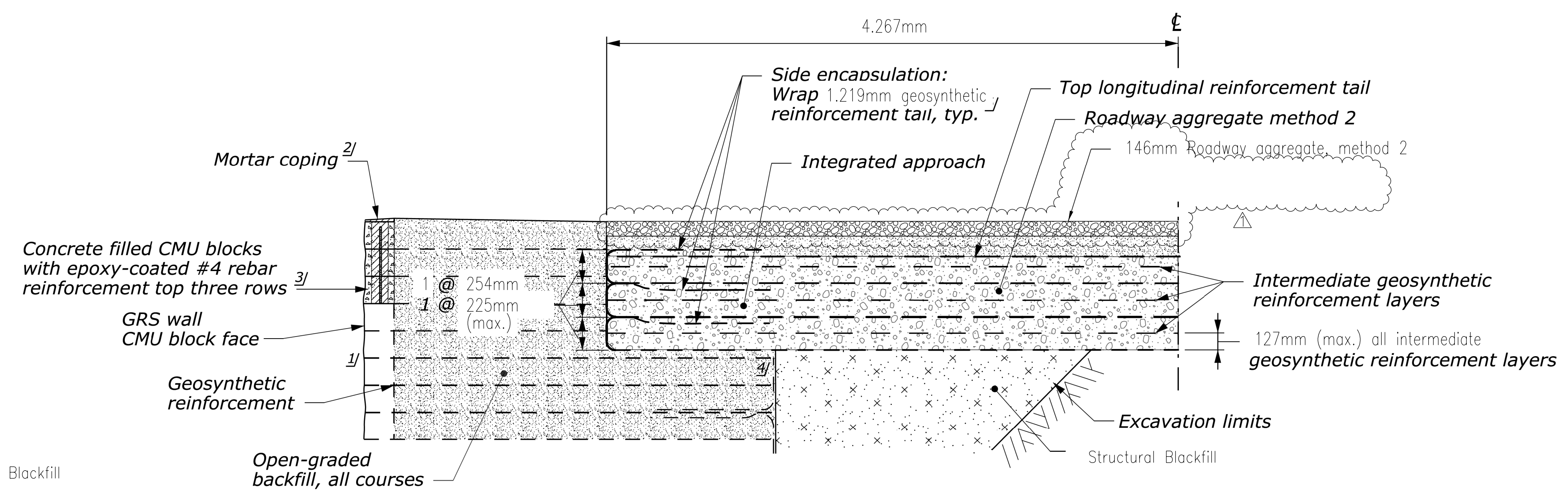

SECTION A'-A'
GRS-IBS NORTH ABUTMENT
INTEGRATED APPROACH
 NO SCALE

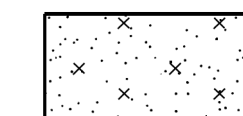
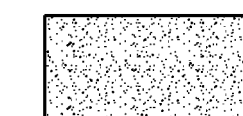
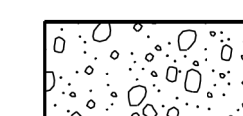
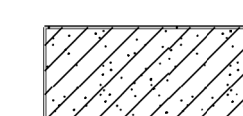
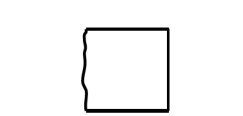

SECTION C'-C'
GRS-IBS NORTH ABUTMENT
INTEGRATED APPROACH
 NO SCALE

LEGEND:

-  Structural Blackfill
-  Open-graded backfill
-  Roadway aggregate
-  Minor concrete
-  Hollow core concrete masonry unit (CMU)
-  Concrete filled hollow core concrete masonry unit (CMU)



FOOTNOTE:

- 1/ Vertical wall face batter = 0°.
- 2/ On top row of CMU's create a mortar coping 25.4mm to 19.1mm sloped toward face to drain.
- 3/ Cut "X" into bottom geosynthetic reinforcement of upper 2 courses of CMU blocks to accept rebar and concrete.
- 4/ Wrap ends of geosynthetic reinforcement minimum of 1.000mm every third layer (max.).
- 5/ Extend top layer wrapped tail longitudinally for the full length of the integrated approach.
- 6/ Wrap top layer tail of side encapsulation so that it is above top longitudinal reinforcement tail.

NAVAJO DIVISION
OF TRANSPORTATION

GRS-IBS-DETAILS
SHEET 4 OF 4

DRAWN BY: WCI	DATE: 04/19
DESIGNED BY: KRH	DATE: 04/19
REVISED: 02/25	BY: GMG

1	ADDENDUM #1	GMG	2/28/25
△	REVISION	BY	DATE

N213_GRS_IBS_DTL_4.dgn 2/27/2025 2:21:19 PM

703.09 Chip Seal Aggregate.

Add:

- (g) Density, AASHTO T 19M Min. 70 lbs./ft³ (1100 kg/m³)
- (h) Coating and stripping of bitumen-aggregate
Mixtures, AASHTO T 182 Min. 95%

Table 703-7 is superseded with the following:

**Table 703-7
Target Value Ranges for
Single and Double Course Chip Seal Aggregate Gradation**

Sieve Size	Percent by Mass Designated Sieve (AASHTO T 27 & T 11)	
	Gradation A	Gradation C
1-inch (25 mm)	100 ⁽¹⁾	
3/4-inch (19 mm)	90 – 100 (3)	
1/2-inch (12.5 mm)	0 – 35 (5)	100 ⁽¹⁾
3/8-inch (9.5 mm)	0 - 12 (3)	70-85 (3)
1/4-inch (6.3 mm)	0-15 (5)	0-15 (5)
No.4 (4.75 mm)	-	0-5 (3)
No.8 (2.36 mm)	-	0-2 (1)
No.200 (75 μm)	0-1 (0.5)	0-1 (1)

⁽¹⁾ Statistical procedures do not apply.

() The value in the parentheses is the allowable deviation (±) from the target values.

703.12 Blotter.

This subsection is superseded with the following:

REMOVAL OF STRUCTURES AND OBSTRUCTIONS

ITEM NO. 20304-1000

STATION	TO	STATION	OFFSET	LOCATION	L.M.	EACH	REMARKS
N5001							
0+052.872		0+071.609	3.9m to 15.0m	LT	37.00		REMOVE EXISTING MASONRY WALL
0+075.107		-	23.4m	LT	23.40	1	REMOVE EXISTING CATTLEGUARD & FENCING
0+078.894		0+082.066	7.4m LT	LT		1	REMOVE EXISTING BOLLARD PAD (2m x 2m DIMENSIONS)
0+083.353		0+085.162	15m to 5.9m	LT	22.00		REMOVE EXISTING MASONRY WALL
0+085.162		0+146.126	5.9m to 7.5m	LT	65.00		REMOVE EXISTING FENCE
0+170.962		-	-	CL	10.95		EXISTING BURIED CSPC TO BE REMOVED, CLEANED & STOCKPILED
0+306.114		-	-	CL	11.60		EXISTING 610mm CSPC TO BE REMOVED, CLEANED & STOCKPILED
0+399.316		-	-	CL	12.31		EXISTING 610mm CSPC TO BE REMOVED, CLEANED & STOCKPILED
0+521.104		-	-	CL	12.29		EXISTING 547mm CSPC TO BE REMOVED, CLEANED & STOCKPILED
0+669.750		-	-	CL	12.91		EXISTING BURIED CSPC TO BE REMOVED, CLEANED & STOCKPILED
0+686.240		-	-	CL	19.87		EXISTING BURIED CSPC TO BE REMOVED, CLEANED & STOCKPILED
0+796.650		-	-	CL	26.60		EXISTING 457mm CSPC TO BE REMOVED, CLEANED & STOCKPILED
1+336.210		-	-	CL	9.16		EXISTING 610mm CSPC TO BE REMOVED, CLEANED & STOCKPILED
0+146.232		0+172.045	7.9m to 5.9m	LT	35.00		REMOVE EXISTING MASONRY WALL
1+152.120		-	-	CL	19.33		EXISTING 1829mm CSPC TO BE REMOVED, CLEANED & STOCKPILED
0+180.900		-	22.1m	LT	22.10	1	REMOVE EXISTING CATTLEGUARD, WING BRACES & FENCING
0+189.659		0+320.324	15m	LT	150.00		REMOVE EXISTING FENCE
0+190.017		0+241.415	7.2m to 29.2m	RT	80.00		REMOVE & RESET EXISTING CHAINLINK FENCE TO NEW ROW LINE. CONTRACTOR TO MAINTAIN FENCING AND SECURITY OF FISH HATCHERY DURING CONSTRUCTION
0+196.380		-	-	CL	22.83		EXISTING 1829mm CSPC TO BE REMOVED, CLEANED & STOCKPILED
0+345.050		-	10m	LT	22.10	1	REMOVE EXISTING CATTLEGUARD, WING BRACES & FENCING
0+396.913		0+467.074	15.4m to 23.3m	RT	90.00		REMOVE EXISTING FENCE
0+472.783		0+633.050	15.2m to 7.6m	LT	160.00		REMOVE EXISTING FENCE
0+481.632		-	13.9m	LT	13.90	1	REMOVE EXISTING CATTLEGUARD & FENCING
0+504.892		0+623.500	8.9m to 5.6m	RT	120.00		REMOVE EXISTING MANMADE PIPE FENCE AND SALVAGE TO PROPERTY OWNER
0+636.840		-	-	CL		1	REMOVE EXISTING MILITARY BRIDGE & ALL COMPONENTS
0+678.522		0+988.997	9.0m to 15.2m	LT	320.00		REMOVE EXISTING FENCE
0+874.000				LT	5.73		REMOVE EXISTING TURNOUT & GATE
1+152.924				CL		2	REMOVE EXISTING CONCRETE HEAD & WING WALLS
7+165.000		7+175.000	-	CL	10.00	1	REMOVE EXISTING MILITARY BRIDGE & ALL COMPONENTS
7+863.340		7+875.700	-	CL	50.00	5	5 EXISTING CSPC's TO BE REMOVED, CLEANED, & STOCKPILED

SUMMARY OF REMOVALS

DESCRIPTION	L.M	EACH
FENCE	1,050	
MASONRY WALL	100	
BOLLARD PAD		1
CATTLEGUARDS		3
CONCRETE HEADWALLS/WINGWALLS		2
EXISTING MILITARY BRIDGE STRUCTURES		2
EXISTING CULVERT PIPES	250	