

# **NAVAJO TRIBAL UTILITY AUTHORITY CONSTRUCTION REQUIREMENTS**

**Reviewed by:  
NAVAJO NATION and HIS STANDARDS COMMITTEE**



## **TECHNICAL SPECIFICATIONS FOR MATERIALS AND WORKMANSHIP FOR WATER AND WASTEWATER FACILITIES**

**Civil Engineering Department  
Ft. Defiance, AZ**

**REVISED SEPTEMBER 2008**

**TECHNICAL SPECIFICATIONS FOR MATERIAL AND WORKMANSHIP  
OF WATER AND WASTEWATER FACILITIES**

**TABLE OF CONTENTS**

<b><u>SECTION</u></b>	<b><u>PAGE</u></b>
<b>TABLE OF CONTENTS</b>	1-2
<b>DEFINITION OF TERMS</b>	3
<b>TP 1.0 EXCAVATION, TRENCHING, &amp; BACKFILLING FOR WATER &amp; WASTEWATER UTILITIES .....</b>	<b>TP 1.0-5</b>
1.01 Scope of Work .....	TP 1.0-5
1.02 Layout and Staking .....	TP 1.0-5
1.03 Protection of Excavation.....	TP 1-1-5
1.04 Protection of Existing Utilities.....	TP 1.0-6
1.05 Excavation.....	TP 1.0-6
1.05.01 General.....	TP 1.0-6
1.05.02 Grading and Stacking.....	TP 1.0-6
1.05.03 Pavement Cutting.....	TP 1.0-6
1.05.04 Rock Excavation.....	TP 1.0-6
1.05.05 De-Watering.....	TP 1.0-7
1.05.06 Excavation for Structures.....	TP 1.0-7
1.05.07 Over-Excavation.....	TP 1.0-7
1.05.08 Trench Excavation .....	TP 1.0-7
1.06 Placement and Compaction of Pipe Embedment and Backfill Material .....	TP 1.0-8
1.06.01 Pipe Embedment .....	TP 1.0-8
1.06.02 Compaction Requirements.....	TP 1.0-9
1.06.03 Water Jetting.....	TP 1.0-9
1.07 Imported Backfill.....	TP 1.0-10
1.07.01 Imported Pipe Embedment .....	TP 1.0-10
1.07.02 Imported Final Backfill.....	TP 1.0-10
1.08 Bedding and Backfill for Structures .....	TP 1.0-10
1.08.01 Bedding.....	TP 1.0-10
1.08.02 Backfill.....	TP 1.0-10
1.09 Settlement of Adjacent Structures .....	TP 1.0-10
1.10 Surface Restoration and Resurfacing.....	TP 1.0-11
1.10.01 Surface Restoration.....	TP 1.0-11
1.10.02 Roadway Patching .....	TP 1.0-11
<b>TP 2.0 WATER AND WASTEWATER LINE SEPARATION REQUIREMENTS.....</b>	<b>TP 2.0-13</b>
2.01 General .....	TP 2.0-13
2.02 Horizontal Separation of Water and Wastewater Lines.....	TP 2.0-13
2.03 Vertical Separation of Water and Wastewater Lines.....	TP 2.0-13
2.03.01 Water Line Above Wastewater Line.....	TP 2.0-13
2.03.02 Wastewater Lines Above Water Lines .....	TP 2.0-13

2.04	Water Main Separation From Manholes.....	TP 2.0-14
2.05	Water and Wastewater Service Line Separation within 5 Feet of the House .....	TP 2.0-14
2.06	Separation Between Water Lines and Components of the Wastewater Disposal System.....	TP 2.0-14
2.07	Separation Between Residence and Wastewater Lagoons.....	TP 2.0-14
<b>TP 3.0</b>	<b>WATER MAINS AND APPURTENANCES .....</b>	<b>TP 3.0-15</b>
3.01	Scope of Work .....	TP 3.0-15
3.02	Water Mains.....	TP 3.0-15
	3.02.01 Polyvinyl Chloride Pipe and Fittings (PVC) .....	TP 3.0-15
	3.02.02 Water Main Installation .....	TP 3.0-16
	3.02.03 Connections to Existing Mains .....	TP 3.0-16
3.03	Valves For Water Mains .....	TP 3.0-17
	3.03.01 Gate Valves.....	TP 3.0-17
	3.03.02 Valve Boxes.....	TP 3.0-17
	3.03.03 Valve Installation.....	TP 3.0-17
3.04	Fire Hydrant Assembly.....	TP 3.0-18
	3.04.01 Fire Hydrant.....	TP 3.0-18
	3.04.02 Hydrant Connections and Auxiliary Gate Valves.....	TP 3.0-18
	3.04.03 Fire Hydrant and Guard Installation.....	TP 3.0-18
3.05	Thrust Blocking .....	TP 3.0-18
3.06	Water Main Crossings.....	TP 3.0-18
	3.06.01 Wash Crossings.....	TP 3.0-18
	3.06.02 Road Crossings .....	TP 3.0-18
3.07	Water Service Connection Material.....	TP 3.0-19
3.08	Water Service Line Installation .....	TP 3.0-19
3.09	Pressure Tests.....	TP 3.0-19
	3.09.01 Pressure Test.....	TP 3.0-19
	3.09.02 Observation Of Tests .....	TP 3.0-21
3.10	Disinfections .....	TP 3.0-21
	Water Line Pressure Test Certification.....	TP 3.0-23
	Water Line Pressure Test Worksheet 1.....	TP 3.0-24
	Water Line Pressure Test Worksheet 2.....	TP 3.0-25
<b>TP 4.0</b>	<b>WASTEWATER MAINS AND APPURTENANCES.....</b>	<b>TP 4.0-26</b>
4.01	Scope of Work .....	TP 4.0-26
4.02	General.....	TP 4.0-26
4.03	Materials .....	TP 4.0-26
	4.03.01 Polyvinyl Chloride (PVC) Sewer Pipe .....	TP 4.0-26
	4.03.02 Polyvinyl Chloride (PVC) Sewer Pipe Fittings .....	TP 4.0-26
	4.03.03 Ductile Iron Sewer Pipe.....	TP 4.0-27
	4.03.04 Ductile Iron Pipe Fittings.....	TP 4.0-27
	4.03.05 Precast Concrete Manhole Sections.....	TP 4.0-27
	4.03.06 Manhole Covers and Frames .....	TP 4.0-27
	4.03.07 Manhole Steps.....	TP 4.0-27

4.03.08	Concrete .....	TP 4.0-28
4.03.09	Wastewater Cleanout and Frame .....	TP 4.0-28
4.04	Installation Of Sewer Pipe .....	TP 4.0-28
4.04.01	Pipe Laying .....	TP 4.0-28
4.04.02	Depth of Bury .....	TP 4.0-29
4.04.03	Installation of Service Connections .....	TP 4.0-29
4.05	Manhole Installation .....	TP 4.0-29
4.05.01	General.....	TP 4.0-29
4.05.02	Connection To Existing Manhole.....	TP 4.0-30
4.06	Wastewater Main Crossings .....	TP 4.0-30
4.06.01	Wash Crossings.....	TP 4.0-30
4.06.02	Road Crossings .....	TP 4.0-30
4.08	Wastewater Line Testing .....	TP 4.0-31
4.08.01	Alignment Test.....	TP 4.0-31
4.08.02	Deflection Test.....	TP 4.0-31
4.08.03	Ex-filtration Test.....	TP 4.0-32
4.08.04	Groundwater Infiltration.....	TP 4.0-33
4.09	Manhole Testing .....	TP 4.0-33
4.10	Observation of Pressure Test .....	TP 4.0-34
	Wastewater Main/Manhole Test 1 Certification.....	TP 4.0-35
	Wastewater Main/Manhole Test 1 Worksheet.....	TP 4.0-36
	Wastewater Main/Manhole Test 2 Certification.....	TP 4.0-37
	Wastewater Main/Manhole Test 2 Worksheet	TP 4.0-38

**TP 5.0 FINAL SITE UTILITY INSPECTION REQUIREMENTS .....TP 5.0-39**

5.01	Final Inspection Package .....	TP 5.0-39
5.01.01	As-Built Drawings .....	TP 5.0-39
5.01.02	As-Built Notebook .....	TP 5.0-39
5.02	Scheduling Final Inspection.....	TP 5.0-39
5.03	As-Built Drawing Requirements.....	TP 5.0-40
5.03.01	General Requirements for all Sheets.....	TP 5.0-40
5.03.02	Cover Sheet.....	TP 5.0-40
5.03.03	Plat Sheet .....	TP 5.0-41
5.03.04	Utility Plan View Sheet(s) .....	TP 5.0-41
	Water/Wastewater Plan and Profile Sheet(s).....	TP 5.0-44
	Cost of Plant (Example).....	TP 5.0-45
	Utility Transfer Agreement.....	TP 5.0-46

**DRAWING STANDARDS AND LEGEND**

**DEFINITION OF TERMS:**

- Owner:** The organization or its representative authorizing and administering the construction project.
- Contractor:** The organization or its representative performing the construction.
- Operating Utility:** The organization or its representative operating the water and wastewater utility affected by the construction.
- Roadway Authority:** The authority or agency with jurisdiction over the roadway.
- Or Approved Equal (OAE):** A substitute in material that is considered by the **Operating Utility** to be equal to or better than the item listed in the specifications or standards.
- NTUA:** The utility owner, **Navajo Tribal Utility Authority**

## **TECHNICAL PROVISIONS 1.0**

### **TP 1.0 EXCAVATION, TRENCHING, AND BACKFILLING FOR WATER AND WASTEWATER UTILITIES**

#### **1.01 Scope of Work**

The work covered by this section includes the furnishing of all plant, labor, tools, equipment, and material, and performing all operations in connection with excavating, trenching, and backfilling, for installations of all water/wastewater utility pipelines, related structures, and accessories. This includes the necessary clearing and grubbing, pavement cutting, compaction, pavement restoration, grading, and cleanup, all in accordance with these Technical Provisions and applicable drawings. The final installation also shall meet the requirements of Section 2.0, Water, and Wastewater Line Separation Requirements.

If there is a conflict between these Technical Provisions and any other section of the specifications and/or drawings, then the most stringent, as determined by the Owner and/or NTUA shall apply.

#### **1.02 Layout and Staking**

All layout and staking for site work shall be performed by a licensed engineer or land surveyor, approved by the Owner and/or NTUA, who is to be paid by the Contractor, unless other arrangements are negotiated. Copies of survey notes shall be submitted to the Owner and the NTUA, with one or more copies remaining on the job site at all times.

#### **1.03 Protection of Excavations**

The Contractor shall provide suitable sheathing, shoring, and bracing to protect all excavations as required, to provide safe working conditions as directed by the NTUA. and in conformance with applicable OSHA and all other safety regulations. The Contractor at his expense shall repair damages resulting from settlements, slides, cave-ins, flooding, pipeline breaks, and other causes. Suitable signs shall be so placed as to show in advance where construction, barricades, or detours exists.

The Contractor shall at all times perform his work to insure the least possible obstruction to traffic, inconveniences to the general public and residents in the vicinity of the work, and to insure the protection of persons and property in a manner satisfactory to the Owner and the NTUA.. No road or street shall be closed to the public except with the permission of the proper authority. Fire hydrants on or adjacent to the work site shall be kept accessible to fire-fighting equipment at all times. Temporary provisions shall be made by the Contractor to insure the use of sidewalks, and the proper functioning of all gutters, sewer inlets,

drainage ditches, and irrigation ditches.

#### **1.04 Protection of Existing Utilities**

It shall be the Contractor's responsibility to determine the locations of all known existing underground utilities not shown on the drawings and to confirm the exact locations of those existing utilities shown on the drawings. All existing utilities shall be protected from damage, during excavation and backfilling of trenches and if damaged, shall be repaired at the expense of the Contractor.

#### **1.05 Excavation**

##### **1.05.01 General**

It is expected that all excavation required for the performance of the work shall be made by open cut methods unless otherwise specified and shown on the drawings or as required by applicable permits.

##### **1.05.02 Grading and Stacking**

All grading in the vicinity of the construction shall be controlled to prevent surface water from flowing into the excavation. Any water accumulated in the excavation shall be removed by pumping or other approved method. During excavation, material suitable for embedment and backfilling shall be piled in an orderly manner, a sufficient distance back from the edges of the bank to avoid overloading and to prevent slides or cave-ins. Material unsuitable for backfilling shall be hauled from the job site and disposed of by the Contractor at approved disposal sites.

##### **1.05.03 Pavement Cutting**

Where it is necessary to remove sections of asphalt pavement, the asphalt shall be clean-cut with approved equipment in a neat line 6 inches back from the outside edge of the excavation, in order to provide a key when restored.

Where it is necessary to remove sections of concrete pavement, the concrete shall be saw-cut to a depth of not less than 1-1/2-inches with neat vertical lines in such a manner that the adjoining surfaces will not be damaged.

##### **1.05.04 Rock Excavation**

If given special consideration, rock is considered to exist when excavation cannot be accomplished using a 790E John Deere Class

track hoe with a rock bucket, without stressing the machine. The NTUA shall be the sole party in determining the existence of rock and the appropriate means of removal. The quantity of rock shall be determined in cubic yards of material removed. All other trenching and excavations, regardless of materials encountered, equipments used, or methods required for excavation, will be unclassified.

**1.05.05 Dewatering**

The Contractor shall remove and dispose of all water entering the trenches and shall keep the trenches water free until the water or wastewater lines and other appurtenances are in place. In no case shall water, earth, or any foreign materials be allowed to enter the water or wastewater pipelines.

**1.05.06 Excavation for Structures**

Excavation for appurtenances such as manholes, valves, foundations, catch basins, culverts, subterranean formwork, and other structures shall be to the necessary depth and sufficient width to leave at least 12-inches of space between the structure's outer surface and the embankment or shoring used to stabilize the banks.

**1.05.07 Over-Excavation**

Whenever solid or loose rock, rocky soil with rocks larger than 3/4-inches in their largest dimension, or otherwise unsuitable soils which are incapable of properly supporting the pipe or structure are encountered in the trench bottom, all unsuitable material, as determined by the Owner and NTUA, shall be over-excavated to a minimum depth of 6-inches below the pipe or structure and removed.

Except at locations where over-excavation is required, care shall be exercised not to excavate below the depths indicated. In the event of accidental over-excavation, the trench bottom grade will be restored in the same manner as areas specified to be over-excavated.

**1.05.08 Trench Excavation**

The sides of all trenches for the installation of utility piping system shall be as nearly vertical as soil conditions will allow from ground level to the pipe. Except for the trenching of 1-inch water service lines, the width of the trench shall be a minimum of 16-inches and a maximum of 30-inches wider than the outside diameter of the pipe. Trench excavation shall be centered on pipe alignment such that a minimum clearance of 8-inches is provided on each side of the pipe. Trench width



above the level of the top of the pipe may be as wide as necessary for shoring or sheathing and for proper installation of the work.

The depth of all trenches shall be as indicated on the drawings. If not otherwise specified, the depth of all trenches shall be in accordance with the specifications for the installation of waterlines and wastewater lines.

Unless otherwise required by applicable permits, the maximum length of trench that may be left open at any one time shall not exceed 500 feet.

## **1.06 Placement and Compaction of Pipe Embedment and Backfill Material**

### **1.06.01 Pipe Embedment**

Pipe embedment: Pipe embedment is defined as that material required to bring the trench bottom up to surface grade and that material placed alongside and above the pipe to a level of at least 6-inches over the top of the pipe. Pipe embedment shall be selected earth or sand, which contain no stones, dry or frozen lumps greater than 3/4-inch in diameter, or other unsuitable material as defined by the NTUA. Embedment and the first 6-inches of backfill, above the top of the pipe in rock excavation shall be done in the presence of the NTUA. Any backfilling, done in violation of this provision shall be cause for removal and replacement of the embedment, at the expense of the Contractor even though the work is found to be in accordance with these specifications.

Bedding: Bedding is that portion of pipe embedment zone beneath the pipe. If the native soil is suitable for bedding, the bottom of the trench shall be accurately shaped to provide uniform bearing and support for the entire length of the pipe. Bell holes shall be excavated to provide minimum clearances of 2-inches below the couplings or bells. Imported bedding material shall likewise be placed to provide uniform and adequate longitudinal support under the pipe. Bedding material shall be placed and compacted in lifts not to exceed 6-inches in loose measure.

Haunching: Haunching is that portion of the pipe embedment zone from the bottom of the pipe to the spring line of the pipe. Haunching material shall be placed and hand tamped to provide adequate side support to the pipe while avoiding both vertical and lateral displacement of the pipe from proper alignment.

Initial Backfill: Initial backfill is that portion of the pipe embedment zone from the spring line of the pipe to a minimum of 6-inches above the top of the pipe. Initial backfill material shall be placed and compacted in lifts not to exceed 6-inches in loose measure. Compaction shall be performed in such a manner so as to avoid damage and

disturbance of the embedded pipe.

Final Backfill: Final backfill is defined as that material used in the area between the initial backfill and the existing ground surface. Material shall be placed and compacted in lifts not to exceed 6-inches in loose measure except as otherwise specified.

**1.06.02 Compaction Requirements**

Unless otherwise specified by permit issued by the roadway authority or by special arrangement between the NTUA, bedding, haunching, initial backfill, final backfill, and gravel resurfacing shall be compacted to the following percentages of the maximum density as determined by ASTM D1557. (If using Standard Proctor ASTM D-698, add 5% to all compaction requirements listed in the table below). In-place densities of materials shall be determined by the sand-cone method, ASTM D1556 or by the nuclear method, ASTM D2922.

Percent of Maximum Density - D1557

Backfill Location	Bedding Backfill	Haunching Backfill	Initial Backfill	Final Backfill
Roadway Rights-of-Way Within Roadway Prism	95% *	95%	95%	95%
Roadway Rights-of-Way Outside of Roadway Prism	90% *	90%	90%	95%
All Other Conditions	90%	90%	90%	90%

\* or the existing condition within the undisturbed bottom of the trench.

**1.06.03 Water Jetting**

The introduction of water to the pipe embedment or final backfill material shall not be permitted as a means of compaction.

**1.07 Imported Backfill**

**1.07.01 Imported Pipe Embedment**

If the native soil is unsuitable, the Contractor shall import suitable pipe embedment material. Pipe embedment shall be select earth or sand which contains no stones, dry lumps, or frozen lumps greater than 3/4-inches in diameter and shall be defined as 100% passing 3/4-inches, 40-99% passing # 4 sieve and 30% or less passing # 200 sieve. Unsuitable material is defined as solid or loose rock, soils with rocks larger than 3/4-inches in their largest dimension, or other unsuitable

soils which are, as determined by the NTUA, incapable of properly supporting the pipe.

#### **1.07.02 Imported Final Backfill**

If the native soil is unsuitable for use as final backfill, the Contractor shall import suitable final backfill. Imported final backfill may be any material, which is locally available and is capable of being compacted to the required density. This material shall be free of boulders and rocks larger than 6-inches in their smallest dimension, frozen clumps of dirt, organic material, or rubble, which could damage the pipe.

### **1.08 Bedding and Backfill for Structures**

#### **1.08.01 Bedding**

Bedding material for structures is defined as that material beneath the structure. This material shall be as specified in the standard detail for each structure.

#### **1.08.02 Backfill**

Backfill for structures is defined as that material from the bottom of the structure to the existing ground surface. This material and the required compaction of such shall be the same as that specified for in the final backfill on pipelines, or as specified in the drawings.

### **1.09 Settlement of Adjacent Structures**

Throughout the 1-year warranty period, the Contractor shall be required to fill and compact any areas where settlement has taken place and shall also be responsible for the settlement of any adjacent structure or object caused by any excavation performed under his contract.

### **1.10 Surface Restoration and Resurfacing**

#### **1.10.01 Surface Restoration**

The following requirements shall be followed unless alternative specifications are set forth by the roadway or other rights-of-way crossing permits, or as arranged between the NTUA and the NMDOT.

After the piping and structures have been installed and all backfilling completed, areas, which were disturbed, shall be brought to true grades. All slopes shall be trimmed and dressed, and all surface graded to maintain existing drainages. All streets, alleys, driveways, sidewalks,

curbs, or other surfaces, which have been disturbed or damaged, shall be resurfaced or replaced. The Contractor shall properly dispose of all excess excavated materials.

As required by the operating utility, the contractor shall install the utility brand Carsonite markers at all road crossings, water valves, fittings, junctions, connections, points of intersection, or at a minimum, every 1500 feet. Naturally, this would apply only within the rural areas, along stretches of roadways, or as requested by the operating utility. This is also a requirement for marking sewer manholes, cleanouts, and service connections.

#### **1.10.02 Roadway Patching**

Whenever existing roadways are disturbed during the course of construction, the Contractor shall restore the roadways to their original condition.

For ease of compaction, the Contractor may use well-graded gravel, crushed stone, or flowable fill as backfill, from a Ready Mix plant as approved by the appropriate roadway agency. The material shall be clean, varying in size from 3/8-inches to 1-1/4-inches, with not more than 10 percent of the material less than 3/8-inches in size and shall be compacted in 6-inch layers or as directed by the NMDOT. Flowable fill is defined as one bag concrete, with gradations of 100% passing the 3/8 sieve, and less than 25% passing the #200 sieve. The slump should be between 5-inches and 8-inches, and the 28-day strength should be between 50 and 150-PSI.

Surfacing shall be replaced where the roadway has gravel, crushed stone, asphaltic, or concrete surfacing. Gravel or crushed stone shall be replaced in quantities and locations as directed by or as required by the roadway permitting authority. Asphalt mix or concrete surfacing shall be replaced, in the case of asphalt, appropriately compacted in roadways to a depth equal to existing roadway surface but not less than 2-inches in asphalt or 6-inches in concrete. A compacted stabilized gravel or crushed stone base 6-inches in depth shall be placed in the roadway at all locations where surfacing is required prior to placement of the bituminous or concrete wear course, unless other requirements are stipulated by the roadway authority.

The Contractor shall obtain any and all necessary written permissions, easements, and permits from federal, state, and county agencies prior to beginning any roadway excavation.

## **TECHNICAL PROVISIONS 2.0**

### **TP 2.0 WATER AND WASTEWATER LINE SEPARATION REQUIREMENTS**

#### **2.01 General**

Water lines located near wastewater facilities present conditions for serious potential cross contamination. Protection from cross contamination can be provided by separation of the facilities and use of special piping materials. For measuring separation between pipes, all measurements shall be the clearances between pipes. (Pipe O.D. to pipe O.D.).

#### **2.02 Horizontal Separation of Water and Wastewater Lines**

When water and wastewater lines are laid parallel to each other, the horizontal distance between the water and wastewater lines shall not be less than 10 feet. Each line shall be laid in separate trenches. The requirements for this separation shall apply to all other buried utilities, except the distance may be reduced to 5 feet for secondary electric and gas distribution lines less than 60-PSIG; however, all stipulations of the electric, gas, or other sub-surface utilities shall be met.

When physical conditions such as an existing obstruction, will not allow the required 10-foot horizontal separation, the water and wastewater mains may be laid closer than 10 feet if the bottom of the water main is a minimum of 12 inches above the top of the wastewater main and prior written approval is granted by the NTUA.

#### **2.03 Vertical Separation of Water and Wastewater Lines**

##### **2.03.01 Water Above Wastewater**

When waterlines cross wastewater lines, the waterline shall cross above the wastewater line with a minimum vertical separation of 12 inches. If necessary, the depth of bury for the waterline may be reduced to 36 inches (normally 42 inches) at the crossing to maintain the 12-inch vertical separation. No joints in new waterlines shall be permitted within 10 feet of crossing a wastewater line.

##### **2.03.02 Wastewater Above Water**

When a waterline must cross below a wastewater line, the minimum vertical separation between the lines is 12 inches. Backfill of the trenches shall be compacted to provide adequate support to prevent settling of the wastewater line and damaging the water line.

For new water construction, the waterline shall be normal PVC water pipes with 20-foot pipe sections centered on the wastewater crossing.

No joints of new waterline construction shall be permitted within 10 feet of crossing a wastewater line. While it is desirable to have all crossings perpendicular or normal, new waterlines (centered on the crossing) may cross under a wastewater line at a maximum of 25° from perpendicular.

For new wastewater construction, the wastewater line shall be ductile iron pipe with gasketed joints, or approved equal (OAE), with an 18-foot section centered on the crossing. No joints in new wastewater line construction shall be permitted within 9 feet of crossing a water line.

**For water and wastewater lines crossing electric, gas, or other buried facilities; the standards established by that other specific utility must be met.**

**2.04 Water Main Separation from Wastewater Manholes**

No waterline pipe shall pass through, under, or come into contact with any part of a wastewater manhole.

**2.05 Water and Wastewater Service Line Separation Within 5 feet of the House**

This section shall apply to that portion of water and wastewater service lines located within 5 feet of the house. All lines within 5 feet of the house will be considered as part of the house plumbing. For new construction, all service lines shall have a 10-foot minimum horizontal separation. This can be accomplished by having the water and wastewater service lines exit the house 10 feet apart or from different sides. If the 10-foot separation cannot be maintained and prior written approval is obtained from the NTUA, the service lines can be laid closer than 10 feet, if the bottom of the water service line is at least 12-inches above the top of the wastewater service line; and the water service line is continuous with no joints until the separation requirement is met.

**2.06 Separations Between Waterlines and Components of the Wastewater Disposal System**

Waterlines shall not be installed within 10 feet of a septic tank, within 25 feet of a drain field, or 50 feet from an outhouse. Also, waterlines shall not be installed within 100 feet of the perimeter fence of an **individual** lagoon, or within 500 feet of the perimeter fence of a **community** lagoon.

**2.07 Separation Between Residences and Wastewater Lagoons**

No permanent residence shall be within 1000 feet from the perimeter fence line of a **community** sewer lagoon, or within 300 feet from the perimeter fence line of an **individual** sewer lagoon without written consideration of the Operating Utility.

## **TECHNICAL PROVISIONS 3.0**

### **TP 3.0 WATER MAINS, WATER SERVICE LINES, AND APPURTENANCES**

#### **3.01 Scope of Work**

The work covered by this section includes the furnishing of all labor, equipment and tools, and material; performing all operations in connection with the construction of water mains, including the placing of all necessary valves, hydrants, fittings, and appurtenances, and the construction of water service lines and appurtenances, in accordance with these technical provisions and applicable drawings.

#### **3.02 Water Mains**

##### **3.02.01 Polyvinyl Chloride (PVC) Pipe and Fittings**

Fittings for PVC pipe 4-inch and larger shall be Class 350 SSB mechanical joint, ductile iron conforming to AWWA C153 and shall be cement mortar-lined conforming to AWWA C104 or if shown on the plans, may be Class 200 PVC Bell and Gasket, conforming to ASTM D3139 and D1784, Type 1, Grade 1, and ASTM D2241.

PVC pipe shall conform to ASTM D2241 and the pipe shall be PVC 1120, SDR 21 and 200-PSI pressure rating or SDR 26 and 160-PSI, as specified on the plans. All PVC pipe joints shall be rubber compression ring type gaskets conforming to ASTM D3139 - Rieber type or equal. Special piping provisions are required when higher pressures are encountered.

Plastic pipe with scratches, gouges, or grooves deeper than one-tenth (0.10) of the wall thickness shall be rejected. Damaged sections of pipe shall be completely destroyed or immediately removed from the job site.

Ductile Iron pipe of specific class and type as shown on the plans may be required under certain circumstances. The pipe may require polyethylene encasement. In cases where the soil environment is corrosive -the soil resistivity is less than 1000 ohm-cm, the PH is less than 4 or greater than 8.5, or sulfides or high moisture content exist in the soil, etc. -the Contractor shall be required to wrap all mechanical joint fittings and all Ductile Iron pipe with 9 mill polyethylene film per AWWA C105/A21.5.

### **3.02.02 Water Main Installation**

Pipe and fittings shall be installed generally in accordance with the manufacturer's printed instructions and specifications, to the standards of the AWWA for installing the type of pipe used, and in accordance with the NTUA Technical Provisions. Minimum bury depth shall be 42-inches, unless otherwise specified, with a maximum depth of 72-inches, unless specifically exempted by the NTUA Engineer.

Pipe and fittings shall be carefully handled to avoid damage. Dirt or other foreign material shall be prevented from entering the pipe or pipe joint during handling or laying operations and any pipe or fitting that has been installed with dirt or foreign material shall be removed, cleaned, and re-laid. When pipe installation is not in progress, the open ends of the pipe shall be closed with a watertight plug.

Long radius curves, either horizontal or vertical, may be installed with standard pipe by deflecting at the joints. The amount of deflection at each pipe joint shall not exceed the manufacturer's printed recommended deflections. When rubber gasket pipe is laid on a curve, the pipe shall be jointed in a straight alignment and then deflected to the curved alignment. Trenches shall be excavated wider on curves for this purpose.

### **3.02.03 Connections to Existing Mains**

A permission to tap permit shall be obtained from the local NTUA office by the Contractor and all work shall be in conformance with said tapping permit.

Connections to existing mains shall be dry connections, made in a neat and workmanlike manner, unless otherwise permitted by the NTUA. Each connection to an existing waterline shall be made at a time and under conditions which will least interfere with water services to customers affected thereby, or as authorized by the NTUA and as evidenced by an approved tapping permit. Such connections shall be made to the satisfaction of the NTUA. Proper tools and fittings to suit actual conditions encountered in the field in each case shall be utilized. The cutting of pipe for inserting fittings or closure pieces shall be done in strict accordance with the recommendations of the pipe manufacturer, without damage to the pipe, or coating, and so as to leave a smooth end at right angle to the axis of the pipe.

Great care shall be taken to prevent pipeline contamination when cutting into and making connections with existing pipelines used for the conveyance or distribution of water for domestic or public use. The



Contractor shall coordinate and cooperate with the NTUA, in locating services and shall conduct his operations in such a manner that trench water, mud, or other contaminations are not allowed to enter the connected line or lines, at any time during the progress of the work. The interior of all pipe, fittings, and valves installed in such connections shall be thoroughly cleaned and then swabbed with or dipped in strong chlorine solution having a chlorine content of 200 parts per million (PPM).

### **3.03 Valves For Water Mains**

#### **3.03.01 Gate Valves**

All gate valves shall conform to AWWA Specification C509, iron body, epoxy coated, bronze mounted, resilient wedge, counter clockwise opening, inside screw, non-rising stem with O-ring seals, and a 2-inch square wrench nut. Valve working pressure rating shall be 200-PSI minimum. The valves shall be Mueller, Kennedy, Waterous, Dresser M & H, Clow, or an approved equal (OAE) with mechanical joints as specified on the plans with appropriate transition gaskets. For operating pressures greater than 200-PSI, special considerations shall be followed.

#### **3.03.02 Valve Boxes**

Valve boxes shall be installed on all buried valves and shall be 5-1/4-inch nominal diameter shaft, two-piece adjustable screw type equal to Tyler No. 6850 Series. The length of the box shall be sufficient to permit access to the valve at the specified depth of bury. Tyler Series extensions will be utilized to extend the valve box where required. The word "Water" shall be cast onto the lid.

#### **3.03.03 Valve Installation**

Before installing the valve, care shall be taken to see that all foreign material and objects are removed from the interior of the valve. The valve shall be opened and closed to see that all moving parts are in working order, prior to installation.

All valves shall be set and jointed to the pipe in the manner as set forth in the AWWA Standards for the type of connecting ends furnished. All valves shall be set in and tied to poured in-place concrete support blocks as per the NTUA standard detail. Valves and valve boxes shall be set plumb. The cast iron valve boxes shall be placed over valves in such a manner that the valve boxes do not transmit shock or stress to the valve. The valve box cover shall be set flush with, or slightly above the

finished grade, as shown per the NTUA standard detail. A 2-foot square by 4-inch deep reinforced concrete pad shall be poured around each valve box. Before the concrete hardens, the Contractor shall neatly scribe in the concrete pad, the valve and pipe size and type, and a line indicating the direction of flow of water through the valve.

### **3.04 Fire Hydrant Assembly**

#### **3.04.01 Fire Hydrant**

Fire hydrants shall be of standard manufacture with the name of the manufacturer and direction of opening cast on the hydrant top. Fire hydrants shall conform to AWWA C502. The end connections shall be mechanical joint. The hydrants shall be equipped with a breakaway safety flange and safety stem coupling at or near the bury line such that a heavy impact would minimize breakage of hydrant parts. The hydrants shall open counter clockwise, have a 5 1/4-inch or larger main valve opening, 6-inch inlet, 1 1/2-inch tapered pentagonal operating nut, 2 hose nozzles 2 1/2-inches in diameter, and a 4 1/2-inch pumper nozzle, all with National Standard hose threads. The hydrant shall be Mueller A423, Kennedy K81A, or an approved equal OAE.

#### **3.04.02 Hydrant Connections and Auxiliary Gate Valves**

An auxiliary gate valve and valve box shall be installed adjacent to each fire hydrant per the standard detail or as specified on the plans. The pipe between the fire hydrant and the auxiliary gate valve and between the auxiliary gate valve and the main shall be 6-inch minimum.

#### **3.04.03 Fire Hydrant and Guard Installation**

Before installing any hydrant, care shall be taken to see that all foreign materials and objects are removed from the interior of the barrel. The hydrant shall be opened and closed to see that all moving parts are in working order.

Hydrants shall be installed plumb with the pumper nozzle toward the street. The hydrant shall be set per the standard detail for the hydrant and guard.

### **3.05 Thrust Blocking**

Thrust blocking as detailed in the standard drawings shall be placed at all bends, caps, tees, crosses, and fire hydrants. Blocking shall be concrete mix poured in place. Concrete blocking shall bear against solid undisturbed earth at the sides and bottom of the trench excavation and shall be shaped so as not to block weep

holes or obstruct access to the joints of the pipes or fittings. The concrete shall not cover nuts and bolts of joints or fittings. Ductile Iron Joint Restraints used in conjunction with Mechanical Joint fittings may be used as a substitute for concrete blocking.

### **3.06 Water Main Crossings**

#### **3.06.01 Wash Crossings**

Water mains shall be installed as shown on the plans. The Contractor shall divert surface flows, conduct dewatering, and perform all steps necessary to maintain proper bedding conditions and alignment. A minimum 6-foot depth of bury is required at the centerline of all wash crossings.

#### **3.06.02 Road Crossings**

In lieu of boring, roads may be open cut for water line and casing installation. The original surface pavement on all open cut roadways shall be either cut square or sawed straight. As with open cut, if boring is required the steel conduit shall be extended from right-of-way to right-of-way. The Contractor shall obtain written permission from the appropriate agency prior to beginning any roadway excavation. Backfill within the limits of a roadway prism may require special compaction in accordance with the requirements of the roadway crossing permits.

Surfacing shall be replaced where the roadway has gravel, concrete, or asphaltic paving in the same thickness as were removed, or as specified by the roadway agency, and completed as soon as possible following backfilling.

Ductile iron pipes resting on the bells within the steel casing shall be used as the carrier pipes. PVC waterline road crossings may also be installed within the steel casing on approved casing chocks or redwood skids secured to the pipe with stainless steel straps. The casing ends shall be sealed with an approved rubber boot or 9-mil plastic sheeting with stainless steel clamps. Casing pipe shall be straight welded Schedule 10 steel pipe, .25-inch wall thickness, unless otherwise specified. An alternate method for roadway crossing is to install ductile iron pipe, Class 52, bell and spigot, direct bury by open cut excavation from right of way to right of way. This would be considered when crossing minor roads or trails, or for congested area within an urban setting.

For pressure testing purposes, gate valves will be required on the up

stream and downstream side of roadway crossings.

### **3.07 Water Service Connections Material**

#### **3.07.01 Polyethylene (PE) Pipe**

Polyethylene (PE) pipe shall be 1-inch IPS, 200 psi, SIDR 7 in conformance with ASTM D2239. The pipe shall be produced from a high density ultra-high molecular weight PE pipe compound, PE 3406 or PE 3408 which conforms to the latest revision of ASTM D1248. The pipe shall be equal to Driscopipe 5100 Ultral-line or Yardley Ultra-high Molecular Weight PE. The designation PE 3406 or PE 3408 shall be stamped on the pipe.

#### **3.07.02 Service Line Fittings and Connections**

Fittings and connections for PE pipe shall be made with non-flare compression connections and shall be Mueller Insta-Tite H-15426, or approved equal. All threaded connections from the water main to and including the inlet of the domestic stop shall be standard iron pipe (I.P.) threads.

#### **3.07.03 Saddles**

Saddles shall be specific for the type, size, and pressure rating of the mainline as recommended by the saddle manufacturer. Saddles shall be double strapped, double banded, or of the contoured band type. Saddles and saddle components shall be brass, bronze, or stainless steel. Tap threads shall be FIP. Acceptable saddles include Ford S71 and Mueller H-13478 for IPS PVC O.D. pipe, or Ford 202B or approved equal for DI and AC O.D. pipe.

#### **3.07.04 Corporation Stops**

Corporation stops shall be bronze alloy with MIP threads inlet by FIP threads outlet. They shall be equal to Mueller H-10046 corporation stops or Ford Type FB1700.

#### **3.07.05 Curb Stops**

Curb stops shall be 1-inch bronze alloy, quarter turn check, FIPT x FIPT end connections, with tee head and 30-inch (approx.) stationary operating rod. Curb stops shall be Minneapolis pattern top threads with resilient O-rings seals and equal to the Mueller B-20287, or Ford B11-444M or AY McDonald 6105.

### **3.07.06 Curb Stop Boxes**

Curb stop boxes shall be the extension type, cast iron with 1 1/2-inch upper section. Curb box lid shall be cast iron and have a countersunk brass pentagon head plug. The curb stop boxes shall be Minneapolis pattern 2-inch base bushed to 1 1/2-inch and equal to Mueller H-10302 or Ford Type PXL. The finished elevation of the plug shall be such that it extends just slightly above the ground surface. The stationary rod shall be sized so that the top extends 2 to 4 inches below the top of the curb box. An 18-inch by 18-inch by 4-inch depth reinforced concrete collar shall be poured around each curb box.

### **3.07.07 Water Meters**

Water meters shall be of cast bronze construction with magnetic drive and a hermetically sealed register which reads in gallons. The meter shall accurately record flows from 1/4 to 20 gpm and shall be a 5/8-inch by 3/4-inch Sensus SR model with frost plate. The Sensus SR II model is not acceptable.

### **3.07.08 Meter Yokes/Coppersettters**

Yokes or coppersettters for water meters shall have 3/4-inch ID x 12-inch riser, with a ball valve with padlock wing angle on the inlet, with a meter nut on the outlet side, and in the base, a 1-inch double purpose union swivel inlet and outlet connection. Yokes shall have an eye for the insertion of a cross brace and equal to Ford VB 72-12W-11-44 or AY McDonald 20-212WX-DD-44. The cross brace shall be a 1/2-inch OD PVC pipe or # 4 rebar 18-inches in length. The tandem coppersetter shall have an "S" tube with two bronze adapters, iron thread by meter nut, for the pressure regulators. The PRV shall be Watts Series 25AUB or approved equal.

### **3.07.09 Meter Boxes**

Meter boxes shall be 20-inches diameter, 30-inches high nonmetallic by DFW or approved equal and shall be extended a minimum of 1-inch below the service line. The meter box lid shall be a cast iron, double lid cover with 11-1/2-inches lid opening, plastic or aluminum inner lid, and locking outer lid with pentagon head worm type lock. The meter box cover shall be equal to Castings model M 70.

### **3.07.10 Domestic Stops (Not part of the NTUA's facilities)**

Domestic stops shall be a 1-inch bronze alloy, quarter turn check, FIPT x FIPT end connections, with tee head and 39-inch stationary operating

rod. They shall have resilient O-rings seals and equal to the Ford B11-444 or AY McDonald 610.

### **3.07.11 Domestic Stop Valve Boxes (Not part of the NTUA's facilities)**

The domestic stop valve box shall consist of 3-inch diameter PVC-DWV pipe with a 3-inch hub by FIP threaded adapter with a 3-inch MIP threaded plug for the lid. The finished elevation of the plug shall be such that the stationary rod is located immediately below or within the plug so that the rod can be operated with an adjustable wrench from ground surface with the plug removed. The 3-inch diameter PVC-DWV pipe shall be cut so that the top of the adapter extends 3 to 6-inches above ground surface.

### **3.08 Water Service Line Installation**

Water service lines and appurtenances shall be installed in accordance with TP 1.0, Excavation, Trenching, and Backfilling for Water and Sewer Utilities, and TP 2.0, Water and Sewer Line Separation Requirements. A minimum of 3 feet of cover is required for water service lines.

Service lines shall be cut using tools specifically designed to leave a smooth, even, and square end on the pipe. The cut ends shall be reamed to the full inside diameter of the pipe. Pipe ends are to be connected using fittings which seal to the outside surface of the pipe which shall be cleaned to a sound smooth finish before installation. Splices shall be kept to a minimum and no splices shall be made within 10 feet of any sewer line.

All 1-inch service connections to water mains 4-inches or larger shall be made using saddles (tap tees are permitted for new construction). Service connections to 2-inch pipe shall be made using tees. Particular care shall be exercised to assure that the main is not damaged by the installation of the saddle. The saddle shall be aligned on the water main so that it is at a 45 degree angle above the springline of the pipe. The hole drilled into the pipe through the saddle shall be no smaller than 1/8-inch less than the size of the saddle.

Where required, the Contractor shall reconnect existing water service connections to the new water mains using materials specified herein. Individual pressure reducing valves, where required, shall be installed on a tandem meter yoke as shown on the standard detail. Prior to installation of the meter and connection to the building or house, the entire water service line and appurtenances shall be flushed.

### **3.09 Pressure Tests**

Where any section of a waterline is provided with concrete thrust blocking for fittings or hydrants, the pressure tests shall not be conducted until at least 48 hours after installation of the concrete thrust blocking, unless otherwise specified.

### **3.09.01 Pressure Test**

All labor, test equipment, water for testing; appurtenances and material, and performance of all operations in accordance with the specifications, are the responsibility of the Contractor.

All pipelines shall be tested for water tightness up to the individual service meter or domestic stop. The test equipment will not be provided, but is subject to inspection by the NTUA. Arrangements for water used in pipeline testing and payment for the water shall be coordinated with the local NTUA office. Pressure gauges used for pressure testing, shall be graduated at a maximum of 5-PSI increments. Two gauges will be used simultaneously for verification of the gauges functionality. Prior to the actual test, the pipeline shall be pressured to 10-PSI above the test pressure. The pressure will then be decreased to the test pressure, after the required time, so that gauge responsiveness can be observed.

The minimum test pressure shall be at least 160-PSI, measured at the lowest point of elevation in the test section. No section shall be tested that is greater than one mile in length or that has greater than 25-PSI pressure change, due to elevation. The test shall be conducted in such a manner that existing mains, services lines, and service user's plumbing are not damaged. Damage caused by testing shall be corrected at the expense of the Contractor. All connections, valves, blow-offs, hydrants, and house services up to the meter yoke shall be tested with the main, as far as are practicable. When testing piping systems designed to operate above 160-PSI, it will be tested as if it were rated at 160-PSI.

#### **No air testing shall be allowed.**

The test section shall be filled slowly with potable water and all air shall be vented from the line. The test shall not begin until the pipe has been filled with water for at least 24 hours to allow for absorption. The test shall have a minimum duration of two hours with the two-hour period beginning when the test pressure is attained and the pump ceases operation.

No pipe installed shall be accepted if the leakage is greater than that determined by the following formula:

$$Q = \frac{N \cdot D \cdot (P)^{1/2}}{7400}$$

in which,

Q = Allowable leakage in gallons per hour

N = Number of joints in the pipeline being tested, this "N" being the standard length of pipe furnished divided into the length being tested with no allowance for double gasket joint caused by use of couplings instead of integral bell pipe or for joints at branches, blow-offs, fittings, etc.

D = Nominal diameter of pipe in inches

P = The test pressure in PSI gauge as discussed in the third paragraph of this procedure.

During the test, the test pressure should not lose more than 5-PSIG without being pumped back up to the test pressure. The total of the gallons of water required to hold the test pressure during the two hours plus the amount of water required to return the line to the test pressure at the end of the two-hour test period is the total leakage. If the total leakage is less than the allowable leakage, the line can be accepted. All visible leaks will be repaired, regardless of the amount of leakage. Should the test on any section of the pipeline show leakage greater than the allowable leakage, the Contractor shall locate and repair the defective pipe, fitting, or joint until the leakage is within the allowable leakage for the two-hour test duration.

### **3.09.02 Observation of Tests**

The NTUA shall witness the pressure testing of waterlines. Prior to the actual test, the Contractor shall have all equipment set up completely, ready for operation and shall have previously successfully performed the test to verify that the test section will pass. The Contractor shall notify both the NTUA and the NMDOT a minimum of three working days in advance of the date that the Contractor plans to perform the pressure tests.

The NTUA shall observe the testing to verify that the testing was performed according to the specifications and that the test data were properly and accurately recorded. The Contractor shall complete the required certification forms and submit them to the NTUA for approval. A letter of approval or disapproval of the test results will be sent from the Operating Utility to the Contractor.



### **3.10 Disinfection**

A liquid chlorine solution shall be introduced continuously into one end of the system and allowed to flow along and through all lines and appurtenances to be disinfected until a minimum of 50-PPM of chlorine is detected at representative points throughout the line. A contact period of 24 hours shall be maintained before the system is flushed out with clean water until a maximum of 0.4-PPM chlorine residual is attained. All valves shall be operated several times during the 24-hour contact period.

After disinfection, the Contractor shall collect bacteriological samples for testing at his expense. A laboratory certified by the State Health Department or the U.S. Environmental Protection Agency shall perform the analysis. If an unsatisfactory bacteriological test result (positive result) is obtained, the system shall be disinfected and re-tested by the Contractor. This shall be repeated until a satisfactory bacteriological test (negative result) is obtained. Disinfection by introducing granular or tablet chlorine compounds in each pipe length is not an acceptable method of disinfection and will not be allowed.

**EXHIBIT A OF TP-3  
WATER LINE PRESSURE TEST CERTIFICATION**

LOCATION OF LINE TESTED: \_\_\_\_\_  
Include Project Name & Number

DATE(S) TEST WAS CONDUCTED: \_\_\_\_\_

GAUGES MANUFACTURER AND MODEL: 1) \_\_\_\_\_

2) \_\_\_\_\_

STANDARD LENGTH OF PIPE IN TEST SECTION: \_\_\_\_\_ FEET.

TEST SECTION: \_\_\_\_\_  
(Sta.-Sta., Line No., etc.)

Length (Sta.-Sta.) Time-Start/End	Line Size/Type (Inch)	Pipe Pressure Rating (PSI)	Test Pressures (PSIG)	Observed Pressure Range (PSIG)	Total Leakage (Gal./2hrs.)	Allowable Leakage (Gal./2hrs.)

THE TEST AND ATTACHED INFORMATION IS CERTIFIED BY:

Signature/Printed Name: \_\_\_\_\_

Organization/Address: \_\_\_\_\_

Address: \_\_\_\_\_

Telephone Number: \_\_\_\_\_

TEST RESULTS CHECKED AND APPROVED ON: \_\_\_\_\_  
Date

BY: \_\_\_\_\_ PASSED \_\_\_\_\_ FAILED \_\_\_\_\_  
NTUA Representative

COPY OF APPROVAL OF TEST SENT TO: \_\_\_\_\_

ON \_\_\_\_\_ BY \_\_\_\_\_  
Date Project Agency Involved  
NTUA

**EXHIBIT B OF TP-3**  
**WATER LINE PRESSURE TEST WORKSHEET 1**

Allowable Leakage:  $Q = \frac{ND(P)^{1/2}}{7400}$

Q = Gallon per Hour

N =  $\frac{\text{Total Length of Line Being Tested (ft)}}{\text{Standard Length of Pipe (ft)}} = \underline{\hspace{2cm}} = \underline{\hspace{2cm}}$

D = Nominal Diameter of Pipe (inches) =  $\underline{\hspace{2cm}}$

P = Test Pressure (psig) =  $\underline{\hspace{2cm}}$

Allowable Leakage (2 Hour Test) =  $2Q = \frac{ND(P)^{1/2}}{7400} \times 2 = \underline{\hspace{2cm}}$  (Gals.)

Are the pressure gauges graduated at a maximum of 5-PSI increments?  $\underline{\hspace{2cm}}$

Was the line pressured to 10 PSI above the test pressure so that the gauge responsiveness could be observed?  $\underline{\hspace{2cm}}$

Is the length of the test section less than one mile?  $\underline{\hspace{2cm}}$

Is the elevation difference between the highest and lowest points in the test section less than 57 feet?  $\underline{\hspace{2cm}}$

Are the pipes in the test section the same pressure rating?  $\underline{\hspace{2cm}}$

Description of Activity:	Time:	Gauge Readings:	Amount of Water Added:
Total Time:	Hrs.		Total: Gals.

Verified By:  $\underline{\hspace{2cm}}$   
 NTUA Representative/Date

$\underline{\hspace{2cm}}$   
 Print Name/Title

**EXHIBIT C OF TP-3**

**WATER LINE PRESSURE TEST WORKSHEET 2**

Test Section: \_\_\_\_\_  
(Sta-Sta, Line No., Etc.)

Length (Sta.-Sta.)  Time: Start & End	Line Size & Type  (Inch)	Pipe Pressure Rating  (PSI)	Test Pressure  (PSIG)	Observed Pressure Range  (PSIG)	Total Leakage  (Gal./2hrs.)	Allowable Leakage  (Gal./2hrs.)

## **TECHNICAL PROVISIONS 4.0**

### **TP 4.0 WASTEWATER MAINS AND APPURTENANCES**

#### **4.01 Scope of Work**

The work covered by this section includes the furnishing of all labor, equipment, and material; performing all operations in connection with the construction of gravity wastewater mains and service lines, including manholes and other appurtenances, in accordance with these technical provisions and applicable drawings.

#### **4.02 General**

The wastewater line shall be constructed in the location and to the grade and size shown on the drawings or as directed in writing by the NTUA. Excavation, trenching, and backfilling shall be in accordance with TP 1.0 of these specifications. Inspection of wastewater lines and manhole connections shall be accomplished before backfilling, but work covered by this section will not be accepted until backfilling has been completed satisfactorily. Any section of wastewater that is found defective in material, alignment, and/or grade shall be corrected to the satisfaction of the NTUA and the NMDOT.

#### **4.03 Materials**

##### **4.03.01 Polyvinyl Chloride (PVC) Wastewater Pipe**

Except for extensions to dead ends of 400 feet or less where 6-inch is permitted, minimum wastewater main pipe size and slope, shall be 8-inch nominal diameter at 0.4% slope; and minimum wastewater service pipe size shall be 4-inch nominal diameter at 2.0% slope. All PVC wastewater pipe shall be made of materials conforming to the requirements of ASTM-D1784, Type I, Grade I for Rigid Polyvinyl Chloride compounds. The PVC wastewater pipe shall be SDR 35, Type PSM, with elastomeric gasket joints and shall meet the requirements of ASTM-D3034. The pipe shall have an integral bell with a solid cross section rubber ring, which has been factory assembled and securely locked in place to prevent displacement. Standard lengths shall be 20 feet.

##### **4.03.02 Polyvinyl Chloride (PVC) Wastewater Pipe Fittings**

All PVC wastewater pipe fittings shall be SDR 35, Type PSM, with elastomeric gasket joints and shall meet the requirements of ASTM D-3034. Service connections to new wastewater mains shall be wye fittings. Connections to existing wastewater mains may be wye saddles.

#### **4.03.03 Ductile Iron Wastewater Pipe**

Ductile Iron Pipe shall meet the requirements of AWWA C151, with either mechanical or push-on joints, with an interior lining of 40-mil polyurethane or ceramic epoxy and an exterior of standard bituminous coating. Thickness shall be Class 52 in all sizes.

#### **4.03.04 Ductile Iron Wastewater Pipe Fittings**

Service connections to ductile iron pipe shall be via saddle-type fittings equal to the " or AOE. Connections between wastewater PVC pipe and ductile iron pipe shall be via the appropriate size Calder coupling; however, the ductile iron pipe should be extended from manhole to manhole to minimize the use of adapters.

#### **4.03.05 Pre-cast Concrete Manhole Sections**

Manhole sections shall conform to ASTM C 478. A polyisoprene rubber connector meeting the material and performance requirements of ASTM C-923 and equal to the "A-Lok" Connector as manufactured by A-Lok Products Inc., Trenton, N.J., shall be used to seal between the pre-cast manhole and the sewer pipe. "Ram-Nek" flexible gasket or the "Butyl-Lok" preformed sealant tape by A-Lok Products, Inc., or an approved equal shall be used to seal between manhole sections, grade rings, and cover ring. Bottom manhole sections shall have integral pre-cast base or reinforced concrete floor slabs.

#### **4.03.06 Manhole Covers and Frames**

The frames and covers shall be cast iron, equivalent to a Deeter 1257, 330 pounds, with a Type C surface pick slot. The cover minimum opening shall be 24-inches in diameter with a 6-inch high ring. The lid shall not have any holes including pick holes, which penetrate the entire thickness of the lid. A  $\frac{3}{4}$ "-inch by 2-inch by 2-inch recessed slot with a  $\frac{1}{2}$ -inch diameter pin, crossing the small dimension and centered along the long dimension, shall be provided in the lid, in lieu of a pick hole.

#### **4.03.07 Manhole Steps**

Manhole steps shall be made of  $\frac{1}{2}$ -inch steel rod encapsulated with copolymer polypropylene or approved equal and shall conform to ASTM C478. The ALCO 12653A aluminum step is also acceptable. Steps shall have minimum projections of 4-inches, spaced no more than 16-inches apart, minimum overall widths of 14-inches, and thoroughly anchored into the walls.

#### **4.03.08 Concrete**

All concrete in addition to the concrete used in precast sections shall have a compressive strength of not less than 3,000 pounds per square inch at 28 days of age. The aggregates, Portland cement, and concrete shall comply with the provisions of ASTM C144 and C33, ASTM C150, Type II. The concrete mix shall be approved by the Owner and shall include no less than 5-1/2 bags of Portland cement per cubic yard. When directed by the Owner, the Contractor shall have compressive strength tests made of the concrete in accordance with ASTM Standard Specifications.

#### **4.03.09 Wastewater Cleanout and Frame**

Where required on the plans, a Neenah R1791A or approved equal cast iron cleanout cover and frame shall be used on all 8-inch wastewater cleanouts.

### **4.04 Installation of Wastewater Pipe**

#### **4.04.01 Pipe Laying**

All trenching, excavation, and backfilling shall be performed in accordance with TP 1.0 of these specifications. The bottom of the trench shall be shaped to give substantial uniform bearing and support for each section for the entire length of the pipe. Bell holes shall be excavated to provide a minimum clearance of 2 inches below the coupling or bell. Pipe laying shall proceed upgrade, with the spigot end pointing in the direction of the flow. Each pipe shall be laid true to line and grade and in such manner as to form a close concentric joint with the adjoining pipe. As the work progresses, the interior of the sewer shall be cleared of all dirt and superfluous materials of every description. If the maximum width of the trench at the top of the pipe specified in TP 1.0 of these specifications is exceeded for any reason other than by direction, the Contractor shall install such concrete cradling, encasement, gravel base or other bedding as may be required to satisfactorily support the added load of the backfill.

Trenches shall be kept free from water and the pipe shall not be laid when conditions of the trench or the weather are unsuitable for such work. At all times when work is not in progress, all open ends of pipe and fittings shall be securely closed so that no trench water, earth, or other substances will enter the pipe.

#### **4.04.02 Depth of Bury**

All sewage collection lines shall be ductile iron if less than 3 feet of cover is provided within streets and less than 2 feet of cover is provided in all other areas.

#### **4.04.03 Installation of Service Connections**

Wye fittings shall be provided and installed for sewer service connections to new sewer mains. Service saddles are not appropriate for service connections to newly constructed sewer mains but may be used for connections to existing sewer mains. The wye shall be installed such that it is at about a 45-degree angle with the vertical.

### **4.05 Manhole Installation**

#### **4.05.01 General**

Manholes shall be installed in the locations shown on the plans and shall be constructed in accordance with the standard details. Manholes shall be spaced no more than 400 feet apart, and shall be installed at every change in grade, pipe size, or direction.

The invert channel shall be smooth and U-shaped. The lower portion shall conform to the inside of the adjacent sewer section and the upper portion shall be greater in height than the diameter of the largest pipe. A minimum invert elevation drop of 1/10 of a foot from the entrance to the outlet shall be provided in all manholes where there is a change in direction or grade. Changes in size and grade of the channel shall be made gradually and evenly. The invert channel may be formed directly in the concrete, or where there is no change in grade or direction between incoming and outgoing sewers, may be constructed by laying a full section of sewer pipe through the manhole and cutting out the top half after the surrounding concrete has hardened.

The floor of the manhole outside the channel shall be smooth and shall slope toward the channel not less than one inch per foot and not more than 2-inches per foot. Drop inside the manhole shall not exceed 2 feet, measured from the invert of the inlet pipe to the invert of its corresponding channel. If the drop exceeds 2 feet, then a drop manhole shall be installed. A channel must be formed in the concrete of an ogee shape so there is no free drop. Joints between manhole sections, adjustment rings, and cover rings shall be sealed with Ram-Nek flexible gasket or approved equal; and a concrete collar shall be installed in accordance with the standard details.



All sewers extending from manholes shall be supported with compacted gravel from where the sewer pipe leaves the manhole to where the pipe is supported by undisturbed soil.

#### **4.05.02 Connection to Existing Manhole**

The Contractor shall obtain a tapping permit from the NTUA prior to making connections to existing manholes. The connection to the existing manhole shall be made in accordance with the approved plans. Care should be exercised when connecting to the existing manhole so that limited fracture and cracking will occur on the existing manhole. Also, placement of the new wastewater main should be correctly aligned to the invert elevation so as to allow for proper flow of sewage through the manhole. Excessive damage to the existing manhole or improper installation of the new wastewater main, as determined by the NTUA, shall be cause for replacement of the existing facilities within the construction area by the Contractor. This replacement shall be done to the satisfaction of the NTUA and NMDOT.

#### **4.06 Wastewater Main Crossings**

##### **4.06.01 Wash Crossings**

Wastewater mains shall be installed as shown on the approved plans. The Contractor shall divert surface flows, conduct dewatering, and perform all steps necessary to maintain proper bedding conditions and alignment.

##### **4.06.02 Road Crossings**

In lieu of boring, the roadway may be open cut for sewer line within casing installation. The original surface pavement on all open cut roadways shall be either cut square or sawed straight. As with open cut, if boring is required, the steel casing shall be extended from right of way to right of way. The Contractor shall obtain written permission from the appropriate agency prior to beginning any roadway excavation. Backfill within the limits of a roadway prism may require special compaction in accordance with the roadway crossing permits.

Surfacing shall be replaced where the roadway has gravel, concrete, or asphaltic paving in the same thicknesses as were removed, or as specified by the Owner, and completed as soon as possible following backfilling.

PVC wastewater line road crossings shall be installed within steel casing on acceptable casing chocks or redwood skids secured to the pipe

with stainless steel straps. Ductile Iron pipe resting on the bells also may be used as the carrier pipes. The casing ends shall be sealed with an approved rubber boot or 9 mil plastic sheeting with stainless steel clamps. Casing pipe shall be straight welded SCH 10 steel pipe 1/4" wall unless otherwise specified. An alternative method for roadway crossing is to install ductile iron pipe, Class 52, bell and spigot, direct bury by open cut excavation from right of way to right of way. This would be considered when crossing minor roads or trails, or for congested area within an urban setting.

A manhole shall be installed on each side of the roadway right of way, unless specified otherwise. The minimum grade of all road crossings should be 1.0% unless exempted by the NTUA and the NMDOT.

#### **4.07 Sewer Service Line Installations (Not part of the Utility company's facilities)**

##### **4.07.01 General**

All trenching, excavating, and backfilling should be performed in accordance with TP 1.0 and TP 2.0 of these specifications. All new construction shall provide a minimum slope of 1/4-inch per foot (2%) and maintain at least 2 feet of cover over the line. Clean outs should be placed at the house, at any in-line bend greater than 45 degree, and at 100-foot intervals. Bends greater than 45 degrees are discouraged. Services should not enter a manhole but should enter the main line at least 10 feet either side of the manhole.

##### **4.07.02 Connection to Wyes or Main**

Sewer service lines should be connected to the sewer wyes provided with the new sewer main. If connecting to an existing main without existing wyes, the connections shall be made with wye saddles. The Contractor shall obtain from the Operating Utility tapping permits before making sewer service connections to existing sewer mains. The saddle shall be aligned on the sewer main such that it is at about a 45 degree angle with vertical and in no case shall deviate, by more than 15 degrees from either side of 45 degrees without prior approval. During the installation of the sewer saddle, the Contractor shall not allow the pipe cutout or other foreign objects to enter the sewage collection system.

#### **4.08 Wastewater Line Testing**

##### **4.08.01 Alignment Test**

The Contractor shall notify the NTUA two working days in advance of

the date that the Contractor is ready for inspection of sewer alignment. The wastewater main shall be checked by the Contractor and verified by the NTUA, to determine whether any displacement of the pipe has occurred, after the trench has been backfilled to 2 feet above the pipe and tamped as specified. The test shall be made as follows: A light shall be flashed between ends of line by means of a flash light or reflected light. Any deviation from true line or grade, causing less than a full lamped circle, may be cause for rejection. Any ponding of water in the wastewater line may be cause for rejection. A full lamp circle is when a full circle of light is seen from any position around the pipe perimeter.

#### **4.08.02 Deflection Test**

The maximum allowable deflection (reduction in vertical inside diameter) for PVC pipe shall be five percent. Deflection testing may not be required in all cases; however, the NTUA reserves the right to require the Contractor to perform random deflection tests. If three successive tests are determined to be unsatisfactory, the Contractor shall perform deflection tests on the entire project. All locations with excessive deflection shall be excavated and repaired by re-bedding or replacement of pipe. Acceptable methods of deflection testing include use of properly sized go-no-go mandrels or other proposals suitable to the operating utility.

#### **4.08.03 Ex-filtration Test**

The Contractor shall conduct an ex-filtration test on each section of wastewater mains between manholes. The Contractor shall provide at his own expense all necessary equipment and materials required for the tests. One of the following testing methods shall be used.

Air Testing: Testing equipment shall be equal to the “Air-Loc” low pressure air testing system manufactured by Cherne Industrial, Inc. of Edina Minnesota. The gauge used for the air test shall have a minimum division of 0.10-PSI.

Testing shall be conducted in accordance with ASTM C924 (Testing Sewer Lines by the Low-Pressure Air Test Method), except as modified herein. Air testing shall be done between consecutive manholes throughout the entire length of the installed line. Air shall be added to the plugged test section until the internal air pressure reaches 4.0 psig. At least two minutes shall be allowed for the air pressure to stabilize. The air supply shall then be disconnected and the time required for the pressure to drop from 3.5 to 3.0 psig shall be measured with a stopwatch. No one shall enter a manhole when a line into it is

pressurized. If the groundwater level is above any portion of the test section, the test pressure shall be increased, by an amount equal to the average hydrostatic pressure of the groundwater.

The test section will be accepted if the time required for the pressure to decrease from 3.5 to 3.0 PSIG is equal to or greater than the time in the following table. The pipe diameter shall be based on the nominal size of the sewer main. If the time measured is less than the time specified in the table, the Contractor shall locate and repair any leaks and retest the sewer until it is acceptable.

Minimum Duration for Pressure Drop (400 feet Max.)	
Pipe Diameter (Inches)	Time (Minutes)
4	2.5
6	4.0
8	5.0
10	6.5
12	7.5

The following formula should be utilized to determine the minimum duration for pressure drop for test sections greater than 400 feet or pipe sizes greater than 12 inches.

$$T = 0.000371 \cdot D^2 \cdot L \div 2$$

Where: T = Time in Minutes  
 D = Nominal Diameter in Inches  
 L = Pipe Length in Feet

Water Testing: One gallon of water may be lost in 2 hours, per each section between manholes, when testing any size main up to 12-inches. The line shall not be tested with the manhole. At least 4 feet of head shall be used for the test. Service lines need not be tested, but they must be plugged to conduct the test of the main. If any leakage in excess of the allowable occurs in any section of the sewerline, that section(s) shall be repaired and re-tested after the leaks are located.

**4.08.04 Groundwater Infiltration**

Infiltration of groundwater in excess of 200 gallons per day per inch diameter per mile of wastewater line indicates that the line is not

watertight. Infiltration less than this amount does not relieve the Contractor of the requirement to perform ex-filtration testing. If excess infiltration is noted after ex-filtration tests have been completed, it shall be considered as evidence that the original test was in error or that subsequent failure of the pipeline has occurred.

#### **4.09 Manhole Testing**

Manholes shall be tested for water tightness. Each manhole shall be tested by itself. All lift holes shall be plugged with an approved non-shrink grout. All mains into and out of the manhole shall be plugged with a suitable device. If the manhole fails the initial test, necessary repairs shall be made and the manhole shall be retested. One of the following methods shall be used.

Vacuum Testing: Vacuum testing should be conducted, in accordance with ASTM C1244 (Vacuum Test for Concrete Manholes), except as modified below. The vacuum test head shall be placed inside the top section and the seal inflated in accordance with the manufacturers' recommendations. A vacuum of 10-inches of mercury shall be drawn and the vacuum pump shut off. With the valves closed, the time shall be measured for the vacuum to drop to 9-inches. The manhole shall pass if the time is greater than 60 seconds for 48-inches diameter, 75 seconds for 60-inches, and 90 seconds for 72-inches diameter manholes.

Hydrostatic Testing: Hydrostatic testing shall be conducted in accordance with ASTM C969, except as modified below. The manhole shall be filled with water to the ring. The maximum loss shall be 5 gallons in a 2-hour test regardless of the manhole depth. The amount of loss shall be determined by measuring the volume of water required to maintain the water level in the manhole within 2-inches of the top of the cone or flat top throughout the entire duration of the 2-hour test.

#### **4.10 Observation of Pressure Tests**

The NTUA is to witness the pressure testing of wastewater lines and manholes. Prior to the test, the Contractor shall have all equipment set up, completely ready for operation and shall have previously successfully performed the test to verify that the test section or manhole will pass. The Contractor shall notify both the NTUA and the NMDOT, a minimum of two working days in advance of the date that the Contractor plans to perform the pressure tests. The Contractor will complete the required certification forms and submit them to the NTUA for approval. A copy of the approval or disapproval of the test results will be sent from the NTUA to the Contractor (see "Exhibit A & C of TP-4).

**EXHIBIT A OF TP 4.0**

**WASTEWATER MAINLINE/MANHOLE WATER TEST 1 CERTIFICATION**

LOCATION OF LINE TESTED: \_\_\_\_\_  
Include Project's Name & Number

DATE(S) TEST WAS CONDUCTED: \_\_\_\_\_

STANDARD LENGTH OF PIPE IN TEST SECTION: \_\_\_\_\_ FEET.

THE TEST AND INFORMATION IS CERTIFIED BY:

Signature/Printed Name: \_\_\_\_\_

Organization/Address: \_\_\_\_\_

Address: \_\_\_\_\_

Telephone Number: \_\_\_\_\_

WASTEWATER TEST 1 RESULTS CHECKED AND APPROVED ON: \_\_\_\_\_  
Date

BY: \_\_\_\_\_  
NTUA Representative

PASSED \_\_\_\_\_ FAILED \_\_\_\_\_

COPY OF APPROVAL OF THE TEST SENT TO: \_\_\_\_\_  
Project Agency Involved

ON \_\_\_\_\_ BY \_\_\_\_\_  
Date NTUA

**EXHIBIT B OF TP 4.0**

**WASTEWATER MAINLINE/MANHOLE WATER TEST 1-WORKSHEET**

LOCATION OF LINE TESTED: \_\_\_\_\_  
Include Project Name & Number

DATE(S) TEST WAS CONDUCTED: \_\_\_\_\_

(Allowable Leakage: 1 gal/section/2 hrs. for 8" PVC to 12" PVC, regardless of length, using 4-feet of head test pressure.)

**SEWER MAIN**

Sewer Main (MH# to MH#)	Size (in)	Length (ft.)	Actual Leakage (gal.)	Pass/Fail (P or F)	Remarks

Verified By: \_\_\_\_\_  
NTUA Representative/Date

\_\_\_\_\_  
Print Name/Title

(Allowable Ex-filtration: 5 gal./MH/2 hrs. regardless of height. Lamp testing shall be conducted at completion of final grading.)

**SEWER MANHOLE**

Manhole No.	Station	Actual Leakage (gal.)	Pass/Fail (P or F)	Remarks

Verified By: \_\_\_\_\_  
NTUA Representative/Date

\_\_\_\_\_  
Print Name/Title

**EXHIBIT C OF TP 4.0**

**WASTEWATER MAINLINE/MANHOLE AIR/VACUUM TEST 2 CERTIFICATION**

LOCATION OF LINE TESTED: \_\_\_\_\_  
Include Project Name & Number

DATE(S) TEST WAS CONDUCTED: \_\_\_\_\_

THE GAUGE USED FOR TESTING SHALL HAVE MIN. DIVISION OF 0.10 PSI.

STANDARD LENGTH OF PIPE USED ON THIS PROJECT IS \_\_\_\_\_ FEET.

THE TEST AND ATTACHED INFORMATION IS CERTIFIED BY:

Signature/Printed Name: \_\_\_\_\_

Organization/Address: \_\_\_\_\_

Address: \_\_\_\_\_

Telephone Number: \_\_\_\_\_

WASTEWATER TEST 2 RESULTS CHECKED AND APPROVED ON: \_\_\_\_\_  
Date

BY: \_\_\_\_\_  
NTUA Representative

PASSED \_\_\_\_\_ FAILED \_\_\_\_\_

COPY OF APPROVAL OF THE TEST SENT TO: \_\_\_\_\_  
Project Agency Involved

ON \_\_\_\_\_ BY \_\_\_\_\_  
Date NTUA



**EXHIBIT D OF TP 4.0**

**WASTEWATER MAINLINE/MANHOLE AIR/VACUUM TEST 2 WORKSHEET**

LOCATION OF LINE TESTED: \_\_\_\_\_  
 Include Project's Name & Number

DATE(S) TEST WAS CONDUCTED: \_\_\_\_\_

Air testing shall be conducted between consecutive manholes. The test section shall be acceptable if the time required for the pressure to drop from 3.5 to 3.0 PSIG is greater than or equal to the time in the "Minimum Duration for Pressure Drop" table of TP-4.08.03.

**SEWER MAIN AIR TEST**

Sewer Main MH# to MH#	Size (in.)	Length (ft.)	Start Test Pressure (Psig)	Stop Test Pressure (Psig)	Elapsed Time (Min/Sec.)	Pass/Fail (P or F)	Remarks

Verified By: \_\_\_\_\_ Date: \_\_\_\_\_

Title/Company: \_\_\_\_\_

Manhole shall pass if time is greater than 60 seconds for 48" Dia. MH, 75 seconds for 60" Dia. MH, and 90 seconds for 72" Dia. MH.

**MANHOLE VACUUM TEST**

Manhole No.	Station	Start Vacuum of 10" of Mercury (Inch)	Stop Vacuum (Inch)	Elapsed Time (Min/Sec.)	Pass/Fail (P or F)	Remarks

Verified By: \_\_\_\_\_ Date: \_\_\_\_\_

Title/Company: \_\_\_\_\_

\* Lamp test shall be conducted after completion of street construction and final grading.

**TP 4.11 Individual Subsurface Disposal Systems (Not part of the Utility Company's Facilities)**

**4.11.01 General**

The Contractor shall install individual subsurface disposal systems at the locations shown on the plans. The work shall consist of furnishing and installing a double compartment 1,000-gallon or larger septic tank, 4-inch sewer pipe, and leachfield system in accordance with these technical provisions and applicable drawings. All construction will be done in a workmanlike manner. All sites will be left with a neat appearance.

**4.11.02 Septic Tanks**

**4.11.02.01 General**

All septic tanks shall have a minimum liquid capacity of 1,000 gallons and double compartment. Liquid capacity shall be split with two-thirds in the first compartment and one-third in the second compartment. The liquid depth of the septic tanks shall be at least 4 feet but not more than 5 feet.

The inlet and outlet on all tanks shall be provided with vertical tee fittings of cast iron or PVC plastic. In concrete tanks, oval box shaped or slab type baffles of pre-cast reinforced concrete with a minimum thickness of 2-inches may be used. The inlet baffle or tee must penetrate at least 5-inches below the liquid level but in no case shall it be greater than the penetration of the outlet baffle or tee. Both inlet and outlet baffles or tees shall extend 6-inches or more above the liquid level and end 1-inch from the underside of the tank top to allow gases to escape. The outlet baffle or tee shall extend below liquid level 40 percent of the liquid depth for rectangular tanks and 35 percent for circular tanks. The common wall passage shall also be located at the 40 percent liquid level depth. The inlet invert should be at least 2-inches above the liquid level in the septic tank. Four copies of drawings indicating pertinent dimensions, type, and location of steel reinforcing in concrete tanks, and important details shall be submitted by the Contractor for approval by the Owner prior to the installation of any septic tank.

**4.11.02.02 Concrete Tanks**

Concrete septic tanks shall be of pre-cast, mechanically vibrated, 4,000 psi minimum strength, watertight concrete containing adequate steel reinforcement to facilitate handling. Minimum wall thickness shall be 3-inches. The top and bottom shall have a minimum

thickness of 4-inches. Minimum steel reinforcement will be No. 3 reinforcing bars spaced 2 feet on centers in both directions in the top, bottom, and sides. The equivalent shall be used around manhole inspection ports and construction joints. Minimum steel reinforcement of the access cover or lid shall be No. 4 rebar spaced 6-inches on center in both direction or equivalent. The manhole and inspection opening covers shall be provided with steel lifting handles of No. 3 or No. 4 rebar.

Tanks shall be free of cracks from casting or handling (including placement). No wire mesh or rebar shall be exposed at any point on the tank interior or exterior.

Adequate access shall be provided into the septic tank either through a removable section or manhole with a minimum of 20-inches in the least dimension. The access manhole may be placed partially over the inlet to serve as an inspection hole; otherwise, inspection openings with a minimum of 7-inches in the least dimension shall be provided above the inlet, outlet, and the inter-compartment piping. The access manhole shall be provided with a 6-inch PVC coupling that extends through the center. A 6-inch diameter inspection pipe shall be installed so that it is connected to the access manhole coupling and extends to a point 12-inches above the ground surface. The pipe shall be 160 psi, SDR 26, PVC, shall terminate above ground surface with a 6-inch slip joint PVC cap, and shall be painted red on those portions above the ground surface.

#### **4.11.03 Septic Tank Installation**

Excavation shall be approximately 1 foot wider and longer than the tank. All tanks shall be set on a smooth level surface. The septic tank shall be placed plumb and true so that the inlet and outlet are at the highest possible elevations and so that the outlet pipe is not less than 2-inches nor more than 5-inches below the inlet pipe. The minimum bury for the septic tank inlet pipe shall be 18-inches. The maximum dirt cover for the septic tank shall be 36-inches. Where over excavation occurs, the bottom shall be raised to final elevation in 6-inch compacted lifts. Any water in the excavation must be removed and elevations checked before setting the tank. After setting the tank, it shall be filled with water to prevent floating. Both the septic tank inlet and outlet lines shall be grouted to the septic tank. Backfill around the tank shall be compacted and shall be sufficient to allow for no settlement.

#### **4.11.04 Sewer Pipe and Fittings**

All 4-inch pipe and fittings, except clean out tees, risers, hub adapters, and plugs, shall be PVC, SDR 35, solvent-weld joints and shall comply with ASTM

Specifications D-3033 and D-3034. All PVC shall be Type 1, Grade 1, PVC 1140 conforming to ASTM Specification D-1784.

Cleanout tees, risers, hub adapters, and plugs shall be PVC/DWV and comply with ASTM Specification D-2665.

#### **4.11.05 Sewer Pipe Installation**

All trenching, excavating, and backfilling shall be performed in accordance with TP 1.0 of these specifications. All construction shall provide a slope of 1/4" per foot (2%) and maintain at least 18-inches of cover over the line between the house and the septic tank. A minimum cover of 12-inches is required between the septic tank and drainfield system. Cleanout tees shall be two-way, 4" x 4" x 4", all solvent-weld hubs, PVC/DWV fittings. Cleanout risers for DWV cleanout shall be 4-inch PVC/DWV and shall terminate 3 to 6-inches above the ground surface with a PVC/DWV 4-inch hub adapter (solvent-weld hub by FIPT) and MIPT plug. Cleanout shall be placed at the house and at any in-line bends greater than 45 degree (bends greater than 45 degrees are discouraged) and at 100 feet intervals.

#### **4.11.06 Drainfield Materials**

##### **4.11.06.01 Gravel**

Drainfield gravel shall comply with the requirements for coarse aggregate under Federal Specification SS-A-281b, "Aggregate; (for Portland-Cement-Concrete)", and shall be Size 3 (2" to 1" nominal size). The amount of deleterious substances in the coarse aggregate shall not exceed the limits given in Section 3.2.3 of Federal Specification SS-A-281b.

##### **4.11.06.02 Pipe and Fittings**

All PVC shall be Type 1, Grade 1, PVC 1140 conforming to ASTM Specification D-1784. All 4-inch solid PVC pipe and fittings shall be PVC, SDR 35, solvent-weld joints and shall comply with ASTM Specifications D-3033 and D-3034. All 4-inch perforated PVC pipe shall be solvent-weld joints and shall comply with ASTM Specification D-2729 or D-3033 and D-3034. Perforations shall be 1/2 to 5/8 inch diameter holes on 5-inch centers in two rows spaced 90 to 120 degrees apart.

##### **4.11.06.03 Drainage Fabric**

The drainfield fabric shall be non-woven and composed of polypropylene filaments and shall be inert to biological degradation

and naturally encountered chemicals, alkalies, and acids. The fabric shall have a minimum average grab tensile strength of 120 pounds, a minimum average burst strength of 285 psi, a minimum average coefficient of permeability of 0.3 cm/sec, and a minimum thickness of 60 mils. The drainage fabric shall be equal to the Mirafi 140N non-woven fabric as manufactured by Mirafi, Inc., P.O. Box 240967, Charlotte, North Carolina.

#### **4.11.07 Drainfield Installation**

The trench width in the drainfield shall normally be 24-inches and shall not exceed 36-inches nor be less than 12-inches without the consent of the Owner. Trench bottoms shall be smooth and level from beginning of trench to end. All smeared or compacted surfaces of the trenches or bed shall be raked to expose the natural texture of the soil. All loose material shall be removed from the trench before the gravel is placed. The drainfield trench shall be kept as shallow as possible but with a minimum depth of 24-inches and a maximum depth of 60-inches. Drainfields shall be built so that all lines are looped. Where rock, clay, or ground water are encountered, the Contractor shall immediately notify the Owner and shall cease work on the drainfield installation. The bottom of the trench shall be covered with a 6-inch minimum depth lift of gravel. The lift shall be leveled (but not compacted) by hand to within  $\pm$  1-inch throughout the entire length of the trench. The 4-inch perforated plastic pipe shall then be laid level  $\pm$  1-inch by hand and centered in the trench. After the pipe has been laid, a second 6-inch lift of gravel shall be placed by hand and not compacted. The gravel shall be placed so that it extends 2-inches above the pipe. A layer of synthetic drainage fabric then shall be placed over the gravel and folded up the sides of the trench to prevent backfill soil from coming in contact with the gravel.

The trench shall then be backfilled and not compacted. The top shall then be mounded with a 8 to 12-inch crown and shall not be compacted. No mechanical or vehicular traffic shall be used to compact the trench. Backhoes shall not be allowed on trenches during or after the backfilling operation.

Four, red T-type, steel posts shall be placed at the outside corners of the drainfield. The post shall be driven a minimum of 14-inches into the ground and shall extend a minimum of 36-inches above the ground. The Contractor shall leave the premises in a neat and orderly condition. Excess dirt shall be spread evenly over the ground in the immediate area or disposed of in a manner approved by the Owner.

#### **4.11.08 Gravel-less Drainfield Materials**

The gravel-less drainfield shall consist of interlocking leaching chamber units, opened end plates, and closed end plates constructed from molded high density polyethylene. Gravel-less drainfield components shall be equal to the Infiltrator

as manufactured by Infiltrator Systems Inc., P.O. Box 768, Old Saybrook, CT 06475, or an approved equal.

#### **4.11.09 Gravel-less Drainfield Installation**

In place of perforated pipe and gravel for distribution and storage of waste water, leaching chambers or gravel-less drainfield systems can be employed.

The trench width for a gravel-less drainfield shall normally be 36-inches or as specified by the supplier of system. Trench bottoms shall be smooth and level from beginning of trench to end. All smeared or compacted surfaces of the trenches or bed shall be raked to expose the natural texture of the soil. All loose material shall be removed from the trench before the chamber units are installed. The trench shall be kept as shallow as possible but with a minimum depth of 24-inches and a maximum depth of 36-inches.

The installation of the gravel-less system shall be per the manufacturer's recommendations. Where rock, clay, or ground water are encountered, the Contractor shall immediately notify the Owner and shall cease work on the drainfield installation. The area between the leach chamber and trench wall shall be backfilled and compacted. The minimum cover for the gravel-less drainfield is 12-inches. The top shall then be mounded with an 8 to 12-inch crown and shall not be compacted. No mechanical or vehicular traffic shall be used to compact the trench. Backhoes shall not be allowed on trenches during or after the backfilling operation.

A 4-inch solid sewer PVC-DWV inspection port with adapter hub and plug shall be installed at the end of each line. The Contractor shall leave the premises in a neat and orderly condition. Excess dirt shall be spread evenly over the ground in the immediate area or disposed of in a manner approved by the Owner.

## **TECHNICAL PROVISIONS 5.0**

### **TP 5.0 FINAL SITE UTILITY INSPECTION REQUIREMENTS**

#### **5.01 Final Inspection Package**

The Contractor shall submit a complete site utility inspection package, which shall include the following items; all copies of which shall be legible.

##### **5.01.01 As-Built Drawings**

Four (4) sets of Size D "as-built" drawings which contain:

- A. Cover Sheet
- B. Rights of Way Plat Sheets
- C. Utility Plan View Sheets
- D. Water/Wastewater Plan and Profile Construction Sheets
- E. Details Sheets - Standard and Specific Drawings

##### **5.01.02 As-Built Notebook**

Four (4) three ring, loose-leaf binders, containing the following information:

- A. Water Pressure Test Certification and Test Results Approved by the NTUA. See "Exhibit A" of TP-3.
- B. Wastewater Main and Manhole Test Certifications and Test Results Approved by the NTUA. See "Exhibit A" or "Exhibit C" of TP-4
- C. Executed Transfer Agreement with Cost of Plant attached. See Exhibit "A" and "B" of TP-5.
- D. Water Meter Serial Number Listing and Current Meter Readings.
- E. Approved Tapping Permits.
- F. Approved Water/Wastewater Material Submittals.
- G. A set of plans on CD in the AutoCAD version specified.

#### **5.02 Scheduling Final Inspection**

The scheduling for the final inspection shall be coordinated with the NTUA by the Contractor. A complete as-built package is to be provided to the NTUA for review, a minimum of 21 calendar days prior to the scheduled inspection.

### **5.03 As-Built Drawing Requirements**

Each project site that contains utilities to be transferred to the NTUA must be submitted with the following requirements and sheets.

#### **5.03.01 General Requirements for All Sheets**

**5.03.01.01** Each sheet must be stamped by an A/E\* and prominently labeled, signed, and dated by the Contractor (excepting cover and rights of way sheets):

AS BUILT \_\_\_\_\_  
(Name) (Date)

“I certify that I have constructed this project following the standards set forth in TPs 1 - 4, and I have complied with all vertical and horizontal pipeline separation requirements.”

**5.03.01.02** All facilities shall be shown as constructed and references to "proposed" or "future" deleted.

**5.03.01.03** Where appropriate, each sheet must have a north arrow. Whenever possible, the arrow shall be up or to the right of the sheet.

**5.03.01.04** Where appropriate, each sheet must have a standard legend and bar scale. All existing mains must be solid lines and sewer manholes must be solid circles.

**5.03.01.05** All sheets must be numbered sequentially beginning with “Sheet 1 of (Total) Sheets.”

#### **5.03.02 Cover Sheet**

**5.03.02.01** Since drawings occasionally cover several project sites, the location for each as-built site must be prominently identified by project number and project site location.

**5.03.02.02** A map of the Navajo Nation that shows the project location, a vicinity map with a scale of 1" = 2 miles, and a north arrow is to be provided. These maps may be on a separate sheet or on the topographic boundary sheet.

**5.03.02.03** The project site location, with the project number(s), should be shown on both the Navajo Nation and vicinity maps.



### **5.03.03 Plat Sheet**

**5.03.03.01** Show site boundaries with bearings and distances, complete with ties to permanent state plane markers (Section Corners, established monuments, etc.) and bearing references. All bearings shall be in the appropriate State Plane System in NAD 83 if possible; all distances shall be ground distances. Indicate basis of bearing.

**5.03.03.02** Show and describe location of elevation and vertical datum references. A broken line may be utilized if the benchmark is not within the drawing scope or scale.

**5.03.03.03** Show each lot and street boundary defined with bearings and distances, if appropriate. Show street centerline bearing, distance, and curve data.

**5.03.03.04** Provide statements "Street Rights of Way are Dedicated to the Common Use of Utilities" if appropriate, and "the operating utility is not responsible for the repair or replacements of improvements in utility easements disturbed during operation and maintenance activities."

**5.03.03.05** Show minimum 20-foot wide easements for each utility (electric, natural gas, water, sewers, telephones, cable) not located within the street right of way. Add an additional 10-foot width for each additional parallel utility. The NTUA will provide to the Contractor as-built drawings of utilities not constructed by the Contractor.

**5.03.03.06** Utility or street rights of way may require expansion in localized areas to include all utility appurtenances (e.g., fire hydrant guards), which are not within the normal easement.

**5.03.03.07** Provide a narrative legal description of the site boundary.

### **5.03.04 Utility Plan View Sheet(s)**

**5.03.04.01** On a sheet with a scale between 1"=20' and 1"=50', provide a plan view of the site that shows all utilities (e.g., propane, water, sewers, electric, natural gas, telephones, cable).

**5.03.04.02** Show all lot, street, and easement boundary lines without bearing and distances.

**5.03.04.03** Label all houses with final house numbers. Numbers must be

consistent with a swing tie table.

**5.03.04.04** Provide a legend, north arrow, and bar scale.

**5.03.04.05** Show as-built routing of all water and sewer mains and service lines. Emphasize water and sewer mains by using bolder lines. Use a smaller but bold line for service lines. Reference the standard NTUA legend.

**5.03.04.06** Label water mains with size, type of material, pressure rating, and length of pipe from P.I. to P.I. Example: 6" PVC, SDR 21, 232.00'.

**5.03.04.07** Label wastewater mains with size, type of material, and distances between manholes. Example: 8" PVC, SDR 35, 389.00'.

**5.03.04.08** Label water and wastewater main tap points, to previous projects with previous project number and as-built sheet number. Contractor shall contact the Operating Utility to determine this information.

Examples: White Cone Composite	Red Water Housing
IHS NA 88-114	NHA AZ 12-106
Sheet 15 of 43	Sheet C-8

**5.03.04.09** Show and label depth of bury at all locations where water main varies from the standard depth of bury of 42 inches.

**5.03.04.10** For fire hydrants, gate valves, tees, bends, water meters, curb stops, and saddles state the manufacturer model number and type of joint for the actual item used. As an option this information can be shown on the standard detail sheet next to the appropriate detail, or include submittals.

**5.03.04.11** Show and label all water main fittings actually used. G.V., 6" DI TEE, 6" DI 45° BEND. Examples: 6" G.V., 6" DI TEE, 6" DI 45° BEND.

**5.03.04.12** Provide swing ties in table format for all gate valves, water meters, domestic stops, curb stops, water main taps, manholes, main line clean out, yard clean outs, and sewer wyes. Swing ties shall be measured from building corners or other permanent structures.

**SWING TIES (Examples)**

House No.	Domestic Stop		Water Meter		Curb Stop		Water Main Tap		Yard Clean out		Sewer Wye	
	A	B	A	B	A	B	A	C	A	B	A	C
1	31.6	3.8	34.8	32.9	36.7	35.8	42.0	65.0	22.4	11.6	57.0	73.0

Item	House No.	Distance	
		A	B
MH 11A-3	3	56.2	68.4
GV-1	5	43.4	63.6
GV-2	5	43.6	61.6
MH 11A-1-2	15	93.4	73.0
CO-2	14	64.8	61.5

**5.03.04.13** Label corners of each building or structure, as necessary, to provide references for swing tie tables.



**5.03.04.14.1** Provide pipe information for each size and type of pipe in a table with the following format:

Use	Size (in)	Type of Material	Joint Type	SDR	Pressure Rating PSI	Dimensions (in)			ASTM No.
						O.D.	I.D.	Wall Thick	
Water	6	PVC	Slip	21	200	6.625	5.993	0.316	D2241
Water	1	PE	Stab	7	200	1.349	1.049	0.150	D2239

Sewer	8	PVC	Slip	35	N/A	8.400	7.920	0.240	D3034
Sewer	4	PVC	Slip	35	N/A	4.215	3.975	0.120	D3034

PIPE DIMENSIONAL DATA 5.03.05

**5.03.05 Water/Wastewater Plan and Profile Sheet(s)**

**5.03.05.01 Plan View**

Provide all items from the utility plan view sheet requirements on the Utility Plan View Sheets portion; TP 5.03.04.

**5.03.05.02 Profile View**

**5.03.05.02.01** Label all manholes and wastewater main clean-outs with manholes and clean-out numbers. Provide rim elevations with inlet and outlet invert elevations. The manhole numbers must conform to the existing manhole numbering system. Station all manholes and connections.

**5.03.05.02.02** Label all wastewater mains with size, type of material, slope, and distance. Distance shall be the actual distance of the pipeline. (O.D. of manholes to O.D. of manholes).

**5.03.05.02.03** Show all water mains that cross the sewer main and dimension Pipe O.D. to Pipe O.D. the vertical separation. Station all water mains and appurtenances.

**EXHIBIT A OF TP 5.0**

Note: (This is an example only. The actual Cost of Plant shall be developed by the Contractor and attached to the Transfer Agreement.)

**COST OF PLANT**  
 NHA Project AZ 12-51  
 Kayenta, Arizona

ITEM	QUANTITY	UNIT	LABOR	MATERIAL	TRANS.	TOTAL
8" PVC Sewer Main	1745	LF	\$7,187.22	\$5,750.00	\$1,437.44	\$14,374.66
Precast Manhole	7	EA.	\$2,101.10	\$1,681.68	\$ 420.00	\$ 4,209.78
8" Sewer Clean out	1	EA.	\$ 123.50	\$ 68.75	\$ 24.75	\$ 216.50
Sewer Service Connection	30	EA.	\$2,415.00	\$1,932.00	\$ 483.00	\$ 4,830.00
					Subtotal:	<u>\$23,630.94</u>
6" PVC Water Main	1707	LF	\$16,438.41	\$13,150.73	\$3,287.68	\$32,876.82
Fire Hydrant	3	EA.	\$ 750.00	\$ 600.00	\$ 150.00	\$ 1,500.00
6" Gate Valves	9	EA.	\$ 948.47	\$ 758.00	\$ 189.00	\$ 1,895.47
1" Water Service Line w/Meters	30	EA.	\$ 6,420.00	\$ 5,136.00	\$1,284.00	\$12,840.00
					Subtotal:	<u>\$49,112.29</u>
<b>TOTAL COST OF UTILITY PLANT:</b>						<u><b>\$72,743.23</b></u>
Less: Sewer Service Connection not transferred to Operating Utility:						<u>-\$ 4,830.00</u>
<b>TOTAL OF PLANT TRANSFERRED:</b>						<u><b>\$67,913.23</b></u>

**EXHIBIT B OF TP 5.0**  
**UTILITY TRANSFER AGREEMENT**  
**FOR**  
**WATER AND WASTEWATER FACILITIES**

This agreement is made between \_\_\_\_\_, hereinafter called the Grantor, and the **NAVAJO TRIBAL UTILITY AUTHORITY**, hereinafter, call the Grantee.

**WHEREAS**, the Grantor has constructed or caused to have constructed water and wastewater facilities located at or near \_\_\_\_\_ as shown on the plans titled \_\_\_\_\_, designed by \_\_\_\_\_, and dated \_\_\_\_\_ and said facilities and related final as-built plans already have been inspected, accepted and approved by the Grantee, and;

**WHEREAS**, the Grantor wishes to convey to the Grantee all his interest in these facilities and appurtenances constructed at the above-mentioned location on or about the above-mentioned time, along with all rights, rights of way, and privileges so that the Grantee may own, operate, and maintain all such facilities and appurtenances.

**NOW THEREFORE IT IS AGREED:**

For consideration of \$1.00, the receipt of which already has been acknowledged, the Grantor transfers, assigns, grants, and conveys to the Grantee all rights, titles, interests, easements, and rights of way in the aforementioned facilities, and;

The Grantee agrees to accept such aforementioned facilities, and further agrees to own, operate, and maintain such facilities in a reasonable and prudent manner until such facilities are determined to be no longer of any value. Further, the Grantor hereby warranties all such facilities against defects in workmanship and materials, and for design deficiencies, errors, and omissions for the period of one year beginning on \_\_\_\_\_ and ending on \_\_\_\_\_.

A listing of the total inventory and Cost of Plant determined by the Grantor, to be transferred to the Grantee, is attached as EXHIBIT \_\_\_\_\_ and made a part of this Utility Transfer Agreement. The total Cost of Plant as appears on this document is \$ \_\_\_\_\_.

**IN WITNESS THEREOF**, both parties have signed and dated this agreement.

Grantor: by \_\_\_\_\_ Date: \_\_\_\_\_  
Signature  
\_\_\_\_\_  
Printed Name

Navajo Tribal Utility Authority: by \_\_\_\_\_ Date: \_\_\_\_\_  
Signature  
\_\_\_\_\_  
Printed Name

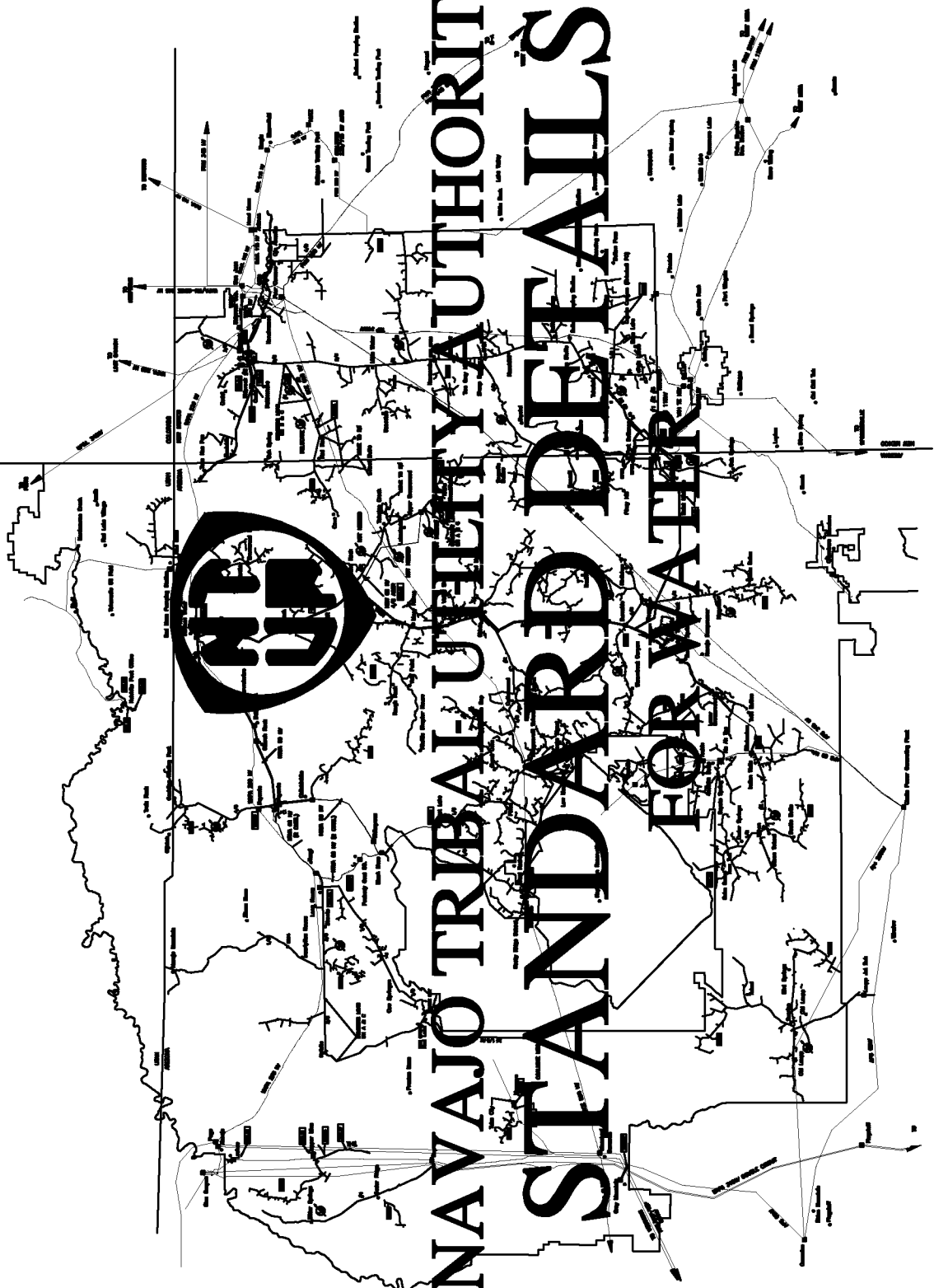

# NAVAJO TRIBE UTILITY AUTHORITY STANDARD DETAILS FOR WATER

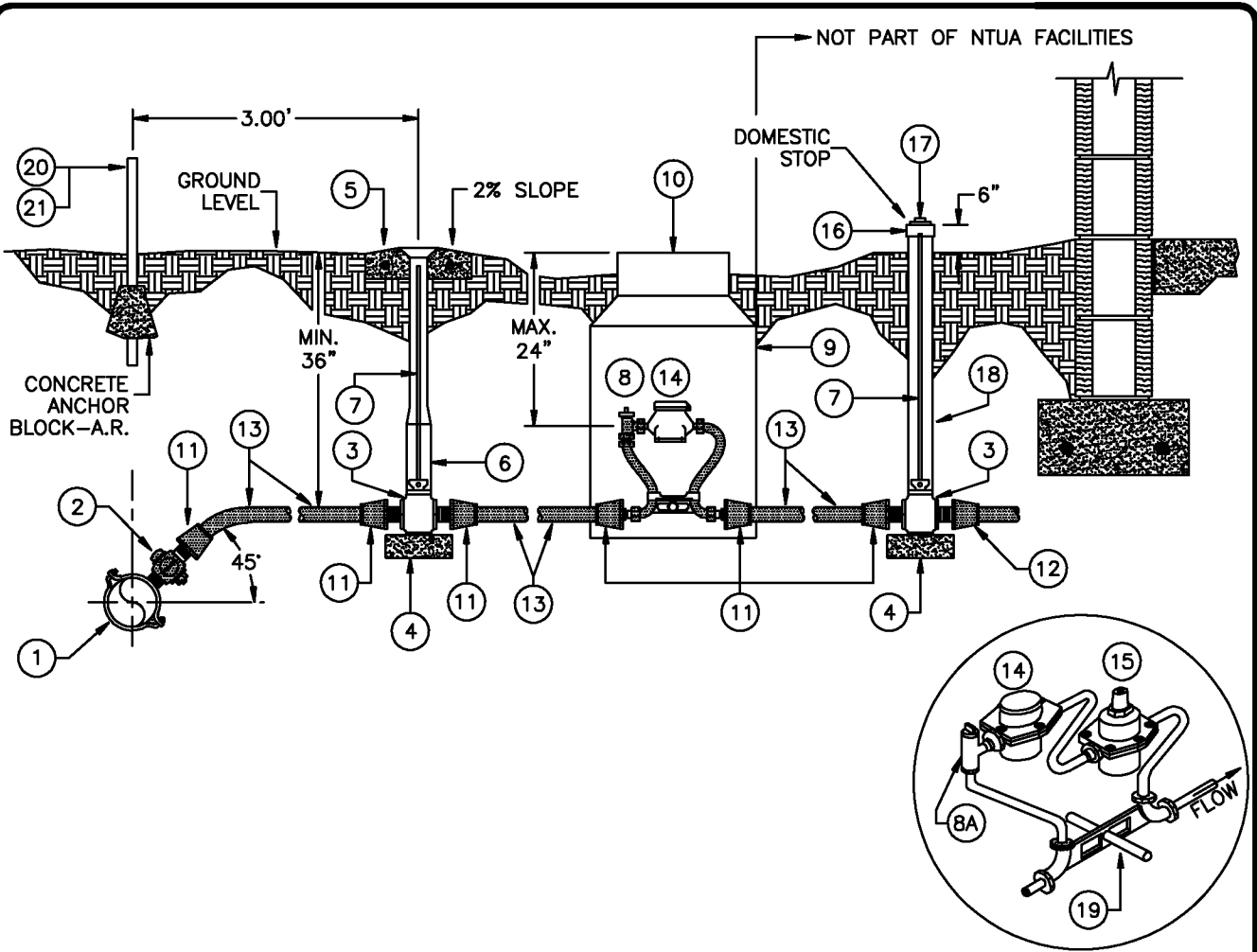

**NOTES:**

1. SELECT EITHER PAGE 2a OR 2b BASED ON METER SIZE.
2. TEST DURATION SHALL BE FOR 2 HOURS.

DATE PERFORMED: \_\_\_\_\_. LAB SAMPLE NO.: \_\_\_\_\_. INITIALED (NTUA): \_\_\_\_\_.

INDEX	SHEET
1" WATER SERVICE	1 of 5
MATERIAL LIST: 5/8" x 3/4" METER	2a of 5
MATERIAL LIST: 1" METER	2b of 5
GENERAL NOTES	3 of 5
PROPOSED CONSTRUCTION DRAWING	4 of 5
INDIVIDUAL AS-BUILT	5 of 5

AS-BUILT LOCATION OF TAP	
SYSTEM NAME	
PROJECT NO.	
SHEET NO.	
LINE NO.	
STATION NO.	

SHEET 1 OF 7

DESIGNED BY:	NTUA
SURVEYED BY:	
DRAWN BY:	NTUA
APPROVED BY:	NTUA
DATE:	04/08
PROJECT NO.	
SCALE:	NTS
ACAD FILENAME:	Water Standard
DWG. NO.	WS-1.DWG

**NAVAJO TRIBAL UTILITY AUTHORITY**  
By Order of the Navajo Tribal Council  
**1" WATER SERVICE FOR**  
**A 5/8" x 3/4"**  
**OR 1" METER**

800-899-0888      FT. DEFENCE, AZ

REVISIONS			
No.	Date	Brief	By
01	04/08	Revised	L.H.
02			
03			
04			
05			
06			





DESIGNED BY:	NTUA
SUBMITTED BY:	NTUA
DRAWN BY:	NTUA
APPROVED BY:	NTUA
DATE:	04/08
PROJECT NO.:	
SCALE:	N.T.S.
ASD FILENAME:	Water-Standard
DWG. NO.:	US-10.DWG

NAVAJO TRIBAL UTILITY AUTHORITY  
AN EQUAL OPPORTUNITY ORGANIZATION

**MATERIAL LIST: 1" SERVICE  
 WITH 5/8" x 3/4" METER**

PLANNING, AS

REVISIONS			
No.	Date	By	Initials
01	04/08		
02			
03			
04			
05			
06			



MATERIAL LIST		
ITEM	QUAN	DESCRIPTION
1	1	SADDLE, BRASS, 1" FIPT x APPROPRIATE PIPE TYPE, O.D., AND LINE PRESSURE
2	1	CORPORATION STOP, 1" MIPT x 1" FIPT, MUELLER H-10046, OAE
3	1	CURB STOP, 1" FIPT x 1" FIPT, MINNEAPOLIS PATTERN W/ O-RING, MUELLER H-10287, OAE
4	A.R.	CONCRETE BLOCK OR BRICK
5	A.R.	CONCRETE COLLAR, 18" SQUARE x 4" THICK, W/ #4 REBARS, E.W.O.C.
6	1	CURB VALVE BOX, EXTENSION TYPE, MUELLER H-10302, W/ 2" x 1 1/2" BUSHING, OAE
7	2	STATIONARY ROD 36" LONG, MUELLER PART #84338, SECURED TO THE CURB STOP W/ COTTER PIN
8	1	COPPERSETTER W/ VALVED 12" RISER FOR 5/8" x 3/4" WATER METER, FORD NO. VB72-12W-FF-44, OAE, W/ 1" IP UNION NUT/SWIVEL ASSEMBLY CONNECTION ON INLET, OUTLET, AND BRACING EYE
8a	1	TANDEM COPPERSETTER WITH VALVED 12" RISER, 5/8" x 3/4" WATER METER, FORD NO. TVB-72-12W-FF-44, OAE, W/ TWO REGULATOR ADAPTERS FOR THE PRV
9	1	METER CAN, 20" O.D. x 30" HT., DFW PLASTIC, DFW 2030 B SERIES "T" TOP
10	1	METER BOX COVER W/ FROST PLATE, FOR 20" METER CAN, 11 1/2" MINIMUM LID OPENING, CASTING M-70
11	6	INSTA-TITE FITTING, 1" MIPT x 1" STAB FOR SIDR 7 P.E. PIPE, MUELLER H15426
12	1	CONNECTOR/ADAPTER, 1" MIPT x APPROPRIATE PIPE TYPE AND O.D.
13	A.R.	PIPE, 1" P.E., ASTM D-2239, SIDR 7, 200 PSI, 200' MAX.
14	1	METER, POSITIVE DISPLACEMENT, NEPTUNE, SR, 5/8" x 3/4", GALLONS, W/ FROST PLATE
15	1	PRV, WILKENS 600 OR WATTS 25 AUB, 3/4" FIPT
16	1	ADAPTER, 3", HUB x FIPT PVC-DWV
17	1	CLEANOUT PLUG, 3" MIPT, PVC-DWV
18	1	RISER, 3" x 36" LONG, PVC-DWV
19	1	STABILIZER, 1/2" O.D. x 12" LONG PIPE, PVC, SCH. 40
20	A.R.	BLUE CARSONITE MARKER POST
21	A.R.	"WATERLINE WARNING" DECAL (FOR ITEM 20)

**NOTES:**

1. A.R. = AS REQUIRED
2. DECAL TO BE AFFIXED TO ITEM NO. 20.
3. NORMAL FLOW RATE = 1-20 GPM.
4. NTUA WILL NOT PROVIDE WATER METERS FOR SUBDIVISIONS AND DEVELOPERS.
5. WATER METER SERIAL NUMBER: \_\_\_\_\_
6. SADDLE SIZE: \_\_\_\_\_

DESIGNED BY:	NTUA
SUBMITTED BY:	NTUA
DRAWN BY:	NTUA
APPROVED BY:	NTUA
DATE:	04/08
PROJECT NO.:	
SCALE:	N.T.S.
ADDITIONAL FILE NAME:	Water - Standard
DWG. NO.:	US-1b-DWG

**NAVAJO TRIBAL UTILITY AUTHORITY**  
AN EQUAL OPPORTUNITY ORGANIZATION

**MATERIAL LIST: 1" SERVICE  
WITH 1" METER**

PLANNING, AS

REVISIONS		
No.	Date	By
01	04/08	LJA
02		
03		
04		
05		
06		



SHEET 3 OF 7

MATERIAL LIST		
ITEM	QUAN	DESCRIPTION
1	1	SADDLE, BRASS, 1" FIPT x APPROPRIATE PIPE TYPE, O.D., AND LINE PRESSURE
2	1	CORPORATION STOP, 1" MIPT x 1" FIPT, MUELLER H-10046, OAE
3	1	CURB STOP, 1" FIPT x 1" FIPT, MINNEAPOLIS PATTERN W/ O-RING, MUELLER H-10287, OAE
4	A.R.	CONCRETE BLOCK OR BRICK
5	A.R.	CONCRETE COLLAR, 18" SQUARE x 4" THICK, W/ #4 REBARS, E.W.O.C.
6	1	CURB VALVE BOX, EXTENSION TYPE, MUELLER H-10302, W/ 2" x 1 1/2" BUSHING, OAE
7	2	STATIONARY ROD, 36" LONG, MUELLER PART #84338, SECURED TO THE CURB STOP W/ COTTER PIN
8	1	COPPERSETTER W/ VALVED 12" RISER, 1" WATER METER, FORD NO. VB74-12W-FF-44, OAE, W/ 1" IP UNION NUT/SWIVEL ASSEMBLY CONNECTION ON INLET, OUTLET, AND BRACING EYE
8a	1	TANDEM COPPERSETTER WITH VALVED 12" RISER, 1" WATER METER, FORD NO. TVB-74-12W-FF-44, OAE, W/ TWO REGULATOR ADAPTERS FOR THE PRV
9	1	METER CAN, 20" O.D. x 30" HT., DFW PLASTIC, DFW 2030 B SERIES "T" TOP
10	1	METER BOX COVER W/ FROST PLATE, FOR 20" METER CAN, 11 1/2" MINIMUM LID OPENING, CASTING M-70
11	6	INSTA-TITE FITTING, 1" MIPT x 1" STAB FOR SIDR 7 P.E. PIPE, MUELLER H15426
12	1	CONNECTOR/ADAPTER, 1" MIPT x APPROPRIATE PIPE TYPE AND O.D.
13	A.R.	PIPE, 1" P.E., ASTM D-2239, SIDR 7, 200 PSI, 200' MAX.
14	1	METER, POSITIVE DISPLACEMENT, SENSUS, SR, 1", GALLONS, W/ FROST PLATE
15	1	PRV, WILKENS 600 OR WATTS 25 AUB, 1" FIPT
16	1	ADAPTER, 3", HUB x FIPT PVC-DWV
17	1	CLEANOUT PLUG, 3" MIPT, PVC-DWV
18	1	RISER, 3" x 36" LONG, PVC-DWV
19	1	STABILIZER, 1/2" O.D. x 12" LONG PIPE, PVC, SCH. 40
20	A.R.	BLUE CARSONITE MARKER POST
21	A.R.	"WATERLINE WARNING" DECAL (FOR ITEM 20)

**NOTES:**

1. A.R. = AS REQUIRED
2. DECAL TO BE AFFIXED TO ITEM NO. 20.
3. NORMAL FLOW RATE = 3-50 GPM.
4. WATER METER SERIAL NUMBER: \_\_\_\_\_
5. SADDLE SIZE: \_\_\_\_\_

1. PROVIDE 10' MINIMUM HORIZONTAL SEPARATION IN SEPARATE TRENCHES BETWEEN WATER AND SEWER SERVICES, PAST THE BUILDING PLUMBING. PROVIDE 5' MINIMUM HORIZONTAL SEPARATION BETWEEN WATER SERVICE AND OTHER UTILITIES. FOR WATER AND SEWER CROSSING. PROVIDE A MINIMUM OF 12" VERTICAL CLEARANCE, PIPE O.D. TO PIPE O.D. IF WATER SERVICE CROSSES OTHER UTILITIES, ALL STIPULATIONS FOR THE OTHER UTILITY MUST BE MET.
2. BUILDING PLUMBING, WATER AND SEWER SERVICES TO BE INSTALLED IN ACCORDANCE WITH THE NATIONAL PLUMBING CODE ADOPTED BY THE NAVAJO NATION.
3. WATER SERVICES SHALL HAVE A MINIMUM COVER OF 36" AND SHALL BE INSTALLED IN CONFORMANCE WITH NTUA STANDARDS.
4. SADDLES SHALL BE SINGLE STRAP/BAND TYPE, FOR STEEL PIPE O.D. PVC. SADDLES SHALL BE DOUBLE STRAP/BAND TYPE, FOR D.I., A.C., OR C-900 PIPE. ON EXISTING 2" PIPING, A 2" x 1" PVC TEE SHALL BE USED. CONTACT NTUA HEADQUARTERS ENGINEERING ON PIPING SMALLER THAN 2".
5. PROVIDE THE AS-BUILT SWING TIE INFORMATION FOR THE TAP POINT AND OTHER APPURTENANCES INSTALLED, ON SHEET 5 of 5.
6. THE WATER METER SHALL BE CENTERED AND SET A MAX. OF 24" BELOW THE TOP OF THE METER BOX COVER.
7. THE METER CAN SHALL BE LOCATED JUST BEYOND THE SIDEWALK AT THE PROPERTY LINE OR WITH OWNER'S PERMISSION A MINIMUM OF 10' FROM THE BUILDING.
8. WATER SERVICE LINES ARE LIMITED TO A MAXIMUM OF 200'. IF THE PRESSURE AT THE HOME SITE IS ABOVE 70 PSI, INSTALL THE APPROPRIATE TANDEM COPPERSETTER WITH AN INDIVIDUAL PRV (ITEM 8A).
9. USE FIELD MARKERS WHERE APPROPRIATE.
10. SUBMIT CONSTRUCTION COST OF NEW INSTALLATION UP TO AND INCLUDING THE METER. INDICATE AS FOLLOWS: A. MATERIAL COST, B. LABOR COST, C. EQUIPMENT COST, D. TOTAL CONSTRUCTION COST. THE COST SHALL BE SHOWN ON SHEET 5 of 5 AND THE TRANSFER AGREEMENT.
11. SHEETS 4 OF 5 AND 5 OF 5 ARE FOR RESIDENTIAL INSTALLATIONS ONLY. ALL OTHER PROJECTS, SUBMIT 4 SETS OF COMPLETE DRAWINGS.

SHEET 4 OF 7

DESIGNED BY:	NTUA
SURVEYED BY:	
DRAWN BY:	NTUA
APPROVED BY:	NTUA
DATE:	04/08
PROJECT NO.:	
SCALE:	NTS
ACAD FILENAME:	Water Standard
DWG. NO.:	WS-1c.DWG

**NAVAJO TRIBAL UTILITY AUTHORITY**  
By One Department Authority

**GENERAL NOTES FOR  
WATER SERVICE**













EQ-ENGINEERING      FT.DENANCE, AZ

REVISIONS			
No.	Date	Brief	By
01	04/08	Revised	L.H.
02			
03			
04			
05			
06			



(PLAN VIEW - NORTH ARROW REQUIRED)

\* SEE GENERAL NOTES NO. 11 ON SHEET 3 of 5

ITEM DESCRIPTION	MATERIALS			ITEM DESCRIPTION	MATERIALS		
	LEGEND	SIZE	TYPE		LEGEND	SIZE	TYPE
WATERLINE TAP 				WATERLINE, PROPOSED	-- W --		
VALVE, GATE				WATERLINE, EXISTING	—W—		
VALVE, CURB STOP				SEWERLINE, PROPOSED	-- S --		
WATER METER				SEWERLINE, EXISTING	—S—		
WATER METER W/ IND PRV				PROPOSED TIE INFORMATION			
VALVE, DOMESTIC STOP							
YARD HYDRANT				LOCATION:			
CLEAN-OUT(S)				SYSTEM:			
SEPTIC TANK				PROJECT NO:	SHT.	OF	SHTS.
INFILTRATORS				DRAWN BY:	DATE:		
DWELLING/OTHER BLDGS				PROPOSED START DATE:			

SHEET 5 OF 7

DESIGNED BY:	NTUA
SURVEYED BY:	
DRAWN BY:	NTUA
APPROVED BY:	
DATE:	04/08
PROJECT NO.	
SCALE:	NTS
ACAD FILENAME:	Water Standard
DWG. NO.	WS-1d.DWG

**NAVAJO TRIBAL UTILITY AUTHORITY**  
By One Department Agreement  
**PROPOSED INDIVIDUAL  
 INSTALLATION**









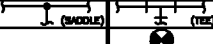

800-899-0888      FT. DEFENCE, AZ

REVISIONS			
No.	Date	Brief	By
01	04/08	Revised	L.H.
02			
03			
04			
05			
06			



(PLAN VIEW - NORTH ARROW REQUIRED)

\* SEE GENERAL NOTES NO. 11 ON SHEET 3 of 5

ITEM DESCRIPTION	MATERIALS			SWING TIES (IN FEET)				CONSTRUCTION COST:
	LEGEND	SIZE	TYPE	NW(A)	NE(B)	SW(C)	SE(D)	
WATERLINE TAP								MATERIAL:
VALVE, GATE								LABOR:
VALVE, CURB STOP								EQUIPMENT:
WATER METER								TOTAL:
WATER METER W/ IND PRV								
VALVE, DOMESTIC STOP								
YARD HYDRANT								
CLEAN-OUT(S)								
SEPTIC TANK								
INFILTRATORS								
DWELLING/OTHER BLDGS								
WATERLINE, PROPOSED	-- W --			AS-BUILT TIE INFORMATION				
WATERLINE, EXISTING	— W —			LOCATION:				
SEWERLINE, PROPOSED	-- S --			SYSTEM:				
SEWERLINE, EXISTING	— S —			PROJECT NO:				
				DRAWN BY:				DATE:
				COMPLETION DATE:				

SHEET 6 OF 7

DESIGNED BY:	NTUA
SURVEYED BY:	
DRAWN BY:	NTUA
APPROVED BY:	NTUA
DATE:	04/08
PROJECT NO.	
SCALE:	NTS
ACAD FILENAME:	Water Standard
DWG. NO.	WS-1e.DWG

**NAVAJO TRIBAL UTILITY AUTHORITY**  
By One Department Agreement  
**INDIVIDUAL**  
**AS-BUILT**

80-8990000000
PT.DISTANCE, AS

REVISIONS			
No.	Date	Brief	By
01	04/08	Revised	L.H.
02			
03			
04			
05			
06			



PLAN VIEW - (NORTH ARROW REQUIRED) - Draw location of new service/home with references to adjacent permanent structures, i.e. existing utilities, roads, washes, businesses, neighbor's home, etc.

SHEET 7 OF 7

DESIGNED BY:	NTUA
SURVEYED BY:	
DRAWN BY:	NTUA
APPROVED BY:	NTUA
DATE:	04/08
PROJECT NO.	
SCALE:	NTS
ACAD FILENAME:	Water Standard
DWG. NO.	WS-1F.DWG

**NAVAJO TRIBAL UTILITY AUTHORITY**  
By Order of the Board of Directors  
**VICINITY LOCATION  
 OF NEW SERVICE**

80-899000000000
PT.DISTANCE, AZ

REVISIONS			
No.	Date	Brief	By
01	04/08	Revised	L.H.
02			
03			
04			
05			
06			



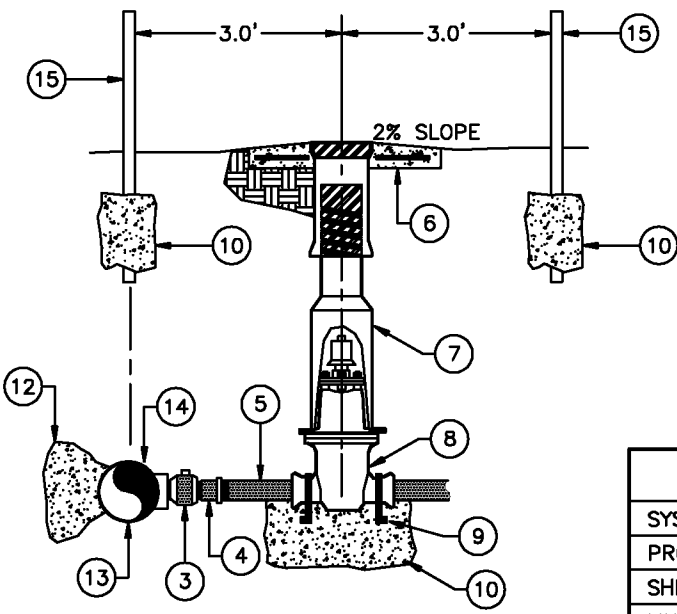
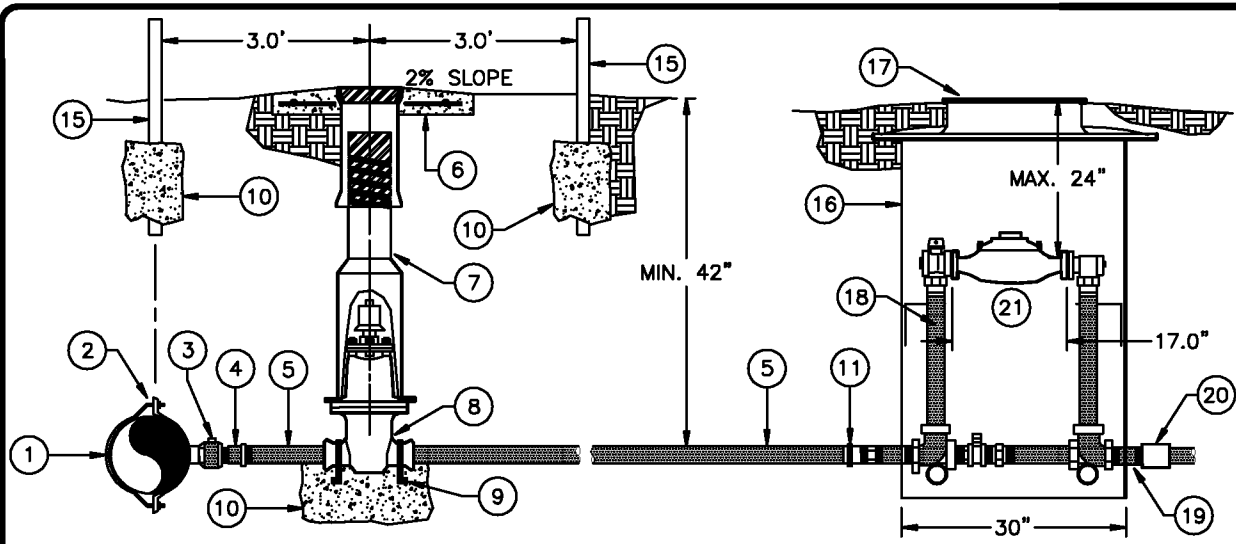

AS-BUILT LOCATION OF TAP	
SYSTEM NAME	
PROJECT NO.	
SHEET NO.	
LINE NO.	
STATION NO.	

**NOTES:**

1. TEST DURATION SHALL BE FOR 2 HOURS.

DATE PERFORMED: \_\_\_\_\_. LAB SAMPLE NO.: \_\_\_\_\_. INITIALED (NTUA): \_\_\_\_\_.

DESIGNED BY:	NTUA
SURVEYED BY:	
DRAWN BY:	NTUA
APPROVED BY:	NTUA
DATE:	04/08
PROJECT NO.	
SCALE:	NTS
ACAD FILENAME:	Water Standard
DWG. NO.	WS-2.DWG

**NAVAJO TRIBAL UTILITY AUTHORITY**  
AN EQUAL OPPORTUNITY ORGANIZATION  
**2" WATER SERVICE W/2"**  
**METER, NORMAL FLOW**  
**RATE = 8-160 GPM**  
EQ-ENGINEERING FT. DENAUCHE, AZ

REVISIONS			
No.	Date	Brief	By
01	04/08	Revised	L.H.
02			
03			
04			
05			
06			



DESIGNED BY:	NTUA
DRAWN BY:	NTUA
APPROVED BY:	NTUA
DATE:	04/08
PROJECT NO.:	
SCALE:	N.T.S.
ACAD. PLANTING:	Victor Standard
DWG. NO.:	VS-26(J)VG

NAVALO TRIBAL UTILITY AUTHORITY  
**MATERIAL LIST: 2"**  
**WATER SERVICE W/ 2"**  
**METER**  
 BR-2008080808  
 FLAGSTAFF, AZ

REVISIONS	
No.	Date
01	04/08
02	
03	
04	
05	
06	
By	Revised
L.A.	



MATERIAL LIST		
ITEM	QUAN	DESCRIPTION
1	-	PIPE, 6" OR LARGER, EXISTING
2	1	SADDLE, BRASS, PIPE SIZE & TYPE x 2" FIPT TAP, 6" AND LARGER
3	1	CORPORATION STOP, 2" MIPT x 2" FIPT, MUELLER B-20046
4	1	ADAPTER, PVC, CL 200, SDR-21, 2" GASKET x 2" MIPT
5	A.R.	PIPE, 2" PVC, SDR-21, BELL & SPIGOT
6	A.R.	CONCRETE COLLAR, 24" SQUARE x 4" THICK, W/ #4 REBARS, E.W.O.C., INSCRIBED W/ LINE SIZE AND FLOW DIRECTION
7	1	VALVE BOX, C.I., 2-PIECE, 5.25" SHAFT, SCREW TYPE, TYLER 6850 SERIES W/ LID
8	1	GATE VALVE, 2", RESILIENT SEAT WEDGE, S x S, NRS, RHT, 2" OPERATING NUT-MUELLER A2360-37
9	A.R.	REBAR, #4, CUT & SHAPE AS NEEDED
10	A.R.	CONCRETE ANCHOR BLOCK, 1.5 C.F. MIN. (DO NOT COVER JOINTS OR BOLTS)
11	1	ADAPTER, PVC, CL 200, SDR 21, 2" GASKET x 2" FIPT
12	A.R.	CONCRETE THRUST BLOCK, 1.5 C.F. MIN. (DO NOT COVER JOINTS OR BOLTS)
13	-	PIPE, 4" OR LESS, EXISTING
14	1	TEE, 4" MJ x 2" FIPT TAP W/ 2" BRASS CORP. STOP (FIG. 2-1) OR 2" TEE, PVC, CL 200
15	A.R.	BLUE CARSONITE MARKER POST W/ "WATERLINE WARNING" DECAL
16	1	METER CAN, 30" O.D. x 36" HT., DFW PLASTIC, DFW 3036 B SERIES "T" TOP
17	1	MONITOR RING & COVER, FORD MC-30-MB
18	1	COPPERSETTER, 2", FORD VBHH77-18B-11-77, OAE
19	2	NIPPLE, BRASS, 2" x 8"
20	1	ADAPTER, 2" FIPT x PIPE SIZE & TYPE
21	1	METER, 2", W-160 DRS SENSUS, W/ 2-BOLT FLANGE, GALLONS

**NOTES:**

1. A.R. = AS REQUIRED
2. DECAL TO BE AFFIXED TO ITEM NO. 15
3. ASSEMBLE AND INSTALL AS ONE UNIT
4. WATER METER SERIAL NUMBER: \_\_\_\_\_

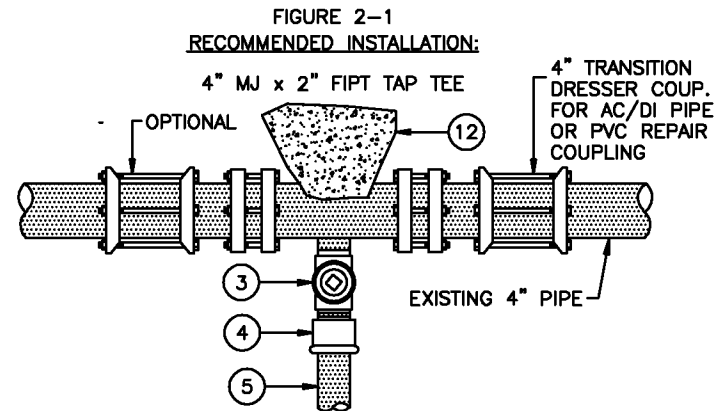



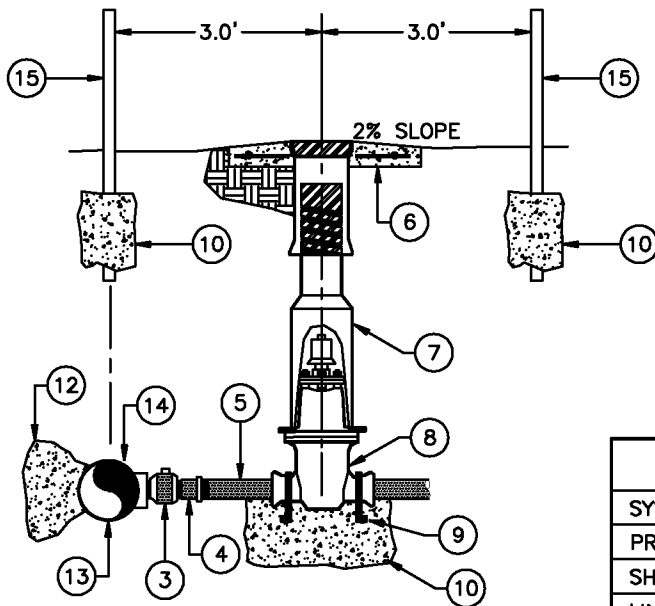
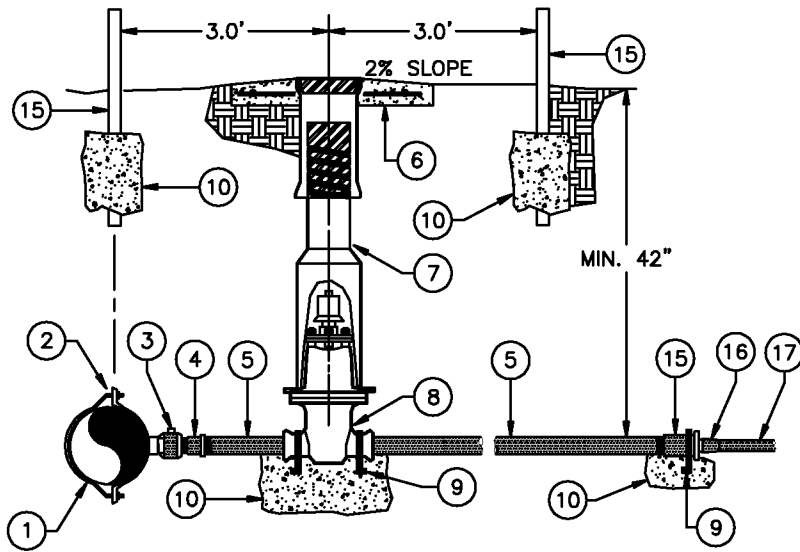

AS-BUILT LOCATION OF TAP	
SYSTEM NAME	
PROJECT NO.	
SHEET NO.	
LINE NO.	
STATION NO.	

**NOTES:**

1. TEST DURATION SHALL BE FOR 2 HOURS.

DATE PERFORMED: \_\_\_\_\_. LAB SAMPLE NO.: \_\_\_\_\_. INITIALED (NTUA): \_\_\_\_\_.

DESIGNED BY:	NTUA
SURVEYED BY:	
DRAWN BY:	NTUA
APPROVED BY:	NTUA
DATE:	04/08
PROJECT NO.	
SCALE:	NTS
ACAD FILENAME:	Water Standard
DWG. NO.	WS-3.DWG

**NAVAJO TRIBAL UTILITY AUTHORITY**  
AN EQUAL OPPORTUNITY ORGANIZATION  
**2" MAINLINE TAP FOR SERVICE IN EXCESS OF 200'**  
BY: ENGINEERING FT. DEFENCE, AZ

REVISIONS			
No.	Date	Brief	By
01	04/08	Revised	L.H.
02			
03			
04			
05			
06			



DESIGNED BY:	NTUA
DRAWN BY:	NTUA
APPROVED BY:	NTUA
DATE:	04/09
PROJECT NO.:	
SCALE:	N.T.S.
ACAD. PLANTING:	Victor Standard
EMPL. NO.:	VS-36(J)16

NAVAJO TRIBAL UTILITY AUTHORITY  
MATERIAL LIST: 2" TAP  
FOR SERVICES IN  
EXCESS OF 200'  
FLAGSTAFF, AZ

No.	Date	Revised	By
01	04/09		L.A.
02			
03			
04			
05			
06			



MATERIAL LIST		
ITEM	QUAN	DESCRIPTION
1	-	PIPE, 6" OR LARGER, EXISTING
2	1	SADDLE, BRASS, PIPE SIZE & TYPE x 2" FIPT TAP, 6" AND LARGER
3	1	CORPORATION STOP, 2" MIPT x 2" FIPT, MUELLER B-20046
4	1	ADAPTER, PVC, CL 200, SDR-21, 2" GASKET x 2" MIPT
5	A.R.	PIPE, 2" PVC, SDR-21, BELL & SPIGOT
6	A.R.	CONCRETE COLLAR, 24" SQUARE x 4" THICK, W/ #4 REBARS, E.W.O.C., INSCRIBED W/ LINE SIZE AND FLOW DIRECTION
7	1	VALVE BOX, C.I., 2-PIECE, 5.25" SHAFT, SCREW TYPE, TYLER 6850 SERIES W/ LID
8	1	GATE VALVE, 2", RESILIENT SEAT WEDGE, S x S, NRS, RHT, 2" OPERATING NUT-MUELLER A2360-37
9	A.R.	REBAR, #4, CUT & SHAPE AS NEEDED
10	A.R.	CONCRETE ANCHOR BLOCK, 1.5 C.F. MIN. (DO NOT COVER JOINTS OR BOLTS)
11	1	ADAPTER, PVC, CL 200, SDR 21, 2" GASKET x 2" FIPT
12	A.R.	CONCRETE THRUST BLOCK, 1.5 C.F. MIN. (DO NOT COVER JOINTS OR BOLTS)
13	-	PIPE, 4" OR LESS, EXISTING
14	1	TEE, 4" MJ x 2" FIPT TAP W/ 2" BRASS CORP. STOP (FIG. 2-1) OR 2" TEE, PVC, CL 200
15	A.R.	BLUE CARSONITE MARKER POST W/ "WATERLINE WARNING" DECAL
16	1	INSTA-TITE FITTING, 1" MIPT x 1" STAB FOR SIDR 7 P.E. PIPE, MUELLER H15426
17	1	PIPE, 1" P.E., ASTM D-2239, SIDR 7, 200 PSI, 200' MAX.

**NOTES:**

1. A.R. = AS REQUIRED
2. DECAL TO BE AFFIXED TO ITEM NO. 15
3. ASSEMBLE AND INSTALL AS ONE UNIT
4. WATER METER SERIAL NUMBER: \_\_\_\_\_

FIGURE 2-1  
RECOMMENDED INSTALLATION:

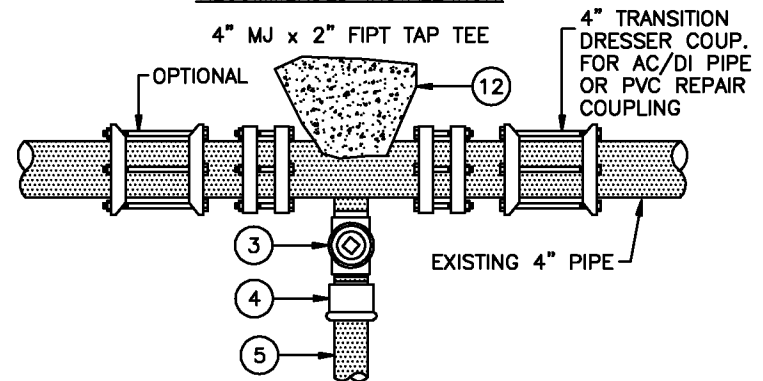

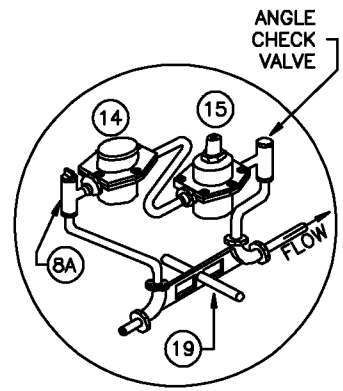
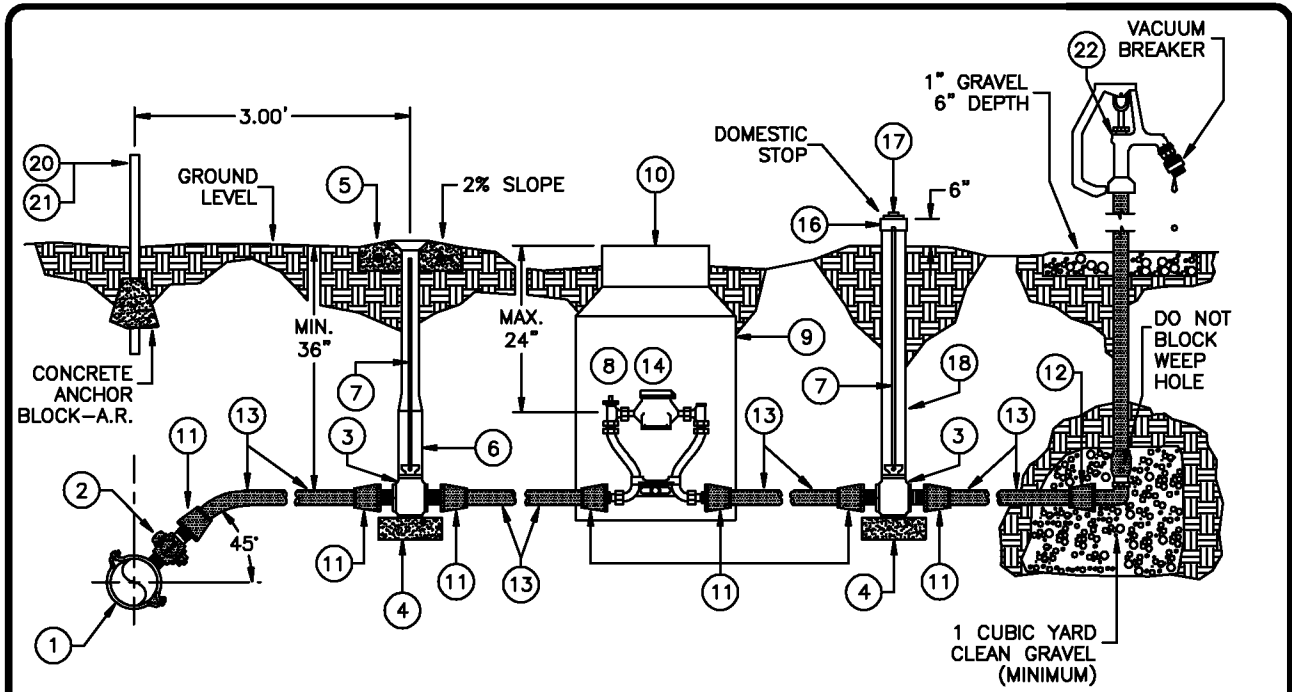

SEE NOTE 4  
ON SHEET 2 OF 2

AS-BUILT LOCATION OF TAP	
SYSTEM NAME	
PROJECT NO.	
SHEET NO.	
LINE NO.	
STATION NO.	

**NOTES:**

1. TEST DURATION SHALL BE FOR 2 HOURS.

DATE PERFORMED: \_\_\_\_\_. LAB SAMPLE NO.: \_\_\_\_\_. INITIALED (NTUA): \_\_\_\_\_.

DESIGNED BY:	NTUA
SURVEYED BY:	
DRAWN BY:	NTUA
APPROVED BY:	NTUA
DATE:	04/08
PROJECT NO.	
SCALE:	NTS
ACAD FILENAME:	Water Standard
DWG. NO.	WS-4.DWG

**NAVAJO TRIBAL UTILITY AUTHORITY**  
AN EQUAL OPPORTUNITY ORGANIZATION

**YARD HYDRANT SERVICE**

EQ-ENGINEERING      FT. DEFENCE, AZ

REVISIONS			
No.	Date	Brief	By
01	04/08	Revised	L.H.
02			
03			
04			
05			
06			



DESIGNED BY:	NTUA
DRAWN BY:	NTUA
APPROVED BY:	NTUA
DATE:	04/08
PROJECT NO.:	
SCALE:	N.T.S.
ACAD. FILENAME:	Viteri_Standard
DWG. NO.:	VS-14(J)VG

NAVALDO TRIBAL UTILITY AUTHORITY  
 MATERIAL LIST: YARD  
 HYDRANT SERVICE  
 P. 2

No.	Date	By
01	04/08	LJA
02		
03		
04		
05		
06		



MATERIAL LIST		
ITEM	QUAN	DESCRIPTION
1	1	SADDLE, BRASS, 1" FIPT x APPROPRIATE PIPE TYPE, O.D., AND LINE PRESSURE
2	1	CORPORATION STOP, 1" MIPT x 1" FIPT, MUELLER H-10046, OAE
3	2	CURB STOP, 1" FIPT x 1" FIPT, MINNEAPOLIS PATTERN W/ O-RING, MUELLER H-10287, OAE
4	A.R.	CONCRETE BLOCK OR BRICK
5	A.R.	CONCRETE COLLAR, 18" SQUARE x 4" THICK, W/ #4 REBARS, E.W.O.C.
6	1	CURB VALVE BOX, EXTENSION TYPE, MUELLER H-10302, W/ 2" x 1 1/2" BUSHING
7	2	STATIONARY ROD 36" LONG, MUELLER PART #84338, SECURED TO THE CURB STOP W/ COTTER PIN
8	1	COPPERSETTER W/ VALVED 12" RISER, 5/8" x 3/4" WATER METER, FORD NO. VHC72-12W-FF-44, OAE, W/ 1" IP UNION NUT/SWIVEL ASSEMBLY CONNECTION ON INLET, OUTLET, AND BRACING EYE
8A	1	TANDEM COPPERSETTER WITH VALVED 12" RISER, 5/8 x 3/4" WATER METER, FORD NO. TVHC72-12W-FF-44, OAE, W/ TWO REGULATOR ADAPTERS FOR THE PRV
9	1	METER CAN, 20" O.D. x 30" HT., DFW PLASTIC, DFW 2030 B SERIES "T" TOP
10	1	METER BOX COVER W/ FROST PLATE, FOR 20" METER CAN, 11 1/2" MINIMUM LID OPENING, CASTING M-70
11	7	INSTA-TITE FITTING, 1" MIPT x 1" STAB FOR SIDR 7 P.E. PIPE, MUELLER H15426
12	1	CONNECTOR/ADAPTER, 1" MIPT x APPROPRIATE PIPE TYPE AND O.D.
13	A.R.	PIPE, 1" P.E., ASTM D-2239, SIDR 7, 200 PSI, 200' MAX.
14	1	METER, POSITIVE DISPLACEMENT, NEPTUNE, SR, 5/8" x 3/4", GALLONS, W/ FROST PLATE
15	1	PRV, WILKENS 600 OR WATTS 25 AUB, 3/4" FIPT
16	1	ADAPTER, 3", HUB x FIPT PVC-DWV
17	1	CLEANOUT PLUG, 3" MIPT, PVC-DWV
18	1	RISER, 3" x 36" LONG, PVC-DWV
19	1	STABILIZER, 1/2" O.D. x 12" LONG PIPE, PVC, SCH. 40
20	A.R.	BLUE CARSONITE MARKER POST
21	A.R.	"WATERLINE WARNING" DECAL (FOR ITEM 20)
22	1	HYDRANT, FROST FREE, 3/4" x 3' BURY, MERRIL MFG., ORDER NO. E7503, OAE

- NOTES:
1. A.R. = AS REQUIRED
  2. DECAL TO BE AFFIXED TO ITEM NO. 20.
  3. NORMAL FLOW RATE = 1-20 GPM.
  4. NTUA WILL NOT PROVIDE WATER METERS FOR SUBDIVISIONS AND DEVELOPERS.
  5. WATER METER SERIAL NUMBER: \_\_\_\_\_
  6. SADDLE SIZE: \_\_\_\_\_

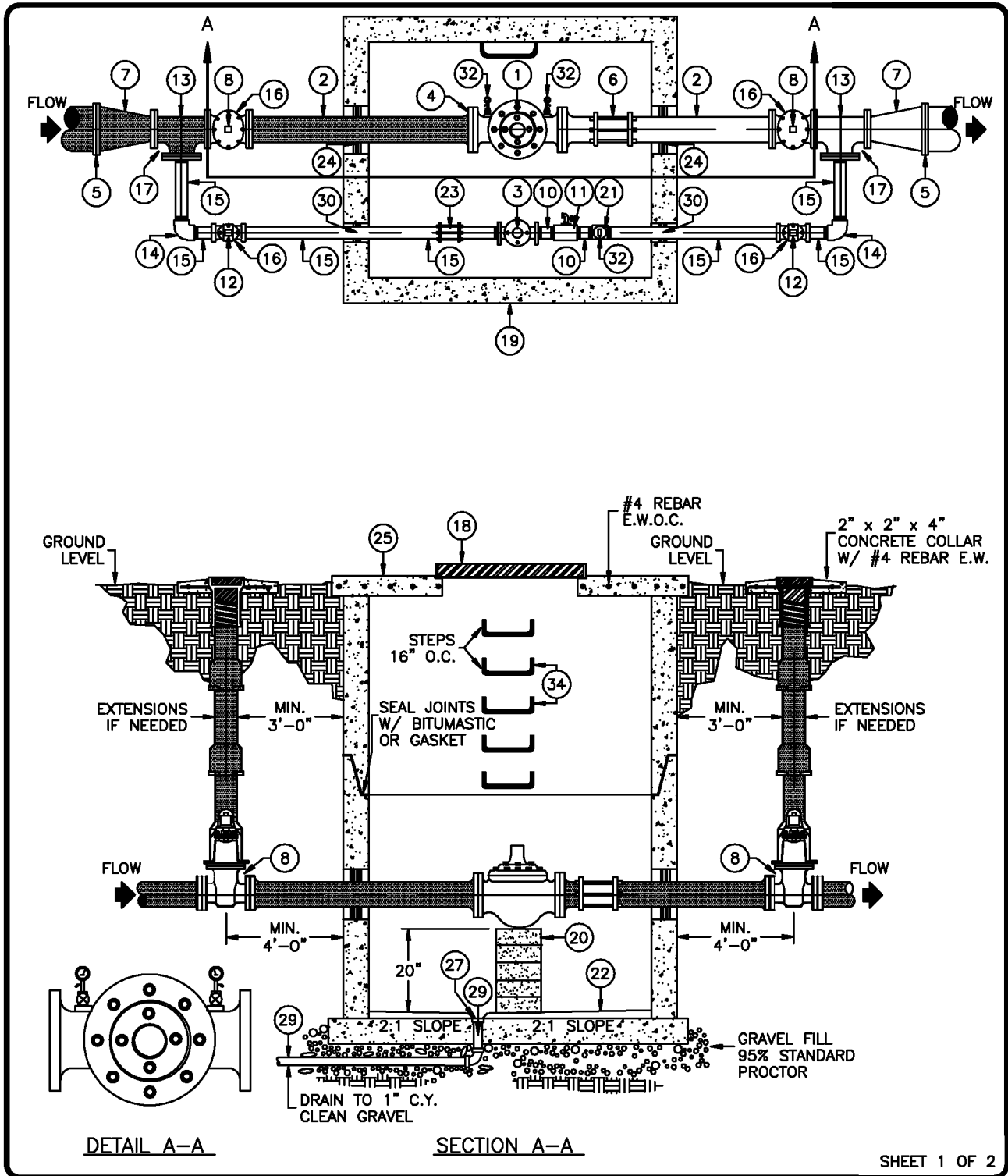

DESIGNED BY:	NTUA
SURVEYED BY:	
DRAWN BY:	NTUA
APPROVED BY:	NTUA
DATE:	04/08
PROJECT NO.	
SCALE:	NTS
ACAD FILENAME:	Water Standard
DWG. NO.	WS-5.DWG

**NAVAJO TRIBAL UTILITY AUTHORITY**  
AN EQUAL OPPORTUNITY ORGANIZATION

**6" x 2" PRV**

BQ-ENGINEERING      FT. DEVAUCE, AZ

REVISIONS			
No.	Date	Brief	By
01	04/08	Revised	L.H.
02			
03			
04			
05			
06			



**MATERIAL LIST**

ITEM	QUAN	DESCRIPTION
1	1	6" CLA VAL, MODEL 92-01 W/ OPTIONS B, C, & D, FLANGED
2	A.R.	6" PIPE, D.I., PLAIN END, CUT TO FIT
3	1	2" PRV, CLA-VAL MODEL 92-01 W/ OPTIONS B, C, & D, FIPT
4	4	6" "E-Z" FLANGED ADAPTER, D.I.O.D. PIPE, EBAA IRON SERIES 1000, OAE
5	2	MAINLINE "E-Z" FLANGED ADAPTER, PVC-O.D., EBAA IRON SERIES 8500, OAE
6	1	6" DRESSER COUPLING, 6" LONG FOR D.I.O.D. PIPE
7	2	MAIN LINE SIZE O.D. x 6" REDUCER, FLANGED, D.I., CLASS 350 SSB
8	2	6" FLANGED GATE VALVE, N.R.S., R.H.T., R.W. 2" OPERATING NUT
9	2	6" TEE, FLANGED, D.I., CLASS 350 SSB
10	2	
11	1	2" TEE, G.I., W/ 2" x 3/4" BUSHING W/ HOSE BIB
12	2	2" GATE VALVE, FIPT, R.H.T., N.R.S., C.I., W/ 2" OPERATING NUT
14	2	2" 90° ELBOW, FIPT, COATED AND TAPED FOR CORROSION PROTECTION
15	A.R.	2" G.I. PIPE, CUT & THREADED AS NEEDED, COATED AND TAPED FOR CORROSION PROTECTION
16	4	VALVE BOX, 2-PIECE SCREW TYPE, 5 1/4" SHAFT W/DROP LID, TYLER 6850 SERIES
17	2	6" x 2" D.I. BLIND FLANGE
18	1	REINFORCED CONCRETE TOP, PRE-CAST W/ LOCKING ALUMINUM ACCESS FRAME AND COVER, HALLIDAY MODEL NO. H1W3636
19	1	8' x 6' VAULT, 5" WALLS, PRECAST W/ 6" REINFORCED CONCRETE BASE (SEE NOTE 4)
20	A.R.	SOLID BLOCK, 4" x 8" x 16", OAE
21	1	2" TEE, G.I., W/ 2" x 3/4" BUSHING W/ 3/4' x 1/4" BUSHING FOR PRESSURE GAUGE
22	A.R.	CEMENT, NO-SHRINK GROUT
23	1	2" DRESSER COUPLING 6" LONG
24	2	BORE DONUTS, 10" W/ 6" HOLE
25	2	BORE DONUTS, 6" W/ 2" HOLE
27	1	FLOOR DRAIN TO CONNECT TO 2" PVC
28	1	2" 90° ELBOW, PVC, SCH. 40
29	A.R.	PIPE, 2" PVC, SCH. 40
30		
32	3	PRESSURE GAUGE W/ 1/4" BRASS SHUTOFF VALVE
33	A.R.	PLASTIC COATED STEEL OR ALUMINUM STEP

**NOTES:**

1. PROVIDE ADEQUATE CLEARANCE BETWEEN FLANGE BOLTS AND WALL FOR MAINTENANCE.
2. HEX HEAD BOLTS/NUTS TO BE STAINLESS STEEL, TYPE 18-8.
3. NORMAL FLOW RATE: 1800 GPM,
4. OTHER VAULT CONFIGURATION MAY BE SUBMITTED FOR CONSIDERATION.

DESIGNED BY:	NTUA
SURVEYED BY:	
DRAWN BY:	NTUA
APPROVED BY:	NTUA
DATE:	04/08
PROJECT NO.	
SCALE:	NTS
ACAD FILENAME:	Water Standard
DWG. NO.	WS-50.DWG

**NAVAJO TRIBAL UTILITY AUTHORITY**  
AN EQUAL OPPORTUNITY ORGANIZATION  
**MATERIAL LIST:**  
**6" x 2" PRV**

EE-ENGINEERING
PT-DESIGN/CL, AS

REVISIONS			
No.	Date	Brief	By
01	04/08	Revised	L.H.
02			
03			
04			
05			
06			



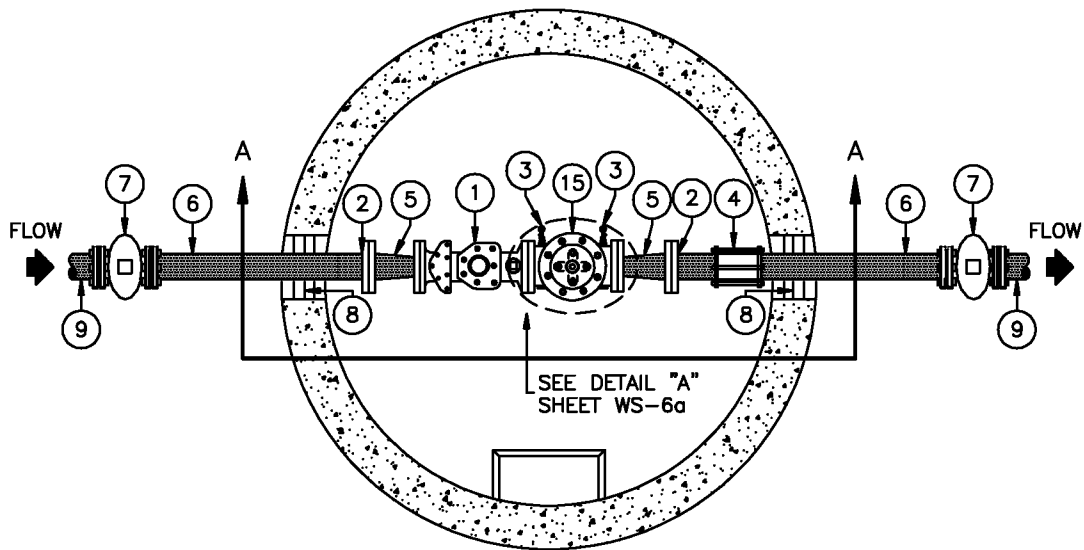

PLAN VIEW

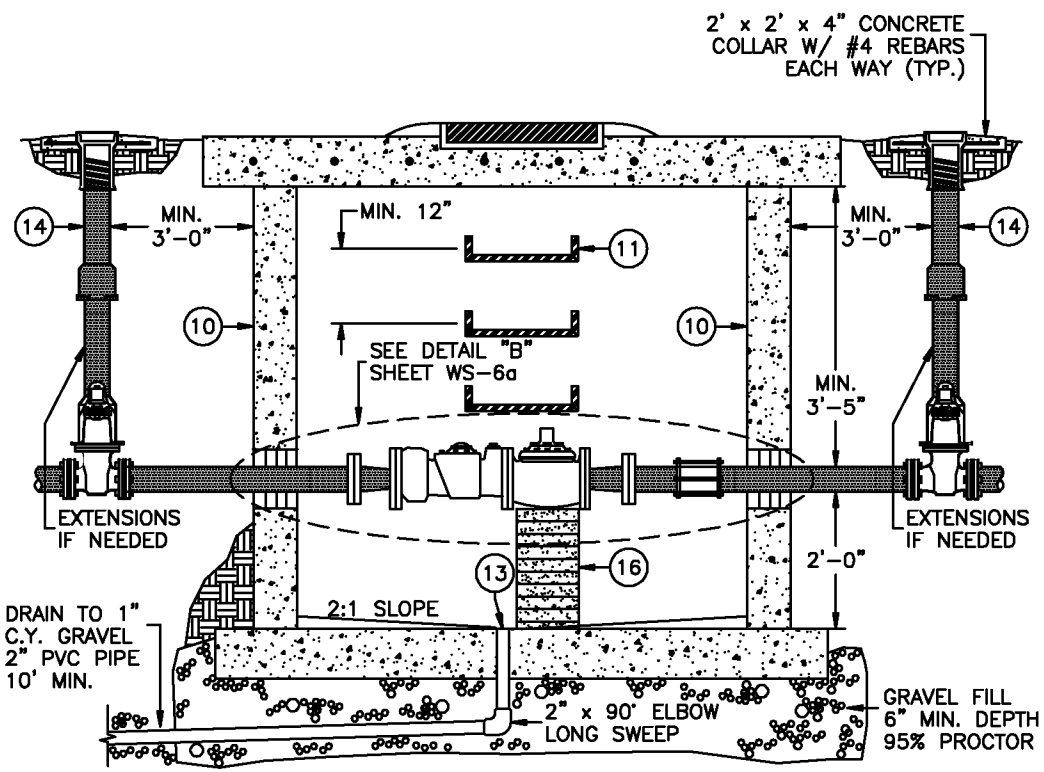

SECTION A-A

DESIGNED BY:	NTUA
SURVEYED BY:	
DRAWN BY:	NTUA
APPROVED BY:	NTUA
DATE:	04/08
PROJECT NO.	
SCALE:	NTS
ACAD FILENAME:	Water Standard
DWG. NO.	WS-6.DWG

**NAVAJO TRIBAL UTILITY AUTHORITY**  
AN EQUAL OPPORTUNITY ORGANIZATION

**3" W-350 DRS TURBO  
 METER: FLOW RATE  
 5-350 GPM**

EQ-ENGINEERING FT. DEFENCE, AZ

REVISIONS			
No.	Date	Brief	By
01	04/08	Revised	L.H.
02			
03			
04			
05			
06			



**MATERIAL LIST**

ITEM	QUAN	DESCRIPTION
1	1	3" SENSUS, W-350 DRS TURBO METER, GALS., FLANGED
2	2	4" "E-Z" FLANGE, ADAPTER DI. PIPE O.D., EBAA IRON SERIES 1004
3	2	PRESSURE GAUGE W/ 1/4" SHUT-OFF VALVE
4	2	4" COUPLING, DRESSER, MIN. 6" LENGTH
5	2	4" x 3" REDUCER, FLANGED x FLANGED, CLASS 350 SSB
6	A.R.	4" PIPE, D.I. (FIELD CUT, AS NEEDED)
7	2	4" GATE VALVE, RESILIENT SEAT, R.H.T., MJ x MJ, 2' OPERATING NUT
8	2	8" x 4" BORE DONUT
9	A.R.	PIPE, EXISTING
10	1	6" I.D. VAULT, PRECAST, W/ 8" SLAB TOP
11	A.R.	2" TEE, GALVANIZED, W/ 2" x 3/4" BUSHING W/ HOSE BIB
12	2	STEPS, PLASTIC COATED STEEL OR ALUMINUM
13	A.R.	FLOOR DRAIN ASSEMBLY, 2" PVC
14	2	VALVE BOX, 5-1/4", W/ CAST IRON LID (TYLER 6850)
15	1	3" PRESSURE REDUCING VALVE, CLA-VAL 92-01, FLANGED W/ OPTIONS B, C, D. OR 3" BRASS CHECK VALVE IF LINE PRESSURE IS 80 PSI OR LESS.
16	A.R.	SOLID BLOCK, 4" x 8" x 16", OAE

**NOTES:**

1. A.R. = AS REQUIRED
2. NORMAL FLOW RATE: 5-350 GPM.
3. INTERMITTENT MAX. FLOW RATE: 450 GPM.
4. PROVIDE ADEQUATE CLEARANCE BETWEEN FLANGED BOLTS AND WALL.
5. GATE VALVE & MANHOLE TO BE SUPPORTED ON 95% STANDARD PROCTOR

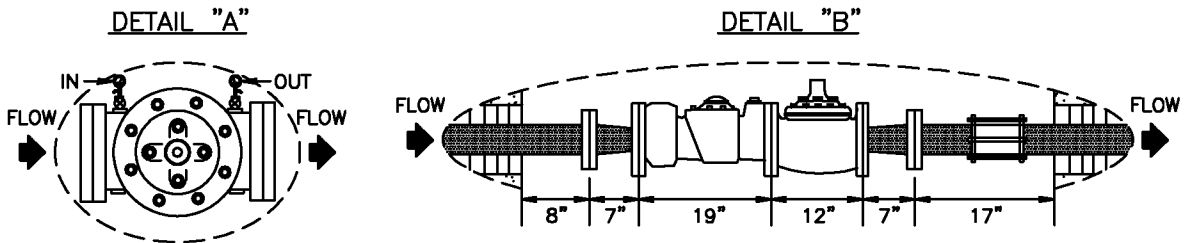

SHEET 2 OF 2

DESIGNED BY:	NTUA
SURVEYED BY:	
DRAWN BY:	NTUA
APPROVED BY:	NTUA
DATE:	04/08
PROJECT NO.	
SCALE:	NTS
ACAD FILENAME:	Water Standard
DWG. NO.	WS-6a.DWG

**NAVAJO TRIBAL UTILITY AUTHORITY**  
AN EQUAL OPPORTUNITY ORGANIZATION  
**MATERIAL LIST: 3" W-350  
 DRS TURBO METER**  
EE-ENGINEERING FT. DEVAUCE, AZ

REVISIONS			
No.	Date	Brief	By
01	04/08	Revised	L.H.
02			
03			
04			
05			
06			





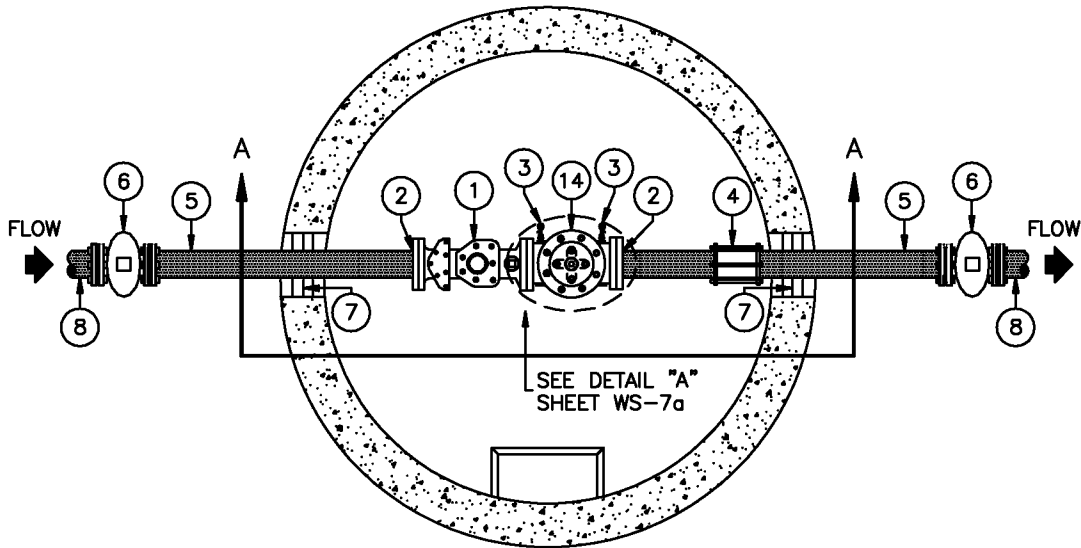

PLAN VIEW

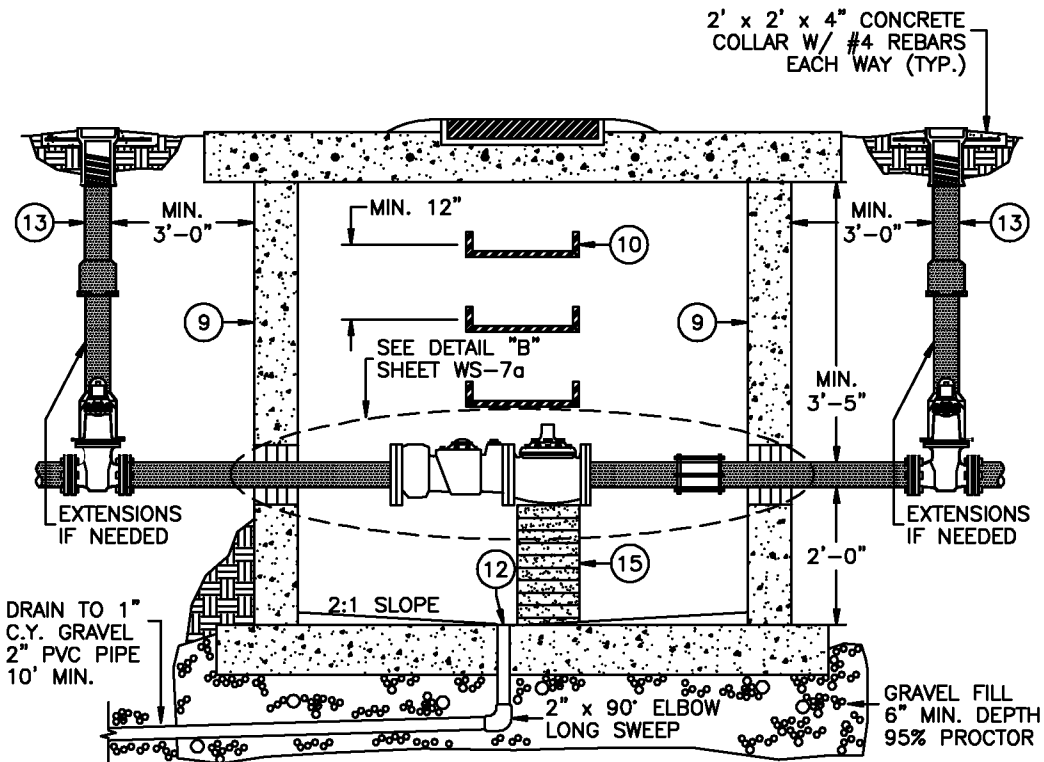

SECTION A-A

DESIGNED BY:	NTUA
SURVEYED BY:	
DRAWN BY:	NTUA
APPROVED BY:	NTUA
DATE:	04/08
PROJECT NO.	
SCALE:	NTS
ACAD FILENAME:	Water Standard
DWG. NO.	WS-7.DWG

**NAVAJO TRIBAL UTILITY AUTHORITY**  
AN EQUAL OPPORTUNITY ORGANIZATION

**4" W-1000 DRS TURBO  
 METER: FLOW RATE  
 15-1000 GPM**

EQ-ENGINEERING FT. DENAVANCE, AZ

REVISIONS			
No.	Date	Brief	By
01	04/08	Revised	L.H.
02			
03			
04			
05			
06			



### MATERIAL LIST

ITEM	QUAN	DESCRIPTION
1	1	4" SENSUS, W-1000 DRS TURBO METER, GAL.S., FLANGED
2	2	4" "E-Z" FLANGE, ADAPTER DI. PIPE O.D., EBAA IRON SERIES 1004
3	2	PRESSURE GAUGE W/ 1/4" SHUT-OFF VALVE
4	2	4" COUPLING, DRESSER, MIN. 6" LENGTH
5	A.R.	4" PIPE, D.I. (FIELD CUT, AS NEEDED)
6	2	4" GATE VALVE, RESILIENT SEAT, R.H.T., MJ x MJ, 2' OPERATING NUT
7	2	8" x 4" BORE DONUT
8	A.R.	PIPE, EXISTING, 4" OR LARGER
9	1	6" I.D. VAULT, PRECAST, W/ 8" SLAB TOP
10	A.R.	STEPS, PLASTIC COATED STEEL OR ALUMINUM
11	1	LOCKING ALUMINUM ACCESS FRAME AND COVER
12	A.R.	FLOOR DRAIN ASSEMBLY, 2" PVC
13	2	VALVE BOX, 5-1/4", W/ CAST IRON LID (TYLER 6850)
14	1	4" PRESSURE REDUCING VALVE, CLA-VAL 92-01, FLANGED W/ OPTIONS B, C, D. OR 4" BRASS CHECK VALVE IF LINE PRESSURE IS 80 PSI OR LESS.
15	A.R.	SOLID BLOCK, 4" x 8" x 16", OAE

**NOTES:**

1. A.R. = AS REQUIRED
2. NORMAL FLOW RATE: 15-1000 GPM.
3. INTERMITTENT MAX. FLOW RATE: 1250 GPM.
4. PROVIDE ADEQUATE CLEARANCE BETWEEN FLANGED BOLTS AND WALL.
5. GATE VALVE & MANHOLE TO BE SUPPORTED ON 95% STANDARD PROCTOR.
6. CENTER THE METER ASSEMBLY INSIDE VAULT, AS SHOWN IN SECTION A-A.

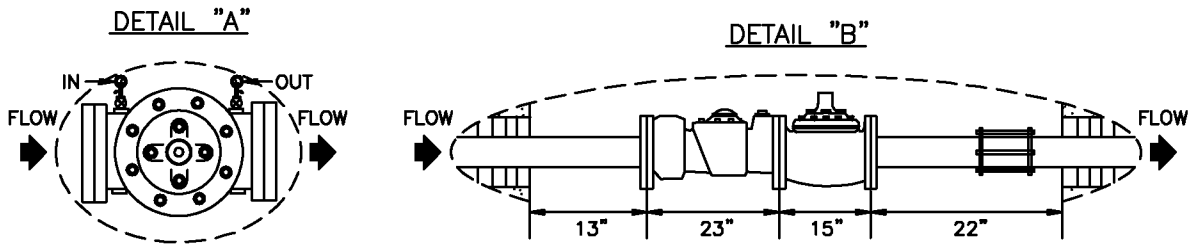

SHEET 2 OF 2

DESIGNED BY:	NTUA
SURVEYED BY:	
DRAWN BY:	NTUA
APPROVED BY:	NTUA
DATE:	04/09
PROJECT NO.	
SCALE:	NTS
ACAD FILENAME:	Water Standard
DWG. NO.	WS-7a.DWG

**NAVAJO TRIBAL UTILITY AUTHORITY**  
AN EQUAL OPPORTUNITY ORGANIZATION

**MATERIAL LIST: 4" W-1000  
DRS TURBO METER**

BY: ENGINEERING PT. DEVAUCE, AS

REVISIONS			
No.	Date	Brief	By
01	04/09	Revised	L.H.
02			
03			
04			
05			
06			



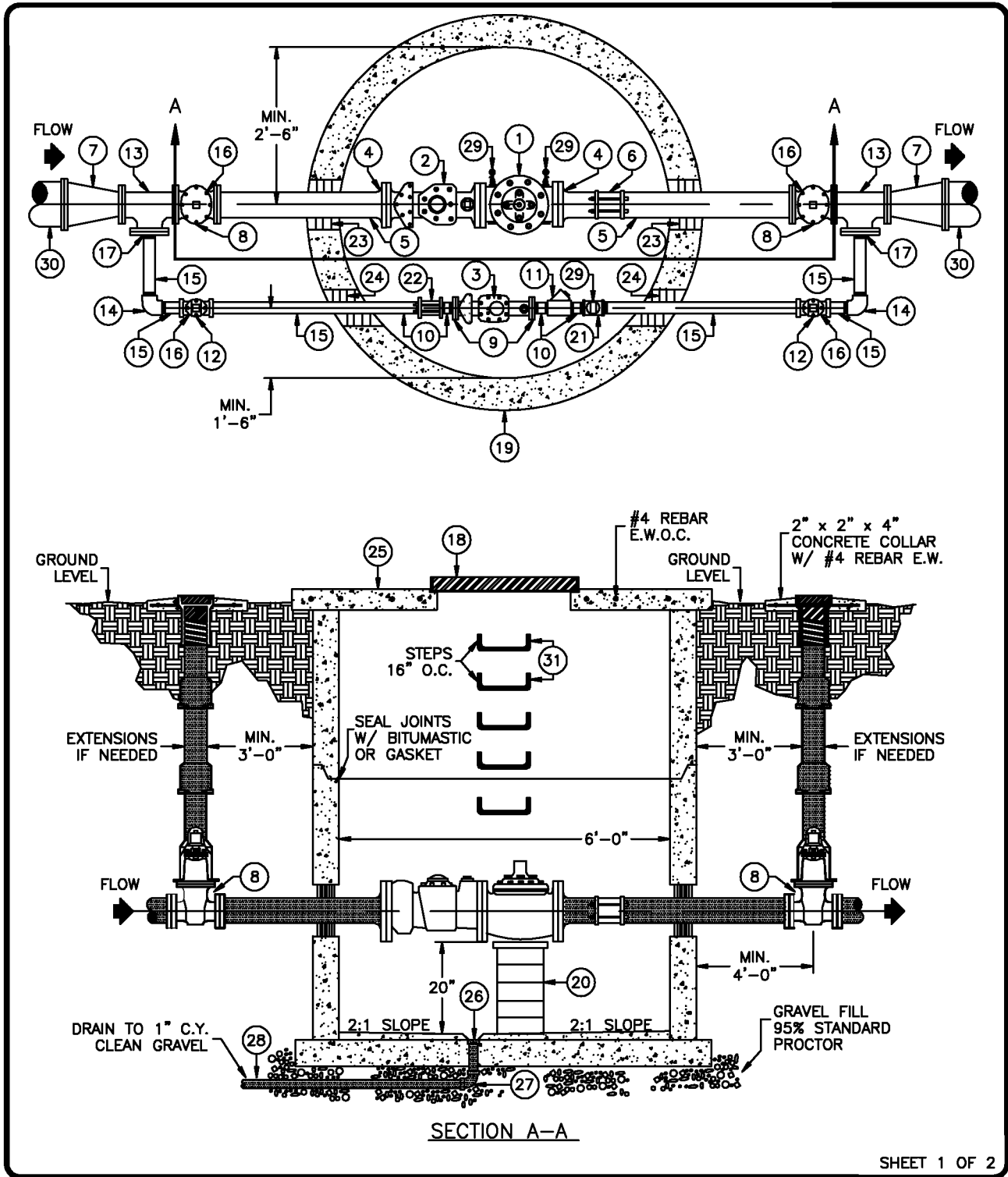

DESIGNED BY:	NTUA
SURVEYED BY:	
DRAWN BY:	NTUA
APPROVED BY:	NTUA
DATE:	04/08
PROJECT NO.:	
SCALE:	NTS
ACAD FILENAME:	Water Standard
DWG. NO.:	WS-8.DWG

**NAVAJO TRIBAL UTILITY AUTHORITY**  
AN EQUAL OPPORTUNITY ORGANIZATION

**4" x 2" METER ON 6" WATER LINE IN NON-TRAFFIC AREA**

EE-ENGINEERING      FT.DENVER, CO

REVISIONS			
No.	Date	Brief	By
01	04/08	Revised	L.H.
02			
03			
04			
05			
06			



### MATERIAL LIST

ITEM	QUAN	DESCRIPTION
1	1	4" CLA VAL, MODEL 92-01 W/ OPTIONS A, B, C, D, S, & Y FLANGED
2	1	4" SENSUS W-1000 DRS TURBOMETER, FLANGED , GALLONS
3	1	2" SENSUS W-160 DRS TURBOMETER, FLANGED, GALLONS
4	2	4" "E-Z" FLANGED ADAPTER, D.I.O.D. PIPE, EBAA IRON SERIES 1000, OAE
5	2	4" PIPE, D.I., FLANGED PLAIN END (MIN. 6')
6	1	4" DRESSER COUPLING, 6" LONG FOR D.I.O.D. PIPE
7	2	6" x 4" REDUCER, FLANGED, D.I. FLANGED
8	2	4" FLANGED GATE VALVE, N.R.S., R.H.T., R.S.W. 2" OPERATING UNIT
9	2	2" THREADED COMPANION FLANGES, BRASS W/ BOLT KIT
10	3	2" x 6" NIPPLES, BRASS
11	1	2" BRASS CHECK VALVE, FIPT OR 2" 90-01 W/ CHECK IF UPSTREAM PRESSURE IS OVER 70 PSI
12	2	2" AWWA, GATE VALVE, R.H.T., N.R.S., FIPT C.I., W/ 2" WRENCH NUT
13	2	4" x 4" TEE, FLANGED, D.I.
14	2	2" G.I. ELBOW 90°, FIPT, TAPED OR COATED FOR CORROSION PROTECTION
15	20 ±	2" G.I. PIPE, CUT & THREADED, AS NEEDED, TAPED OR COATED FOR CORROSION
16	4	VALVE BOX, C.I., 2-PIECE, 5 1/4" SHAFT, SCREW TYPE W. LID, TYLER 6850
17	2	REDUCING FLANGE, 4" FLANGE x 2' FIPT D.I.
18	1	LOCKING ALUMINUM ACCESS FRAME AND COVER (3" x 3" MIN.)
19	1	6' I.D. VAULT, PRECAST W/ 8" REINFORCING CONCRETE BASE
20	A.R.	SOLID BLOCK, 4" x 8' x 16", OAE
21	2	2" G.I. TEE W/ 2" x 3/4" BUSHING ADAPTER W/ 3/4" x 1/4" BRASS BUSHING, FOR PRESSURE GAUGE
22	1	2" DRESSER COUPLING 6" LONG
23	2	BORE DONUTS 4" x 8"
24	2	BORE DONUTS 2" x 6"
25	1	REINFORCED CONCRETE TOP, PRE-CAST
26	1	FLOOR DRAIN, 2" PVC
27	1	ELBOW, 90°, 2" PVC LONG SWEEP
28	A.R.	PIPE, 2" PVC, 10" MIN.
29	2	PRESSURE GAUGE W/ 1/4" BRASS SHUTOFF VALVE AND BRASS BUSHING TO FIT
30	2	6" "E-Z" FLANGED ADAPTER, PVC-O.D., EBAA IRON SERIES 8500, OAE
31	A.R.	PLASTIC COATED STEEL OR ALUMINUM STEP

**NOTES:**

1. PROVIDE ADEQUATE CLEARANCE BETWEEN FLANGE BOLTS AND WALL FOR MAINTENANCE.
2. GATE VALVES AND TEES TO BE SUPPORTED ON 95% STANDARD PROCTOR.
3. OTHER VAULT CONFIGURATION MAY BE SUBMITTED FOR CONSIDERATION.
4. PAINT EXPOSED GALVANIZED PIPING & FITTINGS IN VAULT.
5. HEX HEAD BOLTS/NUTS TO BE STAINLESS STEEL, TYPE 18-8.
6. MORNAL FLOW RATE: 4-1000 GPM.

SHEET 2 OF 2

DESIGNED BY:	NTUA
SURVEYED BY:	
DRAWN BY:	NTUA
APPROVED BY:	NTUA
DATE:	04/08
PROJECT NO.	
SCALE:	NTS
ACAD FILENAME:	Water Standard
DWG. NO.	WS-8a.DWG

**NAVAJO TRIBAL UTILITY AUTHORITY**  
By Order of the Navajo Tribal Council  
**MATERIAL LIST: 4" x 2"**  
**METER ON 6"**  
**WATER LINE**

HQ-ENGINEERING PT.DEPANANCE, AZ

REVISIONS			
No.	Date	Brief	By
01	04/08	Revised	L.H.
02			
03			
04			
05			
06			



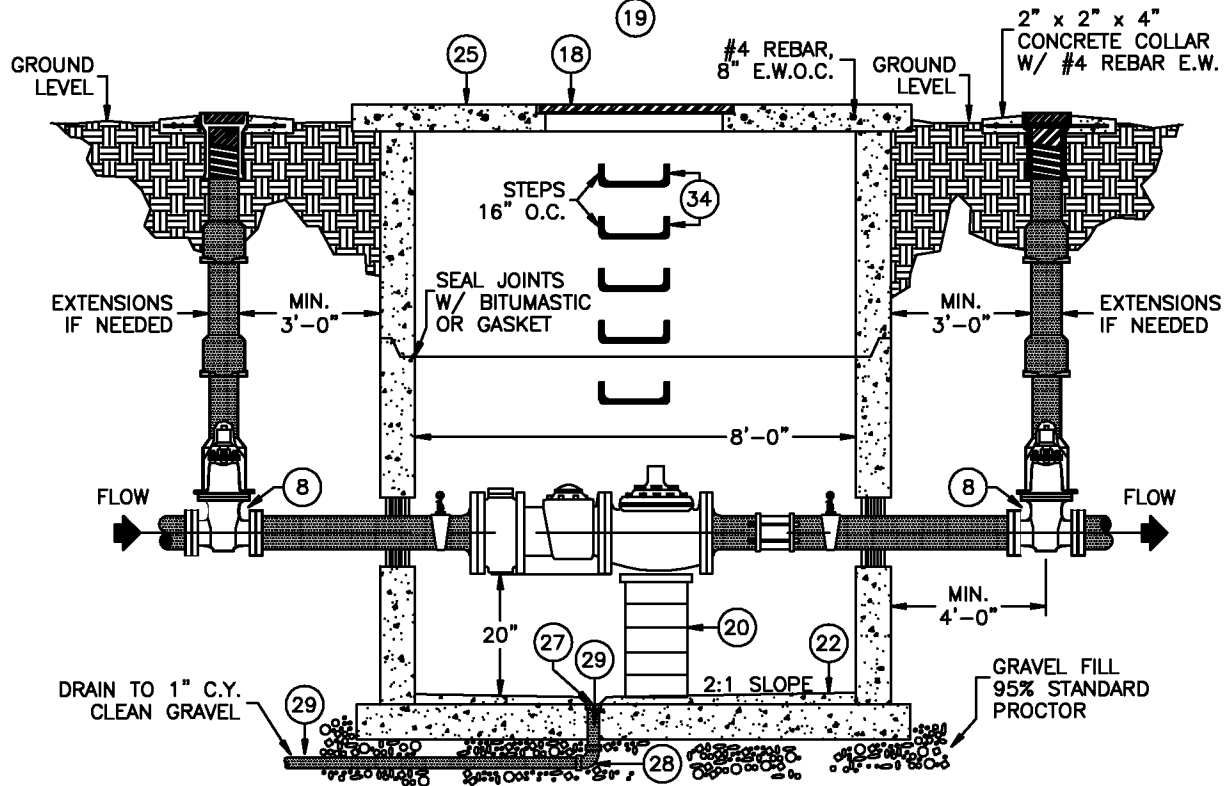
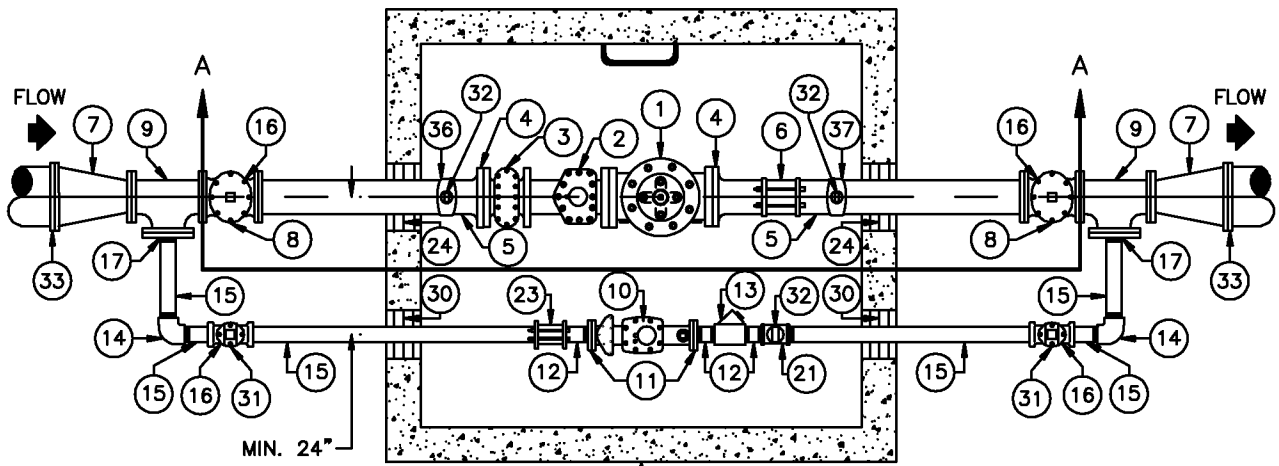

SECTION A-A

NOTES:

1. PROVIDE ADEQUATE CLEARANCE BETWEEN FLANGE BOLTS AND WALL FOR MAINTENANCE.
2. GATE VALVES AND TEES TO BE SUPPORTED ON 95% STANDARD PROCTOR.
3. OTHER VAULT CONFIGURATION MAY BE SUBMITTED FOR CONSIDERATION.
4. PAINT EXPOSED GALVANIZED PIPING & FITTINGS IN VAULT.
5. HEX HEAD BOLTS/NUTS TO BE STAINLESS STEEL, TYPE 18-8.
6. NORMAL FLOW RATE: 4-2000 GPM.

DESIGNED BY:	NTUA
SURVEYED BY:	
DRAWN BY:	NTUA
APPROVED BY:	NTUA
DATE:	04/08
PROJECT NO.	
SCALE:	NTS
ACAD FILENAME:	Water Standard
DWG. NO.	WS-9.DWG

NAVAJO TRIBAL UTILITY AUTHORITY  
BY THE TRIBAL GOVERNMENT

**6" x 2" METER ON 8"  
WATER LINE IN  
NON-TRAFFIC AREA**

BSQ-ENGINEERING FT. DEFENCE, AZ

REVISIONS			
No.	Date	Brief	By
01	04/08	Revised	L.H.
02			
03			
04			
05			
06			



**MATERIAL LIST**

ITEM	QUAN	DESCRIPTION
1	1	6" CLA VAL, MODEL 90-01 W/ OPTIONS A, B, C, D, S, & Y FLANGED
2	1	6" SENSUS W-2000 DRS TURBOMETER, FLANGED, GALLONS
3	1	6" STRAINER, AWWA TYPE, BRONZE BODY, STAINLESS STEEL SCREEN
4	2	6" "E-Z" FLANGED ADAPTER, D.I.O.D. PIPE, EBAA IRON SERIES 1000, OAE
5	2	6" PIPE, D.I., FLANGED PLAIN END (MIN. 6')
6	1	6" DRESSER COUPLING, 6" LONG FOR D.I.O.D. PIPE
7	2	8" x 6" REDUCER, FLANGED, D.I. FLANGED
8	2	6" FLANGED GATE VALVE, N.R.S., R.H.T., R.S.W. 2" OPERATING UNIT
9	2	6" x 6" x 6" TEE, D.I., FLANGED
10	1	2" SENSUS W-160 DRS TURBOMETER, FLANGED, GALLONS
11	2	2" THREADED COMPANION FLANGES, BRASS W/ BOLT KIT
12	2	2" x 6" NIPPLES, BRASS, THREADED
13	1	2" BRASS CHECK VALVE, FIPT OR 2" 90-01 W/ CHECK IF UPSTREAM PRESSURE IS OVER 70 PSI
14	2	2" G.I. ELBOW 90°, FIPT, TAPED OR COATED FOR CORROSION PROTECTION
15	20 ±	2" G.I. PIPE, CUT & THREADED, AS NEEDED, TAPED OR COATED FOR CORROSION
16	4	VALVE BOX, C.I., 2-PIECE, 5 1/4" SHAFT, SCREW TYPE W. LID, TYLER 6850
17	2	REDUCING FLANGE, 4" FLANGE x 2' FIPT D.I.
18	1	LOCKING ALUMINUM ACCESS FRAME AND COVER (3" x 3" MIN.)
19	1	6' x 8' x 6' I.D. VAULT, PRECAST W/ 8" REINFORCING CONCRETE BASE
20	A.R.	SOLID BLOCK, 4" x 8' x 16", OAE
21	2	2" G.I. TEE W/ 2" x 3/4" BUSHING ADAPTER W/ 3/4" x 1/4" BRASS BUSHING,
22	A.R.	CEMENT, NON-SHRINK GROUT
23	1	2" DRESSER COUPLING 6" LONG
24	2	BORE DONUTS 6" x 10"
25	1	REINFORCED CONCRETE TOP, PRE-CAST
27	1	FLOOR DRAIN, 2" PVC
28	1	ELBOW, 90°, 2" PVC LONG SWEEP
29	A.R.	PIPE, 2" PVC, SDR 21
30	2	BORE DONUTS 2" x 6"
31	2	2" AWWA GATE VALVE, R.H.T., FIPT, W/ 2" OPERATING NUT
32	2	PRESSURE GAUGE W/ 1/4" BRASS SHUTOFF VALVE AND BRASS BUSHING TO FIT
33	2	MAINLINE "E-Z" FLANGED ADAPTER, PVC-O.D., EBAA IRON SERIES 8500, OAE
34	A.R.	PLASTIC COATED STEEL OR ALUMINUM STEP
36	1	6" x 3/4" I.P. SADDLE, DOUBLE STRAP BRASS, W/ 3/4" CORPORATION STOP, I.P. MIPT x FIPT, 3/4" x 1/4" BUSHING
37	1	6" x 2" SADDLE I.P., DOUBLE STRAP BRASS W/ 2" CORPORATION STOP, BALL, MIPT x FIPT, 2" CLOSE MIPPLE, G.I., 2' THREADED TEE W/ 2" THREADED PLUG, 2" x 3/4" BUSHING W/ 3/4" x 1/4" BUSHING

DESIGNED BY:	NTUA
SURVEYED BY:	
DRAWN BY:	NTUA
APPROVED BY:	NTUA
DATE:	04/08
PROJECT NO.	
SCALE:	NTS
ACAD FILENAME:	Water Standard
DWG. NO.	WS-9a.DWG

**NAVAJO TRIBAL UTILITY AUTHORITY**  
By One Department Authority  
**MATERIAL LIST: 6" x 2"**  
**METER ON 8" WATER LINE**  
BY: ENGINEERING FT. DEFENCE, AZ

REVISIONS			
No.	Date	Brief	By
01	04/08	Revised	L.H.
02			
03			
04			
05			
06			



## TABLE OF CONTENTS

---

NO.	DESCRIPTION	FILE NO.
1.	WS-1 1" WATER SERVICE FOR A 5/8" x 3/4" OR 1" METER	3
2.	WS-1a MATERIAL LISTING: 1" SERVICE WITH 5/8" x 3/4" METER	4
3.	WS-1b MATERIAL LIST: 1" SERVICE WITH 1" METER	5
4.	WS-1c GENERAL NOTES FOR WATER SERVICE	6
5.	WS-1d PROPOSED INDIVIDUAL INSTALLATION	7
6.	WS-1e INDIVIDUAL AS-BUILT	8
7.	WS-1f VICINITY LOCATION OF NEW SERVICE	9
8.	WS-2 2" WATER SERVICE W/2" METER	10
9.	WS-2a MATERIAL LIST: 2" WATER SERVICE W/2" METER	11
10.	WS-3 2" MAINLINE TAP FOR SERVICES IN EXCESS OF 200'	12
11.	WS-3a MATERIAL LIST; 2" TAP FOR SERVICES IN EXCESS OF 200'	13
12.	WS-4 YARD HYDRANT SERVICE	14
13.	WS-4a MATERIAL LIST: YARD HYDRANT SERVICE	15
14.	WS-5 6" x 2" PRV	16
15.	WS-5a MATERIAL LIST: 6" x 2" PRV	17
16.	WS-6 3" W-350 DRS TURBO METER: FLOW RATE 5-350 GPM	18
17.	WS-6a MATERIAL LIST: 3" W-350 DRS TURBO METER	19
18.	WS-7 4" W-1000 DRS TURBO METER: FLOW RATE 15-1000 GPM	20
19.	WS-7a MATERIAL LIST: 4" W-1000 DRS TURBO METER	21
20.	WS-8 4" x 2" METER ON 6" WATER LINE (NON-TRAFFIC AREA)	22
21.	WS-8a MATERIAL LIST: 4" x 2" METER ON 6" WATER LINE	23
22.	WS-9 6" x 2" METER ON 8" WATERLINE (NON-TRAFFIC AREA)	24
23.	WS-9a MATERIAL LIST: 6" x 2" METER ON 8" WATERLINE	25
24.	WS-10 AIR RELEASE VALVE DETAIL	26
25.	WS-11 2" FLUSH VALVE DETAIL	27
26.	WS-12 FIRE HYDRANT AND GUARD DETAIL	28
27.	WS-12a MATERIAL LIST: FIRE HYDRANT AND GUARD	29
28.	WS-13 MARKER POST DETAILS	30
29.	WS-14 WATER MAIN VALVE INSTALLATION	31
30.	WS-15 TRENCH DETAIL	32
31.	WS-16 WATER MAIN TAP W/GATE VALVE	33
32.	WS-17a TYPICAL ROAD CROSSING FOR WATERLINES	34
33.	WS-17b TYPICAL ROAD CROSSING FOR WATERLINES	35
34.	WS-18 INSTALLATION OF SKIDS INSIDE CASING	36
35.	WS-19 GRAVITY/THRUST BLOCK DETAILS	37
36.	WS-19a GRAVITY/THRUST BLOCK CHART	38
37.	WS-20 WATER & SEWER CROSSING SEPARATION	39
38.	WS-21 STANDARD LEGEND	40

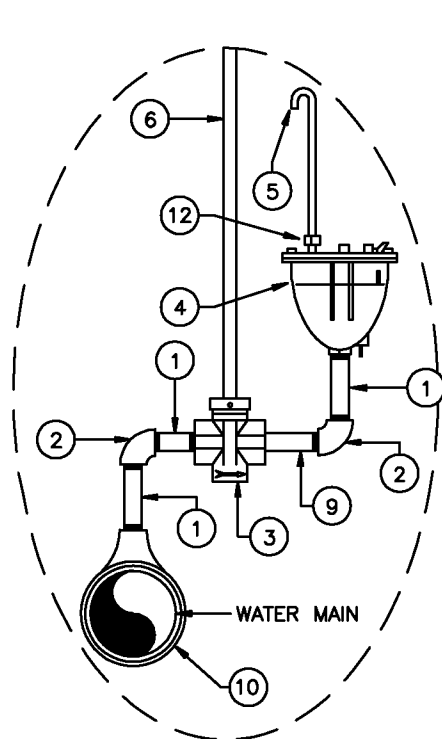

DETAIL "A"

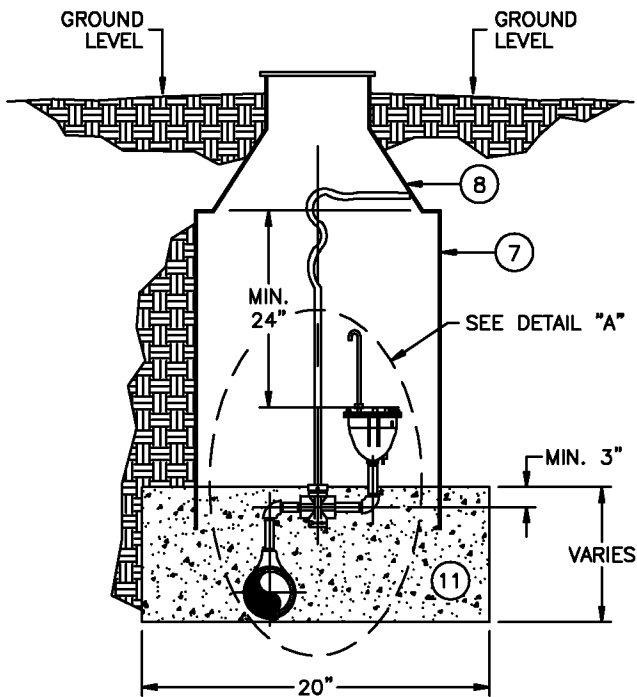

MATERIAL LIST		
ITEM	QUAN	DESCRIPTION
1	3	3/4" x 3" NIPPLE, BRASS
2	2	3/4" x 90° ELBOW, BRASS
3	1	3/4" CURB STOP VALVE, FIPT, MUELLER H-10287, OAE
4	1	3/4" IN x 3/8" OUT AIR RELEASE VALVE
5	1	3/8" O.D. PIPE, COPPER, 12" MIN.
6	1	STATIONARY ROD, 42"
7	1	METER CAN, 20" O.D. x 30" DEPTH, SONOLOC
8	1	METER CAN COVER W/ DOUBLE LID (FROST PLATE) FOR 20" O.D. CAN, CASTING M-70
9	1	3/4" x 6" NIPPLE, BRASS
10	1	SADDLE, BRASS, 3/4" TAP x APPROPRIATE PIPE O.D. SIZE
11	3 CF*	1" TO 2" FILTER ROCK
12	1	ADAPTER, 3/8" MIPT x 1/2" COMPRESSION

\*CF = CUBIC FEET

DESIGNED BY:	NTUA
SURVEYED BY:	
DRAWN BY:	NTUA
APPROVED BY:	NTUA
DATE:	04/08
PROJECT NO.	
SCALE:	NTS
ACAD FILENAME:	Water Standard
DWG. NO.	WS-10.DWG

**NAVAJO TRIBAL UTILITY AUTHORITY**  
By One Department Authority  
**AIR RELEASE VALVE DETAIL**  
BY: JPH/CH/ER/MS

REVISIONS			
No.	Date	Brief	By
01	04/08	Revised	L.H.
02			
03			
04			
05			
06			





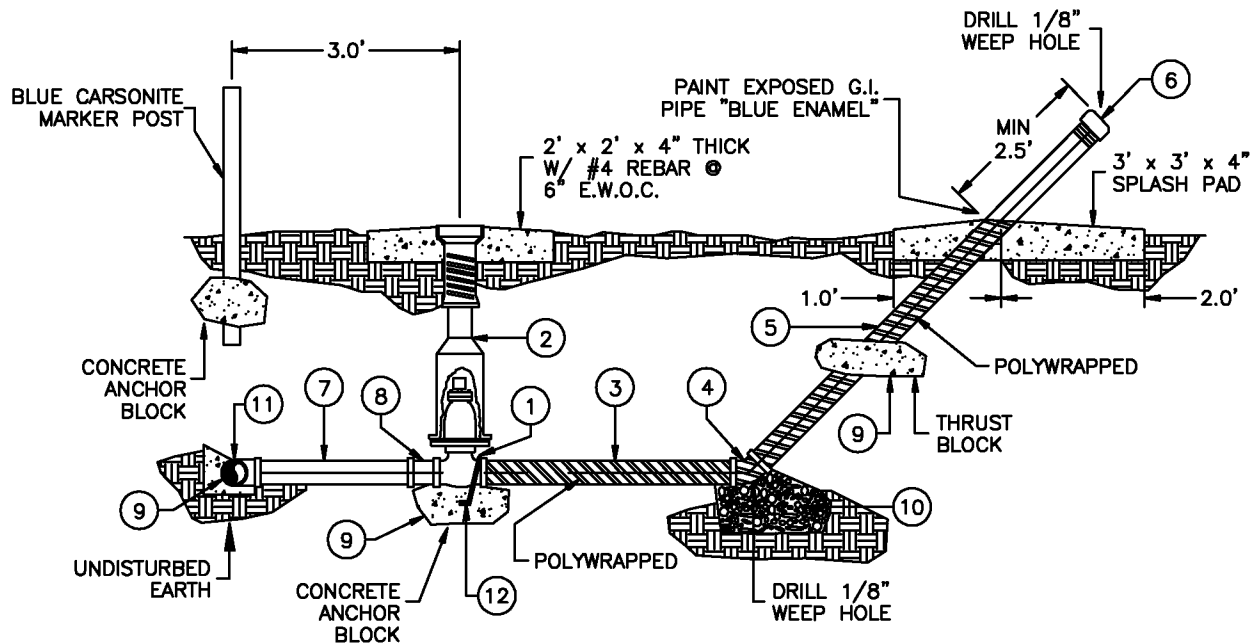

MATERIAL LIST

ITEM	QUAN	DESCRIPTION
1	1	2' GATE VALVE, C.I., FIPT, RW, NRS, RHT, W/ 2' OPERATING NUT, MUELLER A-2360-37
2	1	VALVE BOX, SCREW-TYPE, C.I., 2 PIECE, 5 1/4" SHAFT, TYLER 6850
3	1	2" x 3' PIPE (MIN.), G.I., COATED OR POLYWRAPPED
4	1	2" x 45° ELBOW, G.I., W/ 1/8" WEEP HOLE
5	1	2" PIPE, G.I. x CUT TO LENGTH AS NEEDED
6	1	2" CAP, G.I. W/ 1/8" VENT HOLE
7	1	2" PIPE, PVC CUT TO LENGTH AS NEEDED
8	1	2" ADAPTER, PVC, SLIP-GASKET x MIPT, SDR-21
9	A.R.	CONCRETE THRUST BLOCK, (DO NOT COVER JOINTS OR BOLTS), MIN. 1.5 CUBIC FEET
10	1.5 CF	CLEAN GRAVEL
11	1	MAIN LINE SADDLE OR TEE
12	A.R.	#4 REBAR

DESIGNED BY:	NTUA
SURVEYED BY:	
DRAWN BY:	NTUA
APPROVED BY:	NTUA
DATE:	04/08
PROJECT NO.	
SCALE:	NTS
ACAD FILENAME:	Water Standard
DWG. NO.	WS-11.DWG

**NAVAJO TRIBAL UTILITY AUTHORITY**  
By One Department Agreement  
**2" FLUSH VALVE DETAIL**  
EQ-REVISIONS

REVISIONS			
No.	Date	Brief	By
01	04/08	Revised	L.H.
02			
03			
04			
05			
06			



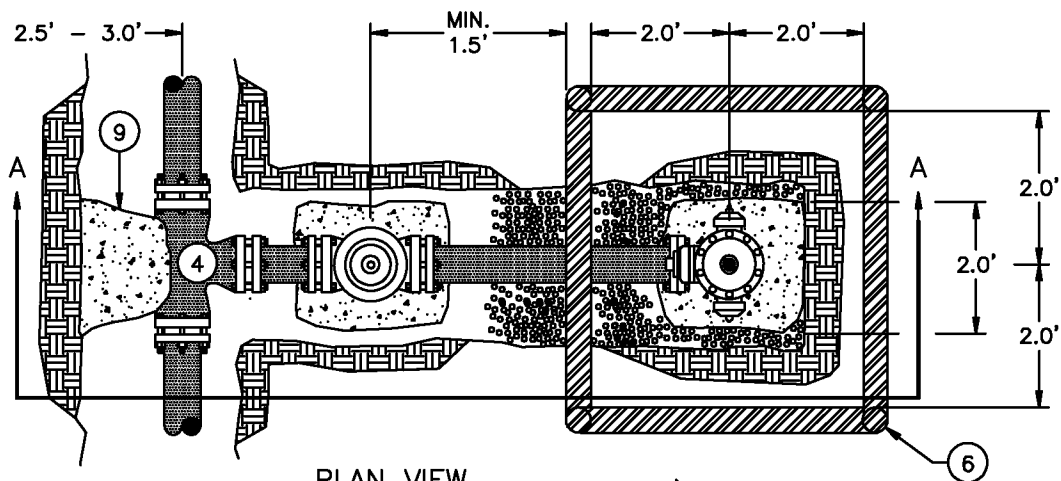

PLAN VIEW

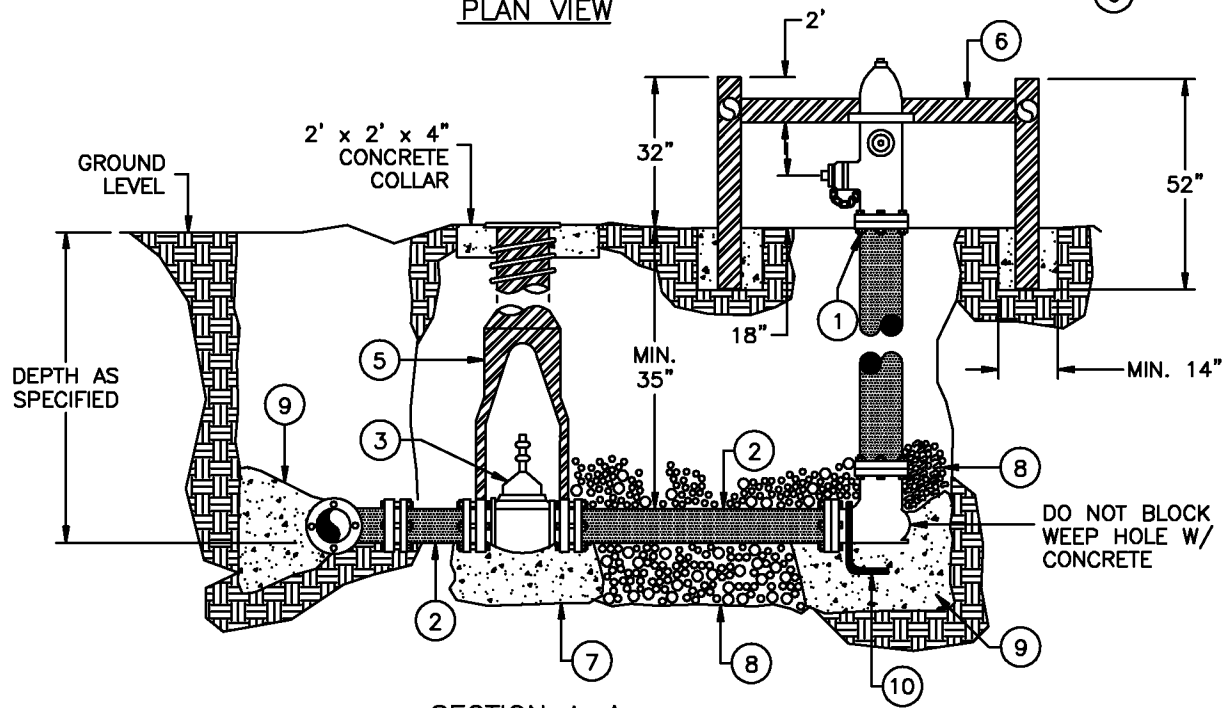

SECTION A-A

NOTES:

1. THE DETERMINATION OF THE APPROPRIATENESS OF A BARRICADE WILL BE MADE ON A CASE BY CASE BASIS.
2. CONTRACTOR MAY SUBSTITUTE A COMBINATION OF SERIES 2000 PV MEGALUG GLANDS AND SERIES 6500 JOINTS RETAINERS (EBAA IRON) FOR HYDRANT CONCRETE BLOCKING.
3. HYDRANT GUARD TO BE AT MINIMUM, SCHEDULE 40 STEEL.
4. PAINT GUARD RAIL WITH RED EXTERIOR ENAMEL AND FILL HYDRANT GUARD "POSTS" WITH CONCRETE.

DESIGNED BY:	NTUA
SURVEYED BY:	
DRAWN BY:	NTUA
APPROVED BY:	NTUA
DATE:	04/08
PROJECT NO.	
SCALE:	NTS
ACAD FILENAME:	Water Standard
DWG. NO.	WS-12.DWG

**NAVAJO TRIBAL UTILITY AUTHORITY**  
By Order: [Signature]  
**FIRE HYDRANT AND GUARD DETAIL**  
BSQ-REVISIONS

REVISIONS			
No.	Date	Brief	By
01	04/08	Revised	L.H.
02			
03			
04			
05			
06			



**MATERIAL LIST**

ITEM	QTY	DESCRIPTION
1	1	HYDRANT, 4" BURY W/ TRAFFIC FLANGE & 1 - 4 1/2" PUMPER CONNECTION (A) 2 - 2 1/2" HOSE CONNECTION (B) MUELLER A423 OR KENNEDY K81A W/ 5 1/4" VALVE M.J.
2	2	6" PVC PIPE, LENGTH AS NEEDED, 200 PSI, SDR-21
3	1	6" M.J. GATE VALVE, NRS, RSW, RHT, 2" OPERATION NUT
4	1	M.J. TEE AS REQUIRED, M.J. 6" BRANCH
5	1	GATE VALVE BOX, 5 1/4" W/ CAST IRON LID, LID TYLER 6850
6	1	HYDRANT GUARD, 36 LINEAR FEET 4" Ø BLACK STEEL PIPE #0765
7	A.R.	CONCRETE, 1.5 CUBIC FEET MIN. (DON'T COVER JOINTS AND BOLTS)
8	A.R.	CRUSHED ROCK 1" TO 2" DIAMETER
9	A.R.	CONCRETE THRUST BLOCK, (SEE NTUA STANDARDS FOR TEE)
10	1	#4 REBAR TIE HOOP

**NOTES:**

1. A.R. = AS REQUIRED

DESIGNED BY:	NTUA
SURVEYED BY:	
DRAWN BY:	NTUA
APPROVED BY:	NTUA
DATE:	04/08
PROJECT NO.	
SCALE:	NTS
ACAD FILENAME:	Water Standard
DWG. NO.	WS-12a.DWG

**NAVAJO TRIBAL UTILITY AUTHORITY**  
By One Department Agreement  
**MATERIAL LIST: FIRE  
 HYDRANT AND GUARD**

80-8900000000
PT.DEPANCE, AZ

REVISIONS			
No.	Date	Brief	By
01	04/08	Revised	L.H.
02			
03			
04			
05			
06			



DESIGNED BY:	NTUA
SUPERSEDED BY:	
DRAWN BY:	NTUA
APPROVED BY:	NTUA
DATE:	04/09
PROJECT NO.:	
SCALE:	N.T.S.
ADD FILENAME:	Water-Standard
DWG. NO.:	WS-13DWG

NAVJO TRIBAL UTILITY AUTHORITY  
 In Cooperation with Navajo Nation  
**MARKER POST  
 DETAILS**  
 7/14/2014, AS

REVISIONS	
No.	Date

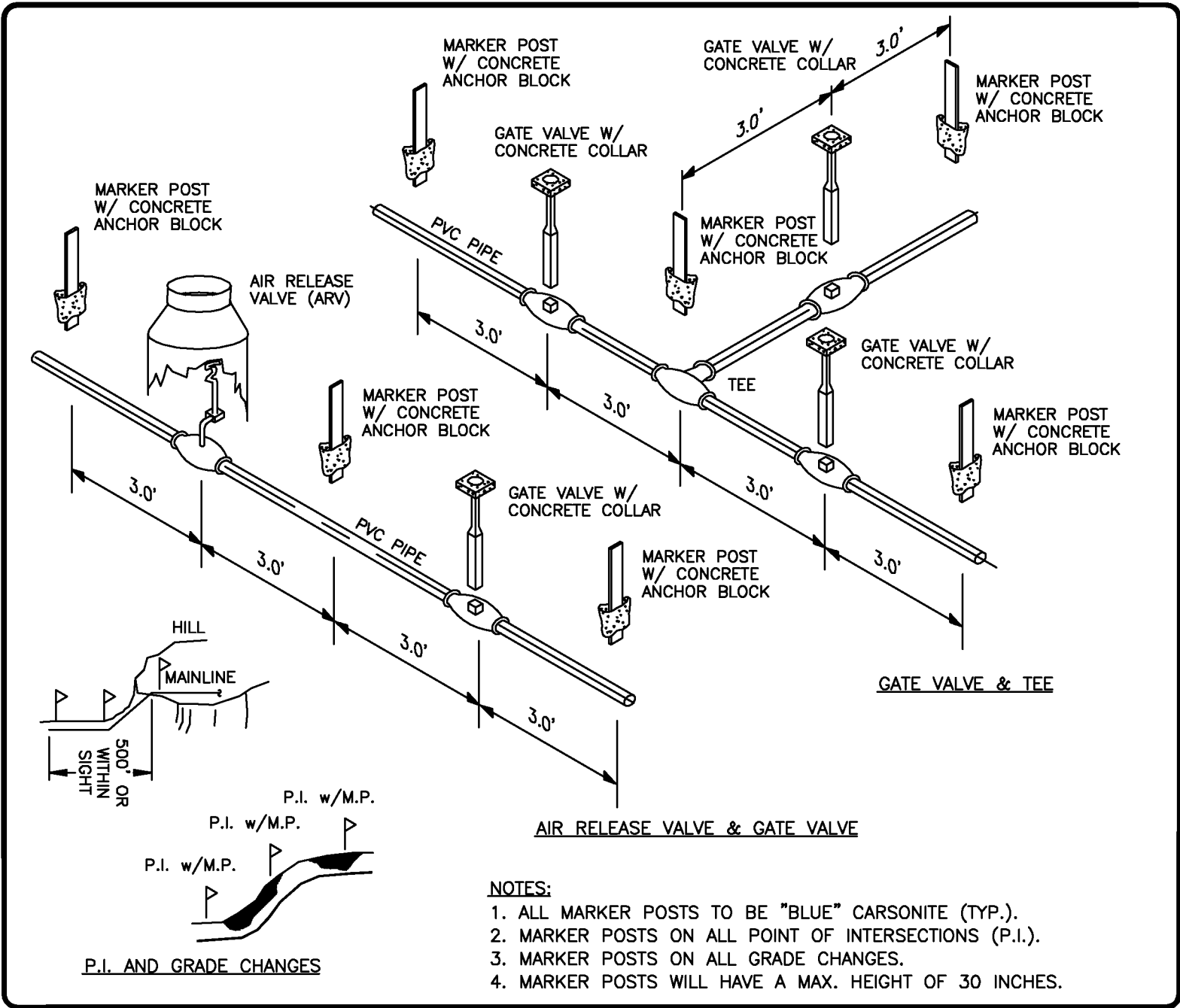

- NOTES:**
1. ALL MARKER POSTS TO BE "BLUE" CARSONITE (TYP.).
  2. MARKER POSTS ON ALL POINT OF INTERSECTIONS (P.I.).
  3. MARKER POSTS ON ALL GRADE CHANGES.
  4. MARKER POSTS WILL HAVE A MAX. HEIGHT OF 30 INCHES.

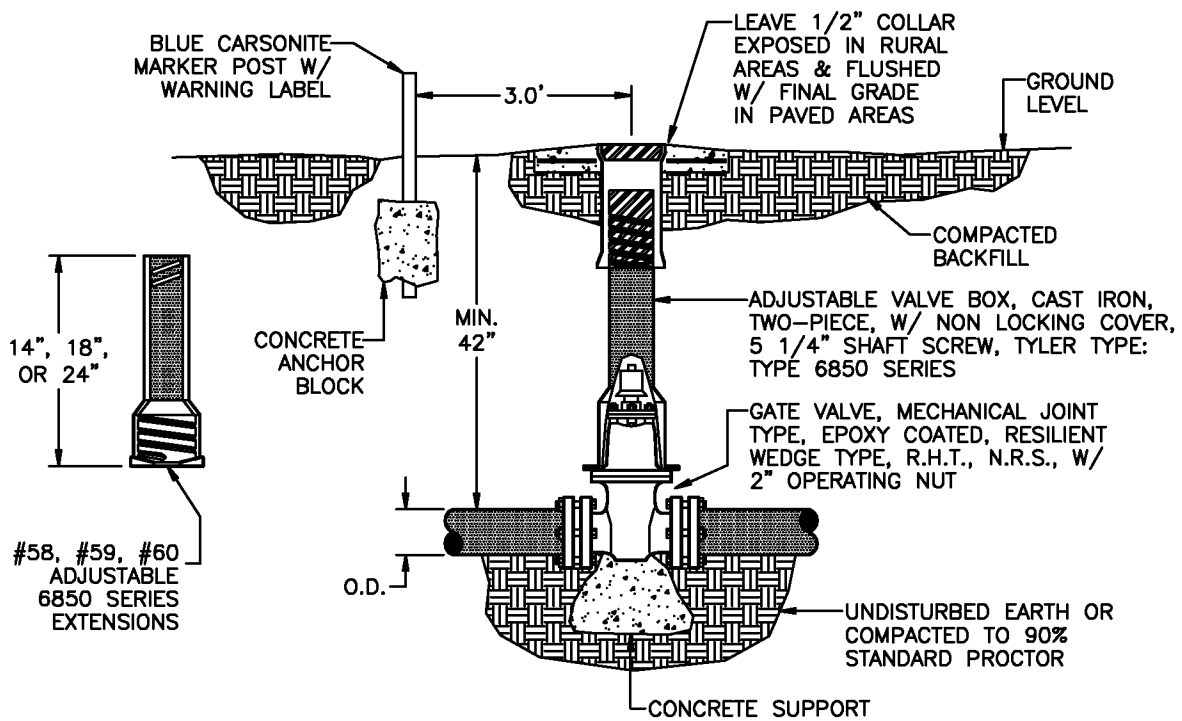
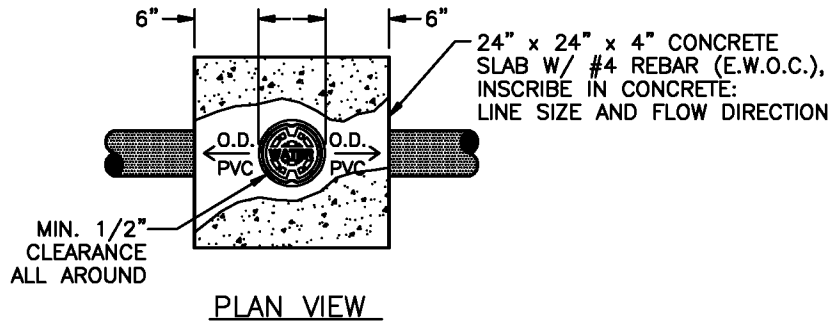

**NOTES:**

1. IF APPROPRIATE, USE SERIES 2000 PV MEGALUG GLANDS FOR SDR-21, PVC TO SECURE GATE VALVE(S) TO OTHER FITTINGS/PIPE, USE OTHER MEGALUGS FOR DIFFERENT OUTSIDE DIAMETER PIPE/TYPE.
2. DO NOT COVER JOINTS AND BOLTS WITH CONCRETE.
3. SEE WS-13 FOR APPROPRIATE LOCATION OF MARKER POST.

DESIGNED BY:	NTUA
SURVEYED BY:	
DRAWN BY:	NTUA
APPROVED BY:	NTUA
DATE:	04/08
PROJECT NO.	
SCALE:	NTS
ACAD FILENAME:	Water Standard
DWG. NO.	WS-14.DWG

**NAVAJO TRIBAL UTILITY AUTHORITY**  
By One Department  
**WATER MAIN VALVE  
 INSTALLATION**

EQ-ENGINEERING
PT.DISTANCE, AZ

REVISIONS			
No.	Date	Brief	By
01	04/08	Revised	L.H.
02			
03			
04			
05			
06			



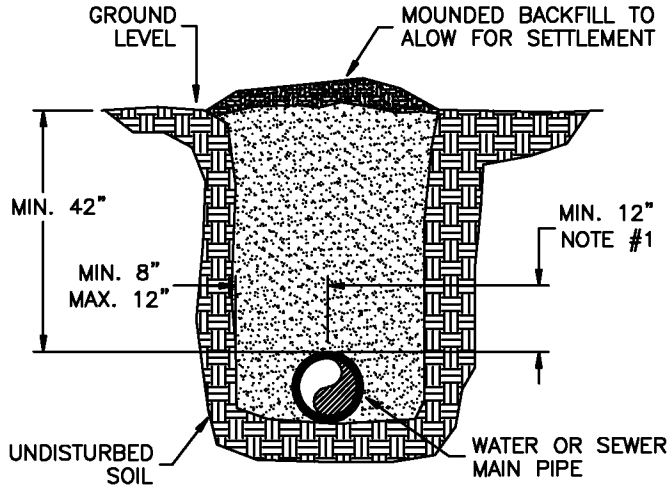

TYPICAL TRENCH DETAIL

NOTES:

1. HAND COMPACTED IN 6" LIFTS FROM BOTTOM OF TRENCH TO 12" ABOVE PIPE CROWN.
2. OPEN CUT OR PAVED OR GRAVEL ROADS (IF REQUIRED), BACK FILL MINIMUM COMPACTION 95% OPTIMUM DENSITY IN LIFTS.
3. REPAVING AND REGRAVELING WILL BE DONE TO ROAD OWNER'S REQUIREMENTS.
4. KEEP LOWER 5' OF TRENCH WALL VERTICAL IF POSSIBLE. UPPER PART OF THE TRENCH WILL VARY IN WIDTH TO COMPENSATE FOR UNSTABLE SOIL. APPLICABLE O.S.H.A. REQUIREMENTS SHALL BE MET.

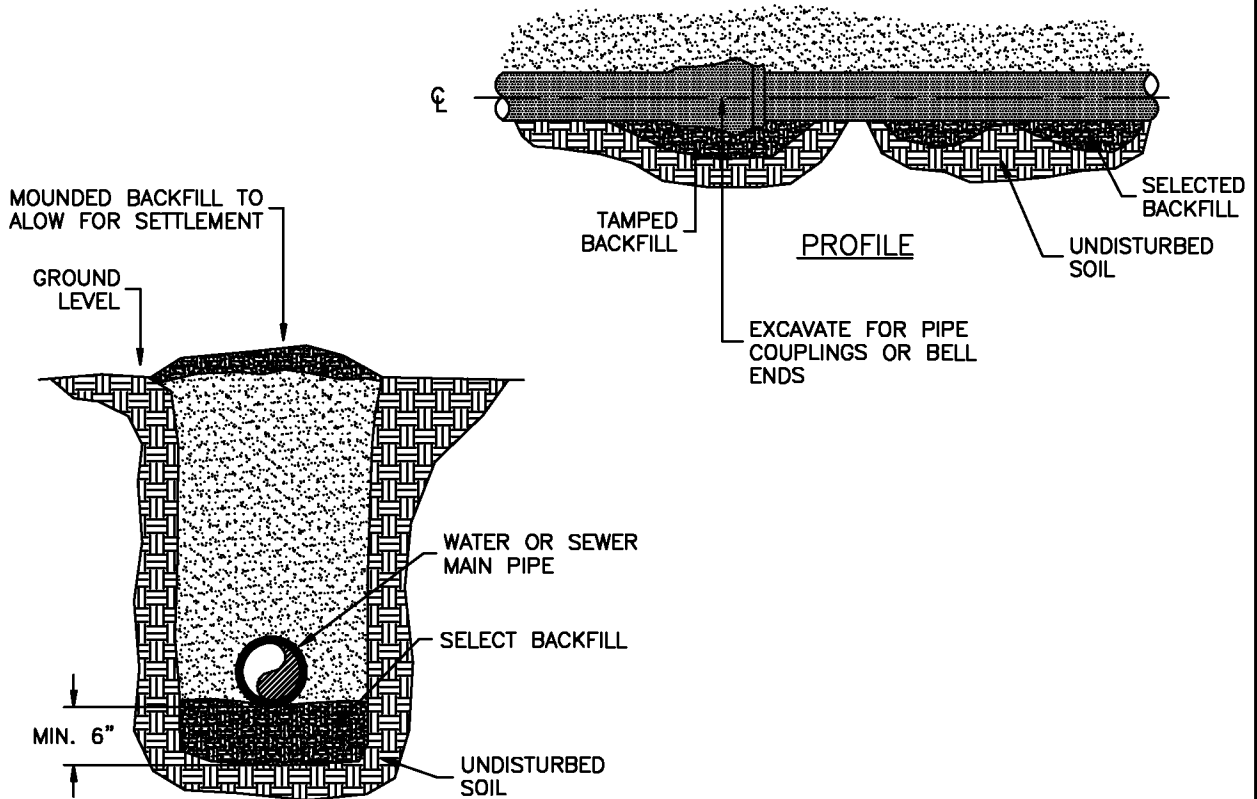

ALTERNATE TRENCH DETAIL

DESIGNED BY:	NTUA
SURVEYED BY:	
DRAWN BY:	NTUA
APPROVED BY:	NTUA
DATE:	04/08
PROJECT NO.:	
SCALE:	NTS
ACAD FILENAME:	Water Standard
DWG. NO.:	WS-15.DWG

**NAVAJO TRIBAL UTILITY AUTHORITY**  
By One Department  
**TRENCH DETAIL**  
BY: ENGINEERING FT. DEFENCE, AZ

REVISIONS			
No.	Date	Brief	By
01	04/08	Revised	L.H.
02			
03			
04			
05			
06			



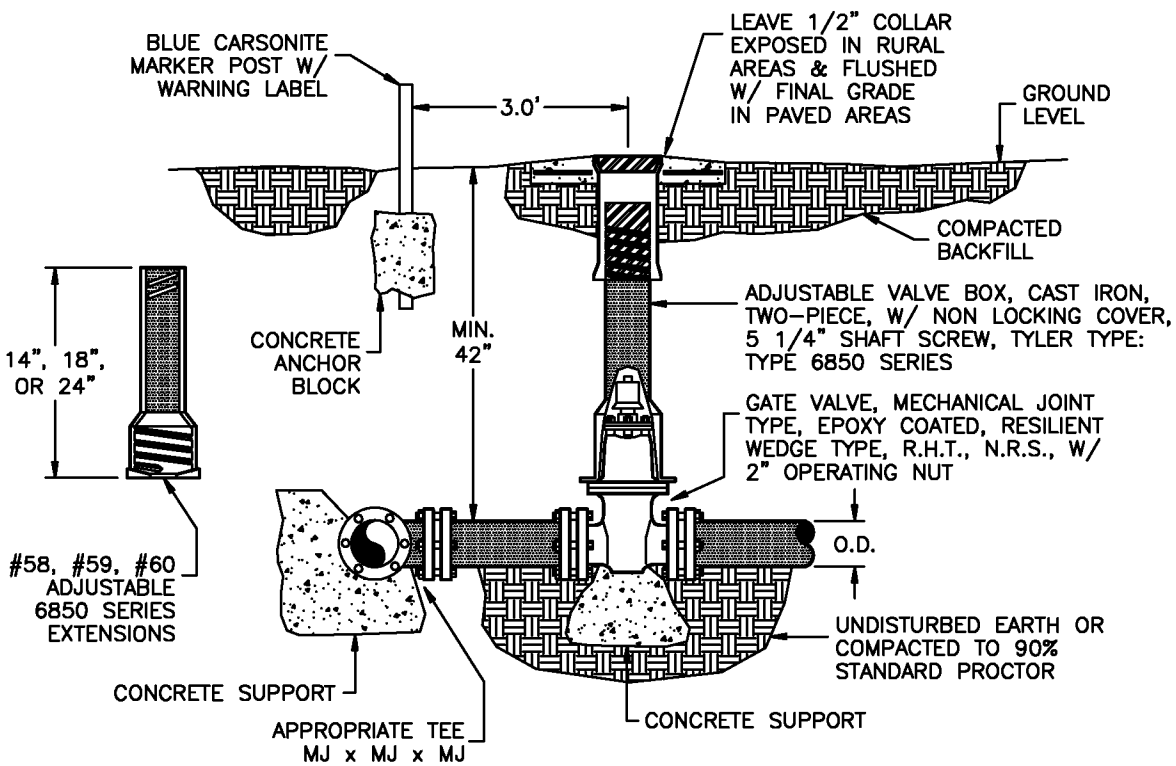
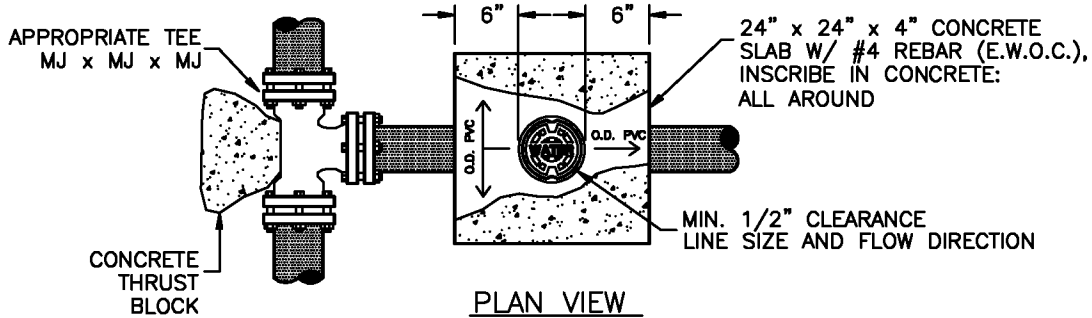

**NOTES:**

1. IF APPROPRIATE, USE SERIES 2000 PV MEGALUG GLANDS FOR SDR-21, PVC TO SECURE GATE VALVE(S) TO OTHER FITTINGS/PIPE, USE OTHER MEGALUGS FOR DIFFERENT OUTSIDE DIAMETER PIPE/TYPE.
2. DO NOT COVER JOINTS AND BOLTS WITH CONCRETE.
3. SEE WS-13 FOR APPROPRIATE LOCATION OF MARKER POST.

DESIGNED BY:	NTUA
SURVEYED BY:	
DRAWN BY:	NTUA
APPROVED BY:	NTUA
DATE:	04/08
PROJECT NO.:	
SCALE:	NTS
ACAD FILENAME:	Water Standard
DWG. NO.:	WS-16.DWG

NAVAJO TRIBAL UTILITY AUTHORITY  
By Order of the Navajo Tribal Council

**WATER MAIN TAP  
W/GATE VALVE**

EQ-ENGINEERING FT.DENVER, CO

REVISIONS			
No.	Date	Brief	By
01	04/08	Revised	L.H.
02			
03			
04			
05			
06			



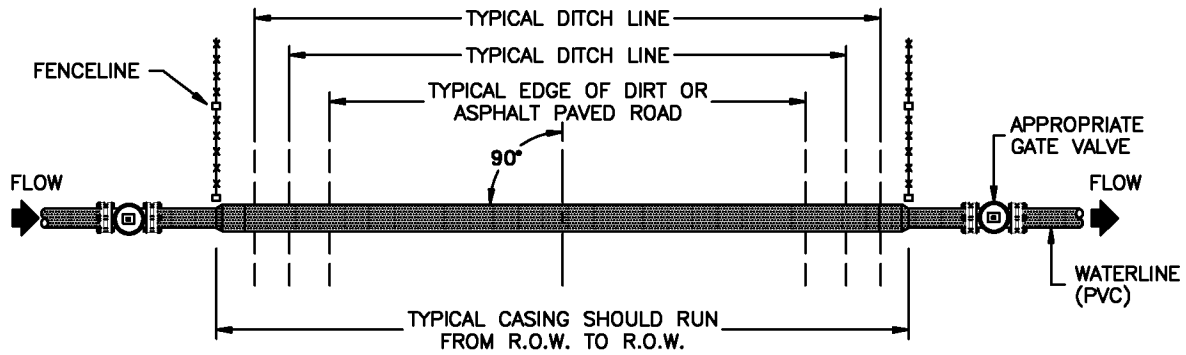

CASING PLAN VIEW

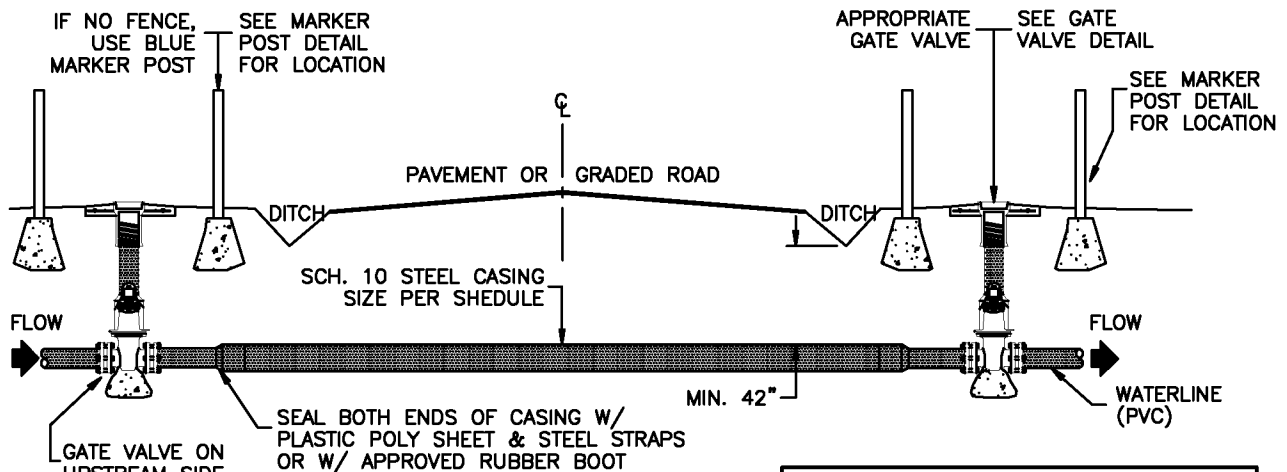

CASING PROFILE VIEW

MINIMUM CASING SIZE	
PIPE SIZE (O.D.)	CASING SIZE (I.D.)
4"	12"
6"	14"
8"	16"
10"	18"
12"	20"
14"	22"

**NOTES:**

1. ALL CASINGS WILL TYPICALLY RUN FROM ROW TO ROW UNLESS OTHERWISE SPECIFIED.
2. BACKFILL SHALL BE 95% OF STANDARD PROCTOR DENSITY – TESTED IN 6" LIFTS.
3. ALL WOOD SKIDS ARE TO BE REDWOOD GRADE OR APPROVED EQUAL (OAE)
4. ALL SKIDS WILL BE SECURELY FASTENED TO PIPE WITH STAINLESS STEEL STRAPS.
5. ROAD SHALL BE BORED UNDER EXISTING PAVEMENT AND OPEN TRENCH ON REMAINDER, UNLESS OTHERWISE SPECIFIED.
6. IF SYSTEM IS LOOPED FOR A ROAD BORING APPLICATION, INSTALL GATE VALVE ON UPSTREAM AND DOWNSTREAM SIDES OF ROADWAY.
7. DUCTILE IRON SHALL BE CLASS 50.
8. DUCTILE IRON ROAD CROSSING IN B.I.A. RURAL AREAS SHALL BE FROM 10' BEYOND DITCH LINE UNLESS OTHERWISE SPECIFIED.

DESIGNED BY:	NTUA
SURVEYED BY:	
DRAWN BY:	NTUA
APPROVED BY:	NTUA
DATE:	04/08
PROJECT NO.	
SCALE:	NTS
ACAD FILENAME:	Water Standard
DWG. NO.	WS-17a.DWG

**NAVAJO TRIBAL UTILITY AUTHORITY**  
By One Department Structure  
**TYPICAL ROAD CROSSING FOR NTUA WATERLINES**  
REQ-REVISIONS

REVISIONS			
No.	Date	Brief	By
01	04/08	Revised	L.H.
02			
03			
04			
05			
06			





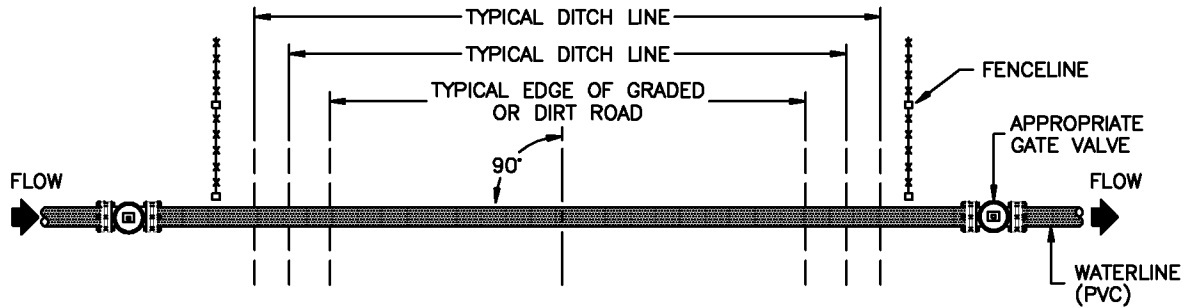

DUCTILE-IRON CROSSING PLAN VIEW

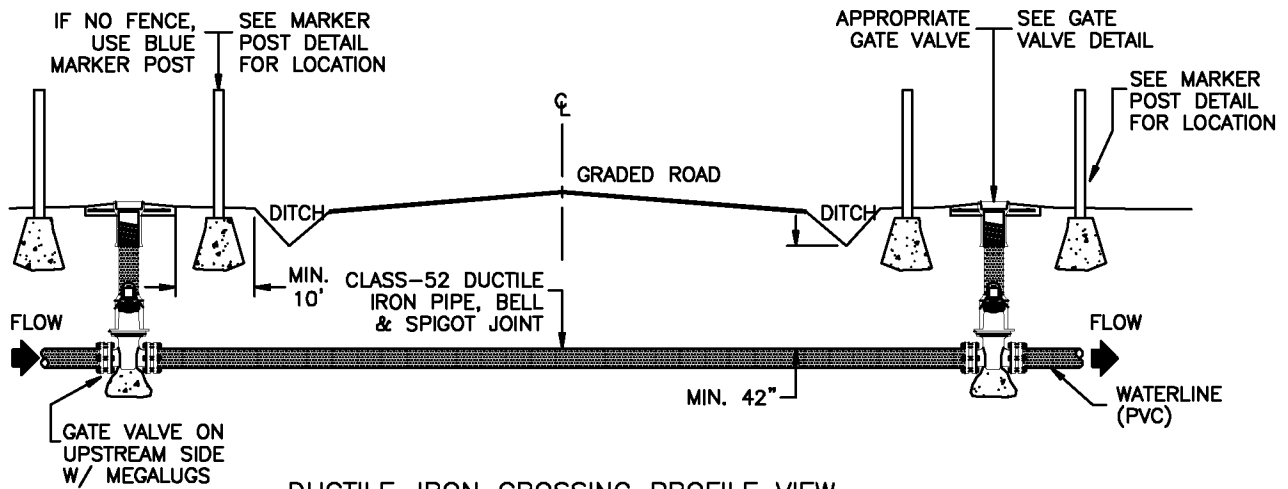

DUCTILE-IRON CROSSING PROFILE VIEW

NOTES:

1. ALL CASINGS WILL TYPICALLY RUN FROM ROW TO ROW, UNLESS OTHERWISE SPECIFIED.
2. BACKFILL SHALL BE 95% OF STANDARD PROCTOR DENSITY - TESTED IN 6" LIFTS.
3. ALL WOOD SKIDS ARE TO BE REDWOOD GRADE OR APPROVED EQUAL (OAE)
4. ALL SKIDS WILL BE SECURELY FASTENED TO PIPE WITH STAINLESS STEEL STRAPS.
5. ROAD SHALL BE BORED UNDER EXISTING PAVEMENT AND OPEN TRENCH ON REMAINDER, UNLESS OTHERWISE SPECIFIED.
6. IF SYSTEM IS LOOPED FOR A ROAD BORING APPLICATION, INSTALL GATE VALVE ON UPSTREAM AND DOWNSTREAM SIDES OF THE ROADWAY.
7. DUCTILE IRON SHALL BE CLASS 52.
8. DUCTILE IRON ROAD CROSSING IN B.I.A. RURAL AREAS SHALL BE FROM 10' BEYOND DITCH LINE UNLESS OTHERWISE SPECIFIED.

DESIGNED BY:	NTUA
SURVEYED BY:	
DRAWN BY:	NTUA
APPROVED BY:	NTUA
DATE:	04/08
PROJECT NO.	
SCALE:	NTS
ACAD FILENAME:	Water Standard
DWG. NO.	WS-17b.DWG

**NAVAJO TRIBAL UTILITY AUTHORITY**  
By Order of the Board of Directors

**TYPICAL ROAD CROSSING  
FOR NTUA WATERLINES**

800-899-0808      FT. DEFENCE, AZ

REVISIONS			
No.	Date	Brief	By
01	04/08	Revised	L.H.
02			
03			
04			
05			
06			



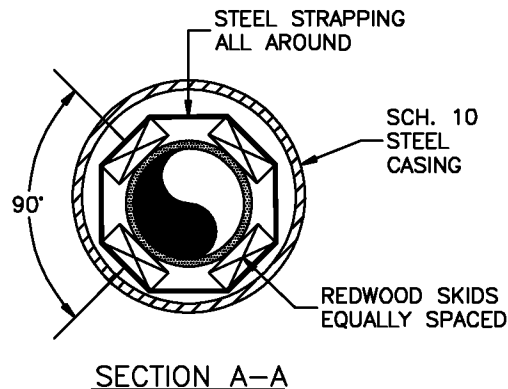
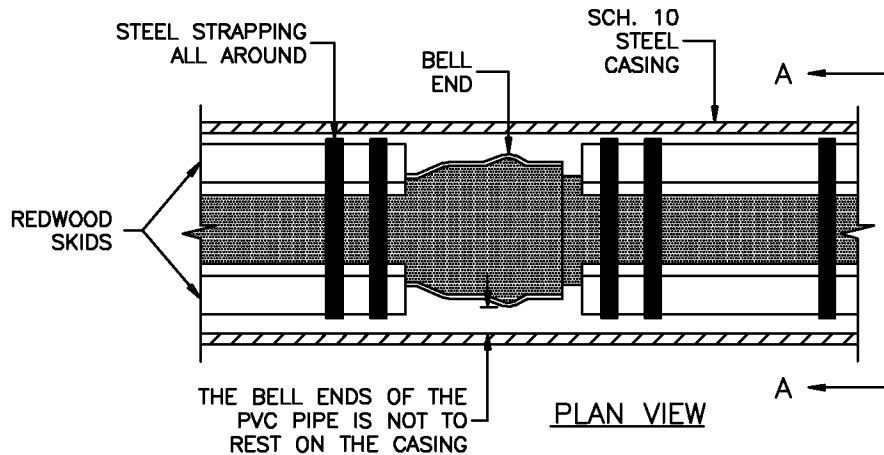

**NOTES:**

1. ALL SKIDS SHALL RUN THE LENGTH OF THE PVC PIPE, BELL TO BELL.
2. ALL SKIDS TO BE REDWOOD LUMBER, OR APPROVED EQUAL.
3. BELL AND SPIGOT DUCTILE IRON PIPE MAY BE INSTALLED DIRECTLY WITHIN THE CASING.
4. TYPICAL ROAD BORES BY NAVAJO ENGINEERING AND CONSTRUCTION AUTHORITY ARE 8" AND 14" CASING SIZES.
5. ALL STRAPPING MUST BE STAINLESS STEEL AND BE SECURELY FASTENED TO THE PVC CARRIER PIPE FOR PROPER SUPPORT OF PIPE DURING INSTALLATION.
6. SEAL ENDS OF CASING W/ PLASTIC POLY SHEET AND STAINLESS STEEL STRAPS OR AN APPROVED RUBBER BOOT.

MINIMUM CASING SIZE	
PIPE SIZE (O.D.)	CASING SIZE (I.D.)
4"	12"
6"	14"
8"	16"
10"	18"
12"	20"
14"	22"

DESIGNED BY:	NTUA
SURVEYED BY:	
DRAWN BY:	NTUA
APPROVED BY:	NTUA
DATE:	04/08
PROJECT NO.	
SCALE:	NTS
ACAD FILENAME:	Water Standard
DWG. NO.	WS-18.DWG

**NAVAJO TRIBAL UTILITY AUTHORITY**  
By One Department Authority  
**INSTALLATION OF SKIDS  
 INSIDE CASING**

EQ-ENGINEERING
PT.DISTANCE, AZ

REVISIONS			
No.	Date	Brief	By
01	04/08	Revised	L.H.
02			
03			
04			
05			
06			



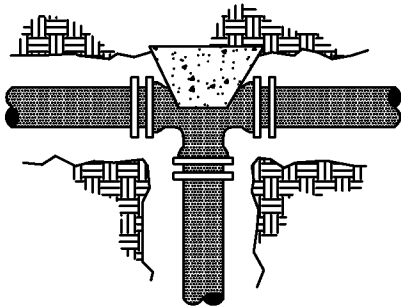

TEE  
(PLAN VIEW)

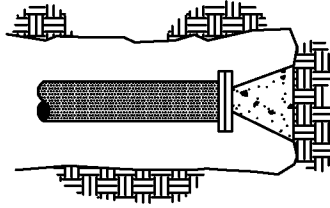

DEAD END CAPPED OR PLUG  
(PLAN VIEW)

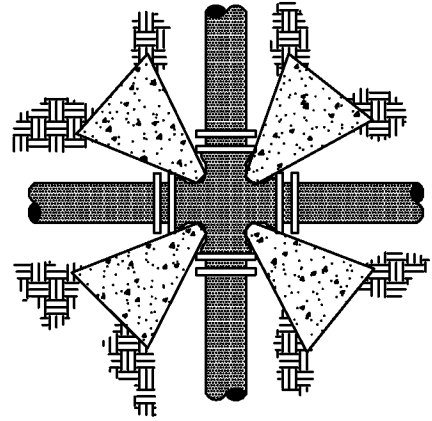

CROSS  
(PLAN VIEW)

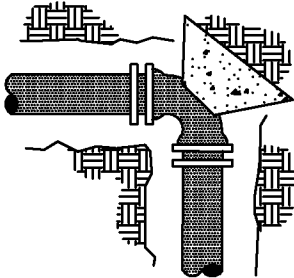

90° ELBOW  
(PLAN VIEW)

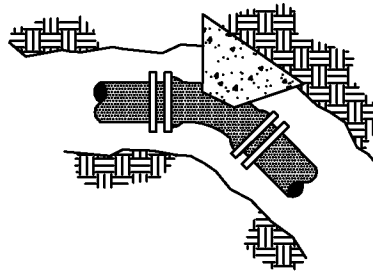

45° ELBOW  
(PLAN VIEW)

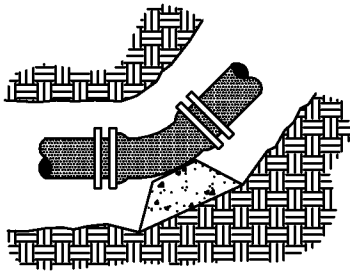

VERTICAL BENDS  
(SECTION VIEW)

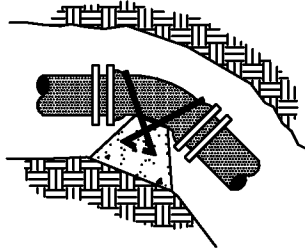

VERTICAL GRAVITY THRUST BLOCK  
(SECTION VIEW)

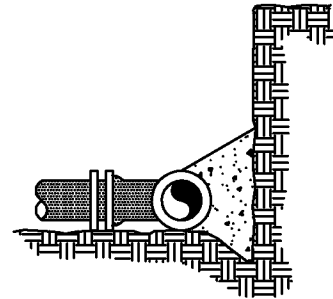

BEARING AREA  
(SECTION VIEW)

NOTES:

1. DO NOT COVER GASKETED JOINTS AND NUTS/BOLTS.

MINIMUM BEARING AREAS IN SQUARE FEET

PIPE SIZE	TEE & PLUG	90° ELBOW	45° OR 22 1/2° ELBOW	CROSS
2"	0.5	0.5	0.5	0.5
4"	1.5	2.0	1.5	1.0
6"	3.0	4.5	2.5	2.0
8"	5.0	7.5	4.0	4.0
10"	8.0	11.0	6.5	5.5
12"	11.0	15.5	9.0	8.0
14"	15.0	21.0	12.0	10.5
16"	19.0	27.0	15.5	13.5
18"	24.0	34.0	19.0	17.0

DESIGNED BY:	NTUA
SURVEYED BY:	
DRAWN BY:	NTUA
APPROVED BY:	NTUA
DATE:	04/08
PROJECT NO.	
SCALE:	NTS
ACAD FILENAME:	Water Standard
DWG. NO.	WS-19.DWG

**NAVAJO TRIBAL UTILITY AUTHORITY**  
By One Department Agreement  
**GRAVITY/THRUST**  
**BLOCK DETAILS**  
EQ-REVISIONS

REVISIONS			
No.	Date	Brief	By
01	04/08	Revised	L.H.
02			
03			
04			
05			
06			



**GRAVITY THRUST BLOCK**  
 (ALSO TO BE USED IN UNSTABLE TRENCH CONDITIONS)  
 RESULTANT THRUST IN POUNDS OF FITTINGS AT 100 PSI WATER PRESSURE

TOTAL POUNDS					
PIPE SIZE	DEAD END	90° ELBOW	45° ELBOW	22 1/2° ELBOW	11 1/4° ELBOW
3"	1,232	1,742	943	481	241
4"	1,810	2,559	1,385	706	355
6"	3,739	5,288	2,862	1,459	733
8"	6,433	9,097	4,923	2,510	1,261
10"	9,677	13,685	7,406	3,776	1,897
12"	13,685	19,353	10,474	5,340	2,683
14"	18,385	26,001	14,072	7,174	3,604
16"	23,799	33,628	18,199	9,278	4,661
18"	29,865	42,235	22,858	11,653	5,855
20"	36,644	51,822	28,046	14,298	7,183
24"	52,279	73,934	40,013	20,398	10,249
30"	80,425	113,738	61,554	31,380	15,766
36"	115,209	162,931	88,177	44,952	22,585
42"	155,528	219,950	119,036	60,684	30,489
48"	202,683	286,637	155,127	79,083	39,733
54"	260,214	367,999	199,160	101,531	51,011
60"	298,121	421,606	228,172	116,321	58,442
64"	338,707	479,004	259,235	132,157	66,398

**NOTES:**

1. THE THRUST (IN TOTAL POUNDS) IN THE CHART IS BASED ON DUCTILE IRON OUTSIDE DIAMETER PIPE DIMENSION. SURGES SHOULD BE CONSIDERED AT TWICE THE NORMAL OPERATING PRESSURE. THE VOLUME OF THE GRAVITY THRUST BLOCK IS BASED ON CONCRETE AT 150 LBS./FT<sup>3</sup>.
2. TO OBTAIN VOLUME OF CONCRETE REQUIRED, USE:  

$$\text{VOLUME OF CONCRETE(FT}^3\text{)} = \text{THRUST(LBS.)} \times \text{SYSTEM PRESSURE(PSI)} / 100 \text{ PSI} // 150 \text{ LBS./FT}^3.$$
 E.G.: CALCULATE THE VOLUME OF THE GRAVITY THRUST BLOCK FOR AN 8" x 45' BEND AT AN OPERATING PRESSURE OF 80 PSI.  
  
 ANSWER: 4923 LBS. x 160 PSI/100 PSI DIVIDED BY 150 LBS./CUBIC FT. = 52.5 CUBIC FEET OR 2 CUBIC YARDS.

DESIGNED BY:	NTUA
SURVEYED BY:	
DRAWN BY:	NTUA
APPROVED BY:	NTUA
DATE:	04/08
PROJECT NO.:	
SCALE:	NTS
ACAD FILENAME:	Water Standard
DWG. NO.:	WS-19a.DWG

**NAVAJO TRIBAL UTILITY AUTHORITY**  
By One Department Agreement

**GRAVITY/THRUST  
BLOCK CHART**

80-REVISIONS FT.DISTANCE, AS

REVISIONS			
No.	Date	Brief	By
01	04/08	Revised	L.H.
02			
03			
04			
05			
06			



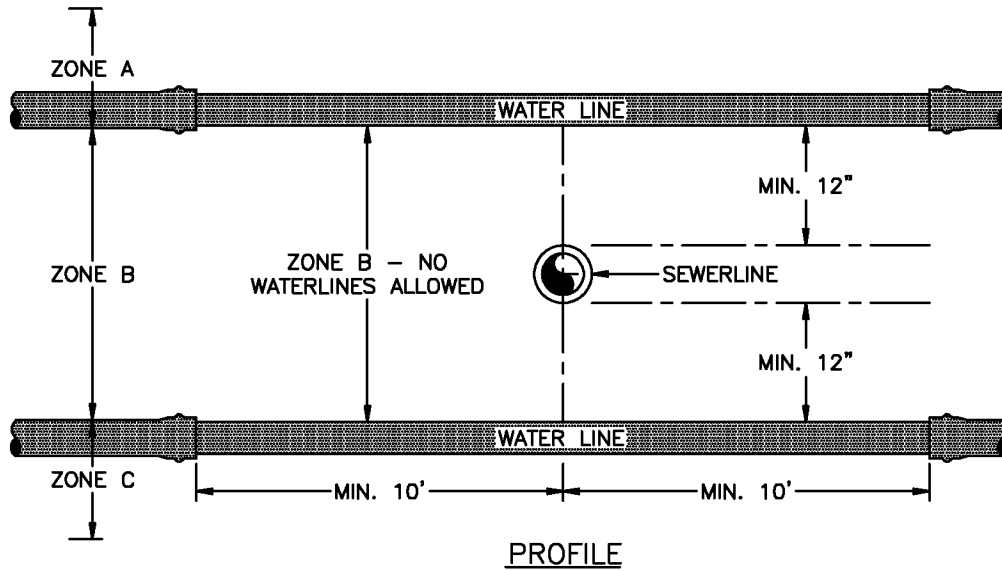

ZONE A - THE BOTTOM OF THE WATER LINE SHALL BE 12" OR MORE ABOVE THE TOP OF THE SEWER LINE - NO SPECIAL PRECAUTIONS REQUIRED.

ZONE B - 12' ABOVE AND 12' BELOW SEWER LINE - NO WATER LINES ALLOWED.

ZONE C - THE TOP OF THE WATER LINE SHALL BE 12" OR MORE BELOW THE BOTTOM OF THE SEWER LINE. IF THE SEWER LINE IS A NEWLY CONSTRUCTED SEWER LINE, AN 18" LENGTH OF DUCTILE IRON SEWER PIPE W/ GASKETED JOINTS SHALL BE CENTERED OVER THE WATER LINE WITH NO JOINTS CLOSER THAN 9' TO THE WATER LINE IN EACH DIRECTION. IF THE WATER LINE IS IN ZONE C AND THE WATER MAIN IS A NEWLY CONSTRUCTED WATER LINE, A 20' LENGTH OF PVC WATER PIPE SHALL BE CENTERED UNDER THE SEWER LINE.

**NOTES:**

1. WHEN POSSIBLE, WATER LINES SHALL BE INSTALLED ABOVE SEWER LINES AND CROSSINGS SHALL BE AT 90° ANGLE(S).
2. WHEN WATER AND SEWER LINES ARE INSTALLED PARALLEL TO EACH OTHER, THE MINIMUM HORIZONTAL SEPERATION SHALL BE 10'.

DESIGNED BY:	NTUA
SURVEYED BY:	
DRAWN BY:	NTUA
APPROVED BY:	NTUA
DATE:	04/08
PROJECT NO.	
SCALE:	NTS
ACAD FILENAME:	Water Standard
DWG. NO.	WS-20.DWG

**NAVAJO TRIBAL UTILITY AUTHORITY**  
By One Department  
**WATER AND SEWER**  
**CROSSING SEPERATION**

80-8900000000      PT.DEPANANCE, AZ

REVISIONS			
No.	Date	Brief	By
01	04/08	Revised	L.H.
02			
03			
04			
05			
06			



## LEGEND

	EXISTING WATER MAIN W/ LINE SIZE, TYPE, & PSI RATING INDICATED
	PROPOSED WATERLINE W/ SIZE TYPE, & PSI RATING INDICATED
	EXISTING SEWER MAIN W/ SIZE, TYPE, & LENGTH INDICATED
	PROPOSED SEWER MAIN W/ SIZE, TYPE, & LENGTH INDICATED
	HOUSE W/ CUSTOMER NAME AND/OR HOUSE NUMBER
	SEPTIC TANK
	FENCELINE
	PAVED OR GRADED ROAD
	UNIMPROVED ROAD
	ARCHAEOLOGICAL SITE
	WASH OR ARROYO
	PRESSURE REDUCING VALVE (VAULT)
	AIR RELEASE VALVE
	DOMESTIC STOP
	FIRE HYDRANT W/ GATE VALVE
	CLEANOUT
	GATE VALVE
	CURB STOP
	METER
	PROPOSED SEWERLINE & MANHOLE W/ FLOW DIRECTION
	EXISTING SEWER LINE & MANHOLE W/ FLOW DIRECTION
	REDUCER
	OVERHEAD ELECTRIC LABEL WITH JNC-TEP FOR TELEPHONE JNC-CATV FOR CABLE TV (JNC IS JOINT NAVAJO COMMUNICATION)
	UNDERGROUND ELECTRIC
	LINE CROSSING
	METER W/ INDIVIDUAL PRV
	FLUSH VALVE
	GAS LINE
	MARKER POST
	YARD HYDRANT
	INFILTRATORS

DESIGNED BY:	NTUA
SURVEYED BY:	
DRAWN BY:	NTUA
APPROVED BY:	NTUA
DATE:	04/08
PROJECT NO.	
SCALE:	NTS
ACAD FILENAME:	Water Standard
DWG. NO.	WS-21.DWG

**NAVAJO TRIBAL UTILITY AUTHORITY**  
By One Department

## STANDARD LEGEND

BQ-REVISIONS      FT.DISTANCE, AS

REVISIONS			
No.	Date	Brief	By
01	04/08	Revised	L.H.
02			
03			
04			
05			
06			



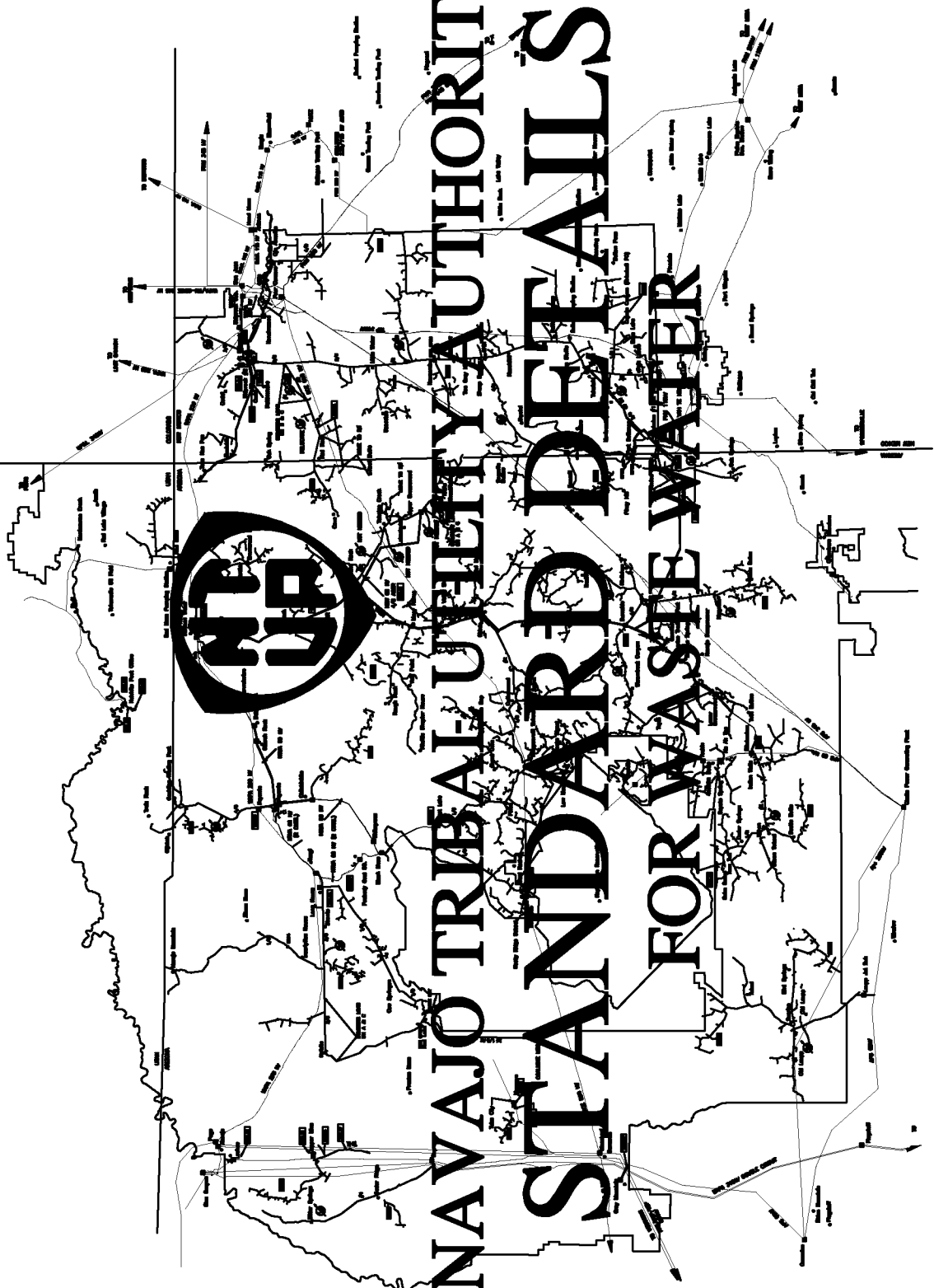

# NAVAJO TRIBAL UTILITY AUTHORITY STANDARD DETAILS FOR WASTE WATER

## TABLE OF CONTENTS

---

NO.	DESCRIPTION	FILE NO.
1.	WWS-1 4" STANDARD SEWER SERVICE LINE	3
2.	WWS-1a MATERIAL LISTING: 4" STANDARD SEWER SERVICE	4
3.	WWS-1b GENERAL NOTES FOR SEWER SERVICE LINE	5
4.	WWS-1c PROPOSED INDIVIDUAL INSTALLATION	6
5.	WWS-1d INDIVIDUAL AS-BUILT	7
6.	WWS-1e VICINITY LOCATION OF NEW SERVICE	8
7.	WWS-2 SHALLOW PRECAST MANHOLE DETAIL	9
8.	WWS-3 DROPPED MANHOLE DETAIL	10
9.	WWS-4 STANDARD PRECAST SEWER MANHOLE DETAIL	11
10.	WWS-5 STANDARD MANHOLE RING AND COVER	12
11.	WWS-6 STANDARD MANHOLE STEPS	13
12.	WWS-7 GREASE TRAP DETAIL	14
13.	WWS-8 WATER & SEWER CROSSING SEPERATION	15
14.	WWS-9 SEWER CROSSING & CONCRETE ENCASEMENT DETAIL	16
15.	WWS-10 STANDARD TRENCH DETAIL	17
16.	WWS-11 STANDARD 8" SEWER CLEANOUT DETAIL	18
17.	WWS-12 STANDARD 4" SEWER CLEANOUT DETAIL	19
18.	WWS-13 STANDARD 6" SEWER CLEANOUT DETAIL	20
19.	WWS-14 TYPICAL ROAD CROSSING FOR SEWERLINES	21
20.	WWS-15 STANDARD LEGEND	22



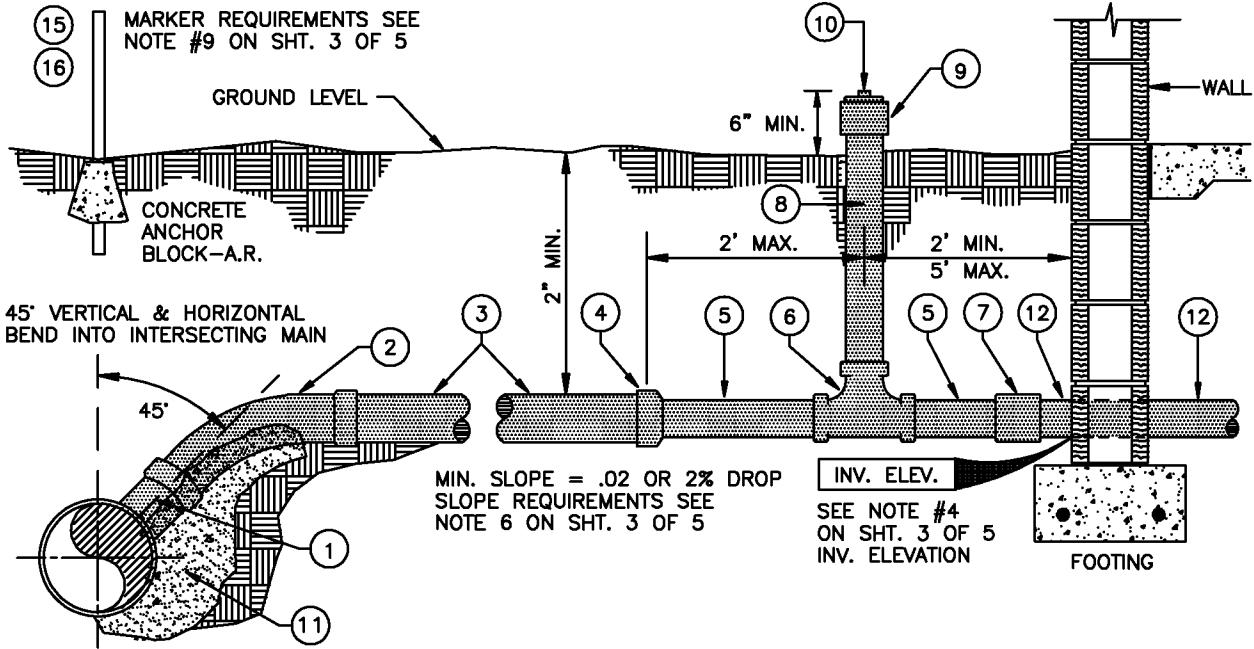

NOTE: NTUA DOES NOT MAINTAIN SEWER SERVICE LINES. THEY ARE THE CUSTOMERS RESPONSIBILITY.

AS-BUILT LOCATION OF TAP	
PROJECT NAME	
PROJECT NO.	
SHEET NO.	
LINE NO.	
STATION NO.	
INV. ELEVATION	
RELATED W.O. NO'S.	

INDEX	PAGES
4" SEWER SERVICE LINE	1 of 6
MATERIAL LIST	2 of 6
GENERAL NOTES	3 of 6
PROPOSED INDIVIDUAL INSTALLATION	4 of 6
INDIVIDUAL AS-BUILT	5 of 6
VICINITY LOCATION OF SERVICE	6 of 6

TESTED IN ACCORDANCE WITH THE NTUA TECHNICAL SPECIFICATIONS TP-4.08 THRU 4.10; DATED MARCH 2003.

BY: \_\_\_\_\_

NAME/TITLE: \_\_\_\_\_

DATE: \_\_\_\_\_

DESIGNED BY:	NTUA
SURVEYED BY:	
DRAWN BY:	NTUA
APPROVED BY:	NTUA
DATE:	3/08
PROJECT NO.	
SCALE:	NTS
ACAD FILENAME:	Waterwaste Standard
DWG. NO.	WWS-1

**NAVAJO TRIBAL UTILITY AUTHORITY**  
AN EQUAL OPPORTUNITY ORGANIZATION

**4" STANDARD SEWER SERVICE LINE**

EE-ENGINEERING FT. DEFENCE, AZ

REVISIONS			
No.	Date	Brief	By
01	3/08	REVISED	LH
02			
03			
04			
05			
06			



MATERIAL LIST		
ITEM	QUAN	DESCRIPTION
1	1	45° WYE or SADDLE, 4" SDR-35, PVC x APPROPRIATE PIPE TYPE and O.D.
2	1	4" x 45° ELBOW, SDR-35, PVC, GASKET x GASKET
3	A.R.	4" PIPE, SDR-35, PVC, INTEGRAL BELL with ELASTOMERIC GASKET. (FT.)
4	1	ADAPTER, REDUCING, 4" SDR-35, PVC, ASTM D-3034 x 3" PVC-DWV, ASTM D-2665
5	A.R.	3" PIPE, PVC-DWV, ASTM D-2665. (FT.)
6	1	3" TEE, PVC-DWV, HUB x HUB, ASTM D-2665 with a SINGLE RISER.
7	1	3" COUPLING, PVC-DWV, ASTM D-2665.
8	A.R.	3" RISER, PVC-DWV, ASTM D-2665. (FT.)
9	1	3" ADAPTER, HUB x FIPT, PVC-DWV, ASTM D-2665
10	1	3" PLUG, CLEAN OUT, MIPT, PVC-DWV, ASTM D-2665
11	1	CONCRETE, PRE-MIX, (FIELD DETERMINE AS REQUIRED FOR PIPE SUPPORT)
12	1	HOUSE STUB-OUT, APPROPRIATE PIPE TYPE and O.D.
13	1	CEMENT, SOLVENT, PVC. (QUART CAN)
14	1	CLEANER, PVC PIPE. (QUART CAN)
15	A.R.	GREEN CARSONITE MARKER POST
16	A.R.	"NTUA SEWERLINE WARNING" DECAL (for Item 15) * *

NOTES:

1. A.R. = AS REQUIRED
2. ITEM 12 IS USUALLY DONE BY THE HOME OWNER.
3. ITEM 7 MAY BE MODIFIED AS REQUIRED.
4. DECAL TO BE AFFIXED TO ITEM 15\*\*.

SHEET 2 OF 6

DESIGNED BY:	NTUA
SURVEYED BY:	
DRAWN BY:	NTUA
APPROVED BY:	NTUA
DATE:	3/08
PROJECT NO.	
SCALE:	NTS
ACAD FILENAME:	Waterwaste Standard
DWG. NO.	WWS-1a

<b>NAVAJO TRIBAL UTILITY AUTHORITY</b> <small>IN THE DISTRICT OF COLUMBIA</small>	
<b>MATERIAL LIST 4"</b> <b>STANDARD SEWER SERVICE</b>	
<small>EEG-ENGINEERING</small>	<small>PT.DIFFIANCE, AS</small>

REVISIONS			
No.	Date	Brief	By
01	3/08	Revised	L.H.
02			
03			
04			
05			
06			



GENERAL NOTES:

1. PROVIDE 10 FT. MINIMUM HORIZONTAL SEPARATION IN SEPARATE TRENCHES BETWEEN THE WATER AND SEWER SERVICES. PROVIDE 5 FT. MIN. HORIZONTAL SEPARATION BETWEEN THE SEWER SERVICE AND OTHER UTILITIES. IF SEWER SERVICE CROSSES OTHER SERVICES, SEE N.T.U.A CROSSING POLICY OR CONTACT N.T.U.A. HEADQUARTERS ENGINEERING.
2. SEWER CLEANOUTS ARE REQUIRED ON ALL BENDS IN EXCESS OF 45° AS PER PLUMBING CODE ADOPTED BY THE NAVAJO NATION. MODIFY MATERIAL LIST ACCORDINGLY AFTER CONSULTING WITH N.T.U.A. HEADQUARTERS ENGINEERING.
3. ADDITIONAL SEWER CLEANOUTS ARE REQUIRED ON SEWER SERVICES LONGER THAN 50 FT. AS PER UNIFORM PLUMBING CODE ADOPTED BY THE NAVAJO NATION. MODIFY MATERIAL LIST ACCORDINGLY AFTER CONSULTING WITH N.T.U.A. HEADQUARTERS ENGINEERING. EACH ADDITIONAL CLEANOUT IS AT THE CUSTOMERS EXPENSE INSTALL AT LEAST ONE CLEANOUT AS REQUIRED BY NOTE 2. IF CUSTOMER REQUEST FEWER AND REALIZES THIS VIOLATES NAVAJO TRIBAL CODE, THEN INSTALL PER THE CUSTOMER'S REQUEST AND SO NOTE ON THE INDIVIDUAL AS-BUILT, N.T.U.A. RECOMMENDS THAT CLEANOUTS BE SPACED NO MORE THAN 100'.
4. PROVIDE PROPOSED ELEVATION AT WALL. PROVIDE 6 IN. DIAMETER SLEEVE IF PIPING PENETRATES WALL OR 4 IN. DEPTH OF SAND BETWEEN FOOTING AND TOP OF PIPING IS BELOW THE FOOTING. ORDER ASTM D-1785 SCH. 40 PIPE WITH LENGTH AS NEEDED FOR THE SLEEVE. CONTACT N.T.U.A. HEADQUARTERS ENGINEERING ON PIPING SMALLER THAN 2 IN. IN SIZE.
5. STATE THE EXISTING PIPE TYPE AND O.D. (e.g. ASTM D-3034, SDR 35, PVC, 8. 40"). SADDLE IS TO HAVE A GASKET SEAL OR O-RING AND NON-CORRODIBLE STRAP SECURING SYSTEM.
6. MINIMUM SLOPE OF 1/4 INCH PER FOOT (2%) OR CONTACT N.T.U.A. HEADQUARTERS ENGINEERING.
7. BACKFILL IS TO BE HAND TAMPED (NO-MECHANICAL) AND COMPACTED IN 6 INCH LAYERS FOR AT LEAST 12 IN. ABOVE PVC PIPE. INSTALL PER ASTM D-2321 AND UNIFORM PLUMBING CODE ADOPTED BY THE NAVAJO NATION.
8. PROVIDE THE AS-BUILT AND SWING TIES FOR THE TAP POINT.
9. THE MATERIAL LIST SHALL BE MODIFIED IF A FIELD MARKER OF THE TAP POINT IS TO BE INSTALLED. UNDER THE AS-BUILT TIE INFORMATION. PROVIDE THE SURFACE DESCRIPTION OF THE TAP POINT (e.g. OPEN FIELD, PAVED ROAD, etc)
10. ITEM 12 IS USUALLY DONE BY THE HOME OWNER. ITEM 7 MUST BE COMPATIBLE WITH ITEM 12. ITEM 7 AS LISTED IS FOR A CONNECTION BETWEEN TWO LENGTHS OF 3 IN. PVC-DWV ASTM D-2665. IN THE MATERIALS LIST, ITEM 12 NEEDS TO BE COMPLETED AND ITEM 7 MODIFIED AS REQUIRED.
11. ORDER CONCRETE AS NEEDED. THE CONCRETE MAY BE ELIMINATED IF N.T.U.A. DISTRICT WATER FOREMAN AND ENGINEER DETERMINE FIELD CONDITIONS DO NOT REQUIRE THIS FOR ADEQUATE COMPACTION AND 4 IN. PIPE STRUCTURAL SUPPORT. MARK THE AS-BUILT DRAWING TO SHOW WHEN THE CONCRETE IS NOT USED.
12. FOR MULTIPLE BENDS, A CLEANOUT IS REQUIRED UPSTREAM FROM THE FIRST BEND THAT CAUSED THE CUMULATIVE ANGLE TO EXCEED 45°.

DESIGNED BY:	NTUA
SURVEYED BY:	
DRAWN BY:	NTUA
APPROVED BY:	NTUA
DATE:	3/08
PROJECT NO.	
SCALE:	NTS
ACAD FILENAME:	Waterwaste Standard
DWG. NO.	WWS-1b

**NAVAJO TRIBAL UTILITY AUTHORITY**  
of the Navajo Nation  
**GENERAL NOTES**  
**SEWER SERVICE**























EQ-ENGINEERING      PT.DENAFANCE, AZ

REVISIONS			
No.	Date	Brief	By
01	3/08	Revised	L.H.
02			
03			
04			
05			
06			



(PLAN VIEW - NORTH ARROW REQUIRED)

\* SEE GENERAL NOTES NO. 11 ON SHEET 3 of 5

ITEM DESCRIPTION	MATERIALS			ITEM DESCRIPTION	MATERIALS		
	LEGEND	SIZE	TYPE		LEGEND	SIZE	TYPE
WATERLINE TAP 				WATERLINE, PROPOSED	-- W --		
VALVE, GATE 				WATERLINE, EXISTING	—W—		
VALVE, CURB STOP 				SEWERLINE, PROPOSED	-- S --		
WATER METER 				SEWERLINE, EXISTING	—S—		
WATER METER W/ IND PRV 				PROPOSED TIE INFORMATION			
VALVE, DOMESTIC STOP 							
YARD HYDRANT 				LOCATION:			
CLEAN-OUT(S) 				SYSTEM:			
SEPTIC TANK 				PROJECT NO:	SHT.	OF	SHTS.
INFILTRATORS 				DRAWN BY:	DATE:		
DWELLING/OTHER BLDGS 				PROPOSED START DATE:			

SHEET 4 OF 6

DESIGNED BY:	NTUA
SURVEYED BY:	
DRAWN BY:	NTUA
APPROVED BY:	NTUA
DATE:	3/08
PROJECT NO.	
SCALE:	NTS
ACAD FILENAME:	Waterwaste Standard
DWG. NO.	WWS-1c

**NAVAJO TRIBAL UTILITY AUTHORITY**  
AN EQUAL OPPORTUNITY ORGANIZATION  
**PROPOSED INDIVIDUAL  
INSTALLATION**































EEG-ENGINEERING
PT.DENFANCE, AZ

REVISIONS			
No.	Date	Brief	By
01	3/08	Revised	L.H.
02			
03			
04			
05			
06			



(PLAN VIEW - NORTH ARROW REQUIRED)

\* SEE GENERAL NOTES NO. 11 ON SHEET 3 of 5

ITEM DESCRIPTION	MATERIALS			SWING TIES (IN FEET)				CONSTRUCTION COST:
	LEGEND	SIZE	TYPE	NW(A)	NE(B)	SW(C)	SE(D)	
WATERLINE TAP 								MATERIAL:
VALVE, GATE 								LABOR:
VALVE, CURB STOP 								EQUIPMENT:
WATER METER 								TOTAL:
WATER METER W/ IND PRV 			*					
VALVE, DOMESTIC STOP 								
YARD HYDRANT 								
CLEAN-OUT(S) 								
SEPTIC TANK 								
INFILTRATORS 				AS-BUILT TIE INFORMATION				
DWELLING/OTHER BLDGS 				LOCATION:				
WATERLINE, PROPOSED 				SYSTEM:				
WATERLINE, EXISTING 				PROJECT NO:				
SEWERLINE, PROPOSED 				DRAWN BY:		DATE:		
SEWERLINE, EXISTING 				COMPLETION DATE:				

SHEET 5 OF 6

DESIGNED BY:	NTUA
SURVEYED BY:	
DRAWN BY:	NTUA
APPROVED BY:	NTUA
DATE:	3/08
PROJECT NO.	
SCALE:	NTS
ACAD FILENAME:	Waterwaste Standard
DWG. NO.	WWS-1d

**NAVAJO TRIBAL UTILITY AUTHORITY**  
AN EQUAL OPPORTUNITY ORGANIZATION  
**INDIVIDUAL**  
**AS-BUILTS**

EEG-ENGINEERING
PT.DENANCE, AZ

REVISIONS			
No.	Date	Brief	By
01	3/08	Revised	L.H.
02			
03			
04			
05			
06			





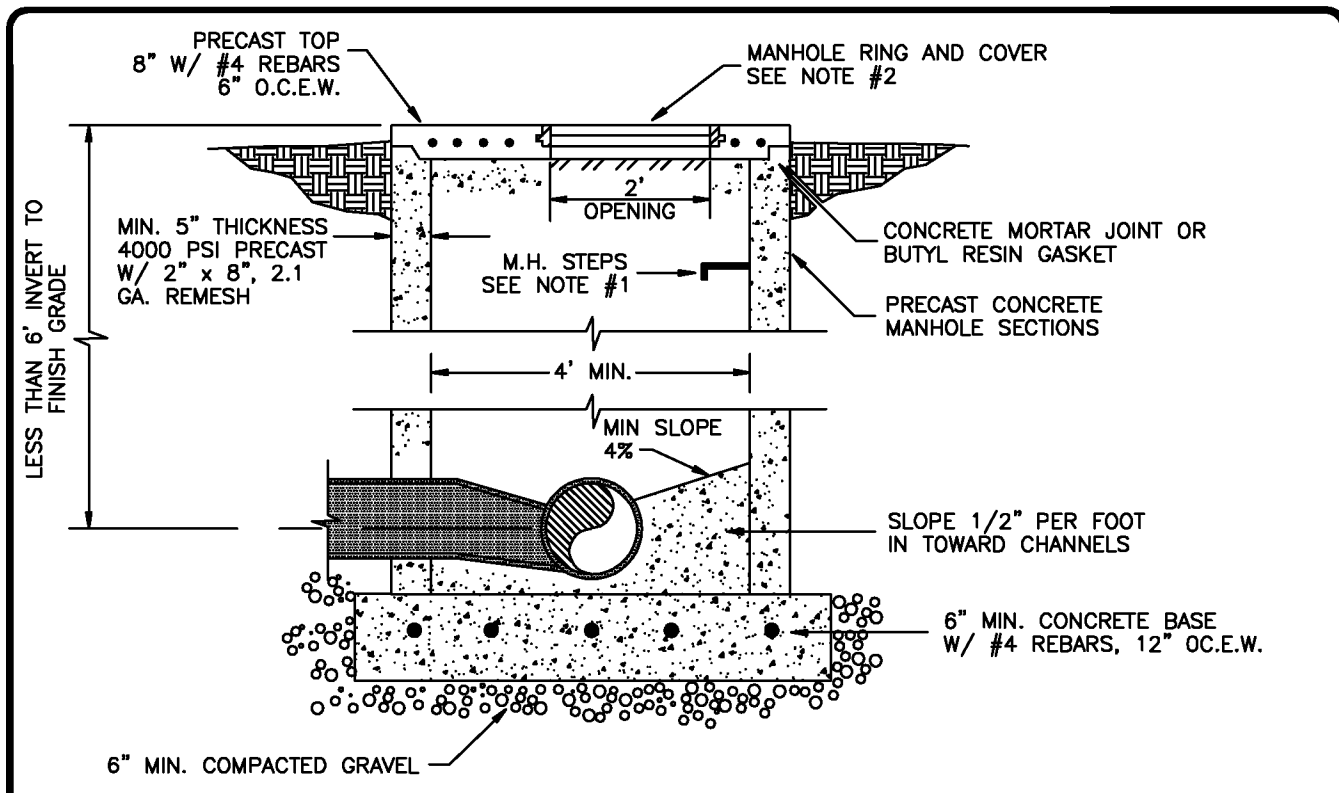

**NOTES:**

1. SEE STANDARD DRAWINGS OF MANHOLE STEPS, WWS-8
2. SEE STANDARD DRAWINGS OF MANHOLE RING AND COVER, WWS-7
3. ALL CONCRETE CHANNELS SHALL BE A MIN. OF 3000 PSI RICH-MIX.
4. GROUT ALL LIFTING HOLES.
5. INVERT ELEV., OUTLET ELEV., RIM ELEV., & DROP ELEV. SHOULD BE THE SAME SIZE AS SHOWN ON CONSTRUCTION DRAWINGS.
6. ALL STRUCTURAL CONCRETE SHALL BE 4000 PSI.

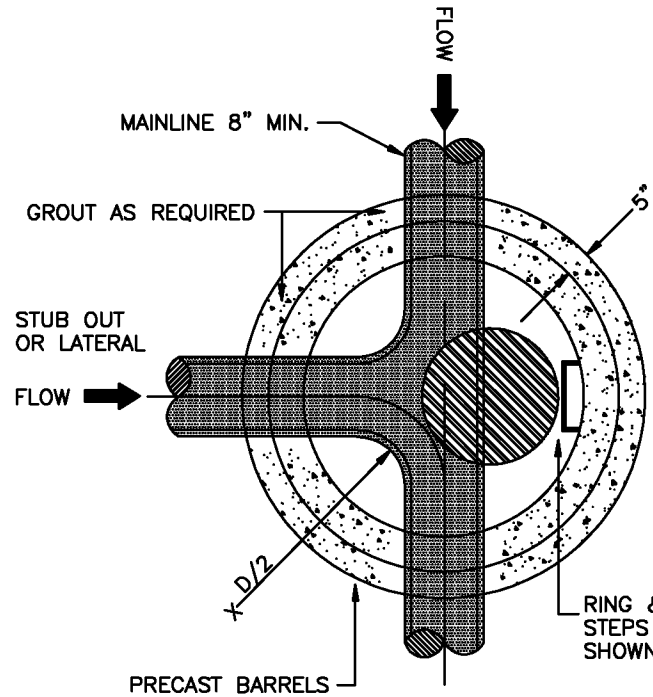

DESIGNED BY:	NTUA
SURVEYED BY:	
DRAWN BY:	NTUA
APPROVED BY:	NTUA
DATE:	3/08
PROJECT NO.:	
SCALE:	NTS
ACAD FILENAME:	Waterwaste Standard
DWG. NO.:	WWS-2

**NAVAJO TRIBAL UTILITY AUTHORITY**  
of the Navajo Nation  
**SHALLOW PRECAST MANHOLE DETAIL**  
EQ-ENGINEERING FT. DEFENCE, AZ

REVISIONS			
No.	Date	Brief	By
01	3/08	Revised	L.H.
02			
03			
04			
05			
06			



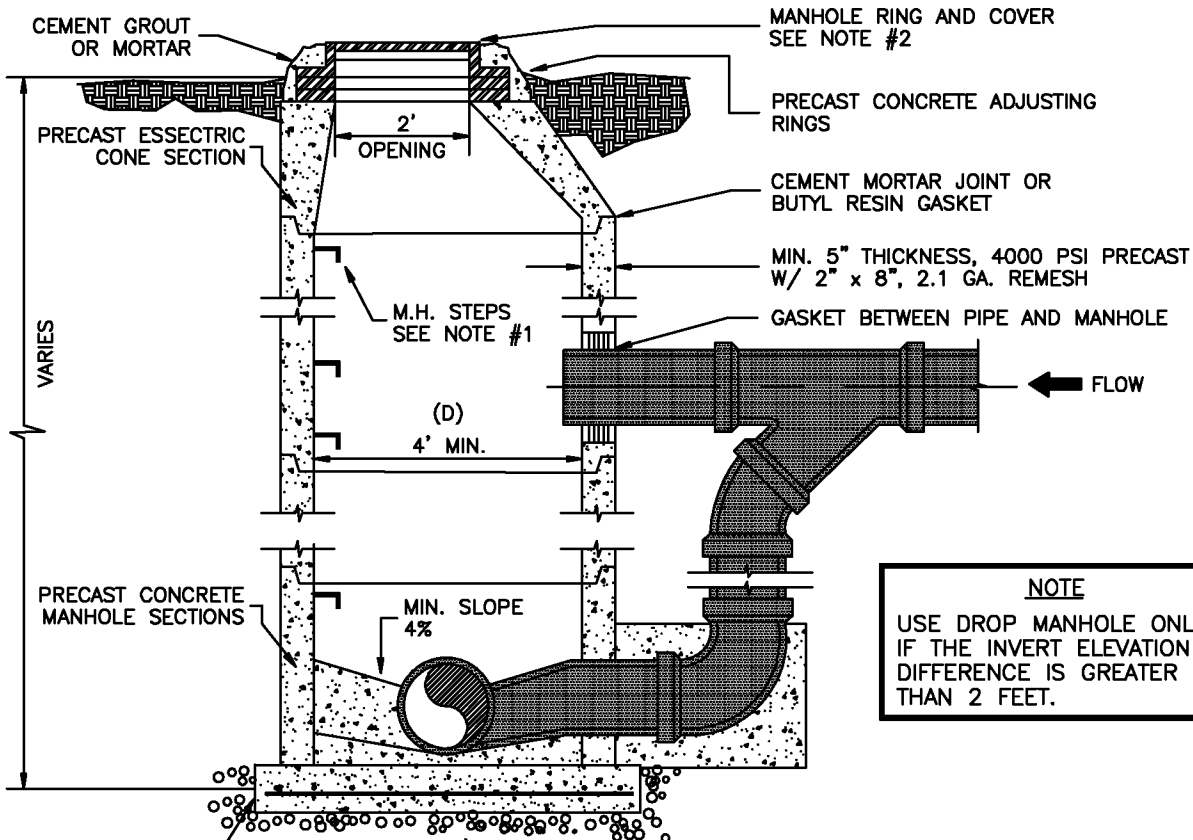

**NOTE**  
 USE DROP MANHOLE ONLY  
 IF THE INVERT ELEVATION  
 DIFFERENCE IS GREATER  
 THAN 2 FEET.

**MANHOLE BASE:**  
 6" MIN. COMPACTED GRAVEL BASE

FOR MANHOLES 6-15'  
 DEEP, #4-12" O.C.E.W.,  
 W/ 6" THICK BASE.

FOR MANHOLES 15'+  
 DEEP, #4-6" O.C.E.W.,  
 W/ 8" THICK BASE.

**NOTES:**

1. SEE STANDARD DRAWINGS OF MANHOLE STEPS, WWS-8
2. SEE STANDARD DRAWINGS OF MANHOLE RING AND COVER, WWS-7.
3. ALL CONCRETE CHANNELS SHALL BE A MIN. OF 3000 PSI RICH-MIX.
4. GROUT ALL LIFTING HOLES.
5. INVERT ELEV., OUTLET ELEV., RIM ELEV., & DROP ELEV. SHOULD BE THE SAME SIZE AS SHOWN ON CONSTRUCTION DRAWINGS.
6. ALL STRUCTURAL CONCRETE SHALL BE 4000 PSI.

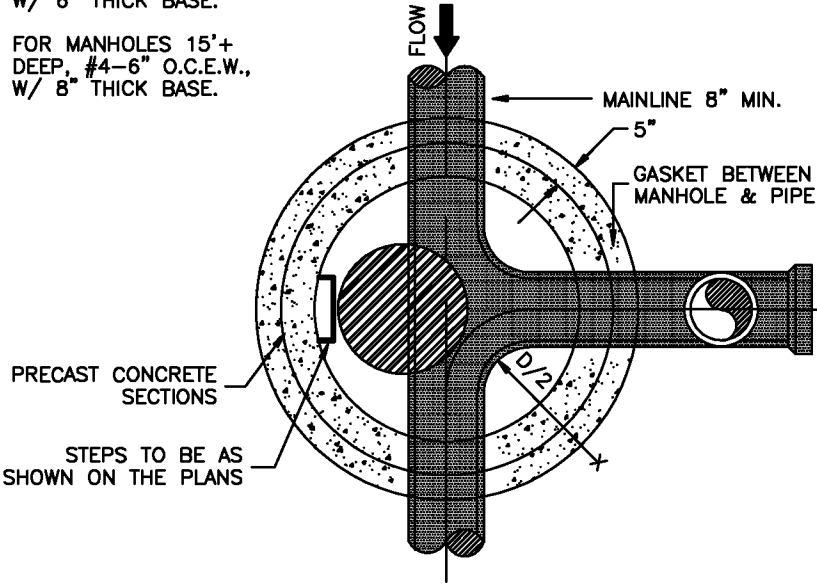

DESIGNED BY:	NTUA
SURVEYED BY:	
DRAWN BY:	NTUA
APPROVED BY:	NTUA
DATE:	3/08
PROJECT NO.	
SCALE:	NTS
ACAD FILENAME:	Waterwaste Standard
DWG. NO.	WWS-3

NAVAJO TRIBAL UTILITY AUTHORITY  
of the Navajo Nation

**DROPPED MANHOLE  
 DETAIL**

EQ-ENGINEERING      FT. DEFENCE, AZ

REVISIONS			
No.	Date	Brief	By
01	3/08	Revised	L.H.
02			
03			
04			
05			
06			





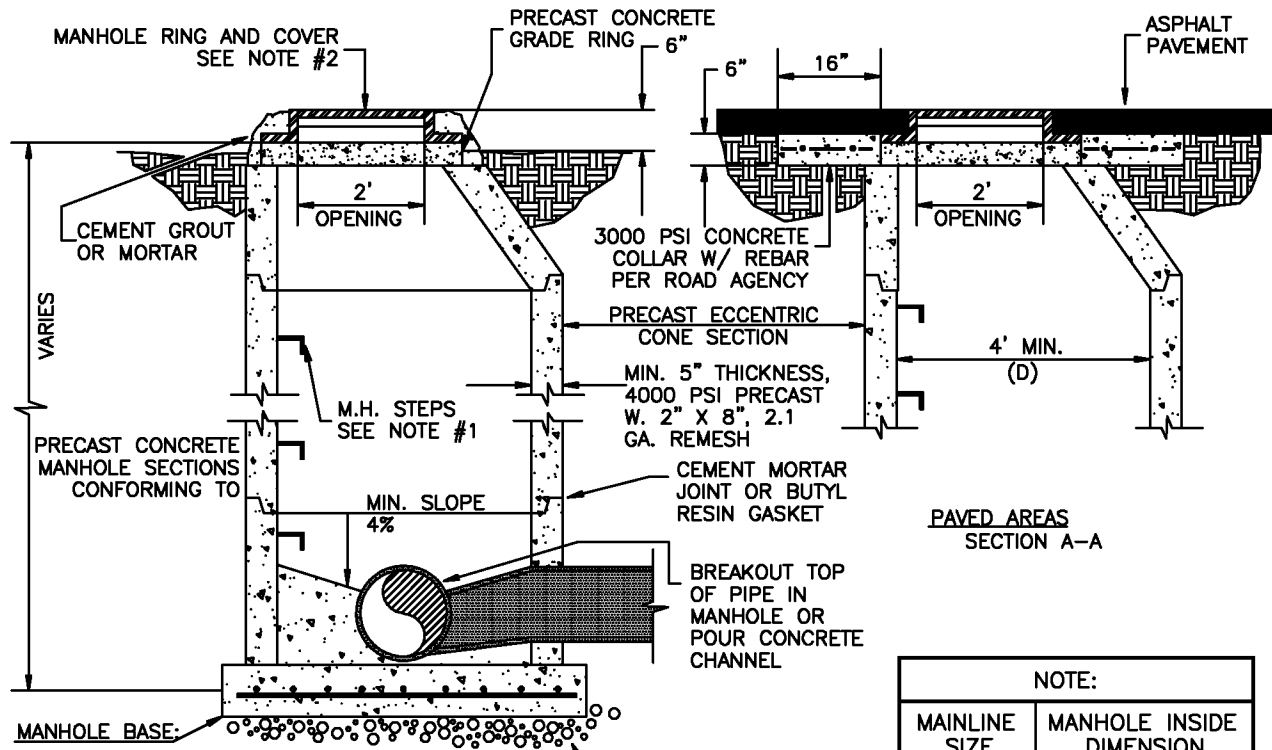

FOR MANHOLES 6-15'  
DEEP, #4-12" O.C.E.W.,  
W/ 6" THICK BASE.

FOR MANHOLES 15'+  
DEEP, #4-6" O.C.E.W.,  
W/ 8" THICK BASE.

BACKFILL SHALL BE  
COMPACTED TO 90%  
STANDARD PROCTOR  
6" MIN. COMPACTED  
GRAVEL BASE

NOTE:	
MAINLINE SIZE	MANHOLE INSIDE DIMENSION
8" TO 24"	4'-0"
OVER 24"	6'-0"

RURAL UNPAVED  
AREAS  
SECTION A-A

**NOTES:**

1. SEE STANDARD DRAWINGS OF MANHOLE STEPS, WWS-8
2. SEE STANDARD DRAWINGS OF MANHOLE RING AND COVER, WWS-7.
3. ALL CONCRETE CHANNELS SHALL BE A MIN. OF 3000 PSI RICH-MIX.
4. GROUT ALL LIFTING HOLES.
5. INVERT ELEV., OUTLET ELEV., RIM ELEV., & DROP ELEV. SHOULD BE THE SAME AS SHOWN ON CONSTRUCTION DRAWINGS.
6. ALL STRUCTURAL CONCRETE SHALL BE 4000 PSI.

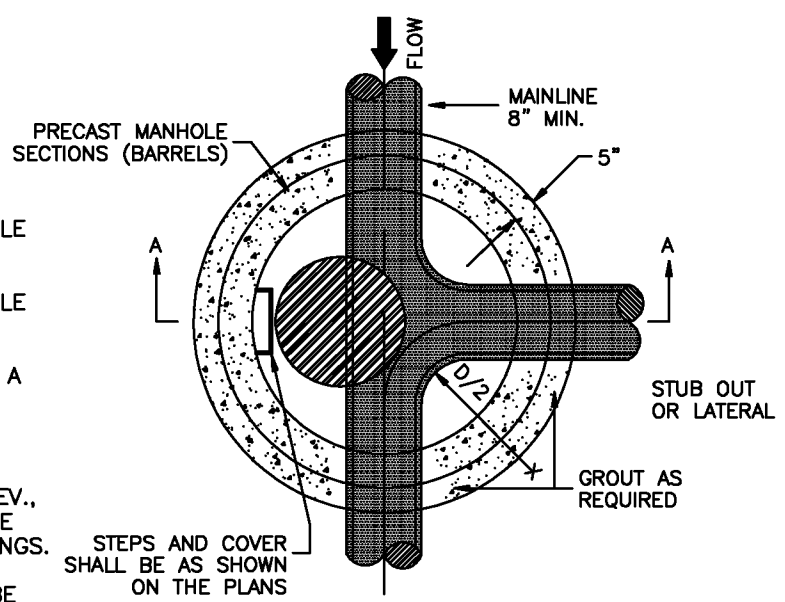

STEPS AND COVER  
SHALL BE AS SHOWN  
ON THE PLANS

DESIGNED BY:	NTUA
SURVEYED BY:	
DRAWN BY:	NTUA
APPROVED BY:	NTUA
DATE:	3/08
PROJECT NO.	
SCALE:	NTS
ACAD FILENAME:	Waterwaste Standard
DWG. NO.	WWS-4

**NAVAJO TRIBAL UTILITY AUTHORITY**  
BY THE CHIEF ENGINEER

**STANDARD PRECAST SEWER  
MANHOLE DETAIL**

EE-ENGINEERING      FT. DEFENCE, AZ

REVISIONS			
No.	Date	Brief	By
01	3/08	Revised	L.H.
02			
03			
04			
05			
06			



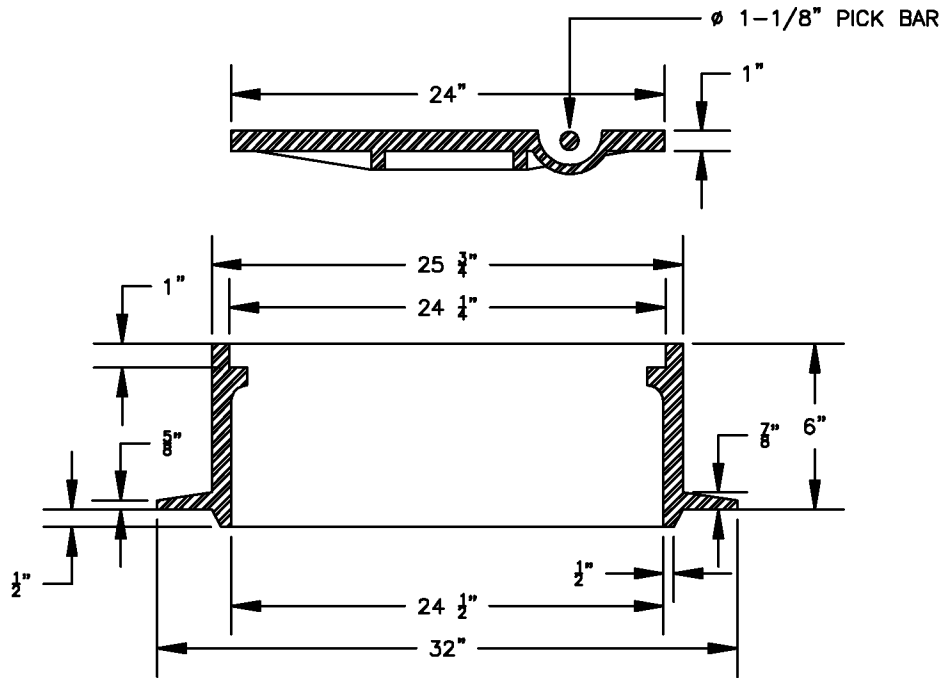
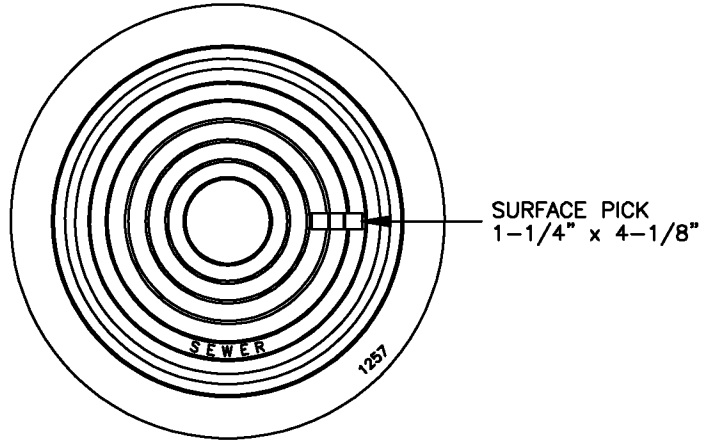

**NOTES:**

1. RING AND COVER SHALL BE CAST IRON (C.I.)  
ASTM A48-94A.
2. THE WORD "SEWER" SHALL BE CAST ON THE  
COVER.
3. C.I. MANHOLE RING AND COVER, HEAVY DUTY  
DEETER FOUNDRY, INC., MODEL #1257  
W/ 1265 COPE.
4. TOTAL WEIGHT, 330 LBS.

DESIGNED BY:	NTUA
SURVEYED BY:	
DRAWN BY:	NTUA
APPROVED BY:	NTUA
DATE:	3/08
PROJECT NO.	
SCALE:	NTS
ACAD FILENAME:	Waterwaste Standard
DWG. NO.	WWS-5

**NAVAJO TRIBAL UTILITY AUTHORITY**  
AN EQUAL OPPORTUNITY ORGANIZATION  
**STANDARD MANHOLE RING  
AND COVER**

EEQ-ENGINEERING      FT. DEFENCE, AZ

REVISIONS			
No.	Date	Brief	By
01	3/08	Revised	L.H.
02			
03			
04			
05			
06			



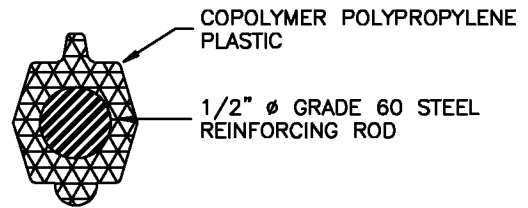
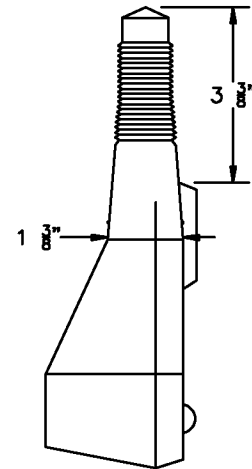
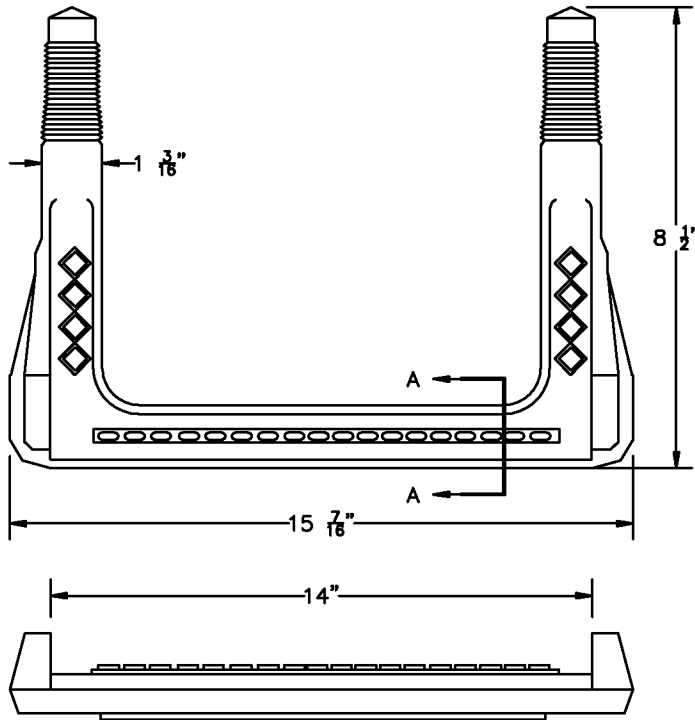

SECTION A-A

PLASTIC COATED STEP DETAIL

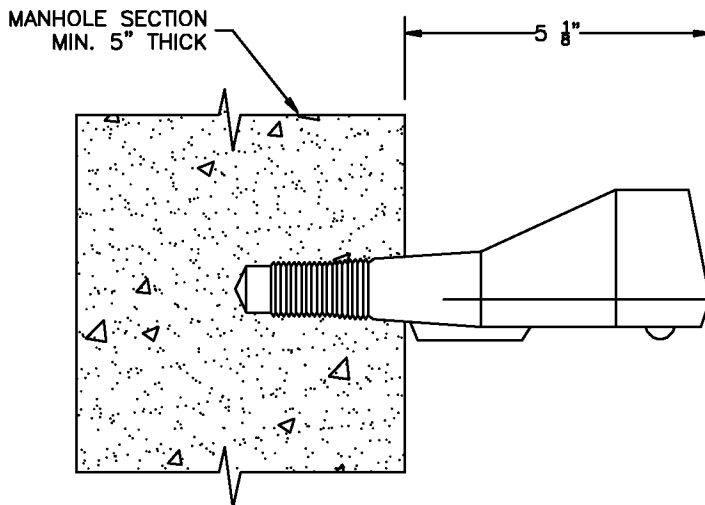

NOTES:

1. CONFORMS TO ASTM SPEC. C-478.
2. MAX. SPACING FOR STEPS ARE TO BE 16 IN. O.C., 18 IN. ABOVE CHANNEL AND 24 IN. BELOW RING AND COVER.
3. INSTALLATION SHALL BE ACCORDING TO MANUFACTURERS' INSTRUCTIONS (M.A. INDUSTRIES).
4. LOCATION OF MANHOLE STEPS SHALL BE PLACED IN ACCORDANCE WITH PLANS.

DESIGNED BY:	NTUA
SURVEYED BY:	
DRAWN BY:	NTUA
APPROVED BY:	NTUA
DATE:	3/08
PROJECT NO.:	
SCALE:	NTS
ACAD FILENAME:	Waterwaste Standard
DWG. NO.:	WWS-6

**NAVAJO TRIBAL UTILITY AUTHORITY**  
AN EQUAL OPPORTUNITY ORGANIZATION

**MANHOLE STEPS**

EQ-ENGINEERING      FT. DEFENCE, AZ

REVISIONS			
No.	Date	Brief	By
01	3/08	Revised	L.H.
02			
03			
04			
05			
06			



DESIGNED BY:	NITUA
DRAWN BY:	NITUA
APPROVED BY:	NITUA
DATE:	3/08
PROJECT NO.:	
SCALE:	NIS
QA/FIELD/INSTRUMENTATION STANDARD:	
DOC. NO.:	W/S-7

NAVAJO TRIBAL UTILITY AUTHORITY  
BY THE CHIEF ENGINEER  
**GREASE TRAP  
DETAIL**  
PLUMBING, JT

No.	Date	By
01	3/08	Reviewed
02		
03		
04		
05		
06		

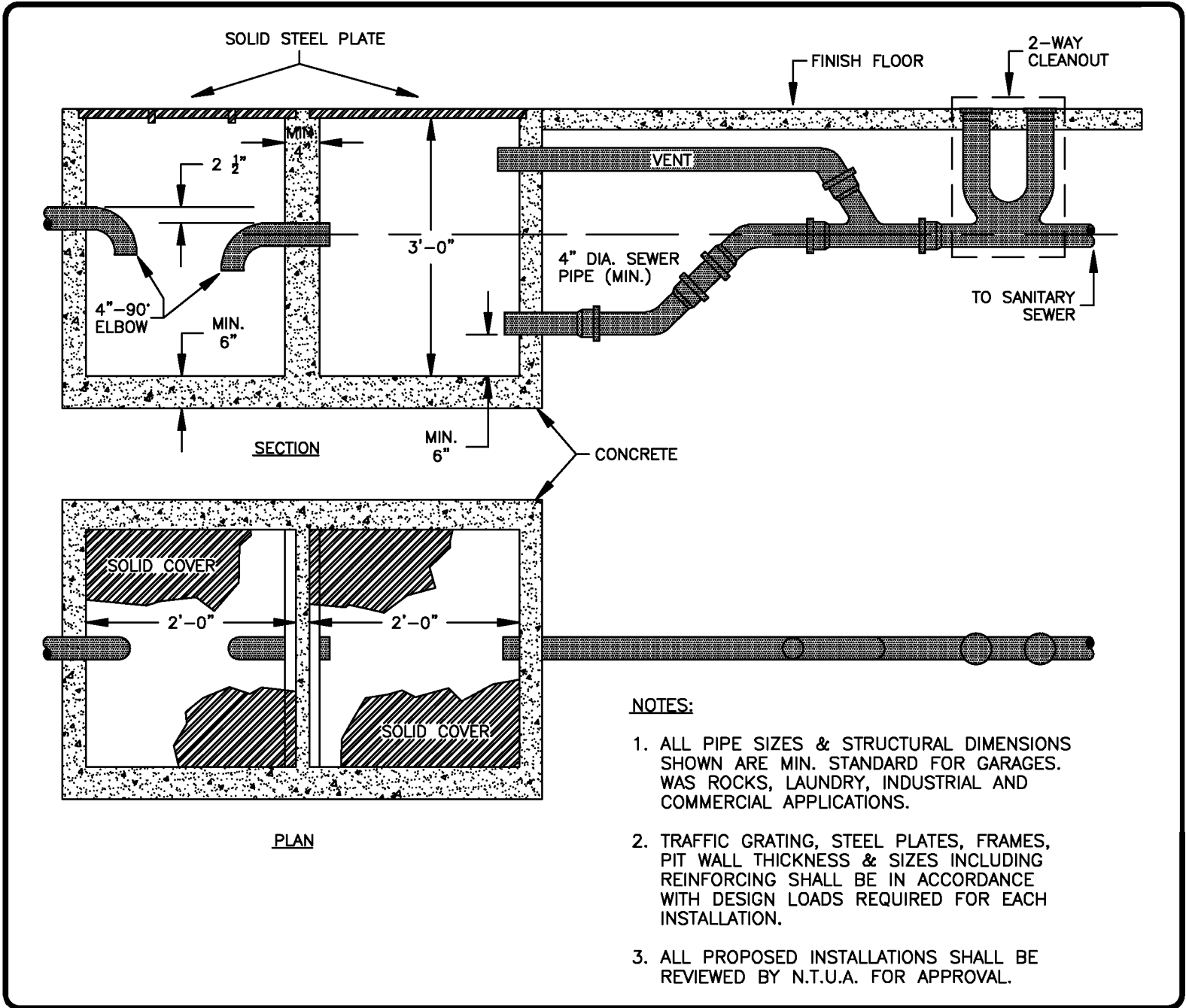

- NOTES:**
1. ALL PIPE SIZES & STRUCTURAL DIMENSIONS SHOWN ARE MIN. STANDARD FOR GARAGES. WAS ROCKS, LAUNDRY, INDUSTRIAL AND COMMERCIAL APPLICATIONS.
  2. TRAFFIC GRATING, STEEL PLATES, FRAMES, PIT WALL THICKNESS & SIZES INCLUDING REINFORCING SHALL BE IN ACCORDANCE WITH DESIGN LOADS REQUIRED FOR EACH INSTALLATION.
  3. ALL PROPOSED INSTALLATIONS SHALL BE REVIEWED BY N.T.U.A. FOR APPROVAL.

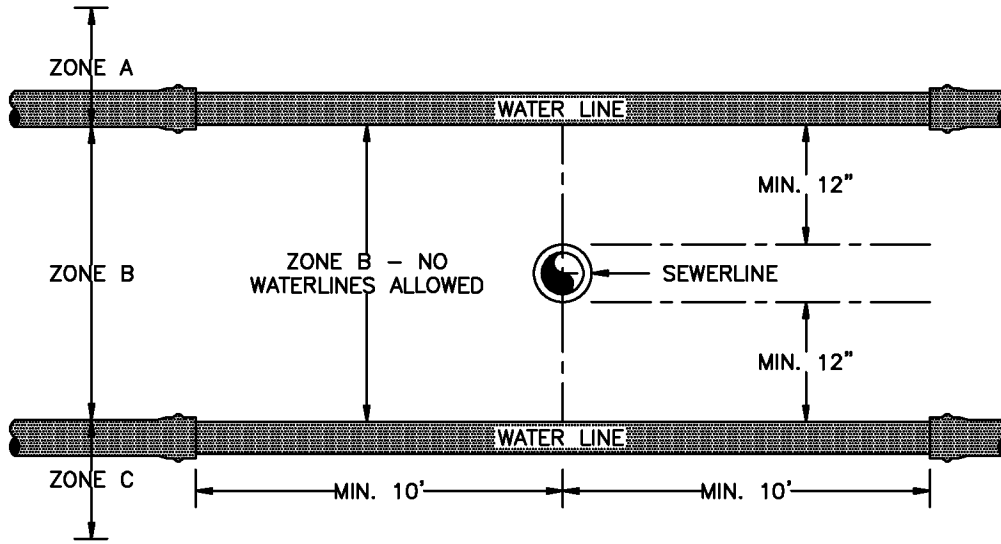

ZONE A – THE BOTTOM OF THE WATER LINE SHALL BE 12 IN. OR MORE ABOVE THE TOP OF THE SEWER LINE – NO SPECIAL PRECAUTIONS REQUIRED.

ZONE B – 12 FT. ABOVE AND 12 FT. BELOW SEWER LINE – NO WATER LINES ALLOWED.

ZONE C – THE TOP OF THE WATER LINE SHALL BE 12 IN. OR MORE BELOW THE BOTTOM OF THE SEWER LINE. IF THE SEWER LINE IS A NEWLY CONSTRUCTED SEWER LINE, AN 18 IN. LENGTH OF DUCTILE IRON SEWER PIPE W/ GASKETED JOINTS SHALL BE CENTERED OVER THE WATER LINE IN EACH DIRECTION. IF THE WATER LINE IS IN ZONE C AND THE WATER MAIN IS A NEWLY CONSTRUCTED WATER LINE, A 20 FT. LENGTH OF PVC WATER PIPE SHALL BE CENTERED UNDER THE SEWER LINE.

**NOTES:**

1. WHEN POSSIBLE, WATER LINES SHALL BE INSTALLED ABOVE SEWER LINES AND CROSSINGS SHALL BE AT 90° ANGLE(S).
2. WHEN WATER AND SEWER LINES ARE INSTALLED PARALLEL TO EACH OTHER, THE MINIMUM HORIZONTAL SEPARATION SHALL BE 10 FT.

DESIGNED BY:	NTUA
SURVEYED BY:	
DRAWN BY:	NTUA
APPROVED BY:	NTUA
DATE:	3/08
PROJECT NO.	
SCALE:	NTS
ACAD FILENAME:	Waterwaste Standard
DWG. NO.	WWS-8

**NAVAJO TRIBAL UTILITY AUTHORITY**  
IN THE STATE OF ARIZONA

**WATER AND SEWER  
CROSSING SEPERATION**

EE-ENGINEERING FT.DENVER, AZ

REVISIONS			
No.	Date	Brief	By
01	3/08	Revised	L.H.
02			
03			
04			
05			
06			



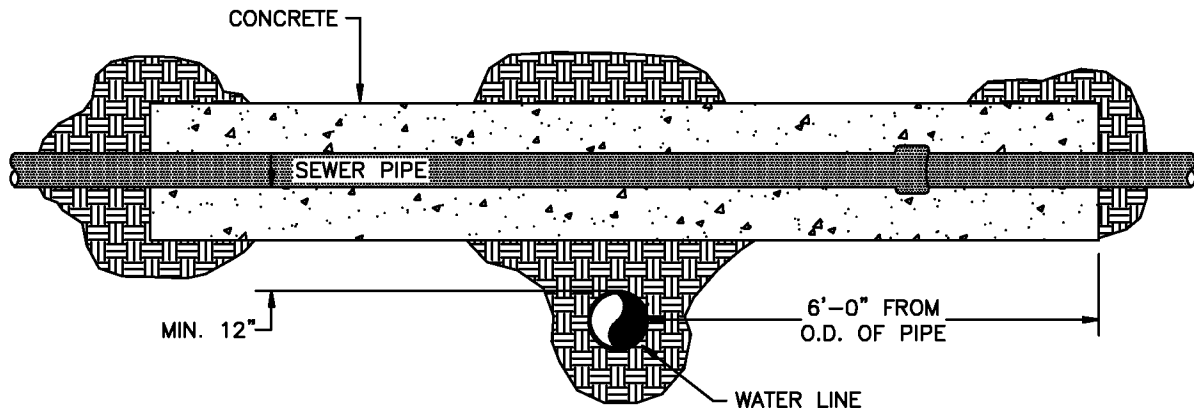

**SEWER CROSSING**

**NOTES:**

IF WATER LINE IS INSTALLED CLOSER THAN 12 IN. UNDER AN EXISTING SEWER LINE, A CONCRETE ENCASEMENT OF THE SEWER LINE IS REQUIRED, OTHERWISE, SEE NOTE BELOW.

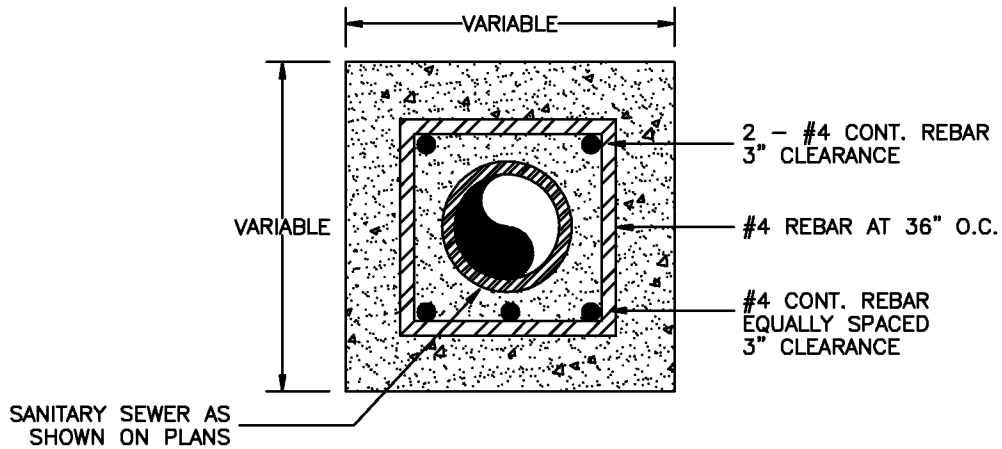

**CONCRETE ENCASEMENT DETAIL**

**NOTES:**

WHERE A WATER LINE PASSES BENEATH AN EXISTING SEWER LINE LESS THAN 12 IN., THE SEWER LINE SHALL BE ENCASED IN CONCRETE 6 IN. THICK AS DETAILED FOR NO LESS THAN 6 FT. ON EACH SIDE OF THE WATER LINE, OR THE SEWER LINE SHALL BE DUCTILE IRON PIPE WITH PRESSURE-TYPE JOINTS NO CLOSER THAN 10 FT. ON EACH SIDE OF THE WATER LINE. THIS SHALL ALSO APPLY WHERE A PARALLEL WATER LINE IS LESS THAN 10 IN. HORIZONTALLY AND LESS THAN 12 IN. ABOVE THE SEWER LINE.

DESIGNED BY:	NTUA
SURVEYED BY:	
DRAWN BY:	NTUA
APPROVED BY:	NTUA
DATE:	3/08
PROJECT NO.	
SCALE:	NTS
ACAD FILENAME:	Waterwaste Standard
DWG. NO.	WWS-9

**NAVAJO TRIBAL UTILITY AUTHORITY**  
OF THE Navajo Nation

**SEWER CROSSING &  
 CONCRETE ENCASEMENT  
 DETAIL**

EEG-ENGINEERING      FT. DEFENCE, AZ

REVISIONS			
No.	Date	Brief	By
01	3/08	Revised	L.H.
02			
03			
04			
05			
06			



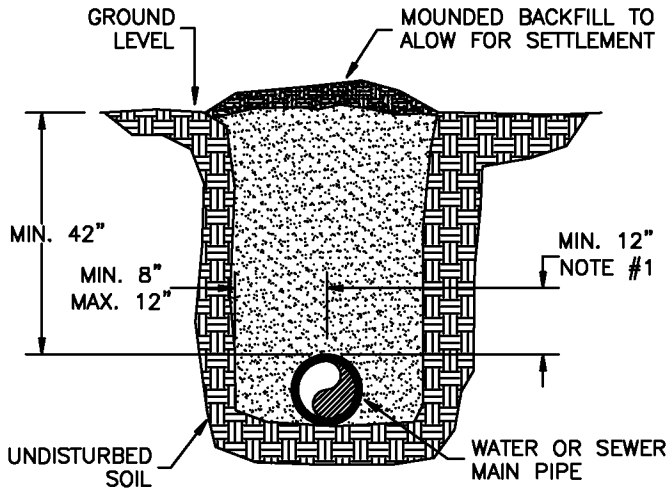

TYPICAL TRENCH DETAIL

NOTES:

1. HAND COMPACTED IN 6 IN. LIFTS FROM BOTTOM OF TRENCH TO 12 IN. ABOVE PIPE CROWN.
2. OPEN CUT OR PAVED OR GRAVEL ROADS (IF REQUIRED), BACK FILL MINIMUM COMPACTION 95% OPTIMUM DENSITY IN LIFTS.
3. REPAVING AND REGRAVELING WILL BE DONE TO ROAD OWNER'S REQUIREMENTS.
4. KEEP LOWER 5 FT. OF TRENCH WALL VERTICAL IF POSSIBLE. UPPER PART OF THE TRENCH WILL VARY IN WIDTH TO COMPENSATE FOR UNSTABLE SOIL. APPLICABLE O.S.H.A. REQUIREMENTS SHALL BE MET.

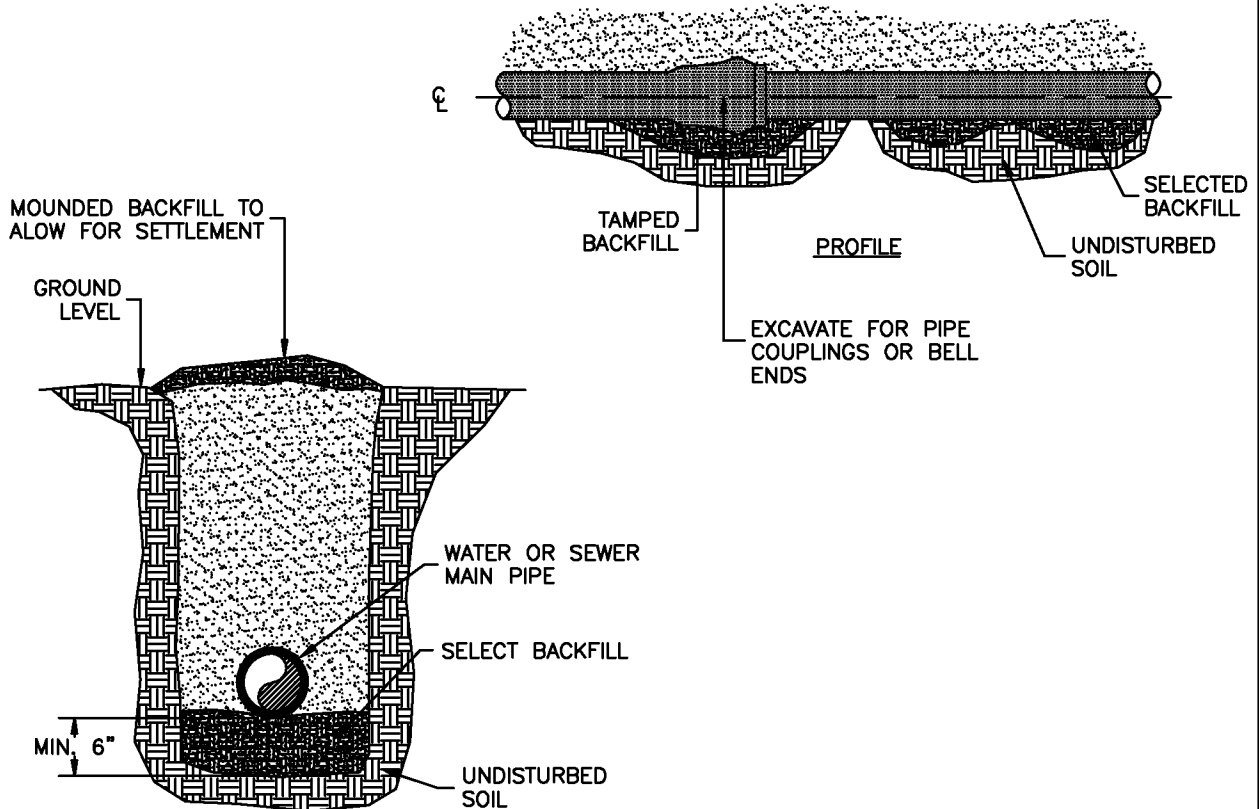

ALTERNATE TRENCH DETAIL

DESIGNED BY:	NTUA
SURVEYED BY:	
DRAWN BY:	NTUA
APPROVED BY:	NTUA
DATE:	3/08
PROJECT NO.	
SCALE:	NTS
ACAD FILENAME:	Waterwaste Standard
DWG. NO.	WWS-10

**NAVAJO TRIBAL UTILITY AUTHORITY**  
AN EQUAL OPPORTUNITY ORGANIZATION  
**STANDARD TRENCH**  
**DETAIL**

EQ-ENGINEERING
PT.DIFFANCE, AZ

REVISIONS			
No.	Date	Brief	By
01	3/08	Revised	L.H.
02			
03			
04			
05			
06			



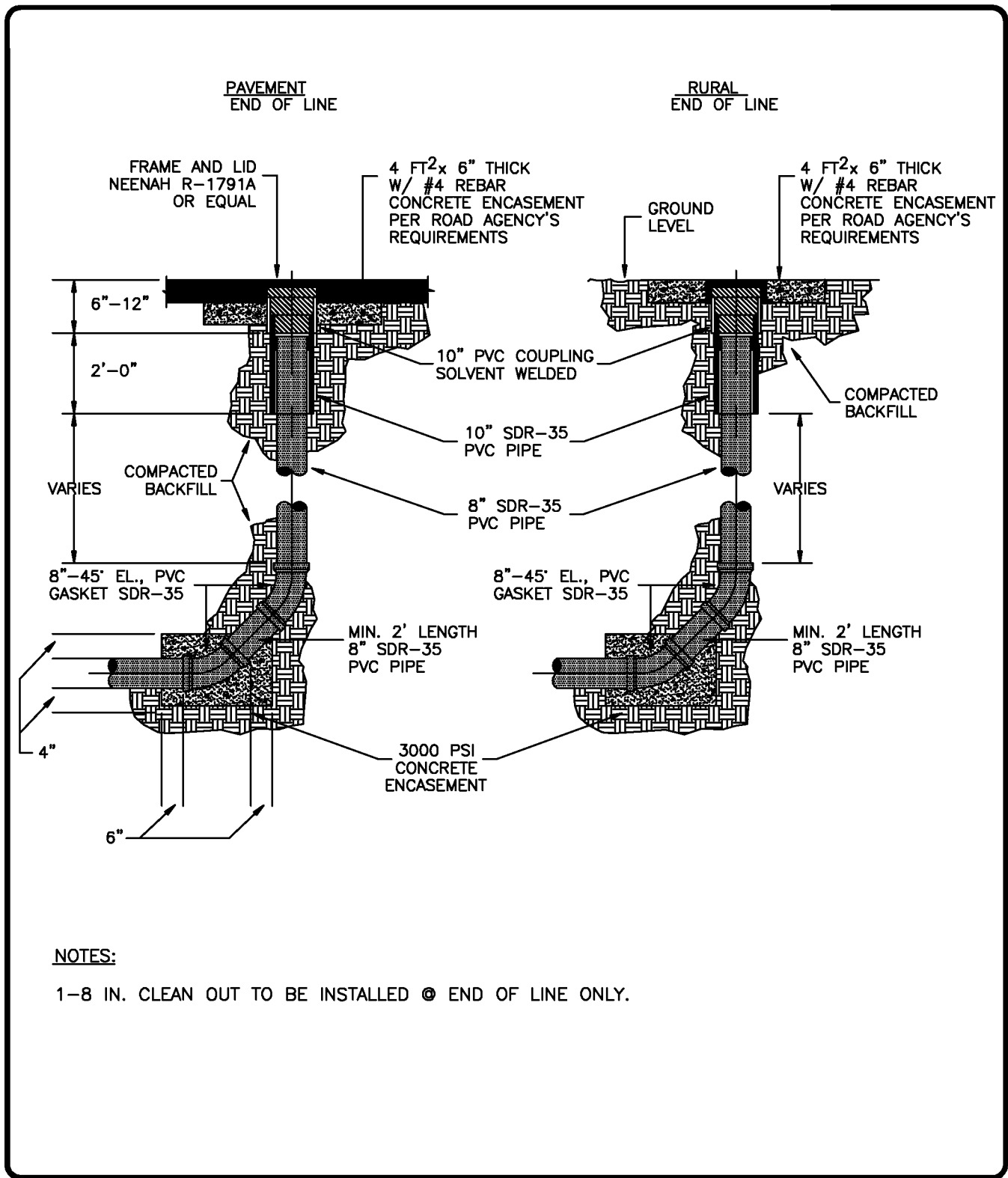

**NOTES:**

1-8 IN. CLEAN OUT TO BE INSTALLED @ END OF LINE ONLY.

DESIGNED BY:	NTUA
SURVEYED BY:	
DRAWN BY:	NTUA
APPROVED BY:	NTUA
DATE:	3/08
PROJECT NO.	
SCALE:	NTS
ACAD FILENAME:	Waterwaste Standard
DWG. NO.	WWS-11

**NAVAJO TRIBAL UTILITY AUTHORITY**  
IN THE DISTRICT OF COLUMBIA

**STANDARD 8" SEWER  
 CLEANOUT DETAIL**

EEQ-ENGINEERING      FT. DEFENCE, AZ

REVISIONS			
No.	Date	Brief	By
01	3/08	Revised	L.H.
02			
03			
04			
05			
06			





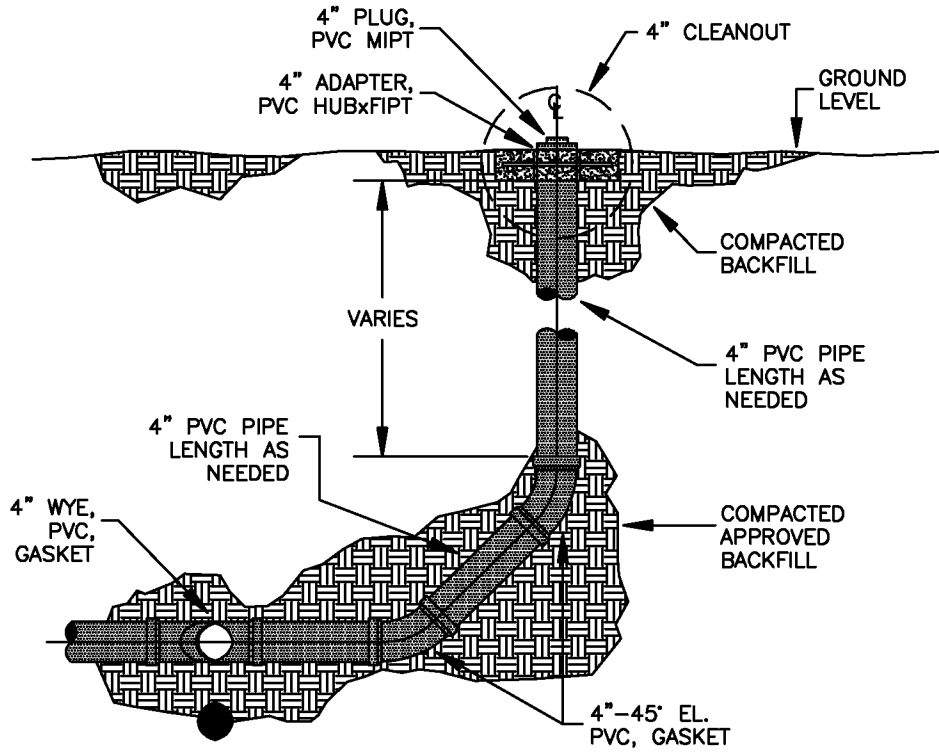

PROFILE VIEW

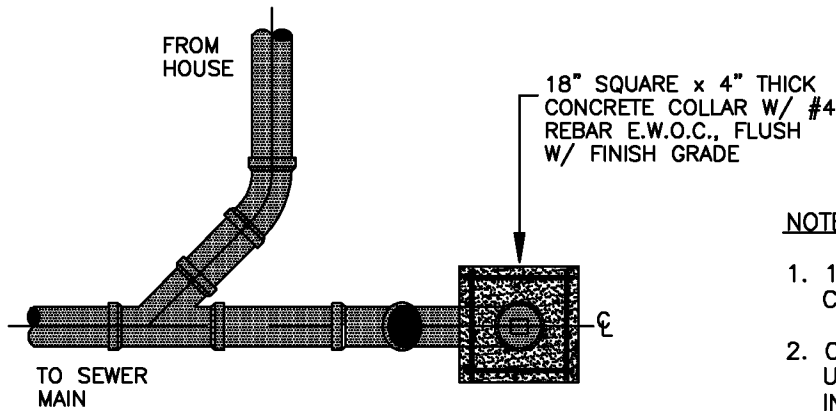

PLAN VIEW

NOTES:

1. 100 FT. MAX. BETWEEN CLEANOUTS.
2. CLEANOUT REQUIRED AT UPSTREAM OF ANY BEND IN EXCESS OF 45'.

DESIGNED BY:	NTUA
SURVEYED BY:	
DRAWN BY:	NTUA
APPROVED BY:	NTUA
DATE:	3/08
PROJECT NO.	
SCALE:	NTS
ACAD FILENAME:	Waterwaste Standard
DWG. NO.	WWS-12

**NAVAJO TRIBAL UTILITY AUTHORITY**  
AN EQUAL OPPORTUNITY ORGANIZATION  
**4" SEWER CLEANOUT DETAIL**  
EQ-ENGINEERING FT. DEFENCE, AZ

REVISIONS			
No.	Date	Brief	By
01	3/08	Revised	L.H.
02			
03			
04			
05			
06			



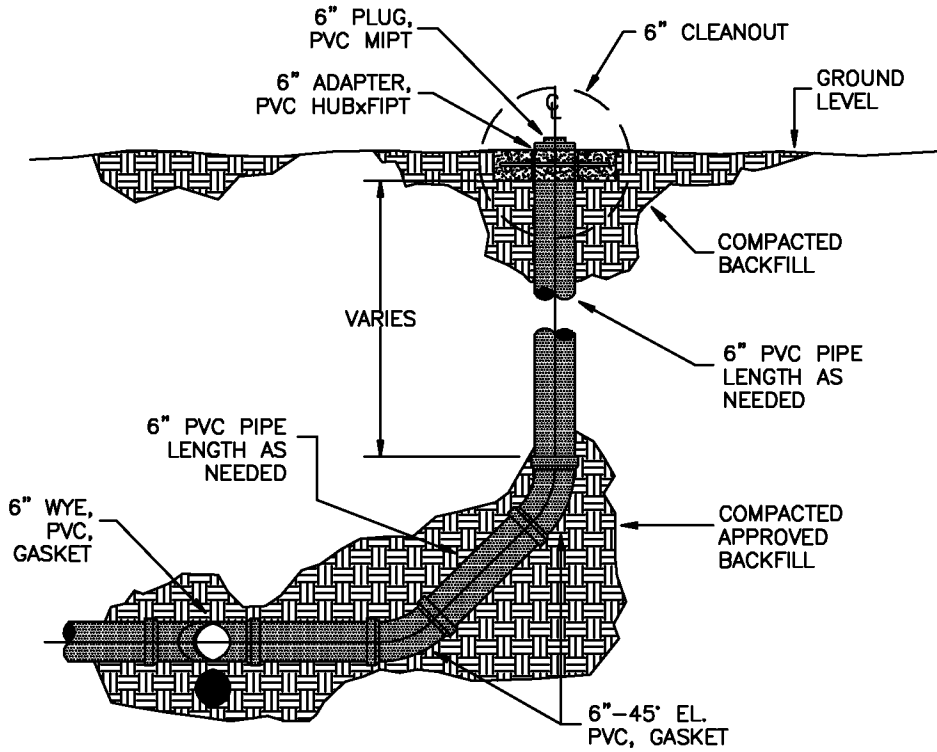

PROFILE VIEW

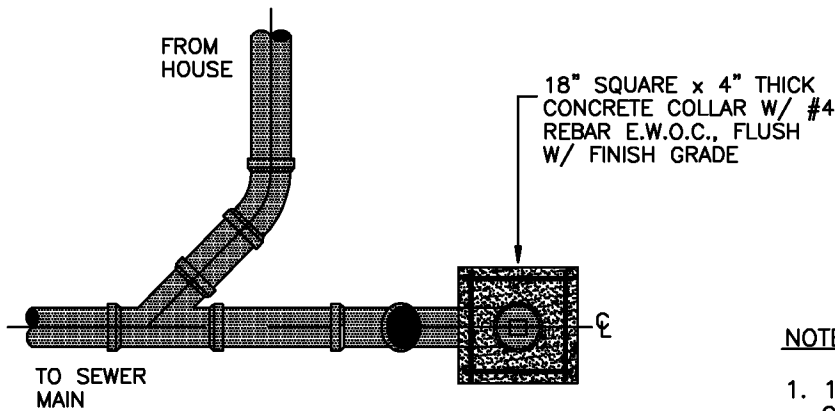

PLAN VIEW

NOTES:

1. 100 FT. MAX. BETWEEN CLEANOUTS.
2. CLEANOUT REQUIRED AT UPSTREAM OF ANY BEND IN EXCESS OF 45°.

DESIGNED BY:	NTUA
SURVEYED BY:	
DRAWN BY:	NTUA
APPROVED BY:	NTUA
DATE:	3/08
PROJECT NO.:	
SCALE:	NTS
ACAD FILENAME:	Waterwaste Standard
DWG. NO.:	WWS-13

**NAVAJO TRIBAL UTILITY AUTHORITY**  
AN EQUAL OPPORTUNITY ORGANIZATION  
**6" SEWER CLEANOUT DETAIL**  
REQ-ENGINEERING FT. DEFENCE, AZ

REVISIONS			
No.	Date	Brief	By
01	3/08	Revised	L.H.
02			
03			
04			
05			
06			



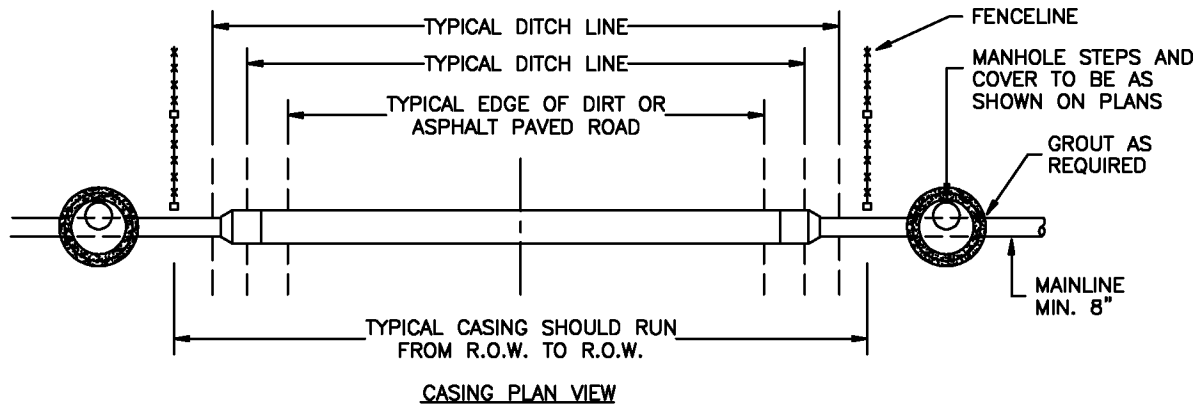

CASING PLAN VIEW

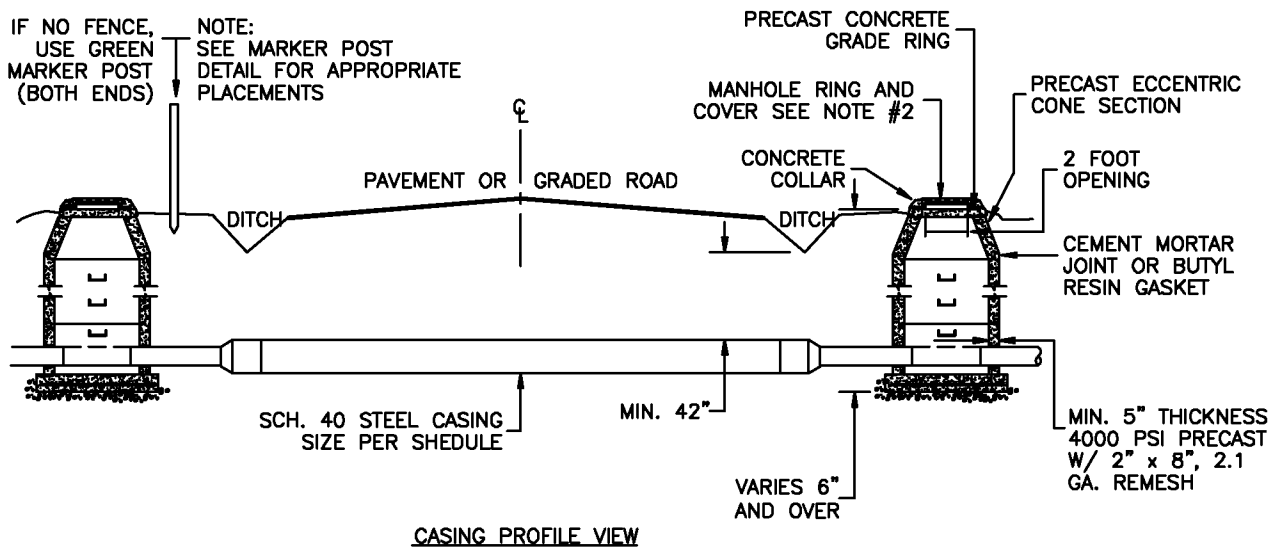

CASING PROFILE VIEW

**NOTES:**

1. SEE STANDARD DRAWING FOR MANHOLE STEPS, WWS-8.
2. SEE STANDARD DRAWING FOR MANHOLE RING AND COVER, WWS-7.
3. CONCRETE CHANNELS SHALL BE A MIN. OF 3000 PSI RICH-MIX.
4. GROUT ALL LIFTING HOLES.
5. INVERT ELEV., OUTLET ELEV., RIM ELEV., & DROP ELEV. SHALL BE SHOWN ON PLANS.
6. ALL STRUCTURAL CONCRETE SHALL BE 4000 PSI.
7. ROAD SHALL BE BORED UNDER EXISTING PAVEMENT AND OPEN TRENCH ON REMAINDER, UNLESS OTHERWISE SPECIFIED.

DESIGNED BY:	NTUA
SURVEYED BY:	
DRAWN BY:	NTUA
APPROVED BY:	NTUA
DATE:	3/08
PROJECT NO.	
SCALE:	NTS
ACAD FILENAME:	Waterwaste Standard
DWG. NO.	WWS-14

**NAVAJO TRIBAL UTILITY AUTHORITY**  
IN THE STATE OF ARIZONA

**TYPICAL ROAD CROSSING  
FOR NTUA SEWERLINES**

EEG-ENGINEERING      FT. DEFENCE, AZ

REVISIONS			
No.	Date	Brief	By
01	3/08	Revised	L.H.
02			
03			
04			
05			
06			



LEGEND

	EXISTING WATER MAIN W/ LINE SIZE, TYPE, & PSI RATING INDICATED
	PROPOSED WATERLINE W/ SIZE TYPE, & PSI RATING INDICATED
	EXISTING SEWER MAIN W/ SIZE, TYPE, & LENGTH INDICATED
	PROPOSED SEWER MAIN W/ SIZE, TYPE, & LENGTH INDICATED
	HOUSE W/ CUSTOMER NAME AND/OR HOUSE NUMBER
	SEPTIC TANK
	FENCELINE
	PAVED OR GRADED ROAD
	UNIMPROVED ROAD
	ARCHAEOLOGICAL SITE
	WASH OR ARROYO
	PRESSURE REDUCING VALVE (VAULT)
	AIR RELEASE VALVE
	DOMESTIC STOP
	FIRE HYDRANT W/ GATE VALVE
	CLEANOUT
	GATE VALVE
	CURB STOP
	METER
	PROPOSED SEWERLINE & MANHOLE W/ FLOW DIRECTION
	EXISTING SEWER LINE & MANHOLE W/ FLOW DIRECTION
	REDUCER
	OVERHEAD ELECTRIC LABEL WITH JNC-TEP FOR TELEPHONE JNC-CATV FOR CABLE TV (JNC IS JOINT NAVAJO COMMUNICATION)
	UNDERGROUND ELECTRIC
	LINE CROSSING
	METER W/ INDIVIDUAL PRV
	FLUSH VALVE
	GAS LINE
	MARKER POST
	YARD HYDRANT
	INFILTRATORS

DESIGNED BY:	NTUA
SURVEYED BY:	
DRAWN BY:	NTUA
APPROVED BY:	NTUA
DATE:	3/08
PROJECT NO.:	
SCALE:	NTS
ACAD FILENAME:	Waterwaste Standard
DWG. NO.:	WWS-15

**NAVAJO TRIBAL UTILITY AUTHORITY**  
AN EQUAL OPPORTUNITY ORGANIZATION  
**STANDARD  
LEGEND**

EEG-ENGINEERING
PT.DENAFANCE, AZ

REVISIONS			
No.	Date	Brief	By
01	3/08	Revised	L.H.
02			
03			
04			
05			
06			



# Navajo Tribal Utility Authority



## Welding Procedures

## US 491 Road Widening Project

# NAVAJO TRIBAL UTILITY AUTHORITY

Procedure Specification No. N01B-S

API 1104, 20<sup>th</sup> Edition

Supporting Welding Procedure No. N01B-P

For Butt Welding of Steel Pipe and Fittings

Process: Shielded Metal Arc Welding (SMAW) Manual

Material: API, 5L, Grade B through X42 and Grades Y35 through Y42.

Diameter and wall thickness: 2 3/8" through 24" .154" through .750" WT

Joint design: Single "V" Bevel

Filler Metal and no. of beads: AWS A5.1: E6010, 5P+, / AWS, A5.5: E7010-P1, 3 Beads minimum or as need to complete balance of weld. Two beads shall not be started at the same location. Feather starts and stops on root pass.

Electrical or flame characteristics: Direct Current, Reverse Polarity

Position: All (Fixed)

Direction of welding: Downhill, without excessive weaving of the electrode

No. of welders: One or more as required. Two welders on pipe 12" and greater for weld passes 1 & 2.

Maximum time lapse between passes: 15 minutes between the first and second pass

: 18 hours between passes balance of weld

Type and removal of lineup clamp: None required or External clamp - 50% of pipe wall welded or

Internal clamp - 100% of pipe wall welded

Cleaning and/or grinding: Power grind root pass, Power brush and/or grind balance of weld

Preheat stress relief: 50' F minimum, 200' F minimum +150' F maximum when ambient temperature is below 50' F or when repairing or completing unfinished welds. 250' F minimum +150' F maximum when the thickness is .500" or greater. When joints of unequal thickness are welded the higher preheat shall be used. Preheat may be required to remove moisture from pipe. Maximum interpass temperature 650'F. Preheat bottom center to top of weld.

Preheat maintenance: Torch, heat in a wide area at least 2 to 4 inches on both sides of weld joint. Monitor with temperature sticks, pyrometer, digital thermometer or other suitable methods.

Alignment: Pipe of the same nominal wall thickness, offset shall not exceed 1/8"

Joints of unequal thickness: Tapered transition having a length not less than three times the offset shall be provided at joints between sections that differ in thickness by more than 3/32" of the thickness of the thinner section. The transition may be formed by any process that will provide a uniform taper.

### Sketches and tabulations:

STANDARD SINGLE "V" BEVEL BUTT JOINT

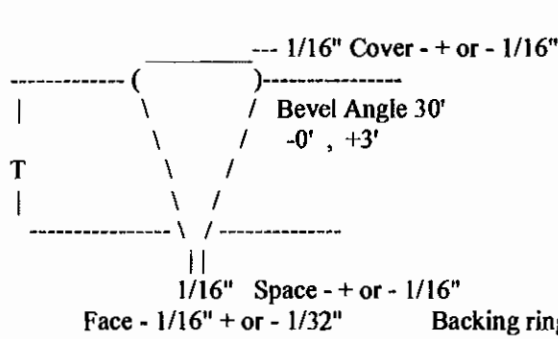

TAPERED TRANSITION

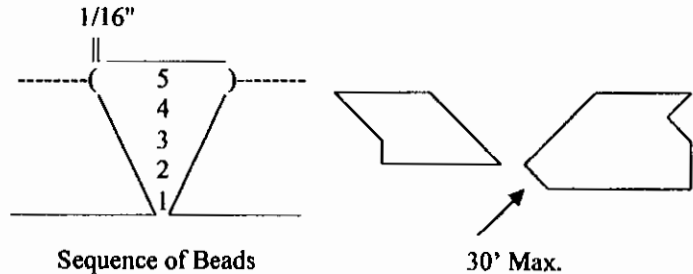

### ELECTRODE SIZE AND NUMBER OF BEADS (3 Beads Minimum)

Beads	Filler metal	Voltage	Amperage	Speed
Root pass	E6010, 5P+, 3/32"	18 - 30	40 - 80	8"/Minute Maximum
Root Pass	E6010, 5P+, 1/8"	20 - 32	75 - 130	10"/Minute Maximum
Root Pass	E6010, 5P+, 5/32"	20 - 32	90 - 175	10"/Minute Maximum
Hot Pass	E7010-P1, 1/8"	20 - 32	75 - 130	3" to 12" / Minute
Hot Pass	E7010-P1, 5/32"	20 - 32	90 - 175	3" to 12" / Minute
Fillers	E7010-P1, 1/8"	20 - 32	75 - 130	3" to 12" / Minute
Fillers	E7010-P1, 5/32"	20 - 32	90 - 175	3" to 12" / Minute
Fillers	E7010-P1, 3/16"	20 - 32	120 - 225	3" to 12" / Minute
Cover Pass	E7010-P1, 1/8"	20 - 32	75 - 130	3" to 12" / Minute
Cover Pass	E7010-P1, 5/32"	20 - 32	90 - 175	3" to 12" / Minute
Cover Pass	E7010-P1, 3/16"	20 - 32	120 - 225	3" to 12" / Minute

Tested by George C Noland 12/04/2013  
 Approved \_\_\_\_\_  
 Adopted \_\_\_\_\_

Welder Melvin Benally  
 Welding supervisor \_\_\_\_\_  
 Chief engineer \_\_\_\_\_

# NAVAJO TRIBAL UTILITY AUTHORITY

Procedure Specification No. N01F-S

API 1104, 20<sup>th</sup> Edition

Supporting Welding Procedure No. N01F-P

For Fillet Welding of Steel Pipe and Fittings

Process: Shielded Metal Arc Welding (SMAW) Manual

Material: API, 5L, Grade B through X42 and Grades Y35 through Y42.

Diameter and wall thickness: 2 3/8" through 24" .154" through .750" WT

Joint design: Fillet (See Sketches)

Filler Metal and no. of beads: AWS A5.1: E6010 5P+, / AWS, A5.5: E7010-P1, 3 Beads minimum or as need to complete balance of weld. Two beads shall not be started at the same location.

Electrical or flame characteristics: Direct Current, Reverse Polarity

Position: All (Fixed)

Direction of welding: Downhill, without excessive weaving of the electrode

No. of welders: One or more as required. Two welders on pipe 12" and greater

Maximum time lapse between passes: First pass shall be completed without interruption except to change electrodes. Between the first and second pass as soon as possible not to exceed 10 minutes. 15 minutes between passes balance of weld.

Type and removal of lineup clamp: None required or External clamp - 50% of pipe wall welded or Internal clamp - 100% of pipe wall welded

Cleaning and/or grinding: Clean 1" around the outside of weld area. Power grind root pass. Power brush and/or grind balance of weld

Preheat stress relief: 50' F minimum, 200' F minimum, +150' F maximum when ambient temperature is below 50' F or when repairing or completing unfinished welds. 250' F minimum, +150' F maximum when the thickness is .500" or greater. When joints of unequal thickness are welded the higher preheat shall be used. Preheat may be required to remove moisture from pipe. Maximum Interpass Temperature 650' F.

Preheat maintenance: Torch, heat in a wide area at least 2 to 4 inches on both sides of weld joint. Monitor with temperature sticks, pyrometer, digital thermometer or other suitable methods

Speed of travel: 2 to 10" per minute

Sketches and tabulations:

JOINT: Fillet Size  $1.4T$  Max. (T= thinner WT)

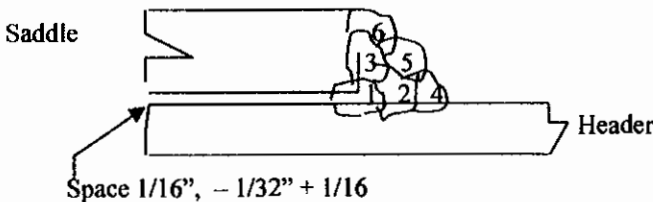

Example Temper Bead Sequence

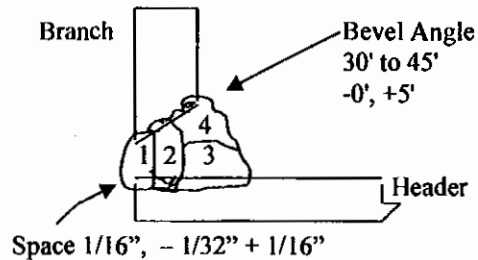

### ELECTRODE SIZE AND NUMBER OF BEADS (3 Beads Minimum)

Beads	Filler metal	Voltage	Amperage	Speed
Root pass	E6010 5P+ 3/32"	18 - 30	40 - 70	8"/Minute Maximum
Root Pass	E6010 5P+ 1/8"	20 - 32	75 - 130	10"/Minute Maximum
Root Pass	E6010 5P+ 5/32"	20 - 32	90 - 175	10"/Minute Maximum
Hot Pass	E7010-P1 1/8"	20 - 32	75 - 130	2" to 10" / Minute
Hot Pass	E7010-P1 5/32"	20 - 32	90 - 175	2" to 10" / Minute
Fillers	E7010-P1 1/8"	20 - 32	75 - 130	2" to 10" / Minute
Fillers	E7010-P1 5/32"	20 - 32	90 - 175	2" to 10" / Minute
Fillers	E7010-P1 3/16"	20 - 32	140 - 225	2" to 10" / Minute
Cover Pass	E7010-P1 1/8"	20 - 32	75 - 130	2" to 10" / Minute
Cover Pass	E7010-P1 5/32"	20 - 32	90 - 175	2" to 10" / Minute
Cover Pass	E7010-P1 3/16"	20 - 32	140 - 225	2" to 10" / Minute

Tested by George C Noland 12/05/2013

Approved \_\_\_\_\_

Adopted \_\_\_\_\_

Welder Melvin Benally

Welding supervisor \_\_\_\_\_

Chief engineer \_\_\_\_\_

**Nol-X NDT Service**  
Farmington, New Mexico

**COUPON TEST REPORT**  
PROCEDURE QUALIFICATION

<b>Code Specification</b> <u>API 1104, 20th</u>	<b>Procedure No.</b> <u>N01B-P / N01F-P</u>
<b>Facility (Name &amp; Address)</b> <u>Navajo Tribal Utility Authority</u> <u>FT. Defiance, Arizona 86504-1520</u>	<b>Welders Name.</b> <u>Melvin Benally</u> <u>***-**-1328</u>
<u>N/A</u> Single Qualification <u>YES</u> Multiple Qualification <u>Yes</u> Qualified <u>N/A</u> Disqualified Weld X-rayed <u>X</u> Yes <u>N/A</u> No	<b>Stencil No.</b> <u>MB</u> <b>Procedure Qualification</b> <u>Yes</u> <b>Welder Qualification</b> <u>Yes</u> <b>X-ray Qualification</b> <u>No</u>
<b>Pipe Manufacture &amp; Type:</b> <u>United States Steel</u> <u>API 5L, B/X42, 42,000 Minimum Yield</u>	<b>Number of Welders</b> <u>One</u> <b>Position</b> <u>5G / Branch Vertical Down</u> <b>Fixed</b> <u>Yes</u> <u>Rollled</u> <u>N/A</u> <b>Direction of Welding</b> <u>Downhill</u> <b>Time between Passes</b> <u>See Back</u>
<b>Process -</b> <u>Yes</u> <u>Manual (SMAW)</u> <u>N/A</u> <u>Semi-Automatic</u> <u>N/A</u> <u>Automatic</u>	<b>Line-up Clamps</b> <u>Internal</u> <u>External</u> <u>None Req. X</u>
<b>Material -</b> <u>X42, HT- C46068</u> <b>Minimum Tensile-</b> <u>60,000 PSI</u> <b>Dia. &amp; Wall Thickness:</b> <u>8 5/8", .322"</u> <b>Joint Design:</b> <u>Single "V" Bevel / Branch Connection</u> <b>Filler Metal &amp; No. of beads:</b> <u>Lincoln (See Back)</u> <b>Speed of Travel:</b> <u>See Back</u> <b>Ambient Temperature:</b> <u>45' F - 60'F</u>	<b>Removal of line up clamps</b> <u>N/A</u> <b>Cleaning:</b> <u>Yes</u> <u>Power tools</u> <u>Yes</u> <u>Hand Tools</u> <b>Preheat</b> <u>50' F Minimum</u> <u>Post heat N/A</u>

SINGLE "V" BUTT JOINT				TYPE OF WELD TEST		Date	Procedure No.
Stencil	Width	Wall	Area	TENSILE (PSI)		FRACTURE	Strap
	Inches	Thickness	Inches	Max. Load	Ultimate	AREA	Number
MB	1.096	.330"	.362	30,000	82,873	Base Metal	01
MB	1.055	.322"	.340	28,000	82,353	Base Metal	05
<b>Maximum Tensile 82,873</b>				<b>Minimum Tensile 82,353</b>		<b>Average Tensile 82,613</b>	
Stencil	Width	W.T.	Type of Test			Remarks	Strap
	Inches	Thickness	Face	Root			Number
MB	1.0	.322	N/A	Accepted	No Indications		03
MB	1.0	.322	N/A	Accepted	No Indications		07
MB	1.0	.322	Accepted	N/A	No Indications		04
MB	1.0	.322	Accepted	N/A	No Indications		08
NICKBREAK							
Stencil	Width	W.T.	Remarks				Strap
	Inches	Inches					Number
MB	1.0	.322	Accepted, No Indications				02
MB	1.0	.322	Accepted, No Indications				06
NICKBREAK (BRANCH CONNECTION)							
Stencil	Width	Branch WT	Header WT	Remarks			Strap
	Inches	Inches	Inches				Number
MB	1.0	.322	.322	Accepted, No Indications			01
MB	1.0	.322	.322	Accepted, No Indications			02
MB	1.0	.322	.322	Accepted, No Indications			03
MB	1.0	.322	.322	Accepted, No Indications			04

Tested By George C Noland Company Representative Jason Corral

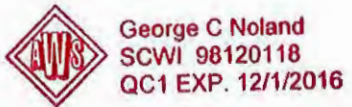



**STANDARD SINGLE "V" BEVEL BUTT JOINT**

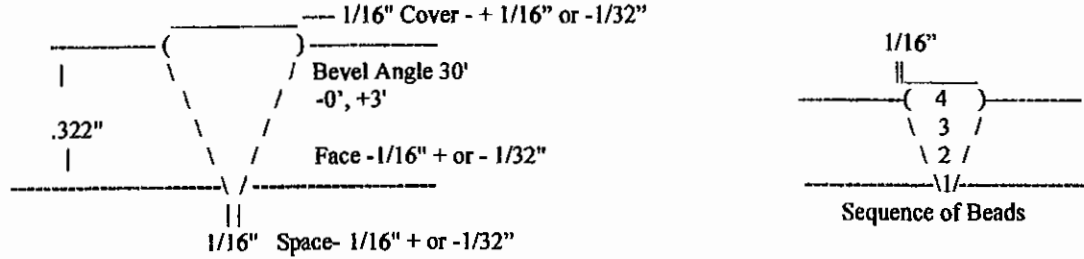

Backing rings: N/A

Beads	Filler Metal	SP+	1/8"	Voltage	Amperage	Speed	Interpass Temperature
1 Root	E6010	SP+	1/8"	24 - 26	95 - 105	5 - 6" per minute	80°F
2 Hot Pass	E7010-P1	Hyp+	5/32"	24 - 28	115 - 125	6 - 7" per minute	300°F
3 Fillers	E7010-P1	Hyp+	5/32"	24 - 28	115 - 125	5 - 7" per minute	425°F
4 Cover	E7010-P1	Hyp+	5/32"	26 - 30	105 - 115	5 - 6" per minute	550°F

**Procedure**

Qualification Thickness Limits - .154" thru .750"

Position Limitations - Fixed

Pipe Diameter Limits - None

Time Between Passes: 10 Minutes Root / Hot Pass

Filler Passes 10 Minutes

Cover passes 10 - 15 Minutes

Number of Beads: Three beads minimum

Remarks:

Visual Inspection of Welds: Accepted

Welding Machine Type: Lincoln Air Vantage 500

Type of Current & Polarity: DC, Reverse

Root Pass - Power Grind

Between Passes - Power grind or brush

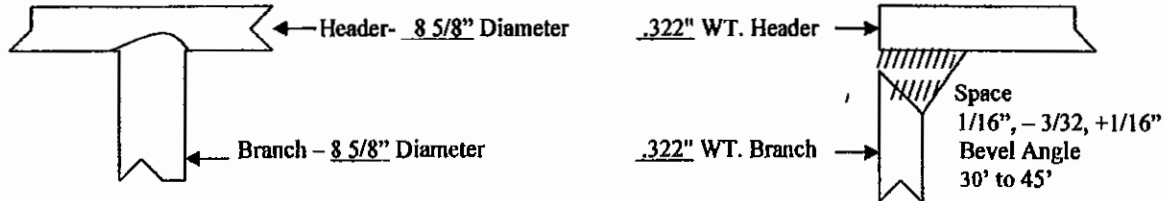

Beads	Filler Metal	SP+	1/8"	Voltage	Amperage	Speed	Interpass Temperature
1 Root	E6010	SP+	1/8"	24 - 26	90 - 110	3 - 4" per minute	95°F
2 Hot Pass	E7010-P1	Hyp+	5/32"	24 - 28	115 - 125	5 - 6" per minute	550°F
3 Fillers	E7010-P1	Hyp+	5/32"	26 - 28	105 - 120	4 - 5" per minute	620°F
4-5 Cover	E7010-P1	Hyp+	5/32"	26 - 28	125 - 135	5 - 6" per minute	520°F



UNITED STATES STEEL

TUBULAR PRODUCTS  
CERTIFIED TEST REPORT  
IN ACCORDANCE WITH ISO 10476 EN 10240 UNS 31 Type 3.1

DATE: 06/07/13  
TIME: 13:57:55  
SERIAL NO: F0074434

MATERIAL NO. DRO4462 08		SHEET NO. 132767		P.O. NUMBER 87N0429370		SHEET NO. 80KL315476																																			
SOLD TO ADDRESS MCJUNKIN RED MAN CORP PO BOX 513 HOUSTON TEXAS 77001 CHARLESTON WV 25322-0513				BILL TO ADDRESS MCJUNKIN RED MAN CORP PO BOX 513 HOUSTON TEXAS 77001 CHARLESTON WV 25322-0513				VENUE U.S. STEEL TUBULAR PRODUCTS FAIRFIELD TUBULAR OPERATIONS 5700 VALLEY ROAD P.O. BOX 599 FAIRFIELD, AL 35064																																	
SPECIFICATION AND GRADE PIPE CARBON SMILE STD PIPE API 5L-44TH ED DTD OCT 2007 AND ISO 3103:2007 MOD PSL-2 GRADE B AND GRADE K42 R N OR Q ASTM A53-10 GRADE B ASME SA53-2010 EDITION GRADE B ASTM A106-10 GRADE B/C ASME SA106-2010 EDITION GRADE B/C BLE REG MILL COAT PE RRV 30 DEG MEETING ALL THE APPLICABLE REQUIREMENTS OF NACE STANDARD MR-01-75 "130 16156-2 2009 ED AND MR-0103-2009_ED																																									
MATERIAL COND: AR-ROLLED				OD: 6.625 (219.075)				WALL: 0.322 (8.178)																																	
PRODUCT IDENTIFICATION		TEST TYPE ORIENTATION		TEST COND.		GAGE WIDTH		YIELD		TENSILE		ELONG %		HARDNESS		IMPURITY																									
								PSY		PSY		IN 2"		HRC		PSY																									
								MIN: 42,100 MAX: 73,800		MIN: 70,000 MAX: 120,200		MIN: 27.0 MAX: 42.0				MIN: 2300 MAX: 3300																									
C46068 *NOTE 8 U41444 *NOTE 8		STRIP/L/B STRIP/L/B		AR AR		1.5 1.5		54,500 52,000		.50 .50		79,500 77,000		0.69 0.86		42.2 42.0		2300 3300																							
** END OF DATA THIS SHEET **																																									
LEGEND: L-LONGITUDINAL U-UPSET T-TRANSVERSE HZ-NORMALIZED ST-SPINCH & TENSILE OR-STRESS RELIEF AR-AS ROLLED TR-TRANSVERSE MECHANICAL ROLLED R-ROOF W-WELD																																									
PRODUCT IDENTIFICATION		TYPE		G		AM		P		E		S		ED		CP		AC		AL		B		Y		B		TS		CO		ER		AS		PH		EL			
C46068		HEAT		19		207		007		006		32		04		01		05		01		03		008		01		0002		001		000		00		00		004		.39	
C46068		PROD		20		210		008		004		33		04		02		06		01		03		007		01		0002		003		002		004		00		.40			
C46068		HEAT		20		211		008		008		34		04		02		06		01		04		006		01		0002		003		004		004		00		.41			
U41444		HEAT		20		208		006		007		35		03		01		08		01		03		007		01		0002		001		000		00		00		.40			
U41444		PROD		20		209		006		008		35		03		01		04		01		03		008		01		0002		001		001		006		00		.40			
U41444		PROD		20		211		007		008		35		03		01		04		01		03		008		01		0002		001		002		006		00		.40			
** END OF DATA THIS SHEET **																																									
*C.E. IS BASED ON THE FOLLOWING EQUATION: C.E. = 0 + MW/6 + (CM-MD - V)/5 + (CD+HX)/15 <= 0.43																																									

DECIMAL POSITIONS FOR ELEMENTS ARE INDICATED BY THE LEFT MARGIN, VERTICAL DOTTED LINE OR DECIMAL POINT. ELEMENTS REPORTED IN MASS FRACTION (%)  
517901004 T0451032 3262440133 0-0-0 PAGE 1 OF 2

Nol-X NDT Service

Company MTUA  
PQR No. N01B-P / N01F-P  
Date 12-4-13 / 12-25-13  
By A.C.M.

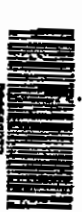



UNITED STATES STEEL

TUBULAR PRODUCTS  
CERTIFIED TEST REPORT  
IN ACCORDANCE WITH ISO 10476/EN 10203/ASME B31.1

DATE: 06/07/12  
TIME: 13:57:55  
SERIAL NO: F0074634

MILL ORDER/ITEM NO D404462 08		ORDER NO. Y12767		P.O. NUMBER ETN0429370		WALL THICKNESS 0.322 ( 0.178)		W. WEIGHT B. 625 (210.075)											
MATERIAL SPEC. A5-ROLLING		DR		DR		DR		DR											
PROJECT IDENTIFICATION	FLAY	SENO	DRUM SIZE	MM COLLAPSE	DR	TEST TYPE	YIELD	NON	TEST RESULT	CHARPY NOTCH IMPACT TESTS				W. WEIGHT					
													1	2	3	AVG	1	2	3
										11	11	11	14						
C46068	OK				T	B	+ 32	2/3	AR	23	22	24	23	10	10	10	10		
C46068					T	B	+ 32	2/3	AR	24	25	21	23	10	10	10	10		
U41444	OK				T	B	+ 32	2/3	AR	24	25	21	23	10	10	10	10		
U41444					T	B	+ 32	2/3	AR	25	23	22	23	10	10	10	10		
** END OF DATA THIS SHEET **																			
LOCUS: L-LENGTHWISE T-TRANSVERSE S-BODY W-WELD HAZ-HAZ AFFECTED ZONE																			
TESTING / INSPECTION INFORMATION																			
TEST / INSPECTION										RESULTS / COMMENTS									
FULL LENGTH VISUAL										X									
FULL LENGTH ESE										X DE DR X L UT X 10.0/10.0% NOTCH									
FULL LENGTH MP										ID DRNO L UT									
FULL LENGTH UT										ID DRNO L UT									
END AREA INSPECTION (PLAIN END)										X MPI X UT									
SPECIAL END AREA (SEA) INSPECTION										MPI UT									
FULL LENGTH DRIFT										DRIFT MANDEL SIZE									
ADDITIONAL NOTES/COMMENTS																			
<p>ALL MELTING AND MANUFACTURING TOOK PLACE IN THE USA.          MANUFACTURED IN AN ISO 9001 CERTIFIED FACILITY - CERTIFICATE #30727.          NO REPAIRS BY WELDING. NO MERCURY OR MERCURY COMPOUNDS ARE ADDED TO THE STEEL AND ALL MERCURY          SMELTING EQUIPMENT IS PROTECTED BY A DOUBLE BOUNDARY OF CONTAINMENT.          *NOTE A SEE ATTACHED REPORT FOR TENSILE RESULTS.          *NOTE B SEE ATTACHED REPORT FOR TENSILE RESULTS.          ** END OF DATA **</p>																			

THIS IS TO CERTIFY THAT THE PRODUCT DESCRIBED HEREIN WAS MANUFACTURED,  
 SAMPLED, TESTED AND/OR INSPECTED IN ACCORDANCE WITH THE SPECIFICATION  
 AND FULFILLS THE REQUIREMENTS IN SUCH RESPECTS.

PREPARED BY THE OFFICE OF: J. MAJORS - MANAGER, Q.A.

DATE: 06/07/12

517901004

TQ456D32

5362440122

0-0-0

PAGE 2 OF 2

NoI-X NDT Service

Company NTUA

QR No. NO18-P / NO16-P  
 Date 12-4-13 / 12-05-13

By: *[Signature]*



UNITED STATES STEEL

TUBULAR PRODUCTS  
TENSILE TEST REPORT

DATE: 06/07/12  
TIME: 13:58:00  
PAGE: 1

MAIL TO ORDER DR06462 00	ORDER NO. Y32767	CO. NUMBER 57N0429370	HEAT	SERIAL NUMBER: P0074478
BUYER ADDRESS MCJUNKIN RED MAN CORP PO BOX 513 HOUSTON TEXAS 77058 CHARLESTON WV 25322-0513		MAIL TO ORDER		VENDOR USS TUBULAR PRODUCTS USS FAIRFIELD WORKS P.O. BOX 599 FAIRFIELD ALABAMA 35064

HEAT	PIPE/LOT	TYPE/DIM/LOC	TEST COND	YIELD	EXT%	TENSILE	Y/T	ELONG %	REDUC AREA
C48068	7804	STRIP/L/S	AR	54,500	0.50	79,500	0.69	43.2	
C48068	7798	STRIP/L/S	AR	52,800	0.50	79,000	0.66	39.2	
C48068	7795	STRIP/L/S	AR	47,900	0.50	77,500	0.62	40.0	
W41444	7801	STRIP/L/S	AR	51,000	0.80	77,000	0.66	43.0	
W41444	7807	STRIP/L/S	AR	48,900	0.50	77,000	0.63	39.9	

101-X NDT Service

Company NTUA  
 QR No. ND1B-P / NDIF-P  
 Date 12-4-13 / 12-25-13  
 by ACM

Company NTUA  
PQR No. ND18-P / NOLF-P  
Date 12-4-13 / 12-5-13  
By [Signature]

FARMINGTON

BRIGHTON  
Grand Junction



ANCHORAGE

CASF

Serving the Rocky Mountain Area

Farmington Office • PHONE: (505) 327-0486 • 1390 E. Murray Dr. • Farmington, NM 87401 •

www.quadcoinc.com

## CALIBRATION TEST REPORT

TEST REPORT #: \_\_\_\_\_ REPAIR ORDER#: 10011693.

CUSTOMER: NOL-X PHONE: 220-2,182.

ADDRESS: \_\_\_\_\_ FAX: \_\_\_\_\_

CITY: FARMINGTON STATE: NM.

CUSTOMER CONTACT: GEORGE.

SYSTEM: CRCEVANS. CAPACITY: 15000 SER.#: CRC418.

LOAD APPLIED (psi)	AS FOUND (psi)	AS LEFT (psi)
25% <u>3750</u>	<u>3750</u>	<u>3750</u>
50% <u>7500</u>	<u>7500</u>	<u>7500</u>
75% <u>11250</u>	<u>11250</u>	<u>11250</u>
100% <u>15000</u>	<u>15000</u>	<u>15000</u>

ROOM TEMP: 70 deg F. TEST DATE: 7/12/13. TEST BY: [Signature]

CHECKED BY: [Signature] INSIDE CHECK: [Signature]

TEST EQUIPMENT: ~~DHT~~ MLISK-1 S/N: 0117 / MLISK-1

THIS INSTRUMENT HAS BEEN CALIBRATED WITH A PRESSURE STANDARD  
WHOSE ACCURACY IS TRACEABLE TO THE N.I.S.T. TEST NUMBERS.

MODEL: RS DWT 2-1 S/N: 5212

TEST NUMBERS: P-8365, P-8109, P-8085

RECOMMENDED CALIBRATION:

APPROVED BY: CHRIS DOYLE  
Signature

WITNESSED BY: STEVE VITZY  
Signature

**NOL-X NDT SERVICE**

105 Parkland Circle  
Farmington, NM 87401

660A TRMS Amperage & Voltage Clamp Meter (#61-765)



**ISO 9001**  
Registered Quality  
Management System

**Certificate of Conformance**

IDEAL INDUSTRIES, INC. hereby certifies that this product was checked and/or calibrated in accordance with applicable calibration practices using equipment that is calibrated to standards traceable to the National Institute for Standards and Technology (NIST). These procedures are ISO-9001 controlled and are designed to assure that the instrument meets its published specifications.

This meter is warranted to the original purchaser against defects in material or workmanship for the period stated in the instruction manual, excepting normal wear and abuse.

Serial Number

SERIAL NO: 120900333

IDEAL INDUSTRIES, INC.  
Becker Place  
Sycamore, IL 60178, U.S.A.  
877-201-9005 Technical Hotline  
www.testersandmeters.com  
ND 2435-2

In-service Date 07-11-2013

Calibration Due Date 07-11-2014

By G C Noland

Nol-X NDT Service

Company NTUA

PQR No. NO18-P / NO1F-P

Date 12-4-13 / 12-5-13

By G C Noland

**NOL-X NDT SERVICE**

105 Parkland Circle  
Farmington, NM 87401

Infrared (IR) Thermometer (#61-685)

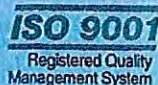

**Certificate of Conformance**

IDEAL INDUSTRIES, INC. hereby certifies that this product was checked and/or calibrated in accordance with applicable calibration practices using equipment that is calibrated to standards traceable to the National Institute for Standards and Technology (NIST). These procedures are ISO-9001 controlled and are designed to assure that the instrument meets its published specifications.

This meter is warranted to the original purchaser against defects in material or workmanship for the period stated in the instruction manual, excepting normal wear and abuse.

Serial Number  
SN: E0082003215

IDEAL INDUSTRIES, INC.  
Becker Place  
Sycamore, IL 60178, U.S.A.  
877-201-9005 Technical Hotline  
www.testersandmeters.com  
ND 2435-2

In-service Date 07-11-2013

Calibration Due Date 07-11-2014

By G C Noland

Nol-X NDT Service

Company NTUA  
PQR No. NOIR-P / NOIF-P  
Date 12-4-13 / 12-5-13

By A C Noland

# NAVAJO TRIBAL UTILITY AUTHORITY

Procedure Specification No. N02B-S

API 1104, 20<sup>th</sup> Edition

Supporting Welding Procedure No. N02B-P

For Butt Welding of Steel Pipe and Fittings

Process: Shielded Metal Arc Welding (SMAW) Manual

Material: API, 5L, Grade B through X42 and Grades Y35 through Y42.

Diameter and wall thickness: 1 1/4" through 24", .140" through .750" WT

Joint design: Single "V" Bevel

Filler Metal and no. of beads: AWS A5.1:E6010/E7018, 3 Beads minimum or as need to complete balance of weld. E7018 electrodes shall be stored in the original sealed container or in a hot box at 250' to 300' F. Two beads shall not be started at the same location. Feather starts and stops on root pass.

Electrical or flame characteristics: Direct Current, Reverse Polarity

Position: All (Fixed)

Direction of welding: E6010- Downhill/E7018-Uphill starting at bottom without excessive weaving of the electrode

No. of welders: One or more as required. Two welders on pipe 12" and greater for weld passes 1 & 2

Maximum time lapse between passes: 15 minutes between the first and second pass

: 18 hours between passes balance of weld

Type and removal of lineup clamp: None required or External clamp - 50% of pipe wall welded or

Internal clamp - 100% of pipe wall welded

Cleaning and/or grinding: Power grind root pass, Power brush and/or grind balance of weld

Preheat stress relief: 50' F minimum, 200' F minimum +150' F maximum when ambient temperature is below 50' F or when repairing or completing unfinished welds. 250' F minimum +150' F maximum when the thickness is .500" or greater. When joints of unequal thickness are welded the higher preheat shall be used. Preheat may be required to remove moisture from pipe. Maximum interpass temperature 650'F. Preheat bottom center to top of weld.

Preheat maintenance: Torch, heat in a wide area at least 2 to 4 inches on both sides of weld joint. Monitor with temperature sticks, pyrometer, digital thermometer or other suitable methods.

Alignment: Pipe of the same nominal wall thickness, offset shall not exceed 1/8"

Joints of unequal thickness: Tapered transition having a length not less than three times the offset shall be provided at joints between sections that differ in thickness by more than 3/32" of the thickness of the thinner section. The transition may be formed by any process that will provide a uniform taper.

**Sketches and tabulations:**

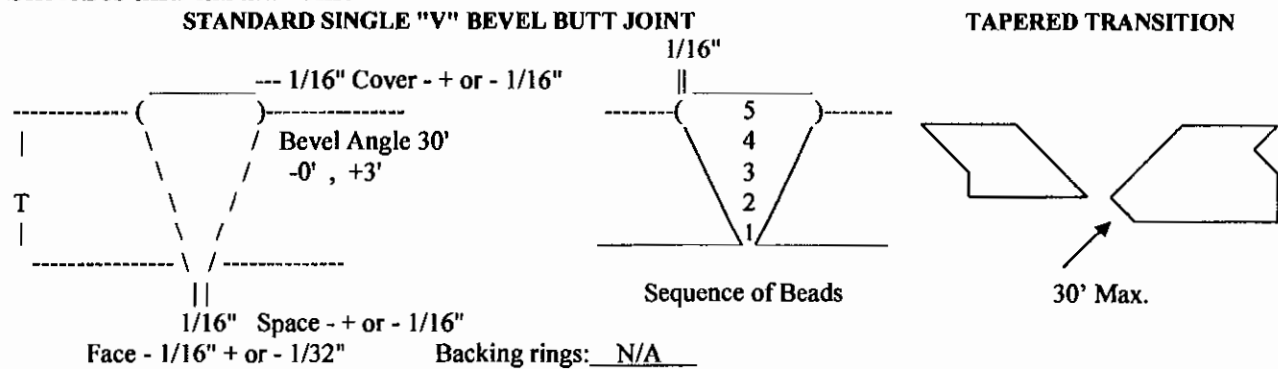

**ELECTRODE SIZE AND NUMBER OF BEADS (3 BEADS MINIMUM)**

Beads	Filler metal	Voltage	Amperage	Speed
Root pass	E6010 3/32"	18 - 30	40 - 70	8"/Minute Maximum
Root Pass	E6010 1/8"	22 - 32	75 - 130	10"/Minute Maximum
Root Pass	E6010 5/32"	22 - 32	90 - 175	10"/Minute Maximum
Fillers	E7018 3/32"	20 - 28	70 - 100	2" to 8" / Minute
Fillers	E7018 1/8"	20 - 28	90 - 150	2" to 8" / Minute
Fillers	E7018 5/32"	20 - 28	120 - 190	2" to 8" / Minute
Cover Pass	E7018 3/32"	20 - 28	70 - 100	2" to 8" / Minute
Cover Pass	E7018 1/8"	20 - 28	90 - 150	2" to 8" / Minute
Cover Pass	E7018 5/32"	20 - 28	120 - 190	2" to 8" / Minute

Tested By George C Noland 12/05/2013  
 Approved \_\_\_\_\_  
 Adopted \_\_\_\_\_

Welder Melvin Benally  
 Welding supervisor \_\_\_\_\_  
 Chief engineer \_\_\_\_\_



# NAVAJO TRIBAL UTILITY AUTHORITY

Procedure Specification No. N02F-S

API 1104, 20<sup>th</sup> Edition

Supporting Welding Procedure No. N02F-P

For Fillet Welding of Steel Pipe and Fittings

Process: Shielded Metal Arc Welding (SMAW) Manual

Material: API, 5L, Grade B through X42 and Grades Y35 through Y42.

Diameter and wall thickness: 1 1/4" through 24", .140" through .750" WT

Joint design: Fillet (See Sketches)

Filler Metal and no. of beads: AWS A5.1: E7018, 3 Beads minimum or as need to complete balance of

weld E7018 electrodes shall be stored in the original sealed container or in a hot box at 250' to 300' F.

Two beads shall not be started at the same location.

Electrical or flame characteristics: Direct Current, Reverse Polarity

Position: All (Fixed)

Direction of welding: Downhill, without excessive weaving of the electrode

No. of welders: One or more as required. Two welders on pipe 12" and greater

Maximum time lapse between passes: First pass shall be completed without interruption except to change

electrodes. Between the first and second pass as soon as possible not to exceed 10 minutes. 15 minutes

between passes balance of weld.

Type and removal of lineup clamp: None required or External clamp - 50% of pipe wall welded or

Internal clamp - 100% of pipe wall welded

Cleaning and/or grinding: Clean 1" around the outside of weld area. Power grind root pass. Power brush

and/or grind balance of weld

Preheat stress relief: 50' F minimum, 200' F minimum, +150' F maximum when ambient temperature is

below 50' F or when repairing or completing unfinished welds. 250' F minimum, +150' F maximum when

the thickness is .500" or greater. When joints of unequal thickness are welded the higher preheat shall be

used. Preheat may be required to remove moisture from pipe. Maximum interpass temperature 650'F.

Preheat maintenance: Torch, heat in a wide area at least 2 to 4 inches on both sides of weld joint. Monitor

with temperature sticks, pyrometer, digital thermometer or other suitable methods

Speed of travel: 2 to 8" per minute

Sketches and tabulations:

JOINT: Fillet Size 1.4 T Max. (T= thinner WT)

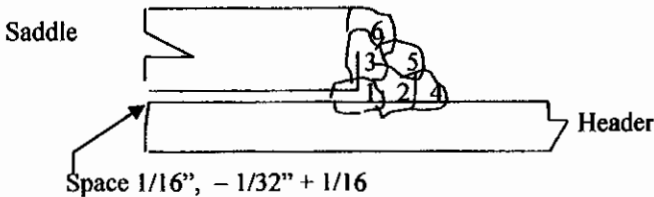

Example Temper Bead Sequence

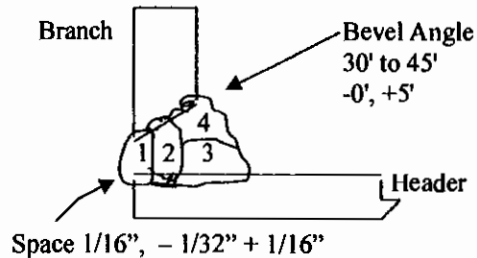

### ELECTRODE SIZE AND NUMBER OF BEADS (3 BEADS MINIMUM)

Beads	Filler metal	Voltage	Amperage	Speed
Root Pass	E6010 3/32"	22 - 30	40 - 70	6"/Minute Maximum
Root Pass	E6010 1/8"	22 - 30	70 - 130	8"/Minute Maximum
Fillers	E7018 3/32"	20 - 28	70 - 100	2" to 8" / Minute
Fillers	E7018 1/8"	20 - 28	90 - 150	2" to 8" / Minute
Fillers	E7018 5/32"	20 - 30	120 - 190	2" to 8" / Minute
Cover Pass	E7018 3/32"	20 - 28	70 - 100	2" to 8" / Minute
Cover Pass	E7018 1/8"	20 - 28	90 - 150	2" to 8" / Minute
Cover Pass	E7018 5/32"	20 - 30	120 - 190	2" to 8" / Minute

Tested By George C Noland 12/06/2013

Approved \_\_\_\_\_

Adopted \_\_\_\_\_

Welder Melvin Benally

Welding supervisor \_\_\_\_\_

Chief engineer \_\_\_\_\_

**NoI-X NDT Service**  
**Farmington, New Mexico**  
**COUPON TEST REPORT**  
**(PROCEDURE QUALIFICATION)**

Code Specification <u>API 1104, 20th</u>	Procedure No. <u>N02B-P / N02F-P</u>
Facility (Name & Address) <u>Navajo Tribal Utility Authority</u>  <u>FT. Defiance, Arizona 86504-1520</u>	Welders Name. <u>Melvin Benally</u> <u>***-**-1328</u>
<u>N/A</u> Single Qualification <u>YES</u> Multiple Qualification <u>Yes</u> Qualified <u>N/A</u> Disqualified Weld X-rayed <u>X</u> Yes <u>N/A</u> No	Stencil No. <u>MB</u> Procedure Qualification <u>Yes</u> Welder Qualification <u>Yes</u> X-ray Qualification <u>No</u>
Pipe Manufacture & Type: <u>United States Steel</u> <u>API 5L, X-42, Minimum Yield 42,000 PSI</u>	Number of Welders <u>One</u> Position <u>5G / Branch Connection</u> Fixed <u>Yes</u> Rolled <u>N/A</u> Direction of Welding <u>Downhill</u> Time between Passes <u>See Back</u> Line-up Clamps <u>Internal</u> <u>External</u> <u>None Req. X</u>
Process - <u>Yes</u> Manual (SMAW) <u>N/A</u> Semi-Automatic <u>N/A</u> Automatic	Removal of line up clamps <u>N/A</u>
Material - <u>X42, HT- C46068</u> Minimum Tensile- <u>60,000 PSI</u> Dia. & Wall Thickness: <u>8 5/8", .322"</u> Joint Design: <u>Single "V" Bevel</u> Filler Metal & No. of beads: <u>See Back</u> Speed of Travel: <u>See Back</u> Ambient Temperature: <u>45° F - 65° F</u>	Cleaning: <u>Yes</u> Power tools <u>Yes</u> Hand Tools Preheat <u>50° F Minimum</u> Post heat <u>N/A</u>

SINGLE "V" BUTT JOINT				TYPE OF WELD TEST		Date	Procedure No.
Stencil	Width	Wall	Area	TENSILE (PSI)		FRACTURE	
	Inches	Thickness	Inches	Max. Load	Ultimate	AREA	
MB	1.016	.329"	.334	27,000	80,838	Base Metal	
MB	1.009	.326"	.329	26,500	80,547	Base Metal	
Maximum Tensile 80,838				Minimum Tensile 80,547		Average Tensile 80,693	
Stencil	Width	W.T.	Type of Test		Remarks		Strap
	Inches	Thickness	Face	Root			Number
MB	1.0	.322	N/A	Accepted	No Indications		03
MB	1.0	.322	N/A	Accepted	No Indications		07
MB	1.0	.322	Accepted	N/A	No Indications		04
MB	1.0	.322	Accepted	N/A	No Indications		08
NICKBREAK							
Stencil	Width Inches	W.T. Inches	Remarks				
MB	1.0	.322	Accepted, No Indications				
MB	1.0	.322	Accepted, No Indications				
NICKBREAK (BRANCH CONNECTION)							
Stencil	Width Inches	Branch WT Inches	Header WT Inches	Remarks			Strap
							Number
MB	1.0	.322	.322	Accepted, No Indications			01
MB	1.0	.322	.322	Accepted, No Indications			02
MB	1.0	.322	.322	Accepted, No Indications			03
MB	1.0	.322	.322	Accepted, No Indications			04

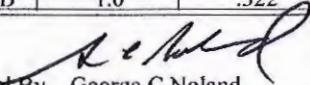
Tested By  George C Noland

Company Representative Jason Corral  
 (See back for additional remarks)



**George C Noland**  
 SCWI 98120118  
 QC1 EXP. 12/1/2016

**STANDARD SINGLE "V" BEVEL BUTT JOINT**

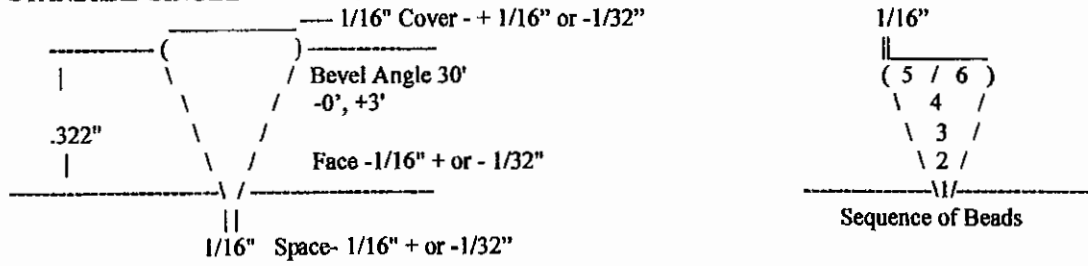

Backing rings: N/A

Beads	Filler Metal	Voltage	Amperage	Speed	Interpass Temperature
1 Root	E6010, 5P+, 1/8"	24 - 26	75 - 80	4 - 5" per minute	85'
2 Hot Pass	E7018, 3/32"	20 - 22	75 - 80	3 - 6" per minute	400'
3-4 Fillers	E7018, 3/32"	20 - 24	70 - 80	4 - 5" per minute	425'
5-6 Cover	E7018, 3/32"	22 - 24	65 - 70	4 - 5" per minute	420'

**Procedure**

Qualification Thickness Limits - .140" thru .750"

Position Limitations - Fixed

Pipe Diameter Limits - None

Time Between Passes: 10 Minutes Root / Hot Pass

Filler Passes 15 Minutes

Cover passes 15 - 30 Minutes

Number of Beads: Three beads minimum

**Remarks:**

Welding Machine Type: Lincoln, Air Vantage 500

Type of Current & Polarity: DC, Reverse

Visual Inspection of Welds: Accepted

Root Pass - Power Grind

Between Passes - Power grind or brush

Shielding Gas and Flow Rate: N/A

Flame Characteristics: N/A

**BRANCH CONNECTION**

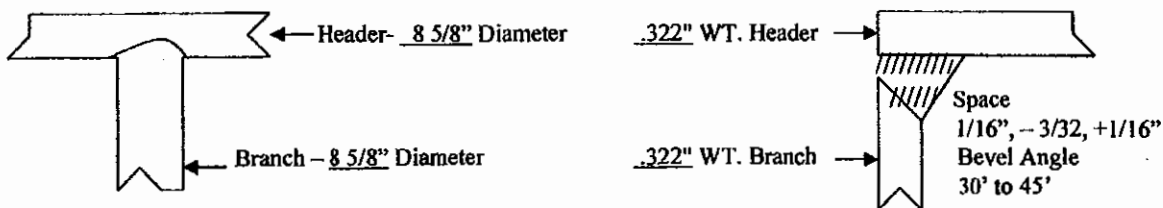

Beads	Filler Metal	Voltage	Amperage	Speed	Interpass Temperature
1 Root	E6010, 5P+, 1/8"	26 - 30	90 - 100	4 - 5" per minute	90'
2 Hot Pass	E7018, 3/32"	22 - 24	75 - 85	3 - 6" per minute	270'
3 Fillers	E7018, 3/32"	22 - 25	75 - 85	4 - 5" per minute	350'
4 Cover	E7018, 3/32"	22 - 24	75 - 85	4 - 5" per minute	340'



UNITED STATES STEEL

TUBULAR PRODUCTS  
CERTIFIED TEST REPORT  
(IN ACCORDANCE WITH ISO 16474/EN10240/ASME B31.1)

DATE: 06/07/13  
TIME: 13:37:55  
SERIAL NO: P0074424

U.S. ORDER/PO NO DR04452 09	ORDER NO. X32767	P.O. NUMBER B7N0429370	WHOLESALE BQRL315476																	
SOLD TO ADDRESS MCJUNKIN RED MAN CORP PO BOX 513 HOUSTON TEXAS 77058 CHARLESTON WV 25322-0513		MAIL TO ADDRESS MCJUNKIN RED MAN CORP PO BOX 513 HOUSTON TEXAS 77058 CHARLESTON WV 25322-0513																		
VENDOR U.S. STEEL TUBULAR PRODUCTS FAIRFIELD TUBULAR OPERATIONS 5700 VALLEY ROAD P.O. BOX 599 FAIRFIELD, AL 36064																				
SPECIFICATION AND GRADE PIPE CLASSON (SMLS HTD PIPE) API 5L-44TH ED DTD OCT 2007 AND ISO 3183:2007 MOD BSL-2 GRADE B AND GRADE X42 H N OR Q ASTM A51-10 GRADE B ASME B31.1-2010 EDITION GRADE B ASTM A106-10 GRADE B/C ASME SA106-2010 EDITION GRADE B/C BLS REG MILL COAT PR REV 3D DRG MEETING ALL THE APPLICABLE REQUIREMENTS OF WACK STANDARD MR-01-75 *180 15156-2 2009 ED AND MR-0103-2009_ED																				
MATERIAL COND: AS-ROLLED		OD: 8.625 (219.075)	WALL: 0.312 ( 8.178)																	
PRODUCT IDENTIFICATION	TEST TYPE/ ORIENTATION	TEST COND	CHARM PITCH	YIELD MIN: 42,100 MAX: 71,800	TENSILE MIN: 70,000 MAX: 110,200	Y/T	ELONG % MIN: 27.0	HARDNESS ROCKWELL MAX: 2350	DRILLING DRY	DRILLING DRY										
C46088 *NOTE #	STRIP/L/B	AR	1.5	54,500	78,500	0.69	43.2		2360	5										
Q41444 *NOTE #	STRIP/L/B	AR	1.5	51,000	77,000	0.66	42.0		2360	5										
** END OF DATA FILE **																				
LEGEND: L-LENGTHENED U-SHEET T-TENSILE/HR-NORMALIZED OT-QUENCH & TEMPERED AR-AS ROLLED R-RODY W-WELD TR-THERMO-MECHANICAL ROLLED																				
PRODUCT IDENTIFICATION	TYPE	C	MN	P	S	SI	CU	NI	CR	MO	AL	N	V	B	S	CO	ZN	PB	SE	MAX
C46088	HEAT	19	207	007	006	22	04	01	05	01	016	008	01	0002	001	000	00	00	004	.39
C46088	PROD	20	210	008	004	23	04	02	06	01	035	007	01	0002	003	002	004	00	00	.40
C46088	PROD	20	211	008	005	24	04	02	06	01	042	006	01	0002	003	004	004	00	00	.41
Q41444	HEAT	20	208	008	007	25	03	01	04	02	035	007	01	0002	001	000	00	00	005	.40
Q41444	PROD	20	209	006	008	25	03	01	04	02	034	008	01	0002	001	001	006	00	00	.40
Q41444	PROD	20	211	007	008	25	03	01	04	02	034	008	01	0002	001	002	006	00	00	.40
** END OF DATA FILE **																				

\*C.F. IS BASED ON THE FOLLOWING EQUATION: C, P. = C + MN/6 + (CN+MO+ V)/5 + (CU+NI)/15 <= 0.43

DECIMAL POSITIONS FOR ELEMENTS ARE INDICATED BY THE LEFT MARGIN, VERTICAL DOTTED LINE OR DECIMAL POINT. ELEMENTS REPORTED IN MASS FRACTION (%)  
517901004 TQ458932 8362440122 0-0-0 PAGE 1 OF 2

Vol-X NDT Service

Company: NTUA  
PQR No: NO.2B-P / NO.2E-P  
Date: 12-5-13 / 12-19-13  
By: [Signature]



UNITED STATES STEEL

TUBULAR PRODUCTS  
CERTIFIED TEST REPORT  
(IN ACCORDANCE WITH ISO 10474:2004/EN 10203:2004 "Type 3.1")

DATE: 06/07/13  
TIME: 13:57:58  
SERIAL NO: P0074434

MILL ORDER NUMBER PH04462 08	INVENTORY NO Y22767	P.O. NUMBER STN0428370															
MATERIAL COMP: AS-ROLLED		GRN: B.625 (310.075)		WALL: 0.322 (8.178)													
PRODUCT IDENTIFICATION C46068 C46068 U41444 U41444	FLAY OK OK	BEND	GRAB SIZE	MIN COLLAPSE	DR	TEST LOC	YIELD	SIZE	TEST CORR	HEAVY METAL REPAI TESTING				% BREAK			
										1	2	3	AVG	1	2	3	AVG
DEG F										11	11	11	11	10	10	10	10
										23	22	24	23	10	10	10	10
										24	25	21	23	10	10	10	10
										24	25	21	23	10	10	10	10
										25	23	22	23	10	10	10	10
** END OF DATA THIS SHEET **																	
L-CONDITIONAL				T-TRANSVERSE				B-BODY				W-WELD		HAZ-HEAT AFFECTED ZONE			
TEST / INSPECTION				TESTING / INSPECTION INFORMATION				RESULTS / COMMENTS									
PERL LENGTH VISUAL				YES				X									
FULL LENGTH EDR				YES				EDR --- ODR --- X --- UT --- X --- 10.0/10.0% NOTCH									
FULL LENGTH MPI								ID --- ODR --- I --- UT									
FULL LENGTH UT																	
END AREA INSPECTION (PLAN END)				X				MPI --- X --- UT									
SPECIAL END AREA (SEAL END)								MPI --- UT									
FULL LENGTH DRIFT								DRIFT MANDREL SIZE									
ADDITIONAL NOTES/COMMENTS																	
<p>ALL MELTING AND MANUFACTURING TOOK PLACE IN THE USA.          MANUFACTURED IN AN ISO 9001 CERTIFIED FACILITY - CERTIFICATE #30727.          NO REPAIRS BY WELDING. NO MERCURY OR MERCURY COMPOUNDS ARE ADDED TO THE STEEL AND ALL MERCURY          HEATING EQUIPMENT IS PROTECTED BY A DOUBLE BOUNDARY OF CONTAINMENT.          *NOTE A SEE ATTACHED REPORT FOR TENSILE RESULTS.          *NOTE B SEE ATTACHED REPORT FOR TENSILE RESULTS.          ** END OF DATA **</p>																	

THIS IS TO CERTIFY THAT THE PRODUCT DESCRIBED HEREIN WAS MANUFACTURED,  
SAMPLED, TESTED AND/OR INSPECTED IN ACCORDANCE WITH THE SPECIFICATION  
AND FULFILLS THE REQUIREMENTS IN SUCH RESPECTS.

PREPARED BY THE OFFICE OF: J. MAJURZAK - MANAGER, Q.A.

DATE: 06/07/13

517901004

70456032

5362440122

0-0-0

PAGE

2 OF

2

Not-X NDT Service

Company: NTUA  
QR No. N02B-P / N02F-P  
Date: 12-5-13 / 12-6-13  
By: [Signature]



UNITED STATES STEEL

TUBULAR PRODUCTS  
TENSILE TEST REPORT

DATE: 06/07/12  
TIME: 13:58:06  
PAGE: 1

MAIL ORDER ITEM NO. DR04462 08	PIPE SPEC. Y32767	CO. NUMBER 87N0429370	HEAT	SERIAL NUMBER: R0074434
MAIL TO ADDRESS MCJUNKIN RED MAN CORP PO BOX 513 HOUSTON TEXAS 75868 CHARLESTON WV 25321-0513		MAIL TO ADDRESS		VENUE USS TUBULAR PRODUCTS USS FAIRFIELD WORKS P.O. BOX 398 FAIRFIELD ALABAMA 35064

HEAT	PIPE/LOT	TYPE/DIM/LOC	TEST COND	YIELD	EXT%	TENSILE	Y/T	ELONG %	REDUC AREA
C46068	7804	STRIP/L/D	AR	54,500	0.50	78,500	0.69	43.3	
C46068	7796	STRIP/L/D	AR	52,800	0.50	79,000	0.66	39.2	
C46068	7795	STRIP/L/D	AR	47,800	0.50	77,500	0.62	40.0	
U41444	7801	STRIP/L/D	AR	51,000	0.50	77,000	0.66	42.0	
U41444	7807	STRIP/L/D	AR	48,800	0.50	77,000	0.62	39.9	

fol-X NDT Service

Company NTUA  
 QR No. N02B-P / N02F-P  
 Date 12-5-13 / 12-6-13  
 by REML

Company NTUA  
PQR No. N02B-P / N02F-P  
Date 12-5-13 / 12-6-13

By [Signature]

FARMINGTON

BRIGHTON  
Grand Junction

ANCHORAGE

CASF



Serving the Rocky Mountain Area

Farmington Office • PHONE: (505) 327-0486 • 1390 E. Murray Dr. • Farmington, NM 87401 •

www.quadcoinc.com

## CALIBRATION TEST REPORT

TEST REPORT #: \_\_\_\_\_ REPAIR ORDER#: 10011093.

CUSTOMER: NOL-X PHONE: 720-2182.

ADDRESS: \_\_\_\_\_ FAX: \_\_\_\_\_

CITY: FARMINGTON STATE: NM.

CUSTOMER CONTACT: GEORGE.

SYSTEM: CRCEVANS. CAPACITY: 15000 SER.#: CRC418.

LOAD APPLIED (psi)	AS FOUND (psi)	AS LEFT (psi)
25% <u>3750</u>	<u>3750</u>	<u>3750</u>
50% <u>7500</u>	<u>7500</u>	<u>7500</u>
75% <u>11250</u>	<u>11250</u>	<u>11250</u>
100% <u>15000</u>	<u>15000</u>	<u>15000</u>

ROOM TEMP: 70 deg F. TEST DATE: 7/12/13. TEST BY: CP.

CHECKED BY: CP INSIDE CHECK: CP.

TEST EQUIPMENT: ~~DWT~~ MLISK-1 S/N: 0117 / MLISK-1

THIS INSTRUMENT HAS BEEN CALIBRATED WITH A PRESSURE STANDARD  
WHOSE ACCURACY IS TRACEABLE TO THE N.I.S.T. TEST NUMBERS.

MODEL: RS DWT 2-1 S/N: 5212

TEST NUMBERS: P-8365 P-8109 P-8085

RECOMMENDED CALIBRATION:

APPROVED BY: CHRIS DOYLE  
Signature

WITNESSED BY: STEVE VITZY  
Signature

**NOL-X NDT SERVICE**

105 Parkland Circle  
Farmington, NM 87401

660A TRMS Amperage & Voltage Clamp Meter (#61-765)



**Certificate of Conformance**

IDEAL INDUSTRIES, INC. hereby certifies that this product was checked and/or calibrated in accordance with applicable calibration practices using equipment that is calibrated to standards traceable to the National Institute for Standards and Technology (NIST). These procedures are ISO-9001 controlled and are designed to assure that the instrument meets its published specifications.

This meter is warranted to the original purchaser against defects in material or workmanship for the period stated in the instruction manual, excepting normal wear and abuse.

Serial Number

SERIAL NO: 120900333

IDEAL INDUSTRIES, INC.  
Becker Place  
Sycamore, IL 60178, U.S.A.  
877-201-9005 Technical Hotline  
www.testersandmeters.com  
ND 2435-2

In-service Date 07-11-2013

Calibration Due Date 07-11-2014

By G C Noland

Nol-X NDT Service

Company NTUA

PQR No. No 2 B-P / No 2 F-P

Date 12-5-13 / 12-20-13

By



# NOL-X NDT SERVICE

105 Parkland Circle  
Farmington, NM 87401

Infrared (IR) Thermometer (#61-685)



## Certificate of Conformance

IDEAL INDUSTRIES, INC. hereby certifies that this product was checked and/or calibrated in accordance with applicable calibration practices using equipment that is calibrated to standards traceable to the National Institute for Standards and Technology (NIST). These procedures are ISO-9001 controlled and are designed to assure that the instrument meets its published specifications.

This meter is warranted to the original purchaser against defects in material or workmanship for the period stated in the instruction manual, excepting normal wear and abuse.

Serial Number

SN: E0082003216

IDEAL INDUSTRIES, INC.  
Becker Place  
Sycamore, IL 60178, U.S.A.  
877-201-9005 Technical Hotline  
www.testersandmeters.com  
ND 2435-2

In-service Date 07-11-2013

Calibration Due Date 07-11-2014

By G C Noland

Nol-X NDT Service

Company NTUA

PQR No. N02B-P / N02F-P

Date 12-5-13 / 12-6-13

By ACR

# NAVAJO TRIBAL UTILITY AUTHORITY

Procedure Specification No. N01BR-S Revision ---

API 1104, 20th

Welding Procedure No. N01BR-P

For Second attempt repair of Butt (Other than cracking) Welding of Steel Pipe and Fittings

Process: Shielded Metal Arc Welding (SMAW) Manual

Material: API, 5L, Grade B through X42, Y35 through Y42. (CE .42 Maximum)

Diameter and wall thickness: 2 3/8" through 24" .154" through .750" WT

Joint design: Single "V" Bevel

Filler Metal and no. of beads: AWS A5.1: E6010, / AWS, A5.5: E7010, Sufficient number of beads to complete repair area of weld. Two beads shall not be started at the same location. Feather weld bead starts and stops

Electrical or flame characteristics: Direct Current, Reverse Polarity

Position: All (Fixed)

Direction of welding: Downhill, without excessive weaving of the electrode

No. of welders: One or more as required (All weld repairs shall be made by qualified welders)

Maximum time lapse between passes: 5 minutes

Cleaning and/or grinding: Power brush and/or grind repair area

Method of exploration of the defect: Power grinder and visual observation (Optional NDT methods- MT or PT)

Method of defect removal: Power grinder and/or hand tools, brushes, files, ect. The repair groove shall be visually examined to confirm complete removal of the defect. Weld diameter 2" thru 4" maximum repair length 20% of total weld length. Weld diameter 6" thru 24"- length of repair groove 2" minimum, maximum repair length 15% of total weld length. Bevel angle 15' minimum. (Optional NDT methods- MT or PT)

Interpass nondestructive testing: Optional NDT methods- MT or PT maybe used. Remove all residue from testing.

Preheat and interpass heat treatment: 200° F minimum, +150° F maximum, .500 WT and greater 250° F minimum, +150° F maximum. When joints of unequal thickness are welded the higher preheat shall be used.

Maximum interpass temperature 650° F.

Preheat maintenance: Torch, heat in a wide area at least 2" to 4" on both sides of repair area. Total weld length shall be preheated and maintained while repair is performed. Monitor with pyrometer, temperature sticks, digital thermometer or other suitable methods

Repair Supervision: Shall be by an individual acceptable to the company and who is experienced in the procedures used for weld repair.

Re-Inspection: Repaired areas shall be inspected by the same means previously used. If the repaired area is rejected the entire weld shall be removed from the system. No third repair attempt shall be made.

### Typical Sketches and tabulations:

#### STANDARD SINGLE "V" BEVEL BUTT JOINT

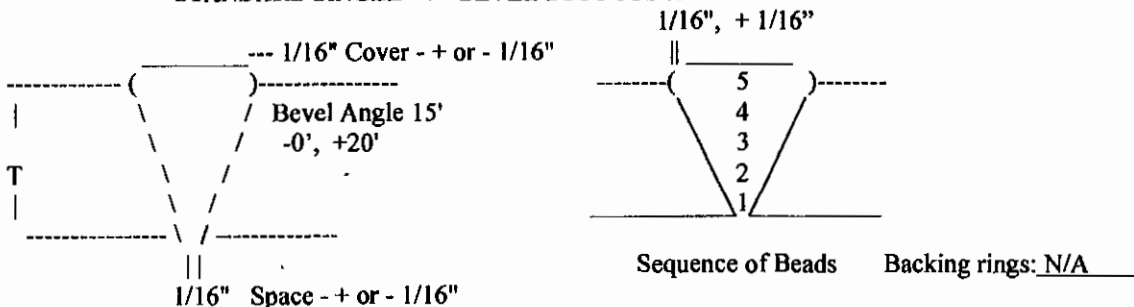

#### ELECTRODE SIZE

Beads	Filler metal	Voltage	Amperage	Speed
Root pass	E6010, 5P+ 3/32"	18 – 26	40 – 70	4" to 8" / Minute
Root Pass	E6010, 5P+ 1/8"	24 – 30	85 – 120	4" to 8" / Minute
Root Pass	E6010, 5P+ 5/32"	24 – 30	90 – 135	4" to 10" / Minute
Hot Pass	E7010-P1 1/8"	24 – 30	90 – 125	4" to 8" / Minute
Hot Pass	E7010-P1 5/32"	24 – 30	110 – 150	3" to 8" / Minute
Hot Pass	E7010-P1 3/16"	24 – 32	120 – 160	3" to 8" / Minute
Fillers	E7010-P1 1/8"	24 – 30	90 – 125	3" to 8" / Minute
Fillers	E7010-P1 5/32"	24 – 30	110 – 150	3" to 8" / Minute
Fillers	E7010-P1 3/16"	24 – 32	120 – 160	3" to 8" / Minute
Cover Pass	E7010-P1 1/8"	24 – 30	90 – 130	3" to 8" / Minute
Cover Pass	E7010-P1 5/32"	24 – 30	100 – 145	3" to 8" / Minute
Cover Pass	E7010-P1 3/16"	24 – 32	120 – 160	3" to 8" / Minute

Tested By George C Noland 12/06/2013  
 Approved \_\_\_\_\_  
 Adopted \_\_\_\_\_

Welder Melvin Benally  
 Welding supervisor \_\_\_\_\_  
 Chief engineer \_\_\_\_\_

**Nol-X NDT Service**  
**Farmington, New Mexico**

**COUPON TEST REPORT**  
**PROCEDURE QUALIFICATION**

<b>Code Specification</b> <u>API 1104, 20th</u>	<b>Procedure No.</b> <u>NO1BR-P</u> Date <u>12/06/2013</u>
<b>Facility (Name &amp; Address)</b> <u>Navajo Tribal Utility Authority</u> <u>FT. Defiance, Arizona 86504-1520</u>	<b>Welders Name.</b> <u>Melvin Benally</u> <u>***.**- 1328</u>
<u>N/A</u> Single Qualification <u>N/A</u> Multiple Qualification <u>Yes</u> Qualified <u>N/A</u> Disqualified Weld X-rayed <u>X</u> Yes <u>N/A</u> No	<b>Stencil No.</b> <u>MB</u> <b>Procedure Qualification</b> <u>Yes</u> <b>Welder Qualification</b> <u>No</u> <b>X-ray Qualification</b> <u>No</u>
<b>Pipe Manufacture &amp; Type:</b> <u>United States Steel</u> <u>API 5L, X-42, 42,000 Minimum Yield</u>	<b>Number of Welders</b> <u>One</u> <b>Position</b> <u>5G</u> <b>Fixed</b> <u>Yes</u> <u>Rolled</u> <u>N/A</u> <b>Direction of Welding</b> <u>Downhill</u> <b>Time Between Passes</b> <u>See Back</u>
<b>Process -</b> <u>Yes</u> <u>Manual (SMAW)</u> <u>N/A</u> Semi-Automatic <u>N/A</u> Automatic	<b>Line-up Clamps</b> <u>Internal</u> <u>External</u> <u>None Req.</u> <u>X</u>
<b>Material -</b> <u>X42, HT- C46068</u> <u>CE- 0.41</u> <b>Minimum Tensile-</b> <u>60,000 PSI</u> <b>Dia. &amp; Wall Thickness:</b> <u>8 5/8", .322"</u> <b>Joint Design:</b> <u>Single "V" Bevel</u> <b>Filler Metal &amp; No. of beads:</b> <u>Lincoln (See Back)</u> <b>Speed of Travel:</b> <u>See Back</u> <b>Ambient Temperature:</b> <u>45' F - 65' F</u>	<b>Removal of line up clamps</b> <u>N/A</u> <b>Cleaning:</b> <u>Yes</u> <u>Power tools</u> <u>Yes</u> <u>Hand Tools</u> <b>Preheat</b> <u>200' F Minimum</u> <u>Post heat</u> <u>N/A</u>

SINGLE "V" BUTT JOINT			TYPE OF WELD TEST				Procedure No. NO1BR-P	
Stencil	Width	Wall	Area	TENSILE (PSI)		FRACTURE	Strap	
	Inches	Thickness	Inches	Max. Load	Ultimate	AREA	Number	
MB	1.140	.316"	0.360	29,500	81,944	Base Metal	01(Through Wall)	
Maximum Tensile -----			Minimum Tensile -----		Average Tensile -----			
Stencil	Width	W.T.	Type of Test		Remarks		Strap	
	Inches	Thickness	Face	Root			Number	
MB	1.0	.322	N/A	Accepted	No Indications		03(Through Wall)	
MB	1.0	.322	Accepted	N/A	No Indications		04(Through Wall)	
NICKBREAK								
Stencil	Width Inches	W.T. Inches	Remarks					
MB	1.0	.322	Accepted, No Indications					02(Through Wall)

*George C Noland*  
 Tested By George C Noland

Company Representative Jason Corral  
 (See back for additional remarks)



**George C Noland**  
 SCWI 98120118  
 QC1 EXP. 12/1/2016

**STANDARD SINGLE "V" BEVEL BUTT JOINT**

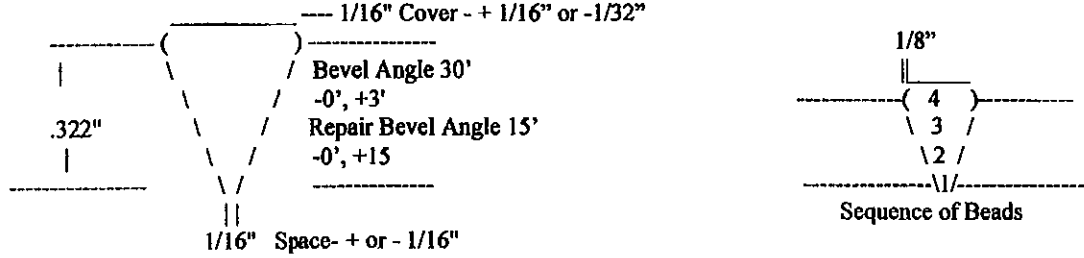

Backing rings: N/A

Beads	Filler Metal	Voltage	Amperage	Speed	Interpass Temperature
1 Root	E6010, 5P+, 1/8"	24 - 26	95 - 105	5 - 6" per minute	80°F
2 Hot Pass	E7010-P1, Hyp+, 5/32"	24 - 28	115 - 125	6 - 7" per minute	300°F
3 Fillers	E7010-P1, Hyp+, 5/32"	24 - 28	115 - 125	5 - 7" per minute	425°F
4 Cover	E7010-P1, Hyp+, 5/32"	26 - 30	105 - 115	5 - 6" per minute	550°F

**Through Wall Repair #1**

Beads	Filler Metal	Voltage	Amperage	Speed	Interpass Temperature
1 Root	E6010, 5P+, 1/8"	22 - 24	95 - 105	5 - 6" per minute	200°F
2 Hot Pass	E7010-P1, Hyp+, 5/32"	24 - 26	115 - 125	6 - 7" per minute	320°F
3 Fillers	E7010-P1, Hyp+, 5/32"	24 - 28	115 - 130	5 - 7" per minute	355°F
4 Cover	E7010-P1, Hyp+, 5/32"	24 - 28	115 - 125	5 - 6" per minute	600°F

**Through Wall Repair #2**

Beads	Filler Metal	Voltage	Amperage	Speed	Interpass Temperature
1 Root	E6010, 5P+, 1/8"	26 - 30	85 - 95	6 - 7" per minute	200°F
2 Hot Pass	E7010-P1, Hyp+, 5/32"	24 - 26	115 - 125	6 - 7" per minute	430°F
3 Fillers	E7010-P1, Hyp+, 5/32"	24 - 26	115 - 125	5 - 7" per minute	430°F
4 Cover	E7010-P1, Hyp+, 5/32"	24 - 26	115 - 125	6 - 7" per minute	450°F

**Procedure**

Qualification Thickness Limits - .154" thru .750"  
 Position Limitations - Fixed  
 Pipe Diameter Limits - None

Time Between Passes: 5 Minutes Root / Hot Pass  
Filler Passes 5 Minutes  
Cover passes 5 Minutes

Number of Beads: Three beads minimum

Remarks:  
 Visual Inspection of Weld: Accepted  
 Micro Etch Test: Butt Weld, Accepted, No Indications  
 Vickers Micro-Hardness: Butt Weld, Accepted, 248 Max. | Average: Base Metal 176 | HAZ 232 | Weld 182  
 Welding Machine Type: Lincoln, Air Vantage 500  
 Type of Current & Polarity: DC, Reverse  
 Root Pass - Power Grind  
 Between Passes - Power grind or brush

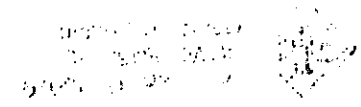



UNITED STATES STEEL

TUBULAR PRODUCTS  
CERTIFIED TEST REPORT  
(IN ACCORDANCE WITH ISO 10474/EN10204/DIN5049 "Type 3.1")

DATE: 06/07/12  
TIME: 13:57:58  
SERIAL NO: F0074439

MATERIAL ORDER NO. DRO4482 08		PURCHASE NO. X32767		P.L. NUMBER 87N0429370		VENDOR ID MOKL315476																	
SOLD TO ADDRESS MCJUNKIN RED MAN CORP PO BOX 513 HOUSTON TEXAS 77058 CHARLESTON WV 25322-0513				MAIL TO ADDRESS MCJUNKIN RED MAN CORP PO BOX 513 HOUSTON TEXAS 77058 CHARLESTON WV 25322-0513				VENDOR U.S. STEEL TUBULAR PRODUCTS FAIRFIELD TUBULAR OPERATIONS 5700 VALLEY ROAD P.O. BOX 899 FAIRFIELD, AL 36064															
SPECIFICATION AND GRADE PIPE CARBON SMLS HTD PIPN API 5L-44TH ED DTD OCT 2007 AND ISO 3183:2007 MOD PSL-3 GRADE B AND GRADE K42 R N OR Q ASTM A51-10 GRADE B ASME B31-2010 EDITION GRADE B ASTM A106-10 GRADE B/C ASME SA106-2010 EDITION GRADE B/C BLE END MILL COMP PR BEV 30 DEG MEETING ALL THE APPLICABLE REQUIREMENTS OF MACK STANDARD MR-01-75 =:100 15156-3 1009 ED AND MR-0103-2009_ED																							
MATERIAL CONDN: AB-ROLLING		D.S.I. S.625 (219.075)		In feet		MILL: D.322 (W.178)		V.I. (feet)															
PRODUCT IDENTIFICATION		TEST TYPE DESCRIPTION		TEST COND.		GAGE THICKNESS		YIELD		UTS		TENSILE		VIT		ELONG%		HARDNESS		MIN HYDRD		DHW:100%	
						IN		MIN		MAX		MIN		MAX		MIN		MIN		MAX		MAX	
C46088 *NOTE A		STEEL/L/B		AR		1.5		42,100		.50		70,000		0.69		27.0		HRC		2380		5	
U41444 *NOTE B		STEEL/L/B		AR		2.5		73,900		.50		110,200		0.46		42.0		HRC		3360		5	
						**		END OF DATA THIS		*****		**											
LEGEND:		L-CONVENTIONAL		T-TRANSVERSE		QT-QUENCH & TEMPERED		AR-AS ROLLED		B-BODY		W-WELD											
		U-UPSET		NM-NORMALIZED		AR-STRIPS REMOVED		TM-THERMO-MECHANICAL ROLLER															
PRODUCT IDENTIFICATION		TYPE																					
C46088		HEAT		19		107		007		006		32		04		01		05		01		036008	
C46088		HEAT		20		110		008		004		23		04		02		06		01		039007	
C46088		HEAT		20		111		008		008		34		04		02		06		01		042006	
U41444		HEAT		20		108		008		007		35		03		01		04		02		035007	
U41444		HEAT		20		109		006		008		25		03		01		04		02		034008	
U41444		HEAT		20		111		007		008		25		03		01		04		02		034008	
						**		END OF DATA THIS		*****		**											

\*C.F. IS BASED ON THE FOLLOWING EQUATION: C.F. = C + MN/6 + (CN-MN-V)/5 + (CU+X)/15 = 0.43

DECIMAL POSITIONS FOR ELEMENTS ARE INDICATED BY THE LEFT MARGIN, VERTICAL DOTTED LINE OR DECIMAL POINT. ELEMENTS REPORTED IN MASS FRACTION (%)  
S17901004 TQ454832 S162440122 0-0-0 PAGE 1 OF 2

REVISIONS



Nol-X NDT Service  
Company NTUA  
PQR No. NO1BR-P  
Date 12-6-12  
By [Signature]



UNITED STATES STEEL

TUBULAR PRODUCTS  
CERTIFIED TEST REPORT  
IN ACCORDANCE WITH ISO 10474/EN12068/ISO9001 (Type 3.1)

DATE: 06/07/12  
TIME: 13:57:55  
SERIAL NO: F0074634

BILL OF MATERIALS NO. DR04462 08		SHEET NO. Y22767		P.O. NUMBER 87ND042937D													
MATERIAL SPEC. AS-ROLLED		GR. S. 625 (210,075)		WALL THICKNESS 0.322 (8.178)													
PRODUCT IDENTIFICATION	FLAY	END	ORAN SIZE	MM COLIFORM	DIR	TRAY LOC	TEMP	RND	TEST COND.	CHARPY IMPACT TESTING				% DEAR			
										FT LBS		J		%		%	
C46068	OK				T	B	+ 32	2/3	AR	23	22	24	23	10	10	10	10
C46068					T	B	+ 32	2/3	AR	24	25	21	23	10	10	10	10
U61444	OK				T	B	+ 33	2/3	AR	24	25	21	23	10	10	10	10
U61444					T	B	+ 32	2/3	AR	25	23	22	23	10	10	10	10
** END OF DATA THIS SHEET **																	
LOCUS		L - LONGITUDINAL		T - TRANSVERSE		S - BODY		W - WELD		HAZ - HEAVY AFFECTED ZONE							
TEST / INSPECTION INFORMATION																	
TEST / INSPECTION INFORMATION																	
RESULTS / COMMENTS																	
FULL LENGTH VISUAL <input checked="" type="checkbox"/>																	
FULL LENGTH RM <input checked="" type="checkbox"/> DD _____ ODND _____ X L _____ UT _____ X 10.0/10.0% NOTCH																	
FULL LENGTH MH _____ ID _____ ODND _____ L _____ UT _____																	
FULL LENGTH UT _____ MPI _____ X _____ UT _____																	
END AREA INSPECTION (PLAIN END) <input checked="" type="checkbox"/> MPI _____ UT _____																	
SPECIAL END AREA (SEAM END) _____ MPI _____ UT _____																	
FULL LENGTH DRIFT _____ DRIFT MANDREL SIZE _____																	
ADDITIONAL NOTES/COMMENTS																	
ALL MELTING AND MANUFACTURING TOOK PLACE IN THE USA. MANUFACTURED IN AN ISO 9001 CERTIFIED FACILITY - CERTIFICATE #30727. NO REPAIRS BY WELDING. NO MERCURY OR MERCURY COMPOUNDS ARE ADDED TO THE STEEL AND ALL MERCURY BRAKING EQUIPMENT IS PROTECTED BY A DOUBLE BOUNDARY OF CONTAINMENT. *NOTE A SEE ATTACHED REPORT FOR TENSILE RESULTS. *NOTE B SEE ATTACHED REPORT FOR TENSILE RESULTS. ** END OF DATA **																	

THIS IS TO CERTIFY THAT THE PRODUCT DESCRIBED HEREIN WAS MANUFACTURED,  
SAMPLED, TESTED AND/OR INSPECTED IN ACCORDANCE WITH THE SPECIFICATION  
AND FULFILLS THE REQUIREMENTS IN SUCH RESPECTS.

PREPARED BY THE OFFICE OF: J. MAJORSKAK - MANAGER, Q.A.

DATE: 06/07/12

517901004

TQ456032

5362440122

0-0-0

PAGE 2 OF 2

Not-X NDT Service

Company NTUA  
QR No. NDIBR-P  
Date 12-6-13  
[Signature]



UNITED STATES STEEL

TUBULAR PRODUCTS  
TENSILE TEST REPORT

DATE: 05/07/12  
TIME: 13:58:04  
PAGE: 1

MILL ORDER NUMBER <b>DRC4462 06</b>	ENGINEER NO. <b>Y22767</b>	P.O. NUMBER <b>87N0429370</b>	HEAT	SERIAL NUMBER: <b>F0074434</b>
BILL TO ADDRESS <b>MCGUNKIN RED MAN CORP PO BOX 513 HOUSTON TEXAS 75068 CHARLESTON WV 25322-0513</b>		MAIL TO ADDRESS		VENUE <b>USS TUBULAR PRODUCTS 655 FAIRFIELD MOBILE P.O. BOX 999 FAIRFIELD ALABAMA 36504</b>

HEAT	PIPE/ LOT	TYPE/ DIM/ LOC	TEST COND	YIELD	ELONG	TENSILE	Y/T	ELONG % AREA
✓ C46068	7804	STRIP/L/D	AR	54,800	0.50	79,500	0.69	49.2
C46068	7796	STRIP/L/D	AR	52,800	0.50	79,000	0.66	39.2
✓ C46068	7795	STRIP/L/D	AR	47,900	0.50	77,500	0.62	40.0
U41444	7801	STRIP/L/R	AR	51,000	0.50	77,000	0.66	42.0
U41444	7807	STRIP/L/R	AR	48,000	0.50	77,000	0.62	39.9

lol-X NDT Service

Company NTUA  
 QR No. ND1BR-P  
 Date 12-10-13  
 by [Signature]



# Welding & Joining Management Group

FORENSIC EXPERTS • METALS TESTING

## Vickers Micro-Hardness Report

Client:	NOL-X NDT Service	George Noland	NOIBR-P	Date:	12/16/2013
WJMG #:	2013458-1	API 1104 X42	NACE MR0175 / ISO 15156	Technician:	Jesse Grantham
Specimen #:	2013356-1 NOIBR-P	Butt Weld	Circumferential	10 Kilograms	Ronny Stanley

Base Metal									
BM 1			661.0	661.0	661.0	0.489	323.2290	0.3232	177.4936
BM 2			667.0	667.0	667.0	0.489	326.1630	0.3262	174.3147
BM 3			663.0	663.0	663.0	0.489	324.2070	0.3242	176.4244
BM 4			667.0	667.0	667.0	0.489	326.1630	0.3262	174.3147
BM 5			664.0	664.0	664.0	0.489	324.6960	0.3247	175.8934
					0.0	0.489	0.0000	0.0000	#DIV/0!
					0.0	0.489	0.0000	0.0000	#DIV/0!
					0.0	0.489	0.0000	0.0000	#DIV/0!
HAZ									
HAZ 1			580.0	580.0	580.0	0.489	283.6200	0.2836	230.5312
HAZ 2			571.0	571.0	571.0	0.489	279.2190	0.2792	237.8557
HAZ 3			583.0	583.0	583.0	0.489	285.0870	0.2851	228.1648
HAZ 4			569.0	569.0	569.0	0.489	278.2410	0.2782	239.5307
HAZ 5			588.0	588.0	588.0	0.489	287.5320	0.2875	224.3009
					0.0	0.489	0.0000	0.0000	
Weld									
Weld 1			651.0	651.0	651.0	0.489	318.3390	0.3183	182.9885
Weld 2			654.0	654.0	654.0	0.489	319.8060	0.3198	181.3135
Weld 3			655.0	655.0	655.0	0.489	320.2950	0.3203	180.7603
Weld 4			655.0	655.0	655.0	0.489	320.2950	0.3203	180.7603
Weld 5			650.0	650.0	650.0	0.489	317.8500	0.3179	183.5519
					0.0	0.489	0.0000	0.0000	#DIV/0!
					0.0	0.489	0.0000	0.0000	#DIV/0!
					0.0	0.489	0.0000	0.0000	#DIV/0!
Comments: HV = 1.8544 P, kg D <sup>2</sup> mm									

FR 6-4-1A Vickers Micro Hardness

Nol-X NDT Service

Company NTUA  
 PQR No. NOIBR-P  
 Date 12-4-13  
 By [Signature]

3756 Monarch Street • Frederick, Colorado 80516 • www.WJMG.com  
 OFFICE: 303-451-8759 • FAX: 303-280-4747 • TOLL-FREE: 800-987-9269





# Welding & Joining Management Group

FORENSIC EXPERTS • METALS TESTING

12/16/13  
NOL-X NDT, WJMG 2013458

## Hardness Survey Typical Indent Locations

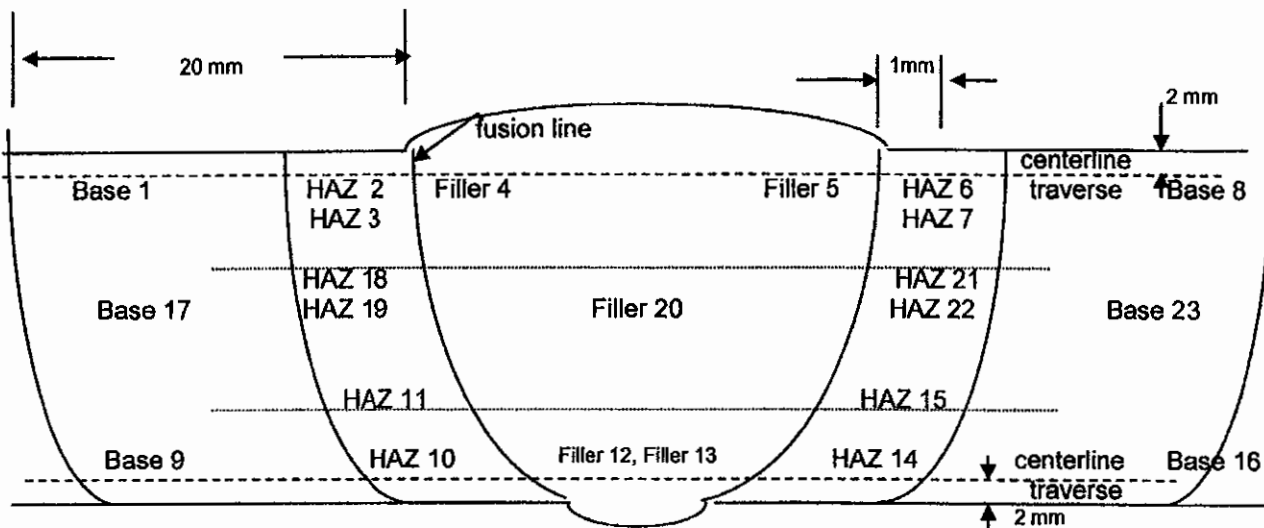

HAZ indents are made in the coarse grain portion of the HAZ

### NOTES:

1. Indents @ 20 mm from fusion line represent unaffected base metal.
2. Hardness survey specimens are prepared and tested in accordance with ASTM E92 or ASTM E384 using an applied load of
3. Heat Affected Zone (HAZ) readings taken in vertical region of HAZ centerline

Nol-X NDT Service

Company *NTL-A*

PQR No. *ND1BR-P*

Date *12-6-13*

By *A. C. [Signature]*

Company NMA  
 PQR No. ND1BR-P  
 Date 12-6-13  
 By [Signature]

FARMINGTON BRIGHTON Grand Junction ANCHORAGE CASF

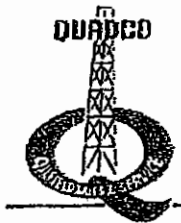

Serving the Rocky Mountain Area

Farmington Office • PHONE: (505) 327-0486 • 1390 E. Murray Dr. • Farmington, NM 87401 •  
 www.quadcoinc.com

## CALIBRATION TEST REPORT

TEST REPORT #: \_\_\_\_\_ REPAIR ORDER#: 10011693.  
 CUSTOMER: NOL-X PHONE: 720-2,182.  
 ADDRESS: \_\_\_\_\_ FAX: \_\_\_\_\_  
 CITY: FARMINGTON STATE: NM.  
 CUSTOMER CONTACT: GEORGE.

SYSTEM: CRC EVANS. CAPACITY: 15000 SER.#: CRC418.

LOAD APPLIED (psi)	AS FOUND (psi)	AS LEFT (psi)
25% <u>3750</u>	<u>3750</u>	<u>3750</u>
50% <u>7500</u>	<u>7500</u>	<u>7500</u>
75% <u>11250</u>	<u>11250</u>	<u>11250</u>
100% <u>15000</u>	<u>15000</u>	<u>15000</u>

ROOM TEMP: 70 deg F. TEST DATE: 7/12/13. TEST BY: [Signature]  
 CHECKED BY: [Signature] INSIDE CHECK: [Signature]

TEST EQUIPMENT: DWT MLISK-1 S/N: 0117 / MLISK-1

THIS INSTRUMENT HAS BEEN CALIBRATED WITH A PRESSURE STANDARD WHOSE ACCURACY IS TRACEABLE TO THE N.I.S.T. TEST NUMBERS.

MODEL: RS DWT 2-1 S/N: 5212

TEST NUMBERS: P-8365 P-8109 P-8085

RECOMMENDED CALIBRATION:

APPROVED BY: CHRIS DOYLE  
 Signature

Printed Name  
 WITNESSED BY: STEVE VITZY  
 Signature

NOL-X NDT SERVICE  
105 Parkland Circle  
Farmington, NM 87401

660A TRMS Amperage & Voltage Clamp Meter (#61-765)

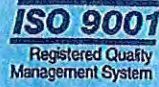

### Certificate of Conformance

IDEAL INDUSTRIES, INC. hereby certifies that this product was checked and/or calibrated in accordance with applicable calibration practices using equipment that is calibrated to standards traceable to the National Institute for Standards and Technology (NIST). These procedures are ISO-9001 controlled and are designed to assure that the instrument meets its published specifications.

This meter is warranted to the original purchaser against defects in material or workmanship for the period stated in the instruction manual, excepting normal wear and abuse.

Serial Number

SERIAL NO: 120900333

IDEAL INDUSTRIES, INC.  
Becker Place  
Sycamore, IL 60178, U.S.A.  
877-201-9005 Technical Hotline  
www.testersandmeters.com  
ND 2435-2

In-service Date 07-11-2013  
Calibration Due Date 07-11-2014

By G C Noland

Nol-X NDT Service

Company NTUA  
PQR No. NDIBR-P  
Date 12-6-13

By G C Noland

**NOL-X NDT SERVICE**

105 Parkland Circle  
Farmington, NM 87401

Infrared (IR) Thermometer (#61-685)

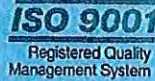

**Certificate of Conformance**

IDEAL INDUSTRIES, INC. hereby certifies that this product was checked and/or calibrated in accordance with applicable calibration practices using equipment that is calibrated to standards traceable to the National Institute for Standards and Technology (NIST). These procedures are ISO-9001 controlled and are designed to assure that the instrument meets its published specifications.

This meter is warranted to the original purchaser against defects in material or workmanship for the period stated in the instruction manual, excepting normal wear and abuse.

Serial Number  
SN: E0082003215

IDEAL INDUSTRIES, INC.  
Becker Place  
Sycamore, IL 60178, U.S.A.  
877-201-9005 Technical Hotline  
www.testersandmeters.com  
ND 2435-2

In-service Date 07-11-2013  
Calibration Due Date 07-11-2014

By G C Noland

Nol-X NDT Service

Company NTUA  
PQR No. NO1BR-1  
Date 12-6-13

By