

**Request for Proposals**  
**Re-Bid Number: 21-11-2609LE**

The Navajo Nation Office of the Controller - Purchasing Department, and Navajo Division of Transportation - Department of Roads, are accepting qualifications and sealed bids for route N5066-Aneth, UT: subgrade prep, road reconditioning, 24-ft wide full depth reclamation, adding crushed aggregate if required, double coarse chip seal, fog seal, drainage improvements (includes maintenance of furrow ditches & culvert cleaning at 2 locations), and permanent signage. Project length is approximately 2.0 miles.

Contacts for a bid packet are L. Etsitty, Navajo Nation Purchasing Department, [www.nnooc.org](http://www.nnooc.org), (928) 871- 6317; or, D. Jackson, Navajo DOT, Department of Roads, [djackson@navajodot.org](mailto:djackson@navajodot.org), (505)371-8350.

The closing date for this project is January 25, 2022, at 2:00pm, Window Rock, AZ, time. Any RFPs received after the closing date will be considered non-responsive and returned to the sender. No facsimile or emailed RFPs will be accepted.

**INTENTIONALLY LEFT BLANK**

## **Section 1 - Overview**

1. Request for Proposal (RFP) Packet – The instructions on the proposal preparation, required documents, eligibility requirements, and evaluation criteria are provided herein.

The RFP package may be obtained from the Navajo Division of Transportation website, beginning January 13 - <http://www.navajodot.org/RFP.aspx>. The Proposal Packet can also be obtained from the Navajo Nation Purchasing Department, [www.nnooc.org](http://www.nnooc.org), or, D. Jackson, Navajo DOT, [djackson@navajodot.org](mailto:djackson@navajodot.org), (505)371-8350.

Note: If a firm download's from the websites given above or gets a copy of the RFP from another source other than from Mr. Jackson, please contact Mr. Jackson by email so that if an addendum(s) or questions are issued/answered, your firm will receive the information.

2. This maintenances project includes the following challenges:

- There is no bid item for water; the contractor is expected to incorporate this cost into the maintenance activities requiring water.

General Scope of Work (SOW) – 6-inch subgrade prep, road reconditioning, 24-ft wide full depth reclamation, adding crushed aggregate if required, 22-ft wide double coarse chip seal, fog seal, drainage improvements (includes maintenance of furrow ditches & culvert cleaning at 2 locations), and permanent signage. Project length is approximately 2.0 miles. Furthermore, the subgrade, AB course, and surface course will be treated as per the typical cross-sections in the SOW. Ground disturbance will be intensive and extensive. The Navajo Nation is the lead agency and is using Navajo Nation Road funds for the project.

**Note: The Contractor selected for this project is tentatively not expected to start maintenance activities until the Spring or Summer of 2022. No change order(s), regardless of the NTP date, will be entertained for price increases to complete this maintenance project. The Contractor's initial bid amount is what the Owner shall consider FIRM and non-negotiable.**

3. Schedule of Activities: Note, all times are Window Rock, AZ, 2022, times.

<u>Activities:</u>	<u>Due Date:</u>
i. Advertised Period	January 13-22, 2022.
ii. Deadline to Submit RFP Questions	January 23.
iii. Final Response to Written RFP Questions	January 24, by 12:00pm.
iv. RFP Submittal Deadline	January 25, by 2:00pm.
v. Evaluation of proposals	January 26.
vi. Final Selection of Firm	January 27.

4. Inquiries – Questions regarding this RFP must be submitted by email to the Project Contact listed below. Written questions as to the intent or clarity of this RFP can be submitted to the Project Contact until January 23. Written responses to written questions and any RFP amendments will be distributed by email to all parties who obtained an RFP package and have notified L. Etsitty, NN Purchasing Department, or D. Jackson, Navajo DOT. No further questions, in any form, will be entertained after the January 23 deadline. Project Contact: D. Jackson, Engineer, Navajo Division of Transportation, Telephone: (505) 371-8350, and Email: [djackson@navajodot.org](mailto:djackson@navajodot.org).

5. Proposal Submittal Deadline – Proposals must be physically submitted to the following address by January 25, no later than 2:00 PM (local Window Rock, AZ time).



Navajo Division of Transportation  
Attention: Don Jackson  
Navajo Transportation Complex  
#16 Old Coal Mine Road  
Mentmore, NM 87319

**Late, facsimiled or e-mailed proposals will not be accepted. These will be returned to the firm un-rated and firms responding in such fashion shall be considered non-responsive.**

6. Addendum to the RFP – In the event it becomes necessary to revise any part of the RFP, Navajo DOT shall issue a written addendum on the specifics of the change and inform all concerned. **Addendums will also be made available for download from the Navajo DOT website ([www.navajodot.org](http://www.navajodot.org)).** The addendum(s) does not need to be included as part of the RFP document. However, the consulting firm should acknowledge receipt and review of the addendum(s) under the Letter of Interest.

7. Rejections of Proposals – The Navajo DOT reserves the right to reject any or all proposals and to waive informalities in the proposals received whenever such a rejection or waiver is in the best interest of the Navajo nation.

8. Proprietary Information – Any restrictions on the use of data contained within any proposals must be clearly stated in the proposal. Each page that contains proprietary information must be stamped or imprinted “Proprietary”.

9. Ownership of Proposals – All materials submitted with the RFP accepted for rating shall become the property of Navajo DOT and not returned to the firm. The Navajo DOT has the right to use any or all information presented in the RFP subject to limitations outlined in Paragraph 8, above. Disqualifications or non-selection of a firm or proposal does not eliminate this right.

10. Cost Incurred – The Navajo DOT is not liable for any cost incurred by the firm prior to issuance of a signed contract for services.

11. Contractual Obligation – The contents of the proposal may become part of contractual obligations of the contract award. Failure of the firm to accept these obligations may result in cancellation of the award for services.

12. Evaluation Criteria – Proposals accepted for rating shall be evaluated based on the criteria and point system set forth in Part 12(a) that follows.

Part 12(a) – Rating System on Evaluation Criteria

Each proposal will be evaluated and rated as follows. Descriptions of the components are provided in Section 3 – Proposal Content and Evaluation Criteria

- |  |           |
|--|-----------|
| 1. Overall professionalism and conciseness of proposal.....  | 15 points |
| 2. Qualifications & Experience, of firm & project team.....  | 30 Points |
| 3. Approach to Scope of Work, including FP-14 Specifications, and to include Project Understanding & Project Scheduling. | 40 Points |
| 4. Listing of Equipment for SOW; and Product Certifications as Stated in Specifications.                                 | 15 Points |

---

Total Points	100 Points
--------------	------------

A Short List of qualified candidates will be determined from the 100 points. To get to the Short List, the firms must receive a minimum of 80 points.

Preference Points: If a Priority 1 firm makes the Short List, that firm will receive an additional ten (10) points added to their score ranking. If a Priority 2 firm makes the Short List, that firm will receive an additional five (5) points added to their score ranking. Non-priority firms do not receive additional points. This is a requirement from the Navajo Nation Business Opportunity Act. Firm must provide documentation per the Business Regulatory Department as prioritized under Section 204 (A) (1) and (2) of the revised Navajo Nation Business Opportunity Act, of its Priority 1 or 2 status.

It is intent of Navajo DOT to rank the firms according to the responses submitted. The Navajo DOT reserves the right to conduct detailed interviews in person, of qualified/responsive firms, if warranted.

13. Standard Contract – The Navajo Nation reserves the right to incorporate contract provisions which are based on applicable requirements, such as, Navajo Nation Laws, State, and local requirements, etc. into the contract documents. This includes provisions of the Navajo Business and Procurement Act, at 12 N. N. C. § 1501 et Seq., and the Navajo Business Opportunity Act, at 5 N. N. C. § 201 et Seq.

14. Taxes – All work performed, and services provided within the territorial jurisdiction of the Navajo Nation is subject to the six percent (6 %) Navajo Sales Tax (24 N. N. C. § 601 et Seq.).

15. Insurance – The Navajo Nation will require the successful firm, at its sole expense, to procure and maintain adequate and sufficient insurance for all potential liability, such as, commercial general liability, automobile liability, worker’s compensation, performance & payment bonds, etc. The general contractor shall provide all bonds and insurance prior to the Notice to Proceed with Construction. For the Proposal, provide affidavit from surety indicating Contractor’s ability to provide said bonds.

16. Bonding documentation required. The Navajo Nation’s Representative must receive written documentation of all required bonds prior to the issuance of a Notice to Proceed for the Project, and Contractor shall not commence any work or services under this Contract until such documentation is received by the Navajo Nation.

17. Disclaimer – The Navajo Nation’s acceptance or review of any proposal shall not guarantee the execution of any contract, and the proposed contract shall be reviewed by all appropriate departments through the 2 N. N. C. § 164 review process, including the Navajo Nation Department of Justice, for administrative and legal sufficiency, prior to execution by the Navajo Nation. The Navajo Nation reserves the right to reject any proposed contract prior to execution, for improprieties in the procurement process or applicable Navajo Nation or federal laws or regulations, or the failure to submit all requested documents or information.

## **Section 2 – Proposal Requirements and Selection**

### 1. Proposal Submission

- A. Proposal must be submitted in a sealed envelope clearly marked:
  - a. **“DO NOT OPEN – RFP for Re-Bid #21-11-2609LE, N5066-Aneth;** 6-inch subgrade prep, road reconditioning, 24-ft wide full depth reclamation, adding crushed aggregate if required, 22-ft wide double coarse chip seal, fog seal, drainage improvements (includes maintenance of furrow ditches & culvert cleaning at 2 locations), and permanent signage. Project length is approximately 2.0 miles.
  - b. The name of the firm submitting the proposal shall be legibly written and shown on the outside of the sealed envelope, to include the firms address.
- B. Proposal Standards: The firm shall submit one (1) original and three (3) identical copies of their RFP packet for the evaluation committee members. Appearance of proposal is important and professionalism in proposal presentation should not be neglected. The proposal standards are as follows:
  - a. This RFP proposal may not exceed 15 single-sided pages (maximum 8 ½” x 11”) with a minimum of 10 pt. type.
  - b. Pages that have photos, charts, and graphs will be counted towards the maximum number of pages.
  - c. The following information is not included in the 15-page limit: proposal front and back cover; cover letter on company letterhead; divider and/or tabs, as long as there is nothing on them; and maximum 1-page resumes of each team member.
  - d. RFP submittals should be plastic or metal spiral-bound only. **Please do not submit RFP in loose-leaf 3-ring binders; these will be considered non-responsive and returned to the firm un-rated.**
  - e. Submissions exceeding the 15-page limit or any resumes exceeding the 1-page limit will be considered non-responsive and will be returned to the Applicant un-rated.
- C. In a separate sealed envelope clearly marked as **“BID PROPOSAL – N5066-Aneth; Re-Bid #21-11-2609LE,** the firm shall provide its bid amount to complete the Scope of Work. The sealed envelope will not be opened by the Navajo DOT until after the RFP proposals have been reviewed and ranked.

2. Proposal Review Process, Receipt of proposals, will be verified on the due date specified. The Navajo DOT will screen and evaluate proposals received in accordance with the following criteria. Proposals which fail this check will be considered non-responsive and returned to the firm un-rated.

- a. Proposal is received by the required deadline date and time.

- b. Proposal meets the proposal submission requirement set forth above, under Section 2, Part 1, (A), (B), & (C).
3. Proposal Evaluation
    - a. Proposal shall be evaluated and rated in accordance with the criteria outlined in Part 12(a) - Rating System on Evaluation Criteria.
    - b. The Navajo DOT will rate the proposal based on total points awarded and all firms with a minimum score of 80 out of 100 points will be determined as responsive. The Navajo DOT reserves the right to interview these qualified firms.
  4. Award of Contract
    - a. The Navajo DOT will issue a Notice to Proceed to the firm upon execution of the contract. No work shall be performed by the firm until such notice is given by Navajo DOT. The Navajo DOT is not liable for any cost incurred by the firm prior to issuance of a signed contract award, for “6-inch subgrade prep, road reconditioning, 24-ft wide full depth reclamation, adding crushed aggregate if required, 22-ft wide double coarse chip seal, fog seal, drainage improvements (includes maintenance of furrow ditches & culvert cleaning at 2 locations), and permanent signage. Project length is approximately 2.0 miles”. Note: refer to typical drawing attached to RFP for roadway dimensions.

### **Section 3 – Proposal Content and Evaluation Criteria**

1. Qualifications and Experience of firm and project team. Proposals must specifically address and affirm the following:
  - a. Letter of Interest that indicates why your firm should be selected for project N5066-Aneth. In addition, firm should acknowledge receipt and review of any addendum(s) issued. State that firm is capable to perform all or most aspects of the project.
  - b. Evidence of insurance and statement from bonding company that all bonds will be completed prior to Notice to Proceed with Construction.
  - c. Resume of personnel that will be involved in the task of completing projects, including professional qualifications and experiences of key personnel. Include personnel of sub-consultants which will be utilized by the prime consultant.
  - d. Provide key personnel’s availability for the proposed work, and roles and responsibilities. Include their knowledge of the Navajo Nation, and FP-14 Specifications with respect to 6-inch subgrade prep, road reconditioning, 24-ft wide full depth reclamation, adding crushed aggregate if required, 22-ft wide double coarse chip seal, fog seal, drainage improvements (includes maintenance of furrow ditches & culvert cleaning at 2 locations), and permanent signage. Project length is approximately 2.0 miles.
  - e. Organizational Chart outlining the inter-relationship and line of communication between the firm and sub-consultants.
  - f. Recent experiences in providing services comparable to the proposed SOW as listed in Section 4. Interested firms shall provide three (3) references from similar projects within the last five (5) years. List the reference’s contact person’s name, address, and phone number.



2. Approach to Scope of Work with respect to FP -14 Specifications.
  - a. Approach to Scope of Work - Describe your understanding of the project and approach to delivering the project SOW with respect to FP -14 Specifications, in addition to the work described in Section 4.
  - b. Include how your firm will schedule the work. Include a graphical illustration i.e., a Project Schedule such as a GANTT Chart.
3. List of Equipment for SOW and Product Certifications, as Stated in Specifications.
  - a. List equipment to complete the Scope of Work and list Product Certifications, including meeting requirements as stated in FP-14 Specifications.

**Section 4** – SCOPE OF WORK for Project N5066-Aneth, UT: 6-inch subgrade prep, road reconditioning, 24-ft wide full depth reclamation (10-inch depth), adding crushed aggregate if required, 22-ft wide double coarse chip seal, fog seal, drainage improvements (includes maintenance of furrow ditches & culvert cleaning at 2 locations), and permanent signage. Project length is approximately 2.0 miles. While only the FP-14 Specifications for the Bid Items are attached to this RFP, the entire ‘*Standard Specifications for Construction of Roads and Bridges on Federal Highway Projects FP-14*’, applies to this project. Contractor is advised to read attached specifications which references other specifications within FP-14.

This maintenance project includes the following challenges:

- *Note: The Contractor selected for this project is not expected to start maintenance activities until the Spring or Summer of 2022. No change order(s), regardless of the NTP date, will be entertained for price increases to complete this maintenance project. The Contractor’s initial bid amount is what the Owner shall consider FIRM and non-negotiable.*
- There is no bid item for water; the contractor is expected to incorporate this cost into the maintenance activities requiring water.
- In the event of a shutdown of any and/or all Road Fund maintenance projects ordered by Navajo Nation President Jonathan Nez, due to the coronavirus, no compensation/payments for rental equipment remaining idle during this Stop Work Order will be honored by the Navajo Nation. Furthermore, prior to the Contractor beginning any work at the project site, an updated Safety & Health Plan shall be submitted to the Project CM. The plan shall address how the Contractor will protect the general public, its workers, and first responders & their families from the coronavirus.

FP-14 can be downloaded from the following website: <https://flh.fhwa.dot.gov/resources/specs/fp-14/fp14.pdf>.

When construction begins, coordination with Navajo DOT shall be through the Construction Manager (CM), Don Jackson (505-371-8350), [djackson@navajodot.org](mailto:djackson@navajodot.org).

**Additional Scope of Work requirements:**

1. BOP: 37°15'44.99"N, 109°12'1.37"W. EOP: 37°17'04.04"N, 109°10'46.42"W.
2. Water is not a bid item. The Contractor selected for this project shall include the cost of water to perform all maintenance activities to specifications in the appropriate bid item. This includes dust abatement.

3. It is the responsibility of the Firm/Contractor selected for this project to contact, Navajo DOT – Project Management Department, immediately after the contract for this project is fully executed. Project Management oversees all environmental, biological, and archeological compliances required by all government agencies. Contractor will request from Project Management all requirements needed to comply with all environmental & archeological conditions for this project. Written documentation shall be the required mode of communication regarding this requirement. The Construction Manager shall be notified within 24-hrs regarding communication between the Contractor, Project Management, and other compliance agencies; these communications shall be in written form.
4. Section 107 - LEGAL RELATIONS AND RESPONSIBILITY TO THE PUBLIC: Follow the requirements of FAR Clause 52.236-7 Permits and Responsibilities. Comply with applicable laws, ordinances, safety codes, regulations, orders, and decrees. Protect and indemnify the Government and its representatives against claim or liability arising from or based on the alleged violation of the same. Comply with permits and agreements obtained by the Government for performing the work that is included in the contract. Obtain additional permits or agreements and modifications to Government obtained permits or agreements that are required by the Contractor's methods of operation. Submit copies of permits and agreements.
5. Mobilization - Section 151: This work consists of moving personnel, equipment, material, and incidentals to the project and performing work necessary before beginning work at the project site. This work also includes obtaining permits, insurance, and bonds.
6. Section 152. — CONSTRUCTION SURVEY AND STAKING:
  - a. Establish centerline, ditch line, and other points to establish proposed road profile as shown on Typical Sections(s).
7. Section 153 - CONTRACTOR QUALITY CONTROL. Payment is in Bid Schedule as Bid Item #3.
8. Section 154 - CONTRACTOR SAMPLING AND TESTING. Payment is in Bid Schedule as Bid Item #3.
  - a. This work consists of obtaining samples for testing and reporting required test results at least seven (7) calendar days before work begins. This includes all Section 204, 303, 311, and 633 work, to include geotechnical samples prior to subgrade preparation, finished subgrade, prior to stabilization activities, and after completion of Aggregate Base Course & Reclamation activities.
  - b. Supplement to Section 154: Allow the Construction Manager and/or Engineer staff the opportunity to witness all testing. Testing of trial samples may be required to demonstrate testing competence.
9. Section 155 - SCHEDULES FOR CONSTRUCTION CONTRACTS. Submit construction schedule per Section 155.
  - a. Supplement to Section 155: 155.01 Description. The second sentence is deleted.
  - b. Critical Path Method construction schedules are not allowed.
10. Controlling and protecting public traffic and dust abatement (for the work and public travel) is not a pay item. For instruction regarding these activities, refer to FP-14 and Section 156 – PUBLIC TRAFFIC.
11. Section 204. — EXCAVATION AND EMBANKMENT. Refer to Section 204 for Furrow Ditches. For topsoil, refer to this section and Section 303, also.



12. Section 303 - ROAD RECONDITIONING. Road Conditioning shall be completed per FP-14 Section 303.07. This work consists of reconditioning ditches, shoulders, roadbeds, aggregate base course, aggregate stabilization, and miscellaneous construction i.e., the entire road. Note: To complete Road Conditioning per Roadway Typical, fill material required will be obtained from either end of edge of road.
  - a. ABC Testing Report and Certificate of Compliance shall be submitted for approval two weeks prior to placement.
  - b. Prior to work, Contractor will select according to FP-14 specifications a qualified geotechnical firm. This firm will aid contractor in determining maximum dry unit weight (Proctor), through sieve analysis the appropriate compaction equipment to be used, and other pertinent testing. Contractor will give results of geotechnical testing to the CM for approval of Contractor's compaction method and choice of compaction equipment.
  - c. No work will be performed within rivers, channels, streams, or Waters of the US prior to required Navajo Nation and Federal Government permits/certifications. However, Ditch Reconditioning per Section 303.03 of FP-14 is still a project requirement throughout the 2.0-mile project.
  - d. Grade to drain at all furrow ditches and culvert locations.
13. Section 304. — FULL DEPTH RECLAMATION
  - a. 10-inch depth at 24-width.
  - b. Crushed aggregate is according to Section 703.06 of FP-14.
14. Section 406. — FOG SEAL: 25,825 SY @ 22-ft width.
15. Section 407. - CHIP SEAL: Double Coarse.
  - a. For Double Course, Type 2A or 2B; 28,825 SY.
  - b. No material pay factor for chip seal work.
16. Section 607. —CLEANING, RELAYING, AND REPAIRING EXISTING DRAINAGE STRUCTURES
  - a. 2-culverts.
  - b. Construction requirements: Sections 607.02 through 607.04.
17. Section 633. — PERMANENT TRAFFIC CONTROL: For permanent traffic control provide & install the following signage quantities:
  - a. 2-30 mph, Type R2-1, 18"x24".

- b. The contractor shall install a Type A delineator and foundation for damaged delineators at all culvert locations (as directed by the Construction Manager), 4-each at every culvert location.
  - c. Two permanent special signs which notify graders to not blade within project area.
  - d. 1 BIA-DOT, Navajo Area, "N5066" sign. Consult BIA-DOT for sign specifications.
  - e. All signs conform to latest version of MUTCD.
  - f. Furnish hardware for all signs, per Section 633.02 of FP14.
  - g. All panels for signs per Section 633.02 of FP14.
  - h. All posts of galvanized type, per Section 633.02 of FP14.
  - i. Further miscellaneous materials for signage per Section 633.02 of FP14.
18. Section 634. — PERMANENT PAVEMENT MARKINGS
- a. Type B – Waterborne traffic paint with Type 1 glass beads. 4-inch solid double yellow.
19. Section 635 - TEMPORARY TRAFFIC CONTROL: In addition to following Section 635, Contractor is to abide by the following.
- a. At least one lane will always remain opened, and motorist will always have access.
  - b. Traffic Control Plan (TCP) will be submitted to Contract Manager for approval 10-business days prior to any work on N112. Any changes to TCP during construction will require Contractor to submit updated plan to CM 5-days minimum for approval.
20. Submittals - In addition to submittals for Bid Items, other submittals required are the following: All submittals are considered part of Bid Items.
- a. Certifications for materials, per FP-14 specifications.
  - b. Safety & Health Plan per FP-14 specifications.
  - c. Contact list of any sub-contractors and key personnel.
  - d. SWPPP & BMPs, per FP-14 specifications.
21. Water: There will be no separate bid item for water and the water permit. The cost for providing water shall be included in the respective bid items for the work to be performed.
22. The vendor will have to dispose of any rejected material at his own expense off the Government property in approved recycle facilities.
23. Provide an estimated timeline bar chart schedule for this project.
24. Explain approach for other activities required for acceptable Scope of Work and compliance with specifications.
25. State how project communication is intended to keep all parties involved in the project.
26. Materials Delivery Contractor shall follow their Temporary Traffic Control and Safety Plan, as well as Navajo DOT's traffic control plan throughout the construction of the project.
27. Staging area is a Mobilization item.

**CERTIFIED NAVAJO BUSINESS:** If applicable, provide documentation that the business is currently certified by the Navajo Nation Business Regulatory Department and prioritized under Navajo Nation Council Resolution CAP-37-02 and, also, under the Section 204 (A) (1) and (2) of the revised Navajo Nation Business Opportunity Act.

If selected for this project, submit to Navajo DOT the following:

- **PROOF OF CERTIFICATE OF INSURANCE:** Provide proof of Certificate of Insurance.
- Taxpayer Identification: Form W-9.
- Affidavit of Non-Collusion.

**Quality Assurance:**

Navajo DOT will provide quality assurance to ensure that work is being performed in accordance with the Scope of Work and project specifications.

Final inspection will include Navajo DOT for acceptance of scope of work.

**Compliance:**

Comply with conditions stated in all compliance reports, cultural & biological. If cultural site is discovered, immediately notify NDOT Project Management & Roads Dept. Note: Navajo DOT will give copies of archeological & environmental reports to selected Contractor. Contractor will notify Navajo DOT – Project Management Department of its selection as the General Contractor.

Contractor and his sub-contractors will stay in “footprint” of existing road. Written request by Contractor to Project Management to go out of existing “footprint” is required.





# FY 2019 & FY 2020 Road Fund - Northern Agency N5066 - Aneth, UT

109°15'0"W 109°14'30"W 109°14'0"W 109°13'30"W 109°13'0"W 109°12'30"W 109°12'0"W 109°11'30"W 109°11'0"W 109°10'30"W 109°10'0"W 109°9'30"W 109°9'0"W 109°8'30"W 109°8'0"W

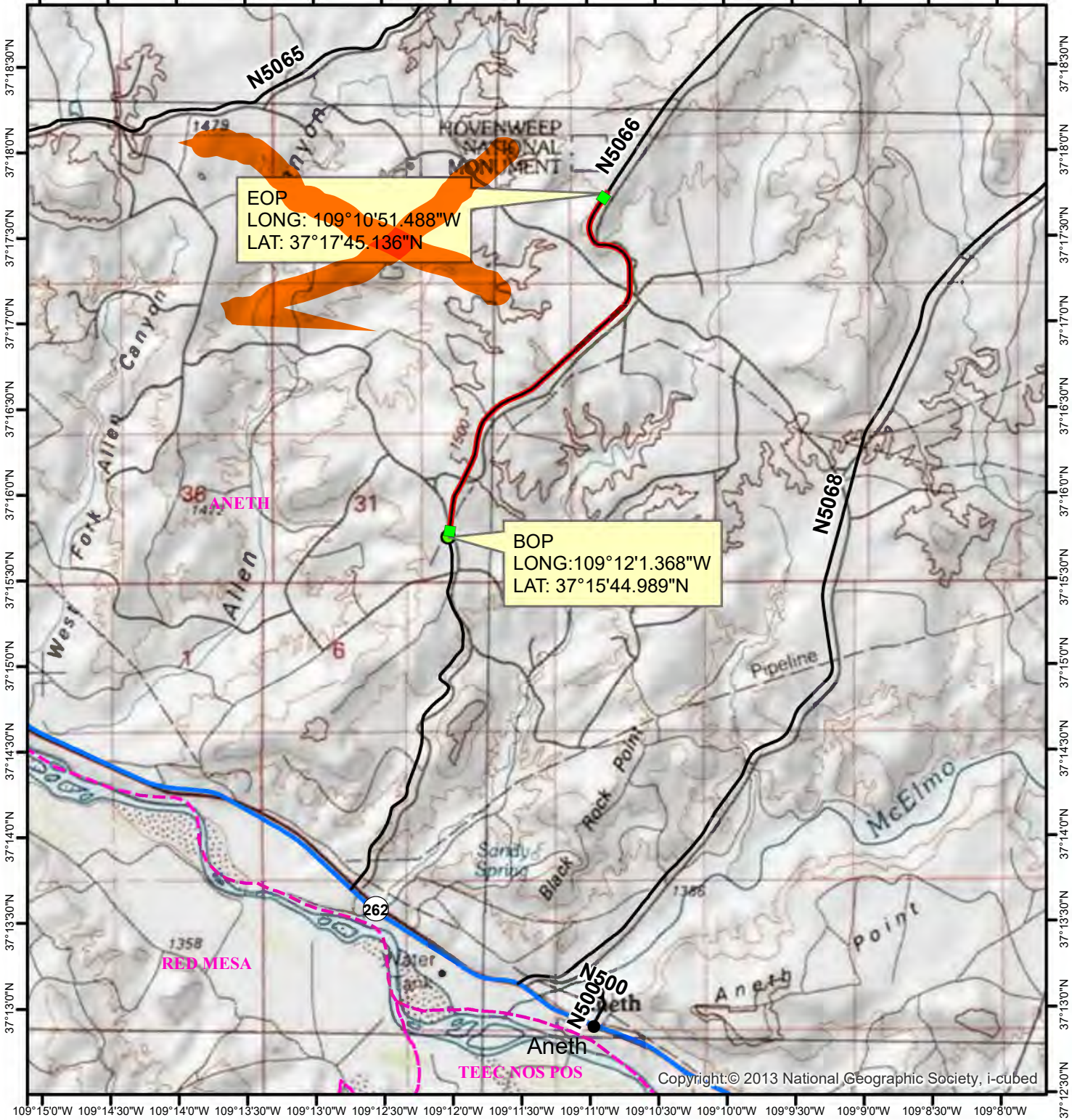

109°15'0"W 109°14'30"W 109°14'0"W 109°13'30"W 109°13'0"W 109°12'30"W 109°12'0"W 109°11'30"W 109°11'0"W 109°10'30"W 109°10'0"W 109°9'30"W 109°9'0"W 109°8'30"W 109°8'0"W

- Chapter House
- N5066
- BIA Roads
- - - Chapter Boundary

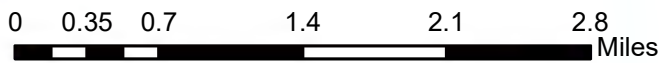

Route: N5066  
 Length: 3 Miles  
 Date: Mar 17, 2021  
 Ownership: BIA



# N5066-Aneth

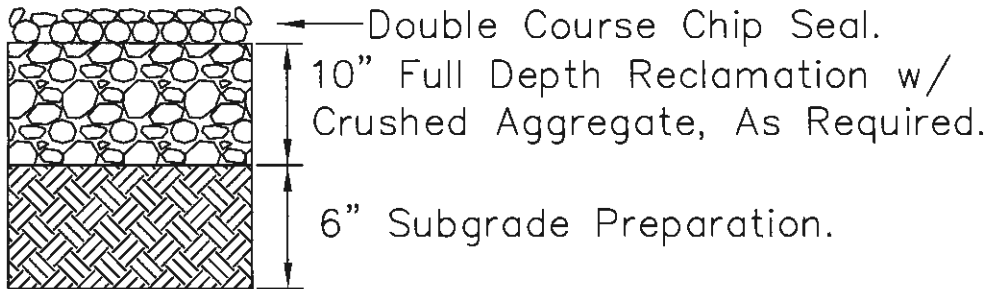
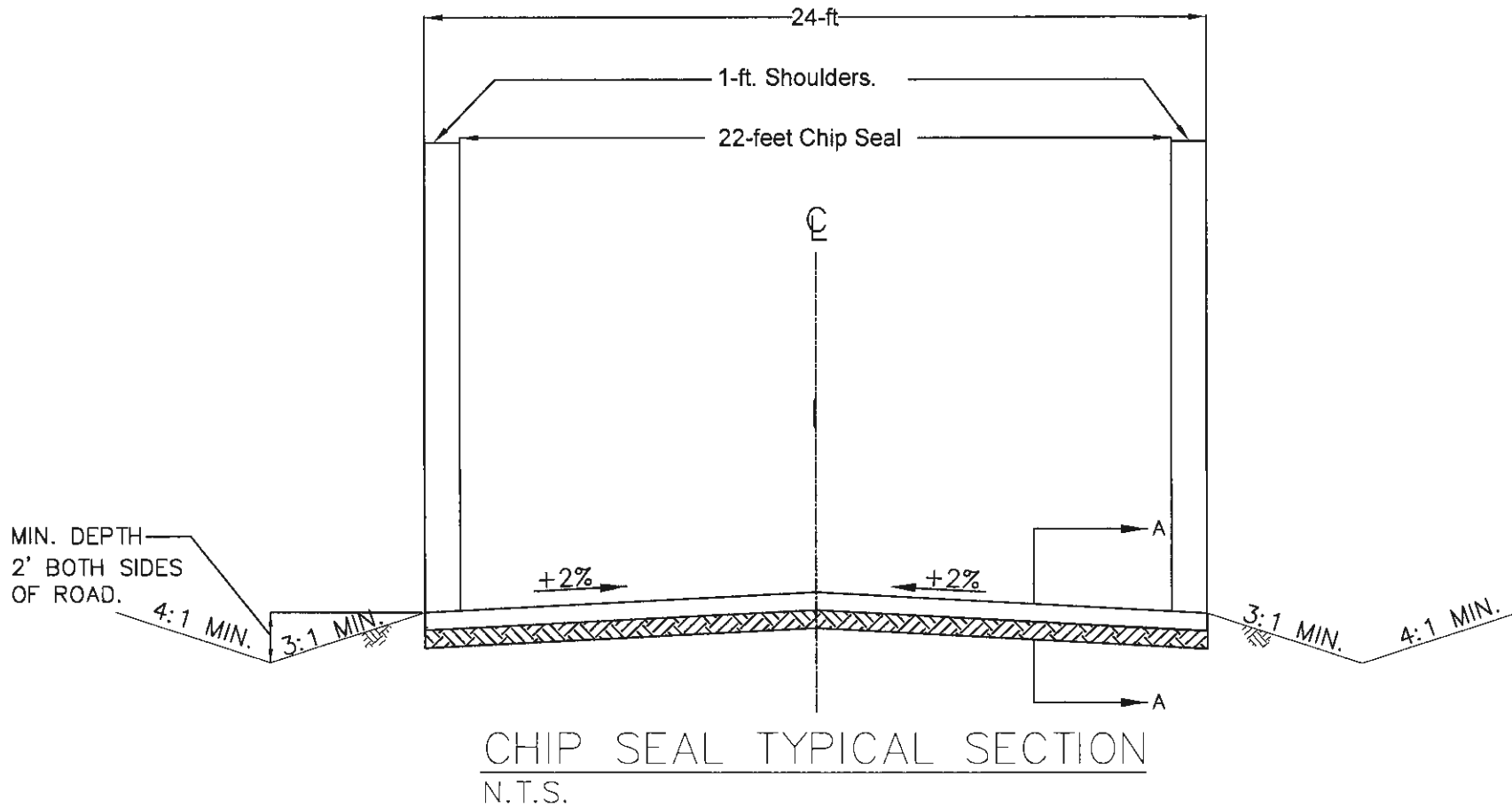

Section A-A  
N.T.S.

<b>Aneth Chapter</b>			
<b>Navajo Division of Transportation</b>			
ROUTE: N5066 - Aneth, UT			
TYPICAL SECTION			
REVISIONS	NO.	DATE	REMARKS
DESIGNED BY: DJ			DATE: January 11, 2022
DRAWN BY: DJ			
			SHEET NO. 1 of 1

**N5066-Aneth, UT; Re-Bid #21-11-2609LE**

January 13, 2022

**BID SCHEDULE**

BID ITEM	FP-14 ITEM	Item Description	Estimated Quantity	Unit	Unit Price	Total
1	151	Mobilization	All Required	LS		
2	152	Construction Survey and Staking	All Required	LS		
3	154	Contractor Sampling and Testing	All Required	LS		
4	204	Furrow Ditches.	1	LS		
5	303	Road Reconditioning.	2.0	Mile		
6	304	FULL DEPTH RECLAMATION	2.0	Mile		
7	406	Fog Seal.	25,825	SY		
8	407	Double Course Chip Seal.	25,825	SY		
9	607	CLEANING, RELAYING, AND REPAIRING EXISTING DRAINAGE STRUCTURES	All Required	LS		
10	633	Permanent Traffic Control: Furnish all materials, equipment, and labor to complete roadway signage, per plans and specifications complete.	1	LS		
11	634	PERMANENT PAVEMENT MARKINGS: Type B, 4-inch Solid Double Yellow.	10,560	LF		
12	635	Temporary Traffic Control Plan.	All Required	LS		
13	70306	Crushed Aggregate.	4,500	Ton		
14	N/A	Contingency.				\$33,018.87
		SUBTOTAL				
		Navajo Nation Tribal Tax - 6%.				
		TOTAL PROJECT COST.				

Note: Payment will be made per FP-14, Section 109.05, and will be made for the actual quantities of work performed and accepted or material furnished according to the contract. No payment will be made for work performed in excess of that staked, ordered, or otherwise authorized.

FP-14 can be downloaded from the following FHWA website:

<https://flh.fhwa.dot.gov/resources/specs/fp-14/fp14.pdf>



# STANDARD SPECIFICATIONS FOR CONSTRUCTION OF ROADS AND BRIDGES ON FEDERAL HIGHWAY PROJECTS

## FP-14



U.S. Department  
of Transportation

**Federal Highway  
Administration**

Federal Lands Highway

## **Section 151. — MOBILIZATION**

### **Description**

**151.01** This work consists of moving personnel, equipment, material, and incidentals to the project and performing work necessary before beginning work at the project site. This work also includes obtaining permits, insurance, and bonds.

### **Measurement**

**151.02** Measure the Section 151 items listed in the bid schedule according to Subsection 109.02.

### **Payment**

**151.03** The accepted quantities will be paid at the contract price per unit of measurement for the Section 151 pay items listed in the bid schedule. Payment will be full compensation for the work prescribed in this Section. See Subsection 109.05.

Progress payments for mobilization by the lump sum will be paid as follows:

- (a)** Bond premiums will be reimbursed according to FAR Clause 52.232-5 Payments Under Fixed-Price Construction Contracts, after receipt of the evidence of payment.
- (b)** When 5 percent of the original contract amount is earned from pay items (not including mobilization), 50 percent of the mobilization pay item, or 5 percent of the original contract amount, whichever is less, will be paid.
- (c)** When 10 percent of the original contract amount is earned from pay items (not including mobilization), 100 percent of the mobilization pay item, or 10 percent of the original contract amount, whichever is less, will be paid.
- (d)** Any portion of the mobilization pay item in excess of 10 percent of the original contract amount will be paid after final acceptance.

## Section 152. — CONSTRUCTION SURVEY AND STAKING

### Description

**152.01** This work consists of performing surveying, staking, calculating, and recording data for the control of work. See FAR Clause 52.236-17 Layout of Work.

### Construction Requirements

**152.02 Qualifications.** Provide technically qualified survey crews experienced in highway construction survey and staking. Provide personnel capable of performing in a timely and accurate manner.

**152.03 Submittals.** Submit the following at the preconstruction conference:

Include the following when Automated Machine Guidance (AMG) methods are used:

**(a) Technology statement.** A written statement that includes:

- (1) The manufacturer, model, and software version of the AMG equipment; and
- (2) Certification that the final 3D data is compatible with the AMG equipment.

**(b) Personnel qualifications.**

- (1) The name, authority, relevant experience, and qualifications of the person with overall responsibility for the AMG system.
- (2) The names, authority, and relevant experience of personnel directly responsible for operating the AMG equipment.

**(c) Contractor quality control plan.** Comply with Section 153 and describe procedures for checking, mechanical calibration, and maintenance of both survey and construction equipment. Include the frequency and types of checks performed.

Include a price breakdown by individual tasks when construction survey and staking is paid by the lump sum for use in making progress payments and price adjustments.

**152.04 General.** Conform to the following:

- (a) Personnel.** Provide a crew supervisor on the project whenever surveying and staking is in progress.
- (b) Equipment.** Furnish survey instruments and supporting equipment capable of achieving the specified tolerances.

Construction equipment controlled with a Global Positioning System (GPS) and Robotic Total Station (RTS) machine guidance system may be used in the construction of subgrade, subbase, and base aggregate courses, or other construction operations when approved.



**(c) Material.** Furnish acceptable tools and supplies of the type and quality suitable for highway survey work. Furnish stakes and hubs of sufficient length to provide a solid set in the ground with sufficient surface area above ground for necessary legible and durable markings.

Include staking activities in the construction schedule required under Section 155. Include the dates and sequence of each staking activity.

The Government will set horizontal control points, vertical control points, and will provide data for use in establishing control for completion of each element of the work.

Data relating to horizontal and vertical alignment, theoretical slope stake catch points, and other design data will be furnished. Reformatting and additional calculations may be required for the convenient use of the Government-furnished data. Provide immediate notification of apparent errors in the initial staking or in the Government-furnished data.

Record survey and measurement field data in an approved format. Submit as-staked data and corrections made to the Government-furnished survey data. Submit survey and measurement data at least weekly. Field data and supporting documentation become the property of the Government upon completion of the work.

Discuss and coordinate the following with the CO before surveying or staking:

- (1) Surveying and staking methods;
- (2) Stake marking;
- (3) Grade control for courses of material;
- (4) Referencing;
- (5) Structure control;
- (6) Field staking data;
- (7) Localization of the GPS systems to the Government-established control points; and
- (8) Other procedures and controls necessary for the work.

Do not start work until staking or three-dimensional (3D) verification data for the affected work has been approved.

Preserve initial reference and control points. Notify the CO of missing control points or stakes at least 10 days before beginning construction. The Government will reestablish control points missing before the beginning of construction.

Acceptance of the construction staking does not relieve the Contractor of responsibility for correcting errors discovered during the work and for bearing additional costs associated with the error.

Maintain legibility of stake markings for the duration of the project or until notified in writing the stakes are no longer needed. Replace stakes if necessary to ensure markings are maintained.

Remove and dispose of flagging, paint, lath, stakes, and other staking material after the project is complete.

**152.05 Survey and Staking Requirements.** Perform survey, staking, recording of data, and calculations as necessary to construct the project from the initial layout to final completion. Survey and set stakes to the tolerances in Table 152-1. Reset stakes, refine 3D data, or both as many times as necessary to construct the work.

**(a) Control points.** Relocate initial horizontal and vertical control points in conflict with construction to areas that will not be disturbed by construction operations. Furnish the coordinates, elevations, and supporting documentation for the relocated points before the initial points are disturbed. Set durable monuments for survey control that uniquely identify the points.

Furnish the GPS localization results at least 7 days before beginning construction layout survey work. The CO may order the GPS localization calibration and associated 3D model to be broken into two or more zones to maintain the localized relationship between control points and original ground.

**(b) Centerline establishment.** Establish or reestablish centerline at roadway design cross-section locations and as necessary to construct the work. Reestablish the centerline when construction survey and staking work does not meet the tolerances.

**(c) Original ground topographic verification.** Use an approved method to regenerate cross-section data in areas where theoretical and actual ground elevations do not meet a tolerance of plus or minus 0.5 feet (150 millimeters). Retake cross-section to verify existing ground topography to mapping. Submit cross-section or 3D data in electronic and printed format for approval. Reduce cross-sections to horizontal and vertical distances from centerline.

Retake cross-section 10 feet (3 meters) beyond catch points to verify existing ground topography.

**(d) Slope and references stakes.** Perform the following:

**(1) AMG method.** After clearing operations are completed, set centerline reference stakes and hubs on both sides of centerline at 100-foot (30-meter) intervals at the clearing limit locations. Where clearing limits are greater than 10 feet (3 meters) vertically, 25 feet (8 meters) horizontally, or both from subgrade hinge point; provide an additional reference stake and hub as approved by the CO. Label each centerline reference stake with station, hub elevation, and offset from centerline.

Construct a 1000-foot (300-meter) long test section using AMG on the project at an approved location before beginning grading operations. Select a test location with superelevation and curve widening transitions if applicable. Notify the CO 10 days before beginning the test section. Demonstrate capability, knowledge, equipment, and experience to achieve work within tolerances. Allow 14 days to evaluate the test section. Do not start full grading operations until the test section is approved.

Provide as-built cross-sections at random locations specified by the CO not to exceed 500-foot (150-meter) intervals. If as-built cross-sections do not meet the tolerances in Subsection 204.13(d); rework the section until the specified tolerances are achieved and provide additional cross-sections as directed by the CO at no cost to the Government.

**(2) Conventional survey methods.** Verify and set slope stakes on both sides of centerline at the theoretical catch point. If the theoretical catch point is not within a tolerance of 0.5 feet (150 millimeters), perform original ground topographic verification according to Subsection 152.05(c). Set the slope stake at the actual intersection of the design roadway slope with the natural ground-line. Set reference stakes outside the clearing limits. Include reference points and slope-stake information on the reference stakes.

Establish slope stakes in the field as the actual point of intersection of the design roadway slope with the natural ground-line when theoretical catch point information is not available.

**(e) Clearing and grubbing limits.** Set clearing and grubbing limits on both sides of centerline based on the actual slope-stake locations.

**(f) Grade-finishing stakes.**

**(1) AMG method.** Construct a 1000-foot (300-meter) long test section using AMG on the project at an approved location before beginning grading operations. Select a test location with superelevation and curve widening transitions if applicable. Notify the CO 10 days before beginning the test section. Demonstrate the capability, knowledge, equipment, and experience to achieve work within tolerances. Allow 14 days to evaluate the test section. Do not start full grading operations until the test section is approved.

Verify the grade elevation and horizontal alignment of roadway grade-finishing operations. Use conventional survey methods at random locations specified by the CO, not to exceed 500-foot (150-meter) intervals. Submit 3D coordinates of grade-finishing quality control checks.

**(2) Conventional survey methods.** Set grade-finishing stakes for grade elevations and horizontal alignment, on centerline and on each shoulder at design roadway cross-section locations. Set stakes at the top of subgrade and the top of each aggregate course. Reset grade finishing stakes as many times as necessary to construct the subgrade and each aggregate course.

During turnout or pullout construction, set stakes on the centerline, on each normal shoulder, and on the shoulder of the turnout. In parking areas, set stakes at the center and along the edges of the parking area. Set stakes in ditches to be paved.

When the centerline curve radius is less than or equal to 250 feet (75 meters), use a maximum longitudinal spacing between stakes of 25 feet (8 meters). When the centerline curve radius is greater than 250 feet (75 meters), use a maximum longitudinal spacing between stakes of 50 feet (15 meters). Use a maximum transverse spacing between stakes of 20 feet (6 meters). Use brushes or guard stakes at each stake.

**(g) Culverts.** Verify and set culvert locations at the inlet, outlet, and inlet basin points according to the plans. Perform the following if culvert design does not fit field conditions:

**(1)** Survey and record the ground profile along the culvert centerline;

**(2)** Determine the slope catch points at the inlet and outlet;

**(3)** Set reference points and record information necessary to determine culvert length and end treatments;

**(4)** Plot to scale the profile along the culvert centerline. Show the natural ground, the flow line, the roadway section, and the culvert including end treatments and other appurtenances. Show elevations, grade, culvert length, and degree of elbow.

*(a)* For single skewed culverts, submit a plotted field-design cross-section normal to roadway centerline and at each end section. Plot the offset and elevation of natural ground at the end section and at proposed template break points between centerline and the end section. Ensure the template design embankment slope is not exceeded;

*(b)* For multiple skewed culverts, submit a plotted field design cross-section normal to roadway centerline and at the end sections (left and right) nearest to the shoulder. Plot the offset and elevation of natural ground at the end section and at proposed template break points between centerline and the end section. Ensure the template design embankment slope is not exceeded;

*(c)* Submit the plotted field-design cross-section for approval of final culvert length and alignment. Plot at a clear and readable scale;

*(d)* Set inlet, outlet, and reference stakes when the field design has been approved. Stake inlet and outlet ditches to make sure the culvert and end treatments (such as drop inlets) are functional; and

*(e)* Adjust slope, reference, and clearing stakes as necessary to provide for culvert inlet treatments in cut slopes. Readjust slope, reference, and clearing stakes as necessary when culvert inlets are moved from their plan locations. Review slope adjustments with the CO and obtain approval.

**(h) Bridges.** Set adequate horizontal and vertical control and reference points for bridge substructure and superstructure components. Establish and reference the bridge chord, bridge tangent, or control lines as specified on the bridge plans. Also establish and reference the centerline of each pier, bent, and abutment.

**(i) Retaining walls and reinforced soil slopes.** Survey and record profile measurements along the face of the proposed wall or reinforced soil slope at 5 feet (1.5 meters) and 10 feet (3 meters) in front of the wall or slope face. Take cross-sections every 25 feet (8 meters) along the length of the wall or reinforced soil slope and at major breaks in terrain within the limits designated by the CO. Measure and record points every 25 feet (8 meters) and at major breaks in terrain for each cross-section. Set additional references and control points to perform the work.

**(j) Borrow and waste sites.** Perform field work necessary for initial layout and measurement of the borrow or waste site. Establish site limits and clearing limits. Measure both original and final ground conditions and submit cross-sections as directed by the CO.

**(k) Permanent monuments and markers.** Perform survey and staking work necessary to establish permanent monuments and markers as described in Section 621 or reestablish monuments as described in Subsection 107.02.

**(l) Miscellaneous survey and staking.** Survey and stake other work (such as guardrail, curb and gutter, turf establishment, utilities, and excavation limits for structures) to the proper location and required tolerances. Propose staking increments for approval by the CO when not specified.



**Table 152-1**  
**Construction Survey and Staking Tolerances <sup>(1)</sup>**

Staking Phase	Horizontal	Vertical
Control points set from existing Government control points	±0.03 feet (±10 millimeters)	±0.01 feet × √N (±3 millimeters × √N) <sup>(2)</sup>
Mapping, topography, and cross-section points	±0.16 feet (±50 millimeters)	±0.16 feet (±50 millimeters)
Centerline points <sup>(3)</sup> including (PC), (PT), (POT),(POC), and references	±0.06 feet (±20 millimeters)	±0.06 feet (±20 millimeters)
Slope-stake and slope-stake references <sup>(4)</sup>	±0.16 feet (±50 millimeters)	±0.16 feet ±50 millimeters)
Culverts, ditches, and minor drainage structures stakes	±0.16 feet (±50 millimeters)	±0.06 feet (±20 millimeters)
Retaining walls stakes	±0.06 feet (±20 millimeters)	±0.03 feet (±10 millimeters)
Curb and gutter stakes	±0.06 feet (±20 millimeters)	±0.03 feet (±10 millimeters)
Bridge substructures stakes	±0.03 feet (±10 millimeters) <sup>(5)</sup>	±0.03 feet (±10 millimeters)
Bridge superstructures stakes	±0.03 feet (±10 millimeters) <sup>(5)</sup>	±0.03 feet (±10 millimeters)
Clearing and grubbing limit stakes	±1.00 feet (±300 millimeters)	-
Roadway subgrade finish stakes <sup>(6)</sup>	±0.16 feet (±50 millimeters)	±0.03 feet (±10 millimeters)
Roadway finish grade stakes <sup>(6)</sup>	±0.16 feet (±50 millimeters)	±0.03 feet (±10 millimeters)

(1) At statistical 95 percent confidence level. Tolerances are relative to existing Government control points.

(2) N is the number of instrument setups.

(3) Centerline points: PC - point of curve, PT - point of tangent, POT - point on tangent, POC - point on curve.

(4) Take the cross-sections normal to the centerline ±1 degree.

(5) Bridge control is established as a local network and the tolerances are relative to that network.

(6) Includes paved ditches.

**152.06 Acceptance.** Construction survey and staking will be evaluated under Subsections 106.02 and 106.04.

Survey notes will be evaluated under Subsection 106.02.

### **Measurement**

**152.07** Measure the Section 152 pay items listed in the bid schedule according to Subsection 109.02 and the following as applicable:

When measuring grade finishing, measure one time for the subgrade and one time for each aggregate course.

When measuring miscellaneous survey and staking paid by the hour; do not measure time spent in making preparations, traveling to and from the project site, performing calculations, plotting cross-sections and other data, processing computer data, and other efforts necessary to successfully accomplish construction survey and staking.

Do not measure re-establishing missing control points or stakes after construction operations have begun.

### **Payment**

**152.08** The accepted quantities will be paid at the contract price per unit of measurement for the Section 152 pay items listed in the bid schedule. Payment will be full compensation for the work prescribed in this Section. See Subsection 109.05.

Payment for lump sum pay items will be prorated based on the progress of the work under this Section.

## Section 153. — CONTRACTOR QUALITY CONTROL

### Description

**153.01** This work consists of planning and implementing a construction quality process to ensure work conforms to the contract. This work also includes quality control inspection and documentation, and process control sampling and testing. See FAR Clause 52.246-12 Inspection of Construction.

### Construction Requirements

**153.02 Qualifications.** Submit the following for approval with the Quality Control Plan:

**(a) Quality control manager (QCM).** Provide a QCM according to (1) or (2) below. If neither is specified, conform to (1).

**(1) Full-time, on-site QCM.** Provide a QCM with no responsibilities for performing testing and inspection, managing the project, or performing operations other than managing quality control and the following:

*(a)* One year experience managing quality control on construction projects of similar type and scope, and

*(b)* One of the following:

*(1)* Two years' experience as a construction project manager or superintendent on construction projects of similar type and scope;

*(2)* Three years' experience as a project engineer, resident engineer, foreman, construction inspector, or equivalent on construction projects of similar type and scope;  
or

*(3)* National Institute for Certification in Engineering Technologies (NICET) Level III certification or equivalent in highway construction or highway material.

**(2) Part-time, on-site QCM.** Furnish a QCM who has at least 2 years' experience in highway construction, inspection, quality control, and material testing.

**(b) Inspectors.** Provide inspectors with at least 2 years' experience inspecting projects of similar complexity and with training related to the work to be inspected.

**(c) Testers.** Provide testers with at least one year experience in the type of sampling and testing required, and with one of the following for the type of sampling and testing performed:

**(1)** NICET Level II certification in highway material or equivalent state or industry certification;

**(2)** Certification by a regional certification program (such as Western Alliance for Quality Transportation Construction (WAQTC), Northeast Transportation Technician Certification Program (NETTCP), Southeast Task Force for Technician Training and Qualification (STFTTQ), or Multi Regional Training and Certification (M-TRAC)); or

**(3)** At least one year employment by an AASHTO accredited laboratory performing equivalent sampling and testing.

**153.03 Quality Control Plan (QCP).** Develop a QCP addressing all contract work categories. A category consists of related work items performed in one operation (such as excavation, drainage, and paving). Include the work of subcontractors, major material suppliers, and structural and geotechnical services suppliers.

For each category, include the following:

**(a) Quality control personnel.** Furnish the name, authority, responsibilities, and qualifications of the quality control manager and other personnel directly involved in inspection and testing. Conform to Subsection 153.02.

**(b) Quality control procedures.** Describe the inspection, testing, and other activities to be performed for each phase of work in Subsection 153.04. Include methods, schedules, equipment, and laboratory facilities. Conform to Subsections 153.04 and 153.05.

List the material to be tested by:

- (1) Pay item;
- (2) Applicable requirements of the Sampling, Testing, and Acceptance Requirements tables;
- (3) Persons responsible for performing the sampling and testing;
- (4) Laboratory testing facilities to be used for process control and project testing; and
- (5) Proposed reporting formats.

As a minimum perform process control testing according to the Sampling, Testing, and Acceptance Requirements tables included at the end of each Section where applicable.

**(c) Records.** Describe the reporting format for inspection, testing, certification, and daily reports. Conform to Subsections 153.06 and 153.07.

At least 14 days before the start of work, submit the QCP for approval. Do not perform work on a work category unless the quality control for that category is accepted. Approval does not imply that the QCP will result in contract compliance.

Revise the QCP when contract quality requirements are not achieved and when changes occur in the contract, work progress, or personnel.

**153.04 Prosecution of Work.** Complete the following:

**(a) Preparatory phase.**

(1) Before starting each work category, hold a preparatory phase meeting. Include the project superintendent, work foreman, CO, QCM, and appropriate subcontractors. Be prepared to discuss the following:

- (a) Contract requirements for the work, including acceptance procedures, schedule, and control strip;
- (b) Process and equipment for constructing the work; and



(c) Plan for inspection, process control, testing, measuring, and reporting the work.

- (2) Review and coordinate certifications, submittals, plans, drawings, and permits.
- (3) Verify the capabilities of equipment, material, and personnel. Provide training as necessary.
- (4) Establish a detailed testing schedule based on the production schedule.
- (5) Ensure preparatory testing and inspection is accomplished.
- (6) Review accuracy of the surveying and staking.

**(b) Start-up phase.**

- (1) Hold a start-up meeting to review the contract, the construction processes, and the inspection, testing, and reporting requirements with the personnel performing the work. Include the project superintendent, inspectors, testers, CO, and QCM. Explain procedures that will be followed if defective work is identified.
- (2) Inspect, test, and report start-up work according to the QCP and ensure the work conforms to the contract.

**(c) Production phase.**

- (1) Inspect, test, and report according to the QCP and evaluate the acceptability of the work produced.
- (2) Identify and correct deficiencies.
- (3) Request Government inspection and acceptance.

**153.05 Sampling and Testing.** Inspect commercial laboratory equipment within 45 days of project use.

Have mobile laboratory equipment inspected and calibrated after the laboratory is moved to the project and every time it is moved thereafter. Keep laboratory facilities clean and maintain equipment in proper working condition. Certify that equipment conforms to testing requirements and submit evidence of current calibrations.

Allow the CO unrestricted access to the laboratory for inspection and review. When requested by the CO, provide additional inspections and tests to demonstrate sampling and testing proficiency. Submit proficiency sample test results within 48 hours of sample receipt.

Perform quality control sampling and testing according to the QCP and the sampling, testing, and acceptance requirements table in applicable sections.

When no sampling frequencies are specified, submit the proposed sampling and testing frequencies.

**153.06 Certifications.** Obtain, review, and verify certifications for work. Submit certifications when required.

**153.07 Records and Control Charts.** Maintain records and control charts by pay item.

**(a) Quality control and construction operations reports.** Submit written quality control and construction operations reports daily according to the QCP. Document meetings, work locations, labor and equipment used including actual hours worked, testing and measurement activities, inspection results, deficiencies observed, corrective actions taken, and process changes. Use FHWA Form 1413, *Inspector's Daily Record of Construction Operations* or approved alternate forms. Include the following certification signed by the QCM on all reports:

*"I certify that the information contained in this record is accurate and that work documented herein complies with the contract. Exceptions to this certification are documented as a part of this record."*

**(b) Control charts.** Maintain linear control charts that identify the test number, test parameter, upper and lower specification limit applicable to each test parameter, and test results for applicable material. Use the control charts to document variability of the process, to identify production and equipment problems, and to identify actions to improve processes or quality.

Update and post control charts daily in a location accessible to the CO. Cease production and correct the process when problems are evident.

**153.08 Acceptance.** The Contractor's quality control system will be evaluated under Subsection 106.02 based on its demonstrated effectiveness to ensure work conforms to the contract.

### **Measurement and Payment**

**153.09** Do not measure Contractor quality control for payment. See Subsection 109.05.

## Section 154. — CONTRACTOR SAMPLING AND TESTING

### Description

**154.01** This work consists of obtaining samples for testing.

When there is a pay item for Contractor testing included in the bid schedule, this work also includes sampling, testing and reporting the required test results. It excludes Contractor quality control testing required under Section 153.

### Construction Requirements

**154.02 General.** Include the work required under this Section in the Section 153 quality control plan.

Sample and test material according to the Sampling, Testing, and Acceptance Requirements tables included at the end of each Section. Perform additional sampling and testing as directed when material does not meet requirements.

Provide the CO the opportunity to witness sampling, splitting, and testing of material.

Where process control sampling and testing frequencies are identical to the sampling and testing frequencies for acceptance, the process control samples may be used for acceptance for the applicable work.

**154.03 Sampling.** Sample and split samples according to AASHTO or other acceptable procedures. The location of statistical acceptance sampling will be provided using a random number system. Perform splits when required and deliver the Government's portion of the sample or split sample in an acceptable container suitable for shipment. Label samples with the following:

- (a) Project number and name;
- (b) Pay item number and description;
- (c) Source of material;
- (d) Sample number;
- (e) Date sampled;
- (f) Time sampled;
- (g) Location sample taken;
- (h) Name of person sampling;
- (i) Name of person witnessing sampling; and
- (j) Type of test required on sample.

**154.04 Testing.** Perform tests when there is a pay item for Contractor testing included in the bid schedule. Demonstration of testing competence may be required.

**154.05 Records.** When tests are on material being incorporated in the work, report test results within 24 hours unless specified otherwise in the Sampling, Testing, and Acceptance Requirements tables. Report test results on forms containing sample information required by Subsection 154.03. Label interim measurements used to determine the results. Attach work sheets used to determine test values to the test result forms. Payment for work may be delayed or the work stopped until test results are submitted.

**154.06 Acceptance.** Contractor sampling and testing will be evaluated under Subsections 106.02 and 106.04 based on Government verification testing.

### **Measurement**

**154.07** Measure the Section 154 pay items listed in the bid schedule according to Subsection 109.02.

### **Payment**

**154.08** The accepted quantities will be paid at the contract price per unit of measurement for the Section 154 pay items listed in the bid schedule. Payment will be full compensation for the work prescribed in this Section. See Subsection 109.05.

Progress payments for Contractor testing lump sum will be paid as follows:

- (a) 25 percent of the pay item amount, not to exceed 0.5 percent of the original contract amount, will be paid after the testing facilities are in place, qualified sampling and testing personnel are identified, and the work being tested has started.
- (b) Payment for the remaining portion of the pay item amount will be prorated based on the total work completed in Section 154.

Payment may be retained if Government verification testing does not validate the Contractor testing or if it is determined that documentation of sampling and testing does not meet requirements.



## Section 204. — EXCAVATION AND EMBANKMENT

### Description

**204.01** This work consists of excavating material and constructing embankments. This work also includes furnishing, hauling, stockpiling, placing, disposing, sloping, shaping, compacting, and finishing earthen and rocky material.

#### **204.02 Definitions.**

**(a) Excavation.** Excavation consists of the following:

**(1) Roadway excavation.** Material excavated from within the right-of-way or easement areas, except subexcavation covered in Subsection 204.02(a)(2) and structure excavation covered in Sections 208 and 209. Roadway excavation includes all material encountered regardless of its nature or characteristics.

**(2) Subexcavation.** Material excavated from below subgrade elevation in cut sections or from below the original ground-line in embankment sections. Subexcavation excludes the work required by Subsection 204.05 or 204.06.

**(3) Borrow excavation.** Material used for embankment construction that is obtained from outside the roadway prism. Borrow excavation includes unclassified borrow, select borrow, and topping.

**(b) Embankment construction.** Embankment construction consists of placing and compacting roadway or borrow excavation. This work includes:

**(1)** Preparing foundation for embankment;

**(2)** Constructing roadway embankments;

**(3)** Benching for side-hill embankments;

**(4)** Constructing dikes, ramps, mounds, and berms; and

**(5)** Backfilling subexcavated areas, holes, pits, and other depressions.

**(c) Conserved topsoil.** Excavated material conserved from the roadway excavation and embankment foundation areas that is suitable for growth of grass, cover crops, or native vegetation.

**(d) Waste.** Excess and unsuitable roadway excavation and subexcavation that cannot be used.

## Material

**204.03** Conform to the following Subsections:

Select borrow	704.07
Topping	704.05
Unclassified borrow	704.06
Water	725.01(c)

## Construction Requirements

**204.04 Preparation for Roadway Excavation and Embankment Construction.** Clear the area of vegetation and obstructions according to Sections 201 and 203.

Road pioneering may proceed concurrently with excavation and embankment. Maintain drainage during pioneering operations.

**204.05 Conserved Topsoil.** Conserve topsoil from roadway excavation and embankment foundation areas. Stockpile conserved topsoil in low windrows immediately beyond the rounding limits of cut and embankment slopes or in other approved locations. Separate topsoil from other excavated material.

Place conserved topsoil on completed slopes according to Section 624.

**204.06 Roadway Excavation.** Excavate as follows:

(a) **Rock cuts.** Blast rock according to Section 205. Excavate rock cuts to 6 inches (150 millimeters) below subgrade within the roadbed limits. Backfill to subgrade with topping or other suitable material. Compact the material according to Subsection 204.11.

(b) **Earth cuts.** Scarify earth cuts to 6 inches (150 millimeters) below subgrade within the roadbed limits. Compact the scarified material according to Subsection 204.11.

Dispose of unsuitable or excess excavation material according to Subsection 204.14. Replace shortage of suitable material caused by premature disposal of roadway excavation.

Shape to drain and compact the work area to a uniform cross-section at the end of each day's operations.

**204.07 Subexcavation.** Excavate material to the required limits. Dispose of unsuitable material according to Subsection 204.14. Take cross-sections according to Section 152. Place backfill material in horizontal layers not exceeding 12 inches (300 millimeters) in compacted thickness and compact according to Subsection 204.11. Prevent unsuitable material from mixing with backfill.

**204.08 Borrow Excavation.** Use suitable roadway excavation in embankment construction. Do not use borrow excavation when it results in excess roadway excavation. Deduct excess borrow excavation from the total borrow excavation quantity.

Obtain borrow source approval according to Subsection 105.02. Develop and restore borrow sources according to Subsections 105.03 and 105.06. Do not excavate beyond the established limits. When applicable, shape the borrow source to permit accurate measurements when excavation is complete.

**204.09 Preparing Foundation for Embankment Construction.** Prepare foundation for embankment construction as follows:

**(a) Embankment over natural ground.** Remove topsoil and break up the ground surface to a minimum depth of 6 inches (150 millimeters) by plowing or scarifying. Compact the ground surface according to Subsection 204.11.

**(b) Embankments over an existing asphalt, concrete, or gravel road surface.** Scarify gravel roads to a minimum depth of 6 inches (150 millimeters). Scarify or pulverize asphalt and concrete roads to 6 inches (150 millimeters) below the pavement. Reduce particles to a maximum size of 6 inches (150 millimeters) and produce a uniform material. Compact the surface according to Subsection 204.11.

**(c) Embankment across ground not capable of supporting equipment.** Dump successive loads of embankment material in a uniformly distributed layer to construct the lower portion of the embankment. Limit the layer thickness to the minimum depth necessary to support the equipment.

**(d) Embankment on an existing slope steeper than 1V:3H.** Cut horizontal steps in the existing slope to a sufficient width to accommodate placement and compaction operations and equipment. Step the slope as the embankment is placed and compacted in layers. Begin each step at the intersection of the original ground and the vertical cut of the previous step.

**204.10 Embankment Construction.** Incorporate only suitable roadway excavation material into the embankment. When the supply of suitable roadway excavation is exhausted, furnish unclassified borrow to complete the embankment. Construct embankments as follows:

**(a) General.** At the end of each day's operations, shape to drain and compact the embankment surface to a uniform cross-section. Eliminate ruts and low spots that could hold water.

During all stages of construction, route and distribute hauling and leveling equipment over the width and length of each layer of material.

Compact embankment side slopes with a tamping foot roller, by walking with a dozer, or by over-building the fill and then removing excess material to the final slope line. For slopes 1V:1¼H or steeper, compact the slopes as embankment construction progresses.

**(b) Embankment within the roadway prism.** Place embankment material in horizontal layers not exceeding 12 inches (300 millimeters) in compacted thickness. Incorporate oversize boulders or rock fragments into the 12-inch (300-millimeter) layers by reducing them in size or placing them individually as required by Subsection 204.10(c). Compact each layer according to Subsection 204.11 before placing the next layer.

Material composed predominately of boulders or rock fragments too large for 12-inch (300-millimeter) layers may be placed in layers up to 24 inches (600 millimeters) thick. Incorporate oversize boulders or rock fragments into the 24-inch (600-millimeter) layer by reducing them in size or placing individual rock fragments and boulders greater than 24 inches (600 millimeters) in diameter as follows:

- (1) Reduce rock to less than 48 inches (1200 millimeters) in the largest dimension;
- (2) Distribute rock within the embankment to prevent nesting;

(3) Place layers of embankment material around each rock to a depth not greater than that permitted by Subsection 204.10(b). Fill voids between rocks; and

(4) Compact each layer according to Subsection 204.11(a) before placing the next layer.

(c) **Embankment outside of roadway prism.** When placing embankment outside the staked roadway prism, place material in horizontal layers not exceeding 24 inches (600 millimeters) in compacted thickness. Compact each layer according to Subsection 204.11.

**204.11 Compaction.** For compaction, use AASHTO T 27 to determine the quantity of material retained on a No. 4 (4.75-millimeter) sieve. Compact as follows:

(a) **More than 80 percent retained on a No. 4 (4.75-millimeter) sieve.** Adjust the moisture content to a level suitable for compaction. Fill the interstices around rock with earth or other fine material as practical. Use compression-type rollers at speeds less than 6 feet (1.8 meters) per second and vibratory rollers at speeds less than 3 feet (1 meter) per second. Compact each layer of material full width with one of the following and until there is no visible evidence of further consolidation:

(1) Four roller passes of a vibratory roller having a minimum dynamic force of 40,000 pounds (180 kilonewtons) impact per vibration and a minimum frequency of 1000 vibrations per minute;

(2) Eight roller passes of a 20-ton (20-metric ton) compression-type roller; or

(3) Eight roller passes of a vibratory roller having a minimum dynamic force of 30,000 pounds (130 kilonewtons) impact per vibration and a minimum frequency of 1000 vibrations per minute.

Increase the compactive effort for layers deeper than 12 inches (300 millimeters) as follows:

- For each additional 6 inches (150 millimeters) or fraction thereof, increase the number of roller passes in Subsection 204.11(a)(1), by four passes; or
- For each additional 6 inches (150 millimeters) or fraction thereof, increase the number of roller passes in Subsection 204.11(a)(2) and (3), by eight passes.

(b) **50 to 80 percent retained on a No. 4 (4.75-millimeter) sieve.** Classify the material according to AASHTO M 145. Adjust the moisture content of material classified A-1 through A-5 to a moisture content suitable for compaction. Adjust the moisture content of material classified A-6 and A-7 to within 2 percent of the optimum moisture content. Use AASHTO T 99 to determine the optimum moisture content of the portion of the material passing a No. 4 (4.75-millimeter) sieve. Multiply this number by the percentage of material passing a No. 4 (4.75-millimeter) sieve, and add 2 percent to determine the optimum moisture content of the material.

Use nonvibratory rollers at speeds less than 6 feet (1.8 meters) per second and vibratory rollers at speeds less than 3 feet (1 meter) per second. Compact each layer of material full width according to Subsection 204.11(a).

(c) **Less than 50 percent retained on a No. 4 (4.75-millimeter) sieve.** Classify the material according to AASHTO M 145. For material classified A-1 or A-2-4, determine the maximum density according to AASHTO T 180, Method D. For other material classifications, determine the optimum moisture content and maximum density according to AASHTO T 99, Method C.



Adjust the moisture content of material classified A-1 through A-5 to a moisture content suitable for compaction. Adjust the moisture content of material classified A-6 and A-7 to within 2 percent of the optimum moisture content.

Use compression-type or vibratory rollers. Compact each layer of material full width to at least 95 percent of the maximum density. Determine the in-place density and moisture content according to AASHTO T 310 or other approved test procedures. When required, use AASHTO T 224 to correct for coarse particles.

**204.12 Ditches.** Slope, grade, and shape ditches. Remove projecting roots, stumps, rock, or similar matter. Maintain ditches in an open condition and without sticks, and other debris.

Form **furrow ditches** by plowing or using other acceptable methods to produce a continuous furrow. Place excavated material on the downhill side so the bottom of the ditch is approximately 18 inches (450 millimeters) below the crest of the loose material. Clean the ditch using a hand shovel or other suitable method. Shape to provide drainage without overflow.

**204.13 Sloping, Shaping, and Finishing.** Complete slopes, ditches, culverts, riprap, and other underground minor structures before placing aggregate courses. Slope, shape, and finish as follows:

**(a) Sloping.** Leave earth slopes with uniform roughened surfaces, except as described in Subsection 204.13(b), with no noticeable break as viewed from the road. Except in solid rock, round tops and bottoms of slopes including the slopes of drainage ditches. Round material overlaying solid rock to the extent practical. Scale rock slopes.

If a slide or slipout occurs on a cut or embankment slope, remove or replace the material and repair or restore damage to the work. Bench or key the slope to stabilize the slide. Reshape the cut or embankment slope to an acceptable condition.

**(b) Stepped slopes.** Where required, construct steps on slopes of 1½V:1H to 1V:2H. Construct the steps approximately 18 inches (450 millimeters) high. Blend the steps into natural ground at the end of the cut. If the slope contains non-rippable rock outcrops, blend steps into the rock. Remove loose material found in transitional area. Except for removing large rocks that may fall, scaling stepped slopes is not required.

**(c) Shaping.** Shape the subgrade to a smooth surface and to the cross-section required. Shape slopes to gradually transition into slope adjustments without noticeable breaks. At the ends of cuts and at intersections of cuts and embankments, adjust slopes in the horizontal and vertical planes to blend into each other or into the natural ground.

**(d) Finishing.** Remove material larger than 6 inches (150 millimeters) from the top 6 inches (150 millimeters) of the roadbed. Remove unsuitable material from the roadbed, and replace it with suitable material. Finish roadbeds that are compacted according to Subsection 204.11(b) and (c) to within ±0.05 foot (±15 millimeters) of the staked line and grade. Finish roadbeds that are compacted according to Subsection 204.11(a) to within ±0.10 foot (±30 millimeters) of the staked line and grade. Finish ditch cross-sections to within ±0.10 feet (±30 millimeters) of the staked line and grade. Maintain proper ditch drainage.

**204.14 Disposal of Unsuitable or Excess Material.** Dispose of unsuitable or excess material according to Subsection 203.05(a).

When there is a pay item for waste, shape and compact the waste material in its final location. Do not mix clearing or other material not subject to payment with the waste material.

**204.15 Acceptance.** See Table 204-1 for sampling, testing, and acceptance requirements.

Material for embankment and conserved topsoil will be evaluated under Subsections 106.02 and 106.04.

Excavation and embankment construction will be evaluated under Subsections 106.02 and 106.04.

Subexcavation will be evaluated under Subsections 106.02 and 106.04.

### **Measurement**

**204.16** Measure the Section 204 pay items listed in the bid schedule according to Subsection 109.02 and the following as applicable:

**(a) Roadway excavation.** Measure roadway excavation in its original position as follows:

**(1)** Include the following volumes in roadway excavation:

- (a) Roadway prism excavation;
- (b) Rock material excavated and removed from below subgrade in cut sections;
- (c) Unsuitable material below subgrade and unsuitable material beneath embankment areas when a pay item for subexcavation is not listed in the bid schedule;
- (d) Ditches, except furrow ditches measured under a separate pay item;
- (e) Conserved topsoil;
- (f) Borrow material used in the work when a pay item for borrow is not listed in the bid schedule;
- (g) Loose scattered rocks removed and placed as required within the roadway;
- (h) Conserved material taken from pre-existing stockpiles and used in Section 204 work, except topsoil measured under Section 624; and
- (i) Slide and slipout material not attributable to the Contractor's method of operation.

**(2)** Do not include the following in roadway excavation:

- (a) Overburden and other spoil material from borrow sources;
- (b) Overbreakage from the backslope in rock excavation;
- (c) Water or other liquid material;
- (d) Material used for purposes other than required;
- (e) Roadbed material scarified in place and not removed;
- (f) Material excavated when stepping cut slopes;
- (g) Material excavated when rounding cut slopes;

- (h) Preparing foundations for embankment construction;
- (i) Material excavated when benching for embankments;
- (j) Slide or slipout material attributable to the Contractor's method of operation;
- (k) Conserved material taken from stockpiles constructed at the option of the Contractor;
- (l) Material excavated outside the established slope limits; and
- (m) Road pioneering for the convenience of the Contractor.

**(3)** When both roadway excavation and embankment construction pay items are listed in the bid schedule, measure roadway excavation only for the following:

- (a) Unsuitable material below subgrade in cuts and unsuitable material beneath embankment areas when a pay item for subexcavation is not listed in the bid schedule;
- (b) Slide and slipout material not attributable to the Contractor's method of operations; and
- (c) Drainage ditches, channel changes, and diversion ditches.

**(b) Unclassified borrow, select borrow, and topping.** When measuring by the cubic yard (cubic meter) measure in its original position. If borrow excavation is measured by the cubic yard (cubic meter) in-place, take initial cross-sections of the ground surface after stripping overburden. Upon completion of excavation and after the borrow source waste material is returned to the source, retake cross-sections before replacing the overburden.

Do not measure borrow excavation until suitable roadway excavation is depleted.

**(c) Embankment construction.** Measure embankment construction in its final position. Do not make deductions from the embankment construction quantity for the volume of minor structures.

**(1)** Include the following volumes in embankment construction:

- (a) Roadway embankments;
- (b) Material used to backfill subexcavated areas, holes, pits, and other depressions;
- (c) Material used to restore obliterated roadbeds to original contours; and
- (d) Material used for dikes, ramps, mounds, and berms.

**(2)** Do not include the following in embankment construction:

- (a) Preparing foundations for embankment construction;
- (b) Adjustments for subsidence or settlement of the embankment or of the foundation on which the embankment is placed; and
- (c) Material used to round fill slopes.

**(d) Rounding cut slopes.** Measure rounding cut slopes horizontally along the centerline of the roadway.

**(e) Waste.** Measure waste by the cubic yard (cubic meter) in its final position. Take initial cross-sections of the ground surface after stripping over-burden. Upon completion of the waste placement, retake cross-sections before replacing overburden.

**(f) Slope scaling.** Measure slope scaling by the cubic yard (cubic meter) in the hauling vehicle.

**(g) Subexcavation.** Measure subexcavation by the cubic yard (cubic meter) in its original position.

### **Payment**

**204.17** The accepted quantities will be paid at the contract price per unit of measurement for the Section 204 pay items listed in the bid schedule. Payment will be full compensation for the work prescribed in this Section. See Subsection 109.05.

**Table 204-1  
Sampling, Testing, and Acceptance Requirements**

<b>Material or Product (Subsection)</b>	<b>Type of Acceptance (Subsection)</b>	<b>Characteristic</b>	<b>Category</b>	<b>Test Methods Specifications</b>	<b>Sampling Frequency</b>	<b>Point of Sampling</b>	<b>Split Sample</b>	<b>Reporting Time</b>
<b>Source</b>								
Topping (704.05)	Measured and tested for conformance (106.04 & 105)	Classification <sup>(1)</sup>	-	AASHTO M 145	1 per soil type and source of material	Source of material	Yes	Before using in work
Unclassified borrow (704.06)	"	"	-	"	"	"	"	"
Select borrow (704.07)	"	"	-	"	"	"	"	"
		Gradation	-	AASHTO T 27 & T 11	"	"	"	"
		Liquid limit	-	AASHTO R 58 & T 89, Method A	"	"	"	"



**Table 204-1 (continued)**  
**Sampling, Testing, and Acceptance Requirements**

<b>Material or Product (Subsection)</b>	<b>Type of Acceptance (Subsection)</b>	<b>Characteristic</b>	<b>Category</b>	<b>Test Methods Specifications</b>	<b>Sampling Frequency</b>	<b>Point of Sampling</b>	<b>Split Sample</b>	<b>Reporting Time</b>
<b>Production</b>								
Topping (704.05)	Measured and tested for conformance (106.04)	Moisture-density	–	AASHTO T 180, Method D <sup>(2)</sup> or T 99, Method C <sup>(2)</sup>	1 per soil type, but not less than 1 per each 13,000 yd <sup>3</sup> (10,000 m <sup>3</sup> )	Processed material	Yes	Before using in work
		Density	–	AASHTO T 310 or other approved procedures	1 per 3500 yd <sup>2</sup> (3000 m <sup>2</sup> ), but not less than 1 per layer	In-place	No	Before placement of next layer
Unclassified borrow (704.06)	"	Moisture-density	–	AASHTO T 180, Method D <sup>(2)</sup> or T 99, Method C <sup>(2)</sup>	1 per soil type, but not less than 1 per each 13,000 yd <sup>3</sup> (10,000 m <sup>3</sup> )	Processed material	Yes	Before using in work
		Density	–	AASHTO T 310 or other approved procedures	1 per 3500 yd <sup>2</sup> (3000 m <sup>2</sup> ), but not less than 1 per layer	In-place	No	Before placement of next layer

**Table 204-1 (continued)**  
**Sampling, Testing, and Acceptance Requirements**

<b>Material or Product (Subsection)</b>	<b>Type of Acceptance (Subsection)</b>	<b>Characteristic</b>	<b>Category</b>	<b>Test Methods Specifications</b>	<b>Sampling Frequency</b>	<b>Point of Sampling</b>	<b>Split Sample</b>	<b>Reporting Time</b>
<b>Production (continued)</b>								
Select borrow (704.07)	Measured and tested for conformance (106.04)	Classification	-	AASHTO M 145	1 per soil type, but not less than 1 for each day of production	Processed material	Yes	Before using in work
		Gradation	-	AASHTO T 27 & T 11	"	"	"	"
		Liquid limit	-	AASHTO R 58 & T 89, Method A	"	"	"	"
		Moisture-density	-	AASHTO T 180, Method D <sup>(2)</sup> or T 99, Method C <sup>(2)</sup>	1 per soil type, but not less than 1 per each 13,000 yd <sup>3</sup> (10,000 m <sup>3</sup> )	"	"	"
		Density	-	AASHTO T 310 or other approved procedures	1 per 3500 yd <sup>2</sup> (3000 m <sup>2</sup> ), but not less than 1 per layer	In-place	No	Before placement of next layer

**Table 204-1 (continued)**  
**Sampling, Testing, and Acceptance Requirements**

Material or Product (Subsection)	Type of Acceptance (Subsection)	Characteristic	Category	Test Methods Specifications	Sampling Frequency	Point of Sampling	Split Sample	Reporting Time
<b>Production (continued)</b>								
Earth embankment (204.11)	Measured and tested for conformance (106.04)	Classification	-	AASHTO M 145	1 per soil type	Source of material	Yes	Before using in work
		Moisture-density	-	AASHTO T 180, Method D <sup>(2)</sup> or T 99, Method C <sup>(2)</sup>	1 per soil type, but not less than 1 per each 13,000 yd <sup>3</sup> (10,000 m <sup>3</sup> )	"	"	"
		Density	-	AASHTO T 310 or other approved procedures	1 per 3500 yd <sup>2</sup> (3000 m <sup>2</sup> ), but not less than 1 per layer	In-place	No	Before placement of next layer
Top of subgrade (204.11)	"	Density	-	AASHTO T 310 or other approved procedures	1 per 2500 yd <sup>2</sup> (2000 m <sup>2</sup> ), but not less than 1 per layer	In-place	No	Before placement of next layer
<b>Finished Product</b>								
Roadbed (204.13)	Measured and tested for conformance (106.04)	Final line & grade	-	Field measured	Determined by the CO	Determined by the CO	No	Before placement of next layer

(1) Not required when using Government-provided source.

(2) Minimum 5 points per proctor.

## Section 303. — ROAD RECONDITIONING

### Description

**303.01** This work consists of reconditioning ditches, shoulders, roadbeds, aggregate surfaces, or the entire road. base

### Material

**303.02** Conform to the following Subsection:

Water

725.01(c)

### Construction Requirements

**303.03 Ditch Reconditioning.** Remove slide material, sediment, vegetation, and other debris from existing ditches and culvert inlets/outlets. Reshape ditches and culvert inlets/outlets to achieve positive drainage and uniform ditch width, depth, and grade. Dispose of waste at designated sites or according to Subsection 204.14.

**303.04 Shoulder Reconditioning.** Remove slide material, vegetation, and other debris from existing shoulders including shoulders in parking areas, turnouts, and other widened areas. Repair soft and unstable areas according to Subsection 204.07. Reshape shoulders to the widths and slopes shown in the plans. Dispose of waste at designated sites or according to Subsection 204.14.

**303.05 Roadbed Reconditioning.** Remove organic, deleterious, and material larger than 6 inches (150 millimeters) from the top 6 inches (150 millimeters) of subgrade. Dispose of waste according to Subsection 204.14. Repair soft and unstable areas according to Subsection 204.07. Scarify surface to a 6-inch (150-millimeter) depth. Remove irregularities and shape to a uniform surface. Finish earth surfaces to within 0.05 feet (15 millimeters) and rock surfaces to within 0.10 feet (30 millimeters) of required line, grade, and cross-section. Compact according to Subsection 204.11.

**303.06 Aggregate Surface Reconditioning.** Base Repair soft and unstable areas to the full aggregate surface depth and according to Subsection 204.07. Scarify the thickness of aggregate surfacing material or to 6 inches (150 millimeters), whichever is less. Remove irregularities and shape to a uniform surface. Finish and compact the surface according to Subsection 302.05.

**303.07 Roadway Reconditioning.** Perform applicable work described in Subsections 303.03 through 303.06. Maintain existing cross slope and crown or as shown in the plans.

**303.08 Acceptance.** See Table 303-1 for sampling, testing, and acceptance requirements.

Road reconditioning work will be evaluated under Subsections 106.02 and 106.04.

**Measurement**

**303.09** Measure the Section 303 pay items listed in the bid schedule according to Subsection 109.02 and the following as applicable:

Measure waste under Section 204.

**Payment**

**303.10** The accepted quantities will be paid at the contract price per unit of measurement for the Section 303 pay items listed in the bid schedule. Payment will be full compensation for the work prescribed in this Section. See Subsection 109.05.



**Table 303-1  
Sampling, Testing, and Acceptance Requirements**

Material or Product (Subsection)	Type of Acceptance (Subsection)	Characteristic	Category	Test Methods Specifications	Sampling Frequency	Point of Sampling	Split Sample	Reporting Time	Remarks
<b>Production</b>									
Existing roadbed material or aggregate surfacing	Measured and tested for conformance (106.04)	Classification	-	AASHTO M 145	1 per soil type	Roadbed	Yes	Before using in work	-
		Moisture-density	-	AASHTO T 180, Method D <sup>(1)</sup> or AASHTO T 99, Method C <sup>(1)</sup>	1 per mixture or change in material	Processed material	No	"	-
		Density	-	AASHTO T 310 or other approved procedures	1 per 2000 yd <sup>2</sup> (1700 m <sup>2</sup> )	In-place after compaction	"	End of shift	For Subsection 204.11(c) cases only
	Process control (153.03)	Moisture content (in-place)	-	"	"	"	"	"	-
<b>Finished Product</b>									
Aggregate surface reconditioning (303.06)	Measured and tested for conformance (106.04)	Surface tolerance & grade	-	Subsection 301.06	Determine by the CO	Surface of final course	No	Before placement of next layer or as requested	-

(1) Minimum of 5 points per proctor.

## Section 304. — FULL DEPTH RECLAMATION

### Description

**304.01** This work consists of pulverizing an existing pavement and base in-place, adding crushed aggregate if required, mixing this material with water, and shaping and compacting the mix to produce a base.

### Material

**304.02** Conform to the following Subsections:

Crushed aggregate

703.06

Water

725.01(c)

### Construction Requirements

**304.03 General.** Establish profile and cross slope control. Maintain the existing cross slope or crown if none is established.

Before pulverizing, remove and dispose of unsuitable material as directed by the CO. Replace unsuitable material with crushed aggregate according to Subsection 304.04.

Protect manholes, valve covers, and other buried facilities from damage.

**304.04 Adding Crushed Aggregate.** If required, add crushed aggregate to bring the finished surface to the established line, grade, and cross-section.

**304.05 Pulverizing.** Furnish a road reclaimer that is:

- (a) Self-propelled;
- (b) Specifically manufactured for in-place reclamation;
- (c) Capable of reducing the existing material to the required size;
- (d) Equipped with at least an 8-foot (2.4-meter) cutting width;
- (e) Equipped with standard automatic depth controls adjustable in increments of ½ inch (13 millimeters); and
- (f) Equipped with sufficient horsepower to constantly pulverize to the required depth in a single pass.

Use the reclaimer to pulverize the existing roadway material, in-place until 100 percent passes the 2-inch (50-millimeter) sieve. Reprocess or remove larger particles and dispose of them according to Subsection 203.05.

**304.06 Mixing and Spreading.** Add water as necessary to adjust the moisture content of the mixture to within 2 percent of the optimum for compaction. Mix to produce a homogenous full depth mixture. Spread the mixture uniformly across the existing roadbed to provide a final compacted shape according to the established line, grade, and cross-section.

**304.07 Compacting.** Compact using one of the following methods:

(a) **Method 1.** Compact material full width according to Subsection 204.11(a).

(b) **Method 2.** Compact material according to Subsection 301.05.

**304.08 Surface Tolerance.** See Subsection 301.06.

**304.09 Maintenance.** See Subsection 301.07. Overlay the base within 14 days after compacting.

**304.10 Acceptance.** See Table 304-1 for sampling, testing, and acceptance requirements.

Crushed aggregate will be evaluated under Subsection 106.03.

Construction of full depth reclamation will be evaluated under Subsections 106.02 and 106.04.

### **Measurement**

**304.11** Measure the Section 304 pay items listed in the bid schedule according to Subsection 109.02 and the following as applicable.

Measure crushed aggregate under Section 302.

Measure removal and disposal of unsuitable material under Sections 203 and 204.

### **Payment**

**304.12** The accepted quantities will be paid at the contract price per unit of measurement for the Section 304 pay items listed in the bid schedule. Payment will be full compensation for the work prescribed in this Section. See Subsection 109.05.

**Table 304-1  
Sampling, Testing, and Acceptance Requirements**

Material or Product (Subsection)	Type of Acceptance (Subsection)	Characteristic	Category	Test Methods Specifications	Sampling Frequency	Point of Sampling	Split Sample	Reporting Time	Remarks
<b>Production</b>									
Pulverized material	Measured and tested for conformance (106.04)	Moisture-density	-	AASHTO T 180, Method D <sup>(1)</sup>	1 per change in material	Behind reclaimer before compaction	Yes	Before using in work	-
		Density	-	AASHTO T 310	1 per 2,000 yd <sup>2</sup> (1,700 m <sup>2</sup> )	In-place after compaction	No	End of shift	For Method 2 compaction only
	Process control (153.03)	Moisture content (in-place)	-	AASHTO T 255 or other approved methods	Minimum 1 per 3500 yd <sup>2</sup> (3000 m <sup>2</sup> )	"	"	Upon completion of test	-
		Gradation	-	AASHTO T 27	"	Behind reclaimer before compaction	"	"	Minus 2-inch (50-mm) sieve requirement only
<b>Finished Product</b>									
Finished pulverized material	Measured and tested for conformance (106.04)	Surface tolerance & grade	-	Subsection 301.06	Determined by the CO	Completed FDR surface	No	Before placement of next layer or as requested	-

(1) Minimum of 5 points per proctor.

## Section 406. — FOG SEAL

### Description

**406.01** This work consists of applying an emulsified asphalt fog seal.

Emulsified asphalt is designated according to AASHTO M 140 or AASHTO M 208.

### Material

**406.02** Conform to the following Subsections:

Blotter	703.12
Emulsified asphalt	702.02
Water	725.01(c)

### Construction Requirements

**406.03 Equipment.** Furnish an asphalt distributor with the following:

- (a) Heater for uniformly heating the asphalt;
- (b) Full circulation spray bar adjustable to 15-foot (4.5-meter) width;
- (c) Positive controls including tachometer, pressure gauge, volume measuring device, or calibrated tank to uniformly deposit asphalt over the full width within 0.02 gallons per square yard (0.09 liters per square meter) of the required rate; and
- (d) Thermometer for measuring asphalt temperature in the tank.

**406.04 Surface Preparation.**

- (a) Clean the existing surface of loose material, dirt, and other deleterious material before placing the fog seal. Remove or protect raised pavement markers, pavement markings, reflectorized tape, and other material that interferes with the work. Protect service entrances (such as manholes, valve boxes, and drop inlets). Protect concrete work, rock walls, and other objects adjacent to the work.
- (b) Dry the surface before placing the fog seal.

**406.05 Weather Limitations.** Apply fog seals only when the following apply:

- (a) Ambient air temperature is above 50 °F (10 °C);
- (b) Surface temperature is above 50 °F (10 °C);
- (c) Weather is not foggy or rainy;
- (d) Rain or temperatures below 40 °F (4 °C) are not anticipated for at least 24 hours after application;



(e) Sustained winds are less than or equal to 10 miles (16 kilometers) per hour; and

(f) Application is completed at least 2 hours before sunset.

**406.06 Asphalt Application.** Dilute the emulsion one part water to one part emulsified asphalt.

Apply the emulsion according to Subsection 407.09 at a rate of 0.10 to 0.15 gallons per square yard (0.4 to 0.7 liters per square meter) as approved by the CO.

At locations where the fog seal cannot be applied with an asphalt distributor spray bar, apply the fog seal uniformly using a hand spray attachment or by another approved method.

Allow the fog seal to cure undisturbed for at least 2 hours or until the emulsified asphalt breaks and is substantially tack free.

Cover unabsorbed asphalt with blotter to protect traffic or minimize rain damage. Remove excess blotter after the asphalt is absorbed. Dispose of material according to Subsection 203.05(a) and (d).

**406.07 Acceptance.** See Table 406-1 for sampling, testing, and acceptance requirements.

Emulsified asphalt will be evaluated under Subsections 106.02 and 106.03. Furnish a production certification with each load of emulsified asphalt.

Blotter will be evaluated under Subsection 106.03.

Construction of fog seals will be evaluated under Subsections 106.02 and 106.04.

### **Measurement**

**406.08** Measure the Section 406 pay items listed in the bid schedule according to Subsection 109.02 and the following as applicable:

Measure fog seal including water added for dilution. Show a breakdown of total emulsion and water added on the load invoices supplied to the CO for payment.

### **Payment**

**406.09** The accepted quantities will be paid at the contract price per unit of measurement for the Section 406 pay items listed in the bid schedule. Payment will be full compensation for the work prescribed in this Section. See Subsection 109.05.

**Table 406-1  
Sampling, Testing, and Acceptance Requirements**

<b>Material or Product (Subsection)</b>	<b>Type of Acceptance (Subsection)</b>	<b>Characteristic</b>	<b>Category</b>	<b>Test Methods Specifications</b>	<b>Sampling Frequency</b>	<b>Point of Sampling</b>	<b>Split Sample</b>	<b>Reporting Time</b>	<b>Remarks</b>
<b>Production</b>									
Emulsified asphalt (702.02)	Process control (153.03)	Placement temperature	-	-	Minimum 1 per distributor truck	Distributor truck	No	Before incorporating into work	-

## Section 407. — CHIP SEAL

### Description

**407.01** This work consists of applying a single or double course chip seal.

Chip seal types are designated according to Tables 407-1 and 407-2.

Asphalt binder is designated according to AASHTO M 320 and emulsified asphalt is designated according to AASHTO M 140 or AASHTO M 208.

### Material

**407.02** Conform to the following Section and Subsections:

Asphalt binder	702.01
Blotter	703.12
Chip seal aggregate	703.09
Emulsified asphalt	702.02
Fog seal	406

### Construction Requirements

**407.03 Qualifications.** Provide a superintendent and foreman with experience in placing chip seals. Submit the following for approval at least 14 days before starting chip seal work:

- (a) Names of personnel; and
- (b) A résumé for each individual describing their experience on at least five chip seal projects of similar complexity.

**407.04 Composition.** Submit the following for approval at least 14 days before placement:

- (a) **Aggregate samples.** 80 pounds (35 kilograms) from the material produced for the project, the gradation range represented, and the proposed target value for each sieve size;
- (b) **Asphalt sample.** 1-gallon (4-liter) sample with a production certification conforming to Subsection 106.03(a);
- (c) **Spread rates.** The proposed spread rate for the asphalt and aggregate; and
- (d) **Density.** The density of the aggregate according to AASHTO T 19, shoveling procedure.

**407.05 Equipment.**

- (a) **Asphalt distributor.** See Subsection 406.03. Maintain two-way radio communication with the aggregate spreader.
- (b) **Sweeper.** Furnish two sweepers conforming to Subsection 409.05(c).

**(c) Pneumatic-tire rollers.**

- (1) Three rollers each with a minimum compacting width of 5 feet (1.5 meters), or two rollers each with a minimum compacting width of 6.5 feet (2.0 meters); and
- (2) Gross mass adjustable within the range of 200 to 360 pounds per inch (3.6 to 6.4 kilograms per millimeter) of compaction width.

**(d) Aggregate spreader.** Controls to uniformly deposit aggregate over the full asphalt width.

**407.06 Surface Preparation.** See Subsection 406.04(a). Prepare the surface as follows:

- (a) Newly asphalt patched areas.** Fog seal according to Section 406.
- (b) Existing asphalt surfaces including recycled asphalt pavements.** Dry the surface.
- (c) Aggregate base course surfaces.**
  - (1) When using an emulsified asphalt, make the surface damp; or
  - (2) When using an asphalt binder, dry the surface.

**407.07 Weather Limitations.** Apply chip seals only when the following apply:

- (a)** Ambient air temperature is above 65 °F (18 °C);
- (b)** Surface temperature in the shade is above 60 °F (16 °C);
- (c)** Surface temperature in the sun is below 150 °F (66 °C);
- (d)** Weather is not foggy or rainy;
- (e)** Rain or temperatures below 40 °F (4 °C) are not anticipated for at least 24 hours after application;
- (f)** Sustained winds are less than or equal to 10 miles (16 kilometers) per hour; and
- (g)** Application is completed at least 2 hours before sunset.

**407.08 Production Start-Up Procedures.** Conduct a pre-chip seal preparatory phase meeting according to Subsection 153.04(a).

On the first day of each chip seal layer placement, construct up to three 200- to 500-foot (60- to 150-meter) control strips that are one-lane wide according to Subsections 407.09 and 407.10. Coordinate the control strip locations with the CO. Start the first control strip at the proposed application rates. Vary the asphalt material or surface aggregate application rate for each control strip. Construct the control strip using the material, lay-down procedures, and compaction procedures intended for the entire project.

Repeat the control strip process until an acceptable control strip is produced. Cease production until the material and the control strip are evaluated and accepted. The CO will indicate which strip will serve as the approved project control strip.

Acceptable control strips may remain in place and will be accepted as a part of the completed project. Correct unacceptable control strips.

Use these start-up procedures when changing construction procedures, when resuming production after a termination of production due to unsatisfactory quality according to Subsection 106.04, or the beginning of a new construction season.

**407.09 Asphalt Application.** Calibrate asphalt distributors before the start of project and when directed by the CO. Calibrate the spray bar height, check nozzle angle, and verify longitudinal and transverse application rates according to ASTM D2995.

Spread building paper on the pavement surface at the beginning and end of each asphalt application so distributor flow is started and stopped on the paper.

Apply asphalt uniformly at the optimum application rate determined from the control strip. Do not apply more asphalt than can immediately be covered with aggregate. Correct skipped areas or deficiencies.

At the end of each day's production, provide the CO with documentation of calibrations and application rates.

Remove and dispose of material spills and associated debris at the end of each shift according to Subsection 203.05(a) and (d).

**407.10 Aggregate Application.** When emulsified asphalt is used, verify the aggregate stockpile moisture daily and use moist surfaced aggregate.

When asphalt binder is used, dry the aggregate. Precoat the aggregate uniformly with 2 to 3 percent of residual asphalt by mass of aggregate. Maintain the flow qualities of the precoated aggregate to allow uniform spreading with the aggregate spreader.

Calibrate aggregate spreaders before the start of project and as directed by the CO. Calibrate the longitudinal and transverse spread rates.

Apply aggregate uniformly at the optimum application rate determined from the approved control strip. Apply the aggregate immediately after the asphalt material is applied. Operate the aggregate spreader so asphalt is covered with the aggregate before wheels pass over it. For part-width construction, leave an uncovered 6-inch (150-millimeter) wide asphalt strip to permit an overlap of asphalt material.

Cover excess asphalt with blotter to protect traffic.

Correct excesses and deficiencies by adding or removing aggregate to achieve a uniform texture before the asphalt cures.

Operate rollers at a maximum speed of 5 miles (8 kilometers) per hour. Do not allow the aggregate to be displaced by pickup or sticking of material to the tire surface. Roll the surface to uniformly and thoroughly bond the aggregate over the full width. Complete rolling within 1 hour after asphalt is applied to the surface. Perform three passes with the rollers. Do not allow traffic to travel over aggregate until rolling is completed.



At the end of each day's production, provide the CO with documentation for calibrations and application rates.

Use a pilot car according to Section 635 to limit traffic speeds to 10 miles (15 kilometers) per hour during the first 45 minutes after rolling and to 20 miles (30 kilometers) per hour for the next 24 hours.

Sweep the surface when the air temperature is below 90 °F (32 °C). Do not displace embedded material. Complete vacuum sweeping by the morning after construction. Dispose of material according to Subsection 203.05(a) and (d).

**407.11 Placing and Finishing.** Apply the asphalt and aggregate according to Subsections 407.09 and 407.10 and Table 407-1. The application rates in these tables are for estimating purposes only. Determine the exact rates based on approved control strips.

**Table 407-1**  
**Approximate Quantities of Material for Single Course Chip Seal**

Type	Nominal Maximum Size of Aggregate	Aggregate Gradation <sup>(1)</sup>	Estimated Quantity of Aggregate <sup>(2)</sup> pounds/yd <sup>2</sup> (kilograms/m <sup>2</sup> )	Estimated Quantity of Asphalt Binder gallons/yd <sup>2</sup> (liters/m <sup>2</sup> )	Estimated Quantity of Emulsified Asphalt gallons/yd <sup>2</sup> (liters/m <sup>2</sup> )
<b>1A</b>	¾ inch (19 mm)	A	44 – 53 (24 – 29)	0.31 – 0.42 (1.41 – 1.91)	0.48 – 0.65 (2.17 – 2.94)
<b>1B</b>	½ inch (12.5 mm)	B	29 – 33 (16 – 18)	0.25 – 0.34 (1.15 – 1.56)	0.39 – 0.53 (1.77 – 2.40)
<b>1C</b>	⅜ inch (9.5 mm)	C	24 – 28 (13 – 15)	0.18 – 0.28 (0.79 – 1.27)	0.27 – 0.43 (1.22 – 1.95)
<b>1D</b>	No. 4 (4.75 mm)	D	18 – 24 (10 – 13)	0.14 – 0.19 (0.65 – 0.85)	0.27 – 0.43 (1.22 – 1.95)

(1) See Table 703-7 for aggregate gradations.

(2) Aggregate masses are for aggregates having a bulk specific gravity of 2.65, as determined by AASHTO T 84 and AASHTO T 85. Make proportionate corrections when the aggregate furnished has a bulk specific gravity above 2.75 or below 2.55.

**407.12 Double Course Chip Seal.** Apply each asphalt and aggregate layer according to Subsections 407.09 and 407.10 and Table 407-2. Table 407-2 application rates are for estimating purposes only. Determine the exact rates based on approved control strips.

When using emulsified asphalt, wait at least 24 hours between applications. When using asphalt binder, no wait is required between applications. Lightly vacuum sweep the first layer to remove loose material.

**Table 407-2****Approximate Quantities of Material for Double Course Chip Seal**

Type (Thickness)	Nominal Maximum Size of Aggregate	Aggregate Gradation <sup>(1)</sup>	Estimated Quantity of Aggregate <sup>(2)</sup> pounds/yd <sup>2</sup> (kilograms/m <sup>2</sup> )	Estimated Quantity of Asphalt Binder gallons/yd <sup>2</sup> (liters/m <sup>2</sup> )	Estimated Quantity of Emulsified Asphalt gallons/yd <sup>2</sup> (liters/m <sup>2</sup> )
<b>2A (¾ inch (22 mm))</b>					
1 <sup>st</sup> Application	¾ inch (19 mm)	A	44 – 53 (24 – 29)	0.29 – 0.41 (1.31 – 1.86)	0.43 – 0.60 (1.95 – 2.72)
2 <sup>nd</sup> Application	¾ inch (9.5 mm)	C	24 – 29 (13 – 16)	0.41 – 0.46 (1.86 – 2.08)	0.60 – 0.70 (2.72 – 3.17)
<b>2B (¾ inch (19 mm))</b>					
1 <sup>st</sup> Application	½ inch (12.5 mm)	B	33 – 44 (18 – 24)	0.27 – 0.31 (1.22 – 1.40)	0.39 – 0.48 (1.77 – 2.17)
2 <sup>nd</sup> Application	¾ inch (9.5 mm)	C	22 – 26 (12 – 14)	0.29 – 0.38 (1.31 – 1.72)	0.45 – 0.58 (2.04 – 2.63)
<b>2C (½ inch (12.5 mm))</b>					
1 <sup>st</sup> Application	¾ inch (9.5 mm)	C	29 – 39 (16 – 21)	0.17 – 0.27 (0.77 – 1.22)	0.27 – 0.39 (1.22 – 1.77)
2 <sup>nd</sup> Application	No. 4 (4.75 mm)	D	13 – 18 (7 – 10)	0.27 – 0.31 (1.22 – 1.40)	0.39 – 0.48 (1.77 – 2.17)

(1) See Table 703-7 for aggregate gradations.

(2) Aggregate masses are for aggregates having a bulk specific gravity of 2.65, as determined by AASHTO T 84 and AASHTO T 85. Make proportionate corrections when the aggregate furnished has a bulk specific gravity above 2.75 or below 2.55.

**407.13 Acceptance.** See Table 407-3 for sampling, testing, and acceptance requirements.

Emulsified asphalt and asphalt binder will be evaluated under Subsections 106.03 and 106.04. Furnish a production certification with each load of emulsified asphalt or asphalt binder.

Chip seal aggregate gradation will be evaluated under Subsection 106.05.

The upper and lower specification limits are equal to the calculated mean of all test results plus or minus the allowable deviations shown in Table 703-7, except as follows:

- (a) If the calculated mean value for a tested sieve exceeds the maximum gradation value shown in Table 703-7, the upper specification is equal to the maximum gradation value plus the allowable deviation, and the lower specification is equal to the maximum gradation value minus the allowable deviation.

(b) If the calculated mean value for a tested sieve is less than the minimum gradation value shown in Table 703-7, the upper specification is equal to the minimum gradation value plus the allowable deviation, and the lower specification is equal to the minimum gradation value minus the allowable deviation.

Construction of asphalt chip seals will be evaluated under Subsections 106.02 and 106.04.

### Measurement

**407.14** Measure the Section 407 pay items listed in the bid schedule according to Subsection 109.02.

### Payment

**407.15** The accepted quantities will be paid at the contract price per unit of measurement for the Section 407 pay items listed in the bid schedule, except the chip seal contract price will be adjusted according to Subsection 106.05. Payment will be full compensation for the work prescribed in this Section. See Subsection 109.05.

Payment for the chip seal will be made at a price determined by multiplying the contract price by the material pay factor. The material pay factor is the lowest single pay factor determined for each specified sieve of the aggregate gradation for each aggregate gradation furnished.

When two gradations are furnished for a double chip seal the material pay factor is weighted for the quantity of each aggregate gradation spread as a percent of the total. The material pay factor is calculated as follows:

$$PF_{\text{Material}} = PF_{1\text{st}}[SR_{1\text{st}}/(SR_{1\text{st}} + SR_{2\text{nd}})] + PF_{2\text{nd}}[SR_{2\text{nd}}/(SR_{1\text{st}} + SR_{2\text{nd}})]$$

where:

$PF_{\text{Material}}$  = Material pay factor.

$PF_{1\text{st}}$  = Pay factor for first aggregate gradation.  $PF_{1\text{st}}$  is the lowest single pay factor determined for each specified sieve.

$PF_{2\text{nd}}$  = Pay factor for second aggregate gradation.  $PF_{2\text{nd}}$  is the lowest single pay factor determined for each specified sieve.

$SR_{1\text{st}}$  = Spread rate for the first aggregate per square yard (square meter).

$SR_{2\text{nd}}$  = Spread rate for the second aggregate per square yard (square meter).

**Table 407-3  
Sampling, Testing, and Acceptance Requirements**

Material or Product (Subsection)	Type of Acceptance (Subsection) <sup>(3)</sup>	Characteristic	Category	Test Methods Specifications	Sampling Frequency	Point of Sampling	Split Sample	Reporting Time	Remarks
<b>Source</b>									
Chip seal aggregate <sup>(1)</sup>	Measured and tested for conformance (106.04 & 105)	Quality	-	Subsection 703.09	1 per material type	Source of material	Yes	Before producing	-
	Process control (153.03)	Gradation	-	AASHTO T 27 & T 11	2 per day per stockpile	Crusher belt (during production)	No	24 hours	Not required when using a pre-crushed commercial source
Blotter	"	"	-	Subsection 703.12	"	"	"	"	-
Asphalt binder <sup>(2)</sup> or emulsified asphalt <sup>(2)</sup>	Measured and tested for conformance (106.04)	Quality	-	Section 702	1 per material type	Point of shipment or delivery	Yes <sup>(5)</sup>	Before incorporating into work	-

**Table 407-3 (continued)  
Sampling, Testing, and Acceptance Requirements**

Material or Product (Subsection)	Type of Acceptance (Subsection) <sup>(3)</sup>	Characteristic	Category	Test Methods Specifications	Sampling Frequency	Point of Sampling	Split Sample	Reporting Time	Remarks
<b>Production</b>									
Chip seal aggregate <sup>(1)</sup>	Statistical <sup>(3)</sup> (106.05)	Gradation (See Table 703-7 for applicable sieves)	1	AASHTO T 27 & T 11	See Note (3)	Production belt or spreader discharge <sup>(4)</sup>	Yes	24 hours	–
	Process control (153.03)	Moisture on surface of aggregates	–	Visual inspection (409.10)	Contractor determine	Stockpile or spreader discharge	No	Before incorporating into work	–
Asphalt binder <sup>(2)</sup> or emulsified asphalt <sup>(2)</sup>	Measured and tested for conformance (106.04)	Quality	–	Section 702	1 per tanker truck including trailer	Tanker or Distributor	Yes <sup>(5)</sup>	–	Tested by Government
	Process control (153.03)	Placement temperature	–	–	Minimum 1 per distributor truck	Distributor truck	No	Before incorporating into work	–

(1) Applies to each aggregate grade furnished.

(2) Applies to each asphalt material furnished.

(3) For plan quantities less than 40,000 square yards (33,000 square meters), material will be accepted according to Subsection 106.03. For plan quantities greater than 40,000 square yards (33,000 square meters), material will be accepted according to Subsection 106.05. For plan quantities between 40,000 and 240,000 square yards (33,000 and 200,000 square meters), the sampling frequency will be determined by dividing the plan quantity by eight. If plan quantity exceeds 240,000 square yards (200,000 square meters), the sampling frequency will be one every 30,000 square yards (25,000 square meters).

(4) Select one point of sampling that must remain throughout project or lot.

(5) Two 1-quart (1-liter) samples for asphalt binder. One 1-gallon (4-liter) sample for emulsified asphalt.

## **Section 607. — CLEANING, RELAYING, AND REPAIRING EXISTING DRAINAGE STRUCTURES**

### **Description**

**607.01** This work consists of cleaning, relaying, and repairing existing drainage and appurtenant structures.

### **Construction Requirements**

**607.02 Cleaning Drainage Structures in Place.** Remove foreign material within the structure and accessories by approved methods.

Remove debris, vegetation, and earthen material that impedes inlet and outlet channel flow to the structure. Obtain approval from the CO before removing trees.

Dispose of removed material according to Subsection 203.05.

Regrade inlet and outlet channels at structures to provide positive drainage. Reshape inlet to direct flow into the structure entrance.

**607.03 Relaying or Stockpiling Salvaged Pipe.** Relay removed and cleaned pipe according to Section 602.

Salvage and stockpile pipe according to Subsection 203.03.

Replace damaged pipe and install according to Section 602. Dispose of damaged pipe according to Subsection 203.05(a).

**607.04 Repairing Drainage Structures.** Remove debris from structures designated to be repaired. Repair leaks and structural damage and replace missing or broken metalwork according to Sections 602 and 603.

**607.05 Acceptance.** Cleaning and repairing existing drainage structures will be evaluated under Subsection 106.02.

Relaying pipe will be evaluated under Section 602.

### **Measurement**

**607.06** Measure the Section 607 pay items listed in the bid schedule according to Subsection 109.02.

### **Payment**

**607.07** The accepted quantities will be paid at the contract price per unit of measurement for the Section 607 pay items listed in the bid schedule. Payment will be full compensation for the work prescribed in this Section. See Subsection 109.05.

## Section 633. — PERMANENT TRAFFIC CONTROL

### Description

**633.01** This work consists of installing and removing and resetting permanent traffic control devices.

Sign panels are designated as plywood, steel, aluminum, plastic, fiberglass reinforced plastic, or extruded aluminum.

Sign posts are designated as wood, aluminum, galvanized steel, or corrosion resistant steel.

### Material

**633.02** Conform to the MUTCD and the following Section and Subsections:

Delineator and object marker retroreflectors	718.08
Hardware	718.06
Legends and borders	718.07
Minor concrete	601
Object marker and delineator posts	718.05
Panels	718.03
Retroreflective sheeting	718.01
Sign posts	718.04

### Construction Requirements

**633.03 General.** Furnish and install permanent traffic control devices according to the MUTCD and permanent traffic control plans. Provide traffic control devices that are crashworthy.

Sign locations may be changed to fit field conditions as approved by the CO. Determine sign support lengths at time of staking.

**633.04 Sign Posts.** Install sign posts plumb and according to the manufacturer's recommendations.

Drive sign posts with a suitable driving head or set posts in drilled or punched holes.

Excavate, construct, and backfill concrete footings according to Section 601.

**633.05 Sign Panels.**

#### (a) Fabrication.

**(1) Panels.** Cut panels to dimension shown and place holes before applying retroreflective material. Do not field drill holes in panels.

Clean and degrease the face of the metal panels using methods recommended by the retroreflective sheeting manufacturer before applying retroreflective sheeting.

Wipe plastic panels clean with a slightly dampened cloth before applying retroreflective sheeting.



Abrade, clean, and degrease the face of the plywood panels using methods recommended by the retroreflective sheeting manufacturer before applying reflective sheeting. Treat plywood panel edges with sealant.

Join extruded aluminum panel sections with panel nuts, bolts, and washers to achieve the desired sign size. Use 6- and 12-inch (150- and 300-millimeter) plate heights to achieve the sign panel vertical dimensions in increments of 6 inches (150 millimeters). Do not include more than one 6-inch (150-millimeter) plate per sign.

Use retroreflective sheeting as specified and according to ASTM D4956. For roadside signs, use Type III, IV, VIII, IX, or XI prismatic retroreflective sheeting. Use fluorescent yellow sheeting for warning signs. Use fluorescent yellow-green sheeting for pedestrian, bicycle, and school crossing signs.

For multilane or overhead guide signs, use Type III or Type IV prismatic retroreflective sheeting for the background and Type IX or Type XI retroreflective sheeting for the legend.

For parking lot and non-roadway signs, Types I and Type II retroreflective sheeting may be used.

**(2) Legends and borders.** Form letters, numerals, and other units to provide a continuous stroke width with smooth edges. Make the surface flat and free of warp, blisters, wrinkles, burrs, and splinters. Do not fabricate letters, numerals, arrows, symbols, or borders using a red screen ink process.

Conform to one of the following techniques:

*(a) Type L-1 (screen process).* Apply letters, numerals, arrows, symbols, borders, and other features on the sign background by direct or reverse screen process. Apply messages and borders of a color darker than the sign background by the direct process. Apply messages and borders of a color lighter than the sign background by the reverse screen process.

Apply screen inks recommended by the ink manufacturer for use on the various types of retroreflective sheeting. Apply ink that has the same durability and color as specified for that type of retroreflective sheeting. Apply black screen ink until opaque on retroreflective sheeting.

Perform the screening in a manner to ensure a uniform color and tone, with sharply defined edges of legends and borders. Do not allow running, streaking, or sagging.

Air dry or bake the signs after screening according to manufacturer's recommendations to provide a smooth hard finish.

*(b) Type L-2 (transparent films).* Apply letters, numerals, arrows, symbols, borders, and other features on the sign background with colored transparent films. Select durable, electronically cuttable films coated with a transparent pressure-sensitive adhesive protected by a removable liner. Use transparent films recommended by the manufacturer within the color requirements specified for the retroreflective sheeting.

*(c) Type L-3 (direct applied characters).* Cut letters, numerals, arrows, symbols, borders, and other features from black opaque or retroreflective sheeting of the color specified. Apply characters to the sign background according to the retroreflective sheeting manufacturer's instructions. Use the same sheeting manufacturer for both the sign legend, border, and background.

Package sign panels in protective material and transport in a vertical position.

**(b) Installation.** Mount sign panels with the legend horizontal.

Use oversized bolt heads and neoprene or nylon washers for fastening plastic sign panels. Use antitheft fasteners where possible. Paint bolt heads, screw heads, and washers that are exposed on the sign face. Match the color of the paint to the color of the sheeting at the point where the fitting is exposed.

Turn sign panels 3 degrees away from the road in the direction of travel to reduce specular glare (mirror reflection).

Cover the sign face with an opaque material if a sign message is not applicable. Maintain the covering in good condition until the message becomes applicable. Do not use adhesive tape on the sign face.

**633.06 Delineators and Object Markers.** Attach delineators and object markers to posts according to the manufacturer's recommendation or as specified.

**633.07 Removing and Resetting Permanent Traffic Control Devices.** Remove and store existing traffic control devices to be reset as necessary. Replace traffic control devices damaged during removal, storage, and resetting.

**633.08 Acceptance.** Material for permanent traffic control devices will be evaluated under Subsections 106.02 and 106.03.

Installation of permanent traffic control devices will be evaluated under Subsections 106.02 and 106.04.

Excavation and backfill will be evaluated under Section 209.

Minor concrete will be evaluated under Section 601.

### **Measurement**

**633.09** Measure the Section 633 pay items listed in the bid schedule according to Subsection 109.02 and the following as applicable:

When measuring sign panels by the square foot (square meter), measure front face. Measure each sign panel in a multiple configuration.

When measuring sign systems by the square foot (square meter), measure front face of each sign panel.

When measuring sign systems by the each, measure each system as one regardless of the number of sign panels.

A sign system includes the supports.

When measuring removing and resetting permanent traffic control device, measures after they are reset. Measure removing and resetting of sign systems as described above.

### **Payment**

**633.10** The accepted quantities will be paid at the contract price per unit of measurement for the Section 633 pay items listed in the bid schedule. Payment will be full compensation for the work prescribed in this Section. See Subsection 109.05.

## Section 634. — PERMANENT PAVEMENT MARKINGS

### Description

**634.01** This work consists of applying paint, markings, and markers on finished pavement.

Pavement markings are designated as follows:

- Type A – Solventborne traffic paint with Type 1 glass beads;
- Type B – Waterborne traffic paint with Type 1 glass beads;
- Type C – High-build waterborne traffic paint with Type 1 and Type 3 glass beads;
- Type D – Epoxy markings with Type 1 glass beads;
- Type E – Epoxy markings with Type 1 and Type 3 glass beads;
- Type H – Thermoplastic markings with Type 1 glass beads;
- Type I – Thermoplastic markings with Type 1 and Type 3 glass beads;
- Type J – Preformed pavement marking tape; or
- Type K – Nonreflectorized markings.

### Material

**634.02** Conform to the MUTCD and the following Subsections:

Epoxy markings	718.11
Epoxy resin adhesives	718.17
Glass beads	718.14
Pavement markers	718.15
Preformed pavement marking tape	718.13
Solventborne traffic paint	718.09
Thermoplastic markings	718.12
Waterborne traffic paint	718.10

### Construction Requirements

**634.03 General.** Where existing and final pavement marking locations are identical, stake the limits of existing pavement markings before beginning pavement work.

Submit manufacturer’s MSDS and product data sheets at least 7 days before applying pavement markings. A field demonstration may be required to verify the adequacy of the material.

Ship marking material in suitable containers plainly marked with the following information as appropriate for the material being furnished:

- (a) Manufacturer’s name and address;
- (b) Name of product;

- (c) Lot and batch numbers;
- (d) Color;
- (e) Net mass and volume of contents;
- (f) Date of manufacture;
- (g) Date of expiration;
- (h) Statement of contents (if mixing of components is required);
- (i) Mixing proportions and instructions; and
- (j) Safety information.

Establish marking patterns or locations according to the MUTCD, plans, or state requirements. In curve widening areas, establish the edge line markings at the limits of the traveled way and the centerline markings equal distance between the edge lines.

Remove loose particles, dirt, tar, grease, and other deleterious material from the surface to be marked. Where markings are placed on rigid pavement less than 1-year old, clean the pavement of laitance and curing compounds.

Remove temporary pavement markings the same day permanent pavement markings are applied. Remove temporary and conflicting pavement markings according to Subsection 635.13 before applying permanent pavement markings.

Obtain approval before applying markings. Apply markings to a clean, dry surface, and according to the manufacturer's recommendations. Produce markings that are clean-cut and uniform in appearance by day and night.

Current state approved pavement marking material may be used, when approved by the CO. Submit proof of compliance with state specifications.

Apply glass beads immediately following paint or markings application to ensure adhesion.

Protect markings from traffic until dried to a no-tracking condition. Remove tracking marks, spilled marking material, markings in unauthorized areas, and defective markings.

**634.04 Solventborne Traffic Paint (Type A).** Apply paint when pavement and air temperatures are at 35 °F (2 °C) and rising. Do not heat the paint above 120 °F (49 °C). Spray paint at a 15 mil (0.38 millimeters) minimum wet film thickness or at a rate of 107 square feet per gallon (2.6 square meters per liter).

Apply Type 1 glass beads on the paint at a rate of 6 to 8 pounds per gallon (0.72 to 0.96 kilograms per liter) of paint.

On new asphalt pavements or new asphalt surface treatments, apply two applications of paint and glass beads. Apply second application after first application is track free.

**634.05 Waterborne Traffic Paint (Type B and Type C).** Apply paint when pavement and air temperatures are 50 °F (10 °C) and rising.

(a) **Type B.** Do not heat the paint above 120 °F (49 °C). Spray paint at a 15 mil (0.38 millimeters) minimum wet film thickness or at a rate of 107 square feet per gallon (2.6 square meters per liter).

Apply Type 1 glass beads on the paint at a rate of 6 to 8 pounds per gallon (0.72 to 0.96 kilograms per liter) of paint.

On new asphalt pavements or new asphalt surface treatments, apply two coats.

(b) **Type C.** Spray paint at 25 mil (0.63 millimeters) minimum wet film thickness or at a rate of 71 square feet per gallon (1.7 square meters per liter).

Use two bead dispensers. Apply Type 3 glass beads on the paint at a rate of 6 to 8 pounds per gallon (0.72 to 0.960 kilograms per liter) followed by Type 1 glass beads on the paint at a rate of 6 to 8 pounds per gallon (0.72 to 0.96 kilograms per liter) of paint.

**634.06 Epoxy Markings (Types D and Type E).** Apply epoxy when pavement and air temperatures are 35 °F (2 °C) and rising. Heat components as specified by the manufacturer. Apply at a 25 mil (0.63 millimeters) minimum dry film thickness or at a rate of 71 square feet per gallon (1.7 square meters per liter).

(a) **Type D.** Apply Type 1 glass beads on the epoxy at a rate of 6 to 8 pounds per gallon (0.72 to 0.96 kilograms per liter) of epoxy.

(b) **Type E.** Use two bead dispensers. Apply Type 3 glass beads on the epoxy at a rate of 6 to 8 pounds per gallon (0.72 to 0.96 kilograms per liter) of epoxy followed by Type 1 glass beads on the epoxy at a rate of 6 to 8 pounds per gallon (0.72 to 0.96 kilograms per liter) of epoxy.

**634.07 Thermoplastic Markings (Type H and Type I).** Apply thermoplastic when pavement and air temperatures are 50 °F (10 °C) and rising. Heat thermoplastic as specified by the manufacturer.

Apply an epoxy resin primer/sealer according to the thermoplastic manufacturer's recommendations when placing markings on rigid pavements or asphalt pavements more than 2-years old, oxidized, or having exposed aggregates.

Allow the primer/sealer to dry.

For edge lines, apply thermoplastic at 60 mil (1.5 millimeters) dry film thickness. For other lines, apply thermoplastic at 90 mil (2.3 millimeters) dry film thickness.

(a) **Type H.** Apply Type 1 glass beads on the thermoplastic at a rate recommended by the manufacturer.

(b) **Type I.** Use two bead dispensers. Apply Type 3 glass beads on the thermoplastic followed by Type 1 glass beads on the thermoplastic at rates recommended by the manufacturer.

**634.08 Preformed Pavement Marking Tape (Type J).** Install to form a durable, weather resistant bond to the pavement. Apply preformed markings according to the manufacturer's recommendations. Use preformed marking tape containing retroreflective beads.

**634.09 Nonreflectorized Markings (Type K).** Apply solvent borne or waterborne traffic paint without glass beads.

**634.10 Pavement Markers.** Install raised or recessed pavement markers when the pavement and air temperatures are 50 °F (10 °C) and rising. Apply pavement markers with an epoxy resin adhesive as recommended by the manufacturer when the pavement is dry. Space the markers according to the MUTCD and plans.

**634.11 Acceptance.** Material for permanent pavement markings will be evaluated under Subsections 106.02 and 106.03.

Placing of permanent pavement markings will be evaluated under Subsections 106.02 and 106.04.

### **Measurement**

**634.12** Measure the Section 634 pay items listed in the bid schedule according to Subsection 109.02 and the following as applicable:

When pavement markings are measured by the linear foot (meter), measure the length of line applied along the centerline of each line applied regardless of color. Measure broken or dotted pavement lines from end to end of the line including gaps. Measure solid pavement lines from end to end of each continuous line. Measure line quantities based on a 4-inch (100-millimeter) wide line. For line widths greater than 4 inches (100 millimeters), adjust the measured length of line in the ratio of the required width to 4 inches (100 millimeters).

When pavement markings are measured by the square foot (square meter), measure the number of square feet (square meter) of line, symbol or letter marking based on the marking area shown in the plans. If not shown, measure the area of each marking in place to the nearest square foot (square meter).

### **Payment**

**634.13** The accepted quantities will be paid at the contract price per unit of measurement for the Section 634 pay items listed in the bid schedule. Payment will be full compensation for the work prescribed in this Section. See Subsection 109.05.

## Section 635. — TEMPORARY TRAFFIC CONTROL

### Description

**635.01** This work consists of furnishing, installing, maintaining, relocating, and removing temporary traffic control devices and services as ordered for the control and protection of public traffic through the project.

Advance warning arrow board, barricade, and warning light types are designated in the MUTCD.

### Material

**635.02** Conform to the MUTCD and the following Sections and Subsections:

Concrete barrier (temporary)	618
Delineator and object marker retroreflectors	718.08(b)
Guardrail (temporary)	617
Retroreflective sheeting	718.01
Sign panels	633.05
Sign posts	633.04
Temporary plastic fence	710.11
Temporary pavement markings	718.16

### Construction Requirements

**635.03 Qualifications.** Provide flaggers certified by ATSSA, the National Safety Council, a state department of transportation, or other acceptable organization. Use pilot car operators conforming to the qualifications of a flagger.

**635.04 General.** Furnish, install, and maintain temporary traffic control devices adjacent to and within the project as required by the MUTCD, traffic control plan, and Section 156. Install and maintain traffic control devices as follows:

- (a) Furnish and install traffic control devices before the start of construction operations;
- (b) Install only those traffic control devices needed for each stage or phase;
- (c) Relocate temporary traffic control devices as necessary;
- (d) Remove devices that no longer apply to the existing conditions;
- (e) Immediately replace devices that are lost, stolen, destroyed, or inoperative;
- (f) Keep temporary traffic control devices clean;
- (g) Furnish and maintain traffic control devices that meet the "acceptable" standard described in ATSSA, *Quality Standards for Work Zone Traffic Control Devices*. Amend the ATSSA standards as follows:
  - (1) Repair or remove and replace "marginal" devices within 48 hours; and



- (2) Repair or remove and replace "*unacceptable*" devices immediately;
- (h) Remove temporary traffic control devices upon contract completion or when approved; and
- (i) Furnish crashworthy temporary traffic control devices.

**635.05 Barricades.** Use barricades of the type and size specified or according to the MUTCD. Use Type III, IV, IX, or XI retroreflective sheeting.

**635.06 Cones and Tubular Markers.** Use cones or tubular markers of the height specified or according to the MUTCD. Use Type III or Type VI retroreflective sheeting.

**635.07 Construction Signs.** Use Type III, IV, VIII, IX, or XI prismatic retroreflective sheeting. Use fluorescent sheeting for orange signs. For roll-up signs, use fluorescent Type VI retroreflective sheeting.

Install posts according to Section 633. Portable sign supports may be used instead of sign posts when approved by the CO.

Remove or completely cover unnecessary signs. Use metal, plywood, or other acceptable material to cover signs. Do not use adhesives glues, tapes, or mechanical fasteners that mar the face of the panel of the sign to be covered.

**635.08 Drums.** Use plastic drums that are at least 36 inches (900 millimeters) high and at least 18 inches (450 millimeters) in diameter. Use Type III or Type VI retroreflective sheeting.

**635.09 Flaggers.** Use flaggers certified according to Subsection 635.03. Use Type III, IV, VIII, IX, or XI retroreflective sheeting on flagger paddles. Do not use flags.

**635.10 Pilot Cars.** Use pilot car operators certified according to Subsection 635.03. Mount a "*PILOT CAR FOLLOW ME*" sign on the rear and a high-intensity, rotating, flashing, oscillating, or strobe light on the roof of the pilot car.

**635.11 Temporary Barriers.** Use temporary barriers that are crashworthy and are new or used provided they are not badly damaged. Lifting holes no larger than 4 inches (100 millimeters) or lifting loops are permitted.

Mount white or yellow retroreflectors as applicable, to the top or side of the barrier on 25-foot (8-meter) centers. Mount the retroreflectors at a uniform height at least 24 inches (600 millimeters) above the road surface. Flexible barrier delineators or barrier delineation tape may be used instead of retroreflectors when approved by the CO.

**635.12 Temporary Guardrail.** Construct temporary guardrail according to Section 617.

Mount white or yellow retroreflectors as applicable, to the top or side of the guardrail on 25-foot (8-meter) centers. Mount the retroreflectors at a uniform height at least 24 inches (600 millimeters) above the road surface.

**635.13 Temporary Pavement Markings and Delineation.** Before opening a pavement surface to traffic, remove conflicting pavement markings by sandblasting or other methods that do not damage the surface or texture of the pavement. Make the removal pattern uneven to not perpetuate the outline of the removed pavement markings. Lightly coat sandblasted or removal areas on asphalt surfaces with emulsified asphalt.

Place and maintain temporary pavement markings that are neat, crack free, true, straight, and unbroken.

If temporary signs and pavement markers are substituted for temporary pavement markings, install temporary signs and pavement markers according to the MUTCD and plans.

For temporary pavement markings, use preformed retroreflective tape, traffic paint, or pavement markers as follows:

**(a) Preformed retroreflective tape.** Apply according to the manufacturer's instructions. Remove loose preformed retroreflective tape before placing additional pavement layers.

**(b) Pavement markers.** Do not use pavement markers during seasonal suspensions. When chip seals, slurry seals, or tack coats are used after marker placement, protect the markers with an approved protective cover, and remove it after the asphalt material is sprayed.

**(c) Traffic paint.** Do not apply traffic paint to the final surface. Apply traffic paint as the temporary pavement marking if no work will be performed on the project for at least 30 consecutive days. Apply traffic paint at a 15 mil (0.38-millimeter) minimum wet film thickness or at a rate of 107 square feet per gallon (2.6 square meters per liter). Immediately apply Type 1 glass beads on the paint at a minimum rate of 6 pounds per gallon (0.7 kilograms per liter) of paint.

Remove temporary pavement markers before placing additional pavement layers or permanent pavement markings. Remove temporary markings after 14 days and apply permanent pavement markings unless approved by the CO.

**635.14 Vertical Panels.** Use vertical panels that are at least 24 inches (600 millimeters) in height and 8 to 12 inches (200 to 300 millimeters) wide. Use Type III, IV, VIII, IX, or XI retroreflective sheeting.

**635.15 Warning Lights.** Use warning lights of the types shown in the plans or according to the MUTCD. Install warning lights with a minimum mounting height of 30 inches (750 millimeter) to the bottom of the lens. Secure lights to the top of the traffic control device they are supplementing. Use batteries recommended by the light manufacturer. Mount large batteries below windshield height and preferably on the ground. Replace batteries when they no longer provide satisfactory performance.

Use Type C steady-burn warning lights for delineation on barricades or drums. Use Type A low-intensity flashing warning lights on the first 2 barricades or drums in the merging or shifting taper series. Use Type B high-intensity flashing warning lights on the first two advance warning signs. Type A and Type C warning lights are intended to warn road users during nighttime hours, while Type B warning lights are intended to warn road users during both daylight and nighttime hours.

**635.16 Shadow Vehicle.** Use a 19,800 pound (9000-kilogram)  $\pm$  990 pound ( $\pm$ 450 kilogram) shadow vehicle equipped with a truck-mounted attenuator (crash cushion) attached to the rear of the vehicle, exterior flashing yellow dome light, and an arrow board.

Use the shadow vehicle to provide physical protection to workers from traffic approaching from the rear during moving operations.

Use the following procedures to close a lane of traffic:

- (a) Move the shadow vehicle to a point approximately 200 feet (60 meters) from the first advance warning sign for the lane closure and stop on the shoulder;
- (b) Activate the flashing lights and flashing arrow board. Begin the arrow board in the caution mode and after approximately 2 minutes display the correct flashing pass arrow;
- (c) Move the shadow vehicle (now acting as a protection vehicle) along the shoulder to the first sign location, stopping approximately 100 feet (30 meters) before the sign location in a blocking position;
- (d) Place the first sign then proceed to the next advance sign location. Repeat step (c) for the second sign and install that sign. Repeat this procedure until advance warning signs are installed;
- (e) After installing the advanced warning signs for the lane closure, move the shadow vehicle into the lane that is to be closed to a position 100 feet (30 meters) before the closing taper location. Install the channelizing devices for the taper in the shielded lane; then
- (f) Move the shadow vehicle off the roadway and past the taper on the shoulder and remain in position until the flashing arrow board for the closure (if one is to be provided) is placed and operating. Move the shadow vehicle with the workers as they proceed to set up the remaining devices as additional protection.

Alternate lane closure procedures may be used if approved by the CO.

**635.17 Pavement Patch.** Use an asphalt mix according to Section 403 or commercial available cold asphalt mix to repair potholes and rough spots in the traveled way before reopening travel lanes to traffic. If cold asphalt mix is used, remove and replace with hot asphalt mix before placing succeeding hot asphalt lifts.

**635.18 Temporary Crash Cushions.** Use a crashworthy temporary crash cushion according to manufacturer's recommendations.

**635.19 Temporary Signal System.** Use a temporary signal system according to MUTCD Parts 4 and 6.

Provide the names and telephone numbers of at least two emergency contacts who can be reached 24 hours a day, and who are available to arrive on site within 4 hours of notification to repair or replace malfunctioning temporary signal equipment. In addition, provide for emergency flaggers who can be reached 24 hours a day, and who are available to perform traffic control operations within the timeframes specified below until the temporary signal system is operable.

If the traffic signal malfunctions during construction operations, immediately begin traffic control operations using flaggers until the system is returned to normal signal operation. Complete traffic signal repairs within 6 hours of the malfunction.

If the traffic signal malfunctions during a period when no construction activity is taking place, begin traffic control operations using flaggers as soon as possible, but no later than 2 hours after the initial notification. Continue temporary flagging operations until the system is returned to normal signal operation. Complete traffic signal repairs within 12 hours of notification.

No payment will be made for the use of flaggers in place of a malfunctioning or inoperable temporary signal system.

**635.20 Temporary Fence.** Use temporary fence according to Section 619.

**635.21 Temporary Rumble Strip.** Use transverse or longitudinal rumble strips according to the MUTCD Part 6 to alert drivers of an approaching flagger station or work area.

**635.22 Steel Plates.** Use 1-inch (25-millimeter) or thicker steel plates capable of safely carrying traffic. Secure the plates to the pavement to prevent movement.

**635.23 Acceptance.** Material for temporary traffic control devices will be evaluated under Subsections 106.02 and 106.03.

Vehicles for pilot cars and shadow vehicles will be evaluated under Subsections 106.02 and 106.04.

Placement of temporary traffic control devices will be evaluated under Subsections 106.02 and 106.04.

Temporary traffic control services will be evaluated under Subsections 106.02 and 106.04.

### **Measurement**

**635.24** Measure the Section 635 pay items listed in the bid schedule according to Subsection 109.02 and the following as applicable when ordered by the CO and installed.

When measuring temporary traffic control pay items, measure only one time even if relocated or replaced, except for pay items paid by the hour.

Measure barricades by the linear foot (meter) of width.

When measuring construction signs by the square foot (square meter), measure front face sign panel. Do not measure posts and temporary supports.

When there is a pay item for moving temporary barriers, do not measure movement of temporary barriers for work access or the convenience of the Contractor.

When measuring temporary pavement markings, measure only one application of pavement markings per lift. When temporary pavement markings are measured by the linear foot or mile (meter or kilometer), measure the number of linear feet or miles (meters or kilometers) of lines applied along the centerline of each 4-inch (100-millimeter) wide line applied regardless of color. Measure solid lines from end to end of each continuous line. Measure broken lines from end to end including gaps. For line widths greater than 4 inches (100 millimeters), adjust the measured length of line in the ratio of the required width to 4 inches (100 millimeters). When temporary pavement markings are measured by the square foot (square meter), measure the number of square feet (square meters) of symbols or letter markings based on the marking area shown in the plans or, if not shown, the area of each marking measured in place to the nearest square foot (square meter).

When measuring temporary pavement markers, measure only one application of pavement markings per lift, even if replaced. Measure temporary pavement markers used at the option of the Contractor instead of temporary pavement markings as equivalent temporary pavement markings and not as temporary pavement markers.

When measuring pavement marking removal, measure the actual line removed. Do not measure gaps.

When measuring temporary crash cushions, measure each entire crash cushion configuration.

When there is a pay item for moving temporary crash cushion, do not measure movement of temporary crash cushion for work access or the convenience of the Contractor.

Measure replacement barrels or cartridges for crash cushions for the barrels or cartridges damaged by public traffic.

### **Payment**

**635.25** The accepted quantities will be paid at the contract price per unit of measurement for the Section 635 pay items listed in the bid schedule. Payment will be full compensation for the work prescribed in this Section. See Subsection 109.05.

Progress payments for temporary traffic control devices will be paid as follows:

- (a) 50 percent of the pay item amount will be paid upon installation.
- (b) An additional 25 percent of the pay item amount will be paid following completion of 50 percent of the contract amount.
- (c) Payment of the remaining portion of the pay item amount will be paid when the temporary traffic control devices are removed from the project.

Progress payments for pay items paid for by the hour will be paid at 100 percent of the pay item amount when ordered by the CO and furnished.

## Section 702. — ASPHALT MATERIAL

**702.01 Asphalt Binder.** Conform to AASHTO M 226 or AASHTO M320.

**702.02 Emulsified Asphalt.** Conform to AASHTO M 140 or AASHTO M 208.

(a) **Polymer modified cationic emulsified asphalt for chip seals.** Use a solid or latex polymer added either to the asphalt binder or during the emulsification process. Conform to AASHTO M 316, except as follows:

- |   |           |
|---|-----------|
| (1) Force ratio, $f_2/f_1$ , 39.2 °F (4 °C), 5 cm/min, AASHTO T 300   | 0.3 min.  |
| (2) Elastic recovery, 77 °F (25 °C), 5 cm/min, AASHTO T 301           | 50 % min. |
| (3) CRS-2P, penetration, 77 °F (25 °C), 100 g, 5 sec,<br>AASHTO T 49  | 90 to 150 |
| (4) CRS-2hP, penetration, 77 °F (25 °C), 100 g, 5 sec,<br>AASHTO T 49 | 50 to 90  |

(b) **Polymer-modified emulsified asphalt for micro-surfacing.** Conform to ISSA A143, except use Section 6, *Emulsified Asphalt Residue by Evaporation* of AASHTO T 59 to determine percent residue.

(c) **Penetrating emulsified asphalt for prime coat.** Conform AASHTO T 59, except as modified by Table 702-1.

**Table 702-1  
Penetrating Emulsion for Prime Coat**

	Minimum	Maximum
<b>Requirements for Emulsion</b>		
Viscosity, Saybolt Furol at 122 °F (50 °C), sec	15	150
Settlement, 24-hours, %	—	1
Residue by evaporation, %	62	—
<b>Requirements for Residue</b>		
Penetration, 77 °F (25 °C), 100 g, 5 sec, AASHTO T 49	40	200
Solubility in trichloroethylene, %, AASHTO T 44	97.5	—

**702.03 Material for Dampproofing and Waterproofing Concrete and Masonry Surfaces.**

(a) **Primer.** Conform to ASTM D41 for asphalt membranes. Furnish a neoprene-based primer for use with rubberized asphalt membrane. Furnish a resin- or solvent-based primer for use with the modified bitumen membrane.

If preformed membrane sheets are used, furnish primers of a type recommended by the manufacturer.

(b) **Asphalt.** For mop coat, conform to ASTM D449, Type I or Type II.

(c) **Waterproofing fabric.** Furnish asphalt saturated fabric conforming to ASTM D173.

If preformed membrane sheet is used, furnish either the rubberized asphalt type or the modified bitumen type. The rubberized asphalt type consists of a rubberized asphalt sheet reinforced with a polyethylene film or mesh. The modified bitumen sheet type consists of a polymer modified bitumen sheet reinforced with a stitch-bonded polyester fabric or fiberglass mesh. Conform to Table 702-2 or 702-3.

**Table 702-2**  
**Preformed Membrane Sheet for Surfaces Other Than Bridge Decks**

Property	Test	Value	
		Rubberized Asphalt Type	Modified Bitumen Type
Tensile strength in machine direction	ASTM D882	20 lb/in (3.5 kN/m)	20 lb/in (3.5 kN/m)
Elongation at break in machine direction	ASTM D882	150% at 73.4 °F (23 °C)	25% at 73.4 °F (23 °C)
Pliability	ASTM D146 <sup>(1)</sup>	No cracks	No cracks
Thickness, minimum	–	60 mil (1.52 mm)	60 mil (1.52 mm)
Softening point, minimum	ASTM D36 <sup>(1)</sup>	165 °F (74 °C)	210 °F (99 °C)

(1) Base ASTM D146 on a 180-degree bend over a 4.0-inch (100-mm) mandrel at 10 °F (-12 °C).

**Table 702-3**  
**Preformed Membrane Sheet for Bridge Decks**

Property	Test	Value	
		Rubberized Asphalt Type	Modified Bitumen Type
Tensile strength in machine direction	ASTM D882	50 lb/in (8.75 kN/m)	40 lb/in (7.0 kN/m)
Elongation at break in machine direction	ASTM D882	15% at 73.4 °F (23 °C)	10% at 73.4 °F (23 °C)
Pliability	ASTM D146 <sup>(1)</sup>	No cracks	No cracks
Thickness, minimum	–	65 mils (1.65 mm)	70 mils (1.65 mm)
Softening point, minimum	ASTM D36 <sup>(1)</sup>	165 °F (74 °C)	210 °F (99 °C)

(1) Base ASTM D146 on a 180-degree bend over a 4.0-inch (100-mm) mandrel at 10 °F (-12 °C).

**(d) Mastic.** Furnish mastic consisting of a rubberized asphalt cold-applied joint sealant for use with preformed rubberized sheets. Furnish mastic consisting of a blend of bituminous and synthetic resins for use with modified bitumen sheet.

**(e) Asphalt roll roofing.** Conform to ASTM D6380, Class M, Type II.



**702.04 Asphalt Mastic.** Conform to AASHTO M 243.

**702.05 Antistrip Additive.** Conform to the following:

(a) **Type 1.** Furnish commercially produced, heat stable liquid products that when added to an asphalt have the chemical and physical properties to prevent separation of the asphalt from aggregates.

(b) **Type 2.** Furnish cement conforming to Subsection 701.01 or fly ash conforming to Subsection 725.04(a).

(c) **Type 3.** Furnish lime conforming to AASHTO M 303.

**702.06 Mineral Fiber.** Conform to the following:

(a) Fiber length ¼-in (6-mm) max. mean test value

The fiber length is determined according to the Bauer McNett fractionation.

(b) Fiber thickness 0.0002-in (5-µm) max. mean test value

The fiber diameter is determined by measuring at least 200 fibers in a phase contrast microscope.

(c) Shot content Table 702-4

**Table 702-4**  
**Mineral Fiber Shot Content<sup>(1)</sup>**

Sieve Size	Nominal Maximum Size Percent Passing
No. 60 (250 µm)	90±5
No. 230 (63 µm)	70±10

(1) Shot content is a measure of non-fibrous material. The shot content is determined on vibrating sieves. See ASTM C612 for additional information.

### Section 703. — AGGREGATE

**703.01 Fine Aggregate for Concrete.** Furnish sand conforming to AASHTO M 6, Class B, except as amended or supplemented by the following:

- |  |   |
|--|---|
| (a) Material passing No. 200 (75- $\mu$ m) sieve, AASHTO T 11  | 3.0 percent max.                                      |
| (b) Alkali-silica reactivity. Test the aggregate for alkali silica reaction and conform to one of the following (1) through (5): |   |
| (1) Alkali-silica reactivity, ASTM C1260   | $\leq$ 0.10 percent at 16 days after casting          |
| (2) Alkali-silica reactivity, ASTM C1260   | 0.11 percent to 0.20 percent at 16 days after casting |

And one of the following examinations:

- |  |  |
|--|--|
| (a) Petrographic examination of aggregates, ASTM C295, performed within 1 year from time of submittal  | Favorable report for use                     |
| (b) Petrographic examination of hardened concrete, ASTM C856, performed on ASTM C1260 specimens after test   | Favorable report for use                     |
| (3) Alkali-silica reactivity with cementitious material, ASTM C1567, performed on approved mix design mass percent combinations. Do not use lithium compounds as mitigation measures | $\leq$ 0.10 percent at 16 days after casting |
| (4) Alkali silica reaction, ASTM C1293   | $<$ 0.04 percent at 12 months                |
| (5) Alkali-silica reaction with cementitious material, ASTM C1293, performed on approved mix design mass percent combinations  | $<$ 0.04 percent at 24 months                |

For lightweight fine aggregate, conform to AASHTO M 195.

**703.02 Coarse Aggregate for Concrete.** Conform to AASHTO M 80, Class A, except as amended or supplemented by the following:

- |                                       |  |
|---------------------------------------|--|
| (a) Los Angeles abrasion, AASHTO T 96 | 40 percent max.                                |
| (b) Grading, AASHTO M 43              | All sizes, except Size Numbers 8, 89, 9, or 10 |
| (c) Alkali-silica reactivity          | See Subsection 703.01(b)                       |

For bridge decks or surface courses, do not use aggregates known to polish or carbonate aggregates containing less than 25 percent by mass of insoluble residue as determined by ASTM D3042.

For lightweight coarse aggregate, conform to AASHTO M 195.

**703.03 Granular Backfill.** Furnish aggregate for the following installations.

**(a) Underdrain pipe with geotextile.** Furnish granular backfill conforming to AASHTO M 80, Class E and AASHTO M 43, Size Number 3, 4, 5, 57, 67, or 7.

**(b) Underdrain pipe without geotextile.** Furnish granular backfill conforming to AASHTO M 6, except the soundness test is not required.

**703.04 Reserved.**

**703.05 Subbase, Base, and Surface Course Aggregate.**

**(a) General.** Furnish hard, durable particles or fragments of crushed stone, crushed slag, or crushed gravel conforming the following:

- |  |                      |
|--|----------------------|
| (1) Los Angeles abrasion, AASHTO T 96                                    | 50 percent max.      |
| (2) Soundness of aggregate using sodium sulfate, AASHTO T 104 (5 cycles) | 12 percent loss max. |
| (3) Durability index (coarse), AASHTO T 210                              | 35 min.              |
| (4) Durability index (fine), AASHTO T 210                                | 35 min.              |
| (5) Fractured faces, ASTM D5821  | 50 percent min.      |
| (6) Without organic matter and lumps or balls of clay.                   |                      |

**(b) Subbase or base aggregate.** In addition to Subsection 703.05(a), conform to the following:

- |                               |             |
|-------------------------------|-------------|
| (1) Gradation                 | Table 703-2 |
| (2) Liquid limit, AASHTO T 89 | 25 max.     |

**Table 703-2**  
**Target Value Ranges for Subbase and Base Gradation**

Sieve Size	Percent by Mass Passing Designated Sieve (AASHTO T 27 and T 11)				
	Grading Designation				
	A (Subbase)	B (Subbase)	C (Base)	D (Base)	E (Base)
2½ inch (63 mm)	100 <sup>(1)</sup>				
2 inch (50 mm)	97 – 100 <sup>(1)</sup>	100 <sup>(1)</sup>	100 <sup>(1)</sup>		
1½ inch (37.5 mm)		97 – 100 <sup>(1)</sup>			
1 inch (25 mm)	65 – 79 (6)		80 – 100 (6)	100 <sup>(1)</sup>	
¾ inch (19 mm)			64 – 94 (6)	86 – 100 (6)	100 <sup>(1)</sup>
½ inch (12.5 mm)	45 – 59 (7)				
⅜ inch (9.5 mm)			40 – 69 (6)	51 – 82 (6)	62 – 90 (6)
No. 4 (4.75 mm)	28 – 42 (6)	40 – 60 (8)	31 – 54 (6)	36 – 64 (6)	36 – 74 (6)
No. 40 (425 µm)	9 – 17 (4)			12 – 26 (4)	12 – 26 (4)
No. 200 (75 µm)	4.0 – 8.0 (3)	4.0 – 12.0 (4)	4.0 – 7.0 (3)	4.0 – 7.0 (3)	4.0 – 7.0 (3)

(1) Statistical procedures do not apply.

( ) The value in the parentheses is the allowable deviation ( $\pm$ ) from the target values.

**(c) Surface course aggregate.** In addition to Subsection 703.05(a), conform to the following:

- |   |             |
|---|-------------|
| (1) Gradation                           | Table 703-3 |
| (2) Liquid limit, AASHTO T 89, Method A | 35 max.     |
| (3) Plasticity index, AASHTO T 90       | 10 $\pm$ 3  |

Do not furnish material that contains asbestos fibers.

**Table 703-3**  
**Target Value Ranges for Surface Course Gradations**

Sieve Size	Percent by Mass Passing Designate Sieve (AASHTO T 27 & AASHTO T 11)
1 inch (25 mm)	100 <sup>(1)</sup>
½ inch (12.5 mm)	70 – 80 (5)
No. 4 (4.75 mm)	40 – 50 (7)
No. 10 (2.0 mm)	25 – 40 (6)
No. 40 (425 µm)	15 – 25 (5)
No. 200 (75 µm)	8.0 – 14.0 (4)

(1) Statistical procedures do not apply.

( ) The value in the parentheses is the allowable deviation ( $\pm$ ) from the target values.

**703.06 Crushed Aggregate.** Furnish hard, durable particles or fragments of crushed stone or gravel conforming to the size and quality requirements for crushed aggregate material normally used locally in the construction and maintenance of highways by Federal or state agencies. Furnish crushed aggregate with a maximum size of 1 inch (25 millimeters) as determined by AASHTO T 27 and AASHTO T 11. Furnish crushed aggregate uniformly graded from coarse to fine and free of organic matter, lumps or balls of clay, and other deleterious material.

**703.07 Asphalt Concrete Aggregate.** Furnish hard, durable particles or fragments of crushed stone, crushed slag, or crushed gravel conforming to the following:

- |  |                      |
|--|----------------------|
| (a) Los Angeles abrasion, AASHTO T 96  | 35 percent max.      |
| (b) Soundness of aggregate using sodium sulfate, AASHTO T 104 (5 cycles):  |                      |
| (1) Coarse aggregate   | 12 percent loss max. |
| (2) Fine aggregate   | 12 percent loss max. |
| (c) Fractured faces, ASTM D5821  | 90 percent min.      |
| (d) Fine aggregate angularity, AASHTO T 304, Method A  | 40.0 percent min.    |
| (e) Flat and elongated particles, ASTM D4791 (1:5 ratio, plus $\frac{3}{8}$ -inch (9.5-mm) sieve, calculated by mass, weighted average)  | 10 percent max.      |
| (f) Sand equivalent, AASHTO T 176, Alternative Method No. 2, Reference Method  | 45 min.              |
| (g) Gradation. Size, grade and combine the aggregate fractions in mix proportions that result in a composite blend conforming to the specified gradation. Nominal maximum size is one sieve size greater than the first sieve to retain more than 10 percent of the combined aggregate. Test according to AASHTO T 27 and AASHTO T 11. Volumetric asphalt concrete aggregate gradation. See Table 703-4. |                      |

For the surface course, do not use aggregates known to polish or carbonate aggregates containing less than 25 percent by mass of insoluble residue when tested according to ASTM D3042.

**Table 703-4  
Asphalt Concrete Aggregate Gradation**

Sieve Size	Nominal Maximum Aggregate Size – Percent Passing									
	Grading Designation									
	1 inch (25 mm)		¾ inch (19 mm)		½ inch (12.5 mm)		⅜ inch (9.5 mm)		No. 4 (4.75 mm)	
	Min.	Max.	Min.	Max.	Min.	Max.	Min.	Max.	Min.	Max.
2 inch (50 mm)										
1½ inch (37.5 mm)	100									
1 inch (25 mm)	90	100	100							
¾ inch (19 mm)	*	90	90	100	100					
½ inch (12.5 mm)	*	*	*	90	90	100	100			
⅜ inch (9.5 mm)	*	*	*	*	*	90	90	100	100	
No. 4 (4.75 mm)	*	*	*	*	*	*	*	90	95	100
No. 8 (2.36 mm)	19	45	23	49	28	58	32	67	70	80
No. 16 (1.18 mm)	*	*	*	*	*	*	*	*	*	*
No. 30 (600 µm)	*	*	*	*	*	*	*	*	*	*
No. 50 (300 µm)	*	*	*	*	*	*	*	*	*	*
No. 200 (75 µm)	1.0	7.0	2.0	8.0	2.0	10.0	2.0	10.0	4.0	10.0

\* Contractor specified target values. See Table 703-5 for allowable deviations.

**Table 703-5**  
**Allowable Deviation Based on Target Value**

Percent by Mass Passing		Allowable Deviation
Minimum	Maximum	
70.1	89.9	4
60.1	70.0	5
55.1	60.0	6
45.1	55.0	7
40.1	45.0	6
30.1	40.0	5
21.1	30.0	4
8.1	21.0	3
0	8.0	2

**703.08 Open-Graded Asphalt Friction Course Aggregate.** Furnish hard, durable particles or fragments of crushed stone, crushed slag, or crushed gravel conforming to the following:

- |  |                      |
|--|----------------------|
| (a) Los Angeles abrasion, AASHTO T 96  | 35 percent max.      |
| (b) Soundness of aggregate using sodium sulfate, AASHTO T 104 (5 cycles), coarse aggregate | 12 percent loss max. |
| (c) Fractured faces, ASTM D5821 (two or more)  | 75 percent min.      |
| (d) Gradation  | Table 703-6          |

**Table 703-6**  
**Target Value Ranges for**  
**Open Graded Friction Course Aggregate Gradation**

Sieve Size	Percent by Mass Passing Designated Sieve (AASHTO T 27 & T 11)	
	Grading Designation	
	A	B
½ inch (12.5 mm)	–	100
¾ inch (9.5 mm)	100	95 – 100
No. 4 (4.75 mm)*	30 – 45	50 – 70
No. 8 (2.36 mm)*	5 – 15	5 – 15
No. 200 (75 µm)*	2.0 – 5.0	2.0 – 5.0

\* Contractor specified target values. See Table 703-5 for allowable deviations.



**703.09 Chip Seal Aggregate.** Furnish hard durable particles or fragments of crushed gravel, crushed stone, crushed slag, or lightweight aggregates. Use only one type of aggregate on the surface treatment. Conform to the following:

- (a) Gradation Table 703-7
- (b) Clay lumps and friable particles, AASHTO T 112 1.0 percent max.
- (c) Flat and elongated particles, ASTM D4791 (1:3 ratio, plus 3/8-inch (9.5-mm) sieve, calculated by mass, weighted average) 10 percent max.
- (d) Fractured faces, ASTM D5821 90 percent min.
- (e) Los Angeles abrasion, AASHTO T 96 40 percent max.
- (f) Soundness of aggregate using sodium sulfate, AASHTO T 104 (5 cycles) 12 percent loss max.

**Table 703-7  
Target Value Ranges for  
Single and Double Course Chip Seal Aggregate Gradation**

Sieve Size	Percent by Mass Passing Designated Sieve (AASHTO T 27 & AASHTO T 11)			
	Grading Designation			
	A	B	C	D
1½ inch (37.5 mm)				
1 inch (25 mm)	100 <sup>(1)</sup>			
¾ inch (19 mm)	90 – 100 (3)	100 <sup>(1)</sup>		
½ inch (12.5 mm)	0 – 35 (5)	90 – 100 (3)	100 <sup>(1)</sup>	
⅜ inch (9.5 mm)	0 – 12 (3)	0 – 35 (5)	85 – 100 (3)	100 <sup>(1)</sup>
No. 4 (4.75 mm)	–	0 – 12 (3)	0 – 35 (5)	85 – 100 (3)
No. 8 (2.36 mm)	–	–	0 – 8 (3)	0 – 23 (4)
No. 200 (75 µm)	0.0 – 1.0 (0.5)	0.0 – 1.0 (0.5)	0.0 – 1.0 (0.5)	0.0 – 1.0 (0.5)

(1) Statistical procedures do not apply.

( ) The value in the parentheses is the allowable deviation (±) from the target values.

**703.10 Slurry Seal and Micro Surfacing Aggregate.** Furnish hard durable particles or fragments of crushed gravel or crushed stone.

(a) **Slurry seal aggregate.** Conform to ISSA A105 and the following:

- (1) Gradation Table 703-8
- (2) Los Angeles abrasion, AASHTO T 96, Grading D 35 percent max.

- (3) Sand equivalent, AASHTO T 176, Alternate Method No. 2, Reference Method 45 min.
- (4) Soundness of aggregate using sodium sulfate, AASHTO T 104 (5 cycles) 15 percent loss max.

(b) **Micro surfacing aggregate.** Conform to ISSA A143 and the following:

- (1) Gradation Table 703-8
- (2) Los Angeles abrasion, AASHTO T 96, Grading D 30 percent max.
- (3) Sand equivalent AASHTO T 176, Alternate Method No. 2, Reference Method 65 min.
- (4) Soundness of aggregate using sodium sulfate, AASHTO T 104 (5 cycles) 15 percent loss max.

**Table 703-8**  
**Micro Surfacing and Slurry Seal Aggregate**  
**Gradation**

Sieve Size	Percent by Mass Passing Designated Sieve (AASHTO T 27 & AASHTO T 11)		
	Grading Designation		
	I	II	III
$\frac{3}{8}$ inch (9.5 mm)	—	100	100
No. 4 (4.75 mm)	100	90 – 100	70 – 90
No. 8 (2.36 mm)	90 – 100	65 – 90	45 – 70
No. 16 (1.18 mm)	65 – 90	45 – 70	28 – 50
No. 30 (600 $\mu$ m)	40 – 65	30 – 50	19 – 34
No. 50 (300 $\mu$ m)	25 – 42	18 – 30	12 – 25
No. 100 (150 $\mu$ m)	15 – 30	10 – 21	7 – 18
No. 200 (75 $\mu$ m)	10.0 – 20.0	5.0 – 15.0	5.0 – 15.0

**703.11 Reserved.**

**703.12 Blotter.** Furnish sound durable particles of gravel or crushed stone conforming to the following:

- (a) Material passing  $\frac{3}{8}$ -inch (9.5-mm) sieve, AASHTO T 27 100 percent
- (b) Liquid limit, AASHTO T 89, Method A 25 max.
- (c) Without organic matter and clay balls.

**703.13 Aggregate for Aggregate-Topsoil Course.** Conform to AASHTO M 80, Class E and AASHTO M 43, Size Number 57.

**703.14 Sand.** Furnish clean material conforming to the following:

- (a) Gradation AASHTO M 6
- (b) Deleterious material AASHTO M 6, Class B

**703.15 Aggregate for Lean Concrete Backfill.** Furnish hard, clean, durable, nonplastic, nonorganic, nonreactive aggregate to meet the designated gradation in Table 703-10.

**Table 703-10**  
**Aggregate for Lean Concrete Backfill**

Sieve Size	Percent by Mass Passing Designated Sieve (AASHTO T 27 & T 11)
1 inch (25 mm)	100
No. 200 (75 $\mu$ m)	0.0 – 10.0

**703.16 Shotcrete Aggregate.** Combine fine and coarse aggregates to meet the designated gradation in Table 703-11.

**Table 703-11**  
**Shotcrete Gradation Limits for Combined Aggregates**

Sieve Size	Percent by Mass Passing Designated Sieve (AASHTO T 27 & AASHTO T 11)	
	Grading Designation	
	A	B
½ inch (12.5 mm)	—	100
¾ inch (9.5 mm)	100	90 – 100
No. 4 (4.75 mm)	95 – 100	70 – 85
No. 8 (2.36 mm)	80 – 98	50 – 70
No. 16 (1.18 mm)	50 – 85	35 – 55
No. 30 (600 $\mu$ m)	25 – 60	20 – 35
No. 50 (300 $\mu$ m)	10 – 30	8 – 20
No. 100 (150 $\mu$ m)	2.0 – 10.0	2.0 – 10.0

(a) **Fine aggregate.** Conform to AASHTO M 6, Class B, except as amended or supplemented by the following:

- (1) Material passing No. 200 (75- $\mu$ m) sieve, AASHTO T 11 3.0 percent max.
- (2) Sand equivalent value, AASHTO T 176, Alternate Method No. 2, Reference Method 75 min.
- (3) Alkali-silica reactivity See Subsection 703.01(b)

(b) **Coarse aggregate.** Conform to AASHTO M 80, Class A, except as amended or supplemented by the following:

- (1) Los Angeles abrasion, AASHTO T 96 40 percent max.

(2) Alkali-silica reactivity

See Subsection 703.01(b)

**703.17 Granular Rock Backdrain.** Furnish hard, durable rock conforming to the following:

- |   |                  |
|---|------------------|
| (a) Los Angeles abrasion, AASHTO T 96       | 50 percent max.  |
| (b) Apparent specific gravity, AASHTO T 85  | 2.50 min.        |
| (c) Absorption, AASHTO T 85                 | 4.0 percent max. |
| (d) Durability index (course), AASHTO T 210 | 50 min.          |
| (e) Gradation                               | Table 703-12     |

**Table 703-12**  
**Granular Rock Backdrain Gradation**

Sieve Size	Percent by Mass Passing Designated Sieve (AASHTO T 27 & AASHTO T 11)
6 inch (150 mm)	100
4 inch (100 mm)	0 – 25
No. 200 (75 $\mu$ m)	0.0 – 5.0

## Section 718. — TRAFFIC SIGNING AND MARKING MATERIAL

**718.01 Retroreflective Sheeting.** Conform to ASTM D4956, including supplementary requirements.

**718.02 Reserved.**

**718.03 Panels.** Conform to the following:

(a) **Plywood.** Furnish exterior Grade B-B high-density overlay plywood or better conforming to NIST Product Standard PS 1, *Construction and Industrial Plywood*. Use ½-inch (13-millimeter) thick plywood for sign panels with a facial area 4 square feet (0.4 square meters) or less and the horizontal dimension no greater than the vertical dimension. Use ¾-inch (19-millimeter) thick plywood for larger panels.

(b) **Steel.** Furnish continuous coated (galvanized) 0.079-inch (2-millimeter) sheet steel blanks conforming to ASTM A653 and zinc coating designation G90.

Furnish panels with a substantially plane surface. Do not use twisted or buckled panels.

(c) **Aluminum.** Furnish panels conforming to ASTM B209, alloy 6061-T6 or 5052-H38.

Fabricate temporary panels and permanent panels smaller or equal to 30 by 30 inches (750 by 750 millimeters) from 0.080-inch (2-millimeter) thick aluminum sheets. Fabricate larger permanent panels from 0.125-inch (3-millimeter) thick aluminum sheets.

Furnish blanks without laminations, blisters, open seams, pits, holes, or other defects that may affect their appearance or use. Select blanks with uniform thickness and are commercially flat.

(d) **Plastic.**

(1) **Non-reinforced plastic.** Furnish polycarbonate material that is ultraviolet stabilized for outdoor weathering and will accept adhesives, coatings, and retroreflective sheeting material.

Fabricate panels smaller or equal to 24 by 24 inches (600 by 600 millimeters) from 0.08-inch (2-millimeter) thick plastic blanks. Fabricate larger panels from 0.125-inch (3-millimeter) thick plastic blanks.

Furnish panels that are flat and free of buckles, warps, and other defects. Do not allow a gap between adjacent panels greater than ⅝ inch (16 millimeters) where multiple panels adjoin. Attach reinforcement stiffeners on the back of panels larger than 24 by 24 inches (600 by 600 millimeters) for rigidity and mounting on supports.

(2) **Reinforced plastic (fiberglass).** Furnish panels made from fiberglass reinforced thermoset polyester acrylic modified laminate sheets. Furnish sign panels ultraviolet stabilized for outdoor weathering ability that will accept adhesives, coatings, and retroreflective sheeting material.

Furnish sign panels free of visible cracks, pinholes, foreign inclusions, or surface wrinkles that would affect implied performance, alter the specific dimensions of the panel, or otherwise affect the sign panels serviceability.

Fabricate fiberglass reinforced panels conforming to the following mechanical and physical properties:

(a) Average tensile strength, ASTM D638	10,000 psi (69 MPa) min.
(b) Average tensile modulus, ASTM D638	1,200,000 psi (8.3 GPa) min.
(c) Average flexural strength, ASTM D790	20,000 psi (140 MPa) min.
(d) Average flexural modulus, ASTM D790	1,200,000 psi (8.3 GPa) min.
(e) Average compression strength, ASTM D695	32,000 psi (220 MPa) min.
(f) Average compression modulus, ASTM D695	1,400,000 psi (9.7 GPa) min.
(g) Punch shear, ASTM D732	13,000 psi (90 MPa) min.
(h) Thickness	0.13±0.004 in (3.4±0.1 mm)
(i) Size, dimension less than 12 ft (3.6 m), ASTM D3841	±0.12 in (±3 mm)
(j) Squareness in 12-ft (3.6-m) length, ASTM D3841	±0.12 in (±3 mm)
(k) Surfaces, top and bottom	Smooth
(l) Color, visually uniform gray, Munsell color system	N7.5 to N8.5
(m) Coefficient of lineal thermal expansion, ASTM D696	0.000004 in/in/°F (0.1 µm/mm/°C) max.
(n) Flame resistance (extent of burning), ASTM D635	1 in (25 mm) max.
(o) Weather resistance, ASTM D3841	Grade 1 or 2

(e) **Extruded aluminum.** Furnish panels conforming to ASTM B221, aluminum alloy 6063-T6. Conform to Subsection 718.03(c) for panel thickness and fabrication. The maximum allowable deviation from flat on the face is 0.05 inches per foot (4 millimeters per meter).

**718.04 Sign Posts.** Furnish sign posts that are straight, smooth, and without defects affecting strength, durability, or appearance. Conform to the following:

(a) **Wood.** Furnish posts conforming to AASHTO M 168. Treat the posts according to Category 4A of the AWWA Standard U1-UC4A, *Ground Contact, General Use* for waterborne preservative treatments ACA, ACZA, or CCA.

(b) **Galvanized metal.** Conform to the following:

(1) **U-channel steel.** Furnish flanged, channel, galvanized steel posts conforming to ASTM A499, Grade 60 (420) and the following:

(a) *Punching.* Starting 1 inch (25 millimeters) from the top and extending the full length of the post, drill or punch  $\frac{3}{8}$ -inch (10-millimeter) holes on 1-inch (25 millimeter) centers along the centerline of the bottom of the U. Remove burrs and sharp edges.

(b) Galvanizing after punching AASHTO M 111

**(2) Square tubular steel.** Furnish square tubular galvanized steel posts conforming to ASTM A1011, Grade 55 (380) and the following:

(a) *Punching.* Starting 1 inch (25 millimeters) from the top and extending the full length of the post, drill or punch  $\frac{7}{16}$ -inch (11-millimeter) holes on 1-inch (25-millimeter) centers along the centerline of all four sides, in true alignment and opposite each other directly and diagonally. Remove burrs and sharp edges.

(b) Galvanizing after punching ASTM A123 or ASTM B695

(c) **Aluminum.** Furnish standard shapes and thicknesses conforming to ASTM B221, alloy 6061-T6, 6351-T5, 6063-T6, or 6005-T5.

(d) **Corrosion resistant steel.** Furnish posts conforming to ASTM A588 or ASTM A242. Zinc-coat the embedded portion of the corrosion resistant steel post according to ASTM A123.

**718.05 Object Marker and Delineator Posts.** Conform to the following:

(a) **Wood.** Furnish 4- by 4-inch (100- by 100-millimeter) wooden posts conforming to Subsection 718.04(a).

(b) **Steel.** Furnish flanged U-channel steel posts weighing not less than 2 pounds per foot (3 kilograms per meter) and conforming to ASTM A36. Galvanize according to AASHTO M 111.

(c) **Aluminum.** Furnish standard shaped  $\frac{1}{8}$ -inch (3-millimeter) thick aluminum posts conforming to ASTM B221, alloy 6063-T6.

(d) **Plastic.** Furnish flexible delineator posts made with high-impact resistant polymer material.

**718.06 Hardware.** Furnish galvanized steel or aluminum alloy lag screws, washers, clip angles, wood screws, shear plates, U-bolts, clamps, bolts, nuts, and other fasteners.

For high-strength steel bolts, nuts, and washers, conform to Subsection 717.01(e). Galvanize steel hardware according to AASHTO M 232.

For aluminum alloy bolts, nuts, and washers, conform to Subsections 717.12 and 717.13 as applicable.

For neoprene or nylon washers, furnish  $\frac{1}{8}$  inch (3.2 millimeters) thick by 1-inch (25 millimeters) minimum outside diameter with maximum allowable applied torque 480 inch-pounds (54 Newton-meters).

**718.07 Legends and Borders.** Use colors specified in plans or the MUTCD, *Standard Highway Signs, Including Pavement Marking Standard Alphabets* and material conforming to Subsection 718.01.

**718.08 Delineator and Object Marker Retroreflectors.** Furnish retroreflectors that are ready for mounting.

**(a) Type 1 (acrylic plastic lens).** Furnish an acrylic plastic lens with a minimum dimension of 3 inches (75 millimeters) with prismatic optical elements and a smooth, clear, transparent face. Fabricate the back from similar material and fuse it to the lens around the entire perimeter to form a homogenous unit. Seal the units against the intrusion of foreign material. Conform to Table 718-1 regardless of the orientation angle.

**Table 718-1**  
**Minimum Coefficient of (Retroreflective)**  
**Luminous Intensity ( $R_I$ )<sup>(1)</sup>**

Candelas per Foot-candle				
Observation Angle	Entrance Angle	White <sup>(2)</sup>	Yellow	Red
0.1°	0°	115	70	30
0.1°	20°	45	25	12
Candelas per Lux				
Observation Angle	Entrance Angle	White <sup>(2)</sup>	Yellow	Red
0.1°	0°	10.7	6.5	2.8
0.1°	20°	4.2	2.3	1.1

(1) See AASHTO T 257.

(2) Crystal, clear, or colorless are acceptable color designations.

Mount the retroreflector unit in a housing fabricated from 0.063-inch (1.6-millimeter) ASTM B209, aluminum alloy 3003-H-14 or similar, or from 0.064-inch (1.6-millimeter) cold rolled and hot dip galvanized steel. Furnish antitheft attachment hardware.

**(b) Type 2 (retroreflective sheeting).** Furnish a prismatic retroreflective sheeting with a minimum dimension of 3 inches (75 millimeters) and with a Class 1 or Class 2 adhesive backing conforming to Subsection 718.01. Attach the sheeting to an aluminum or plastic support panel (target plate) of the size and dimension specified.

**718.09 Solventborne Traffic Paint.** Conform to AASHTO M 248, Type N or Type F traffic paint.

Use volatile organic content (VOC) compliant solventborne paint with a VOC of 0.134 ounces per gallon (150 grams per liter) or less. Yellow pigment must be without lead, chrome, and other heavy metals as defined by the EPA.

**718.10 Waterborne Traffic Paint.** Furnish an acrylic water-based, ready-mixed paint conforming to the following:

**(a) Composition.** Furnish a paint composed of resin solids of 100 percent acrylic polymer with the exact formulation determined by the manufacturer. Conform to the following:

(1) Pigment, ASTM D3723

45 to 55 percent by mass



(2) Lead, chromium, cadmium, or cobalt ASTM D3335 & ASTM D3718	0 percent by mass
(3) Volatile organic compounds, EPA Method 24	20.0 oz/gallon (150 g/L) max.
(4) Density of paint, ASTM D1475	12.0 lb/gallon (1.44 kg/L) min.
<b>(b) Viscosity.</b> ASTM D562	75-90 Krebs units
<b>(c) Drying time.</b>	
(1) Dry to no pickup, ASTM D711	10 minutes max.
(2) Drying to no track, ASTM D713	90 seconds max.
<b>(d) Flexibility.</b> ASTM D522, using the ¼-in (6.4-mm) cylindrical mandrel	No cracking or flaking
<b>(e) Dry opacity.</b> ASTM D2805, contrast ratio at 319 ft <sup>2</sup> /gallon (7.85 m <sup>2</sup> /L) spreading rate	0.96 min.
<b>(f) Color.</b>	
(1) White, ASTM D1729	Match FHWA standard highway white
(2) Yellow, ASTM D1729	Match FHWA standard highway yellow
<b>(g) Daylight reflectance.</b> (Without glass beads)	
(1) White, ASTM E1347	84 percent relative to magnesium oxide standard
(2) Yellow, ASTM E1347	55 percent relative to magnesium oxide standard
<b>(h) Bleeding ratio.</b> ASTM D868. Determine reflectance according to ASTM D1347 immediately after drying. Divide the average of three reflectance readings of the paint over the bleeding surface by the average of three readings over the non-bleeding surface to determine the bleeding ratio	0.96 min.
<b>(i) Freeze-thaw stability.</b> ASTM D2243	±5 Krebs units max.
<b>(j) Storage stability.</b> During a 12-month storage period, conform to the following:	
(1) No excessive setting, caking, or increase in viscosity; and	
(2) Readily stirred to a consistency for use in the striping equipment.	

**718.11 Epoxy Markings.** Furnish a 2-component, 100 percent solids type system for hot-spray application conforming to the following:

(a) **Pigments.** Component A. Percent by mass.

(1) **White.**

(a) Titanium dioxide (TiO<sub>2</sub>),  
ASTM D476, Type IV 18 percent min.

(b) Epoxy resin, ASTM D1652 75 to 82 percent

(2) **Yellow:**

(a) Chrome yellow (PbCrO<sub>4</sub>),  
ASTM D126 23 percent min.

(b) Epoxy resin, ASTM D1652 70 to 77 percent

(3) **Non-Lead Yellow:**

(a) Titanium dioxide (TiO<sub>2</sub>)  
ASTM D476, Type II and Type III 14 percent min.

(b) Organic yellow 7 to 8 percent

(c) Epoxy resin, ASTM D1652 75 to 79 percent

(b) **Epoxy content.** Component A.  
Mass per epoxy equivalent,  
ASTM D1652

Manufacturer's target  
value  $\pm 50$

(c) **Amine value.** Component B,  
ASTM D2074

Manufacturer's target  
value  $\pm 50$

(d) **Toxicity.** Toxic or injurious fumes  
at application temperature

None

(e) **Color.** 15 mil (0.38 millimeter) film thickness specimen (cured).

(1) White, ASTM D1729 Match FHWA standard  
highway white

(2) Yellow, ASTM D1729 Match FHWA standard  
highway yellow

(f) **Directional reflectance.** (Without glass beads)

(1) White, ASTM E1347 84 percent relative to  
magnesium oxide standard

(2) Yellow, ASTM E1347 55 percent relative to  
magnesium oxide standard

**(g) Drying time.** 15-mil (0.38-millimeter) film thickness with glass beads (cured).

**(1) Laboratory at 72 °F (22 °C),** 30 minutes max.  
ASTM D711 to no-pick-up condition

**(2) Field at 77 °F (25 °C), viewed from** 10 minutes max.  
50 ft (15 m), ASTM D713 to no-tracking condition

**(h) Abrasion resistance.** Wear index 82 max.  
with a CS-17 wheel under a 35.3 oz (1000 g) load  
for 1000 cycles, ASTM D4060

**(i) Hardness.** Type D hardness with 75 to 100  
72-hour cure at 72 °F (22 °C), ASTM D2240

**718.12 Thermoplastic Markings.** Conform to AASHTO M 249.

**718.13 Preformed Pavement Marking Tape.** Conform to ASTM D4505, Reflectivity Level I; Class 1, 2, or 3; Skid Resistance Level A or B.

**718.14 Glass Beads.** Conform to AASHTO M 247 for the type specified. Treat glass beads with an adherence coating as recommended by manufacturer.

**718.15 Pavement Markers.**

**(a) Non-plowable, extended life, retroreflective, pavement markers.** Conform to ASTM D4280.

**(b) Plowable, retroreflective, pavement markers.** Conform to ASTM D4383.

**(c) Non-reflective pavement markers.** Furnish ceramic, plastic, or thermoplastic markers that are  $4\pm\frac{1}{8}$  inch (100±3 millimeters) in diameter at the base,  $\frac{11}{16}\pm\frac{1}{16}$  inch (17.5±1.6 millimeters) in height, and where the base of the marker does not deviate from a flat plane by more than  $\frac{1}{16}$  inch (1.6 millimeters).

Furnish markers of uniform composition, without surface irregularities, cracks, checks, chipping, peeling, spalling, crazing, and other physical damage interfering with appearance, application, or durability. Furnish precast markers in the form of a single based spheroidal segment terminating in a rounded or squared shoulder.

**718.16 Temporary Pavement Markings.**

**(a) Preformed retroreflective tape.** Furnish 4-inch (100-millimeter) wide tape conforming to ASTM D4592, Type I (removable).

**(b) Pavement markers.** Furnish temporary pavement markers conforming to ASTM D4280 or flexible pavement markers not exceeding approximately 2 inches (50 millimeters) high, with retroreflective tape on both faces of the vertical section, capable of retroreflecting light from opposite directions, and with an adhesive on the base.

**(c) Traffic paint.** Conform to Subsections 718.09 or 718.10.

**718.17 Epoxy Resin Adhesives.** Furnish epoxy resin adhesives conforming to AASHTO M 237 for bonding traffic markers to rigid and asphalt concrete pavements.

## Section 725. — MISCELLANEOUS MATERIAL

### 725.01 Water. Conform to the following:

(a) **Water for mixing or curing cement concrete, mortar, or grout.** Conform to AASHTO M 157. Potable water of known quality may be used without testing according to AASHTO T 26. Potable water is safe for human consumption as defined by the public health authority having jurisdiction.

(b) **Water for planting or care of vegetation.** Furnish water that is free of substances injurious to plant life (such as oils, acids, alkalies, or salts).

(c) **Water for earthwork, pavement courses, dust control, and incidental construction.** Furnish water free of substances detrimental to the work.

### 725.02 Calcium Chloride, Magnesium Chloride, and Lignosulfonate.

(a) **Calcium chloride liquid.** Furnish a water solution conforming to the following:

- |                              |                      |
|------------------------------|----------------------|
| (1) Calcium chloride liquid  | AASHTO M 144, Type L |
| (2) Calcium chloride by mass | 35 percent min.      |

(b) **Calcium chloride flake.** Conform to AASHTO M 144, Type S, Grades 1, 2, or 3, Class A.

(c) **Magnesium chloride liquid.** Furnish a water solution conforming to the following:

- |                                  |                 |
|----------------------------------|-----------------|
| (1) Magnesium chloride by mass   | 28 percent min. |
| (2) Specific gravity, ASTM D1298 | 1.29 to 1.33    |

(d) **Lignosulfonate liquid.** Furnish a water solution with a base cation of ammonia, calcium, or sodium. Conform to the following:

- |                                  |            |
|----------------------------------|------------|
| (1) Dry solids <sup>(1)</sup>    | 50 percent |
| (2) Specific gravity, ASTM D1475 | 1.20 min.  |
| (3) pH, ASTM E70                 | 3.0 to 8.0 |

Note (1) Use Pulp and Paper Technical Association of Canada standard test Method H.1, *Determination of Solids Content of Pulp and Paper Mill Effluents*.

### 725.03 Lime.

(a) **Lime for masonry.** Conform to ASTM C207, Type NA.

(b) **Lime for soil stabilization.** Conform to AASHTO M 216.

(c) **Lime for asphalt mixtures.** Conform to AASHTO M 303.

**725.04 Pozzolans.**

- |  |                  |
|--|------------------|
| <p><b>(a) Fly ash.</b> Conform to AASHTO M 295, Class C or Class F.<br/>When used to mitigate alkali-silica reactivity, also available alkalies as equivalent Na<sub>2</sub>O</p>                              | 1.5 percent max. |
| <p><b>(b) Ground granulated blast-furnace slag.</b><br/>Conform to AASHTO M 302, Grade 100 or Grade 120. When used to mitigate alkali-silica reactivity, also total alkalies as equivalent Na<sub>2</sub>O</p> | 1.0 percent max. |
| <p><b>(c) Silica fume (microsilica).</b><br/>Conform to AASHTO M 307.<br/>When used to mitigate alkali-silica reactivity, also total alkalies as equivalent Na<sub>2</sub>O</p>                                | 1.0 percent max. |

**725.05 Mineral Filler.** Conform to AASHTO M 17.

**725.06 Concrete Building Brick.** Conform to ASTM C55, normal weight.

**725.07 Concrete Masonry Units.** Conform to one of the following:

- |   |                          |
|---|--------------------------|
| <p><b>(a)</b> Loadbearing concrete masonry units</p>                                | ASTM C90, normal weight  |
| <p><b>(b)</b> Concrete masonry units for constructing catch basins and manholes</p> | ASTM C139                |
| <p><b>(c)</b> Nonloadbearing concrete masonry units</p>                             | ASTM C129, normal weight |

**725.08 Paving Brick.** Conform to one of the following:

- |   |                                    |
|---|------------------------------------|
| <p><b>(a)</b> Pedestrian and light traffic paving brick</p> | ASTM C902, Class SX, Type I        |
| <p><b>(b)</b> Heavy vehicular paving brick</p>              | ASTM C1272, Type F, Application PS |

**725.09 Precast Concrete Units and Accessories.** Conform to the following:

- |  |              |
|--|--------------|
| <p><b>(a)</b> Precast reinforced concrete manhole sections</p>     | AASHTO M 199 |
| <p><b>(b)</b> Precast concrete barrier</p>                         | ASTM C825    |
| <p><b>(c)</b> Concrete grid paving units</p>                       | ASTM C1319   |
| <p><b>(d)</b> Underground precast concrete utility structures</p>  | ASTM C858    |
| <p><b>(e)</b> Precast concrete water and wastewater structures</p> | ASTM C913    |
| <p><b>(f)</b> Solid concrete interlocking paving units</p>         | ASTM C936    |

**(g) Other precast concrete units and accessories****Section 601**

**725.10 Frames, Grates, Covers, and Ladder Rungs.** Fabricate metal grates and covers to evenly bear on the frames. Correct bearing inaccuracies by machining. Assemble units before shipment. Mark pieces to facilitate reassembly at the installation site. Uniformly coat castings with a commercial preservative according to the manufacturer's standard practice. Conform to the following:

- |  |                          |
|--|--------------------------|
| <b>(a)</b> Gray iron castings                  | AASHTO M 105             |
| <b>(b)</b> Carbon steel castings               | AASHTO M 103             |
| <b>(c)</b> Structural steel                    | ASTM A36                 |
| <b>(d)</b> Galvanizing                         | AASHTO M 111             |
| <b>(e)</b> Malleable iron castings             | ASTM A47                 |
| <b>(f)</b> Aluminum alloy ladder rung material | ASTM B221, alloy 6061-T6 |
| <b>(g)</b> Aluminum castings                   | ASTM B26, alloy 356.0-T6 |

**725.11 Corrugated Metal Units.** Conform to AASHTO M 36 for steel corrugated units. Conform to AASHTO M 196 for aluminum corrugated units. For coatings, conform to the following:

- |   |                                |
|---|--------------------------------|
| <b>(a)</b> Bituminous-coated corrugated units | AASHTO M 190, Type A           |
| <b>(b)</b> Polymer-precoated corrugated units | AASHTO M 245,<br>Grade 250/250 |

**725.12 Plastic Lining.** Furnish a film or fabric that is serviceable for the duration of the installation.

**725.13 Grout.****(a) Neat hydraulic cement grout.**

**(1) Ground anchors, micropiles, and soil nails.** Furnish a pumpable mixture of portland cement, sand, water, and admixtures. Use Type II portland cement conforming to AASHTO M 85. Furnish sand according to Subsection 703.01. Furnish water according to Subsection 725.01(a). Provide the minimum water content necessary for placement and a maximum water/cementitious material ratio of 0.45 by mass.

Chemical admixtures that control bleed or retard set may be used provided the additives conform to Subsection 711.03 and are mixed according to the manufacturer's recommendations. Do not use admixtures containing more than trace (from impurities, not as an intended constituent) quantities of chlorides, fluorides, aluminum, zinc, or nitrates.

The maximum water-soluble chloride ion (Cl<sup>-</sup>) content of the grout is 0.06 percent Cl<sup>-</sup> by mass of cement when tested according to ASTM C1218.

Furnish grout conforming to the following minimum compressive strengths:

(a) Ground anchors	3,500 lb/in <sup>2</sup> (25 MPa) at 7 days
(b) Micropiles	2,500 lb/in <sup>2</sup> (17.5 MPa) at 7 days and 5,000 lb/in <sup>2</sup> (35 MPa) at 28 days
(c) Soil nails	1,500 lb/in <sup>2</sup> (10.5 MPa) in 3 days and 3,000 lb/in <sup>2</sup> (21 MPa) in 28 days

**(2) Miscellaneous applications.** Furnish a grout consisting of a mixture of hydraulic cement, water, and admixtures. Do not exceed a water/cementitious material ratio of 0.44. Do not exceed 20 percent of the cement by mass if fly ash is used. Admixtures to reduce water content, improve the flowability, control bleeding, or control shrinkage may be added according to the manufacturer's recommendations. Furnish admixtures free of chlorides, fluorides, sulphites, and nitrates.

**(b) Nonshrink grout.** Conform to ASTM C1107. Provide a minimum compressive strength of 5,000 pounds per square inch (35 megapascals) in 3 days.

**(c) Grout for post-tensioned structures.** Conform to the requirements of the PTI, *Guide Specification for Grouting of Post-Tensioned Structures*.

**(d) Polyester resin grout.** Furnish polyester resin grout with a minimum ultimate compressive strength of 14,000 pounds per square inch (97 megapascals), a minimum ultimate tensile strength of 2,500 pounds per square inch (17 megapascals), and a minimum ultimate shear strength of 4,500 pounds per square inch (31 megapascals) when fully cured. Conform to ASTM F432, except where noted.

Furnish polyester resin grout consisting of an unsaturated polyester resin, evenly filled with nonreactive, inorganic aggregate of suitable size, and a separated catalyst filled with nonreactive inorganic filler. Supply resin in cartridge form. Provide cartridge lengths and diameters according to the manufacturer recommendations for the specified drill hole and reinforcing bar size. Provide resin cartridges readily and individually identified as to their respective gel times.

**725.14 Polymer Concrete and Mortar.** Furnish a polymer binder and fine aggregate in the proportions recommended by the polymer manufacturer with a minimum compressive strength of 3,500 pounds per square inch (25 megapascals) in 4 hours. Conform to the following:

**(a) Epoxy mortar.** Conform to ACI 503.4.

**(b) Other polymer concrete or mortar.** Conform to ASTM C1438, Type II.

**725.15 Color Coating.** Furnish a semi-opaque colored toner containing methyl methacrylate-ethyl acrylate copolymer resins or equivalent resins, solvents, and color-toning pigments suspended in solution by a chemical suspension agent. Provide color-toning pigments consisting of laminar silicates, titanium dioxide, and inorganic oxides. Conform to the following:

**(a) Mass per liter, ASTM D1475** 8.3 lb (38 kg) min.

**(b) Solids by mass, ASTM D2369** 30 percent min.



(c) Solids by volume	21 percent min.
(d) Drying time, ASTM D1640	30 minutes at 70 °F (21 °C) and 50 percent max. humidity
(e) Color change, ASTM D822, 1000 hours	No appreciable change
(f) Resistance to acids, alkalies, gasoline, and mineral spirits, ASTM D543	Excellent
(g) Water vapor transmission from interior concrete, ASTM D1653	Transmittable
(h) Oxidation over time	None

**725.16 Slurry (Drilling Fluids).**

(a) **Mineral slurry.** Furnish sodium bentonite or attapulgite in potable water. Use a mineral grain size that remains in suspension with sufficient viscosity and gel characteristics to transport drilled material out of the hole.

(b) **Polymer slurry.** Furnish a slurry compatible with soil type and water chemistry.

**725.17 Reinforcing Fibers.**

(a) **Fibers for shotcrete.** Use deformed steel or fibrillated polyolefin fibers conforming to ASTM A820 or ASTM D7508.

(b) **Fibers for concrete.** Use fully oriented, collated, fibrillated, white, 3/4-inch (19-millimeter) long fibers of 100 percent virgin polyolefin conforming to ASTM D7508. Dose at 1.5 to 3 pounds per cubic yard (0.9 to 1.8 kilograms per cubic meter) of concrete.

**725.18 Epoxy Resin Adhesives.** Furnish epoxy resin adhesives conforming to AASHTO M 235 for structural concrete injection and crack repair.