

## Request for Proposal



Bid Number: 26-05-4139SB

The Navajo Nation Office of the Controller - Purchasing Department and the Navajo Division of Transportation (Navajo DOT) are soliciting proposals and sealed bids for “[Bid #, 26-05-4139SB N9659 Coyote Canyon Gravel Project.](#)”

Bid Documents are available on the Navajo DOT’s website: [www.navajodot.org](http://www.navajodot.org)

Contacts for a bid packet are:

- 1) Joe Peterman, Department Manager, Navajo Division of Transportation – Roads, [jpeterman@navajodot.org](mailto:jpeterman@navajodot.org); (928) 797-0150 or (505) 371-8392.
- 2) Sharon Belone, Navajo Nation Purchasing Department, [sharon.belone@navajo-nsn.gov](mailto:sharon.belone@navajo-nsn.gov) (928) 871-6142.

Closing date is [May 29, 2026](#), at 3:00 p.m.MDT. Any proposal(s) received after this date and time will not be accepted and will be returned to the sender. No faxed or email proposals or bids will be accepted.

## PROPOSAL SUBMITTAL

All proposals MUST have the Prospective Respondent's name and contact information on the outside of the Sealed Proposal Packet and Proposal Cost (envelopes). If not included, it will be considered "non-Responsive."

All proposals are to be submitted to:

Mailing Address:

Navajo Division of Transportation – Roads  
Attention: Joe Peterman, Department Manager  
P.O. Box 4620  
Window Rock, AZ 86515  
Phone: (505) 371-8300

Hand Delivery: Driving Instructions from Gallup, New Mexico

Take Exit 20 from I-40. Take US491 north from Gallup, New Mexico to Yatahey, NM, which is approximately 5.5 miles. Approach a Y-Intersection. Take US264 and go about 15 miles. The Navajo Division of Transportation Complex will be on the right side of US491 on Indian Route 5.

All proposals and bid forms shall be sent in sealed envelope, clearly marked with the following information:

RFP Bid Number: 26-05-4139SB

Description or Title: N9659 Coyote Canyon Wells Gravel Project

Contact Persons: Sharon Belone  
Navajo Nation Purchasing Department  
Phone: (928) 871-6142  
Email: [sharon.belone@navajo-nsn.gov](mailto:sharon.belone@navajo-nsn.gov)

Joe Peterman, Department Manager  
Navajo Division of Transportation - Department of Roads  
Phone: (505) 371-8392  
Cell: (928) 797-0150  
Email: [jpeterman@navajodot.org](mailto:jpeterman@navajodot.org)

Please submit an Original and three (3) copies of proposals.

## PART I

### **INFORMATION ONLY – NO RESPONSE TO THIS SECTION IS REQUIRED**

- A. This Request for Proposal (RFP) provides the prospective respondents with sufficient information that will enable them to prepare and submit a proposal for consideration.
- B. This RFP contains the instructions governing the proposals to be submitted and the materials to be included. These are mandatory requirements which must be met to be eligible for consideration. Failure to adhere will result in a “Non-Responsive” Status.
- C. SCHEDULE OF ACTIVITIES AND TIMELINES:

Schedule of Activities	Timelines
Proposal Site visit and meeting	May 21, 2026, at 11:00 am. MDT  The meeting shall be at the Twin Lakes Chapter house, 1472 US491. A site visit will ensue.
Prospective respondents “Inquiry Timeline.” All inquiries and questions will be answered prior to this date. Questions must be submitted in writing only. If needed, an Addendum will be issued to all vendors who requested for a copy of the RFP to ensure they all received the same information. No questions accepted after this date.	May 26, 2026, at 5:00 p.m.
Due date for all proposals	Friday, May 29, 2026, at 3:00 p.m.
Bid Opening of proposals and evaluations by the Review Panel	Week of June 01, 2026
Award of Contract – It takes at least six to eight weeks to process a contract.	By September, 2026

- D. INQUIRIES: Prospective respondents may contact Navajo Division of Transportation (DOT) – Department of Roads staff via phone call or email about this RFP in obtaining clarification of requirements. No inquiries will be accepted after the inquiring date listed in Section C.
- E. ADDENDUM OR SUPPLEMENT TO THIS REQUEST FOR PROPOSALS: In the event it becomes necessary to revise any part of this RFP, an addendum will be issued. Any respondents that already submitted a proposal will be notified.
- F. PROPOSALS SUBMISSION: Proposal must be received on [Friday May 29 2026, by 3:00 p.m. MDT](#). Respondents who are mailing their proposals should allow sufficient time for mail delivery to ensure receipt by the time specified. If mailed, it is recommended that proposals be sent by certified mail to the address indicated on the [Page 2](#) of this RFP.
- G. NUMBER OF PROPOSALS TO BE SUBMITTED: In the submission of all proposals, one original and three (3) copies must be enclosed in one sealed envelope. The outside of the envelope should be clearly marked with 1) Respondent’s Contact information, and 2) the “[Bid Number #26-05-4139SB, N9659 Coyote Canyon Gravel Project](#)”

- H. **LATE RECEIPT OF PROPOSALS:** Late proposal will not be accepted. It is the responsibility of the respondent to ensure that the proposal arrives at the Navajo Division of Transportation – Department of Roads on or before the date/time specified.
- I. **REJECTION OF PROPOSALS:** The Navajo Division of Transportation (Navajo DOT) – Department of Roads reserves the right to reject any or all proposals and to waive informalities and minor irregularities in the proposals received.
- J. **PROPRIETARY INFORMATION:** Any restriction on the use of the information, data, contents contained within the proposals must be clearly stated in the proposal itself. Each page of the propriety material must be labeled or identified with the word “Proprietary.” Proprietary information submitted in response to this RFP will be handled in accordance with applicable procurement regulations.
- K. **PROPOSAL MATERIAL OWNERSHIP:** All material submitted in reference to this RFP shall become the property of the Navajo Nation and will not be returned to the respondent. Responses received will be retained by the Navajo DOT – Department of Roads and may be reviewed by any person(s) after the final selection has been made, subject to [Section J](#). The Navajo DOT – Department of Roads has the right to use any or all systems, ideas presented in this RFP, subject to limitations in [Section J](#). Disqualification or non-selection of a respondent does not eliminate this right.
- L. **INCURRING COSTS:** The Navajo DOT – Department of Roads is not liable for any cost incurred by the Respondent prior to issuance of service contract or a purchase order.
- M. **ACCEPTANCE OF PROPOSAL CONTENT:** The contents of the proposal of the successful Respondent will become contractual obligation if acquisition action ensues. Failure of the successful Respondents to accept this obligation may result in cancellation of the award and such respondent may be removed from consideration for future solicitation.
- N. **ACCEPTANCE TIME:** The Navajo DOT – Department of Roads, in coordination with the Navajo Nation Business Regulatory Department and the Navajo Nation Office of the Controller, intends to select the successful Respondent in the time specified in [Section C](#), after the closing date of receipt of proposals.
- O. **AWARD OF SERVICE CONTRACT:** Upon selection, Navajo DOT – Department of Roads will initiate the Service Contract and License Agreement in the name of the successful respondent; and the contents of the proposal submitted by the respondent will become part of the contract.
- P. **JOINT PROPOSALS:** Nothing in this RFP shall be construed to prohibit respondents from entering a consortium for the purpose of offering a proposal in response to this RFP. Parties to a consortium will not be permitted to submit independent proposals in response to this RFP.

Q. EVALUATION PROCEDURE AND CRITERIA:

- a. Review Panel: A Review Panel, with specific related technical background, will be selected and evaluate the proposals received in accordance with general criteria used herein. The review panel may request for a meeting for purposes of proposal clarification and the respondent should be prepared to provide any additional information the Review Panel feels necessary for a fair evaluation of the proposals.
- b. Failure of a respondent to provide any information requested in this RFP may result in the proposal being disqualified. All proposals must be endorsed with the signature of a responsible official having the authority to bind the respondent in the execution of a contract.
- c. The sole objective of the review panel is to select the respondent most responsive to the needs of the Navajo Nation, Navajo DOT, and the Department of Roads. The specification in this RFP represents the minimum performance necessary for a response. Based on the evaluation criteria established in this RFP, the Review Panel will select and recommend the respondent who best meets the objective in the Scope of Work in Part II.
- d. The Technical Proposal Factors will be used to evaluate the proposal(s) based on a 100 points-scale system, with 10 additional points for Navajo Nation Priority #1 Businesses, and five (5) additional points for Navajo Nation Priority #2 Businesses.

**Evaluation Sheet**

<b>Proposal Factors</b>	<b>Requirements</b>	<b>Maximum Points Awarded</b>
Proposal Format	10 single sided pages and spiral-bind proposal	5
Scope of Work	Describe the company's capabilities to perform grade, drain, gravel of existing earth road, and traffic control.	75 points
Certificate and Insurance requirements	Certificate of Insurance.	5
Communication	How will company communicate with Navajo DOT regarding project operations	5
Two References	List two references of companies that your company has performed this type of service for.	10
	<b>TOTAL</b>	100
<b>Certified Navajo Nation Business Owner – 100%</b>	<b>PRIORITY #1</b>	<b>10</b>
<b>Certified Navajo Nation Business Owner – 51%</b>	<b>PRIORITY #2</b>	<b>5</b>
<b>TOTAL</b>	<b>Total for Priority #1</b>	<b>110</b>
	<b>Total for Priority #2</b>	<b>105</b>
	<b>Total for Non-Priority</b>	<b>100</b>

- R. Per the NAVAJO NATION PROCUREMENT CODE, 12 N.N.C., Section 332, Letter “e”, in the event all proposal in a Procurement exceeds available funds by 5%, a re-solicitation for work or a reduced scope may be authorized.
- S. STANDARD CONTRACT: Navajo DOT will use the template Service Contract reviewed and approved by the Navajo Nation Department of Justice.
- T. RETURN PROPOSAL: The Navajo Nation and Navajo DOT have no obligation in returning any of the proposal received in response to this RFP.
- U. TERM: The term of the Service Contract will be a period of one year from the date of *Notice to Proceed*, with an option to extend the contract for continued services, which will be based upon the availability of funds. Renewal of the contract will be made only upon mutual agreement of both parties.
- V. COMPLIANCE WITH THE NAVAJO NATION BUSINESS OPPORTUNITY ACT: Proposal will be opened and evaluated in compliance with the Navajo Nation's Business Opportunity Act, 5 N.N.C., Chapter 2, and Subsection 201 – 215 and the Navajo Nation Procurement Rules and Regulations.

## PART II

### SCOPE OF WORK

#### N9659, Coyote Canyon Gravel Project

Vendor shall provide all manpower, equipment, materials and incidentals to complete a road graveling project located at Coyote Canyon, NM, Navajo Route 9659. The work consists of blading, shaping and compacting the existing road for two +/- miles and placing 3" depth Aggregate Base Course. Note that the existing route is in fair condition with adequate drainage.

Bid Items shall be Roadway Reconditioning, Subgrade Preparation, Aggregate Base Course and Traffic Control Plan.

**ROADWAY RECONDITIONING:** grade and shape existing road to a 24' width with 8' 4:1 front slope and 3:1 back slope. If necessary, repair any soft and unstable areas, shape to a uniform surface, recompact to 95% compaction.

**SUBGRADE PREPARATION:** The top 6" of the roadway shall be processed and compacted to 95% moisture and density, the profile grade shall be graded at 2% from centerline to shoulder.

**Aggregate Base Course (ABC):** place ABC (Type 1 inch FP-14 Table 703-4) in 3" lift, grade to a uniform even surface, compact to 95% compaction.

**Traffic Control:** Provide a Traffic Control Plan (TCP) for approval two weeks prior to beginning construction. All signs, devices, flaggers, and other items shall be provided and implemented per the TCP. Note that the roadway shall be kept open to traffic during non-working hours and weekends.

#### **FACTORS:**

Applicable standards and specifications of the "Standard Specifications for Construction of Roads and Bridges on Federal Highway Projects" (FP-14) shall apply to all manpower, equipment, and workmanship.

Contractor shall obtain water from an approved source; this shall be incidental to the work.

All work shall be scheduled with the NDOT Roads Department manager who will oversee all construction.

### Part III

#### FORMAT AND ORGANIZATION

**Requirements:** This section of the RFP specifies the format and organization of the proposal (not listed in priority or in any order).

- A. NUMBER OF COPIES: Submit an Original and three (3) copies of proposal.
- B. PROPOSAL FORMAT: Appearance of the proposal is important and professionalism in the proposal presentation should not be neglected. The proposal standards are as follows:
  - a. The proposal shall not exceed 10 single-sided pages (maximum 8 1/2" x 11"). Submissions exceeding the 10 single-sided page limit will be considered non-responsive and will be unrated. All pages include dividers, proposal, photos, charts, graphs, exhibits, letter of interest, etc. are counted toward the 10 pages.
  - b. Proposal's submittal should be plastic or metal spiral-bound only. **Please do not submit loose paper, these will be considered unresponsive and will be unrated. No folders required, just spiral-bound proposals.**
- C. LETTER OF INTEREST: Letter of Interest must be on a Company Letterhead and signed by the president, executive director, or owner of the company/organization.
- D. PROOF OF CERTIFICATE OF INSURANCE: Provide a copy of Certificate of Insurance, include Workman's Compensation, Subrogatory Waiver and Additional Insured.
- E. SCOPE OF WORK: Respondent's approach to the scope of work, includes the following:  
SEE ABOVE.
- F. COMMUNICATION: Describe communication methods with Navajo DOT.
- G. CERTIFIED NAVAJO BUSINESS: If claiming Navajo Business Owner, **provide proof that business is currently certified by the Navajo Nation - Business Regulatory Department and prioritized under Navajo Nation Council Resolution CAP-37-02 and under the Section 204 (A) (1) and (2) of the revised Navajo Nation Business Opportunity Act.**
- H. TAXES: All performance under this Contract within the territorial jurisdiction of the Navajo Nation is subject to the six percent (6%) Navajo Sales Tax (24 N.N.C. 601 et seq.).
- I. BID FORM / PROPOSAL COST: In a **separate sealed envelope**, clearly marked as "**BID FORM, 26-05-4139SB N9659 Covote Canyon Gravel Project.**" and with Respondent's information. The sealed envelope will not be opened by the Review Team until after the proposals have been reviewed and ranked. **If your bid is not in a separate sealed envelope, then your proposal will be considered non-responsive and ineligible for further evaluation.**

End of RFP.

## **Attachments**

- 1) Bid Form
- 2) Typical Section
- 3) Map
- 4) Addendum Acknowledgement
- 5) Sample to Provide References

**Bid Form**  
**N9659 Coyote Canyon Gravel Project**  
**26-05-4139SB**

CONTRACTOR \_\_\_\_\_ DATE \_\_\_\_\_

Item Description	Quantity	Unit	Unit Price	Total
<b>Mobilization</b>	<b>1.00</b>	<b>LS</b>		
<b>Roadway Reconditioning</b>	<b>30,000.00</b>	<b>SY</b>		
<b>Subgrade Stabilization</b>	<b>30,000.00</b>	<b>SY</b>		
<b>Aggregate Base Course</b>	<b>5,500.00</b>	<b>TON</b>		
<b>Traffic Control Plan</b>	<b>1.00</b>	<b>LS</b>		
<b>Bid Item Total Cost</b>				
<b>Navajo Nation Tax (6%)</b>				
<b>TOTAL ESTIMATED PROJECT COST</b>				

Any taxes other than Navajo Nation Tax shall be the responsibility of the selected vendor, no separate line item shall be used for taxes other than that charged by the Navajo Nation.

### Typical Section N9659 Coyote Canyon Gravel Project

#### TYPICAL ROAD SECTION 24'-FT ROADWAY 4:1 DRAINAGE DITCH

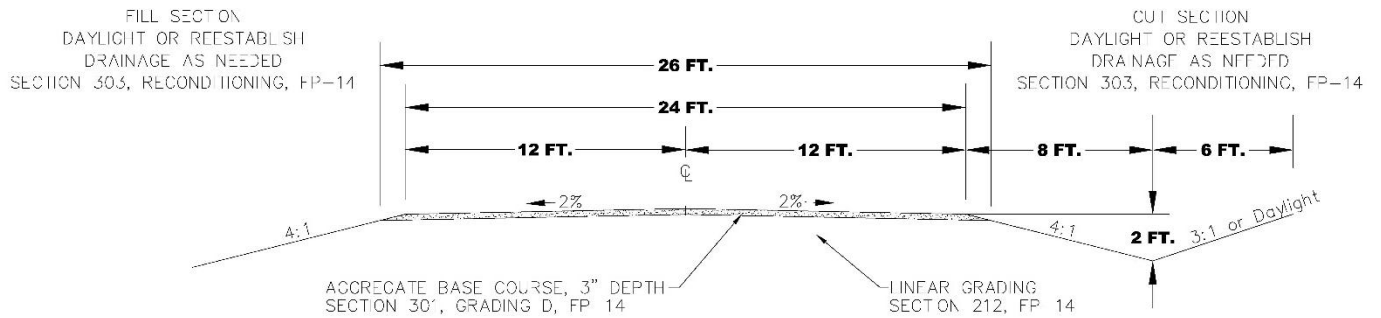



**ROUTE 9659 STRIP MAP  
SECTIONS 10 - 15  
FORT DEFIANCIE**

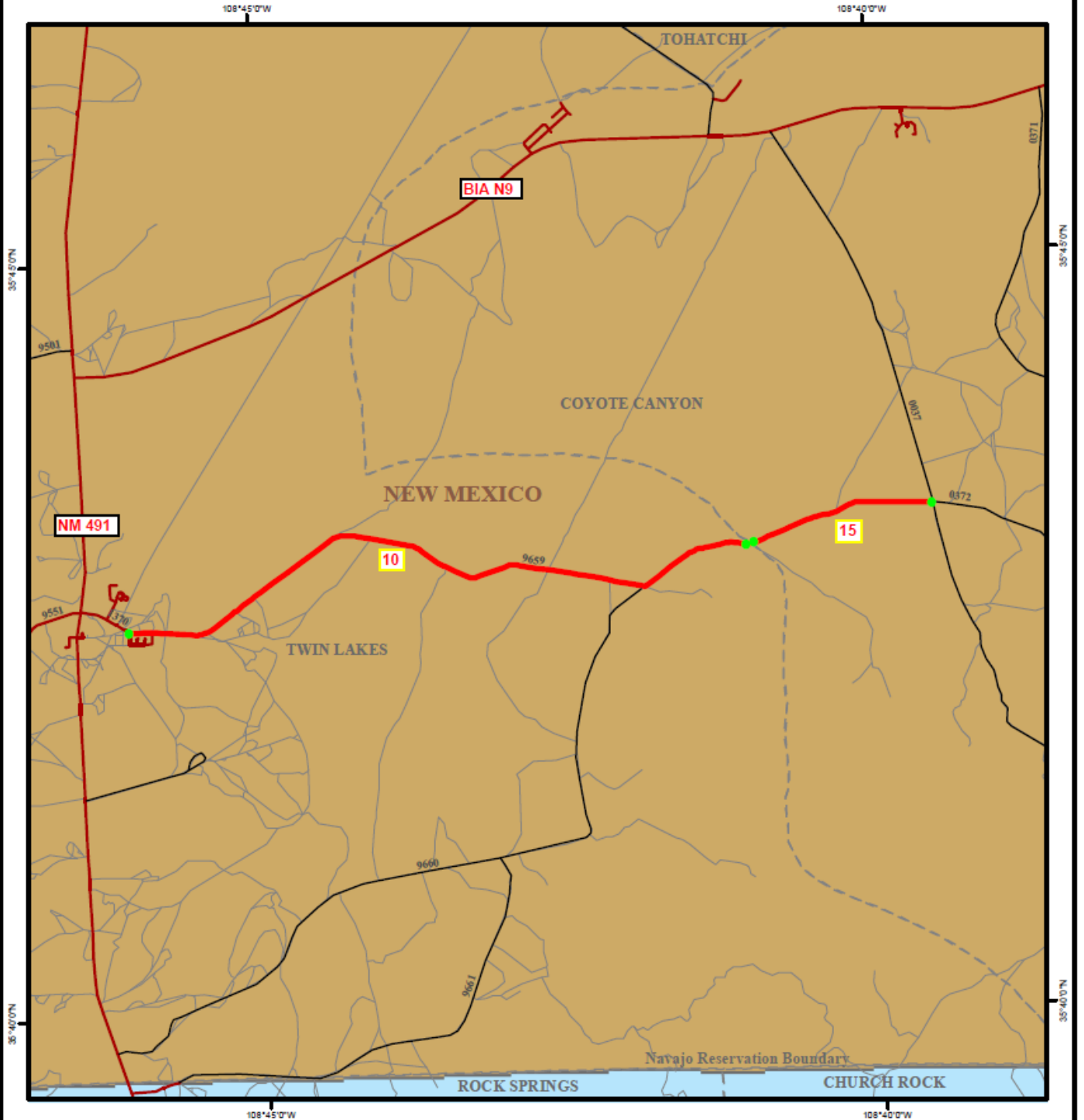

**Legend**

- |                        |                         |                    |                  |
|------------------------|-------------------------|--------------------|------------------|
| Selected Route         | Interstate Highway      | <b>Agency</b>      | NIP              |
| Limited Access Highway | State Highway           | 32 - Shiprock      | New Lands        |
| Paved Road             | County Road             | 33 - Western       | State Boundary   |
| BIA Road               | Bridges                 | 34 - Eastern       | County Boundary  |
| Other Road or Trail    | Latitude/Longitude Grid | 35 - Chinle        | Chapter Boundary |
|                        |                         | 36 - Fort Defiance |                  |

Length of Section Shown

7.1 miles

Ownership: BIA

Date: 5/31/2007

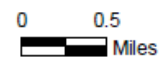

**Addendum Acknowledgement**

**Addendum:**

In submitting this Bid, Respondent represents that: *Respondent has examined and carefully studied the RFP and attachments, and any data and reference items identified in the RFP documents, and hereby acknowledges receipt of the following Addenda:*

**Addendum No:**

**Addendum Date:**

_____	_____
_____	_____
_____	_____

**Respondent will complete the Work in accordance with the Contract Documents for the following price(s):**

Respondent's Acknowledgement Signature:

\_\_\_\_\_

Name and Title

Company Name

**SAMPLE TO PROVIDE REFERENCES****Reference One:**

John Doe, Owner  
Company Name: Navajo Nation  
P.O. Box 123  
Window Rock, AZ 86515  
Phone: (928) 871-1000  
Email: [jdoe@yahoo.com](mailto:jdoe@yahoo.com)  
Scope of work: Paved Route N12

**Reference Two:**

Jane Doe, Owner  
Company Name: Arviso Construction  
P.O. Box 456  
Tuba City, AZ 86515  
Phone: (928) 283-1000  
Email: [janed@yahoo.com](mailto:janed@yahoo.com)  
Scope of work: Paved main road to school.

---

*Navajo DOT may contact the references for  
performance appraisal.*

---