

# GENERAL WATER SYSTEMS

THIS DRAWING IS FOR SPATIAL CONSIDERATION ONLY, AND SUBJECT TO CHANGE W/O PREVIOUS NOTICE, DO NOT PRE-PLUMB TO THESE DIMENSIONS

## SEPARATOR

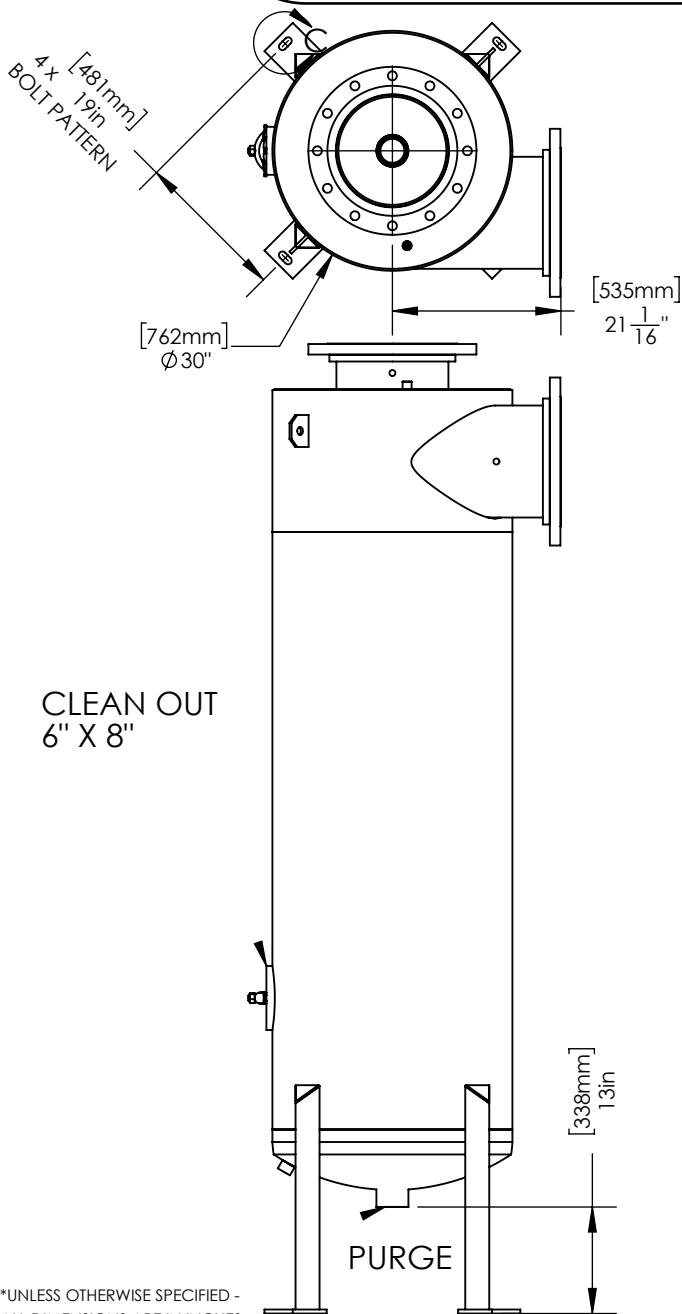

### DETAIL C SCALE 1 : 12

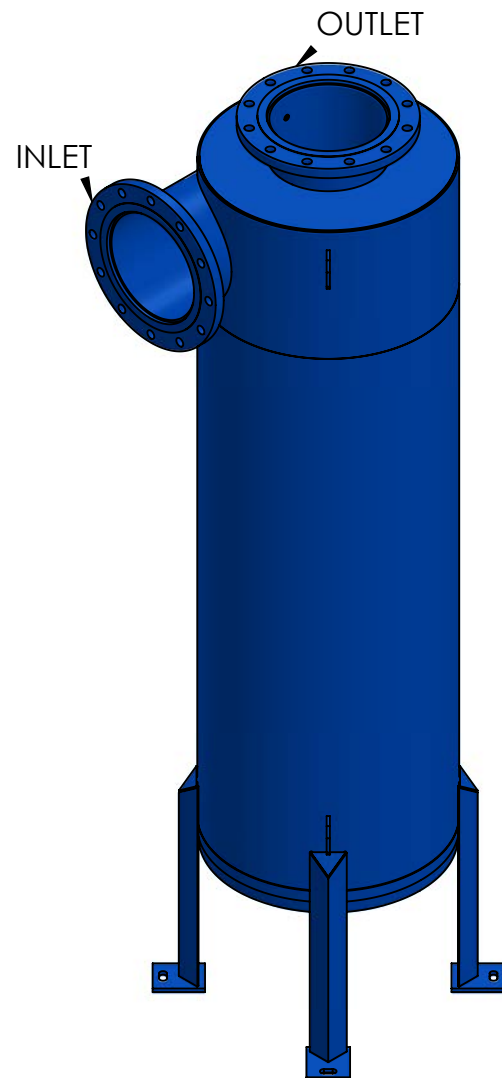
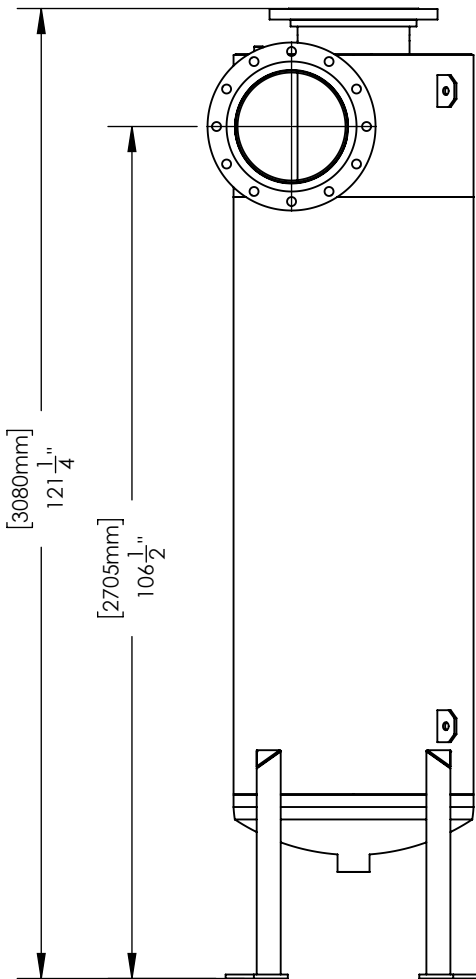
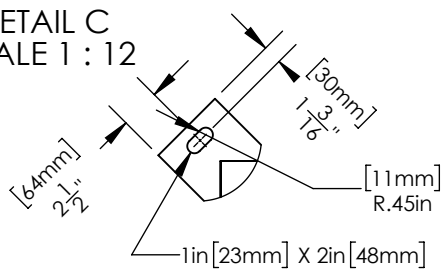

### NOTES:

1. INLET: 14" IPS (CLASS 150 FLANGE)
2. OUTLET: 14" IPS (CLASS 150 FLANGE)
3. MAXIMUM PRESSURE: 150 PSI @ 250F
4. FLOW RANGE: 4201-5100 GPM
5. PURGE: 3" IPS (NPT THREAD)
6. SHIPPING WEIGHT: 1385 LBS (628 KG)

PREPARED BY:  
PEI-CHI (JASON) WU

PART NUMBER:  
**CS-14T-FLG**

PAGE:  
**1**

RELEASED BY:

DATE:  
**12-12-2019**

REV:  
**B**



# CS-14T-FLG