

GENERAL WATER SYSTEMS

SEPARATOR

THIS DRAWING IS FOR SPATIAL CONSIDERATION ONLY, AND SUBJECT TO CHANGE W/O PREVIOUS NOTICE, DO NOT PRE-PLUMB TO THESE DIMENSIONS

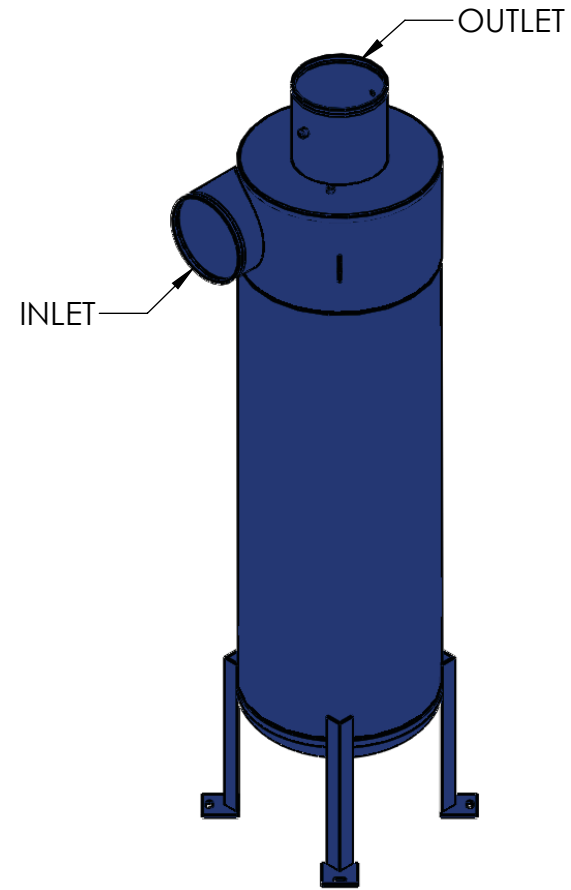
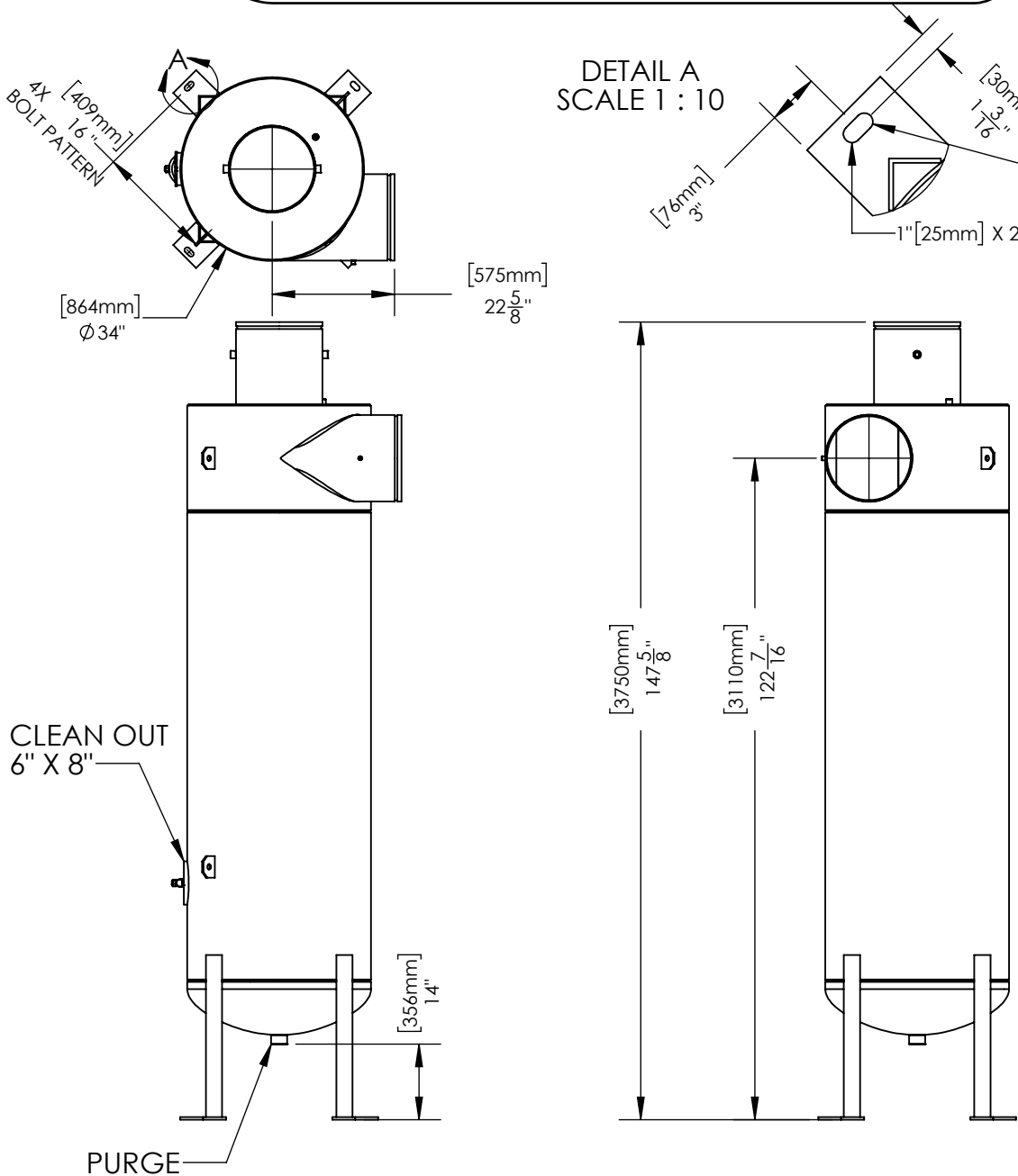

- NOTES:**
1. INLET: 16" IPS
 2. OUTLET: 16" IPS
 3. MAXIMUM PRESSURE: 150 PSI @ 250F
 4. FLOW RANGE: 5101-6600 GPM
 5. PURGE: 3" IPS (NPT THREAD)

PREPARED BY: HECTOR J. GUZMAN	REV A
RELEASED BY: TIM BOYLEN	DATE: 10/24/2020



General Water Systems | P.O Box 444 | Desert Hot Springs |CA | 92204
 www.gwslp.com | info@gwslp.com | 951.213.9506 | 386.255.3909
 *UNLESS OTHERWISE SPECIFIED - ALL DIMENSIONS ARE IN INCHES

CS-16T-GE