

GENERAL WATER SYSTEMS

THIS DRAWING IS FOR SPATIAL CONSIDERATION ONLY, AND SUBJECT TO CHANGE W/O PREVIOUS NOTICE, DO NOT PRE-PLUMB TO THESE DIMENSIONS

SEPARATOR

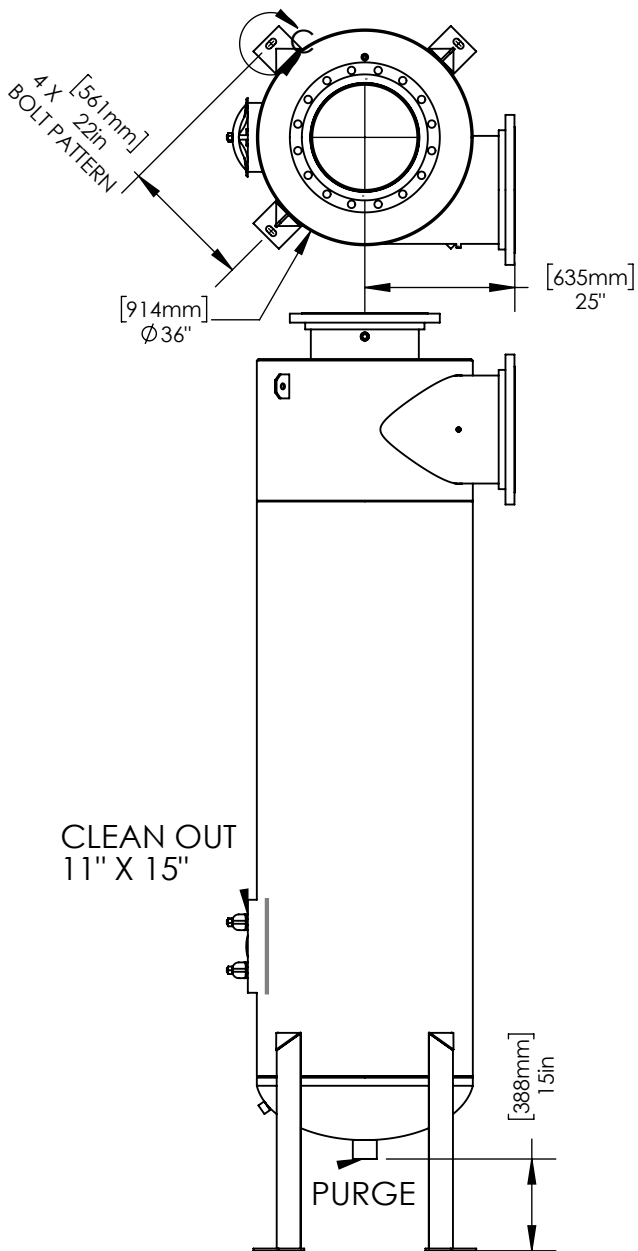

DETAIL C
SCALE 1 : 16

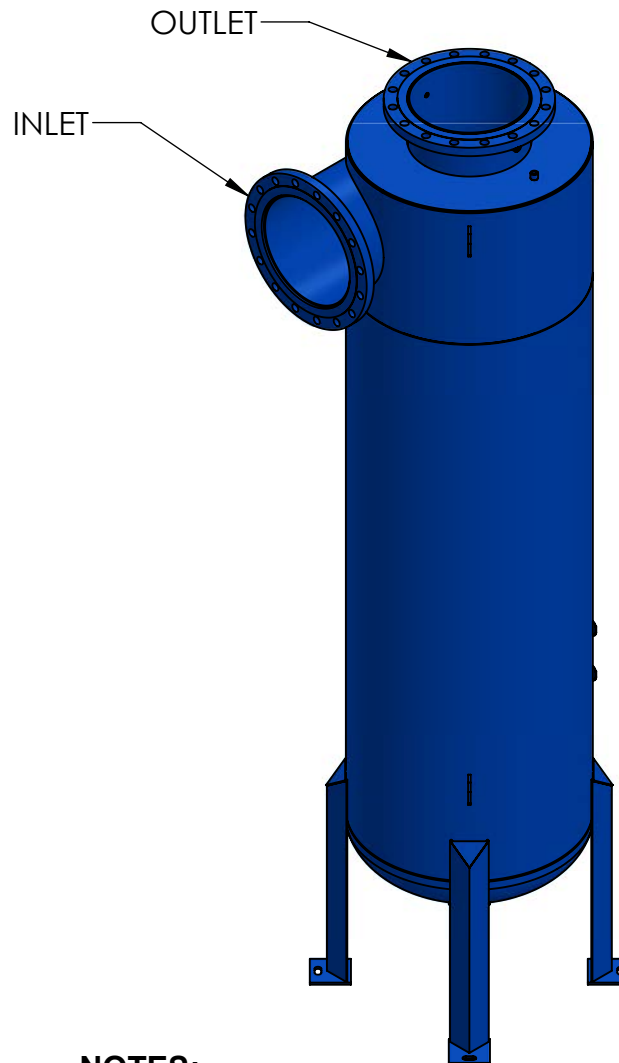
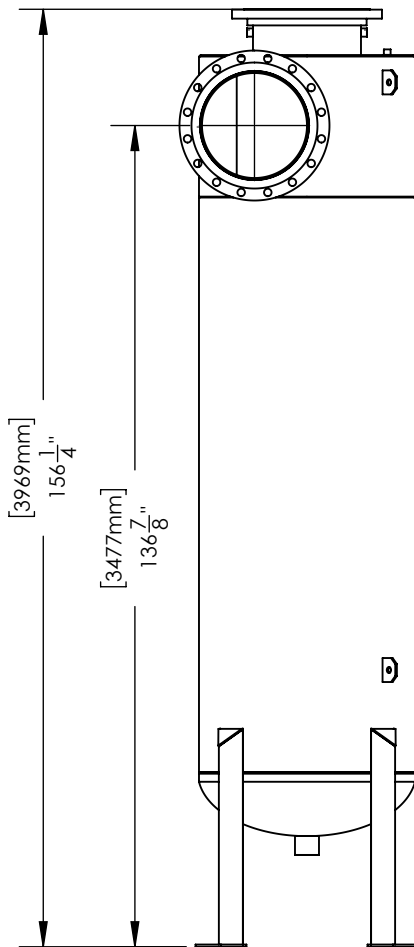
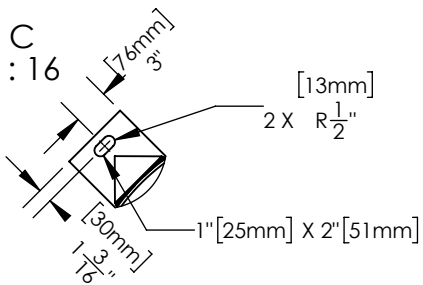

NOTES:

1. INLET: 18" IPS (CLASS 150 FLANGE)
2. OUTLET: 18" IPS (CLASS 150 FLANGE)
3. MAXIMUM PRESSURE: 150 PSI @ 250F
4. FLOW RANGE: 6601-8400 GPM
5. PURGE: 3" IPS (NPT THREAD)
6. SHIPPING WEIGHT: 2350 LBS (1066 KG)

*UNLESS OTHERWISE SPECIFIED - ALL DIMENSIONS ARE IN INCHES

PREPARED BY: PEI-CHI (JASON) WU	PART NUMBER: CS-18T-FLG	PAGE: 1
RELEASED BY:	DATE: 12-12-2019	REV: B



CS-18T-FLG