

GENERAL WATER SYSTEMS

SEPARATOR

THIS DRAWING IS FOR SPATIAL CONSIDERATION ONLY, AND SUBJECT TO CHANGE W/O PREVIOUS NOTICE, DO NOT PRE-PLUMB TO THESE DIMENSIONS

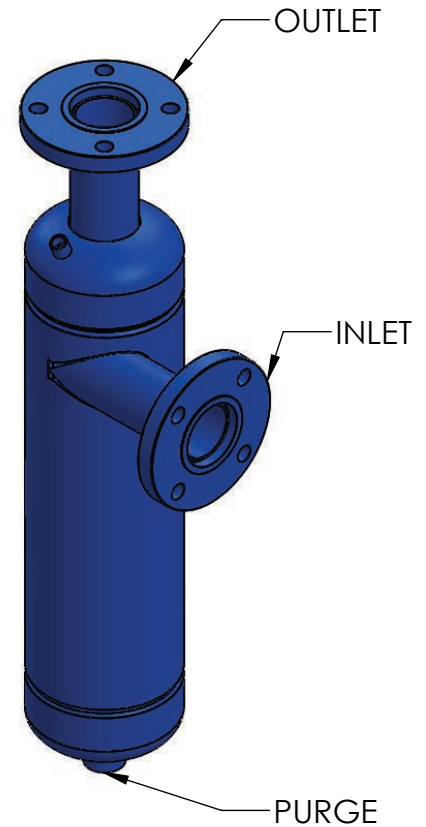
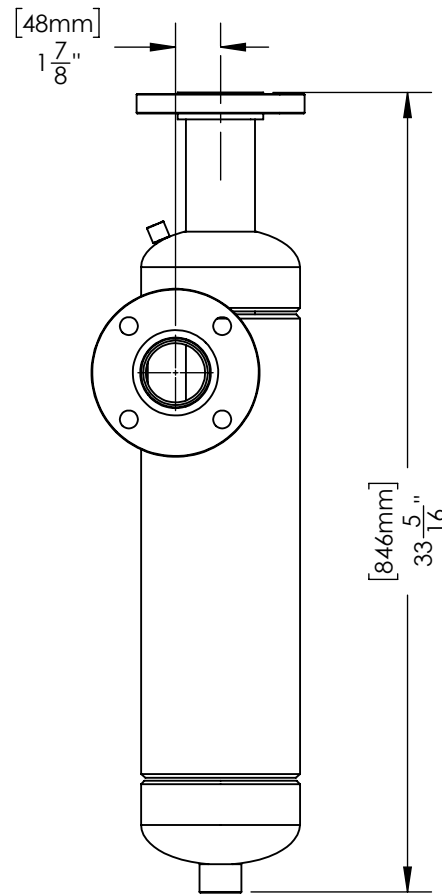
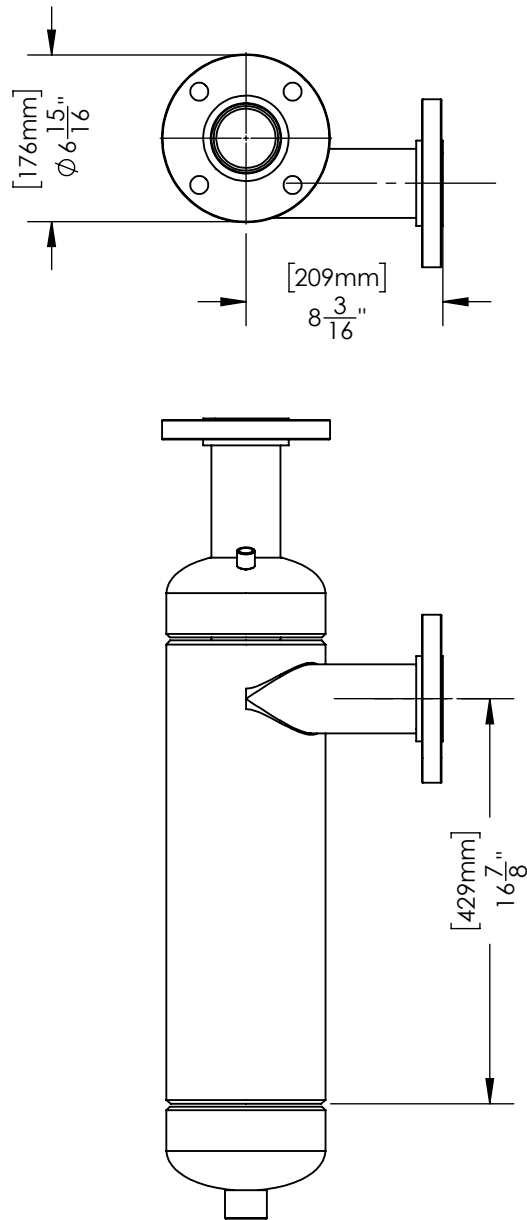

NOTES

1. **INLET:** 2-1/2" IPS (CLASS 150 FLANGE)
2. **OUTLET:** 2-1/2" IPS (CLASS 150 FLANGE)
3. **MAX PRESSURE:** 150 PSI @ 250F
4. **FLOW RANGE:** 126-180 GPM
5. **PURGE SIZE:** 1" IPS(NPT THREAD)

PREPARED BY:
HECTOR J. GUZMAN

REV

A

RELEASED BY:

TIM BOYLEN

DATE:

12/16/2020



General Water Systems | P.O. Box 444 | Desert Hot Springs | CA | 92204
www.gwslp.com | info@gwslp.com | 951.213.9506 | 386.255.3909

*UNLESS OTHERWISE SPECIFIED -
ALL DIMENSIONS ARE IN INCHES

CS-2.5T-FLG