

# GENERAL WATER SYSTEMS

THIS DRAWING IS FOR SPATIAL CONSIDERATION ONLY, AND SUBJECT TO CHANGE W/O PREVIOUS NOTICE, DO NOT PRE-PLUMB TO THESE DIMENSIONS

## SEPARATOR

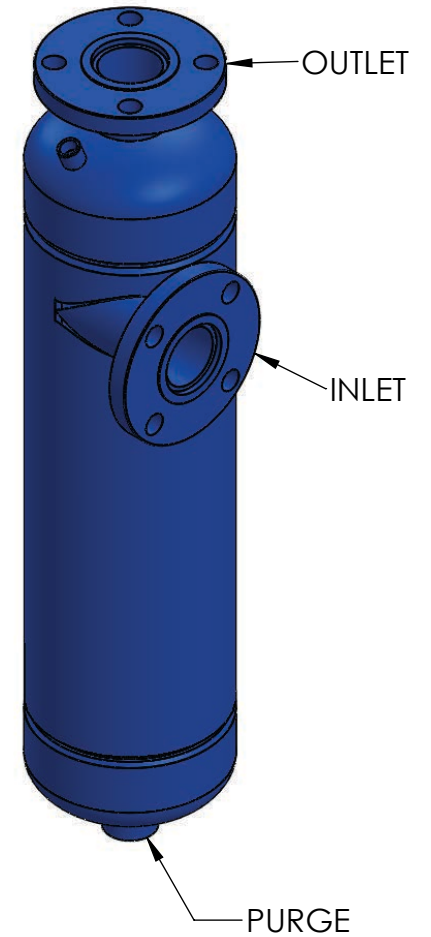
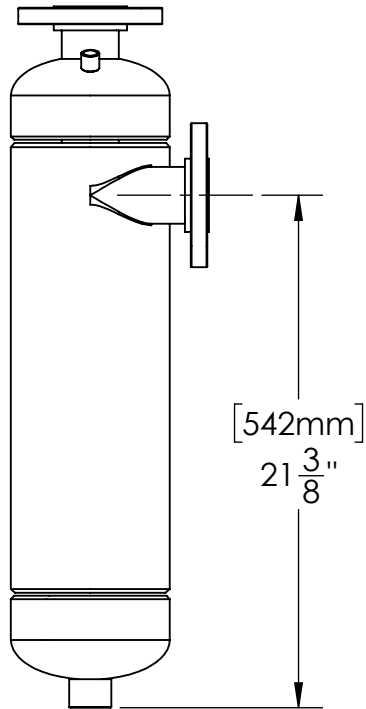
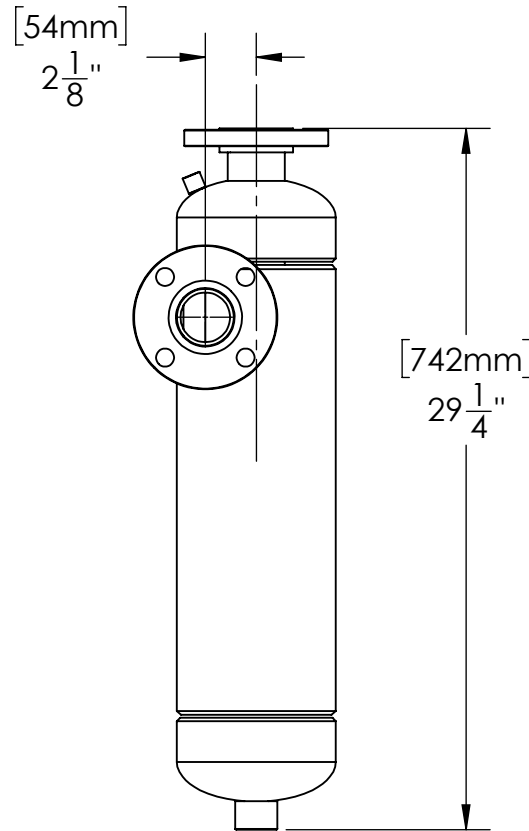
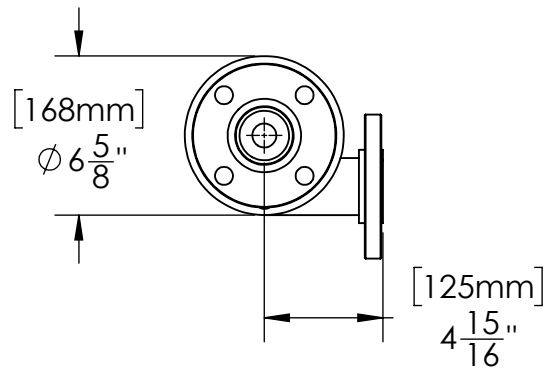

### NOTES

1. **INLET:** 2" IPS (CLASS 150 FLANGE)
2. **OUTLET:** 2" IPS (CLASS 150 FLANGE)
3. **MAX PRESSURE:** 150 PSI @ 250F
4. **FLOW RANGE:** 76-125 GPM
5. **PURGE SIZE:** 1" IPS(NPT THREAD)

|                                  |                            |
|----------------------------------|----------------------------|
| PREPARED BY:<br>HECTOR J. GUZMAN | REV<br><b>A</b>            |
| RELEASED BY:<br>TIM BOYLEN       | DATE:<br><b>12/16/2020</b> |



General Water Systems | P.O Box 444 | Desert Hot Springs |CA | 92204  
 www.gwslp.com | info@gwslp.com |951.213.9506| 386.255.3909  
 \*UNLESS OTHERWISE SPECIFIED -  
 ALL DIMENSIONS ARE IN INCHES

**CS-2T-FLG**