

GENERAL WATER SYSTEMS

SEPARATOR

THIS DRAWING IS FOR SPATIAL CONSIDERATION ONLY, AND SUBJECT TO CHANGE W/O PREVIOUS NOTICE, DO NOT PRE-PLUMB TO THESE DIMENSIONS

NOTES:

1. INLET: 3" NPT
2. OUTLET: 3" NPT
3. FLOW RANGE: 181-280 GPM
4. MAX PRESSURE: 150 PSI @ 250F
5. PURGE SIZE: 1" IPS(NPT THREAD)
6. SHIPPING WEIGHT: 110 LBS, (50 KG)

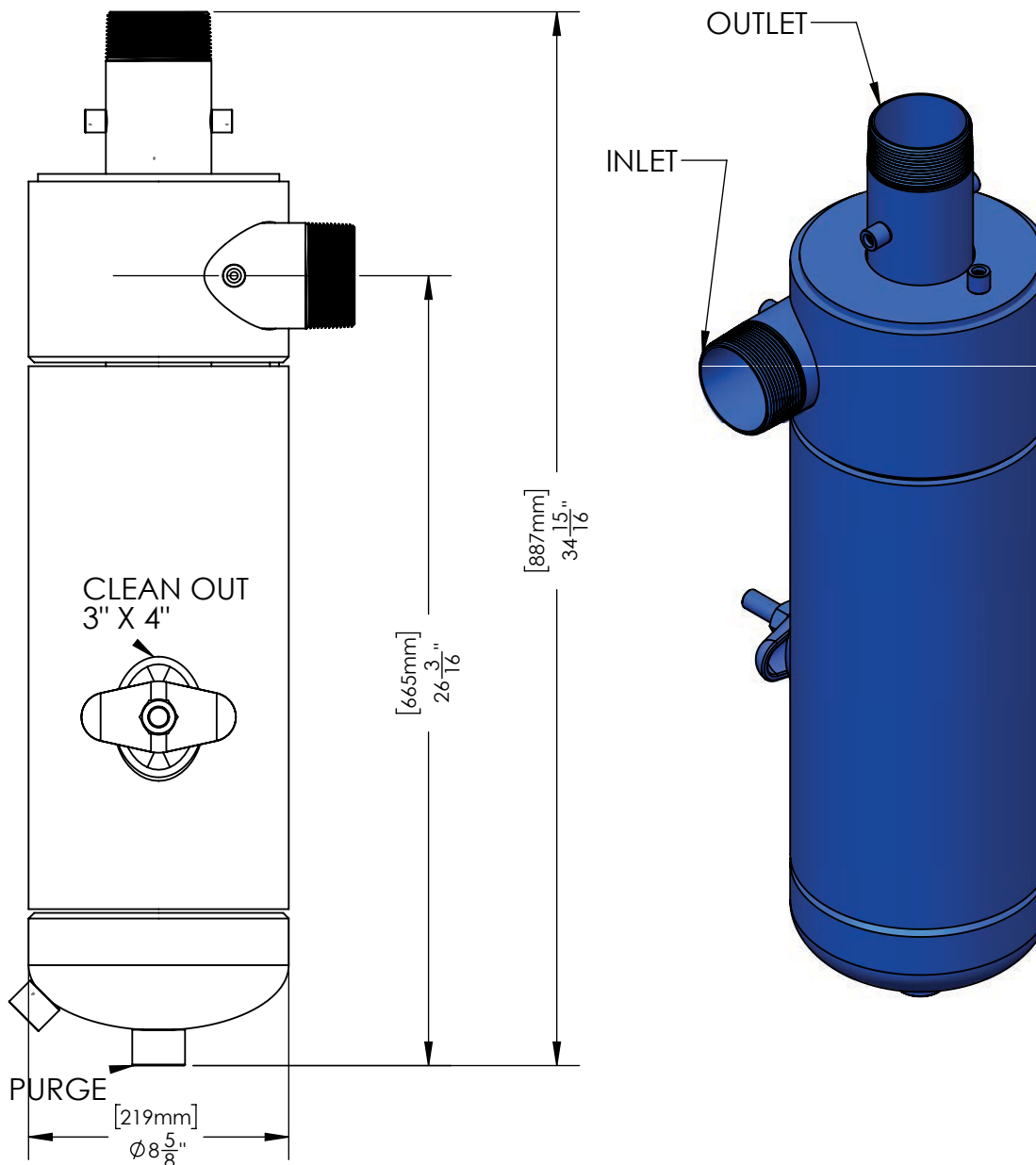

General Water Systems | P. O. Box 444 | Desert Hot Spring | CA | 92204
www.gwslp.com | info@gwslp.com | 951.213.9506 | 386.255.3909

PREPARED BY: PEI-CHI(JASON) WU	PART NUMBER: P7847	PAGE: 1
RELEASED BY:	DATE: 12-12-2019	REV: B

*UNLESS OTHERWISE SPECIFIED - ALL DIMENSIONS ARE IN INCHES

CS-3T-THD