

SEPARATOR

GENERAL WATER SYSTEMS

THIS DRAWING IS FOR SPATIAL CONSIDERATION ONLY, AND SUBJECT TO CHANGE W/O PREVIOUS NOTICE, DO NOT PRE-PLUMB TO THESE DIMENSIONS

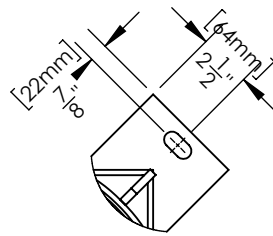
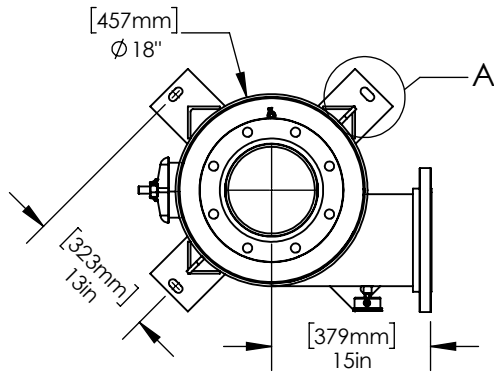

DETAIL A

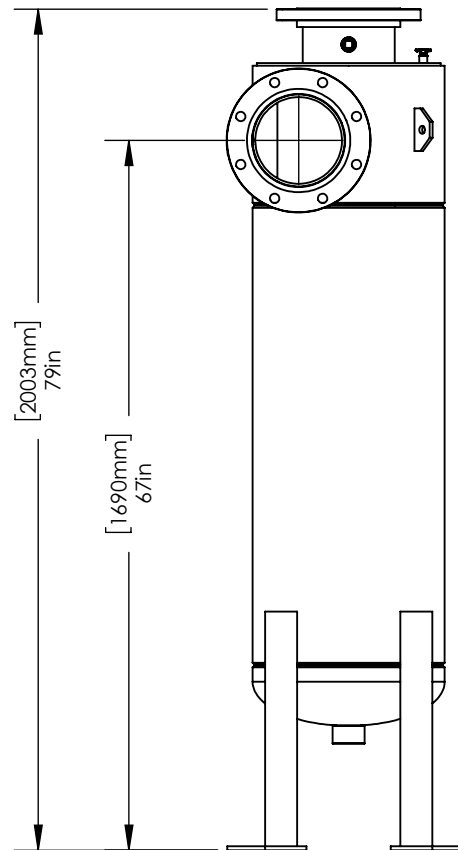
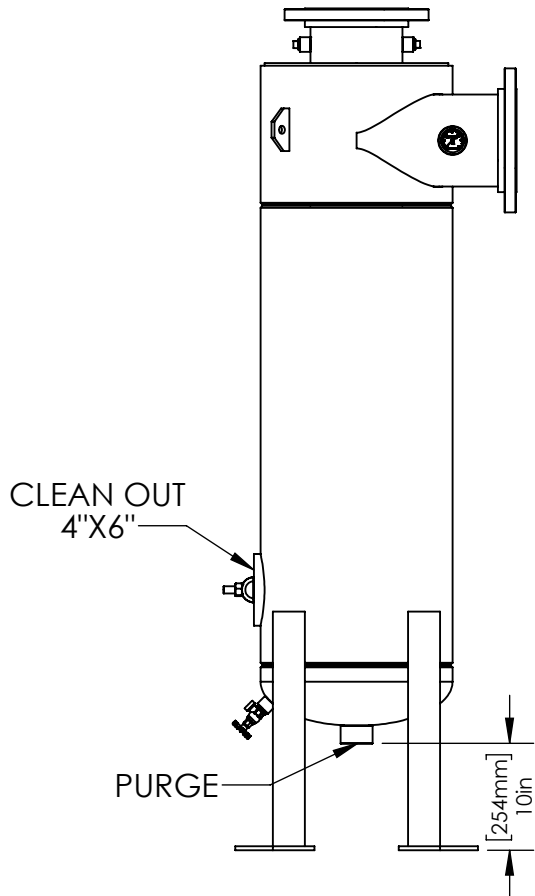
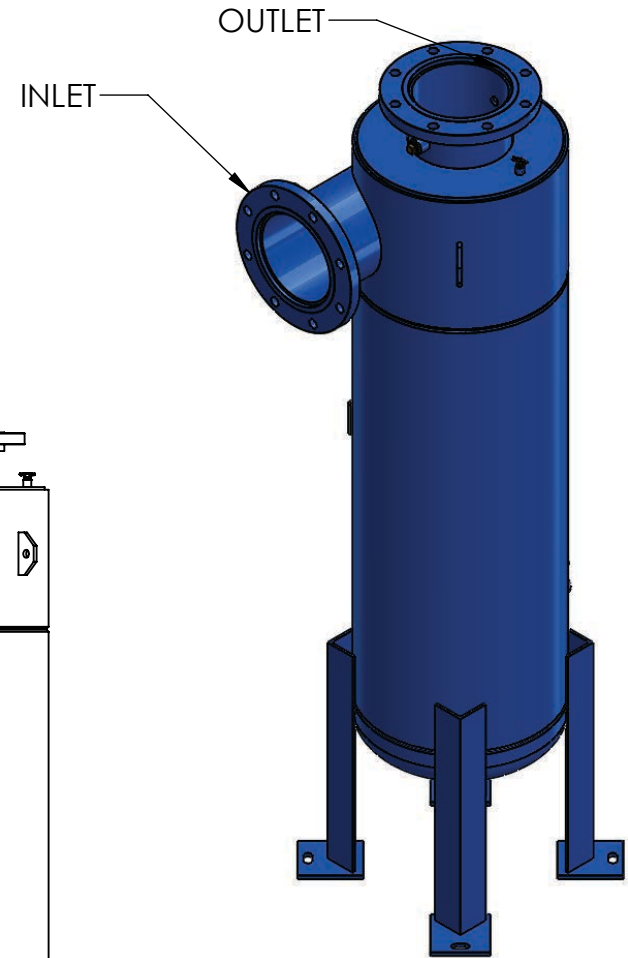

NOTES

1. INLET: 8" IPS (CLASS 150 FLANGE)
2. OUTLET: 8" IPS (CLASS 150 FLANGE)
3. MAXIMUM PRESSURE: 150 PSI @ 250F
4. FLOW RANGE: 1101-1870GPM
5. PURGE: 2" IPS (NPT THREAD)
6. SHIPPING WEIGHT: 680 LBS (308.44KG)

PREPARED BY: KYLE MCCARTHY	*UNLESS OTHERWISE SPECIFIED - ALL DIMENSIONS ARE IN INCHES
PART NUMBER: CS-8T-FLG	DATE: 7/23/2020



CS-8T-FLG