

This drawing is for spatial consideration only. Do not pre-plumb to these dimensions.

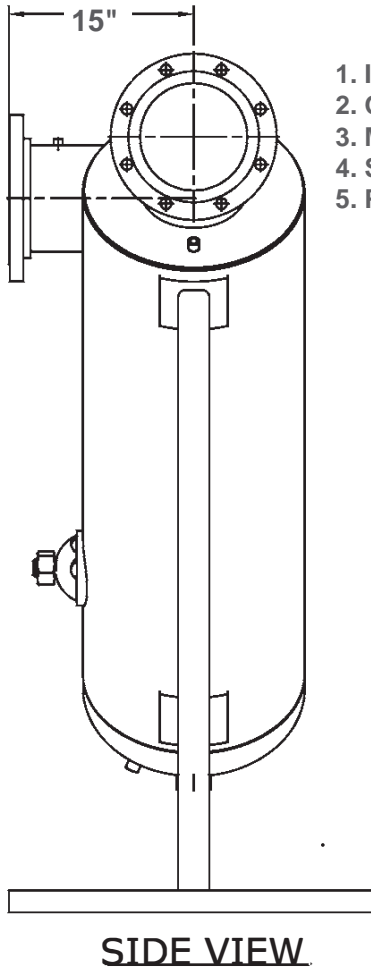

NOTES

1. INLET IS 8" PIPE (150# FLANGE)
2. OUTLET IS 8" PIPE (150# FLANGE)
3. MAXIMUM PRESSURE: 150 PSI @ 250 DEG F
4. SPECIFIED FLOW RATE: 1101 - 1870 GPM
5. PURGE IS 2" PIPE (NPT THREAD)

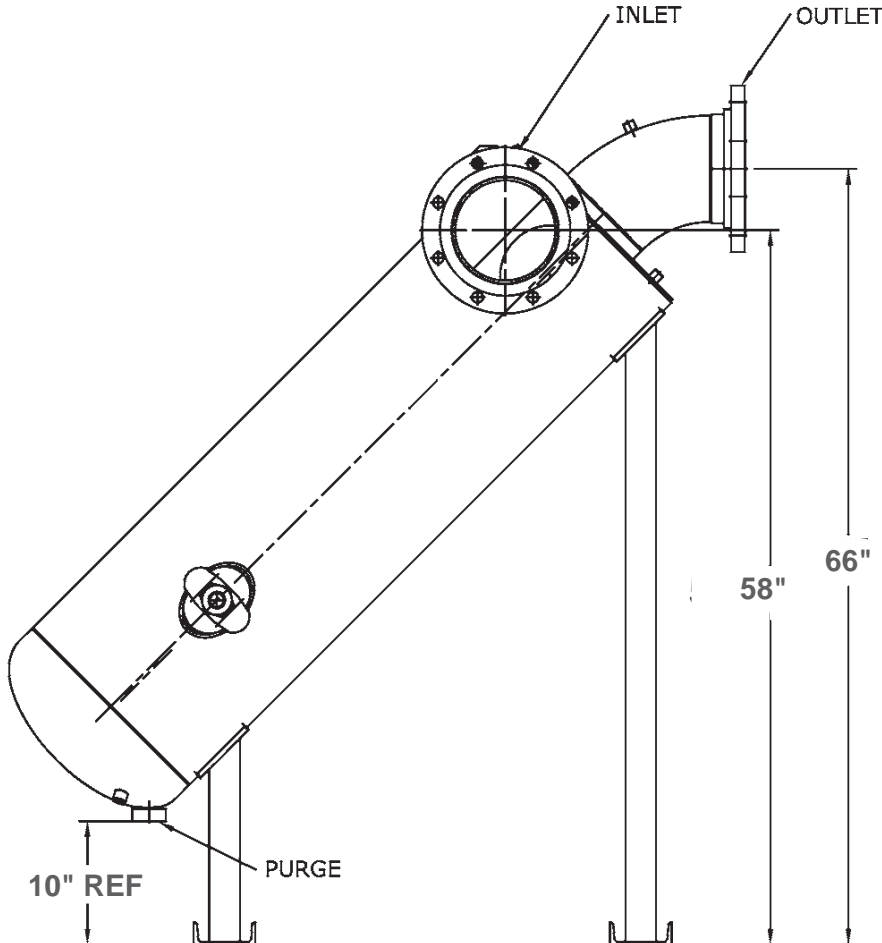
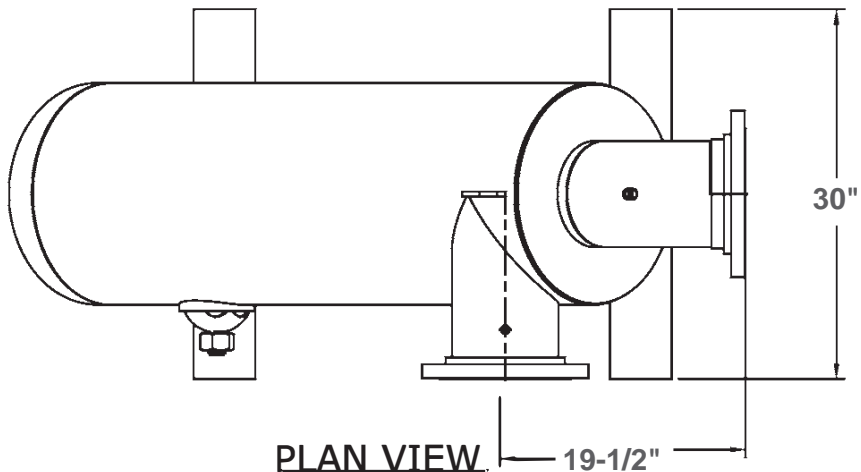

THIS DOCUMENT MAY CONTAIN PROPRIETARY INFORMATION. IT MAY NOT BE REPRODUCED OR TRANSFERRED TO OTHERS OR USED FOR MANUFACTURING OR ANY OTHER PURPOSE WITHOUT PRIOR WRITTEN PERMISSION.		GENERAL WATER SYSTEMS			
		CS-8T-LPF			
DRAWN	R. Kazanjy	DATE	1.6.16	MATERIAL:	CARBON STEEL
APPRD	-			DRAWING NO.	-
		WEIGHT: 560 lbs. (254 kg.)		SCALE	
				SIZE	A
				REV.	A
					SHEET 1 OF 1