

THIS DRAWING IS FOR SPATIAL CONSIDERATION ONLY, AND SUBJECT TO CHANGE W/O PREVIOUS NOTICE, DO NOT PRE-PLUMB TO THESE DIMENSIONS

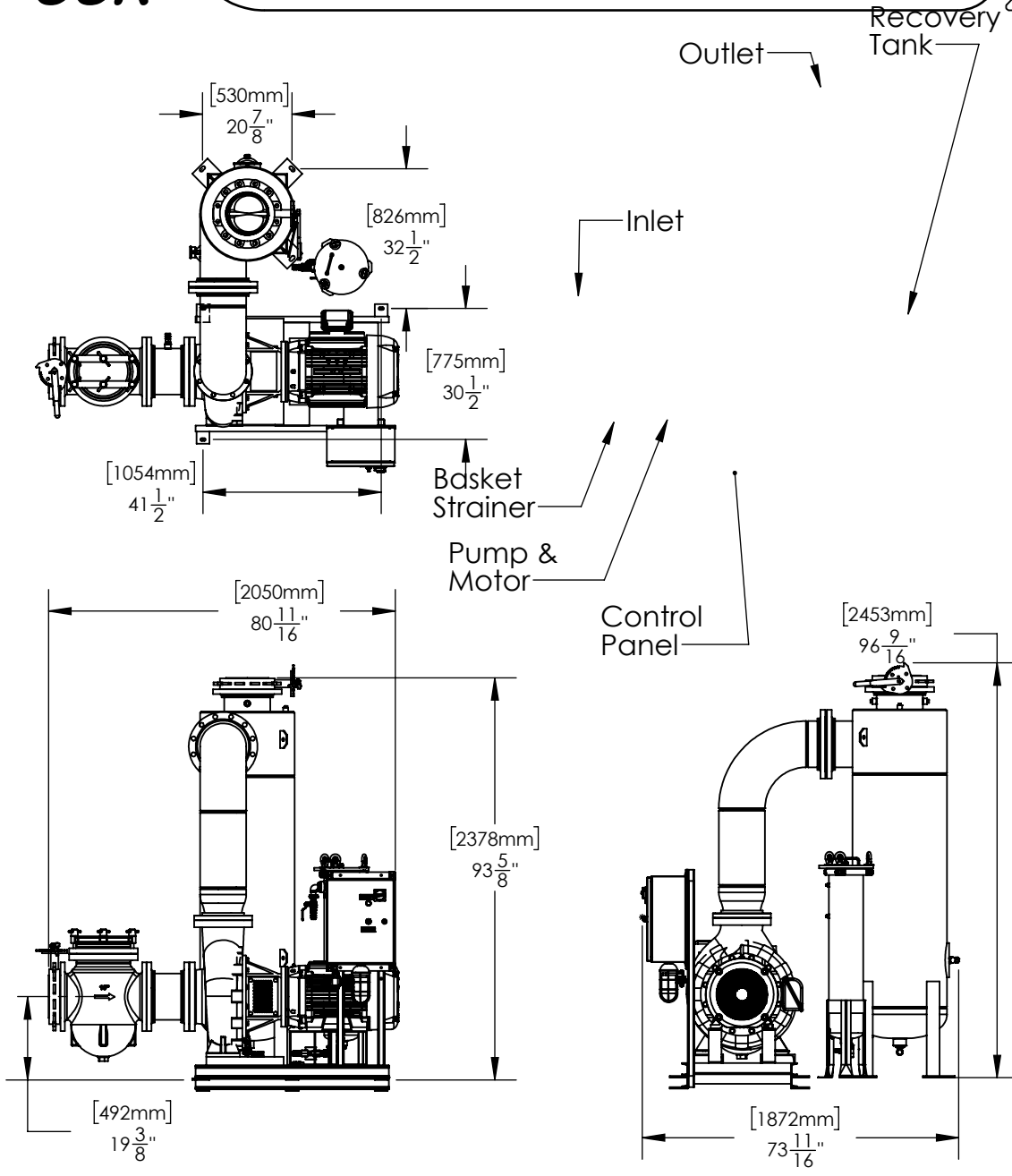

CSR1001-LH			
Operating Point	2950 GPM (US) @ 40' TDH		
Separator - Size & Style	CS-10T-FLG, Carbon Steel, Powder Coated		
Frame Construction	Carbon Steel (Welded), Powder Coated		
Pipe Assy - Construction	Carbon Steel (Welded), Powder Coated		

ELECTRICAL - Motor & System			
Horsepower (HP)	50		
Power - Volts / Hz	460/60	575/60	230/60
RPM	1750	1750	1750
Motor Amperage	65	52	130
System Total Amperage	67	54	132

PUMP	
Installation	Flooded Suction Required
Case Material	Cast Iron
Impeller Material	304
Mechanical Seal	EPDM - Carbon / Ceramic

BASKET STRAINER (Optional)	
Body Construction	Cast Iron
Strainer Mesh	Stainless Steel 1/4" perforations
Connection - Type & Size	10" FLG (150#)

CONTROL PANEL (UL Listed & Labeled. Manufactured to UL 508A)	
Enclosure (UL listed & CSA approved)	NEMA 4 (STD) - Carbon Steel, Powder Coated NEMA 4X (Optional) - 304
Electrical Components (UL listed & CSA approved)	Thermal Overload Starter, HOA, XFMR, "RUN" Light, Door Disconnect, Contactor

PROCESS INLET	
Connection - Type & Size	10" FLG (150#) - Butterfly Valve

PROCESS OUTLET	
Connection - Type & Size	10" FLG (150#) - Butterfly Valve

PURGE - RT (Recovery Tank)	
Recovery Tank	RT-1.5
Connection Type	RTM-20

PRESSURE - Maximum Operating	
Pump Inlet	100 psi (6.9 bar)
Vessel	150 psi (10.3 bar)

TEMPERATURE - Maximum Operating	
System	34°F - 122°F (1°C - 50°C)

WEIGHTS	DRY	SHIPPING	OPERATING
	lbs (kg)	3471 (1574)	3921 (1779)

*UNLESS OTHERWISE SPECIFIED - ALL DIMENSIONS ARE IN INCHES

PREPARED BY: JASON WU PAGE: 1
 RELEASED BY: BOB KAZANJY DATE: 12/20/2018 REV: A



General Water Systems | P.O. Box 444 | Desert Hot Spring | CA | 92204
 www.gwslp.com | info@gwslp.com | 951.213.9506 | 386.255.3909

CSR1001-LH