

THIS DRAWING IS FOR SPATIAL CONSIDERATION ONLY, AND SUBJECT TO CHANGE W/O PREVIOUS NOTICE, DO NOT PRE-PLUMB TO THESE DIMENSIONS

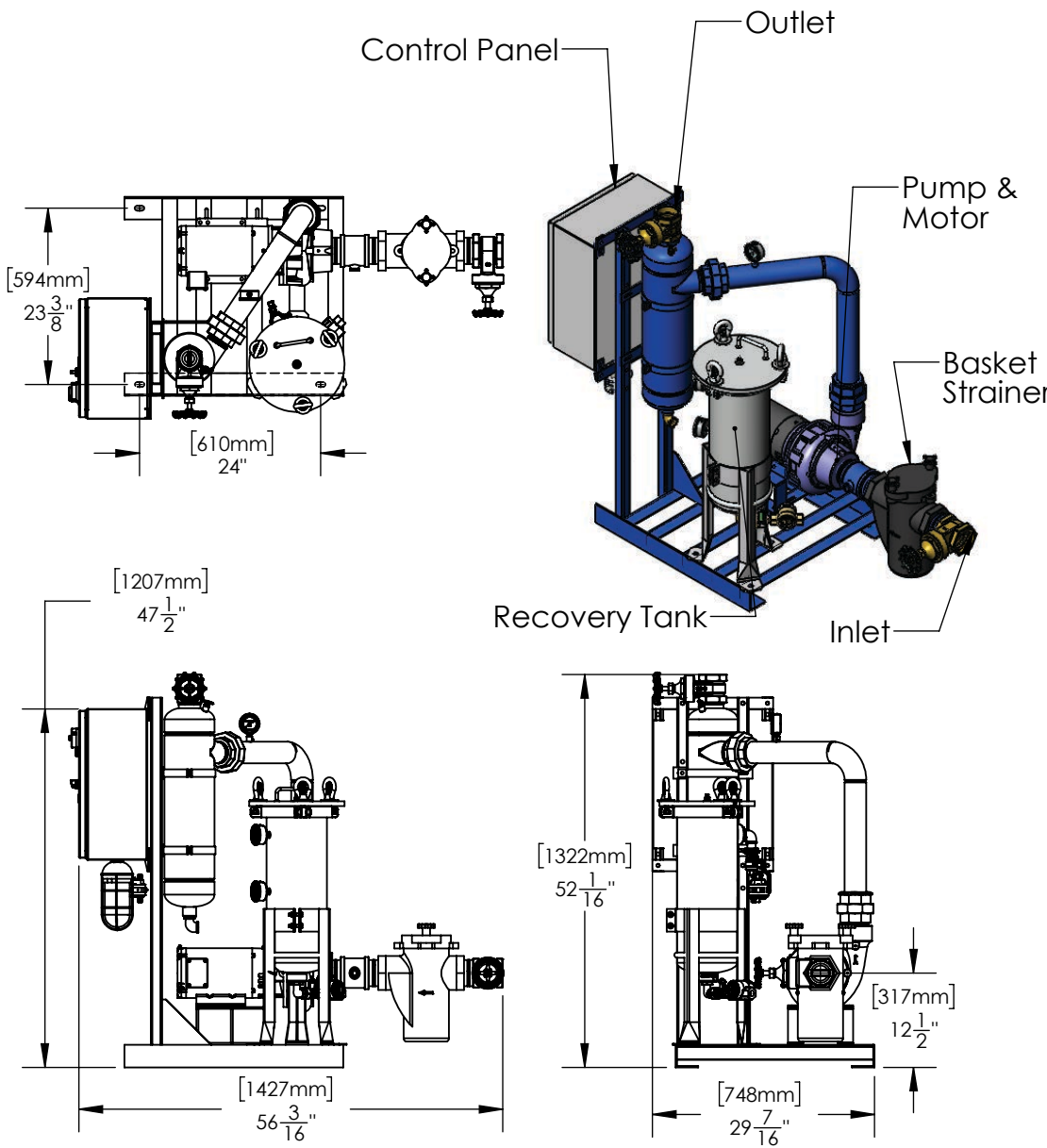

CSR251-LH

Operating Point	180 GPM (US) @ 40' TDH			
Separator - Size & Style	CS-2.5T-THD, Carbon Steel, Powder Coated			
Frame Construction	Carbon Steel (Welded), Powder Coated			
Pipe Assy - Construction	Carbon Steel (Welded), Powder Coated			

ELECTRICAL - Motor & System

Horsepower (HP)	3			
Power - Volts / Hz	460/60	575/60	230/60	208/60
RPM	1750	1750	1750	1750
Motor Amperage	4.8	3.9	9.6	10.5
System Total Amperage	6.8	5.9	11.6	12.5

PUMP

Installation	Flooded Suction Required
Case Material	Cast Iron
Impeller Material	Cast Iron
Mechanical Seal	Buna - Carbon / Ceramic

BASKET STRAINER

Body Construction	Cast Iron
Strainer Mesh	Stainless Steel with 1/4" perforations
Connection - Type & Size	Female NPT 3"

CONTROL PANEL (UL Listed & Labeled. Manufactured to UL 508A)

Enclosure (UL listed & CSA approved)	NEMA 4 (STD) - Carbon Steel, Powder Coated NEMA 4X (Optional) - 304
Electrical Components (UL listed & CSA approved)	Thermal Overload Starter, HOA, XFMR, "RUN" Light, Door Disconnect, Contactor

PROCESS INLET

Connection - Type & Size	NPT 3" - Gate Valve
--------------------------	---------------------

PROCESS OUTLET

Connection - Type & Size	NPT 2.5" - Gate Valve
--------------------------	-----------------------

PURGE - RT (Recovery Tank)

RT Size	RT-1
RT Connection Type	RTM-10

PRESSURE - Maximum Operating

Pump Inlet	100 psi (6.9 bar)
Vessel	150 psi (10.3 bar)

TEMPERATURE - Maximum Operating

System	34°F - 122°F (1°C - 50°C)
--------	---------------------------

WEIGHTS	DRY	SHIPPING	OPERATING
lbs (kg)	468 (212)	578 (262)	550 (250)

*UNLESS OTHERWISE SPECIFIED - ALL DIMENSIONS ARE IN INCHES

PREPARED BY: VINH QUAN TRAN	PAGE: 1
RELEASED BY: BOB KAZANJY	DATE: 12/20/2018
	REV: A



General Water Systems | P. O. Box 444 | Desert Hot Spring | CA | 92204
www.gwslp.com | info@gwslp.com | 951.213.9506 | 386.255.3909

CSR251-LH