

THIS DRAWING IS FOR SPATIAL CONSIDERATION ONLY, AND SUBJECT TO CHANGE W/O PREVIOUS NOTICE, DO NOT PRE-PLUMB TO THESE DIMENSIONS

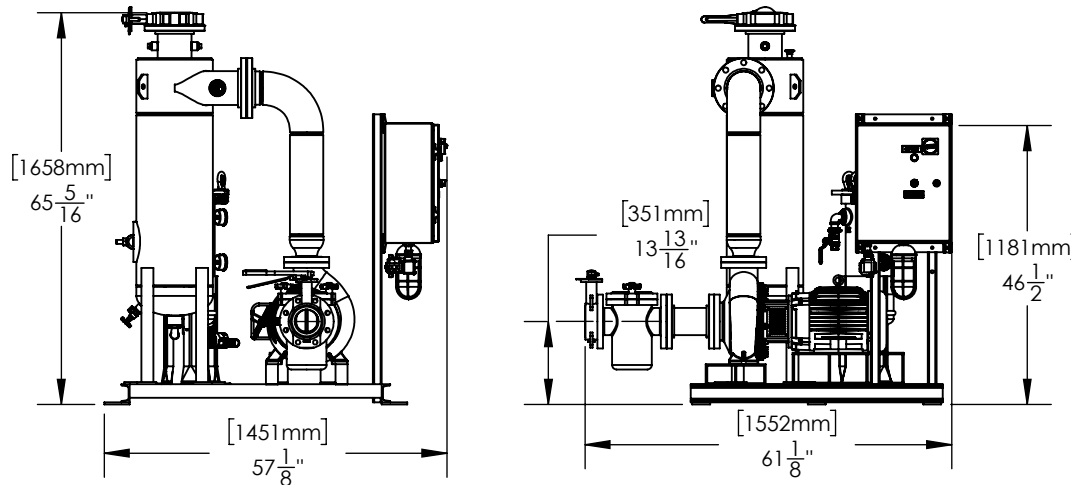
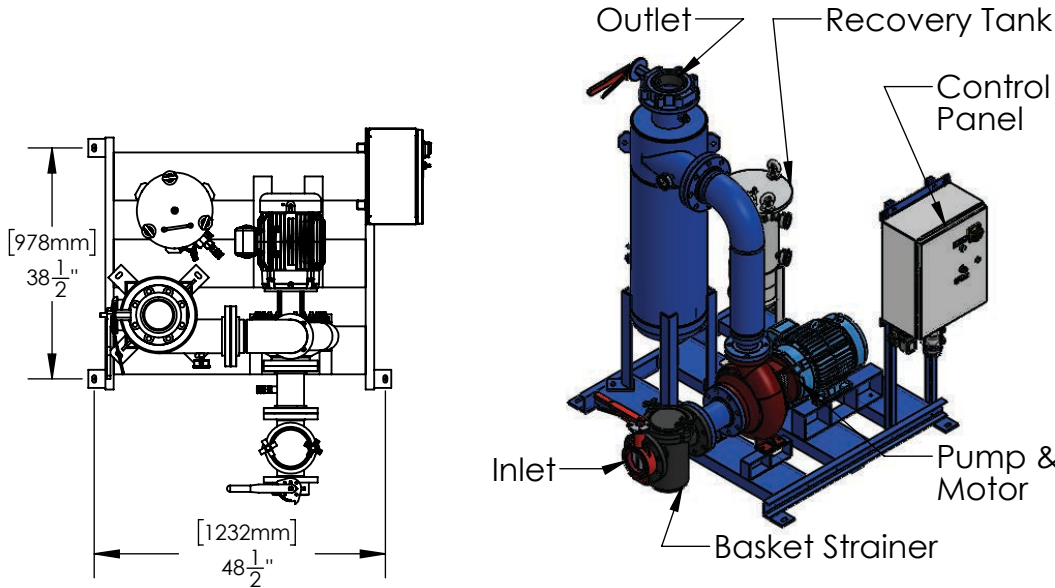

CSR500-LH

Operating Point	525 GPM (US) @ 40' TDH			
Separator - Size & Style	CS-5T-FLG, Carbon Steel, Powder Coated			
Frame Construction	Carbon Steel (Welded), Powder Coated			
Pipe Assy - Construction	Carbon Steel (Welded), Powder Coated			

ELECTRICAL - Motor & System

Horsepower (HP)	10			
Power - Volts / Hz	460/60	575/60	230/60	208/60
RPM	1750	1750	1750	1750
Motor Amperage	14	11	28	30.8
System Total Amperage	16	13	30	32.8

PUMP

Installation	Flooded Suction Required
Case Material	Cast Iron
Impeller Material	304
Mechanical Seal	EPDM - Carbon / Ceramic

BASKET STRAINER (Optional)

Body Construction	Cast Iron
Strainer Mesh	Stainless Steel with 1/4" perforations
Connection - Type & Size	4" FLG (150#)

CONTROL PANEL (UL Listed & Labeled. Manufactured to UL 508A)

Enclosure (UL listed & CSA approved)	NEMA 4 (STD) - Carbon Steel, Powder Coated NEMA 4X (Optional) - 304
Electrical Components (UL listed & CSA approved)	Thermal Overload Starter, HOA, XFMR, "RUN" Light, Door Disconnect, Contactor

PROCESS INLET

Connection - Type & Size	4" FLG (150#) - Butterfly Valve
--------------------------	---------------------------------

PROCESS OUTLET

Connection - Type & Size	5" FLG (150#) - Butterfly Valve
--------------------------	---------------------------------

PURGE - RT (Recovery Tank)

RT Size	RT-1
RT Connection Type	RTM-10

PRESSURE - Maximum Operating

Pump Inlet	100 psi (6.9 bar)
Vessel	150 psi (10.3 bar)

TEMPERATURE - Maximum Operating

System	34°F - 122°F (1°C - 50°C)
--------	---------------------------

WEIGHTS	DRY	SHIPPING	OPERATING
lbs (kg)	1270 (576)	1458 (661)	1583 (718)

*UNLESS OTHERWISE SPECIFIED - ALL DIMENSIONS ARE IN INCHES

PREPARED BY: VINH QUAN TRAN	PAGE: 1
RELEASED BY: BOB KAZANJY	DATE: 12/20/2018
	REV: A

