

**THIS DRAWING IS FOR SPATIAL CONSIDERATION ONLY, AND SUBJECT TO CHANGE W/O PREVIOUS NOTICE, DO NOT PRE-PLUMB TO THESE DIMENSIONS**

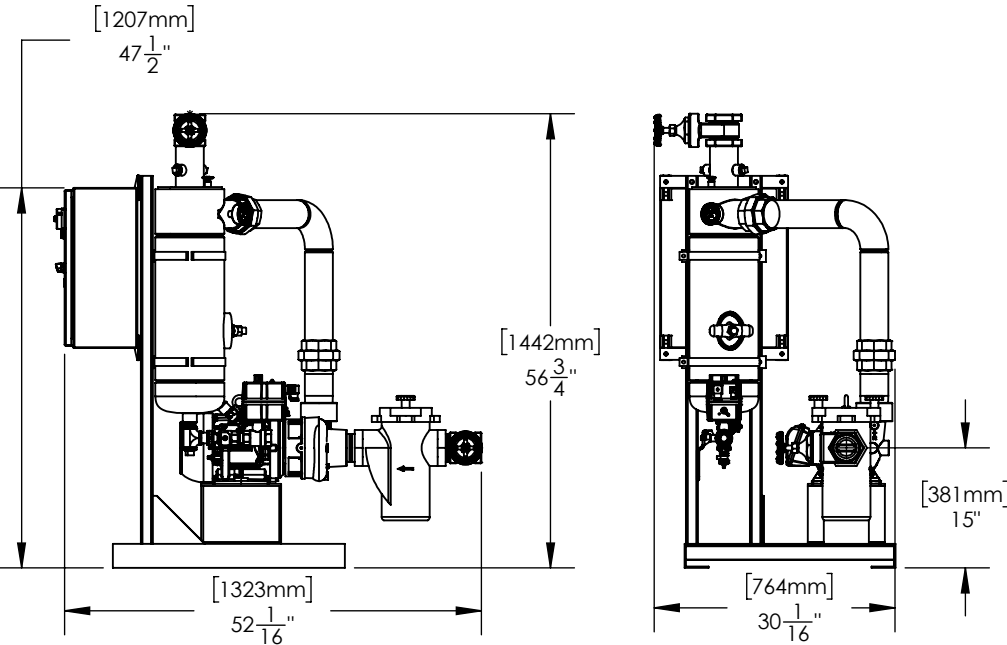
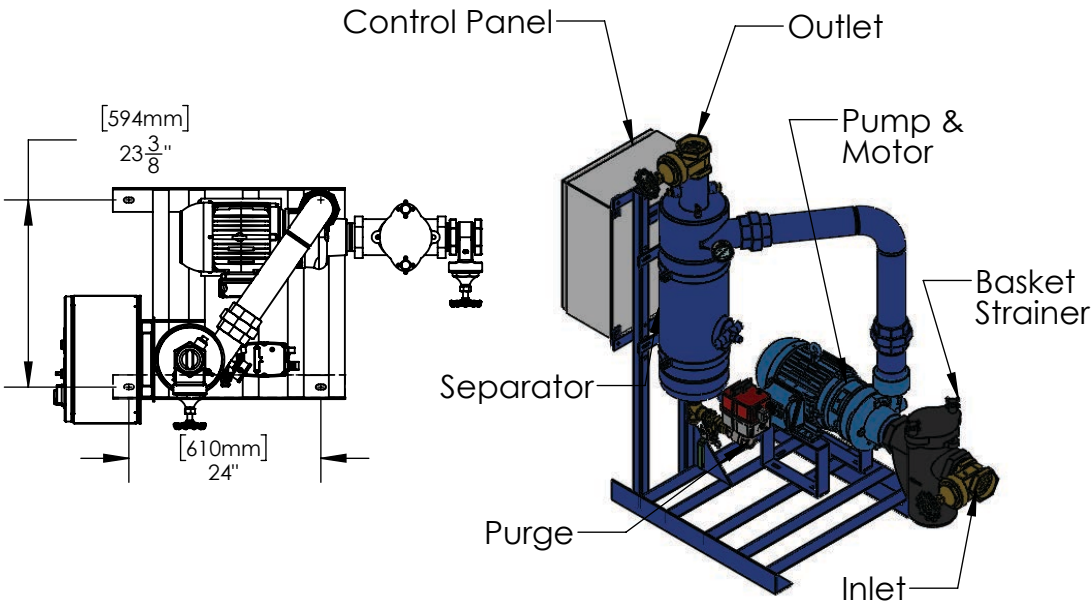

### CSS301-LH

Operating Point	280 GPM (US) @ 40' TDH			
Separator - Size & Style	CS-3T-THD, Carbon Steel, Powder Coated			
Frame Construction	Carbon Steel (Welded), Powder Coated			
Pipe Assy - Construction	Carbon Steel (Welded), Powder Coated			

#### ELECTRICAL - Motor & System

Horsepower (HP)	5			
Power - Volts / Hz	460/60	575/60	230/60	208/60
RPM	3500	3500	3500	3500
Motor Amperage	7.6	6.1	15.2	16.7
System Total Amperage	9.6	8.1	17.2	18.7

#### PUMP

Installation	Flooded Suction Required
Case Material	Cast Iron
Impeller Material	Cast Iron
Mechanical Seal	Buna - Carbon / Ceramic

#### BASKET STRAINER (Optional)

Body Construction	Cast Iron
Strainer Mesh	Stainless Steel with 1/4" perforations
Connection - Type & Size	Female NPT 3"

#### CONTROL PANEL (UL Listed & Labeled. Manufactured to UL 508A)

Enclosure (UL listed & CSA approved)	NEMA 4 (STD) - Carbon Steel, Powder Coated NEMA 4X (Optional) - 304
Electrical Components (UL listed & CSA approved)	Thermal Overload Starter, HOA, XFMR, "RUN" Light, Door Disconnect, Contactor, Purge Timer

#### PROCESS INLET

Connection - Type & Size	NPT 3" - Gate Valve
--------------------------	---------------------

#### PROCESS OUTLET

Connection - Type & Size	NPT 3" - Gate Valve
--------------------------	---------------------

#### PURGE - MBV (Motorized Ball Valve)

Actuator Motor	24-240V AC/DC
Connection Type	Female NPT 1"

#### PRESSURE - Maximum Operating

Pump Inlet	100 psi (6.9 bar)
Vessel	150 psi (10.3 bar)

#### TEMPERATURE - Maximum Operating

System	34°F - 122°F (1°C - 50°C)
--------	---------------------------

WEIGHTS	DRY	SHIPPING	OPERATING
lbs (kg)	550 (249)	660 (299)	617 (280)

\*UNLESS OTHERWISE SPECIFIED - ALL DIMENSIONS ARE IN INCHES

### CSS301-LH

PREPARED BY: VINH	PAGE: 1
RELEASED BY: BOB KAZANJY	DATE: 01/02/2019
	REV: A