

THIS DRAWING IS FOR SPATIAL CONSIDERATION ONLY, AND SUBJECT TO CHANGE W/O PREVIOUS NOTICE, DO NOT PRE-PLUMB TO THESE DIMENSIONS

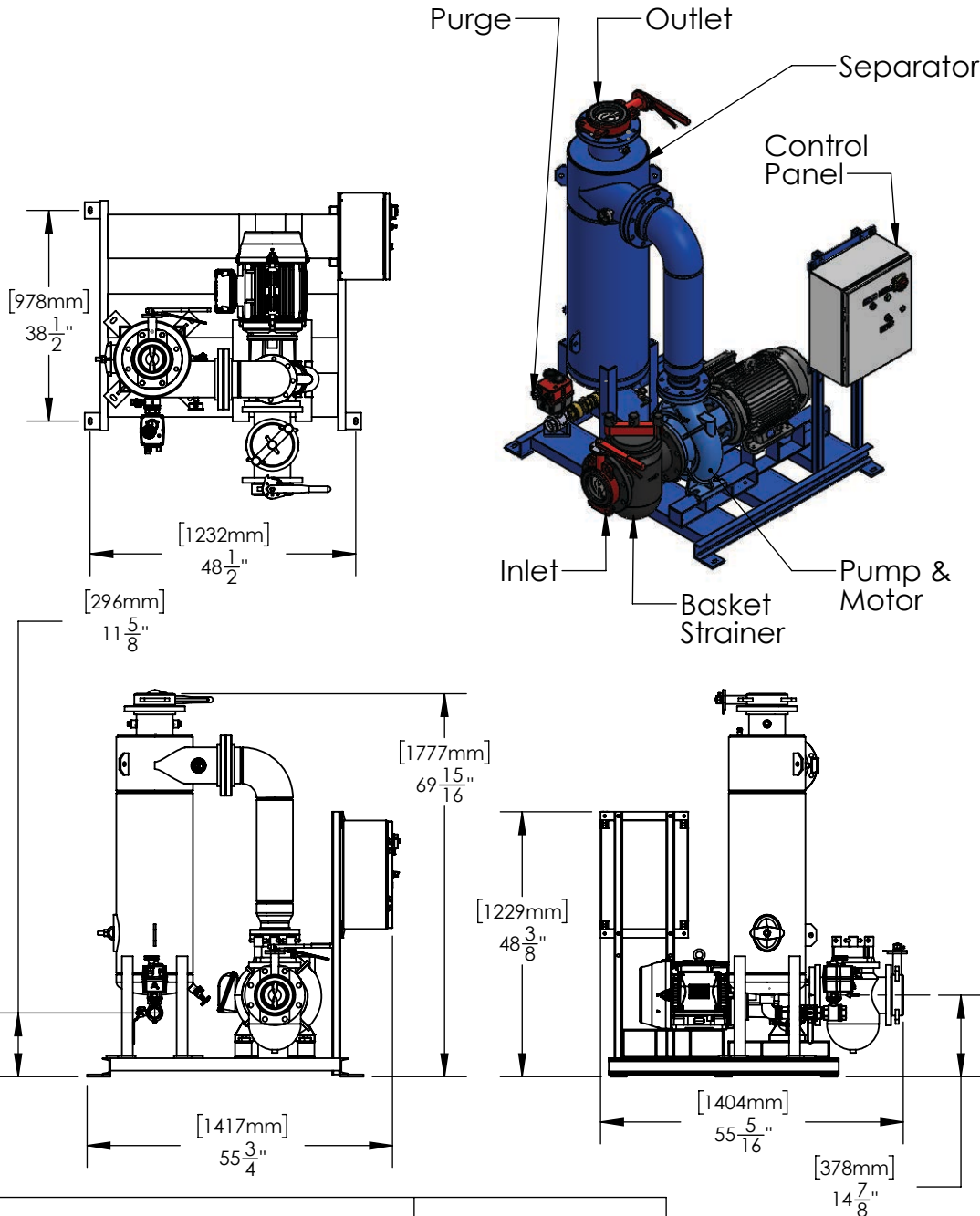

CSS600-LH

Operating Point	825 GPM(US) @ 40' TDH		
Separator - Size & Style	CS-6T-FLG, Carbon Steel, Powder Coated		
Frame Construction	Carbon Steel (Welded), Powder Coated		
Pipe Assy - Construction	Carbon Steel (Welded), Powder Coated		

ELECTRICAL - Motor & System

Horsepower (HP)	15		
Power - Volts / Hz	460/60	575/60	230/60
RPM	1750	1750	1750
Motor Amperage	21	17	42
System Total Amperage	23	19	44

PUMP

Installation	Flooded Suction Required
Case Material	Cast Iron
Impeller Material	Cast Iron
Mechanical Seal	Buna - Carbon / Ceramic

BASKET STRAINER (Optional)

Body Construction	Cast Iron
Strainer Mesh	Stainless Steel with 1/4" perforations
Connection - Type & Size	6" FLG (150#)

CONTROL PANEL (UL Listed & Labeled. Manufactured to UL 508A)

Enclosure (UL listed & CSA approved)	NEMA 4 (STD) - Carbon Steel, Powder Coated NEMA 4X (Optional) - 304
Electrical Components (UL listed & CSA approved)	Thermal Overload Starter, HOA, XFMR, "RUN" Light, Door Disconnect, Contactor, Purge Timer

PROCESS INLET

Connection - Type & Size	5" FLG (150#) - Butterfly Valve
--------------------------	---------------------------------

PROCESS OUTLET

Connection - Type & Size	6" FLG (150#) - Butterfly Valve
--------------------------	---------------------------------

PURGE - MBV (Motorized Ball Valve)

Actuator Motor	24-240V AC/DC
Connection Type	Female NPT 1.5"

PRESSURE - Maximum Operating

Pump Inlet	100 psi (6.9 bar)
Vessel	150 psi (10.3 bar)

TEMPERATURE - Maximum Operating

System	34°F - 122°F (1°C - 50°C)
--------	---------------------------

WEIGHTS

	DRY	SHIPPING	OPERATING
lbs (kg)	1262 (572)	1450 (658)	1617 (733)

*UNLESS OTHERWISE SPECIFIED - ALL DIMENSIONS ARE IN INCHES

PREPARED BY: JASON WU

PAGE: 1

RELEASED BY: BOB KAZANJY

DATE: 1/2/2019

REV: A



General Water Systems | P. O. Box 444 | Desert Hot Spring | CA | 92204
www.gwslp.com | info@gwslp.com | 951.213.9506 | 386.255.3909

CSS600-LH