

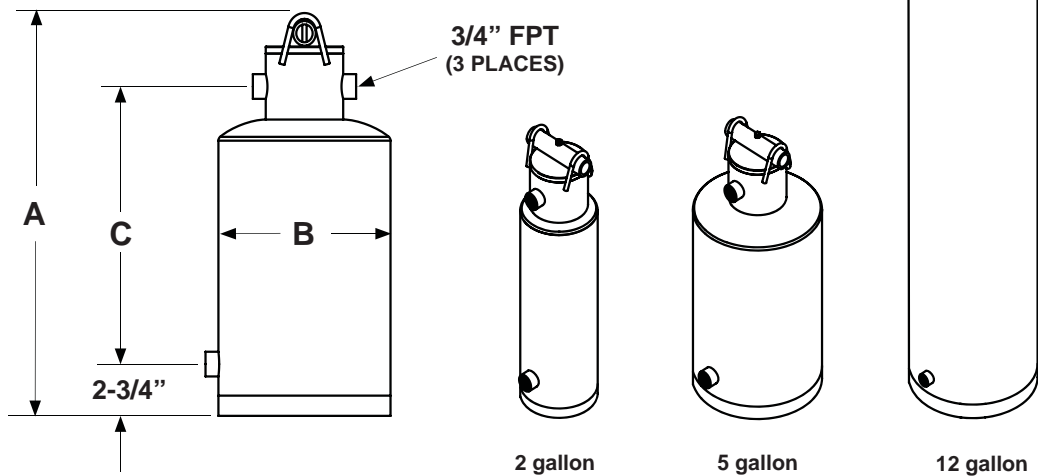

CHEMICAL BYPASS FEEDER SPECIFICATION SHEET FB-SB SERIES

- Flat Bottom vessel for floor or pedestal mounting
- Safety bar closure
- Carbon steel vessel with external powder coat
- Three standard sizes: 2, 5 and 12 gallon
- Three 3/4" FPT connections
- Optional materials: 304 or 316 stainless steel
- Accessories:
 - Pedestal Mounting
 - Funnel Package 10" x 10" or Funnel only
 - Valve Package
 - Strainer Basket (stainless steel)
 - Bag Filters (25 micron for use with Strainer Basket)
 - Cartridge Filter Assembly
 - Cartridge Filters (25 micron; 100F, 170F or 250F)



OPERATING LIMITS: 180 PSI @ 250°F, Option 380 PSI

| MODEL | CAPACITY gal (L) | ACCESS/ CONNECTIONS | DRY WEIGHT Pounds | DIMENSIONS inches (cm) | | |
|----------------|---------------------|---------------------------------|----------------------|---------------------------|-----------|---------------|
| | | | | "A" | "B" | "C" |
| FB-2-SB-CS-Z* | 2 (7.8) | 4" IPS FILLER 3/4" FPT PORTS | 18 | 22-1/8 (56.2) | 6 (15.2) | 14-7/8 (37.8) |
| FB-5-SB-CS-Z* | 5 (18.9) | | 35 | 21-1/2 (54.6) | 10 (25.4) | 14-1/4 (36.2) |
| FB-12-SB-CS-Z* | 12 (45.4) | | 61 | 45-1/8 (114.6) | 10 (25.4) | 38 (96.5) |

- CS ; Replace with -304 or -316 for stainless steel material options, add 380 to end of part number for 380 psi

CHEMICAL BYPASS FEEDER SPECIFICATION SHEET DB-SB SERIES

- Domed Bottom vessel
- Heavy-duty leg mounting with bottom drain port
- Safety bar closure
- Carbon steel vessel with external powder coat
- Three standard sizes: 2, 5 and 12 gallon
- Four 3/4" FPT connections
- Optional materials: 304 or 316 stainless steel
- Accessories:
 - Funnel Package 10" x 10" or Funnel only
 - Valve Package
 - Strainer Basket (stainless steel)
 - Bag Filters (25 micron for use with Strainer Basket)
 - Cartridge Filter Assembly
 - Cartridge Filters (25 micron; 100F, 170F or 250F)

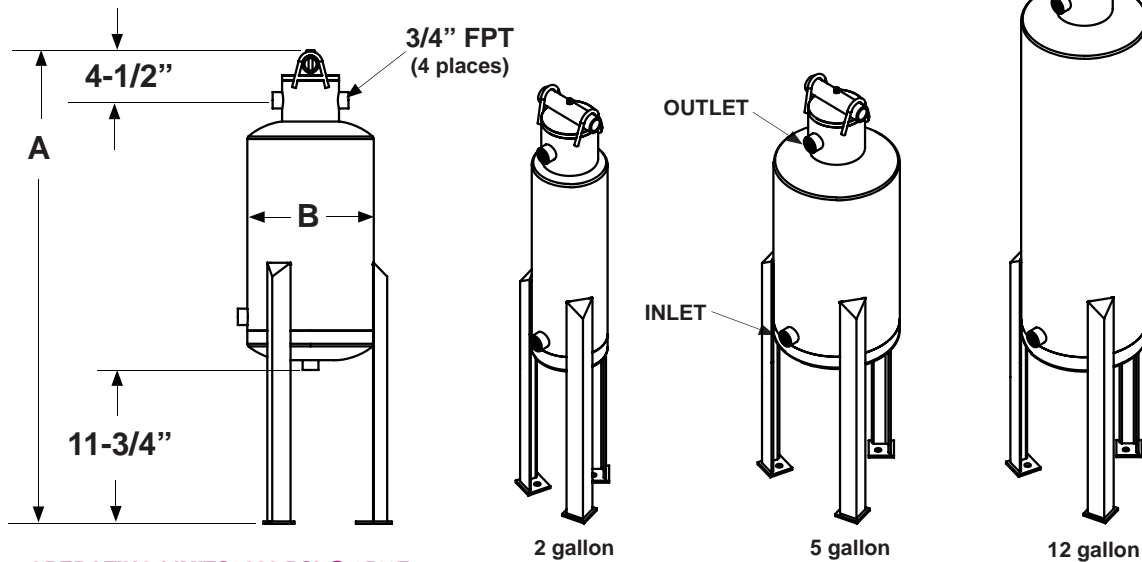

OPERATING LIMITS: 380 PSI @ 250°F

| MODEL | CAPACITY gal (L) | ACCESS/ CONNECTIONS | DRY WEIGHT Pounds | DIMENSIONS inches (cm) | |
|---------------|---------------------|---------------------------------|----------------------|---------------------------|-----------|
| | | | | "A" | "B" |
| DB-2-SB-CS-Z | 2 (7.8) | 4" IPS FILLER 3/4" FPT PORTS | 27 | 36-1/8 (91.8) | 6 (15.2) |
| DB-5-SB-CS-Z | 5 (18.9) | | 41 | 36-1/2 (92.7) | 10 (25.4) |
| DB-12-SB-CS-Z | 12 (45.4) | | 61 | 58-1/4 (148.0) | 10 (25.4) |

- CS ; Replace with -304 or -316 for stainless steel material options

CHEMICAL BYPASS FEEDER SPECIFICATION SHEET DB-GE SERIES

- Domed Bottom vessel
- Heavy-duty leg mounting with bottom drain port
- Groove End Cap Closure
- Carbon steel vessel with external powder coat
- Three standard sizes: 2, 5 and 12 gallon
- Four 3/4" FPT connections
- ASME Code Stamp Available
- Optional materials: 304 or 316 stainless steel
- Accessories:
 - Funnel Package 10" x 10" or Funnel only
 - Valve Package
 - Strainer Basket (stainless steel)
 - Bag Filters (25 micron for use with Strainer Basket)

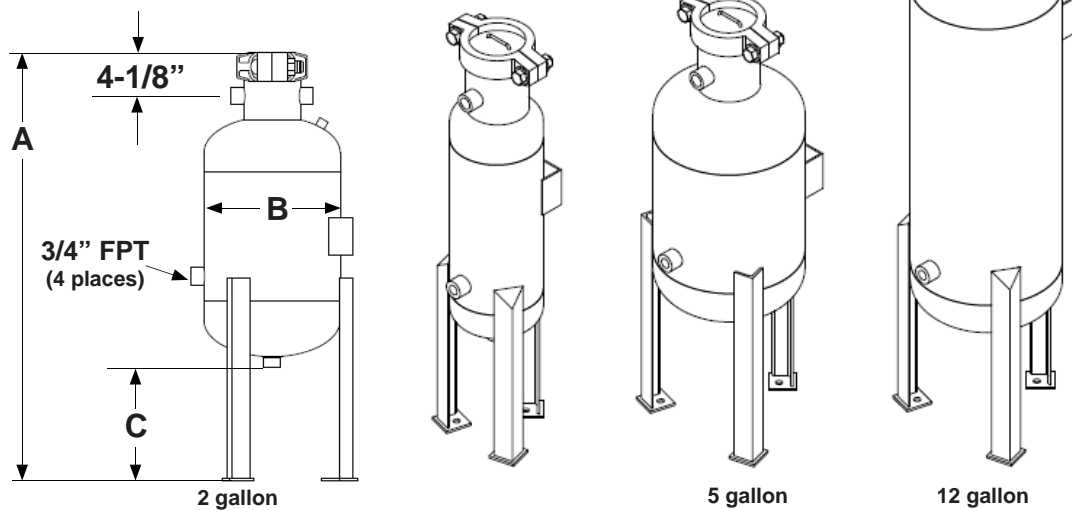

OPERATING LIMITS: 450 PSI (ASME Vessel 600 psi), 250 °F

| MODEL | CAPACITY gal (L) | ACCESS/ CONNECTIONS | DRY WEIGHT Pounds) | DIMENSIONS inches (cm) | | |
|-----------------|---------------------|---------------------------------|-----------------------|---------------------------|---------------|--------------|
| | | | | "A" | "B" | "C" |
| DB-2-GE-CS-Z-* | 2 (7.8) | 4" IPS FILLER 3/4" FPT PORTS | 55 | 34 (86.4) | 6-3/4 (17.1) | 8 (20.3) |
| DB-5-GE-CS-Z-* | 5 (18.9) | | 90 | 34 (86.4) | 10-3/4 (27.3) | 9 (22.9) |
| DB-12-GE-CS-Z-* | 12 (45.4) | | 170 | 51 (129.5) | 10-3/4 (27.3) | 7-7/8 (20.0) |

- CS ; Replace with -304 or -316 for stainless steel material options
- Z ; Replace with -A for ASME Stamped Vessel

