

1325
1300x2500mm

1332
1300x3200mm

1345
1300x4500mm

1360
1300x 6000mm

Top
quality
professional
solutions

Üstün kalite, profesyonel çözümler
Calidad superior, soluciones profesionales

EN

TR

ES

PRO series machines are our product group that combines fast and precise results with energy saving in your mass production processes. PRO Series, which offers economy and professionalism as a whole for developing and changing market conditions, was created by combining quality and performance in the R-D process with a cost-effective strategy taking into account your investment costs in production.

PRO serisi makineler, seri üretim işlemlerinizde hızlı ve hassas sonuçları, enerji tasarrufu ile birleştiren ürün grubumuzdur. Gelişen ve değişen piyasa koşulları için ekonomi ile profesyonelliği bir bütün halinde sunan PRO Serisi, üretim süreçlerinizde yatırım maliyetlerinizi göz önünde bulundurarak AR&GE sürecinde kalite ve performansın uygun maliyet stratejisi ile birleştirilmesiyle yaratıldı.

Las máquinas de la serie PRO son nuestro grupo de productos que combina resultados rápidos y precisos con el ahorro de energía en sus procesos de producción en masa. La serie PRO, que ofrece economía y profesionalidad en su conjunto para desarrollar y cambiar las condiciones del mercado, se creó combinando la calidad y el rendimiento en el proceso de I+D con una estrategia rentable que tiene en cuenta sus costos de inversión en producción.herramientas automáticas.

Made for high performance

*Yüksek performans için üretildi
Hecho para alto rendimiento*

EN

With its the state-of-the-art spindle motor allows you to get excellent results in your milling applications, including 3d machining.

TR

Son teknoloji spindle motor 3D işleme dahil freze uygulamalarınızda mükemmel sonuçlar almanızı sağlar.

ES

El motor de husillo de última tecnología le permite obtener excelentes resultados en sus aplicaciones de fresado que están incluidas en la operación 3D.

FLEXIBLE PRODUCTION WITH 4 AXIS CONFIGURATION

4 EKSEN KONFIGÜRASYON İLE ESNEK ÜRETİM

PRODUCCION FLEXIBLE CON LA
CONFIGURACION DE 4 EJES

EN

With 4-axis configuration, custom your processings on a single machine. Make flexible production with different aggregate options.

TR

4 eksen konfigürasyonu ile özel işlemlerinizi tek bir makinede uygulayın. Farklı aggregate seçenekleri ile esnek üretim yapın.

ES

Con configuración de 4 ejes, personalice sus procesamientos en una sola máquina. Haga una producción flexible con diferentes opciones de agregados.

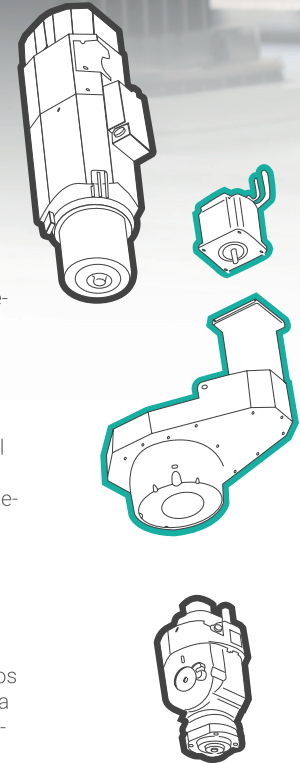

Maximum Productivity

Maksimum üretkenlik
Máxima productividad

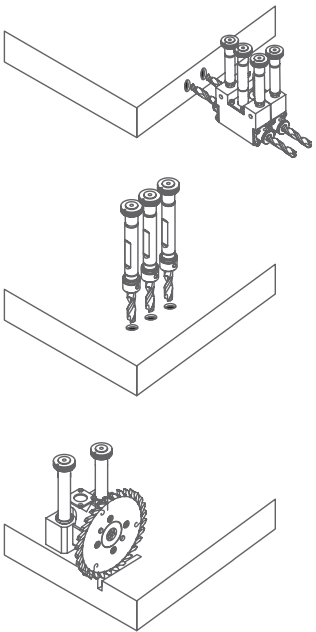

BORING UNIT

ÇOKLU DELİK ÜNİTESİ

UNIDAD DE ORIFICIOS MÚLTIPLES

EN

Shorten your lead time with customized drilling unit options

TR

İhtiyaçlarınıza göre şekillendirilebilen delik ünitesi seçenekleri ile üretim sürecinizi kısaltın.

ES

Acorte su proceso de producción con opciones de unidades de orificios que pueden moldearse según sus necesidades.

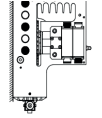
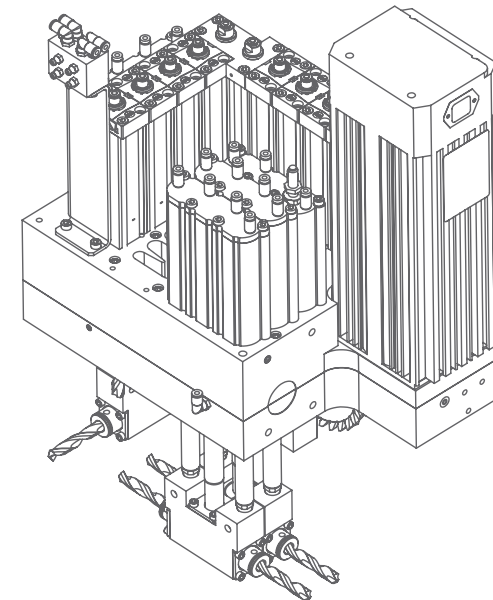

10V - 3x2H - 1 S

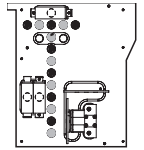

14V - 3x2H - 1 S

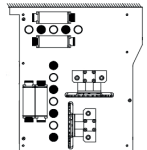

12V - 4x2H - 2 S

EXTENDED AGGREGATE USAGE AREA

AGGREGATE İLE GENİŞ
KULLANIM ALANI

UNIDAD CAMBIADOR DE
HERRAMIENTAS MOVILES

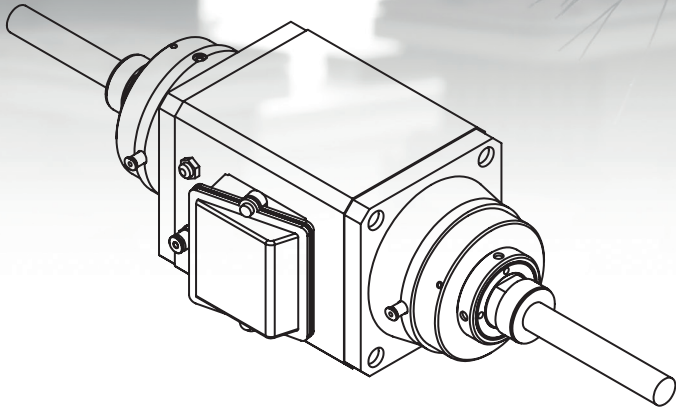
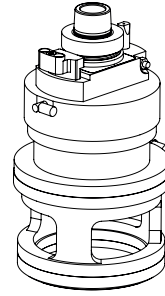
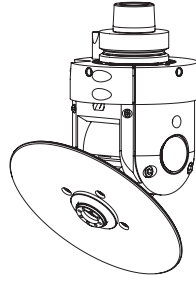
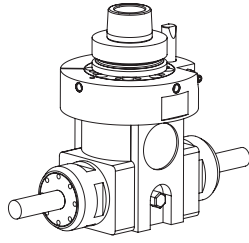

BEST CHOICE FOR DOOR PROCESSING

KAPI İŞLEMELERİNDE EN İYİ SEÇİM

LA MEJOR OPCIÓN PARA EL
PROCESAMIENTO DE PUERTAS

EN With double output side milling motor, you can process the lock and hinge holes of the door all at once

TR Çift çıkışlı yan freze motoru ile kapının kilit ve menteşe deliklerini tek seferde işleyin

ES Procesar solo de una vez los agujeros de cerradura y de bisagras de la puerta salida que se puede anadir opcionalmente

Every Second Counts

Her Saniyeniz Değerli
Cada segundo es valioso

EN

Quickly change tools with the rotary magazine to shorten machining time

TR

Hareketli takım değiş-tirme ünitesi ile kolay ve hızlı takım geçişi sağlayarak işleme sü-renizi kısaltır.

ES

Reduce el tiempo de procesado al proporcionar un cambio de herramienta fácil y rápido con su unidad de cambio de herramienta móvil.

ROTARY MAGAZINE UNIT

HAREKETLİ TAKIM DEĞİŞTİRME ÜNİTESİ

UNIDAD PARA CAMBIAR DE
EQUIPOS MOVIBLE



**CENTRAL
LUBRICATION UNIT**
Lubricates the machine at
21 different lubrication po-
ints automatically.

**MERKEZİ
YAĞLAMA ÜNİTESİ**
21 farklı bölgede otomatik
olarak yağlama sağlar.

**UNIDAD CENTRAL DE
LUBRICACIÓN**
Proporciona lubricación
automática en 21 regiones
diferentes.



**AXIS CONTROL WITH
SERVO MOTORS**
State of the art motors lo-
cated on each axis ensure
precise acceleration at high
speed

**SERVO MOTORLAR İLE
EKSEN KONTROLÜ**
Tüm eksenlerde bulunan
son teknoloji ürünü motor-
lar, yüksek hızlarda hassas
ivmelenme sağlar

**CONTROL DE EJES CON
SERVOMOTORES**
Los motores de última ge-
neración en todos los ejes
proporcionan una acelera-
ción precisa a altas veloci-
dades



**HIGH-QUALITY
RACK & RAIL**
Low-vibration, dynamic &
high-quality rails and kre-
mayer are used to provide
the best results at high
speeds.

**YÜKSEK KALİTE
KREMAYER VE RAY**
Yüksek hızlarda en iyi so-
nuc için düşük titreşim
sağlayan dinamik, yüksek
kaliteli ray ve kremayerler
kullanılmaktadır.

**CALIDAD EXCELENTE
CARRIL DE CREMAL-
ERA**

Min vibraciones bajas para
mejores resultados a altas
velocidades. Se utilizan
rieles y racks dinámicos y
de alta calidad. Estructura
corporal

LINEAR TOOL CHANGER UNIT

SABİT TAKIM DEĞİŞTİRME ÜNİTESİ

UNIDAD DE CAMBIO DE
HERRAMIENTA FIJA



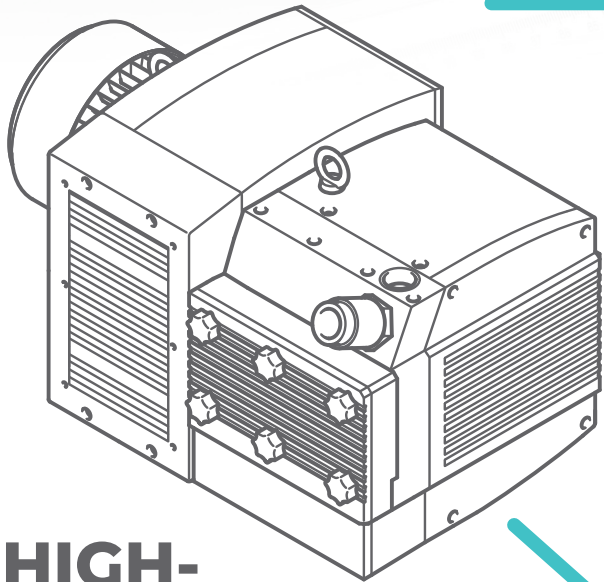
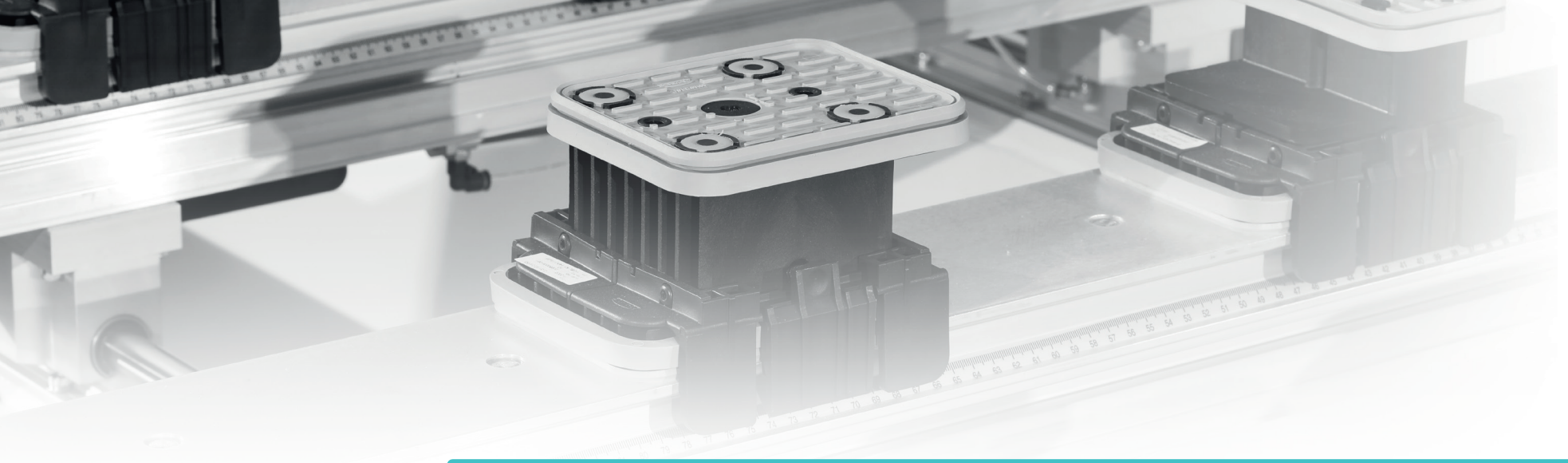

HIGH-EFFICIENCY VACUUM PUMP

GÜÇLÜ VAKUM POMPASI

BOMBA DE VACÍO DE ALTA EFICIENCIA

EN The working table comprises state of the art vacuum consoles and blocks. The discharge pistons on the consoles allow expedited discharge of work pieces.

TR Çalışma tablası son teknoloji ürünü vakum konsol ve bloklarından oluşmaktadır. Konsolda bulunan boşaltma pistonları, parçanın kolayca boşaltılmasına olanak sağlar

ES La mesa de trabajo consta de consolas y bloques de vacío de última generación. Los pistones de descarga en la consola permiten descarga fácilmente la pieza

PROFESSIONAL VACUUM EQUIPMENT

PROFESYONEL VAKUM EKİPMANLARI

EQUIPOS DE VACÍO PROFESIONAL



EN High performance efficient vacuum pump ensures firm grip on work pieces to be cut. It will support your operations for many years with its problem free construction and low maintenance costs.

TR Yüksek performanslı ve verimli vakum pompası, kesim yapılacak parçalar için maksimum tutuş sağlar. Düşük bakım maliyeti ve sorunsuz çalışan yapısı ile uzun yıllar çalışmaya imkan verir.

ES La bomba de vacío de alto rendimiento y eficiencia proporciona el máximo agarre para las piezas a cortar. Permite trabajar por muchos años con su bajo costo de mantenimiento y estructura sin problemas.

MAXIMUM SAFETY

MAKSİMUM GÜVENLİK

MÁXIMA SEGURIDAD

EN The safety options of VEGA PRO, were designed to prevent unauthorized access to the work area with a view to maximizing safety of life. These safety options which are designed in compliance with the CE norms will minimize the risk of occupational accidents in your manufacturing processes.

TR VEGA PRO 'nun güvenlik opsiyonları çalışma alanına yetkisiz girişleri engelleyerek maksimum can güvenliği sağlamak için tasarlanmıştır. CE normlarına uygun şekilde hazırlanan güvenlik opsiyonları ile imalat süreçlerinizde iş kazası risklerini minimize eder.

ES Las opciones de seguridad de VEGA PRO están diseñadas para brindar la máxima seguridad humana al evitar el acceso no autorizado a la zona de trabajo. Minimiza los riesgos de accidentes laborales en sus procesos de fabricación con opciones de seguridad preparadas de acuerdo con normativa CE.

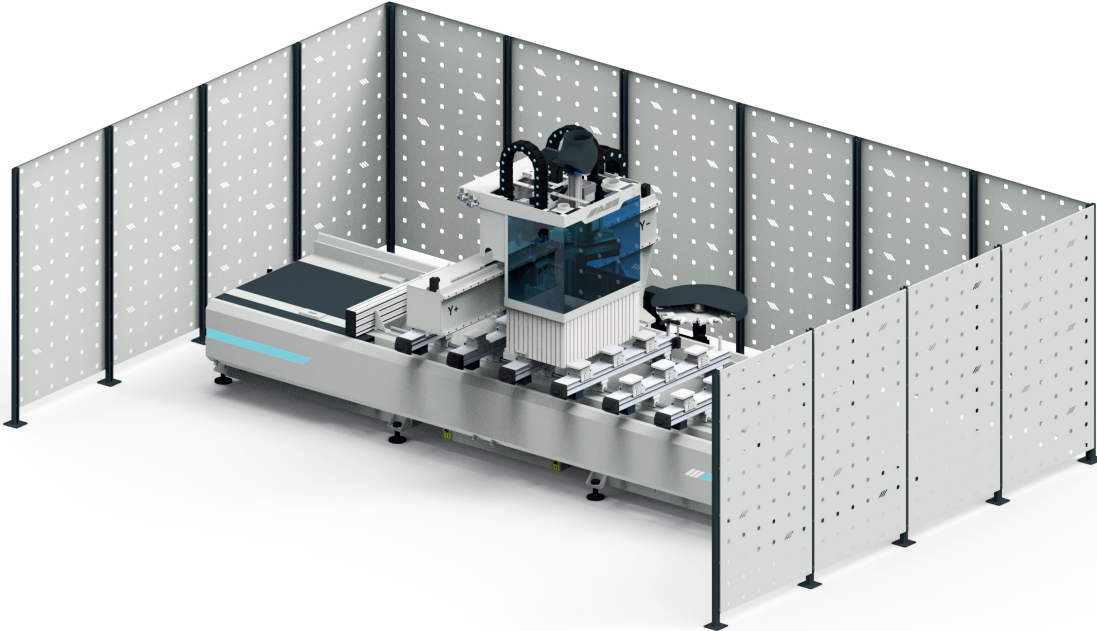

Safety Mat

Güvenlik Paspası

Estera de Seguridad

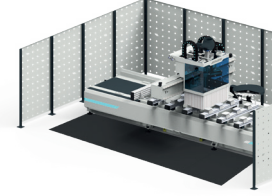

Light Barrier

Işık Bariyeri

Barrera de Luz

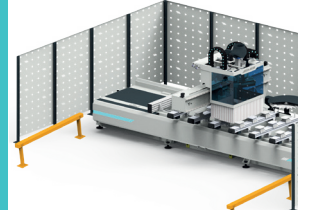

Safety Fence

Güvenlik Çiti

Valla de Seguridad

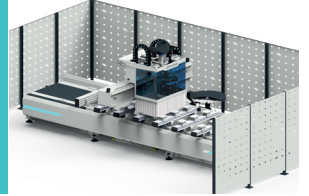



NEXT GENERATION CNC CONTROL UNIT

YENİ JENERASYON CNC KONTROL ÜNİTESİ

UNIDAD DE CONTROL CNC DE ÚLTIMA GENERACIÓN

EN

The next generation control unit is powered by a PC designed for industrial operations. It allows you to make your transactions quickly and easily without getting stuck.

TR

Endüstriyel işler için üretilen PC'den gücünü alan yeni jenerasyon kontrol ünitesi. İşlemlerinizi takılmadan, hızlı ve kolay gerçekleştirmenizi sağlar.

ES

Unidad de control de nueva generación alimentada por PC fabricada para trabajos industriales. Le permite realizar sus transacciones de forma rápida y sencilla sin quedarse atascado.

EASY TO USE INTERFACE

KULLANIMI KOLAY ARAYÜZ

INTERFAZ FÁCIL DE USO



USER EXPERIENCE / KULLANICI DENEYİMİ / EXPERIENCIA DE USUARIO



"As easy to use as a mobile phone"

"Telefon kullanmak kadar kolay."

"Tan fácil como usar un teléfono"

"The machine helps us to perform machining operations accurately by guiding us with warning messages."

"Uyarılar bizi yönlendirerek, doğru işlem yapmamıza destek oluyor."

"Las alertas nos orientan y nos ayudan a realizar la acción correcta."

Our aftersales support team is always there for you when you need them thanks to the remote control feature of VEGA PRO.

VEGA PRO'nun uzaktan kontrol özelliği ile, ihtiyaç duyduğunuz her an satış sonrası destek ekibimiz yanınızda

Gracias a la función de control remoto de VEGA PRO, nuestro equipo de soporte posventa le apoya siempre que lo necesite.



7

LANGUAGE 7 DİL SEÇENEĞİ OPCIONES DE 7 IDIOMAS

TR / EN / AR / RU / ES / FR / NL

Controlling Unit & Safety Options
Kontrol Ünitesi & Güvenlik Opsiyonları
Unidad De Control Y Opciones De Seguridad

AW

AES WOP

Design freely

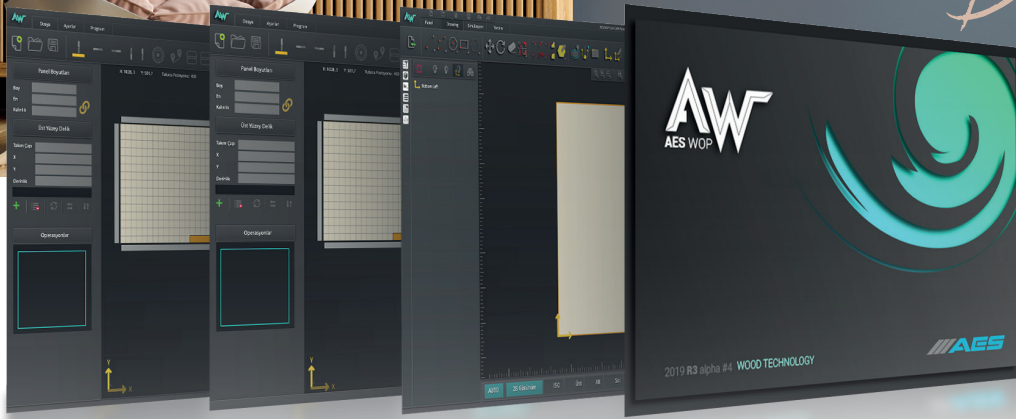

PARAMETRIC LIBRARY

PARAMETRIC KÜTÜPHANE

BIBLIOTECA PARAMETRICA

- EN** Change your designs with one click with the parametric module. Save ready-made modules in your library and reuse. Complete the most difficult and complex drawings in minutes with its advanced parametric structure.
- TR** Parametrik modül ile tasarımlarınızı tek tıklama ile değiştirin. Hazır modülleri kütüphanenize kayıt edin ve tekrar kullanın. Gelişmiş parametrik yapısı ile en zor ve karmaşık çizimleri dakikalar içerisinde tamamlayın.
- ES** Cambia tus diseños con un clic con el módulo paramétrico. Guarde los módulos listos para usar en su biblioteca y reutilícelos según sea necesario. Complete los dibujos más difíciles y complejos en minutos con su estructura paramétrica avanzada.

MACHINE AND PARTS SIMULATION

MAKİNE VE PARÇA SİMÜLASYONU

BIBLIOTECA PARAMETRICA

- EN** With the machine and part simulation feature, check your designs before producing and minimize production errors.
- TR** Makine ve parça simülasyon özelliği ile tasarımlarınızı üretmeden önce kontrol edin ve üretim hatalarını minimuma indirin.
- ES** Con la función de simulación de piezas y máquinas, verifique sus diseños antes de producir y minimice los errores de producción.

SIMPLY CREATE SMART DESIGNS

BASİTÇE, AKILLI TASARIMLAR OLUŞTURUN

SIMPLEMENTE, CREE DISEÑOS INTELIGENTES

EN With its parametric design feature, AES WOP CAD/CAM program has been prepared to meet all your design needs. Its easy-to-use interface and advanced features allow you to prepare flexible and fully functional designs.

TR Parametrik tasarım özelliği ile AES WOP CAD/CAM programı tüm tasarım ihtiyaçlarınızı karşılayacak şekilde hazırlanmıştır. Kullanımı kolay arayüzü ve gelişmiş özellikleri, esnek ve tam işlevsel tasarımlar hazırlamanızı sağlar.

ES Con su función de diseño paramétrico, el programa CAD/CAM AES WOP ha sido preparado para satisfacer todas sus necesidades de diseño. Su interfaz fácil de usar y sus funciones avanzadas le permiten preparar diseños flexibles y completamente funcionales.



DESIGN
TASARLA
DISEÑO



TRANSFER
TRANSFER ET
TRANSFERIR

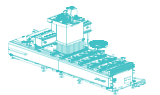

PRODUCE
ÜRET
PRODUCCIÓN

| CUTTING HEAD KESİM YÜKSEKLİĞİ ALTO DE CORTE | | VEGA PRO | | |
|---|-----------|-----------|------------|------------|
| | | A | B | C |
| STD. | mm / inch | 50 / 1.96 | 140 / 5.51 | 170 / 6.69 |
| OPT. | mm / inch | 85 / 3.34 | 110 / 4.33 | 170 / 6.69 |

| TECHNICAL INFORMATION TEKNİK ÖZELLİKLER ESPECIFICACIONES TECNICAS | VEGA PRO | | | |
|---|-------------------------------------|----------------------------|---------------------------------|----------------------------|
| | 1325 | 1332 | 1345 | 1360 |
| Working Area Dimensions Çalışma Alanı Ölçüleri Mediciones del Area de Trabajo | 1.300x2.500 mm 51"x98" | 1.300x3.200 mm 51"x126" | 1.300x4.500 mm 51"x177" | 1.300x6.000 mm 51"x236" |
| Z Axis Distance Z Eksen Ölçüleri Z-As Abstand | 200 mm 7,8" | | | |
| Magazin Unit Magazin Ünitesi Unidad De Herramientas | Rotary Magazine (8 Pcs) | | | |
| Spindle Motor Power Spindle Motor Gücü Spilmotorvermogen | 9 kW HSK F63 12 HP HSK F63 | | | |
| Side Milling Motor Yan Freze Motoru Motor De Fresado Lateral | 5,5 kW-ER32(Evo Series) 8HP-ER32 | | | |
| Boring Unit Çoklu Delik Ünitesi Unidad de Herramientas | 10 V - 3x2 H - 1 S | | | |
| CAD/CAM Program CAD/CAM Progam Programa CAD/CAM | AES WOP | | | |
| Number of Vacuum Console Vakum Konsol Sayısı Unidad de Consola | 4 Pcs | 6 Pcs | 8 Pcs | 10 Pcs |
| Axis Speeds Eksen Hızları Las velocidades del eje | 70-70-20m/min 2755-2755-787 IPM | | | |
| Vacuum Pump Power Vakum Pompası Gücü Potencia de la bomba de vacio | 100 m ³ /h 4,8 HP | | 140 m ³ /h 5,4 HP | |

TECHNICAL INFORMATION

TEKNİK ÖZELLİKLER

ESPECIFICACIONES TÉCNICAS

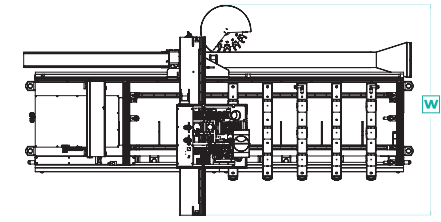
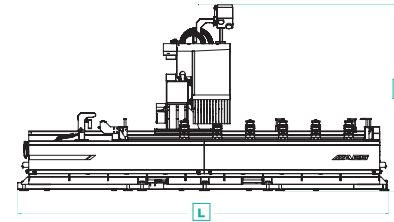

| DIMENSIONS ÖLÇÜLER DIMENSIONES | | L | W | H |
|--------------------------------------|-----------|---------------|-----------|---------------|
| | | VEGA PRO 1325 | mm / inch | 4700 / 185.00 |
| VEGA PRO 1332 | mm / inch | 5400 / 212.6 | | |
| VEGA PRO 1345 | mm / inch | 6700 / 263.8 | | |
| VEGA PRO 1360 | mm / inch | 8200 / 322.8 | | |

* The technical specifications and drawings provided in the catalogue are non-binding. Stock images and drawings may contain optional equipment. AES Group reserves the right to make amendments without notice.

* Katalogda bulunan teknik özellikler ve çizimler bağlayıcı değildir. Bazı fotoğraflar ve çizimler opsiyonel ekipmanları içerebilir. AES Group bilgilendirme yapmaksızın değişiklik yapma hakkını saklı tutmaktadır.

* Las especificaciones técnicas y dibujos del catálogo no son vinculantes. Algunas fotos y dibujos pueden incluir equipamientos opcionales. Grupo AES se reserva el derecho de realizar cambios sin previo aviso.

ALWAYS WITH YOU

DAİMA YANINIZDA

SIEMPRE CON USTED

EN

Our expert after-sales service staff is 24/7 at your service for all your needs. For your permanent satisfaction, it provides an accurate diagnosis and intervention to all your problems as soon as possible with both instant remote connection support and on-site service. AES GROUP protects your investments with after-sales services for uninterrupted production.



REMOTE AND ON-SITE SERVICE SERVICES

UZAKTAN VE YERİNDE SERVİS HİZMETLERİ

SERVICIOS DE MANDO A DISTANCIA Y LUGAR

TR

Uzman satış sonrası hizmet kadromuz, tüm ihtiyaçlarınız için 7 gün 24 saat hizmetinizdedir. Daimi memnuniyetiniz için, gerek anlık uzak bağlantı desteği ile gerekse yerinde servis hizmeti ile en kısa sürede, tüm sorunlarınıza doğru teşhis sağlayarak müdahale sağlamaktadır. AES GROUP, kesintisiz üretim yapmanız için sunduğu satış sonrası hizmetler ile yatırımlarınızı korur.



TRAINING AND INSTALLATION SERVICES

EĞİTİM VE KURULUM HİZMETLERİ

SERVICIOS DE FORMACIÓN E INSTALACIÓN

ES

Nuestro experto personal de servicio posventa está a su servicio las 24 horas del día, los 7 días de la semana para todas sus necesidades. Para su satisfacción permanente, brinda un diagnóstico preciso e intervención a todos sus problemas a la mayor brevedad posible con soporte instantáneo de conexión remota y servicio en el sitio. GRUPO AES protege sus inversiones con servicios posventa para una producción ininterrumpida.



SPARE PARTS AND SALES SUPPORT

YEDEK PARÇA VE SATIŞ DESTEĞİ

PIEZAS DE RECAMBIO Y SOPORTE DE VENTA



UNINTERRUPTED CONNECTION WITH WEB PLATFORM

WEB PLATFORMU İLE KESİNTİSİZ BAĞLANTI

CONEXIÓN PERMANENTE CON LAS PLATAFORMA WEB



24/7 0850 22 77 AES
CALL CENTER
CENTRO DE LLAMADAS

CNC MACHINING CENTER (FLAT TABLE GROUP)
CNC İŞLEME MERKEZİ (DÜZ TABLA GRUBU)
CENTRO DE PROCESAMIENTO CNC (GRUPO DE PLATAFORMA PLANA)

ULTRA
SERIES U



▪ RAPTOR ULTRA



▪ EXTREME ULTRA

PRO
SERIES P

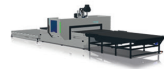

▪ SUPER NOVA



▪ FLEXA PRO

CNC MACHINING CENTER (CONSOLE TABLE GROUP)
CNC İŞLEME MERKEZİ (KONSOL TABLA GRUBU)
CENTRO DE PROCESAMIENTO CNC (GRUPO DE PLATAFORMA DE CONSOLAS)

ULTRA
SERIES U



▪ VEGA 5X



▪ VEGA ULTRA

PRO
SERIES P



▪ VEGA 5X PRO



▪ VEGA PRO

CNC DRILLING MACHINES
CNC DELİK MAKİNELERİ
MÁQUINAS DE AGUJERO CNC

ULTRA
SERIES U

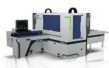

▪ GO! ULTRA

PRO
SERIES P



▪ GO! 1300
▪ GO! 1300 M/S
▪ GO! 1300 M/S ATC



▪ SIRIUS 950
▪ SIRIUS 950 M/S
▪ SIRIUS 950 M/S ATC

BEAM SAW MACHINES
PANEL EBATLAMA MAKİNELERİ
SECCIONADORAS

ULTRA
SERIES U



▪ ALPHA PS 05
▪ ALPHA PS 06



▪ ALPHA PS 03
▪ ALPHA PS 04

PRO
SERIES P



▪ BETA PS 03
▪ BETA PS 04

EDGE BANDING MACHINES
KENAR BANTLAMA MAKİNELERİ
CANTEODORAS MONOLATERALES AUTOMÁTICAS

ULTRA
SERIES U

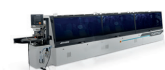

▪ GAMMA ULTRA

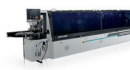

▪ GAMMA MX

PRO
SERIES P

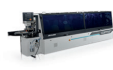

▪ PRIMA 6M
▪ PRIMA 5M

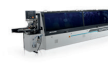

▪ GAMMA 7M
▪ GAMMA 6M

**PRODUCTS
GROUP**
ÜRÜN GRUPLARIMIZ
GRUPO DE PRODUCTOS

