

E2000 - EP66 - EM30

USER MANUAL

FOR PUMP CONTROL

*Safety instructions Installation
& operating manual*



Index for this technical manual

I.- Purpose of the manual and revision history	4
II.- Glossary and warnings.....	4
II.a.- Glossary of abbreviations used in this manual	4
II.b.- Icons for notes, important information or warnings.....	4
II.c.- Security warnings.....	4
II.d.- Recommendation for commissioning.....	4
II.d1- Return the converter to its default factory settings	5
II.d2- Motor autotuning.....	5
III.- Development of the parameter selection menu.....	6
1.- Simple pump.....	7
1.1.- Simple control mode.....	7
1.2.- Level control mode.....	8
1.3.- Pressure empty mode.....	9
1.3.a.- Change of sensor for the PID.....	10
1.4.- Well pumps mode.....	11
1.5.- Solar limitation mode.....	13
1.6.- Fire-fighting mode.....	15
1.6.a.- Jockey pump.....	16
1.6.b.- Fire-fighting pump.....	17
2.- Regulated + fixed.....	18
2.1.- Regulated + fixed WITHOUT rotation	19
2.2.- Regulated + fixed, rotation by time of use.....	20
2.3.- Regulated + fixed, rotation after falling asleep the regulated	21
3.- All regulated	22
3.a.- Connection for communications	23
3.b.- Automatic synchronization	23
3.b.1- Initial synchronization to the commissioning	24
3.b.2- Synchronization after adding a converter to the chain	25
3.b.3- Synchronized parameters	26
3.1.- Regulated fixed	27
3.2.- Multi-master rotation by time of use of the Master.....	28
3.3.- Multi-master rotation after falling asleep the Master	29
4.- Auxiliary and protection functions	30
4.1.- Protection functions	30
4.1.a.- Protection of access to the Pump Control	30
4.1.b.- Anti-jam function.....	31
4.1.c.- Leak detection	33
4.1.d.- Dry running	34
4.1.e.- Filling of the installation.....	35
4.2.- Auxiliary functions	36
4.2.a.- Water flow detection	36
4.2.b.- Cleaning of the pump	37
4.2.c.- MANUAL / AUTOMATIC control	38
4.2.d.- Anti-rust/Anti-freeze.....	40

4.2.e.- Timer.....	41
4.2.f.- Solar/well pump autotuning	43
4.2.g.- Anti-return valve control	44
4.2.h.- Flow meter	45
4.2.i.- User macros	47
4.3.- Control modes.....	48
4.3.a.- SP Adjustable by impulses of DI inputs	48
4.3.b.- Multiple SP	48
5.- Pump Control Menu: Parameter list: I / O Configuration	49
6.- Pump Control Menu: Parameter List: PID Configuration	51
7.- Pump Control Menu: Parameter list: Control regulation	55
8.- List of alarms	59
9.- Observations for optimal running	61
9.1.- The process units and PID	61
9.2.- Acceleration and deceleration	62
9.3.- Activation of auxiliary pumps (fixed or regulated)	63
9.4.- Deactivation of fixed auxiliary pumps	64
9.5.- Deactivation of regulated auxiliary pumps	65
9.6.- Automatic restart after voltage failures	66
PERSONAL NOTES:.....	67
PERSONAL NOTES:.....	68
PERSONAL NOTES:.....	69
PERSONAL NOTES:.....	70
PERSONAL NOTES:.....	71

I.- Purpose of the manual and revision history

This manual is intended for the specialist technician in pump installations, and wants to be a complementary help for the commissioning of your installation. It is assumed, to the technician, the judgment of knowing which pumping system and which functions are the most adequate for the purpose pursued in your station or pumping group.

The updates history of this manual is shown in the following table:





<i>Date</i>	<i>Version</i>	<i>Detailed description</i>	<i>Author</i>
05/04/2019	1.0	Official version for pumping system, with all the operating modes for pumps, special parameters and explanatory charts.	MPR
23/04/2019	1.1	Correction of minor errors of version 1.0	MPR

II.- Glossary and warnings

II.a.- Glossary of abbreviations used in this manual

SP	S et P oint	PV	P rocess V alue
PID	P roportional, I ntegral and D erivative control algorithm used in the regulation loop.		Indicates the text that will be displayed on the multimedia keyboard of the EP66 or EM30 converters. Any of them can be used with E2000/E2100 .
PLC	P rogrammable L ogic C ontroller	RTC	R eal T ime C lock

II.b.- Icons for notes, important information or warnings

	Return to the index. This manual is specially designed <u>thinking about its electronic use</u> , from a tablet or a PC . This help, located at the bottom of the page, offers the possibility of always returning to the index of this manual.
	Information, note of important information to take into account. It does not necessarily generate malfunctions, it does not entail significant risk.
	Important information to respect. Malfunctions can occur that not involve significant risks.
	Warning to respect. Situations that generates breaks or damages and/or carry significant risks can occur.

II.c.- Security warnings

This manual does not describe or insert any safety warning for the connection or electrical environment. All of them correspond to the installation and commissioning of the converters or the pumps, and they are perfectly detailed in the corresponding manual.

II.d.- Recommendation for commissioning

It is recommended to initially return the device to its default factory values and to match the converter with its motor by performing the appropriate autotuning, before any parameterization procedure and especially if you have doubts that the converter has been previously programmed for other tasks. Both procedures are described below

II.d1- Return the converter to its default factory settings

If you want to recover the default factory values of the converter, use this parameter:

Param.	Display / Use	Options/Range	Def.
F160	 : Default RESET Reverting to manufacturer values	0 : Normal Operation 1 : Factory Parameters	0

Procedure for resetting factory parameters:

Select parameter **F160**, press [SET], the original parameter **F160** value is 0, press the key  to set **F160=1** press [SET] again.

After a few seconds all the factory default parameters are restored.





The value in **F160** return to 0, after the restoration process has been completed.

	ATTENTION: The process will not restore the default factory values in the following parameters: F400, F402, F406, F408, F412, F414, F421, F607, F732, F742, F745, F901
---	--

II.d2- Motor autotuning

If you want to carry out the motor autotuning, follow these steps carefully.

Set the parameters **F801** to **F810** with the values of **THE MOTOR PLATE**.

Param.	Display / Use	Options/Range	Def.
F801	 : Motor rated power Rated power on the motor plate (kW)	0.2 ~ 1000 kW	0
F802	 : Motor rated voltage Rated voltage on the motor plate (V)	1 ~ 440 V	
F803	 : Motor rated current Rated current on the motor plate (A)	0.1 ~ 6500 A	
F805	 : Motor rated rpm Rated speed on the motor plate (RPM)	1 ~ 30000 U/min	1500 RPM
F810	 : Motor rated frequency Rated motor frequency (Hz)	1.0 ~ 300.0 Hz	50,00 Hz

When you have adjusted all the previous parameters, change this parameter:

Param.	Display / Use	Options/Range	Def.
F800	 : AUTOTUNING Mode Selection measured from motor data (AUTOTUNING)	0 : AUTOTUNING deactivated 1 : START AUTOTUNING dynamic 2 : START AUTOTUNING static	0

Set **F800=1**, if the motor can turn when doing the autotuning or **F800=2** if it is coupled to the machine and it can not turn.

After saving the value, press [RUN] on the keyboard.

For a few seconds the display will show **TEST** and at the end the autotuning **F800** will return to 0 and **TEST** will disappear from the display.

The converter is parameterized with the values of the connected motor. (You can redo the autotuning whenever you want)

III.- Development of the parameter selection menu

The structure of the pumping menu follows the following flow diagram.

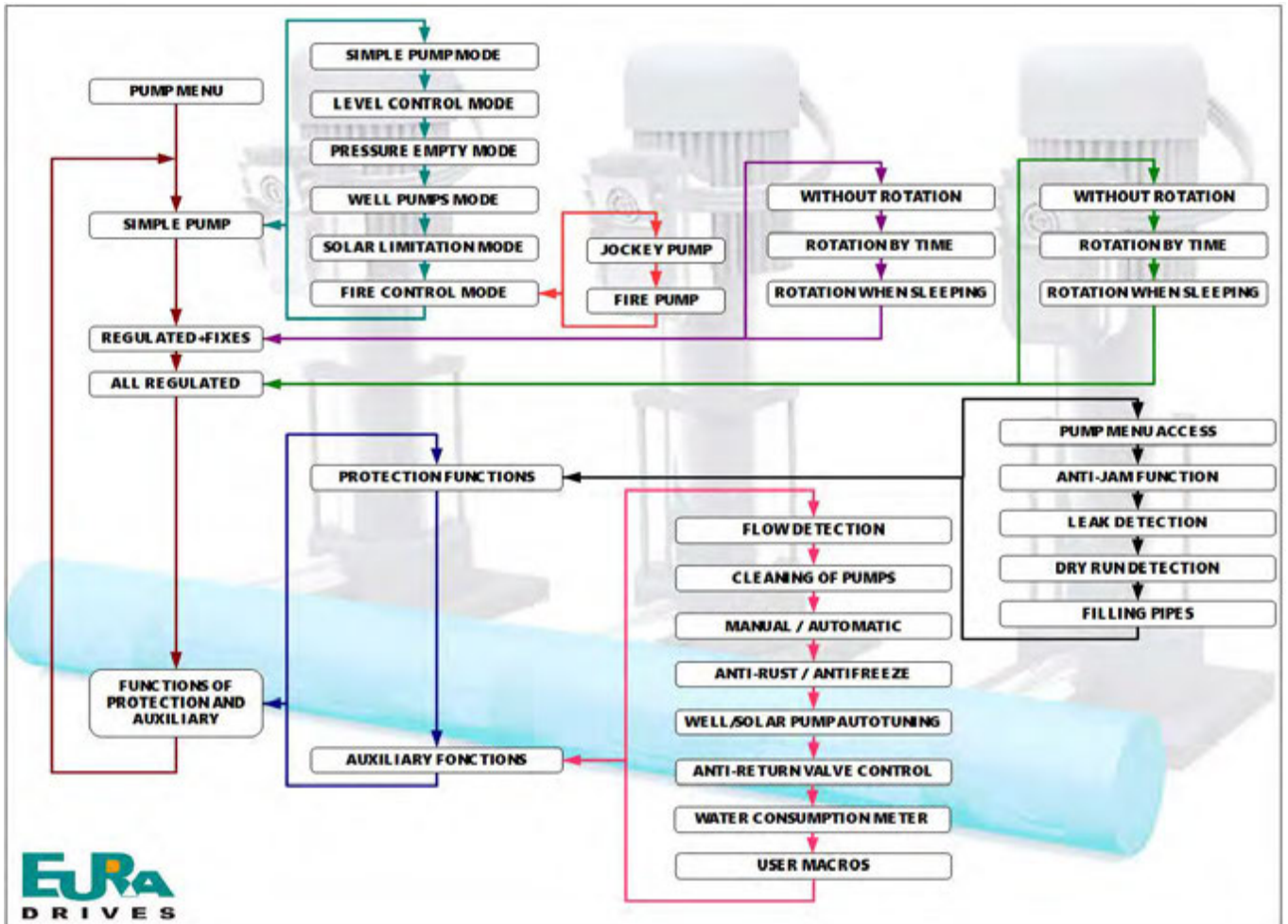

The description of the functions developed in this menu are detailed below in the different sections of this manual.

	<p>ATTENTION:</p> <p>Although in principle the program is the same for all converter series EURA DRIVES, there is peculiarities that stand out from one series on the other. These particularities are specifically indicated in each paragraph.</p>
---	--

1.- Simple pump

The pumping control mode for a simple pump is the most commonly used in well extraction systems, simple irrigation systems, transfer between tanks, filling or emptying tanks, extraction or solar irrigation, fire fighting systems, etc...that only need to exercise the control over a pump driven by a converter.

The control over the speed of the pump can be the result of the **PID** function or of the regulation by the arrows of the keyboard or a external potentiometer.

The control modes are detailed below.

1.1.- Simple control mode

For a pump with simple operation, without any special function in addition to the “Fall asleep” and “Wake up” function, **PV** by analog sensor mA or V.

- Configure parameters in [5.- Pump Control Menu: Parameter list: I / O Configuration](#) that proceed according to the work mode.
- Configure parameters of the **PID** in [6.- Pump Control Menu: Parameter List: PID Configuration](#) that proceed according to the work mode, having special relevance those that are detailed below.

<i>Param.</i>	<i>Display / Use</i>	<i>Options/Range</i>	<i>Def.</i>
FA00	 : PID Controller mode Controller configuration	0 : Simple pumping control	0

- Configure parameters of the regulation control in [7.- Pump Control Menu: Parameter list: Control regulation](#) that proceed according to the work mode, having special relevance those that are detailed below.

<i>Param.</i>	<i>Display / Use</i>	<i>Options/Range</i>	<i>Def.</i>
F203	 : Primary setpoint X Possible reference input ways of the first speed "X"	9 : PID control	0

1.2.- Level control mode

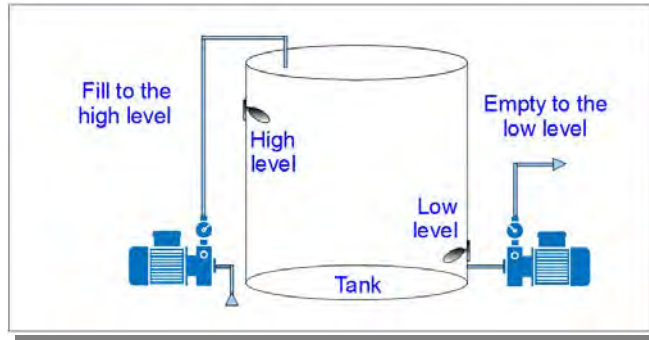

For a pump that does not use pressure sensor, but level sensor (minimum or maximum) as the only limitation of operator.







- Configure parameters in [5.- Pump Control Menu: Parameter list: I / O Configuration](#), paying special attention to the particular parameters for this mode that are indicated below:

Param.	Display / Use	Options/Range	Def.
F316 ~ F321 (F323)	 : Dlx func. assignment Configure Dlx for the desired states	71 : Filling 72 : Emptying 73 : HIGH entry level 74 : LOW entry level	See paragr. 5

- Configure parameters in [7.- Pump Control Menu: Parameter list: Control regulation](#)
The particular parameters for this mode are indicated below:

Param.	Display / Use	Options/Range	Def.
FA96	 : Level Control Activation of the mode: Level control	0 : Disabled 1 : Enabled	0
F203	 : Primary setpoint X Possible reference input ways of the first speed "X"	0 : Internal reference (F113) with memory	0

	Define F203 =0, to fill/empty a tank at a certain speed (50Hz by default). The speed is adjusted using the keys  or  on the keyboard (or in F113 parameter) and it stays saved even if the converter is turned off. If you want, you can also regulate the speed by using the keyboard or an external potentiometer.
	The parameters of 6.- Pump Control Menu: Parameter List: PID Configuration will not be required. However, if they have been programmed previously, for other functions, they may interfere with the level control, for example to define the speed of the pump. It is recommended to reset the default factory values (F160 =1) before adjusting this control mode.

1.3.- Pressure empty mode

The layout of the installation is as shown in the image below.

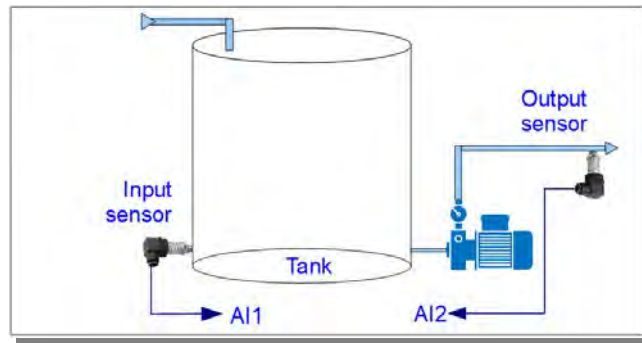

To use this working mode, two sensors must be used.

The input sensor (in *AI1*) measures tank pressure. The output sensor (in *AI2*) measures the pressure demanded in the installation.

If *AI1* detects that there is not enough water, the pump will stop. If there is enough water, it will allow the operation of the pump.

1) When $PV < FA52$ at the input, after the time *FA54*, there is not enough water, the pump stops and runs "EP5"

2) When $PV > FA51$ at the input, after the time *FA53*, there is enough water, the pump starts running.

The regulation of the pump will be carried out by measuring the output pressure (*AI2*)











- Configure parameters in [5.- Pump Control Menu: Parameter list: I / O Configuration](#). There are no special parameters for this mode.
- Configure parameters of the *PID* in [6.- Pump Control Menu: Parameter List: PID Configuration](#), paying special attention to the **note (b)** of this paragraph. The particular parameters of the *PID* are indicated below:

Param.	Display / Use	Options/Range	Def.
FA13	: Auxiliar.Press.Source Origin for the input pressure sensor	0 : Deactivated/ no sensor 1 : Sensor connected to <i>AI1</i> 2 : Sensor connected to <i>AI2</i>	0
FA49	: Auxiliar.Press.Range Input pressure sensor range	0,00 ~ 10,00 Bar NOTE: Bar is the default unit; it can be changed in <i>FA34</i> .	2,50 Bar
FA51	: Press. threshold IN 1 Sensor pressure threshold IN 1 (input sensor)	FA52 ~ FA49	
FA52	: Press. threshold IN 2 Sensor pressure threshold IN 2 (output sensor)	0,0 ~ FA51	
FA53	: Delay 1 Supervision time to restart the pump	0,0 ~ 60,0 seconds	0,0 sec.
FA54	: Delay 2 Supervision time to stop the pump	0,0 ~ 60,0 seconds	0,0 sec.
FA56	: Main sensor fault Activate the error control of the output sensor	0 : Deactivated 1 : Message. Error AEr0	0
FA57	: Auxiliar.Sensor fault Activate the error control of the input sensor	0 : Deactivated 1 : Message. Error AEr1	0

- Configure parameters in [7.- Pump Control Menu: Parameter list: Control regulation](#), that proceed. There are no special parameters for this mode.

1.3.a.- Change of sensor for the PID

In this pumping operation mode, it is possible to configure the change of the sensor to the one that you want to be the reference sensor for the *PID*. The parameters involved are indicated below:

Param.	Display / Use	Options/Range	Def.
FA90	 : In/Out Switchover Activation sensor change for reference <i>PV</i> of the <i>PID</i>	0 : Deactivated 1 : Activated	0
FA91	 : IN up-limit press. High pressure limit of the input sensor	FA93 ~ FA49  NOTE: Bar is the default unit; it can be changed in FA34.	2,50 Bar
FA92	 : IN switchover press. Pressure for <i>SP</i> change	FA94 ~ FA49  NOTE: Bar is the default unit; it can be changed in FA34.	0,50 Bar
FA93	 : Auxillar.Setpoint <i>SP</i> for input pressure	FA94 ~ FA91  NOTA: Bar is the default unit; it can be changed in FA34.	1,00 Bar
FA94	 : Sleep Press.Auxillar Input pressure to wake up	0 ~ FA93  NOTA: Bar is the default unit; it can be changed in FA34.	0,00 Bar
FA95	 : Auxillar.PID Polarity Polarity for <i>PID</i> control over the input sensor	0 : Positive = Direct / Pressure / Filling 1 : Negative = Inverse / Empty / Emptying	

	<p>Additional information on operation</p> <p>If FA90=1, the possibility of changing <i>PV</i> for the <i>PID</i> is activated If so: If the input sensor has $PV < FA92$, the <i>PID</i> uses the <i>PV</i> of the input sensor If the input sensor has $PV > FA93$, el <i>PID</i> uses the <i>PV</i> of the output sensor</p>
---	--

1.4.- Well pumps mode

For well pumps the following parameters are very important:

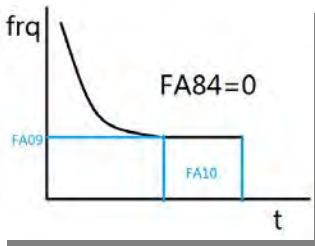

With **FA07**= 0, the "sleep" mode is enabled.

With **FA84**= 0, if the pump operates at frequency **FA09** for a period of time setting in **FA10**, the converter will stop the pump, but it will stay watching out the pressure mode ("Sleep" mode).

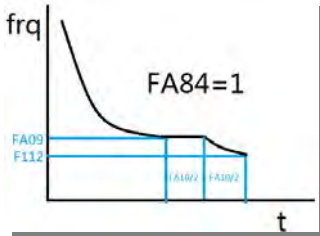





With **FA84**=1, if the pump operates at frequency **FA09** during a HALF of the time period setting in **FA10**, the converter will lower the frequency to **F112** during a HALF of the time period setting in **FA10**, after which it will stop the pump, but it will stay watching out the pressure mode ("Sleep" mode).

The choice of one mode or another to fall asleep depends on the height of the column of water in the outlet pipe, and of the protection that you want to make on the anti-return valve at the outlet of the pump.











ATTENTION!! This control mode varies depending on whether the anti-return valve watching out mode. See [4.2.g.- Anti-return valve control](#).

- Configure parameter in [5.- Pump Control Menu: Parameter list: I / O Configuration](#)
There are no special parameters for this mode.
- Configure parameters of the **PID** in [6.- Pump Control Menu: Parameter List: PID Configuration](#)
The particular parameters of the **PID** for this mode are indicated below:

Param.	Display / Use	Options/Range	Def.
FB43	 : Well pump mode Enable well mode	0 : Activated 1 : Deactivated	0
FA07	 : Sleep mode enable Automatic sleep mode	0 : Activated 1 : Deactivated	1
FA09	 : Freq. threshold sleep Frequency threshold to activate function	F112~F111	5,00 Hz
FA10	 : Delay-time sleep Delay for the Sleep function	0...500 seconds	15 sec.
FA84	 : PID sleep mode Define the sleep mode in the PID	0 : Sleep in FA09 Hz in FA09 during FA10 , it falls asleep. 1 : Sleep under FA09 (F112) Hz in FA09 during a half of the time of FA10 , the frequency of the pump goes down to F112 during a half of the time of FA10 and it falls asleep.	0

- Configure parameters in [7.- Pump Control Menu: Parameter list: Control regulation](#)
The particular parameters for this mode are indicated below:

Param.	Display / Use	Options/Range	Def.
F203	 : Primary setpoint X Possible reference input ways of the first speed "X"	0 : Internal reference (F113) with memory 9 : Control PID	0

	<p>If you define F203=0, you will can control the pump at a specific speed (50Hz by default). The speed is adjusted using the keys  or  on the keyboard (or in F113 parameter) and it stays saved even if the converter is turned off. If you want, you can also regulate the speed by using the keyboard or an external potentiometer.</p> <p>If you define F203=9, It means that a pressure sensor is available, and the pumps speed will be regulated by the PID controller and the pumping will be carried out keeping the SP.</p>
	<p>Starts/hour. It is the responsibility of the installer to limit the number of starts/hour of the pump according to the specifications of the manufacturer of the motor.</p>
	<p>Short start and stop times. It is highly recommended to do short start and stop times when working with pumps submerged in wells. Times of 2 ~ 3 seconds for starting and stopping at powers below 75kW or 3 ~ 5 seconds for powers between 80 ~ 150kW are highly recommended. Therefore, revise that F114 and F115 do not contain disproportionate times, which would damage the pump motor.</p>
	<p>Special start and stop ramps. EURA DRIVES provides a special ramp specially designed for well submersible pumps. Please, read carefully the paragraph 9.2.- Acceleration and deceleration of this manual.</p>
	<p>Protection. It is essential to limit the voltage peaks to a maximum ramp of 500 V/μs and to a maximum tension peak of 1000 V according to EN 60034 (EN 0530 annex 2). Therefore, use filters (dV/dT, ferrites, shocks or sine waves) to reduce voltage peaks, especially when the cable length between the motor and the converter is longer than 50m. Contact our SAT if you have any questions.</p>

1.5.- Solar limitation mode



The mode «Solar Control» takes into account the measurement made by a pyranometer or a plate solar radiation meter, connected to the input *AI1* (V/mA) or *AI2* (mA).

Pumping can be carried out with pressure control or without this control (see parameter **F203**).

In the case of not using a pressure sensor, the pump will operate at the maximum speed set in the **PID** (**FA12**) control unless the solar sensor limits that speed due to the lack of sunlight. **FA09** contains the minimum working frequency setting of the pump for the "Sleep" function.

t0 : There is not enough sun, the pump does not start	t1 : Enough sun detected, the pump starts and its speed is limited by the amount of sun
t2 : There is enough sun, : <u>With pressure control</u> : The pump starts when the “falling sleep” frequency is exceeded and it is limited by the amount of sun or the maximum frequency set. : <u>Without pressure control</u> : The pump starts when the minimum frequency of the pump is exceeded, and it is limited by the amount of sun or the maximum frequency set.	t2a : If a cloud is detected, the speed of the pump is limited to the amount of sun measured.
t3 : The amount of sun declines, the speed of the pump is limited.	t4 : The amount of sun is not enough and the speed of the pump is below the frequency of "falling asleep" (with pressure control) or minimum frequency of the pump (without pressure control), the pump stops.

- Configure parameters in [5.- Pump Control Menu: Parameter list: I / O Configuration](#)
Define if the installation works with a start/stop selector, or with push buttons to increase/decrease the *SP*, or till 4 *SP* different by *DI*'s.
- Configure parameters of the **PID** in [6.- Pump Control Menu: Parameter List: PID Configuration](#)
The particular parameters of the **PID** for this mode are indicated below:

Param.	Display / Use	Options/Range	Def.
FB34	 : Solar mode enable Enables speed limitation mode by solar power	0 : Disabled 1 : Enabled	0
FB35	 : Freq. limiting source Origin for speed limitation	0 : Disabled 1 : <i>AI1</i> : The radiation meter is connected to the terminal of the analog input 1 2 : <i>AI2</i> : The radiation meter is connected to the terminal of the analog input 2	0
FB33	 : Solar filtered time Stability filter for solar limitation	0,0 ~ 100,0 seconds	3,0 sec.

- Configure parameters in [7.- Pump Control Menu: Parameter list: Control regulation](#)
The particular parameters for this mode are indicated below:

Param.	Display / Use	Options/Range	Def.
F203	 : Primary setpoint X Possible reference input ways of the first speed "X"	0 : Internal reference (F113) with memory 9 : Control PID	0





NOTE!! On multiples occasions, the pump with solar control is a well pump; therefore, the same procedure can be used to “fall sleep” (see [1.4.- Well pumps mode](#)), with the same exceptions.



ATTENTION! This control mode varies depending on whether the anti-return valve monitoring function has been activated. See [4.2.g.- Anti-return control](#).



If you define **F203=0**, you will can control the pump at a specific speed (50Hz by default). The speed is adjusted using the keys  or  on the keyboard (or in **F113** parameter) and it stays saved even if the converter is turned off. If you want, you can also regulate the speed by using the keyboard or an external potentiometer.

If you define **F203=9**, It means that a pressure sensor is available, and the pumps speed will be regulated by the *PID* controller and the pumping will be carried out keeping the *SP*.



Starts/hour.

It is the responsibility of the installer to limit the number of starts/hour of the pump according to the specifications of the manufacturer of the motor.



Short start and stop times.

It is highly recommended to do short start and stop times when working with pumps submerged in wells. Times of 2 ~ 3 seconds for starting and stopping at powers below 75kW or 3 ~ 5 seconds for powers between 80 ~ 150kW are highly recommended.

Therefore, revise that **F114** and **F115** do not contain disproportionate times, which would damage the pump motor.



Special start and stop ramps.

EURA DRIVES provides a special ramp specially designed for well submersible pumps. Please, read carefully the paragraph [9.2.- Acceleration and deceleration](#) of this manual.



Protection.

It is essential to limit the voltage peaks to a maximum ramp of 500 V/ μ s and to a maximum tension peak of 1000 V according to EN 60034 (EN 0530 annex 2).

Therefore, use filters (dV/dT, ferrites, shocks or sine waves) to reduce voltage peaks, especially when the cable length between the motor and the converter is longer than 50m. Contact our **SAT** if you have any questions.

1.6.- Fire-fighting mode

In the fire-fighting mode, the simple control mode include two options; The *Jockey pump* is responsible of always keeping a constant pressure in the fire-fighting pipe, and the *fire-fighting pump* itself.

It is possible to combine 1 Jockey pump with one or more fire-fighting pumps, staggered by sectors from a fire control unit or by staggered activation according to mechanical pressure switch settings.

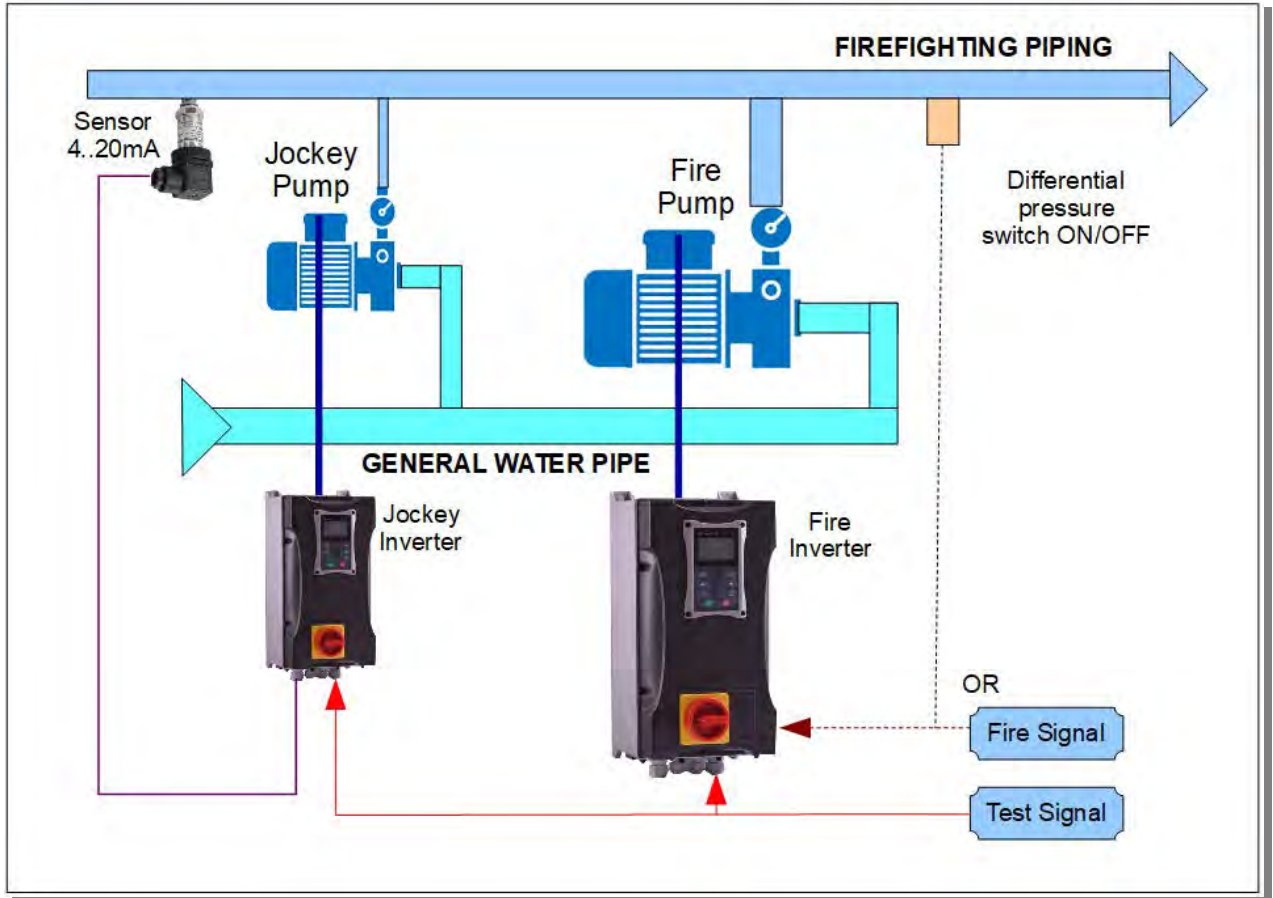





Representation of an installation with a Jockey pump and a fire pump.

1.6.a.- Jockey pump

- Configure parameter in [5.- Pump Control Menu: Parameter list: I / O Configuration](#)
The particular parameters for this mode are indicated below:

Param.	Display / Use	Options/Range	Def.
F316 ~ F321 (F323)	 : Dlx fun. assignment Configure <i>Dlx</i> for the desired states	32: Activate fire mode	

- Configure parameters of the *PID* in [6.- Pump Control Menu: Parameter List: PID Configuration](#)
The particular parameters of the *PID* for this mode are indicated below:

Param.	Display / Use	Options/Range	Def.
FA58	 : FIREMODE pressure Pressure to keep in the Jockey pump	0,00 ~ 10,00 Bar  NOTE: Bar is the default unit; it can be changed in FA34.	8,00 Bar
FA89	 : Pipes charging times Jockey pump start counter	Reading only, from 0 to 50000. It can not be reset!	0
FA62	 : FIREMODE STOP Stop fire mode	0 : It can be stop (fire-fighting mode) 1 : Manual stop (test mode)	0



- Configure parameters in [7.- Pump Control Menu: Parameter list: Control regulation](#)
There are no special parameters for this mode.

1.6.b.- Fire-fighting pump

- Configure parameter in [5.- Pump Control Menu: Parameter list: I / O Configuration](#)
The particular parameters for this mode are indicated below:

<i>Param.</i>	<i>Display / Use</i>	<i>Options/Range</i>	<i>Def.</i>
F316 ~ F321 (F323)	 : Dlx fun. assignment Configure <i>Dlx</i> for the desired states	32: Activate fire mode	

- Configure parameters of the *PID* in [6.- Pump Control Menu: Parameter List: PID Configuration](#)
The particular parameters of the *PID* for this mode are indicated below:

<i>Param.</i>	<i>Display / Use</i>	<i>Options/Range</i>	<i>Def.</i>
FA59	 : FIREMODE Select the mode for fire mode	0: Disabled 1: Fire mode 1 (It operates at the maximum frequency) 2: Fire mode 2 (It operates at FA60 frequency)	1
FA60	 : FIREMODE frequency Frequency in fire mode	F112 ~ F111	50,00 Hz
FA62	 : FIREMODE STOP Stop fire mode	0 : It can be stop (fire-fighting mode) 1 : Manual stop (test mode)	0

- Configure parameters in [7.- Pump Control Menu: Parameter list: Control regulation](#)
There are no special parameters for this mode.

2.- Regulated + fixed

In this operating mode, a pump is controlled by a speed variator, to which the pressure sensor is connected, controlling the auxiliary pumps (3 with **EM30**, 2 with **EP66** or **E2000/E2100**) that start the operation directly with a contactor or with soft starter.

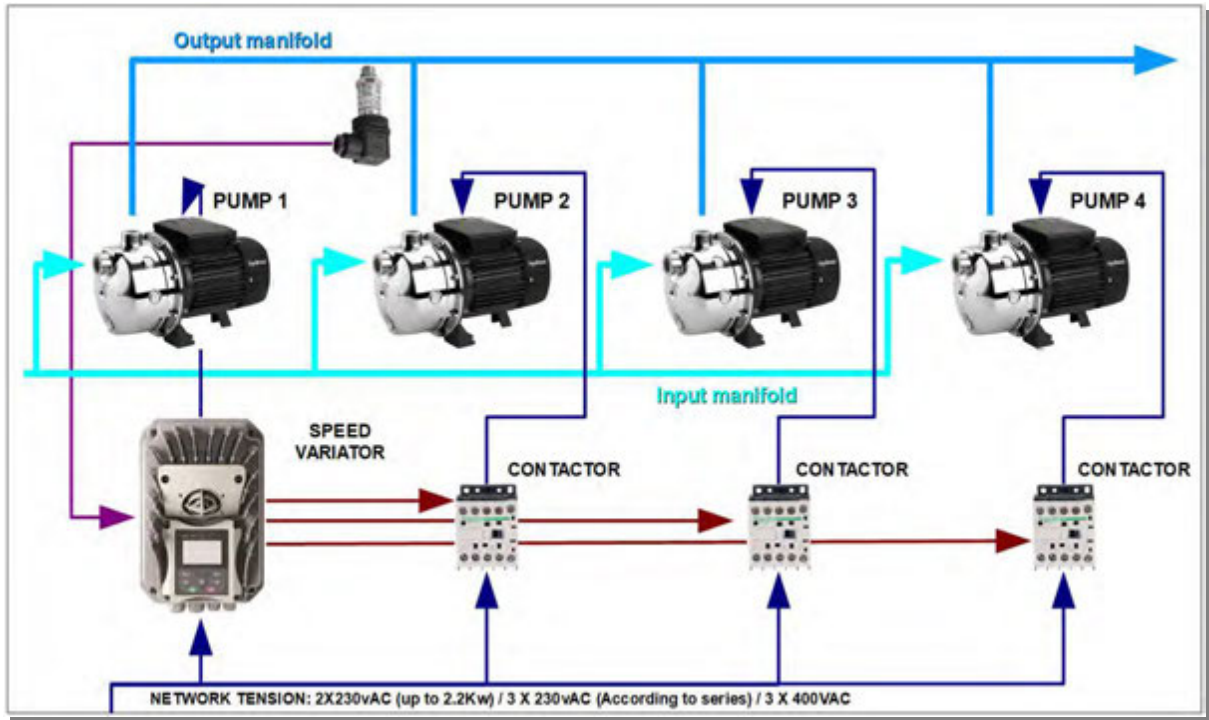

Auxiliary pumps are managed from the speed variator.

This receives the pressure signal from the sensor located in the output manifold, and modulates the speed of the pump to maintain the set pressure. In the case of needing reinforcement, the necessary relays are activated sequentially so that the pressure demanded could be regulated with the pumps that are fixed with contactor.

The installer must pay special attention to this parameter, common to all pumping regulation modes with one regulated pump and the rest of pumps fixed.

Param.	Display / Use	Options/Range	Def.
FA98	 : Interchange VFD/POWER Regulated pump stop when a fixed pump start	0 : Disabled 1 : Enabled	1

Depending on the power of the fixed pumps, it may be necessary to activate or deactivate this function.

If **FA98 = 0**, the regulated pump will not stop when a fixed pump for pressure reinforcement is connected. This can cause a significant momentary overpressure in the installation, until the regulated pump can compensate it by lowering its speed.











If **FA98 = 1**, the regulated pump will stop when a fixed pump for pressure reinforcement is connected, and it will make the **PID** control again after two seconds of the activation of the auxiliary pump

Extended information of the function is available as well as some operating graphs in paragraph [9.4.- Deactivation of fixed auxiliary pumps.](#)

2.1.- Regulated + fixed WITHOUT rotation

With this working mode, the rotation of the auxiliary pumps is not established, entering in operation in the same order that is established by wiring and configuration.

- Configure parameters in [5.- Pump Control Menu: Parameter list: I / O Configuration](#)
There are no special parameters for this mode.
- Configure the parameters of the *PID* in [6.- Pump Control Menu: Parameter List: PID Configuration](#)
The particular parameters of the *PID* for this mode are indicated below:













Param.	Display / Use	Options/Range	Def.
FA00	 : PID Controller mode Controller settings	5 : Regulated + fixed mode (WITHOUT <i>Slave</i> rotation)	0
FA30	 : Inv. Pump startdelay Starting delay for auxiliary pump with pump regulated at 100%	2,0 ~ 999,9 seconds	20,0 sec.
FA31	 : Pump startdelay Time with pump at 100% before timing the start of a fixed pump	0,1 ~ 999,9 seconds	30,0 sec.
FA32	 : Pump stopdelay Delay to stop a pump at the frequency of falling asleep (FA09)	0,1 ~ 999,9 seconds	30,0 sec.
FA36	 : Relays 1 Relay 1	0 : Not available 1 : Available	0
FA37	 : Relays 2 Relay 2	0 : Not available 1 : Available	0
FA82	 : Relays 3 Relay 3	0 : Not available 1 : Available	0
FA47	 : Rel. 1 Start sequence Relay 1 start sequence	1 ~ 20	20
FA48	 : Rel. 2 Start sequence Relay 2 start sequence	1 ~ 20	20
FA83	 : Rel. 3 Start sequence Relay 3 start sequence	1 ~ 20	20
FA98	 : Interchange VFD/POWER Regulated pump stop when a fixed pump start	0 : Disabled 1 : Enabled	1

- Configure parameters in [7.- Pump Control Menu: Parameter list: Control regulation](#)
There are no special parameters for this mode.

2.2.- Regulated + fixed, rotation by time of use

With this working mode, the rotation of the auxiliary pumps is established, and this is carried out after the time programmed in **FA25**. The time controlled is the operating time of the regulated pump.

- Configure parameters in [5.- Pump Control Menu: Parameter list: I / O Configuration](#)
There are no special parameters for this mode.
- Configure the parameters of the **PID** in [6.- Pump Control Menu: Parameter List: PID Configuration](#)
The particular parameters of the **PID** for this mode are indicated below:











<i>Param.</i>	<i>Display / Use</i>	<i>Options/Range</i>	<i>Def.</i>
FA00	 : PID Controller mode Controller settings	6 : Regulated + fixed mode (rotation of Slaves by time of operation)	0
FA30	 : Inv. Pump startdelay Delay to start an auxiliary pump in case of need	2,0 ~ 999,9 seconds	20,0 sec.
FA31	 : Pump startdelay Delay to start a linked pump in case of need	0,1 ~ 999,9 seconds	30,0 sec.
FA32	 : Pump stopdelay Delay to stop a linked pump if it is not necessary	0,1 ~ 999,9 seconds	30,0 sec.
FA36	 : Relays 1 Relay 1	0 : Not available 1 : Available	0
FA37	 : Relays 2 Relay 2	0 : Not available 1 : Available	0
FA82	 : Relays 3 Relay 3	0 : Not available 1 : Available	0
FA47	 : Rel. 1 Start sequence Relay 1 start sequence	1 ~ 20	20
FA48	 : Rel. 2 Start sequence Relay 2 start sequence	1 ~ 20	20
FA83	 : Rel. 3 Start sequence Relay 3 start sequence	1 ~ 20	20
FA98	 : Interchange VFD/POWER Regulated pump stop when a fixed pump start	0 : Disabled 1 : Enabled	1
FA24	 : Time units hours/min. Unit for time control to fall asleep	0 : Hours 1 : Minutes	1
FA25	 : Switchover interval Time for alternation	1 ~ 9999	100

- Configure parameters in [7.- Pump Control Menu: Parameter list: Control regulation](#)
There are no special parameters for this mode.

2.3.- Regulated + fixed, rotation after falling asleep the regulated

With this working mode, the rotation of the auxiliary pumps is established, and this is carried out each time that the regulated pump "sleeps". The time that is controlled is the operation time of the regulated pump.

- Configure parameters in [5.- Pump Control Menu: Parameter list: I / O Configuration](#)
There are no special parameters for this mode.
- Configure the parameters of the *PID* in [6.- Pump Control Menu: Parameter List: PID Configuration](#)
The particular parameters of the *PID* for this mode are indicated below:

Param.	Display / Use	Options/Range	Def.
FA00	 : PID Controller mode Controller settings	7 : Regulated + fixed mode (rotation of <i>Slaves</i> when the <i>Master</i> falls asleep)	0
FA30	 : Inv. Pump startdelay Starting delay for auxiliary pump with pump regulated at 100%	2,0 ~ 999,9 seconds	20,0 sec.
FA31	 : Pump startdelay Time with pump at 100% before timing the start of a fixed pump	0,1 ~ 999,9 seconds	30,0 sec..
FA32	 : Pump stopdelay Delay to stop a pump at the frequency of falling asleep (FA09)	0,1 ~ 999,9 seconds	30,0 sec..
FA36	 : Relays 1 Relay 1	0 : Not available 1 : Available	0
FA37	 : Relays 2 Relay 2	0 : Not available 1 : Available	0
FA82	 : Relays 3 Relay 3	0 : Not available 1 : Available	0
FA47	 : Rel. 1 Start sequence Relay 1 start sequence	1 ~ 20	20
FA48	 : Rel. 2 Start sequence Relay 2 start sequence	1 ~ 20	20
FA83	 : Rel. 3 Start sequence Relay 3 start sequence	1 ~ 20	20
FA98	 : Interchange VFD/POWER Regulated pump stop when a fixed pump start	0 : Disabled 1 : Enabled	1

- Configure parameters in [7.- Pump Control Menu: Parameter list: Control regulation](#)
There are no special parameters for this mode.

3.- All regulated

This is the most common method for pumps working in *Pressure Groups* also known as *Linked Pumps* or *Pump Chain*. All pumps are controlled by speed variator, and are linked or relieved to maintain the pressure of the installation in the established limits.

In this mode, you can have up to **15 pumps** linked in the same installation.

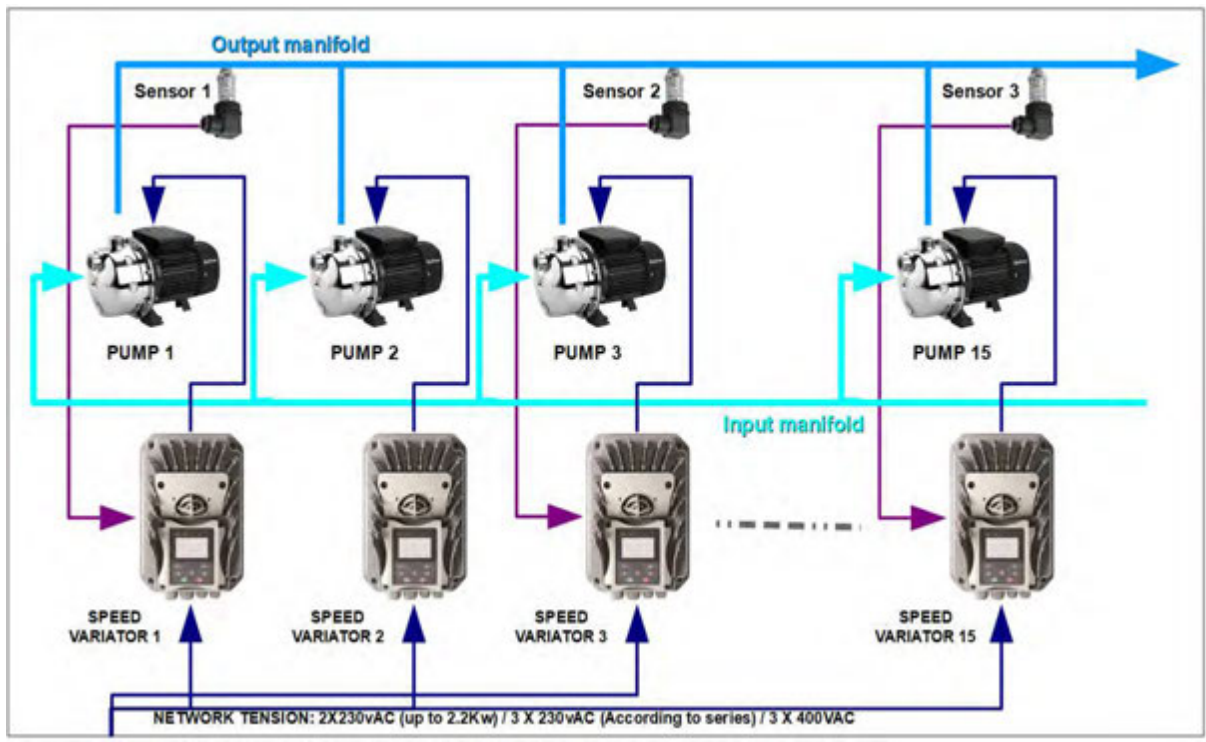

NOTE : The linked pumps can work in different modes. The parameter **FA34** configures the unit measurement that you want. For example; pressure (**FA34=1/2/3=Mpa/Bar/Psi**), or in level (**FA34=0/4/5=%/cm/M**) or in flow rate (**FA34=6/7=cm/sec./M/sec.**) or in heating/cooling (**FA34=8=°C**).



As you can see in the image above, it is **NOT NECESSARY** to place a sensor for each pump. But if it is convenient that there is more than one in the installation, to prevent the pressure group from not stopping if a sensor breaks down or if an converter that has a pressure sensor connected is switched off.

3.a.- Connection for communications

The converters of the linked pumps that form the pressure group communicate with each other via a proprietary bus CAN (that is, it can not be managed by the installer). The communication port varies according to the converter model and the size of these, but it is easily accessible. Some pictures are included for helping you:

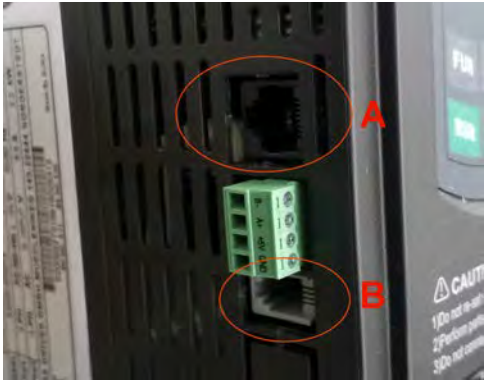
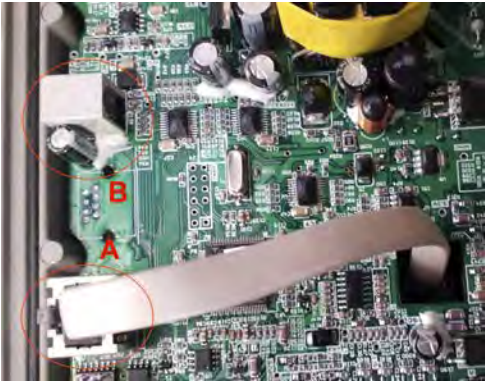
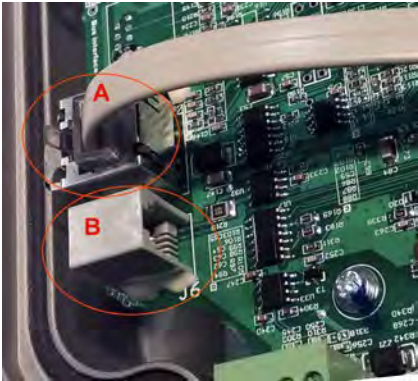
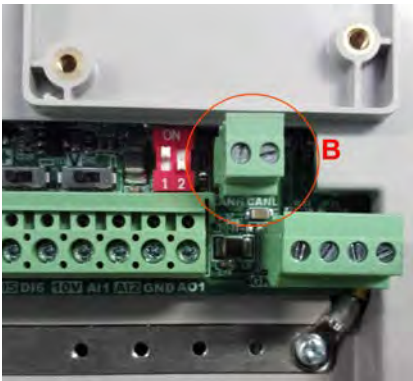
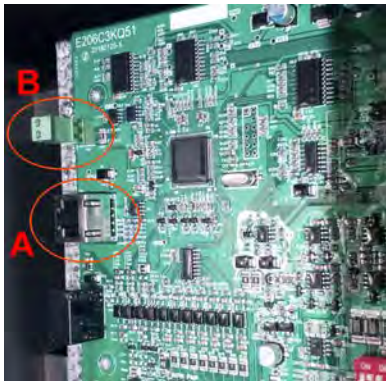
 <p style="text-align: center;">Series E2000, sizes E2 to E6</p>	<p>A = DATA port : Connection for the keyboard Type 8-pin RJ45 In E2000 : for external keyboard connection</p> <p>B = CAN port : Interconnection between equipment Type RJ9 (depending on the models and sizes) of 4-pin Plug-in screw connector (according to size)</p>
 <p style="text-align: center;">Series EM30 Sizes J1</p>	 <p style="text-align: center;">Series EM30 Sizes J2</p>
 <p style="text-align: center;">Series EP66 plastic cover series</p>	 <p style="text-align: center;">Series EP66 metallic cover series</p>

Therefore, the interconnection between equipment is done through a simple telephone cable pin to pin between equipment.

	<p>As a tip, due to the fragility of the telephone cable, it is advisable to protect it with an appropriate tube. It is also a good option to join all the threads of the same color, one of each cable, in an isolated terminal, and leave the four terminals of one of the converters.</p>
---	--

3.b.- Automatic synchronization

A whole system has been developed to synchronize the settings and avoid having to repeat the same settings for all the pumps that make up the pressure group.

For example, if another pump is added to the pressure group, or if you want to set all the pumps at the same time, at the commissioning.

Two synchronization alternatives are possible and they are described in the following paragraphs.





3.b.1- Initial synchronization to the commissioning

If the entire pressure group has to be put into service at the same time, there is a very interesting procedure to gain a lot of time and not have to repeat the same programming on all the drives. The following steps must be executed:

1° : Relate the motor with the converter:

Follow the procedure indicated in [II.d2- Motor autotuning](#) to perform the automatic calibration of the motor regulation in each pump.

2° : Parameterize the minimum synchronization values in **EACH CONVERTER**:

Param.	Display / Use
F900	 : Inv. adress asignment Electronic address (unit number) of the converter Enter the unit number following the last parameterized (1 ~ 15)  VERY IMPORTANT : DO NOT DUPLICATE THE ADDRESSES!!
F203	 : Primary setpoint X Possible reference input ways of the first speed "X" Enter the setpoint source set in the installation (usually F203=9) (See 7.- Pump Control Menu: Parameter list: Control regulation in case of doubt)
FA00	 : PID Controller mode Controller configuration Enter the number that represents the pumping function in the chain (See 6.- Pump Control Menu: Parameter List: PID Configuration in case of doubt)



3° : Once all the converters are parameterized properly, set the synchronization of parameters in each one (except for the one defined with **F900 = 1**).

Param.	Display / Use
FA99	 : Param. synchronizing It allows to synchronize from a <i>Slave</i> the parameters of regulation and control of the <i>Master</i> (See 3.b.3- Synchronized parameters to know the ones that are synchronized)

4° : From here, parameterize in the *Master*.

The *Master* is the one with **F900 = 1**, the display shows an **M**, in the lower left corner.

All the settings that are made in this *Master* will be automatically synchronized in the *Slaves*, the display shows an **S**, in the lower left corner.

	Warning! Not all pump parameters are synchronized. See in 3.b.3- Synchronized parameters the ones that synchronize.
	If the pump system has been configured with the <i>MANUAL / AUTO</i> function, the selector must be activating the input defined as <i>AUTO</i> .





3.b.2- Synchronization after adding a converter to the chain

Whenever a converter is added to a pump chain, the following steps must be followed in the new equipment:

1° : Relate the motor with the converter:

Follow the procedure indicated in [II.d2- Motor autotuning](#) to perform the automatic calibration of the motor regulation.

2° : Parameterize the minimum synchronization values:

<i>Param.</i>	<i>Display / Use</i>
F900	 : Inv. adress asignment Electronic address (unit number) of the converter Enter the unit number following the last parameterized (1 ~ 15)  VERY IMPORTANT : DO NOT DUPLICATE THE ADDRESSES!!
F203	 : Primary setpoint X Possible reference input ways of the first speed "X" Enter the setpoint source set in the installation (usually F203=9) (See 7.- Pump Control Menu: Parameter list: Control regulation in case of doubt)
FA00	 : PID Controller mode Controller configuration Enter the number that represents the pumping function in the chain (See 6.- Pump Control Menu: Parameter List: PID Configuration in case of doubt)
FA99	 : Param. synchronizing It allows to synchronize from a <i>Slave</i> the parameters of regulation and control of the <i>Master</i> (See 3.b.3- Synchronized parameters to know the ones that are synchronized)

3° : The added converter will take the current values recorded in the converter with the address **F900** = 1, and if it is not active, from the converter acts as *Master* in the installation.

	<p>Warning! Not all pump parameters are synchronized. See in 3.b.3- Synchronized parameters the ones that synchronize.</p>
---	--

3.b.3- Synchronized parameters

The parameters that are automatically synchronized in all the converters of the chain, when manually changing any of them, are the following:

PARAM.	FUNCTION	SETTING RANGE	DEFAULT SETTINGS	E2000/ E2100	EP66	EM30
F114	Acceleration ramp 1 (sec.)	0,1 – 3.000 sec.	According to converter size	X	X	X
F115	Deceleration ramp 1 (sec.)	0,1 – 3.000 sec.	According to converter size	X	X	X
F131	Display: Selection of the operating parameters to be displayed during the "START" status (motor running)	0 - 8192	0 + 1 + 2 + 4 + 8 = 15	X	X	X
F132	Display: Selection of the operating parameters to be displayed during the "STOP" status (motor stopped)	0 - 2048	0 + 2 + 4 = 6	X	X	X
F213	Restart after a power drop	0 - 1	0	X	X	X
F215	Restart delay after a power drop (sec.)	0,1 – 3000,0 sec.	60,0 sec.	X	X	X
F400	Range definition AI1 – Low limit (V)	0,00V – F402	0,00 V	X	X	X
F406	Range definition AI2 – Low limit (V)	0,00V – F408	0,00 V	X	X	X
F438	Input type for AI1	0 - 1	0	X	X	
F439	Input type for AI2	0 - 1	1	X	X	
F647	Change language (of the external screen)	0 - 10	0	X	X	X
FA00 ~ FA98	All pumping parameters, group A					
FB10 ~ FB43	All pumping parameters, group B  EXCEPT FB19!!					
FD00 ~ FD81	All pumping parameters, group D (Time control) See 4.2.e.- Timer					

This parameter changes and is synchronized in a special way: :





PARAM.	FUNCTION	SETTING RANGE	DEFAULT SETTINGS	E2000/ E2100	EP66	EM30
FA09	Frequency threshold to activate the sleep function	F112~F111	5,00 Hz	X	X	X

If the automatic calibration of the well or solar pump has been made (see [4.2.f.- Solar/well pump autotuning](#)), the result of this autotuning is inscribed in the parameter FA09 mentioned.

3.1.- Regulated fixed

Select this mode if you do not want to rotate the pumps. The pump with unit number 1 will always enter the first one, and the activation and stop sequence of the installed pumps will be the one corresponding to the unit number parameterized in parameter **F900**.

- Configure parameters in [5.- Pump Control Menu: Parameter list: I / O Configuration](#)
There are no special parameters for this mode.
- Configure the parameters of the **PID** in [6.- Pump Control Menu: Parameter List: PID Configuration](#)
The particular parameters of the **PID** for this mode are indicated below:

Param.	Display / Use	Options/Range	Def.
FA30	 : Inv. Pump startdelay Starting delay for auxiliary pump with pump regulated at 100%	2,0 ~ 999,9 seconds	20,0 sec.
FA31	 : Pump startdelay Time with pump at 100% before timing the start of a fixed pump	0,1 ~ 999,9 seconds	30,0 sec.
FA32	 : Pump stopdelay Delay to stop a pump at the frequency of falling asleep (FA09)	0,1 ~ 999,9 seconds	30,0 sec.
FA44	 : M/S control mode It establishes the behavior of the <i>Slave</i> with respect to the <i>Master</i> being linked	0: <i>Slave</i> Setpoint = <i>Master</i> Setpoint The <i>Slave</i> operates in a twin way to the <i>Master</i> , regulates his speed at the same time 1: <i>Slave</i> Setpoint = <i>PID</i> setpoint The <i>Slave</i> operates independently to the <i>Master</i> , <i>PID</i> regulates your speed	0
FA99	 : Param. synchronizing It allows to synchronize from a <i>Slave</i> the parameters of regulation and control of the <i>Master</i> (See 3.b.3- Synchronized parameters to know the ones that are synchronized)	0 : Disabled The <i>Slave</i> keeps its own parameters 1 : Activated The <i>Slave</i> copies the parameters of the <i>PID</i> and of the regulation of the <i>Master</i> (* See 3.b.- Automatic synchronization	0







- Configure parameters in [7.- Pump Control Menu: Parameter list: Control regulation](#)
There are no special parameters for this mode.

	If the pump system has been configured with the MANUAL / AUTO function, the rotation conditions of the function must be taken into account.
---	--

3.2.- Multi-master rotation by time of use of the *Master*

Select this mode if you wish to rotate pumps. The starting sequence of the pumps will rotate taking into account the operating time of the *Master* pump, that is, of the first pump that has entered into operation, and will transfer the *Master* function to the next available pump, according to parameter **F900**, in operation or asleep.

- Configure parameters in [5.- Pump Control Menu: Parameter list: I / O Configuration](#)
There are no special parameters for this mode.
- Configure the parameters of the *PID* in [6.- Pump Control Menu: Parameter List: PID Configuration](#)
The particular parameters of the *PID* for this mode are indicated below:

<i>Param.</i>	<i>Display / Use</i>	<i>Options/Range</i>	<i>Def.</i>
FA30	 : Inv. Pump startdelay Starting delay for auxiliary pump with pump regulated at 100%	2,0 ~ 999,9 seconds	20,0 sec.
FA31	 : Pump startdelay Time with pump at 100% before timing the start of a fixed pump	0,1 ~ 999,9 seconds	30,0 sec.
FA32	 : Pump stopdelay Delay to stop a pump at the frequency of falling asleep (FA09)	0,1 ~ 999,9 seconds	30,0 sec.
FA44	 : M/S control mode It establishes the behavior of the <i>Slave</i> with respect to the <i>Master</i> being linked	0: <i>Slave</i> Setpoint = <i>Master</i> Setpoint The <i>Slave</i> operates in a twin way to the <i>Master</i> , regulates his speed at the same time 1: <i>Slave</i> Setpoint = <i>PID</i> setpoint The <i>Slave</i> operates independently to the <i>Master</i> , <i>PID</i> regulates your speed	0
FA99	 : Param. synchronizing It allows to synchronize from a <i>Slave</i> the parameters of regulation and control of the <i>Master</i> (See 3.b.3- Synchronized parameters to know the ones that are synchronized)	0 : Disabled The <i>Slave</i> keeps its own parameters 1 : Activated The <i>Slave</i> copies the parameters of the <i>PID</i> and of the regulation of the <i>Master</i> (* See 3.b.- Automatic synchronization)	0
FA24	 : Time units hours/min. Unit for time control to fall asleep	0 : Hours 1 : Minutes	1
FA25	 : Switchover interval Time for alternation	1 ~ 9999	100





- Configure parameters in [7.- Pump Control Menu: Parameter list: Control regulation](#)
There are no special parameters for this mode.

	If the pump system has been configured with the <i>MANUAL / AUTO</i> function, the rotation conditions of the function must be taken into account.
---	--

3.3.- Multi-master rotation after falling asleep the *Master*

Select this mode if you wish to rotate pumps. The starting sequence of the pumps will rotate when the *Master* pump falling sleep, that is, the first pump that has started operating, and will transfer the *Master* function to the next available pump, according to parameter **F900**, which will necessarily be **asleep**.

- Configure parameters in [5.- Pump Control Menu: Parameter list: I / O Configuration](#)
There are no special parameters for this mode.
- Configure the parameters of the *PID* in [6.- Pump Control Menu: Parameter List: PID Configuration](#)
The particular parameters of the *PID* for this mode are indicated below:

<i>Param.</i>	<i>Display / Use</i>	<i>Options/Range</i>	<i>Def.</i>
FA30	 : Inv. Pump startdelay Starting delay for auxiliary pump with pump regulated at 100%	2,0 ~ 999,9 seconds	20,0 sec.
FA31	 : Pump startdelay Time with pump at 100% before timing the start of a fixed pump	0,1 ~ 999,9 seconds	30,0 sec.
FA32	 : Pump stopdelay Delay to stop a pump at the frequency of falling asleep (FA09)	0,1 ~ 999,9 seconds	30,0 sec.
FA44	 : M/S control mode It establishes the behavior of the <i>Slave</i> with respect to the <i>Master</i> being linked	0: <i>Slave</i> Setpoint = <i>Master</i> Setpoint The <i>Slave</i> operates in a twin way to the <i>Master</i> , regulates his speed at the same time 1: <i>Slave</i> Setpoint = <i>PID</i> setpoint The <i>Slave</i> operates independently to the <i>Master</i> , <i>PID</i> regulates your speed	0
FA99	 : Param. synchronizing It allows to synchronize from a <i>Slave</i> the parameters of regulation and control of the <i>Master</i> (See 3.b.3- Synchronized parameters to know the ones that are synchronized)	0 : Disabled The <i>Slave</i> keeps its own parameters 1 : Activated The <i>Slave</i> copies the parameters of the <i>PID</i> and of the regulation of the <i>Master</i> (* See 3.b.- Automatic synchronization	0

- Configure parameters in [7.- Pump Control Menu: Parameter list: Control regulation](#)
There are no special parameters for this mode.

	If the pump system has been configured with the <i>MANUAL / AUTO</i> function, the rotation conditions of the function must be taken into account.
---	--

4.- Auxiliary and protection functions

4.1.- Protection functions

The protection functions are intended to perform safety supervisions on the pumping system.

Except for the access protection that is defined in paragraph [4.1.a.- Protection of access to the Pump Control](#), which allows blocking access to anyone outside the pumping system, and anti-blockage [4.1.b.- Anti-blockage function](#) that supervises the possible blockage of the pump by a solid body, the operation of the others can be summarized in the following paragraphs:

4.1.a.- Protection of access to the Pump Control

Protects access to pump parameterization.

If the value is 0, the parameterization menu of the pump control is unprotected.

With any other number previously inserted, the access will be protected, and the code must be entered to access the pump menu.



ATTENTION!! Write down the protection number when you set it, it is not possible to reset the menu if that number is forgotten

4.1.b.- Anti-jam function

This function is normally used in single-pump installations, and working with waste or fecal water.

If it is activated (**FB48** = 1), the power of the motor of the pump is monitored, the power will increase when the pump seizes up due to the obstruction of a solid body.

If the power measured in the pump (**F102**) exceeds **FB49** the supervision time **FB50**, the pump will stop during the time **FB51**, the direction of rotation will be reversed at the speed **F113** during the time **FB52**, it will stop again during the time **FB51** reversing the direction of rotation at speed **F113** during the time **FB52**.

At the end of this cycle, which is called "unblocking attempt" if the overcurrent persists, another unblocking movement will be attempted, as long as the number of attempts does not exceed those set in **FB53**. If this happens, alarm **75:ErJA** will be activated on the display and the pump will stop.

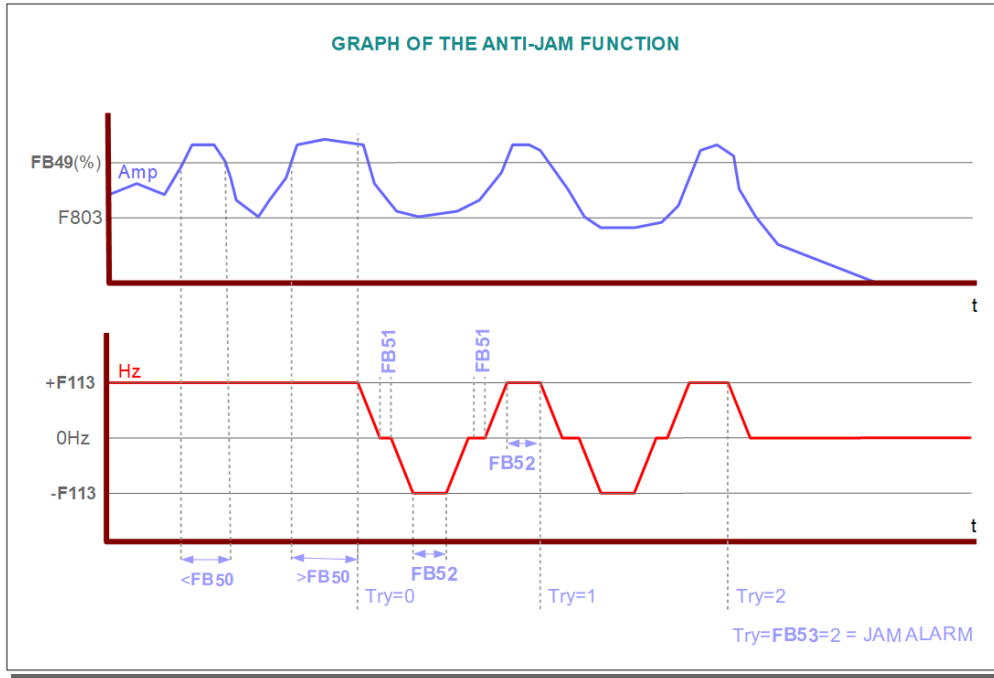

Function graph of anti-jam function.

- Configure parameters in [5.- Pump Control Menu: Parameter list: I / O Configuration](#)
There are no special parameters for this mode.
- Configure the parameters of the **PID** in [6.- Pump Control Menu: Parameter List: PID Configuration](#)
The particular parameters of the **PID** for this mode are indicated below:

Param.	Display / Use	Options/Range	Def.
FB48	: Anti-jam function Jam detection in the pump	0 : Disabled 1 : Enabled	0
FB49	: Jam overload Overload as of which it is considered a jam	100 ~ 150 % (of the power motor from F803)	115 %
FB50	: Time jam overload Jam detection time with FB49	0,1 ~ 10,0 seconds	10,0 sec.
FB51	: Time jam stopped Detection time between turning inversion	0,0 ~ 30,0 seconds	3,0 sec.
FB52	: Time jam started Operating time to unblock the jam	1,0 ~ 30,0 seconds	3,0 sec.
FB53	: Unblocking attempts Number of times the unblocking operation is done before activating the alarm	1 ~ 10 times	3

**NOTE.**

"Unblocking attempt" means the complete cycle consisting of stopping the pump by turning it in the correct direction, reversing the direction of rotation, stopping and turning again in the correct direction.

- Configure parameters in [7.- Pump Control Menu: Parameter list: Control regulation](#)
There are no special parameters for this mode.

**Additional information.**

Special attention must be paid to parameter **F203**.

If the PID (**F203=9**) is used, the speed control is determined by the reaction of the pressure measured by the installation sensor.

Normally, with sewage or wastewater, this control is not carried out in this way, but by fixed speed adjusted by keyboard or communications directly on parameter **F113**.

If this is the case, put **F203 = 0**.

If the speed is adjusted by external potentiometer, for example connected to AI1, set **F203 = 1**.

4.1.c.- Leak detection

The leak detection is used to supervise the installation and generate an alarm in case of detecting a loss or lack of non-recoverable pressure. This detection is carried out at two important moments of operation; The filling, if this is activated, and in the normal regulation within the pressure cycle.

In the case of detecting lack of pressure in the installation, the system will stop immediately, activating the **alarm 69:EP6**, and **will not do the pressure recovery sequence indicated below**.

To do this, you must adjust the loss of pressure supported in a determined time and the number of retries before stopping the pump system and generate the corresponding alarm.

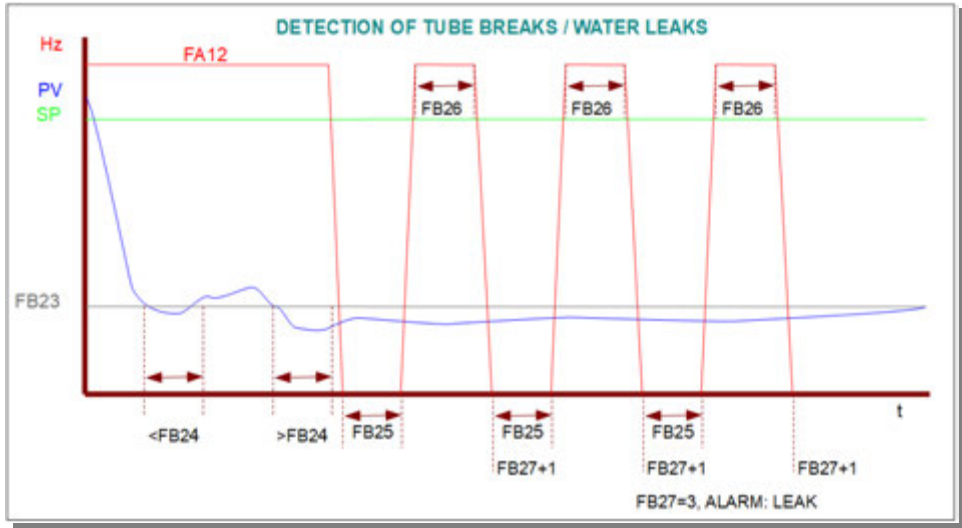

Sequence of pressure recovery before generating the **alarm 69:EP6**

Si $PV > SP$, the sequence is interrupted and regulation begins.

- Configure

parameters in [5.- Pump Control Menu: Parameter list: I / O Configuration](#)
There are no special parameters for this mode.

- Configure the parameters of the **PID** in [6.- Pump Control Menu: Parameter List: PID Configuration](#)
The particular parameters of the **PID** for this mode are indicated below:





Param.	Display / Use	Options/Range	Def.
FB23	: Leak press. detection Pressure for leak detection	0,0 ~ 100,0	0,0
FB24	: Leak detection time Detection time 1 (To pause)	0,0 ~ 300,0 seconds	5,0 sec.
FB25	: Leak detection time2 Detection time 2 (To pause)	0,0 ~ 300,0 seconds	5,0 sec.
FB26	: Leak detection time3 Detection time 3 (Running)	0,0 ~ 300,0 seconds	5,0 sec.
FB27	: Leakage det. Cycle Leak detection supervision cycles	2 ~ 10	3

- Configure parameters in [7.- Pump Control Menu: Parameter list: Control regulation](#)
There are no special parameters for this mode.

4.1.d.- Dry running

With this protection, it is possible to detect the dry running of the pump. The dry running condition can be caused by a jam in the pump's inlet pipe or manifold, or because a closed valve has been left.

- Configure parameters in [5.- Pump Control Menu: Parameter list: I / O Configuration](#)
There are no special parameters for this mode.
- Configure the parameters of the **PID** in [6.- Pump Control Menu: Parameter List: PID Configuration](#)
The particular parameters of the **PID** for this mode are indicated below:

Param.	Display / Use	Options/Range	Def.
FB16	 : Dry detection Detection of dry operation	0 : Disabled 1 : Enabled	0
FB17	 : Dry pressure Pressure for dry operation	0,0 ~ 100,0 %	0,0 %
FB18	 : Dry delay Pressure for dry operation	0,0 ~ 300,0 seconds	60 sec.
FB19	 : Dry current threshold Current for dry operation	0,1 ~ 1000,0 A	A

- Configure parameters in [7.- Pump Control Menu: Parameter list: Control regulation](#)
There are no special parameters for this mode.



NOTE!! Only the efficiency of the detection of dry operation in pumping groups in which all the pumps have the same inlet manifold is guaranteed.

Another effective way of detecting dry running is to provide the pump with an **NTC/PTC** temperature sensor that carries out the protection by detecting the over-temperature.

To do this, you must indicate the input used in [5.- Pump Control Menu: Parameter list: I / O Configuration](#)

Param.	Display / Use	Options/Range	Def.
F316 ~ F321 (F323)	 : DIx fun. assignment Configure DIx for the desired state	37 : NTC / NO 38 : PTC / NC	

4.1.e.- Filling of the installation

The filling function of the installation, if it is selected, is only active the first time the pressure group is activated, without *PV* having previously reached *SP*. In general, this happens the first time the pumping equipment is turned on and the pressure group is activated, when the pipes of the installation are discharged.

If it is activated, the operation is shown in the following graphs:

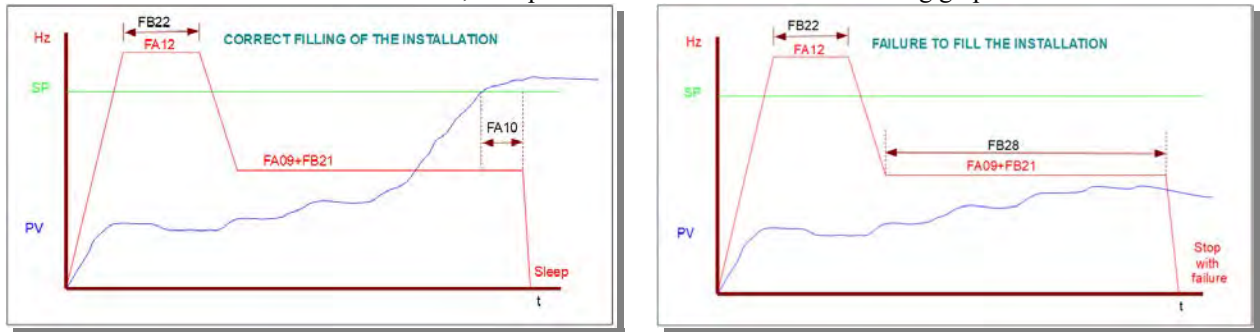

- Configure parameters in [5.- Pump Control Menu: Parameter list: I / O Configuration](#)
There are no special parameters for this mode.
- Configure the parameters of the *PID* in [6.- Pump Control Menu: Parameter List: PID Configuration](#)
The particular parameters of the *PID* for this mode are indicated below:

Param.	Display / Use	Options/Range	Def.
FB20	: Fill Installation Filling of the installation	0 : Disabled 1 : Enabled	0
FB21	: Pipe Fill Frequency Additional frequency to FA09 for filling	0 ~ FA12	5,00 Hz
FB22	: Prefill time Time needed to attempt the filling	0,0 ~ 300,0 seconds	60,0 sec.
FB28	: Fill timeout Wait time for filling	1 ~ 3000 minutes	10 min

- Configure parameters in [7.- Pump Control Menu: Parameter list: Control regulation](#)
There are no special parameters for this mode.

4.2.- Auxiliary functions

The auxiliary functions can be combined with almost all types of pumping regulation described in this manual.

4.2.a.- Water flow detection

This function, if it is enabled, supervises the excessive stability of the system over time, and if **PV** is stable during the time **FA79**, a fictitious **SP** (**SP+FA80**) is automatically generated during the time **FA81**, after which the modified **SP** returns to the previous **SP**. If the demand of the installation consumes that overpressure, it is that the pumping is active and there is a water flow.

On the contrary, if the overpressure persists until making the frequency of the pump lowered to **FA09**, it will fall asleep after the **FA10** waiting time.

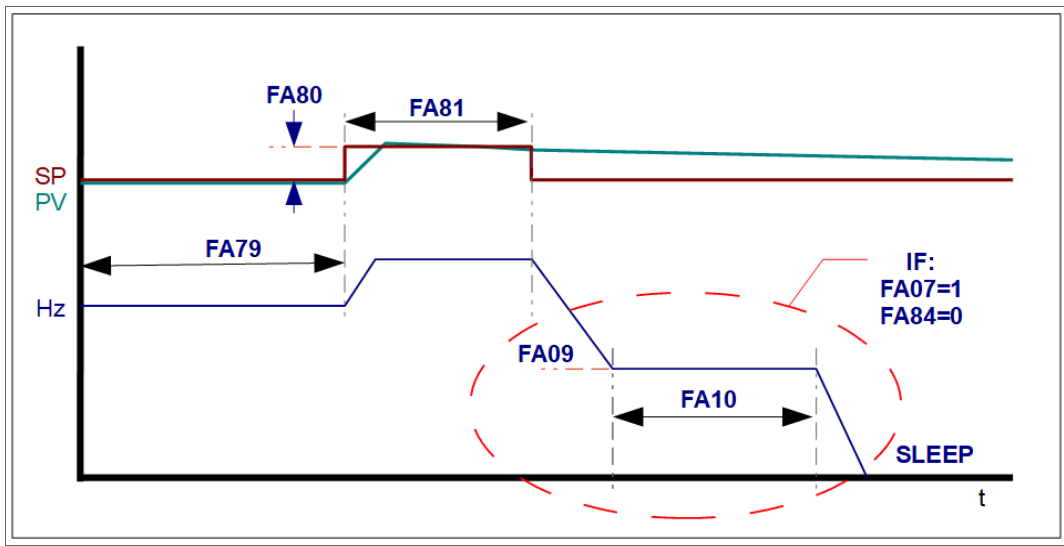

Flow control operation diagram.

- The particular parameters for this mode are indicated below:

Param.	Display / Use	Options/Range	Def.
FA78	: Flow detection Water flow monitoring	0 : Disabled 1 : Enabled	0
FA79	: Flow scan time Interval for flow scan	1 ~ 60000 minutes	60 min.
FA80	: Pressure compensation Pressure to compensate (s/unit in FA34)	0,1 ~ 10,0	2,00
FA81	: NoFlow restart delay Delay of the restart without flow	0,0 ~ 3000,0 seconds	10 sec.

4.2.b.- Cleaning of the pump

This function can only be used in manual mode, so you must have the corresponding "Manual" input activated. The way to use the "Manual" input is indicated in paragraph [4.2.c.- MANUAL / AUTOMATIC control](#) of this manual.

When the input is activated, the pump operates in the forward direction during the time **FB31**, it stops for the time **FB32**, it runs in the opposite direction during the time **FB31**, it do again the pause **FB32**, and so on indefinitely while the input is activated.

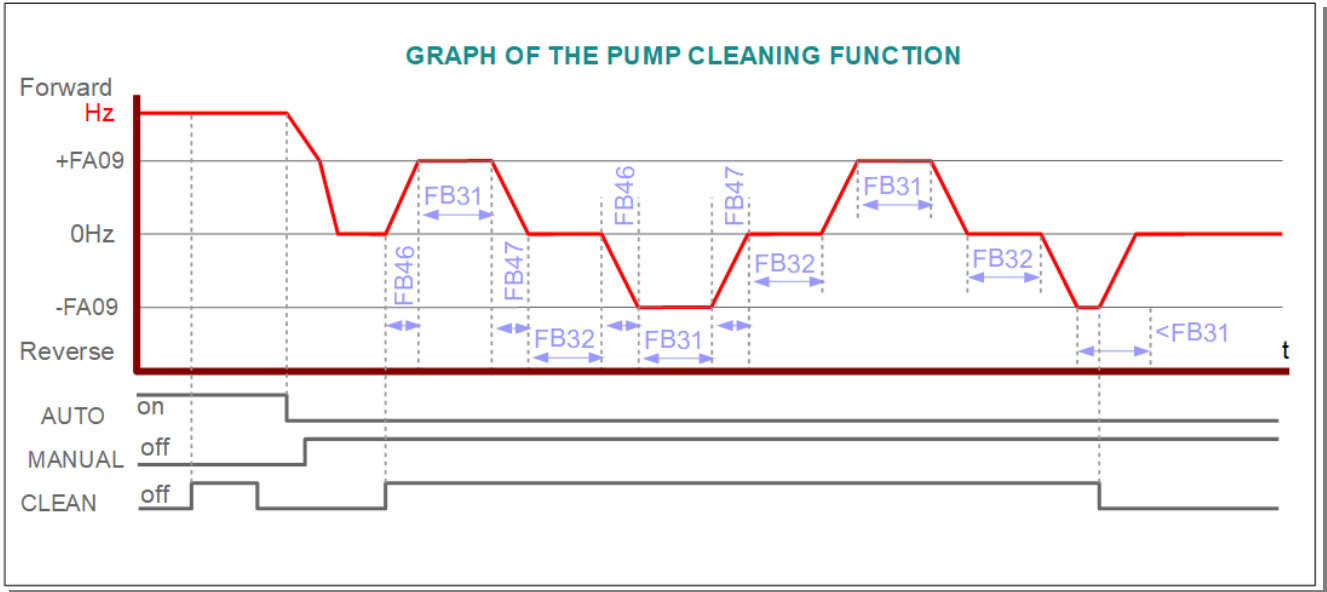

Operating diagram of the pump cleaning function.

To avoid overpressure in the circuit, in case of operating with pressure control, the speed of the pump will not exceed the frequency set in **FA09** (frequency of "falling asleep"). Acceleration and deceleration ramps below this frequency are regulated by **FB46** and **FB47**.

Param.	Display / Use	Options/Range	Def.
F316 ~ F321 (F323)	: Dlx fun. assignment Configure DIx for the desired state	75 : Cleaning the pump	

Param.	Display / Use	Options/Range	Def.
FB31	: Run time cleaning Operation time	1 ~ 3000 seconds	30 sec.
FB32	: PAUSE Time cleaning Pause time	1 ~ 3000 seconds	30 sec.

The auxiliary parameters for this mode that are set in [7.- Pump Control Menu: Parameter list: Control regulation](#) are indicated below:

Param.	Display / Use	Options/Range	Def.
FB46	: Accel.To freq.Depart. Acceleration time from 0Hz to the starting frequency	0,0 ~ 100,0 seconds	0,0 sec.
FB47	: Decel. Freq.Depart. Deceleration time from starting frequency to 0Hz	0,0 ~ 100,0 seconds	0,0 sec.











4.2.c.- MANUAL / AUTOMATIC control

It may be necessary to manually use the pump or groups of pumps of the installation. The selection of the control method is carried out by an external switch that acts on the **DIx** inputs that have been defined for it.

Assign functions to digital inputs:

Param.	Display / Use	Options/Range	Def.
F316 ~ F321 (F323)	 : Dlx fun. assignment Configure DIx for the desired state	61: Start/Stop by external input 46 : MANUAL Operation mode Operate with manual SP 47 : AUTO operation mode Operate with automatic SP	

Configure the parameters for when the manual control over the pump(s) is selected: :

Param.	Display / Use	Options/Range	Def.
FB29	 : Activate MANUAL/AUTO Manual/Auto function control	0 : Disabled 1 : Enabled	0
FB10	 : Press. setpoint man. Desired SP for when the manual control is selected	FB13 ~ FB15  NOTE: Bar is the default unit; it can be changed in FA34 .	5,00 Bar
FB11	 : Sleep freq. man. Sleep frequency for when the manual control is selected	F112 ~ F111	5,00 Hz
FB12	 : Sleep delay man. Delay in sleep for when the manual control is selected	0,0 ~ 500,0 seconds	15,0 sec.
FB13	 : Restart press. man. Frequency to wake up when manual control is selected	0,0 ~ FB10  NOTE: Bar is the default unit; it can be changed in FA34 .	0,00 Bar
FB14	 : Restart delay man. Delay in awakening for when the manual control is selected	0,0 ~ 3000,0 seconds	3,0 sec.
FB15	 : Pressur up-limit man. Up-limit pressure for operating alarm with manual control	FB10 ~ FA50  NOTE: Bar is the default unit; it can be changed in FA34 .	10,00 Bar



NOTE!! There must be an input signal, either **MANUAL** or **AUTO** for starting the system when the **START** input is activated.

In *simple pump* mode or *pump regulated with fixed pumps* mode operating, the installation does not have any special complexity. The pumps are stopped if S1 is switched off or S2 is set to 0, and it operates with *AUTO* or *MANUAL* pressure as ordered with S2.

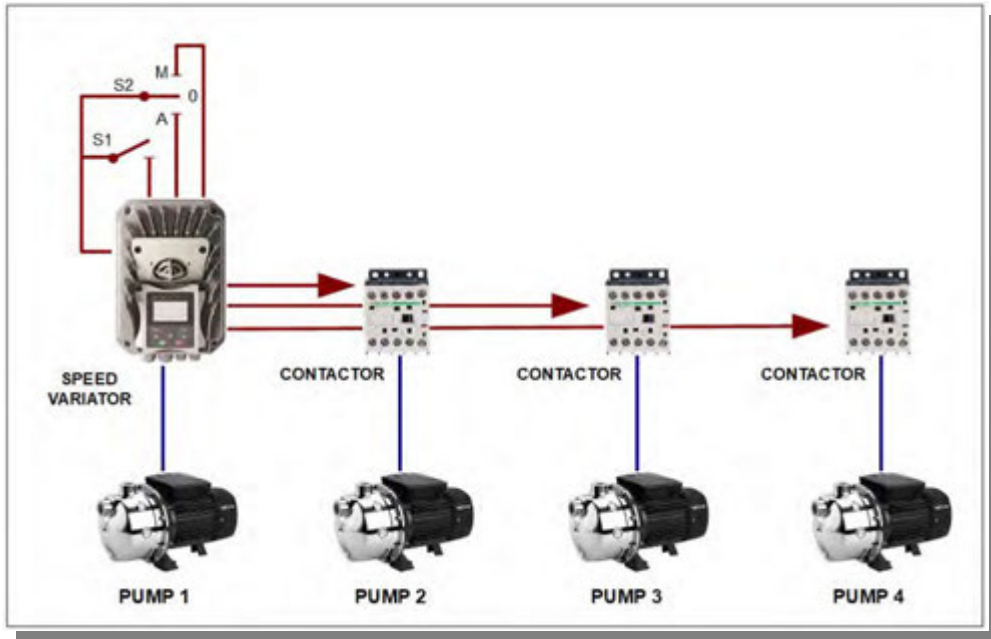

Example of wiring for four pumps, in regulated + fixed mode and *MANUAL/AUTO* function

S1 = Cut-off switch for *START/STOP* signal / S2 = Switch with neutral point for *MANUAL-0-AUTO*

In the *all regulated* mode, with or without alternating *Master*, it is the responsibility of the installer to make the correct wiring so that when the alternation is made, the next logic pump that must enter has the run signal and is in *AUTO*.

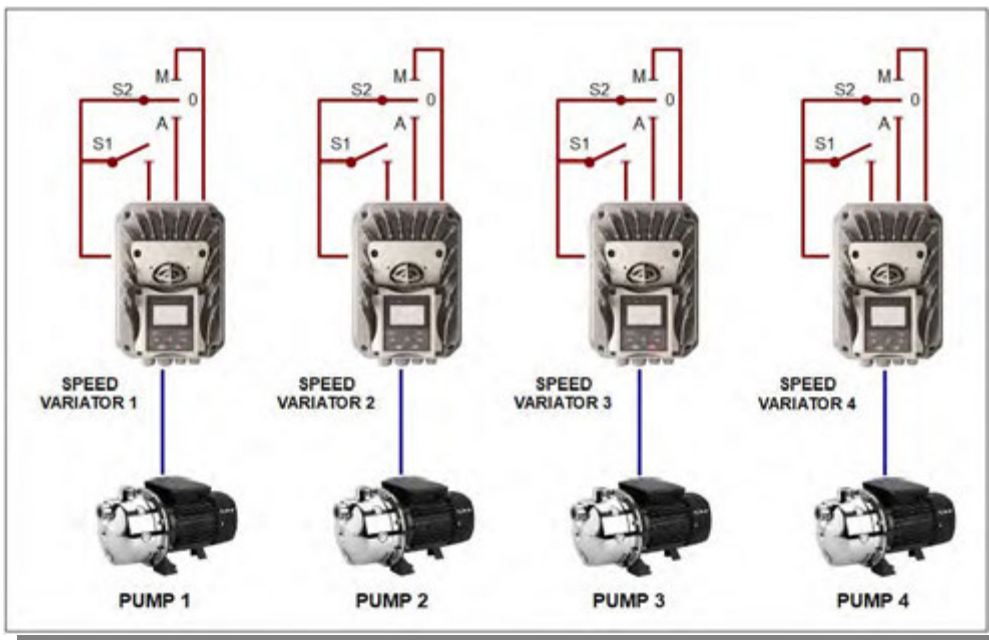

Example of wiring for four pumps in a multimaster group with alternation and *MANUAL/AUTO* function

S1 = Cut-off switch for *START/STOP* signal / S2 = Switch with neutral point for *MANUAL-0-AUTO*

S1 activates the pump in the pressure group, but if S2 is in position 0, it will not start.

The pumps that have S2 in *AUTO* will enter in the *PID* regulation to maintain the pressure in the installation, they will be part of the support pumps, if the *Master* can not maintain *PV* in the *SP* command, and will also become a *Master* when the alternation happens (because of operation of the *Master* or by falling asleep, depending on how it has been parameterized).

Pumps with S2 in *MANUAL* will not be part of the automatic regulation pressure group, and can be started and stopped manually by activating or deactivating S1. It is also always possible to leave S1 activated and start the pump and stop it by manually activating and deactivating S2 in the *MANUAL* position.

4.2.d.- Anti-rust/Anti-freeze

Occasionally, due to the environment of the installation or the working conditions to which the pump is subjected, it must be possible to have the opportunity to periodically make small starts to keep the pump in working condition after very long stops, which could end up blocking the pump shaft due to rust or ice.

If this function is activated, this maintenance function is allowed.

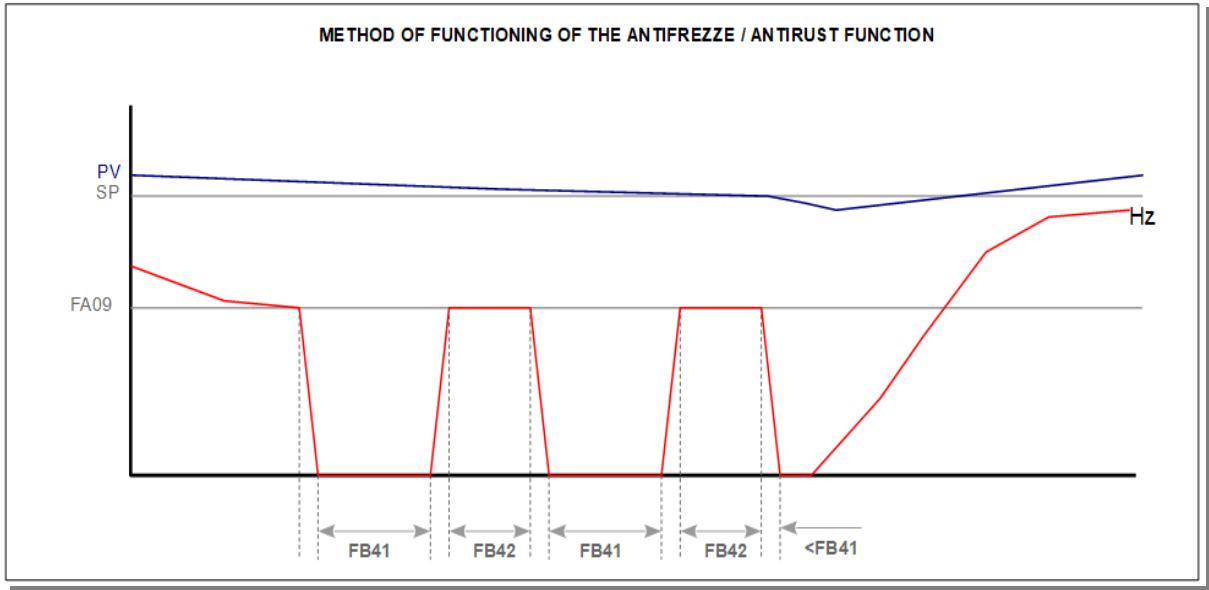





Diagram of operation of the Anti-rust / Anti-freeze control

The special parameters are indicated below.

Param.	Display / Use	Options/Range	Def.
FB40	 : Antifreeze/Antisludge Enable Antirust / Anti-freeze	0 : Disabled 1 : Enabled	0
FB41	 : STOPtimeAntifr/sludge Pause time	1,0 ~ 3000,0 seconds	60,0 sec.
FB42	 : RUNtimeAntifr/sludge Activation time	1,0 ~ 3000,0 seconds	60,0 sec.

4.2.e.- Timer

For irrigation systems, it is important to be able to program the turning on and off of the irrigation system according to hourly needs of the day or daily needs of the week or, in a special way, for having a certain pressure between two time slots and other pressures outside of them.



<i>Param.</i>	<i>Display / Use</i>	<i>Options/Range</i>	<i>Def.</i>
FD00	 : year Parameterization of the clock : Year	2018 ~ 9999	--
FD01	 : month Parameterization of the clock : Month	1 ~ 12	--
FD02	 : day Parameterization of the clock : Day	1 ~ 31	--
FD03	 : week Parameterization of the clock : Weekday	1 ~ 7	--
FD04	 : hours Parameterization of the clock : Hour	0 ~ 23	--
FD05	 : minutes Parameterization of the clock : Minute	0 ~ 59	--
FD06	 : seconds Parameterization of the clock : Second	0 ~ 59	--
FD07	 : Multi day program Multi-day program	0 : Disabled 1 : Enabled	0
FD08	 : Weekend program Weekend program	0 : Disabled 1 : Enabled	0
FD09	 : Daily program Daily program	0 : Disabled 1 : Enabled	0
FD10 ~ FD31	 : START Day x Star day x (month. day) FD13, FD16, FD19, FD22, FD25, FD28, FD31	01.01 ~ 12.31	01.01
FD11 ~ FD32	 : STOP Day x End day x (month. day) FD14, FD17, FD20, FD23, FD26, FD29, FD32	01.01 ~ 12.31	01.01
FD12 ~ FD33	 : Pressure Day x Day x pressure (%) FD15, FD18, FD21, FD24, FD27, FD30, FD33	FA05 ~ FA03	0
FD34 ~ FD48	 : START x Weekend Start weekend x	00.00 ~ 23.59	0.00
FD35 ~ FD49	 : STOP x Weekend End of the weekend x	00.00 ~ 23.59	0.00
FD36 ~ FD50	 : Pressure x Weekend Weekend pressure x (%)	FA05 ~ FA03	0.0
FD58 ~ FD97	 : START x Day program Daily start x	00.00 ~ 23.59	0.00
FD59 ~ FD98	 : STOP 1 Day program Daily end x	00.00 ~ 23.59	0.00

<i>Param.</i>	<i>Display / Use</i>	<i>Options/Range</i>	<i>Def.</i>
FD60 ~ FD99	 : Press. 1 Day program Daily pressure x (%)	FA05 ~ FA03	0.0

	<p><u>NOTE!!</u> Consult the EURA Service-Center to know which models and versions of drives have the RTC in order to use the timer.</p>
---	---

4.2.f.- Solar/well pump autotuning

This function allows to detect, automatically, the exact frequency in which the pump does not pump the water, and therefore the frequency in which the anti-return valve acts. This is very important for the correct use of the resources of the pumping system, without wasting energy and inadequate heating in the pump. The frequency where the over-effort of the pump is detected is stored in the minimum working frequency variable, to make the pump falls asleep (**FA09**).



<i>Param.</i>	<i>Display / Use</i>	<i>Options/Range</i>	<i>Def.</i>
FB00	 : Pump autotuning Activation of the system to perform self-calibration (autotuning) of the pump.	0 : Disabled 1 : Enabled	0
FB01	 : Pump autotuning step Time of permanence in the step of the self-calibration of the pump.	0,1 ~ 5,0 seconds	1,0 sec.
FB02	 : Pump autotuning curr. Current increase for the autotuning step.	0,1 ~ F803	0,1 A

4.2.g.- Anti-return valve control

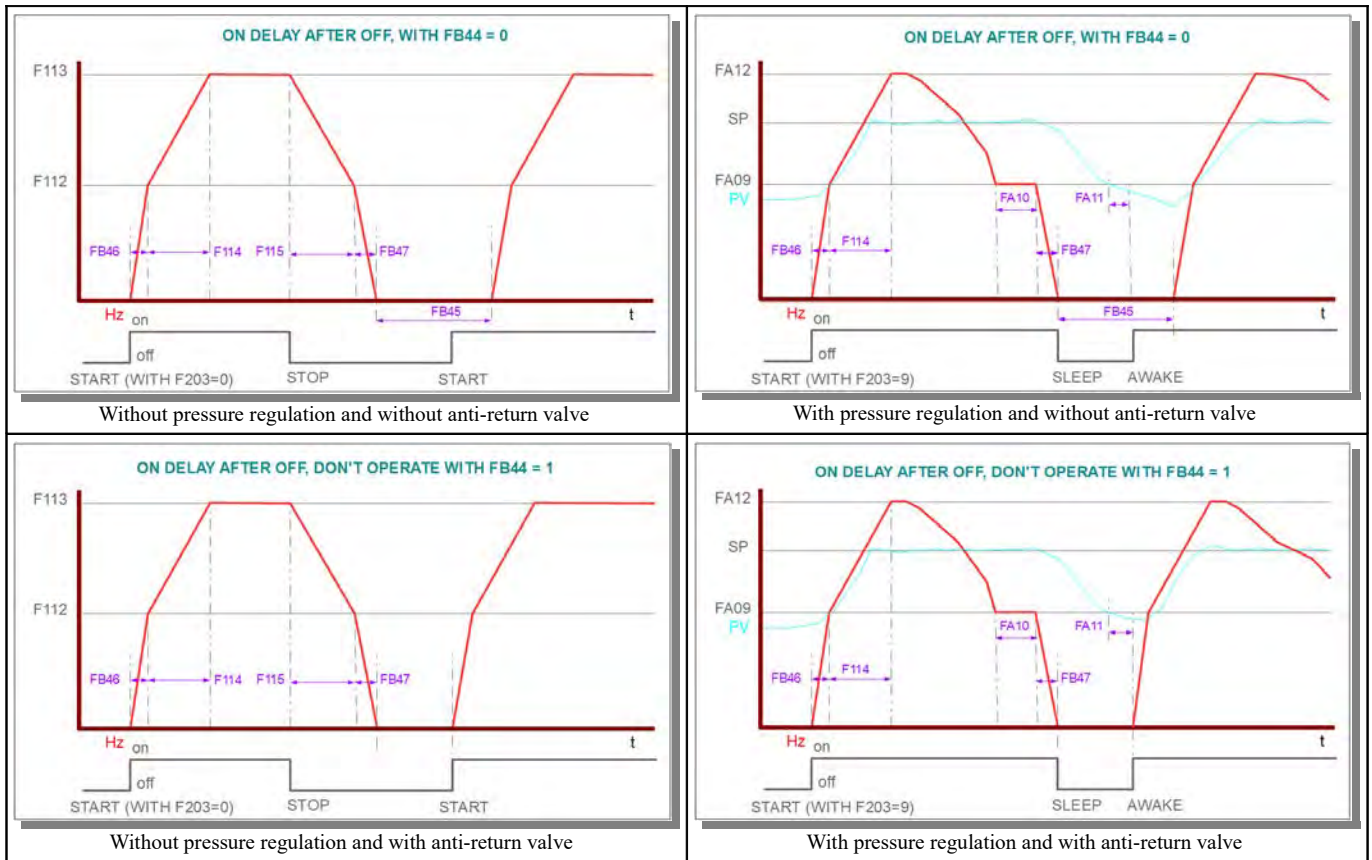
This control affects the pumping operation, when the chosen mode is for well pumps or solar well pumps. If a non-return valve is not installed, it is necessary to wait until the end of the discharge of the water column in the outlet pipe before restarting the pump after stopping it. This is because the pump falls asleep in the extraction mode with pressure control, or has stopped in the manual control mode.



The parameters that control this function are the following:

Param.	Display / Use	Options/Range	Def.
FB44	 : Valve installed Indicate if a anti-return valve is installed at the outlet of your well/solar well pump	0 : Disabled 1 : Enabled	0
FB45	 : ON delay after OFF Time to wait before a new start/wake order after a stop/sleep	0 : Disabled 1 ~ 99 Enabled (minutes)	3 min.

4.2.h.- Flow meter

In irrigation systems, it is often necessary to count the water flow used in each irrigation area. Therefore, a simple solution to this need is offered.

A digital input to count the pulses of the flow meter and a digital input to reset the counter are available. It also offers the option to predetermine a digital output for an external activation or deactivation when reaching a value, or between a previous value and a final value.

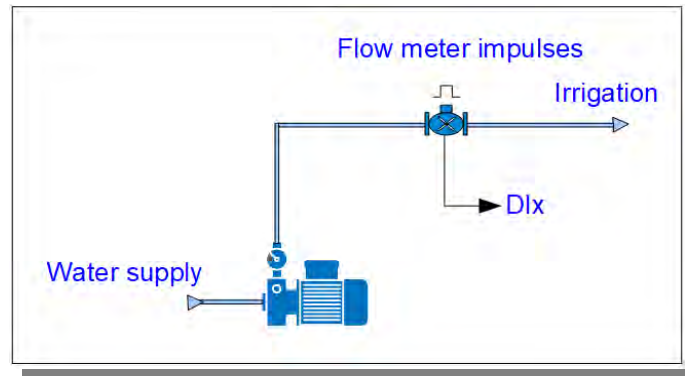

Assign functions to digital inputs in [5.- Pump Control Menu: Parameter list: I / O Configuration](#)



Param.	Display / Use	Options/Range	Def.
F316 ~ F321 (F323)	: Dlx fun. assignment Configure <i>Dlx</i> for the desired states	22: Counter entry 23: Counter reset	
F300	: Rel. func. assignment Configuration of the <i>ROI</i> output relay	8 : Counter value An impulse is generated in the output when reaching the final value of the counter.	1
F301	: DO1 func. assignment Configuration of the output transistor <i>DO1</i>	9 : Intermediate counter in the defined range The output is activated when the value is reached intermediate and it is deactivated in the final value of counter.	14
F302	: DO2 func. assignment Configuration of output relay/transistor <i>RO2/DO2</i>		5

Configure parameters in [7.- Pump Control Menu: Parameter list: Control regulation](#) to be able to visualize the value of the counter while the converter is running and stopped.

Param.	Display / Use	Options/Range	Def.
F131	: Displayvalve-START Display: Selection of the operating parameters to be displayed on the <u>second line</u> of the auxiliary screen during the " <i>ON</i> " status (motor-running)	Add 64: Counter to the value that appears in this parameter.	15
F132	: Displayvalve-STOP Display: Selection of the operating parameters to be displayed on the <u>second line</u> of the auxiliary screen during the " <i>STOP</i> " state (motor stopped)	Add 32: Counter to the value that appears in this parameter.	6

	The counter is displayed on the auxiliary display screen. To access, press the [FUN] key. When the inverter is stopped, the [<<<] key can be used to toggle the display of the values indicated in function F132 . When the inverter is running, the [<<<] key can be used to toggle the display of the values indicated in function F131 .
--	---

Configure the particular parameters for this function.



<i>Param.</i>	<i>Display / Use</i>	<i>Options/Range</i>	<i>Def.</i>
F313	 : Counter input divider Divider for impulse input	1 ~ 65000	1
F314	 : Counter final value Final value of the counter	F315 ~ 65000	1000
F315	 : Count. interm. val. Intermediate value of the counter	1 ~ F315	500

4.2.i.- User macros

Sometimes different configurations must be used for the same pump, for example because it is used in different facilities, under different working and installation conditions.

For this reason, **EURA DRIVES** allows you to store up to two particular configurations in user memories.

Using the two parameters indicated in the following table, It is possible to store the active parameters in any of the user memories, or recover one of those memories to overwrite the active parameters.

<i>Param.</i>	<i>Display / Use</i>	<i>Options/Range</i>	<i>Def.</i>
F135	 : User default SAVE User macros	0 : Disabled 1 : User macros 1 2 : User macros 2	
F160	 : Default RESET Recovery of values	0 : Disabled 1 : Recover the factory setting 21 : Recover user macros 1 22 : Recover user macros 2	

4.3.- Control modes

There are several control methods defined in the pumping system, which are not present in the menu structure, mainly because they can be used for practically all regulation modes.

4.3.a.- SP Adjustable by impulses of DI inputs

When the pumping system is managed by an external **PLC**, it is possible to modify the **SP** setting by pulses recorded in two digital inputs.

Simply configure an input whose **PULSO** will increase the **SP** and configure an input whose **PULSE** will decrease the **SP**.

Param.	Display / Use	Options/Range	Def.
F316 ~ F321 (F323)	 : Dlx fun. assignment Configure DIx for the desired states	78 : Increase SP value 72 : Decrease SP value See note (a) of this paragraph	See paragraph 5



NOTE (a) : The increase and decrease will always be:
0,1 units in the values defined by **FA34** that have a decimal,
1 unit in the values defined by **FA34** that are integers.

4.3.b.- Multiple SP

Sometimes you may have the need to have several **SP**, for example to determine different irrigation pressures depending on the area to be irrigated.



There are three additional **SP**, which with the main **SP**, makes it possible to have 4 different **SP**, to use them conveniently and select them through external inputs.

The function assignment values to the digital inputs are the following:

Param.	Display / Use	Options/Range	Def.
F316 ~ F321 (F323)	 : Dlx fun. assignment Configure DIx for the desired states	44: SP1 Bit 1 selection for remote setpoint 45: SP2 Bit 2 selection for remote setpoint (see table below)	









SP1	SP2	Active SP	Parameter
--	--	The main SP is active (SP 1)	FA04
ON	--	The auxiliary SP 1 is active (SP 2)	FA86
--	ON	The auxiliary SP 2 is active (SP 3)	FA87
ON	ON	The auxiliary SP 3 is active (SP 4)	FA88













The following parameter is used to compensate for measurement differences (excessively remote sensor, contrasted measurement differences, etc ...)

Param.	Display / Use	Options/Range	Def.
FA45	 : Deadband comp. Dead band compensation	 The range and number of decimals varies according to the unit of measure selected in FA34.	

5.- Pump Control Menu: Parameter list: I / O Configuration

The parameters in **CYAN** have the extended information of their use in the corresponding converter technical manual. The parameters in **ITALIC** can not be changed with the converter running.





<i>Param.</i>	<i>Display / Use</i>	<i>Options/Range</i>	<i>Def.</i>
F300	 : Rel. func. assignment Configuration of the RO1 output relay	0: No function 1: Variable error 2: Frequency limit 1 3: Frequency limit 2 4: Disabled converter 5: Converter START-1 6: DC brake 7: Ramp selection 2 8: Counter value 9: Intermediate counter in the defined range	1
F301	 : DO1 func. assignment Configuration of the output transistor DO1	10: Overloaded converter 11: Overloaded motor 12: Ramp temporarily stopped 13: Converter OK 14: Converter START - 2 15: Setpoint frequency reached 16: Overtemperature alarm 17: Current limit 18: Interruption of the analog signal 19: Lack of water 20: Pre-warning of lack of water	14
F302	 : DO2 func. assignment Configuration of output relay/transistor RO2/DO2	21: Control Modbus 2005H 22: Modbus Control 2006H 23: Modbus Control 2007H 24-29: Reserved 30: RUN Secondary Pump 31: RUN Main Pump 32: Pressure alarm 42: Reserved 43: MODBUS Timeout 2	5
F316	 : DI1 func. assignment Function assignment for DI1 From factory 11 (JOG-forward)	0: No function 1: START function 2: STOP function	11
F317	 : DI2 func. assignment Function assignment for DI2 From factory 9 (EMERGENCY-STDI EXT.)	3: Fixed Frequency K1 4: Fixed Frequency K2 5: Fixed Frequency K3 6: Fixed Frequency K4	9
F318	 : DI3 func. assignment Function assignment for DI3 From factory 15 (TERMINAL "FWD")	7: RESET 8: STOP-Disabled 9: STOP EMERGENCY 10: RAMPSTOP	15
F319	 : DI4 func. assignment Function assignment for DI4 From factory 16 (TERMINAL "REV")	11: JOG Direct 12: JOG Inirect 13: Motorpotentiometer + 14: Motorpotentiometer - 15: Terminal "FWD"	16
F320	 : DI5 func. assignment Function assignment for DI5 From factory (RESET)	16: Terminal "REV" 17: Terminal "X" 18: BIT1 Selection of ramp settings	7

Param.	Display / Use	Options/Range	Def.
F321	 : DI6 func. assignment Asignación de función para DI6 DFrom factory (STOP-DISABLE)	19: Reserved 20: M / n (Speed/Pair) 21: Setpoint supply 22: Counter entry 23: Counter reset 24-29: Reserved 30: Lack of water 31: Water OK 32: Pressure FIRE 33: FIRE MODE	8
F322	 : DI7 func. assignment Asignación de función para DI1 From factory (START)  Solo en EP66 y E2000 >22kW	34: Selection of Ramp settings BIT2 35: Parameter Setting (BIT1) 36: Parameter Setting (BIT2) 37: NTC / NO 38: PTC / NC 49: PID-STOP 48: Internal PID	1
F323	 : DI8 func. assignment Asignación de función para DI8 From factory (STOP)  Solo en EP66 y E2000 >22kW	51: Alternative motor 53: Watchdog 60: RS485 Timeout reset 61: START / STOP 71: Make filling 72: Emptying 73: HIGH level entry 74: LOW level entry 75: Carry out pump cleaning 78: Increase setpoint (+1 or +0.1 according to unit) 79: Decrease setpoint (-1 or -0.1 according to unit)	2
F400	 : AI1 Lower limit Low range limit (V) for AI1	0.00V... F402  If the sensor is 4...20mA, F400 =2.00 and observe the positioning of the switches on the control board.	0,00V
F406	 : AI2 Lower limit Low range limit (V) for AI2	0.00V... F408  If the sensor is...20mA, F406 =2.00 and observe the positioning of the switches on the control board.	0,00V
F431	 : AO1 function assign Assignment of operational parameters in AO1	0: Motor Frequency 1: Motor Current (For 2xI-n) 2: Motor Voltage (For 230/400V)	0
F432	 : AO2 function assign Assignment of operational parameters in AO2	3: AI1 4: AI2 5: Input Pulses 6: Par- for Nm 7: Via MODBUS 8: Target frequency 9: Calculated speed 10: Par (motoric)	1
F438	 : AI1 U/I selection Type of entry for AI1	0: Voltage mode 1: Current mode	0
F439	 : AI2 U/I selection Type of entry for AI2	0: Voltage mode 1: Current mode	1

	About F300, F301 and F302 Hardware outputs in EM30 : 1 = Relay RO1 , 2 = Transistor DO1 , 3 = Relay RO2 (all sizes) Hardware outputs on EP66 : 1 = Relay RO1 , 2 = Transistor DO1 (<15kW) Hardware outputs on EP66 : 1 = Relay RO1 , 2 = Transistor DO1 , 3 = Transistor DO2 (18.5 ~ 90kW) Hardware outputs in E2000 : 1 = Relay RO1 , 2 = Transistor DO1 (<30kW) Hardware outputs in E2000 : 1 = Relay RO1 , 2 = Transistor DO1 , 3 = Transistor DO2 (30 ~ 400kW)
---	--

6.- Pump Control Menu: Parameter List: PID Configuration



The parameters in **CYAN** have the extended information of their use in the corresponding converter technical manual. The parameters in **ITALIC** can not be changed with the converter running.

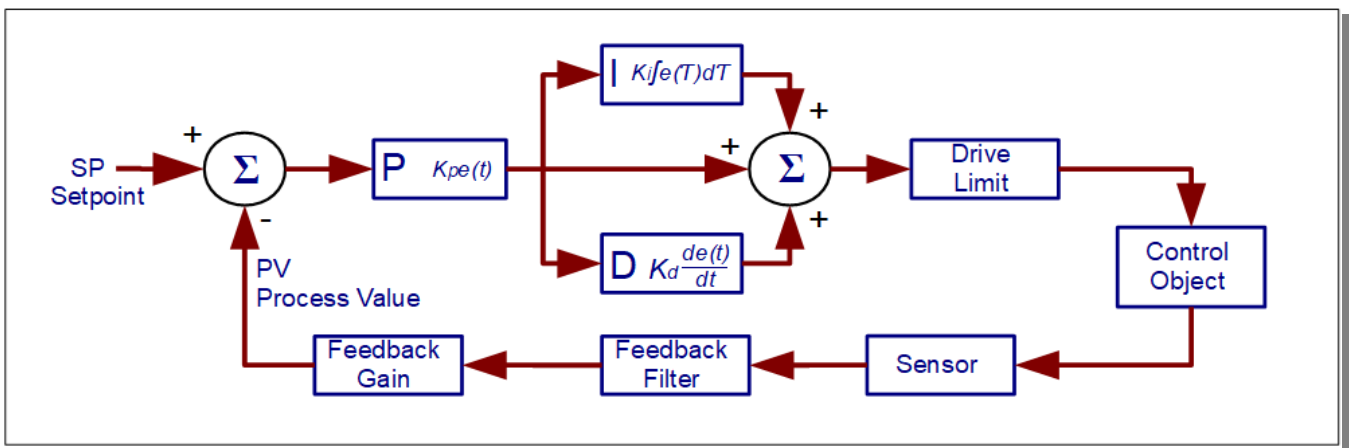















Param.	Display / Use	Options/Range	Def.
FA00	 : PID Controller mode Controller settings	0: Simple pumping control 5: Regulated + fixed mode (WITHOUT <i>Slave</i> rotation) 6: Regulated + fixed mode (rotation of <i>Slaves</i> by running time) 7: Regulated + fixed mode (rotation of <i>Slaves</i> when the <i>Master</i> falls asleep) 10: Multimaster fixed pumps 11: Multimaster <i>Master</i> rotation by time 12: Multimaster <i>Master</i> rotation at sleep	0
FA01	 : PID setpoint channel <i>PID</i> set point	0: Internal reference (value in FA04) 1: <i>AI1</i> analog input 2: <i>AI2</i> analog input 3: <i>AI3</i> (Keyboard potentiometer) 4: Frequency (pulse input)	0
FA02	 : PID deed-back channel <i>PID</i> feedback	1: <i>AI1</i> analog input 2: <i>AI2</i> analog input 3: Frequency (pulse input) 4: Reserved 5: Motor current 6: Output power 7: Par output	1
FA34	 : Measurement unit Pressure unit/measure unit	0 : % 1 : Mpa 2 : Bar 3 : psi 4 : cm 5 : M 6 : cm/Sec 7 : M/Sec 8 : °C	2



























Graphic representation of the *PID* action.

To activate the *PID* action, set **F203** = 9 to [7.- Pump Control Menu: Parameter list: Control regulation](#)

FA04	 : Internal PID setpoint Internal set point value	FA05....FA03	50
FA03	 : Contr. range upp.lim Upper control limit (% of setpoint)	FA04....FA50 See note (1) at the bottom of this table	100 %

Param.	Display / Use	Options/Range	Def.
FA50	 : Main Pressure Range Pressure range of the <u>transmitter of the pressure group</u> See note (b)	See note (a)	
FA06	 : PID polarity POS/NEG PID control polarity	0 : Positive 1 : Negative	1
FA19	 : PID proportional gain Proportional Gain <i>P</i>	0,00...10,00	0.3
FA20	 : PID Integration time Integral Time <i>I</i>	0,1...100,0 seconds	0.3 sec.
FA21	 : PID Differential time Differential Time <i>D</i> (sec.)	0,00...10,00	0,0 sec
FA22	 : PID Sampling rate Time cycle control / scan coefficient (sec.)	0,1...10,0 seconds	0,1 sec.
FA29	 : PID Dead zone Dead band adjustment (% of the set point)	0,0 – 10,0 %	2,0 %
FA45	 : Deadband comp. Dead band compensation	See note (a)	
FA12	 : PID Max. frequency Maximum working frequency in <i>PID</i>	FA09.....F111 (Hz)	50 Hz
FA07	 : Sleep mode enable Automatic sleep mode	0: activated 1: disabled	1
FA84	 : PID sleep mode PID sleep mode	0 : Sleep in FA09 <i>PV</i> is in FA09 during FA10, it falls asleep. 1 : Sleep below FA09 (F112) <i>PV</i> is in FA09 during half the time of FA10, the frequency of the pump goes down to F112 during the other half of the time of FA10 and it falls asleep.	0
FA09	 : Freq. threshold sleep Frequency threshold to activate the sleep function	F112~F111	5,00 Hz
FA10	 : Delay-time sleep Delay for the Sleep function	0...500 seconds	15 sec.
FA11	 : Delay time wake-up Delay for the reactivation of the function Sleeping (sec.)	0...3000 seconds	3.0 sec.
FA05	 : Wake-up pressure Lower control limit (unit of set point)	0.0...FA04	0,0 bar
FA67	 : Wake-up mode Mode in which the pumping system "wakes up"	0 : Restart (wake up) <i>mode 1</i> If FA06=0, Wake up with the <u>absolute pressure</u> marked on FA05 1 : Restart (wake up) <i>mode 2</i> If FA06=0, Wake up with the <u>relative pressure</u> of SP-FA69 If FA06=1, Wake up with the <u>relative pressure</u> of SP+FA68	0
FA68	 : Restart press (+) Pressure (+) restart	See note (a)	2.0

<i>Param.</i>	<i>Display / Use</i>	<i>Options/Range</i>	<i>Def.</i>
FA69	 : Restart press (-) Pressure (-) restart	See note (a)	2.0
FA33	 : M/S STOP mode STOP <i>Master/Slave</i> mode	0: By inertia The converter stops controlling the pump, it stops due to its own inertia 1 : By ramp The converter controls the pump, and stops it with the time ramp defined in F115	
FA55	 : M/S Pump number Pump number in the <i>Master/ Slave</i> chain	0 ~ 14	0
FA56	 : Main sensor fault See note (b)	0 : Deactivated 1 : Error message Aer0	0
FA90	 : In/Out Switchover See note (b)	0 : Deactivated 1 : Activated	0
FA13	 : Auxiliar.Press.Source Origin pressure entry See note (b)	0 : Deactivated 1: AI1 analog input 2: AI2 analog input	0
FA49	 : Auxiliar.Press.Range Input pressure range	See reference manual	
FA91	 : IN up-limit press. See note (b)	FA93~FA49 See note (2) at the bottom of this table	
FA92	 : IN switchover press. See note (b)	FA94~FA49	
FA93	 : Auxiliar.Setpoint See note (b)	FA94~FA91	
FA94	 : Sleep Press.Auxiliar See note (b)	0,0~FA93	
FA95	 : Auxiliar.PID Polarity See note (b)	0 : Positive 1 : Negative	0
FA57	 : Auxiliar.Sensor fault See note (b)	0 : Deactivated 1 : Error message Aer1	0
FA51	 : Press. threshold IN 1 Sensor pressure threshold <i>IN 1</i> (input sensor) See note (b)	FA52~FA49	
FA52	 : Press. threshold IN 2 Sensor pressure threshold <i>IN 2</i> (input sensor) See note (b)	0,0~FA51	
FA53	 : Delay 1 Monitoring time to restart the pump	0,0~60,0 seconds	0,0 sec.
FA54	 : Delay 2 Monitoring time to stop the pump	0,0~60,0 seconds	0,0 sec.
FA86	 : Int. PID setpoint 2 Second <i>SP</i> selectable by entry	FA05~FA03	
FA87	 : Int. PID setpoint 3 Third <i>SP</i> selectable by entry	FA05~FA03	
FA88	 : Int. PID setpoint 4 4th <i>SP</i> selectable by entry	FA05~FA03	

<i>Param.</i>	<i>Display / Use</i>	<i>Options/Range</i>	<i>Def.</i>
FA30	 : Inv. Pump startdelay Delay to start an auxiliary pump in case of need	2,0~999,9 seconds	20,0 sec.
FA31	 : Pump startdelay Delay to start a linked pump in case of need	0,1~999,9 seconds	30,0 sec.
FA32	 : Pump stopdelay Delay to stop a linked pump if it is not necessary (sec.)	0,1~999,9 seconds	30,0 sec.
FA44	 : M/S control mode It establishes the behavior of the <i>Slave</i> with respect to the <i>Master</i> being linked	0: <i>Slave</i> Setpoint = <i>Master</i> Setpoint The <i>Slave</i> operates in a twin way to the <i>Master</i> , regulates his speed at the same time 1: <i>Slave</i> Setpoint = <i>PID</i> setpoint The <i>Slave</i> operates independently to the <i>Master</i> , <i>PID</i> regulates your speed	0
FA99	 : Param. synchronizing It allows to synchronize from a <i>Slave</i> the parameters of regulation and control of the <i>Master</i> (See 3.b.3- Synchronized parameters to know the ones that are synchronized)	0 : Disabled The <i>Slave</i> keeps its own parameters 1 : Activated The <i>Slave</i> copies the parameters of the <i>PID</i> and of the regulation of the <i>Master</i> (* See 3.b.- Automatic synchronization)	0



NOTE(1) : When the pressure reaches the set value, protection is activated. If the converter is running, it will stop, indicating the error "**nP**"

NOTE (2) : When the pressure reaches the set value, protection is activated. If the converter is running, it will stop, indicating the error "**nPI**"













NOTE (a) : The range and number of decimals varies according to the unit of measure selected in **FA34**.





NOTE (b) : The definition "INPUT" and "OUTPUT" for the parameters is specified for the sensors corresponding to the positioning position specified in [1.3.- Pressure empty mode](#).



















To avoid misunderstandings in the other applications, the output sensor is indicated as the MAIN SENSOR and the input sensor is indicated as the AUXILIARY SENSOR





7.- Pump Control Menu: Parameter list: Control regulation

The parameters in **CYAN** have the extended information of their use in the corresponding converter technical manual. The parameters in **ITALIC** can not be changed with the converter running.

Param.	Display / Use	Options/Range	Def.
F106	 : Control algorithm Adjust the Control algorithm as needed.  For pumps, the most usual is 2:V/Hz	0 : Sensorless Vector (SLV) 1 : Reserved 2 : V/Hz mode 3 : Vector (Slip compensation) 6 : Synchronous motor control	2
F112	 : Minimum frequency Minimum work frequency  (Do not confuse with the sleep frequency of pumps)	0.00 - F113 Hz	0,50 Hz
FB46	 : Accel.To freq.Depart. Acceleration time from 0 Hz to start frequency.	0,0~100,0 seconds	0,0 sec.
F114	 : 1. Acceleration ramp Normal acceleration ramp	0.1 – 3000 seconds	5.0 sec.
FB47	 : Decel. Freq.Depart. Deceleration time from starting frequency to 0Hz.	0,0~100,0 seconds	0,0 sec.
F115	 : 1. Deceleration ramp Normal deceleration ramp (sec.)	0.1 – 3000 sec.	5.0 sec.
F138	 : V/Hz Lin. BOOST Linear/quadratic boost curve	1 - 20	According to VAR
F153	 : Carrier frequency Switching frequency PWM of the transistors	0.2 - 7.5 kW : 800 Hz – 16.000 Hz 11 – 15 kW : 800 Hz – 10.000 Hz 18.5 kW – 45 kW : 800 Hz – 6.000 Hz >55kW : 800 Hz – 4.000 Hz	4kHz 3kHz 4kHz 2kHz
F159	 : Random carrier "RANDOM" PWM modulation	0 : PWM constant frequency 1 : "RANDOM" modulated PWM	1
F131	 : Displayvalue-START Display: Selection of the operating parameters to be displayed on the <u>second line</u> of the auxiliary screen during the "ON" status (motor-running)	0: Output frequency/value of param. 1: motor speed (rpm) 2: Motor current 4: Motor voltage 8: DC voltage 16: PID control feedback 32: Heatsink temperature 64: Counter 128: Speed (linear - calculated) 256: PID setpoint 512: Reserved 1024: Reserved 2048: Motor-Power 4096: Motor-Torque 8192: Reserved	0 +1 +2 +4 +8 =15

<i>Param.</i>	<i>Display / Use</i>	<i>Options/Range</i>	<i>Def.</i>
F132	 : Displayvalue-STOP Display: Selection of the operating parameters to be displayed on the <u>second line</u> of the auxiliary screen during the "STOP" state (motor stopped)	0: Frequency set/Param. (Fxxx) 1: Module Jog by keyboard - HF-0 2: Motor speed determined (RPM) 4: DC voltage 8: Feedback of the PID control 16: Heatsink temperature 32: Counter 64: PID setpoint 128: Reserved 256: Reserved 512: Torque control reference 1024: Reserved 2048: Reserved	0 +2 +4 =6
F645	 : Main Display Display: Value to represent in the <u>first line</u> of the auxiliary screen	0: Output frequency 1: RPM 2: RPM setpoint 3: Motor current 4: Motor voltage 5: DC bus voltage 6: PID setpoint (SP) 7: Return PID (PV) 8: Heatsink temperature 9: Counter 10: Calculated speed 11: First frequency reference 12: First frequency 13: Second frequency reference 14: Second frequency 15: Internal setpoint 17: TORQUE 18: TORQUE setpoint 19: Rated power of the converter 20: Output power 21: State of the converter 22: Monitor terminals DI 23: Monitor terminals DO 24: Preset speeds 25: Analog value AI1 26: Analog value AI2 29: Pulse input frequency 30: Pulse output frequency 31: Analog value AO1 32: Analog value AO2 33: "ON" hours	0
F202	 : Rotation direction It makes possible to invert the direction of rotation of the pump	0 : Direct rotation 1 : Inverse rotation	0
F203	 : Primary setpoint X Possible reference input ways of the first speed "X"  For all pumping operation with pressure sensor F203=9 : PID control (except "Level control" and regulation by keyboard potentiometer)	0 : Internal reference (F113) with memory 1: AI1 analog input 2: AI2 analog input 3: Reserved 4: Fixed frequencies, by terminals (Digital inputs) 5: Same as 0, (F113) but without memory 6: Keyboard Potentiometer (AI3) 7: Reserved 8: Reserved 9: PID control 10: MODBUS	0

Param.	Display / Use	Options/Range	Def.
F204	 : Secondary setpoint Y Possible reference input ways of the second speed "Y"  It can be combined with F203, using the selected way in F207	0: Internal reference (F155) with memory 1: AI1 analog input 2: AI2 analog input 3: Reserved 4: Fixed frequencies, by terminals (Digital inputs) 5: Same as 0, (F155) but without memory 6: PID control 7: Keyboard Potentiometer (AI3)	0
F207	 : Speed setpoint source Output frequency as a combination of the setpoints of the first ("X") and the second ("Y") speed.	0: X, Only the first setpoint is used 1: X + Y Sum of the two slogans 2: X or Y (selection by terminals) 3: X or X + Y (selection by terminals) 4: X (Fixed Frequencies) and Y (Analog) combined 5: X-Y Difference between the two setpoint values 6: X + Y (F206-50%) * (value defined in F205)	0
F208	 : 2/3 Wire control mode Start/stop by two, three cables	0: Disabled 1: Two cables, type 1 (static) 2: Two cables, type 2 (static) 3: Three wires, type 1 (Pulse / Pushbutton - dynamic) 4: Three cables, type 2 (Pulse / Pushbutton - dynamic) 5: Pulse / Pushbutton - dynamic	0
F213	 : Power-ON Autostart Autostart after a power drop	0: Disabled 1: Activated	0
F215	 : Autostart - delay Autostart delay after power drop	0,1...3000,0 seconds	60,0 sec.
F900	 : Inv. adress assignement Electronic address (unit number) of the converter	1...15  (In operation, if duplicate device numbers are detected, error E001 is signaled)	1
F160	 : Default RESET Reverting the converter to manufacturer values	0 : Normal Operation 1 : Factory Parameters See procedure in: <u>II.d1- Return the converter to its default factory settings</u>	0
F801	 : Motor rated power Rated power on the motor plate (kW)	0.2...1000 kW	
F802	 : Motor rated voltage Rated voltage on the motor plate (V)	1...440 V	
F803	 : Motor rated current Rated current on the motor plate (A)	0.1...6500 A	
F804	 : Pole Nr. (READ-ONLY) Number of poles (p) (only reading !!)	Automatic calculation	
F805	 : Motor rated rpm Rated speed on the motor plate (RPM)	1...30000 U/min	
F806	 : Resist..stator.motor Stator resistance (Ohm)	0.001...65.00 Ohm	
F807	 : Resist.rotor.motor Rotor resistance (Ohm)	0.001...65.00 Ohm	
F808	 : Leakage inductance Leakage inductance (mH)	0.01...650.0 mH	
F809	 : Main inductance Main inductance (mH)	0.1...6500 mH	

<i>Param.</i>	<i>Display / Use</i>	<i>Options/Range</i>	<i>Def.</i>
F810	 : Motor rated frequency Rated motor frequency (Hz)	1.0...300.0 Hz	50,00 Hz
F800	 : AUTOTUNING Mode Measurement of motor data (AUTOTUNING)	0 : AUTOTUNING disabled 1 : START AUTOTUNING dynamic 2 : START AUTOTUNING static See procedure in: II.d2- Motor autotuning	0
FA96	 : Level Control Level control function	0 : Deactivated 1 : Enabled	0
FA33	 : M/S STOP mode Stop mode in the <i>Master/Slave</i> function	0: By inertia 1: By ramp	0

8.- List of alarms

The operation of the pumping system is continuously supervised and in the case of need to report a state, an anomaly, or malfunction, the inverter will do it using the following list of messages:

Display	Definition	Corrective action
:E001	Duplicate device (in F900)	Check the configuration of the chain drives.
2:OC	Overcurrent	Increase the time of Ac./Deac. Check the motor wiring. Check the mechanical system. Reduce the starting torque. Check motor parameters
3:OE	Overvoltage	Check the voltage input. Correct Rated voltage of the converter. Use braking resistors. Increase the deceleration time.
4:PF1	Lack of entry phase	Check network entry.
5:OL1	Overloaded converter	Reduce the power Check the dimensioning of the equipment.
6:LU	Low input voltage Voltage on the <i>DC BUS</i> too low	Check network supply
7:OH	Overheating of the converter	Check environmental working conditions. Check the parameterization Check the drive assembly.
8:OL2	Motor overload	Reduce the load Check the dimensioning of the equipment .
11:ESP	External emergency	Disconnect external emergency condition, emergency button, safety curtain, etc.
12:Err3	Over-current in STOP situation	Visual inspection of the converter and the installation. Contact EURA Service-Center
13:Err2	Autotuning Error	The motor has not rotated freely during the TEST process, leaving the motor on free axle
15:Err4	Current sensor error, there is no current signal on the control board	Visual inspection of the converter. Contact EURA Service-Center
16:OC1	Over current software detected	Increase the time of Ac./Deac. Check the motor wiring. Check the mechanical system. Reduce the starting torque. Check motor parameters.
17:PF0	Balance in output phases	Check motor and wiring.
18:AErr	Interruption of the analog signal	Check the wiring. Review the correct programming of the minimum limit. Check the analog input signal.
19:EP3	Converter with low load or little water	Review of mechanics. Reset the water supply.
20:EP		
20:EP2		
22:nP	Pressure outside limits	Faulty Pump Control Settings. Check water supply.
23:Err5	Error in the PID control	Review incorrect parameterization of the PID
24:SLP	The converter is "asleep"	As a result of the correction of the PID , the operating frequency has been in FA09 during the FA10 time.
25:EP4	Detected dry operation	Check admission circuit to the pump (s). Check that the inlet valves are open. Check that there is water in the inlet pipe.

Display	Definition	Corrective action
32:PCE	Error in the autotuning of the permanent magnet synchronous motor	The motor has not rotated freely during the TEST process, leaving the motor on free axle
35:OH1	Overheated motor	Check the motor .
45:CE	MODBUS out of time	Check MODBUS wiring. Check MODBUS parameterization
47:EEEP	EEPROM error	Contact EURA Service-Center
49:Err6	Watchdog out of time	Check the Watchdog in the assigned digital input
55:SLP1	The converter is "asleep" because of INI (input sensor)	As a result of the correction of the PID , the operating frequency has been in FA09 during the FA10 time.
56:nP1	Pressure outside limits in INI (input sensor)	Faulty Pump Control Settings. Check water supply.
57:EP5	Dry operation detected INI (input sensor)	Check admission circuit to the pump (s). Check that the inlet valves are open. Check that there is water in the inlet pipe.
58:AEr0	Sensor signal IN2 (output sensor) not detected	Check the wiring. Check the sensor connected to IN2 .
67:OC2	Over current software detected	Increase the time of Ac./Deac. Check the motor wiring. Check the mechanical system. Reduce the starting torque. Check motor parameters.
69:EP6	Water leak detected	Check pipes. Check obstruction in the circuit or semi-closed valves.
71:FILL	Failed filling function	Check pipeline installation .
72:ErAT	Error in autotuning well/solar pump	The autotuning has ended without finding the pressure point of the anti-return valve.
73:AEr1	Sensor signal INI (input sensor) not detected	Check the wiring. Check the sensor connected to INI .
74:ErT0	Time control parameters improperly adjusted	Review the parameters of section FDxx .
75:ErJA	Jam detected in the pump	Check that there is no solid body blocking the rotation of the pump.

THESE codes and error messages are specific to the pump control, and do not appear in normal operation.



9.- Observations for optimal running

In the following paragraphs some important recommendations are provided for an optimal adjustment of the installation.

9.1.- The process units and PID

The pump control program can be used in multiple applications; sanitary pumping, irrigation pumping, pumping for fire-fighting, etc ...But its functions, with a little imagination and with the appropriate parameterization, can also be used for applications of ventilation, vacuum, heating or cooling circuits hydraulic, etc ...

All depends on how the **PID** control is parameterized.

Param.	Display / Use	Options/Range	Def.
FA00	 : PID Controller mode Controller settings	0: Simple pumping control 5: Regulated + fixed mode (WITHOUT Slave rotation) 6: Regulated + fixed mode (rotation of Slaves by running time) 7: Regulated + fixed mode (rotation of Slaves when the Master falls asleep) 10: Multimaster fixed pumps 11: Multimaster Master rotation by time 12: Multimaster Master rotation at sleep	0
FA06	 : PID polarity POS/NEG Polarity control PID	0 : Positive 1 : Negative	1

And of the process units that are applied.

Param.	Display / Use	Options/Range	Def.
FA34	 : Measurement unit Pressure unit / unit of measure	0 : % 1 : Mpa 2 : Bar 3 : psi 4 : cm 5 : M 6 : cm/Sec 7 : M/Sec 8 : °C	2

9.2.- Acceleration and deceleration

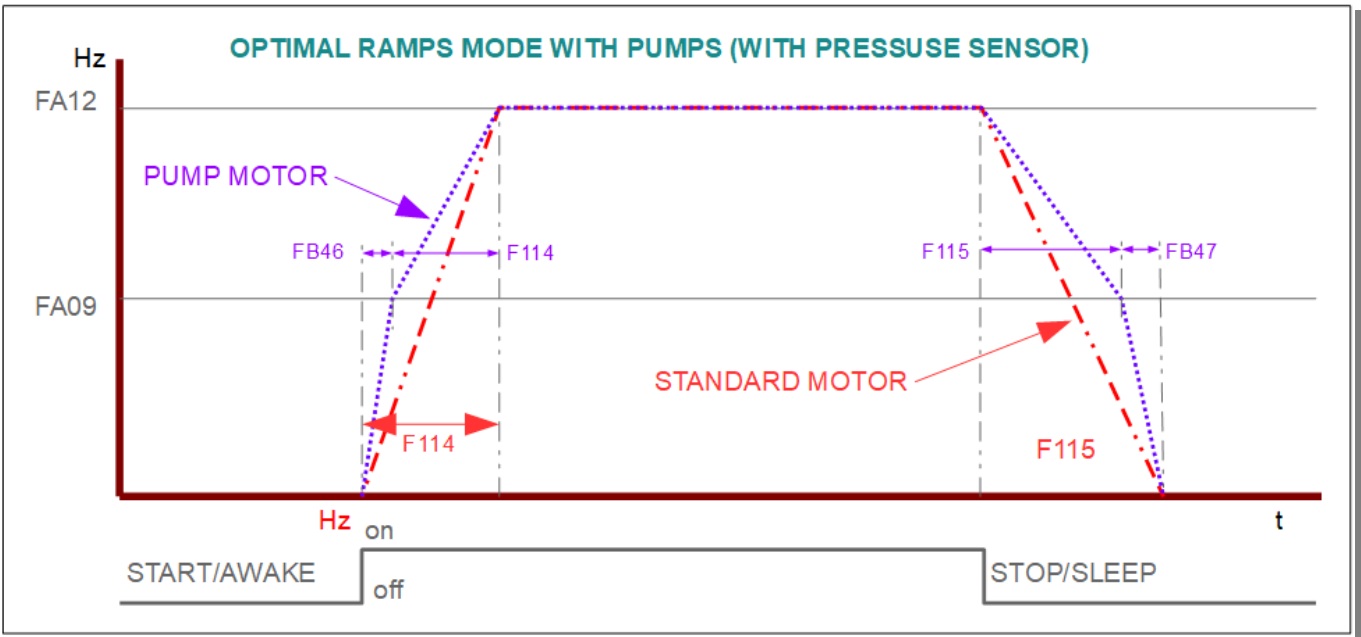
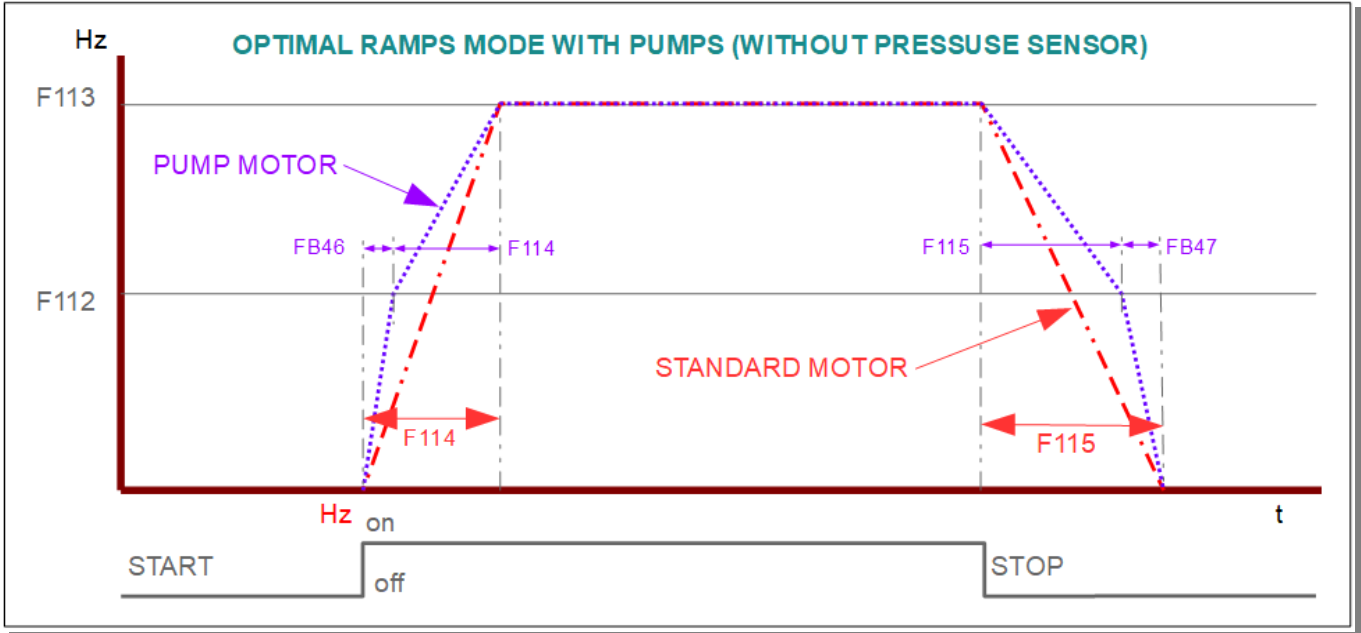

Unlike normal motors, the pumps (especially the wells pumps, regardless of whether their supply is grid or solar) must start the acceleration ramp from the minimum frequency of the pump, set to **F112** if it is not operating with pressure sensor, or from **FA09** if pressure sensor is used, instead of from 0Hz. To protect the pump and the converter itself with excessively abrupt accelerations, special times are established to reach these frequencies. From these frequencies, standard times are used to reach 100% pump speed. Below, there is showed some graphs that represent the operation explained in the previous paragraph are shown.

Below, there is showed some graphs that represent the operation explained in the previous paragraph are shown.





9.3.- Activation of auxiliary pumps (fixed or regulated)

The special parameters to activate a supportive fixed pump to the regulation pump or another regulation pump to the chain of the pressure group are detailed in the following table and graph:

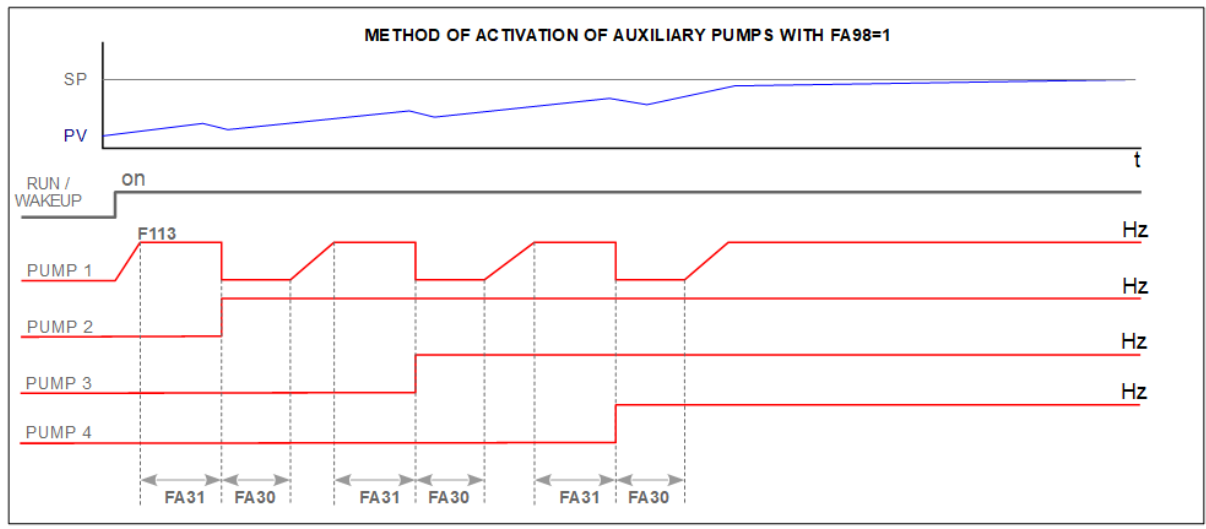
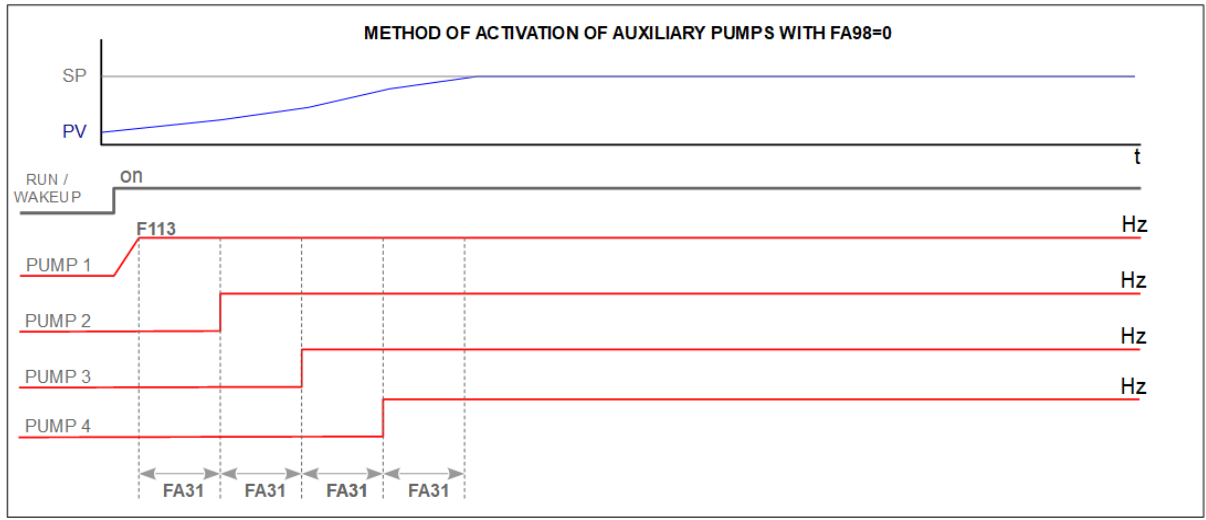
Param.	Display / Use	Options/Range	Def.
FA30	 : Inv. Pump startdelay Delay to start an auxiliary pump in case of need	2,0~999,9 seconds	20,0 sec.
FA31	 : Pump startdelay Delay to start a linked pump in case of need	0,1~999,9 seconds	30,0 sec.
FA98	 : Interchange VFD/POWER Regulated pump stop when a fixed pump start	0 : Disabled 1 : Enabled	1



-  The graphic representation indicates the operation with fixed pumps, starting by contactor or starter. If the auxiliary pumps were regulated pumps, that is controlled by a converter in the pumps chain, the **FA31** time would start counting at the end of the acceleration ramp defined by parameter **F114**, once the converter is at the maximum frequency of the pump (**F113**).
-  The operation of only the first four pumps has been represented. In the "All regulated" mode, the maximum number of linked pumps is **15**.

9.4.- Deactivation of fixed auxiliary pumps

The fixed pumps are deactivated from the pump chain in a simple way, controlled by the following time parameter:

Param.	Display / Use	Options/Range	Def.
FA32	 : Pump stopdelay Delay to stop a pump at the frequency of falling asleep (FA09)	0,1 ~ 999,9 seconds	30,0 sec.

Its behavior is described in the chart below.

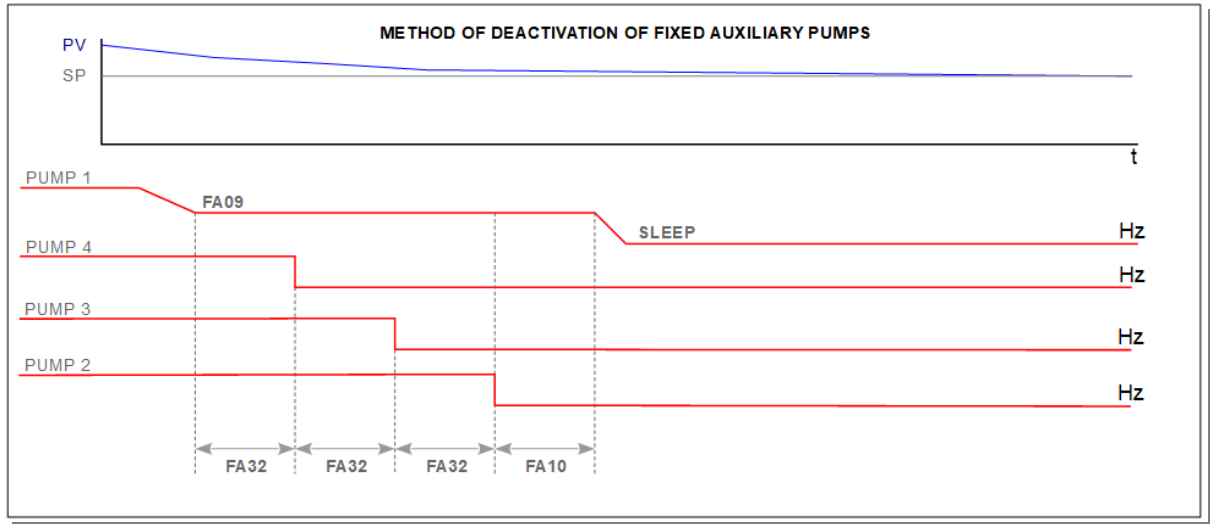

If the **PV** pressure is above the adjusted **SP** the **PID** of the regulated pump will lower its speed to the frequency set for falling **FA09**. From then on the pump will start operating the **FA32** time, which at the end will disconnect the last activated pump, again controlling the **FA32** time to disconnect the antepenultimate. And so on until only the regulated pump is in operation, which will fall asleep after **FA10** time if there is no demand for pressure.

If there is a demand for pressure while the system is in the process of disconnecting pumps, the disconnections will be suspended to reactivate the pump that proceeds.

9.5.- Deactivation of regulated auxiliary pumps

Regulated pumps are deactivated from the chain in two different ways, depending on the setting of the following parameter:

Param.	Display / Use	Options/Range	Def.
FA44	 : M/S control mode It establishes the behavior of the <i>Slave</i> with respect to the <i>Master</i> being linked	0: <i>Slave</i> Setpoint = <i>Master</i> Setpoint The <i>Slave</i> operates in a twin way to the <i>Master</i> , regulates his speed at the same time 1: <i>Slave</i> Setpoint = <i>PID</i> setpoint The <i>Slave</i> operates independently to the <i>Master</i> , <i>PID</i> regulates your speed	0

If **F44 = 0**, and the installation does not demand pressure, the pump control will reduce the speed of **all the pumps at the same time** until the sleeping frequency, and will stop one by one after the **FA32** time, starting with the last *Slave* until ending sleeping the *Master* after **FA10** time. If during the deactivation cycle there was a pressure demand again, the deactivations would be suspended and the *Slaves* would be reactivated with the appropriate sequence.

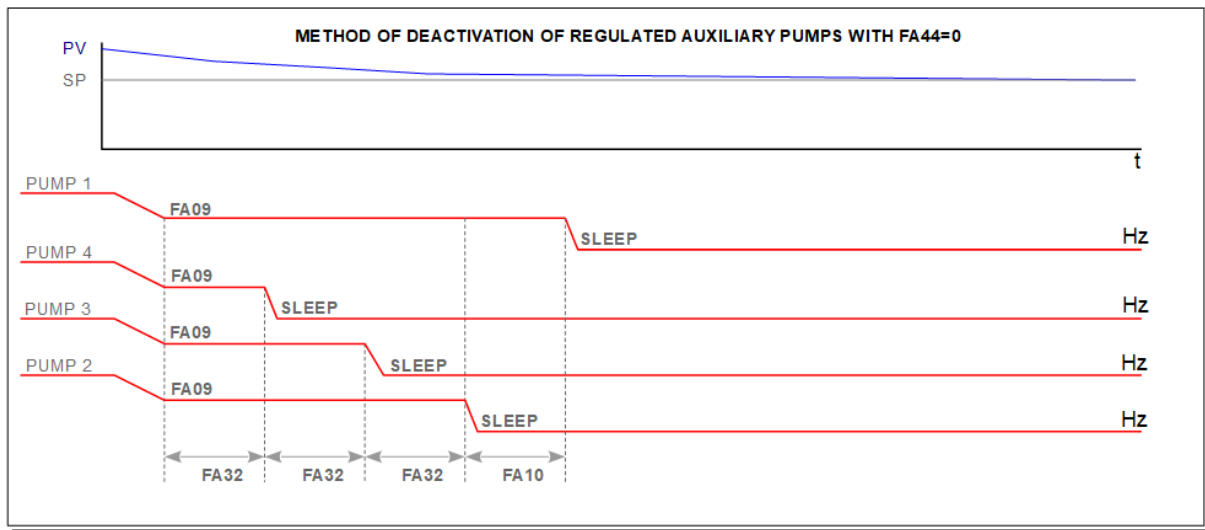

If **F44 = 1**, and the installation does not demand pressure, the pump control will reduce the speed of the last activated *Slave* to the sleeping frequency, and will make it fall asleep after the **FA32** time. Then the pump control will proceed in the same way with the next *Slave*, and so on until sleeping the *Master* after the **FA10** time. If during the deactivation cycle, there was a pressure demand again, the deactivations would be suspended and the *Slaves* would be reactivated with the appropriate sequence.

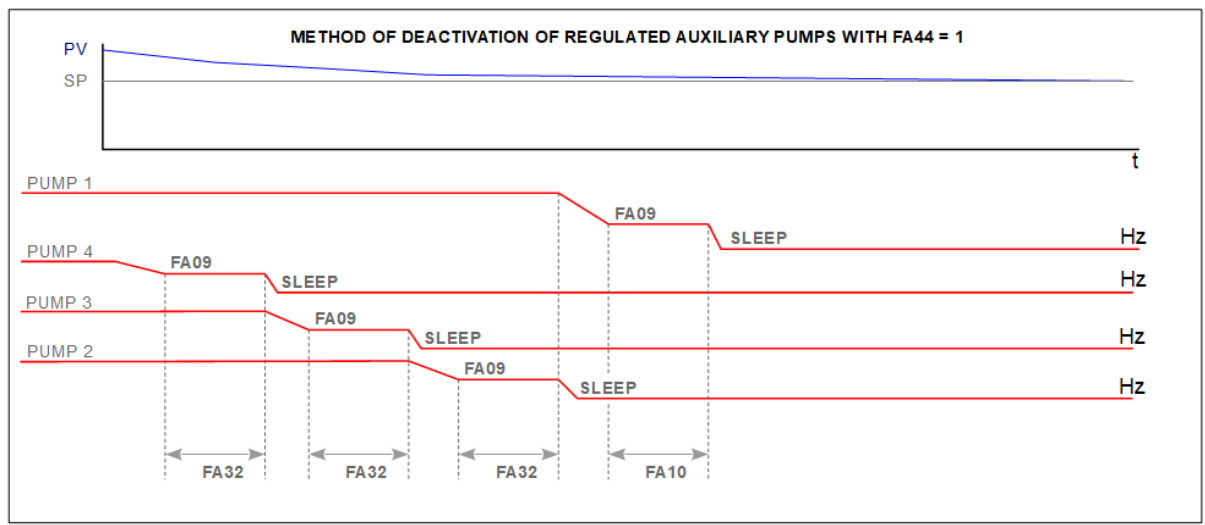



The operation of only the first four pumps has been represented. In the "All regulated" mode, the maximum number of linked pumps is **15**.

9.6.- Automatic restart after voltage failures

It is possible that the pumping system will restart automatically after a power cut.

The parameters that control this function are described below, and they are in the parameter group [7.- Pump Control Menu: Parameter list: Control regulation:](#)

<i>Param.</i>	<i>Display / Use</i>	<i>Options/Range</i>	<i>Def.</i>
F213	 : Power-ON Autostart Autostart after a power drop	0 : Deactivated 1 : Activated	0
F215	 : Autostart - delay Autostart delay after power drop	0,1...3000,0 seconds	60,0 sec.



ATTENTION!!

It is the responsibility of the installer and the service technician to take the necessary precautions so that this action does not entail risks for the people who may be working on the pump, or in the group of pumps, if a power cut occurs.

—

EURA Drives



—
—