

**KCA/KCB092 through 150**

The KCA/KCB 7.5, 8.5, 10 and 12.5 ton (092, 102, 120, 150) packaged cooling units are available in standard cooling efficiency. Optional auxiliary electric heat is factory- or field-installed in KCA/KCB units. Electric heat operates in single or multiple stages depending on the kW input size. 7.5kW through 60kW heat sections are available for the KCA/KCB packaged cooling units.

All KCA/KCB units are designed to accept any of several different energy management thermostat control systems with minimum field wiring. Factory- or field-provided control options connect to the unit with jack plugs. When "plugged in" the controls become an integral part of the unit wiring.

Information contained in this manual is intended for use by qualified service technicians only. All specifications are subject to change. Procedures outlined in this manual are presented as a recommendation only and do not supersede or replace local or state codes.

If the unit must be lifted for service, rig unit by attaching four cables to the holes located in the unit base rail (two holes at each corner). Refer to the installation instructions for the proper rigging technique.



**⚠ WARNING**



**Electric shock hazard. Can cause injury or death. Before attempting to perform any service or maintenance, turn the electrical power to unit OFF at disconnect switch(es). Unit may have multiple power supplies.**

**⚠ WARNING**

**Improper installation, adjustment, alteration, service or maintenance can cause property damage, personal injury or loss of life. Installation and service must be performed by a licensed professional HVAC installer or service agency.**

**⚠ CAUTION**



**Electrostatic discharge can affect electronic components. Take precautions to neutralize electrostatic charge by touching your hand and tools to metal prior to handling the control.**

**⚠ CAUTION**

**Danger of sharp metallic edges. Can cause injury. Take care when servicing unit to avoid accidental contact with sharp edges.**

- Options / Accessories ..... Page 2
- Specifications ..... Page 5
- Blower Data ..... Page 9
- Electrical / Electric Heat Data ..... Page 15
- Electrical Heat Capacities ..... Page 22
- Parts Arrangement ..... Page 23
  - I- Unit Components ..... Page 24
  - II- Placement and Installation ..... Page 35
  - III- Start-Up ..... Page 35
  - IV- Charging ..... Page 36
  - V- System Service Checks ..... Page 45
  - VI- Maintenance ..... Page 45
  - VII- Accessories ..... Page 46
  - VIII-Wiring Diagrams ..... Page 53

## OPTIONS / ACCESSORIES

Item Description	Model Number	Catalog Number	Unit Model No			
			092	102	120	150
<b>COOLING SYSTEM</b>						
Condensate Drain Trap	PVC - C1TRAP20AD2	76W26	X	X	X	X
	Copper - C1TRAP10AD2	76W27	X	X	X	X
Corrosion Protection		Factory	O	O	O	O
Drain Pan Overflow Switch	K1SNSR71AB1-	74W42	X	X	X	X
Efficiency		High	O	O	O	O
		Standard	O	O	O	O
Low Ambient Kit	K1SNSR33B-1	54W16	X	X	X	X
Refrigerant Type		R-410A	O	O	O	O
<b>BLOWER - SUPPLY AIR</b>						
Blower Option	CAV (Constant Air Volume)	Factory	O	O	O	O
	MSAV® (Multi-Stage Air Volume)	Factory	O	O	O	O
Blower Motors	Belt Drive - 2 hp	Factory	O	O	O	O
	Belt Drive - 3 hp	Factory	O	O	O	O
	Belt Drive - 5 hp	Factory	O	O	O	O
VFD Manual Bypass Kit (for MSAV equipped units only)	KVFDB12C-1	90W53	X	X	X	X
Drive Kits	Kit #1 590-890 rpm	Factory	O	O	O	O
See Blower Data Tables for selection	Kit #2 800-1105 rpm	Factory	O	O	O	O
	Kit #3 795-1195 rpm	Factory	O	O	O	O
	Kit #4 730-970 rpm	Factory	O	O	O	O
	Kit #5 940-1200 rpm	Factory	O	O	O	O
	Kit #6 1015-1300 rpm	Factory	O	O	O	O
	Kit #10 900-1135 rpm	Factory	O	O	O	O
	Kit #11 1040-1315 rpm	Factory	O	O	O	O
	Kit #12 1125-1425 rpm	Factory	O	O	O	O
<b>CABINET</b>						
Combination Coil/Hail Guards	C1GARD52B-1	13T05	X	X	X	X
Hinged Access Panels		Factory	O	O	O	O
Horizontal Discharge Kit	K1HECK00B-1	51W25	X	X	X	X
Return Air Adaptor Plate (for LC/LG/LH and TC/TG/TH unit replacement)	C1CONV10B-1	54W96	X	X	X	X
<b>CONTROLS</b>						
Commercial Controls	L Connection® Building Automation System	- - -	X	X	X	X
BACnet®	K0CTRL31B-2	16X71	OX	OX	OX	OX
BACnet® Sensor with Display	K0SNSR01FF1	97W23	X	X	X	X
BACnet® Sensor without Display	K0SNSR00FF1	97W24	X	X	X	X
Novar® 2051	K0CTRL30B-1	96W12	OX	OX	OX	OX
Plenum Cable (75 ft.)	K0MISC00FF1	97W25	X	X	X	X
Smoke Detector - Supply or Return (Power board and one sensor)	C1SNSR44B-2	11K76	X	X	X	X
Smoke Detector - Supply and Return (Power board and two sensors)	C1SNSR43B-2	11K80	X	X	X	X

NOTE - Catalog and model numbers shown are for ordering field installed accessories.

OX - Configure To Order (Factory Installed) or Field Installed

O = Configure To Order (Factory Installed)

X = Field Installed

## OPTIONS / ACCESSORIES

Item Description	Model Number	Catalog Number	Unit Model No			
			092	102	120	150
<b>INDOOR AIR QUALITY</b>						
<b>Air Filters</b>						
Healthy Climate® High Efficiency Air Filters	MERV 8 - C1FLTR15B-1	50W61	X	X	X	X
20 x 25 x 2 (Order 4 per unit)	MERV 13 - C1FLTR40B-1	52W41	X	X	X	X
Replacement Media Filter With Metal Mesh Frame (includes non-pleated filter media)	C1FLTR30B-1-	Y3063	X	X	X	X
<b>Indoor Air Quality (CO<sub>2</sub>) Sensors</b>						
Sensor - Wall-mount, off-white plastic cover with LCD display	C0SNSR50AE1L	77N39	X	X	X	X
Sensor - Wall-mount, off-white plastic cover, no display	C0SNSR52AE1L	87N53	X	X	X	X
Sensor - Black plastic case with LCD display, rated for plenum mounting	C0SNSR51AE1L	87N52	X	X	X	X
Sensor - Wall-mount, black plastic case, no display, rated for plenum mounting	C0MISC19AE1	87N54	X	X	X	X
CO <sub>2</sub> Sensor Duct Mounting Kit - for downflow applications	C0MISC19AE1-	85L43	X	X	X	X
Aspiration Box - for duct mounting non-plenum rated CO <sub>2</sub> sensors (87N53 or 77N39)	C0MISC16AE1-	90N43	X	X	X	X
<b>UVC Germicidal Lamps</b>						
<sup>1</sup> Healthy Climate® UVC Light Kit (208/230v-1ph)	C1UVCL10B-1	54W62	X	X	X	X
<b>ELECTRICAL</b>						
Voltage 60 hz	208/230V - 3 phase	Factory	O	O	O	O
	460V - 3 phase	Factory	O	O	O	O
	575V - 3 phase	Factory	O	O	O	O
Disconnect Switch - See Electrical/Electric Heat tables for selection	80 amp - C1DISC080B-1	54W56	OX	OX	OX	OX
	150 amp - C1DISC150B-1	54W57	OX	OX	OX	OX
GFI Service Outlets	15 amp non-powered, field-wired (208/230V, 460V only) LTAGFIK10/15	74M70	OX	OX	OX	OX
	20 amp non-powered, field-wired (575V only) C1GFICI20FF1	67E01	X	X	X	X
Weatherproof Cover for GFI	C1GFICI99FF1	10C89	X	X	X	X
<b><sup>2</sup> ELECTRIC HEAT</b>						
7.5 kW	208/230V-3ph - C1EHO075B-1Y	56W38	OX	OX		
	460V-3ph - C1EHO075B-1G	56W39	OX	OX		
	575V-3ph - C1EHO075B-1J	56W40	OX	OX		
15 kW	208/230V-3ph - C1EHO150B-1Y	56W41	OX	OX	OX	OX
	460V-3ph - C1EHO150B-1G	56W42	OX	OX	OX	OX
	575V-3ph - C1EHO150B-1J	56W43	OX	OX	OX	OX
22.5 kW	208/230V-3ph - C1EHO225B-1Y	56W44	OX	OX	OX	OX
	460V-3ph - C1EHO225B-1G	56W45	OX	OX	OX	OX
	575V-3ph - C1EHO225B-1J	56W46	OX	OX	OX	OX
30 kW	208/230V-3ph - C1EHO300B-1Y	56W47	OX	OX	OX	OX
	460V-3ph - C1EHO300B-1G	56W48	OX	OX	OX	OX
	575V-3ph - C1EHO300B-1J	56W49	OX	OX	OX	OX
45 kW	208/230V-3ph - C1EHO450B-1Y	56W50	OX	OX	OX	OX
	460V-3ph - C1EHO450B-1G	56W51	OX	OX	OX	OX
	575V-3ph - C1EHO450B-1J	56W52	OX	OX	OX	OX
60 kW	208/230V-3ph - C1EHO600B-1Y	55W02			OX	OX
	460V-3ph - C1EHO600B-1G	55W03			OX	OX
	575V-3ph - C1EHO600B-1J	55W04			OX	OX

<sup>1</sup> Lamps operate on 110-230V single-phase power supply. Step-down transformer may be ordered separately for 460V and 575V units. Alternately, 110V power supply may be used to directly power the UVC ballast(s).

<sup>2</sup> NOTE - Factory installed electric heat is only available with high efficiency models.

NOTE - Catalog and model numbers shown are for ordering field installed accessories.

OX - Configure To Order (Factory Installed) or Field Installed

O = Configure To Order (Factory Installed)

X = Field Installed

## OPTIONS / ACCESSORIES

Item Description	Model Number	Catalog Number	Unit Model No			
			092	102	120	150
<b>ECONOMIZER</b>						
Standard Economizer (Not for Title 24)						
Standard Economizer with Single Temperature Control Downflow or Horizontal Applications - Includes Barometric Relief Dampers and Air Hoods	K1ECON20B-2	13U45	OX	OX	OX	OX
Standard Economizer Controls (Not for Title 24)						
Single Enthalpy Control	C1SNSR64FF1	53W64	OX	OX	OX	OX
Differential Enthalpy Control (order 2)	C1SNSR64FF1	53W64	X	X	X	X
High Performance Economizer (Approved for California Title 24 Building Standards / AMCA Class 1A Certified)						
High Performance Economizer with Single Temperature Control Downflow or Horizontal Applications - Includes Barometric Relief Dampers and Air Hoods	K1ECON22B-2	16X76	OX	OX	OX	OX
High Performance Economizer Controls (Not for Title 24)						
Single Enthalpy Control	C1SNSR60FF1	10Z75	OX	OX	OX	OX
Differential Enthalpy Control (order 2)	C1SNSR60FF1	10Z75	X	X	X	X
Horizontal Low Profile Barometric Relief Dampers With Exhaust Hood						
Horizontal Low Profile Barometric Relief Dampers With Exhaust Hood	LAGEDH03/15	53K04	X	X	X	X
<b>OUTDOOR AIR</b>						
Outdoor Air Dampers With Outdoor Air Hood						
Motorized	C1DAMP20B-1	14G28	OX	OX	OX	OX
Manual	C1DAMP10B-1	14G29	OX	OX	OX	OX
<b>POWER EXHAUST</b>						
Standard Static	208/230V-3ph - K1PWRE10B-1Y	53W44	X	X	X	X
	460V-3ph - K1PWRE10B-1G	53W45	X	X	X	X
	575V-3ph - K1PWRE10B-1J	53W46	X	X	X	X
<b>ROOF CURBS</b>						
Hybrid Roof Curbs, Downflow						
8 in. height	C1CURB70B-1	11F54	X	X	X	X
14 in. height	C1CURB71B-1	11F55	X	X	X	X
18 in. height	C1CURB72B-1	11F56	X	X	X	X
24 in. height	C1CURB73B-1	11F57	X	X	X	X
Adjustable Pitch Curb						
14 in. height	C1CURB55B-1	54W50	X	X	X	X
<b>CEILING DIFFUSERS</b>						
Step-Down - Order one	RTD11-95S	13K61	X			
	RTD11-135S	13K62		X	X	
	RTD11-185S	13K63				X
Flush - Order one	FD11-95S	13K56	X			
	FD11-135S	13K57		X	X	
	FD11-185S	13K58				X
Transitions (Supply and Return) - Order one	C1DIFF30B-1	12X65	X			
	C1DIFF31B-1	12X66		X	X	
	C1DIFF32B-1	12X67				X

NOTE - Catalog and model numbers shown are for ordering field installed accessories.

OX - Configure To Order (Factory Installed) or Field Installed

O = Configure To Order (Factory Installed)

X = Field Installed

SPECIFICATIONS		7.5 TON			
General Data	Nominal Tonnage	7.5 Ton	7.5 Ton	7.5 Ton	7.5 Ton
	Model Number	KCB092S4B	KCA092S4M	KCA092H4B	KCA092H4M
	Efficiency Type	Standard	Standard	High	High
	Blower Type	Constant Air Volume (CAV)	MSAV (Multi-Stage Air Volume)	Constant Air Volume (CAV)	MSAV (Multi-Stage Air Volume)
Cooling Performance	Gross Cooling Capacity - Btuh	87,800	88,200	93,000	93,000
	<sup>1</sup> Net Cooling Capacity - Btuh	86,000	86,000	90,000	90,000
	AHRI Rated Air Flow - cfm	2400	3000	3000	2800
	Total Unit Power - kW	7.7	7.7	7.1	7.1
	<sup>1</sup> EER (Btuh/Watt)	11.2	11.2	12.7	12.7
	<sup>1</sup> IEER (Btuh/Watt)	12.9	13.2	13.0	14.0
AHRI Reference Number		10609475	202088990	202089011	202075431
Refrigerant Charge Furnished	Refrigerant Type	R-410A	R-410A	R-410A	R-410A
	Circuit 1	4 lbs. 0 oz.	4 lbs. 0 oz.	6 lbs. 13 oz.	6 lbs. 13 oz.
	Circuit 2	3 lbs. 6 oz.	3 lbs. 6 oz.	7 lbs. 2 oz.	7 lbs. 2 oz.
Electric Heat Available - See page 3		7.5, 15, 22.5, 30 & 45 KW			
Compressor Type (number)		Scroll (2)	Scroll (2)	Scroll (2)	Scroll (2)
Outdoor Coils	Net face area (total) - sq. ft.	20.9	20.9	28.0	28.0
	Number of rows	1	1	1	1
	Fins per inch	23	23	20	20
Outdoor Coil Fans	Motor - (No.) hp	(2) 1/3	(2) 1/3	(2) 1/3	(2) 1/3
	Motor rpm	1075	1075	1075	1075
	Total Motor watts	740	740	800	800
	Diameter - (No.) in.	(2) 24	(2) 24	(2) 24	(2) 24
	Number of blades	3	3	3	3
	Total Air volume - cfm	8800	8800	8800	8800
Indoor Coils	Net face area (total) - sq. ft.	12.78	12.78	12.78	12.78
	Tube diameter - in.	3/8	3/8	3/8	3/8
	Number of rows	2	2	4	4
	Fins per inch	14	14	14	14
Drain connection - Number and size		(1) 1 in. NPT coupling			
Expansion device type		Refrigerant Metering Orifice (RFC)		Balance port TXV, removable head	
<sup>2</sup> Indoor Blower and Drive Selection	Nominal motor output	2 hp, 3 hp, 5 hp			
	Maximum usable motor output (US Only)	2.3 hp, 3.45 hp, 5.75 hp			
	Motor - Drive kit number	2 hp <b>Kit 1</b> 590-890 rpm <b>Kit 2</b> 800-1105 rpm <b>Kit 3</b> 795-1195 rpm 3 hp <b>Kit 4</b> 730-970 rpm <b>Kit 5</b> 940-1200 rpm <b>Kit 6</b> 1015-1300 rpm 5 hp <b>Kit 10</b> 900-1135 rpm <b>Kit 11</b> 1040-1315 rpm <b>Kit 12</b> 1125-1425 rpm			
Blower wheel nominal diameter x width - in.		(1) 15 X 15	(1) 15 X 15	(1) 15 X 15	(1) 15 X 15
Filters	Type of filter	Disposable			
	Number and size - in.	(4) 20 x 25 x 2			
Electrical characteristics		208/230V, 460V or 575V - 60 hertz - 3 phase			

NOTE - Net capacity includes evaporator blower motor heat deduction. Gross capacity does not include evaporator blower motor heat deduction.

<sup>1</sup> AHRI Certified to AHRI Standard 340/360; 95°F outdoor air temperature and 80°F db/67°F wb entering evaporator air; minimum external duct static pressure.

<sup>2</sup> Using total air volume and system static pressure requirements determine from blower performance tables rpm and motor output required. Maximum usable output of motors furnished are shown. In Canada, nominal motor output is also maximum usable motor output. If motors of comparable output are used, be sure to keep within the service factor limitations outlined on the motor nameplate.

NOTE – Units equipped with MSAV® (Multi-Stage Air Volume) option are limited to a motor service factor of 1.0.

SPECIFICATIONS		8.5 TON			
General Data	Nominal Tonnage	8.5 Ton	8.5 Ton	8.5 Ton	8.5 Ton
	Model Number	KCB102S4B	KCA102S4M	KCA102H4B	KCA102H4M
	Efficiency Type	Standard	Standard	High	High
	Blower Type	Constant Air Volume (CAV)	MSAV (Multi-Stage Air Volume)	Constant Air Volume (CAV)	MSAV (Multi-Stage Air Volume)
Cooling Performance	Gross Cooling Capacity - Btuh	99,600	99,600	103,800	103,800
	<sup>1</sup> Net Cooling Capacity - Btuh	97,000	97,000	100,000	100,000
	AHRI Rated Air Flow - cfm	2800	3400	3400	3400
	Total Unit Power - kW	8.7	8.7	8.1	8.1
	<sup>1</sup> EER (Btuh/Watt)	11.2	11.2	12.4	12.4
	<sup>1</sup> IEER (Btuh/Watt)	12.9	13.5	12.9	14.0
AHRI Reference Number		10609473	202088979	202089012	202090509
Refrigerant Charge Furnished	Refrigerant Type	R-410A	R-410A	R-410A	R-410A
	Circuit 1	4 lbs. 5 oz.	4 lbs. 5 oz.	6 lbs. 8 oz.	6 lbs. 8 oz.
	Circuit 2	4 lbs. 3 oz.	4 lbs. 3 oz.	6 lbs. 15 oz.	6 lbs. 15 oz.
Electric Heat Available - See page 3		7.5, 15, 22.5, 30 & 45 KW			
Compressor Type (number)		Scroll (2)	Scroll (2)	Scroll (2)	Scroll (2)
Outdoor Coils	Net face area (total) - sq. ft.	20.9	20.9	28.0	28.0
	Number of rows	1	1	1	1
	Fins per inch	23	23	20	20
Outdoor Coil Fans	Motor - (No.) hp	(2) 1/3	(2) 1/3	(2) 1/3	(2) 1/3
	Motor rpm	1075	1075	1075	1075
	Total Motor watts	740	740	800	800
	Diameter - (No.) in.	(2) 24	(2) 24	(2) 24	(2) 24
	Number of blades	3	3	3	3
	Total Air volume - cfm	8800	8800	8800	8800
Indoor Coils	Net face area (total) - sq. ft.	12.78	12.78	12.78	12.78
	Tube diameter - in.	3/8	3/8	3/8	3/8
	Number of rows	3	3	4	4
	Fins per inch	14	14	14	14
Drain connection - Number and size		(1) 1 in. NPT coupling			
Expansion device type		Refrigerant Metering Orifice (RFC)		Balance port TXV, removable head	
<sup>2</sup> Indoor Blower and Drive Selection	Nominal motor output	2 hp, 3 hp, 5 hp			
	Maximum usable motor output (US Only)	2.3 hp, 3.45 hp, 5.75 hp			
	Motor - Drive kit number	2 hp <b>Kit 1</b> 590-890 rpm <b>Kit 2</b> 800-1105 rpm <b>Kit 3</b> 795-1195 rpm 3 hp <b>Kit 4</b> 730-970 rpm <b>Kit 5</b> 940-1200 rpm <b>Kit 6</b> 1015-1300 rpm 5 hp <b>Kit 10</b> 900-1135 rpm <b>Kit 11</b> 1040-1315 rpm <b>Kit 12</b> 1125-1425 rpm			
	Blower wheel nominal diameter x width - in.	(1) 15 X 15	(1) 15 X 15	(1) 15 X 15	(1) 15 X 15
Filters	Type of filter	Disposable			
	Number and size - in.	(4) 20 x 25 x 2			
Electrical characteristics		208/230V, 460V or 575V - 60 hertz - 3 phase			

NOTE - Net capacity includes evaporator blower motor heat deduction. Gross capacity does not include evaporator blower motor heat deduction.

<sup>1</sup> AHRI Certified to AHRI Standard 340/360; 95°F outdoor air temperature and 80°F db/67°F wb entering evaporator air; minimum external duct static pressure.

<sup>2</sup> Using total air volume and system static pressure requirements determine from blower performance tables rpm and motor output required. Maximum usable output of motors furnished are shown. In Canada, nominal motor output is also maximum usable motor output. If motors of comparable output are used, be sure to keep within the service factor limitations outlined on the motor nameplate.

NOTE - Units equipped with MSAV® (Multi-Stage Air Volume) option are limited to a motor service factor of 1.0.

**SPECIFICATIONS**
**10 TON**

General Data		Nominal Tonnage	10 Ton	10 Ton	10 Ton	10 Ton
		Model Number	KCB120S4B	KCA120S4M	KCA120H4B	KCA120H4M
		Efficiency Type	Standard	Standard	High	High
		Blower Type	Constant Air Volume (CAV)	MSAV (Multi-Stage Air Volume)	Constant Air Volume (CAV)	MSAV (Multi-Stage Air Volume)
Cooling Performance	Gross Cooling Capacity - Btuh		118,000	118,400	122,000	122,000
	<sup>1</sup> Net Cooling Capacity - Btuh		115,000	115,000	118,000	118,000
	AHRI Rated Air Flow - cfm		3000	3800	3600	3300
	Total Unit Power - kW		10.3	10.3	9.7	9.7
	<sup>1</sup> EER (Btuh/Watt)		11.2	11.2	12.2	12.2
	<sup>1</sup> IEER (Btuh/Watt)		12.9	13.2	13.2	14.0
AHRI Reference Number			10609471	202088980	202088949	202090475
Refrigerant Charge Furnished	Refrigerant Type		R-410A	R-410A	R-410A	R-410A
	Circuit 1		5 lbs. 11 oz.	4 lbs. 12 oz.	7 lbs. 4 oz.	7 lbs. 4 oz.
	Circuit 2		5 lbs. 6 oz.	4 lbs. 10 oz.	7 lbs. 8 oz.	7 lbs. 8 oz.
Electric Heat Available - See page 3			15, 22.5, 30, 45 & 60 KW			
Compressor Type (number)			Scroll (2)	Scroll (2)	Scroll (2)	Scroll (2)
Outdoor Coils (Fin/Tube)	Net face area (total) - sq. ft.		28.0	28.0	28.0	28.0
	Number of rows		1	1	1	1
	Fins per inch		23	23	20	20
Outdoor Coil Fans	Motor - (No.) hp		(2) 1/3	(2) 1/3	(2) 1/3	(2) 1/3
	Motor rpm		1075	1075	1075	1075
	Total Motor watts		690	690	800	800
	Diameter - (No.) in.		(2) 24	(2) 24	(2) 24	(2) 24
	Number of blades		3	3	3	3
	Total Air volume - cfm		9300	9300	8800	8800
Indoor Coils	Net face area (total) - sq. ft.		12.78	12.78	13.54	13.54
	Tube diameter - in.		3/8	3/8	3/8	3/8
	Number of rows		4	3	4	4
	Fins per inch		14	14	14	14
Drain connection - Number and size			(1) 1 in. NPT coupling			
Expansion device type			Refrigerant Metering Orifice (RFC)		Balance port TXV, removable head	
<sup>2</sup> Indoor Blower and Drive Selection	Nominal motor output		2 hp, 3 hp, 5 hp			
	Maximum usable motor output (US Only)		2.3 hp, 3.45 hp, 5.75 hp			
	Motor - Drive kit number		2 hp <b>Kit 1</b> 590-890 rpm <b>Kit 2</b> 800-1105 rpm <b>Kit 3</b> 795-1195 rpm 3 hp <b>Kit 4</b> 730-970 rpm <b>Kit 5</b> 940-1200 rpm <b>Kit 6</b> 1015-1300 rpm 5 hp <b>Kit 10</b> 900-1135 rpm <b>Kit 11</b> 1040-1315 rpm <b>Kit 12</b> 1125-1425 rpm			
Blower wheel nominal diameter x width - in.			(1) 15 X 15	(1) 15 X 15	(1) 15 X 15	(1) 15 X 15
Filters	Type of filter		Disposable			
	Number and size - in.		(4) 20 x 25 x 2			
Electrical characteristics			208/230V, 460V or 575V - 60 hertz - 3 phase			

NOTE - Net capacity includes evaporator blower motor heat deduction. Gross capacity does not include evaporator blower motor heat deduction.

<sup>1</sup> AHRI Certified to AHRI Standard 340/360; 95°F outdoor air temperature and 80°F db/67°F wb entering evaporator air; minimum external duct static pressure.

<sup>2</sup> Using total air volume and system static pressure requirements determine from blower performance tables rpm and motor output required. Maximum usable output of motors furnished are shown. In Canada, nominal motor output is also maximum usable motor output. If motors of comparable output are used, be sure to keep within the service factor limitations outlined on the motor nameplate.

NOTE - Units equipped with MSAV® (Multi-Stage Air Volume) option are limited to a motor service factor of 1.0.

**SPECIFICATIONS**

**12.5 TON**

General Data		Nominal Tonnage	12.5 Ton	12.5 Ton
		Model Number	KCB150S4B	KCB150S4M
		Efficiency Type	Standard	Standard
		Blower Type	Constant Air Volume (CAV)	MSAV (Multi-Stage Air Volume)
Cooling Performance	Gross Cooling Capacity - Btuh		148,000	148,000
	<sup>1</sup> Net Cooling Capacity - Btuh		142,000	142,000
	AHRI Rated Air Flow - cfm		3950	3950
	Total Unit Power - kW		12.9	12.9
	<sup>1</sup> EER (Btuh/Watt)		11.0	11.0
	<sup>1</sup> IEER (Btuh/Watt)		12.4	13.5
AHRI Reference Number			10609467	10609469
Refrigerant Charge Furnished		Refrigerant Type	R-410A	R-410A
		Circuit 1	12 lbs. 8 oz.	12 lbs. 8 oz.
		Circuit 2	10 lbs. 12 oz.	10 lbs. 12 oz.
Electric Heat Available - See page 3		15, 22.5,30, 45 & 60 KW		
Compressor Type (number)		Scroll (2)		Scroll (2)
Outdoor Coils (Fin/Tube)	Net face area (total) - sq. ft.		25.9	25.9
	Number of rows		3	3
	Fins per inch		20	20
Outdoor Coil Fans	Motor - (No.) hp		(2) 1/2	(2) 1/2
	Motor rpm		1075	1075
	Total Motor watts		1050	1050
	Diameter - (No.) in.		(2) 24	(2) 24
	Number of blades		3	3
	Total Air volume - cfm		9700	9700
Indoor Coils	Net face area (total) - sq. ft.		13.54	13.54
	Tube diameter - in.		3/8	3/8
	Number of rows		4	4
	Fins per inch		14	14
Drain connection - Number and size		(1) 1 in. NPT coupling		
Expansion device type		Balance port TXV, removable head		
<sup>2</sup> Indoor Blower and Drive Selection	Nominal motor output		2 hp, 3 hp, 5 hp	
	Maximum usable motor output (US Only)		2.3 hp, 3.45 hp, 5.75 hp	
	Motor - Drive kit number		2 hp <b>Kit 1</b> 590-890 rpm <b>Kit 2</b> 800-1105 rpm <b>Kit 3</b> 795-1195 rpm 3 hp <b>Kit 4</b> 730-970 rpm <b>Kit 5</b> 940-1200 rpm <b>Kit 6</b> 1015-1300 rpm 5 hp <b>Kit 10</b> 900-1135 rpm <b>Kit 11</b> 1040-1315 rpm <b>Kit 12</b> 1125-1425 rpm	
	Blower wheel nominal diameter x width - in.		(1) 15 X 15	(1) 15 X 15
Filters	Type of filter		Disposable	
	Number and size - in.		(4) 20 x 25 x 2	
Electrical characteristics		208/230V, 460V or 575V - 60 hertz - 3 phase		

NOTE - Net capacity includes evaporator blower motor heat deduction. Gross capacity does not include evaporator blower motor heat deduction.

<sup>1</sup> AHRI Certified to AHRI Standard 340/360; 95°F outdoor air temperature and 80°F db/67°F wb entering evaporator air; minimum external duct static pressure.

<sup>2</sup> Using total air volume and system static pressure requirements determine from blower performance tables rpm and motor output required. Maximum usable output of motors furnished are shown. In Canada, nominal motor output is also maximum usable motor output. If motors of comparable output are used, be sure to keep within the service factor limitations outlined on the motor nameplate.

NOTE – Units equipped with MSAV® (Multi-Stage Air Volume) option are limited to a motor service factor of 1.0.



## BLOWER DATA

092S STANDARD EFFICIENCY BELT DRIVE BLOWER – BASE UNIT

BLOWER TABLE INCLUDES RESISTANCE FOR BASE UNIT ONLY (NO HEAT SECTION) WITH DRY INDOOR COIL AND AIR FILTERS IN PLACE. FOR ALL UNITS ADD:

- 1 – Wet indoor coil air resistance of selected unit.
- 2 – Any factory installed options air resistance (heat section, economizer, etc.)
- 3 – Any field installed accessories air resistance (duct resistance, diffuser, etc.)

Then determine from blower table blower motor output required.

See page 13 for blower motors and drives.

See page 13 for wet coil and option/accessory air resistance data.

MINIMUM AIR VOLUME REQUIRED FOR USE WITH OPTIONAL ELECTRIC HEAT (Maximum Static Pressure - 2.0 in. w.g.)

7.5 kW, 15 kW, 22.5 kW, 30 kW and 45 kW - 2800 cfm

Total Air Volume cfm	Total Static Pressure – in. w.g.																											
	0.2		0.4		0.6		0.8		1.0		1.2		1.4		1.6		1.8		2		2.2		2.4		2.6			
	RPM	BHP	RPM	BHP	RPM	BHP	RPM	BHP	RPM	BHP	RPM	BHP	RPM	BHP	RPM	BHP	RPM	BHP	RPM	BHP	RPM	BHP	RPM	BHP	RPM	BHP	RPM	BHP
1750	608	0.05	651	0.03	696	0.06	744	0.22	794	0.60	845	0.95	894	1.24	934	1.38	978	1.47	1047	1.66	1120	1.89	1179	2.15	1230	2.40		
2000	615	0.07	657	0.05	702	0.10	748	0.36	797	0.72	846	1.05	892	1.30	933	1.45	977	1.55	1049	1.75	1124	2.00	1181	2.23	1234	2.47		
2250	624	0.09	664	0.07	707	0.14	753	0.50	800	0.84	847	1.15	892	1.38	934	1.53	979	1.65	1051	1.86	1126	2.12	1183	2.36	1238	2.62		
2500	632	0.11	672	0.09	714	0.29	758	0.64	803	0.97	849	1.26	893	1.48	936	1.63	983	1.75	1052	1.96	1124	2.22	1184	2.49	1241	2.77		
2750	641	0.13	680	0.11	721	0.45	763	0.78	807	1.09	852	1.37	896	1.58	940	1.74	989	1.88	1053	2.08	1121	2.34	1185	2.63	1244	2.93		
3000	651	0.15	689	0.29	728	0.61	770	0.93	812	1.23	856	1.49	901	1.70	947	1.87	996	2.02	1055	2.21	1120	2.47	1186	2.78	1248	3.10		
3250	661	0.17	698	0.46	737	0.78	777	1.09	819	1.38	862	1.63	908	1.84	955	2.01	1004	2.17	1059	2.36	1122	2.62	1189	2.94	1252	3.28		
3500	672	0.36	708	0.65	746	0.95	786	1.25	827	1.53	870	1.78	916	1.99	965	2.17	1013	2.33	1065	2.52	1126	2.79	1193	3.12	1257	3.47		
3750	684	0.56	719	0.85	756	1.14	795	1.43	836	1.70	880	1.95	927	2.16	976	2.34	1023	2.51	1073	2.71	1133	2.98	1198	3.32	1263	3.67		
4000	697	0.78	731	1.05	768	1.34	807	1.62	848	1.89	892	2.13	940	2.34	988	2.53	1034	2.71	1083	2.91	1141	3.19	1205	3.53	1270	3.89		
4250	710	1.00	745	1.27	781	1.55	819	1.83	861	2.09	906	2.33	954	2.55	1001	2.74	1046	2.93	1094	3.14	1151	3.42	1214	3.76	1278	4.12		

## BLOWER DATA

### 092H AND 102H HIGH EFFICIENCY BELT DRIVE BLOWER – BASE UNIT

BLOWER TABLE INCLUDES RESISTANCE FOR BASE UNIT ONLY (NO HEAT SECTION) WITH DRY INDOOR COIL AND AIR FILTERS IN PLACE. FOR ALL UNITS ADD:

- 1 – Wet indoor coil air resistance of selected unit.
- 2 – Any factory installed options air resistance (heat section, economizer, etc.)
- 3 – Any field installed accessories air resistance (duct resistance, diffuser, etc.)

Then determine from blower table blower motor output required.

See page 13 for blower motors and drives.

See page 13 for wet coil and option/accessory air resistance data.

MINIMUM AIR VOLUME REQUIRED FOR USE WITH OPTIONAL ELECTRIC HEAT (Maximum Static Pressure - 2.0 in. w.g.)

7.5 kW, 15 kW, 22.5 kW, 30 kW and 45 kW - 2800 cfm

Total Air Volume cfm	Total Static Pressure – in. w.g.																									
	0.2		0.4		0.6		0.8		1.0		1.2		1.4		1.6		1.8		2.0		2.2		2.4		2.6	
	RPM	BHP	RPM	BHP	RPM	BHP	RPM	BHP	RPM	BHP	RPM	BHP	RPM	BHP	RPM	BHP	RPM	BHP	RPM	BHP	RPM	BHP	RPM	BHP	RPM	BHP
1750	481	0.21	549	0.4	618	0.57	688	0.7	758	0.82	824	0.93	885	1.08	941	1.23	991	1.39	1038	1.54	1082	1.68	1124	1.82	1166	1.95
2000	493	0.29	561	0.47	629	0.64	700	0.77	768	0.9	832	1.02	892	1.17	946	1.33	995	1.49	1041	1.66	1085	1.81	1126	1.97	1167	2.12
2250	507	0.37	574	0.56	643	0.72	712	0.86	779	0.99	842	1.13	900	1.28	953	1.44	1001	1.61	1045	1.78	1088	1.95	1128	2.12	1168	2.3
2500	521	0.46	588	0.64	657	0.81	727	0.95	792	1.09	853	1.24	909	1.4	960	1.57	1007	1.74	1050	1.93	1091	2.11	1130	2.29	1170	2.48
2750	537	0.56	604	0.74	674	0.91	743	1.06	806	1.21	865	1.36	920	1.53	969	1.71	1014	1.89	1055	2.08	1095	2.27	1133	2.47	1172	2.66
3000	554	0.67	622	0.86	692	1.02	760	1.18	822	1.34	878	1.5	931	1.68	979	1.86	1021	2.06	1061	2.26	1099	2.46	1136	2.65	1174	2.85
3250	572	0.78	641	0.98	712	1.15	778	1.32	838	1.49	892	1.66	943	1.84	989	2.03	1030	2.24	1068	2.45	1105	2.65	1141	2.85	1178	3.06
3500	592	0.9	663	1.12	733	1.3	798	1.47	855	1.65	907	1.83	956	2.02	1000	2.22	1039	2.44	1076	2.65	1111	2.86	1146	3.07	1183	3.27
3750	614	1.04	687	1.28	756	1.47	818	1.65	872	1.83	923	2.02	970	2.22	1011	2.43	1049	2.65	1084	2.87	1118	3.09	1152	3.29	1189	3.51
4000	639	1.22	713	1.48	780	1.66	838	1.83	890	2.02	939	2.22	984	2.44	1023	2.66	1059	2.89	1093	3.11	1126	3.33	1160	3.54	1197	3.77
4250	667	1.43	741	1.69	805	1.86	859	2.02	909	2.22	956	2.45	998	2.68	1036	2.92	1070	3.15	1103	3.37	1135	3.59	1169	3.81	1207	4.05

## BLOWER DATA

102S AND 120S (MSAV) STANDARD EFFICIENCY BELT DRIVE BLOWER – BASE UNIT

BLOWER TABLE INCLUDES RESISTANCE FOR BASE UNIT ONLY (NO HEAT SECTION) WITH DRY INDOOR COIL AND AIR FILTERS IN PLACE. FOR ALL UNITS ADD:

- 1 – Wet indoor coil air resistance of selected unit.
- 2 – Any factory installed options air resistance (heat section, economizer, etc.)
- 3 – Any field installed accessories air resistance (duct resistance, diffuser, etc.)

Then determine from blower table blower motor output required.

See page 13 for blower motors and drives.

See page 13 for wet coil and option/accessory air resistance data.

MINIMUM AIR VOLUME REQUIRED FOR USE WITH OPTIONAL ELECTRIC HEAT (Maximum Static Pressure - 2.0 in. w.g.)

15 kW, 22.5 kW, 30 kW and 45 kW - 2800 cfm

60 kW - 4000 cfm

Total Air Volume cfm	Total Static Pressure – in. w.g.																									
	0.2		0.4		0.6		0.8		1.0		1.2		1.4		1.6		1.8		2		2.2		2.4		2.6	
	RPM	BHP	RPM	BHP	RPM	BHP	RPM	BHP	RPM	BHP	RPM	BHP	RPM	BHP	RPM	BHP	RPM	BHP	RPM	BHP	RPM	BHP	RPM	BHP	RPM	BHP
2000	593	0.11	636	0.07	682	0.10	731	0.22	784	0.60	840	0.96	898	1.26	948	1.38	996	1.47	1045	1.57	1092	1.71	1140	1.92	1188	2.32
2250	604	0.15	645	0.11	690	0.15	739	0.39	790	0.74	846	1.08	901	1.34	953	1.48	1002	1.57	1052	1.70	1100	1.86	1149	2.09	1197	2.42
2500	615	0.19	655	0.15	699	0.20	747	0.55	797	0.89	851	1.20	906	1.44	959	1.58	1009	1.68	1059	1.83	1108	2.01	1158	2.26	1206	2.52
2750	626	0.23	666	0.19	709	0.37	755	0.71	805	1.03	858	1.32	912	1.55	966	1.70	1017	1.81	1067	1.97	1117	2.17	1166	2.44	1215	2.71
3000	637	0.27	677	0.24	719	0.55	764	0.87	813	1.18	866	1.45	920	1.67	975	1.82	1026	1.96	1076	2.13	1126	2.35	1176	2.63	1225	2.92
3250	650	0.31	688	0.43	730	0.73	775	1.04	823	1.34	875	1.60	930	1.81	985	1.97	1036	2.12	1086	2.31	1136	2.54	1186	2.83	1235	3.13
3500	663	0.35	700	0.63	741	0.92	786	1.22	834	1.50	886	1.76	942	1.96	997	2.14	1048	2.31	1097	2.51	1147	2.75	1196	3.04	1245	3.35
3750	676	0.57	714	0.84	754	1.12	798	1.41	846	1.68	899	1.93	956	2.14	1010	2.32	1060	2.51	1109	2.72	1158	2.98	1207	3.27	1255	3.58
4000	691	0.79	728	1.05	768	1.33	812	1.61	860	1.88	914	2.12	971	2.34	1023	2.53	1072	2.73	1121	2.95	1169	3.22	1218	3.51	1266	3.83
4250	706	1.03	743	1.28	783	1.55	827	1.82	876	2.09	931	2.33	987	2.55	1037	2.76	1085	2.97	1133	3.20	1181	3.47	1229	3.76	1277	4.08
4500	722	1.27	759	1.52	799	1.78	844	2.05	894	2.31	949	2.56	1003	2.79	1052	3.00	1098	3.22	1145	3.46	1193	3.73	1241	4.03	1289	4.34
4750	739	1.53	776	1.77	817	2.03	862	2.30	913	2.56	968	2.81	1020	3.04	1066	3.27	1112	3.49	1158	3.74	1205	4.01	1253	4.30	1301	4.61
5000	757	1.79	794	2.04	835	2.30	882	2.56	934	2.83	988	3.08	1036	3.32	1081	3.55	1125	3.78	1171	4.02	1218	4.29	1265	4.59	1312	4.89

## BLOWER DATA

120H AND 120S (CAV) HIGH EFFICIENCY AND 150S STANDARD EFFICIENCY BELT DRIVE BLOWER – BASE UNIT  
 BLOWER TABLE INCLUDES RESISTANCE FOR BASE UNIT ONLY (NO HEAT SECTION) WITH DRY INDOOR COIL AND AIR  
 FILTERS IN PLACE. FOR ALL UNITS ADD:

- 1 – Wet indoor coil air resistance of selected unit.
- 2 – Any factory installed options air resistance (heat section, economizer, etc.)
- 3 – Any field installed accessories air resistance (duct resistance, diffuser, etc.)

Then determine from blower table blower motor output required.

See page 13 for blower motors and drives.

See page 13 for wet coil and option/accessory air resistance data.

MINIMUM AIR VOLUME REQUIRED FOR USE WITH OPTIONAL ELECTRIC HEAT (Maximum Static Pressure - 2.0 in. w.g.)

15 kW, 22.5 kW, 30 kW and 45 kW - 2800 cfm

60 kW - 4000 cfm

Total Air Volume cfm	Total Static Pressure – in. w.g.																										
	0.2		0.4		0.6		0.8		1.0		1.2		1.4		1.6		1.8		2.0		2.2		2.4		2.6		
	RPM	BHP	RPM	BHP	RPM	BHP	RPM	BHP	RPM	BHP	RPM	BHP	RPM	BHP	RPM	BHP	RPM	BHP	RPM	BHP	RPM	BHP	RPM	BHP	RPM	BHP	RPM
2000	497	0.25	558	0.44	624	0.6	694	0.74	764	0.85	830	0.99	889	1.16	943	1.34	994	1.52	1045	1.71	1096	1.89	1146	2.08	1197	2.27	
2250	511	0.34	573	0.52	638	0.68	708	0.82	776	0.94	839	1.09	896	1.26	948	1.45	998	1.64	1048	1.83	1098	2.01	1149	2.2	1200	2.4	
2500	527	0.44	589	0.62	654	0.78	723	0.91	789	1.05	850	1.21	904	1.39	955	1.58	1003	1.77	1052	1.96	1101	2.14	1152	2.33	1203	2.53	
2750	545	0.55	606	0.72	672	0.88	740	1.03	804	1.17	861	1.34	914	1.53	962	1.72	1010	1.92	1057	2.10	1105	2.29	1154	2.47	1206	2.68	
3000	564	0.66	626	0.84	692	1.01	759	1.16	819	1.32	874	1.49	924	1.68	971	1.88	1017	2.08	1063	2.26	1110	2.44	1158	2.63	1208	2.83	
3250	585	0.79	648	0.98	714	1.14	778	1.31	836	1.48	887	1.66	935	1.86	981	2.06	1026	2.26	1071	2.45	1117	2.63	1163	2.80	1213	3.00	
3500	607	0.93	672	1.13	737	1.31	798	1.48	852	1.66	901	1.85	948	2.05	993	2.26	1037	2.46	1081	2.65	1125	2.83	1171	3.01	1221	3.21	
3750	632	1.10	698	1.31	762	1.50	819	1.67	869	1.86	915	2.05	961	2.25	1005	2.47	1049	2.68	1092	2.88	1136	3.05	1181	3.24	1231	3.45	
4000	660	1.30	726	1.52	787	1.70	838	1.87	885	2.06	930	2.26	974	2.48	1018	2.71	1062	2.93	1105	3.12	1149	3.30	1194	3.49	1245	3.72	
4250	691	1.53	755	1.75	810	1.91	857	2.07	901	2.27	945	2.50	990	2.74	1034	2.98	1077	3.20	1120	3.39	1163	3.58	1210	3.79	1262	4.03	
4500	724	1.78	783	1.98	831	2.12	874	2.28	917	2.50	962	2.75	1006	3.02	1051	3.27	1094	3.49	1137	3.70	1181	3.89	1228	4.11	1281	4.38	
4750	757	2.05	809	2.20	851	2.33	891	2.51	935	2.76	980	3.05	1025	3.33	1070	3.59	1113	3.82	1156	4.03	1201	4.24	1249	4.47	1303	4.75	
5000	787	2.31	831	2.43	870	2.57	910	2.78	954	3.06	1000	3.38	1046	3.68	1091	3.95	1135	4.19	1178	4.40	1224	4.62	1272	4.86	1325	5.13	
5250	814	2.55	852	2.66	889	2.83	930	3.09	975	3.41	1023	3.76	1070	4.08	1115	4.35	1159	4.59	1203	4.81	1248	5.03	1297	5.27	1350	5.53	
5500	835	2.78	871	2.91	909	3.13	952	3.44	999	3.81	1049	4.18	1096	4.51	1142	4.79	1186	5.03	1229	5.24	1275	5.46	1324	5.69	---	---	
5750	854	3.01	890	3.19	930	3.48	977	3.86	1027	4.27	1078	4.66	1126	4.99	1171	5.26	1214	5.49	1258	5.70	---	---	---	---	---	---	
6000	871	3.26	910	3.53	955	3.90	1006	4.34	1060	4.80	1111	5.19	1158	5.51	---	---	---	---	---	---	---	---	---	---	---	---	
6250	890	3.57	934	3.94	985	4.41	1041	4.91	1096	5.38	---	---	---	---	---	---	---	---	---	---	---	---	---	---	---	---	

## BLOWER DATA

### FACTORY INSTALLED BELT DRIVE KIT SPECIFICATIONS

Nominal hp	Maximum hp	Drive Kit Number	RPM Range
2	2.3	1	590 - 890
2	2.3	2	800 - 1105
2	2.3	3	795 - 1195
3	3.45	4	730 - 970
3	3.45	5	940 - 1200
3	3.45	6	1015 - 1300
5	5.75	10	900 - 1135
5	5.75	11	1040 - 1315
5	5.75	12	1125 - 1425

NOTE - Using total air volume and system static pressure requirements determine from blower performance tables rpm and motor output required. Maximum usable output of motors furnished are shown. In Canada, nominal motor output is also maximum usable motor output. If motors of comparable output are used, be sure to keep within the service factor limitations outlined on the motor nameplate.

NOTE - Units equipped with MSAV® (Multi-Stage Air Volume) option are limited to a motor service factor of 1.0.

### POWER EXHAUST FAN PERFORMANCE

Return Air System Static Pressure in. w.g.	Air Volume Exhausted cfm
0	3175
0.05	2955
0.10	2685
0.15	2410
0.20	2165
0.25	1920
0.30	1420
0.35	1200

### FACTORY INSTALLED OPTIONS/FIELD INSTALLED ACCESSORY AIR RESISTANCE - in. w.g.

Air Volume cfm	Wet Indoor Coil		Electric Heat	Economizer	Filters		Return Air Adaptor Plate
	092, 102	120, 150			MERV 8	MERV 13	
1750	0.04	0.04	0.03	0.05	0.01	0.03	0.00
2000	0.05	0.05	0.03	0.06	0.01	0.03	0.00
2250	0.06	0.06	0.04	0.08	0.01	0.04	0.00
2500	0.07	0.07	0.04	0.11	0.01	0.05	0.00
2750	0.08	0.08	0.05	0.12	0.02	0.05	0.00
3000	0.10	0.09	0.06	0.13	0.02	0.06	0.02
3250	0.11	0.10	0.06	0.15	0.02	0.06	0.02
3500	0.12	0.11	0.09	0.15	0.03	0.07	0.04
3750	0.14	0.13	0.09	0.15	0.03	0.08	0.07
4000	0.15	0.14	0.09	0.19	0.04	0.08	0.09
4250	0.17	0.15	0.13	0.19	0.04	0.09	0.11
4500	0.19	0.17	0.14	0.22	0.04	0.09	0.12
4750	0.20	0.18	0.17	0.25	0.05	0.10	0.16
5000	0.22	0.20	0.20	0.29	0.06	0.10	0.18
5250	0.24	0.22	0.22	0.32	0.06	0.11	0.19
5500	0.25	0.23	0.25	0.34	0.07	0.12	0.22
5750	0.27	0.25	0.31	0.45	0.07	0.12	0.25
6000	0.29	0.27	0.33	0.52	0.08	0.13	0.27

## BLOWER DATA

### CEILING DIFFUSERS AIR RESISTANCE - in. w.g.

Unit Size	RTD11 Step-Down Diffuser				FD11 Flush Diffuser
	Air Volume cfm	2 Ends Open	1 Side, 2 Ends Open	All Ends & Sides Open	
092 Models	2400	0.21	0.18	0.15	0.14
	2600	0.24	0.21	0.18	0.17
	2800	0.27	0.24	0.21	0.20
	3000	0.32	0.29	0.25	0.25
	3200	0.41	0.37	0.32	0.31
	3400	0.50	0.45	0.39	0.37
	3600	0.61	0.54	0.48	0.44
	3800	0.73	0.63	0.57	0.51
102 & 120 Models	3600	0.36	0.28	0.23	0.15
	3800	0.40	0.32	0.26	0.18
	4000	0.44	0.36	0.29	0.21
	4200	0.49	0.40	0.33	0.24
	4400	0.54	0.44	0.37	0.27
	4600	0.60	0.49	0.42	0.31
	4800	0.65	0.53	0.46	0.35
	5000	0.69	0.58	0.50	0.39
150 Models	4200	0.22	0.19	0.16	0.10
	4400	0.28	0.24	0.20	0.12
	4600	0.34	0.29	0.24	0.15
	4800	0.40	0.34	0.29	0.19
	5000	0.46	0.39	0.34	0.23
	5200	0.52	0.44	0.39	0.27
	5400	0.58	0.49	0.43	0.31
	5600	0.64	0.54	0.47	0.35
5800	0.70	0.59	0.51	0.39	

### CEILING DIFFUSER AIR THROW DATA

Model No.	Air Volume cfm	<sup>1</sup> Effective Throw Range	
		RTD11 Step-Down ft.	FD11 Flush ft.
092 Models	2600	24 - 29	19 - 24
	2800	25 - 30	20 - 28
	3000	27 - 33	21 - 29
	3200	28 - 35	22 - 29
	3400	30 - 37	22 - 30
102, 120 Models	3600	25 - 33	22 - 29
	3800	27 - 35	22 - 30
	4000	29 - 37	24 - 33
	4200	32 - 40	26 - 35
	4400	34 - 42	28 - 37
150 Models	5600	39 - 49	28 - 37
	5800	42 - 51	29 - 38
	6000	44 - 54	40 - 50
	6200	45 - 55	42 - 51
	6400	46 - 55	43 - 52
6600	47 - 56	45 - 56	

<sup>1</sup> Throw is the horizontal or vertical distance an air stream travels on leaving the outlet or diffuser before the maximum velocity is reduced to 50 ft. per minute. Four sides open.

**ELECTRICAL/ELECTRIC HEAT DATA**

**7.5 TON**

**7.5 TON STANDARD EFFICIENCY (R-410A)**

**KCA/KCB092S4**

<sup>1</sup> Voltage - 60hz		208/230V - 3 Ph			460V - 3 Ph			575V - 3 Ph		
Compressor 1	Rated Load Amps	13.1			6.1			4.4		
	Locked Rotor Amps	83.1			41			33		
Compressor 2	Rated Load Amps	13.1			6.1			4.4		
	Locked Rotor Amps	83.1			41			33		
Outdoor Fan Motors (2)	Full Load Amps (total)	2.4 (4.8)			1.3 (2.6)			1 (2)		
Power Exhaust (1) 0.33 HP	Full Load Amps	2.4			1.3			1		
Service Outlet 115V GFI (amps)		15			15			20		
Indoor Blower Motor	Horsepower	2	3	5	2	3	5	2	3	5
	Full Load Amps	7.5	10.5	16.7	3.4	4.8	7.6	2.7	3.9	6.1
<sup>2</sup> Maximum Overcurrent Protection	Unit Only	50	50	60	25	25	30	15	20	20
	With (1) 0.33 HP Power Exhaust	50	60	70	25	25	30	20	20	25
<sup>3</sup> Minimum Circuit Ampacity	Unit Only	42	45	52	20	22	25	15	16	19
	With (1) 0.33 HP Power Exhaust	45	48	55	22	23	26	16	17	20

**ELECTRIC HEAT DATA**

Electric Heat Voltage			208V	240V	208V	240V	208V	240V	480V	480V	480V	600V	600V	600V
<sup>2</sup> Maximum Overcurrent Protection	Electric Heat and (1) 0.33 HP Power Exhaust	Unit+ 7.5 kW	50	50	50	50	60	60	25	25	30	15	20	20
		15 kW	50	60	60	60	60	70	30	30	35	25	25	30
		22.5 kW	70	80	80	90	80	90	40	40	45	35	35	35
		30 kW	90	100	100	110	100	125	50	60	60	40	45	45
		45 kW	150	150	150	150	150	175	80	80	80	60	60	70
<sup>3</sup> Minimum Circuit Ampacity	Electric Heat and (1) 0.33 HP Power Exhaust	Unit+ 7.5 kW	42	42	45	45	52	52	20	22	25	15	16	19
		15 kW	49	55	53	59	60	66	27	29	33	22	23	26
		22.5 kW	69	78	72	81	80	89	39	40	44	31	32	35
		30 kW	88	100	92	104	100	112	50	52	55	40	41	44
		45 kW	127	145	131	149	139	157	72	74	78	58	60	62
<sup>2</sup> Maximum Overcurrent Protection	Unit+ Electric Heat and (1) 0.33 HP Power Exhaust	7.5 kW	50	50	60	60	70	70	25	25	30	20	20	25
		15 kW	60	60	60	70	70	70	30	35	35	25	25	30
		22.5 kW	80	90	80	90	90	100	40	45	45	35	35	40
		30 kW	100	110	100	110	110	125	60	60	60	45	45	45
		45 kW	150	150	150	175	150	175	80	80	80	60	70	70
<sup>3</sup> Minimum Circuit Ampacity	Unit+ Electric Heat and (1) 0.33 HP Power Exhaust	7.5 kW	45	45	48	48	55	55	22	23	26	16	17	20
		15 kW	52	58	56	62	63	69	29	31	34	23	25	27
		22.5 kW	72	81	75	84	83	92	40	42	45	32	34	36
		30 kW	91	103	95	107	103	115	51	53	57	41	43	45
		45 kW	130	148	134	152	142	160	74	76	79	59	61	64

**ELECTRICAL ACCESSORIES**

Disconnect	7.5 kW	54W56			54W56			54W56		
	15 kW	54W56			54W56			54W56		
	22.5 kW	54W56			54W56			54W56		
	30 kW	54W57			54W56			54W56		
	45 kW	54W57			54W56			54W56		

NOTE - All units have a minimum Short Circuit Current Rating (SCCR) of 5000 amps.

<sup>1</sup> Extremes of operating range are plus and minus 10% of line voltage.

<sup>2</sup> HACR type breaker or fuse.

<sup>3</sup> Refer to National or Canadian Electrical Code manual to determine wire, fuse and disconnect size requirements.

**ELECTRICAL/ELECTRIC HEAT DATA**

**7.5 TON**

**7.5 TON HIGH EFFICIENCY (R-410A)**

**KCA092H4**

<sup>1</sup> Voltage - 60hz		208/230V - 3 Ph			460V - 3 Ph			575V - 3 Ph		
Compressor 1	Rated Load Amps	11.6			5.5			4.7		
	Locked Rotor Amps	86			37			34		
Compressor 2	Rated Load Amps	11.6			5.5			4.7		
	Locked Rotor Amps	86			37			34		
Outdoor Fan Motors (2)	Full Load Amps (total)	2.4 (4.8)			1.3 (2.6)			1 (2)		
Power Exhaust (1) 0.33 HP	Full Load Amps	2.4			1.3			1		
Service Outlet 115V GFI (amps)		15			15			20		
Indoor Blower Motor	Horsepower	2	3	5	2	3	5	2	3	5
	Full Load Amps	7.5	10.6	16.7	3.4	4.8	7.6	2.7	3.9	6.1
<sup>2</sup> Maximum Overcurrent Protection	Unit Only	45	50	60	20	25	30	20	20	25
	With (1) 0.33 HP Power Exhaust	50	50	60	25	25	30	20	20	25
<sup>3</sup> Minimum Circuit Ampacity	Unit Only	39	42	49	19	20	24	16	17	20
	With (1) 0.33 HP Power Exhaust	41	44	52	20	22	25	17	18	21

**ELECTRIC HEAT DATA**

Electric Heat Voltage		208V	240V	208V	240V	208V	240V	480V	480V	480V	600V	600V	600V
<sup>2</sup> Maximum Overcurrent Protection	Unit+ 7.5 kW	45	45	50	50	60	60	20	25	30	20	20	25
	Electric Heat 15 kW	50	60	60	60	60	70	30	30	35	25	25	30
	22.5 kW	70	80	80	90	80	90	40	40	45	35	35	35
	30 kW	90	100	100	110	100	125	50	60	60	40	45	45
	45 kW	150	150	150	150	150	175	80	80	80	60	60	70
<sup>3</sup> Minimum Circuit Ampacity	Unit+ 7.5 kW	39	39	42	42	49	49	19	20	24	16	17	20
	Electric Heat 15 kW	49	55	53	59	60	66	27	29	33	22	23	26
	22.5 kW	69	78	72	81	80	89	39	40	44	31	32	35
	30 kW	88	100	92	104	100	112	50	52	55	40	41	44
	45 kW	127	145	131	149	139	157	72	74	78	58	60	62
<sup>2</sup> Maximum Overcurrent Protection	Unit+ 7.5 kW	50	50	50	50	60	60	25	25	30	20	20	25
	Electric Heat 15 kW	60	60	60	70	70	70	30	35	35	25	25	30
	and (1) 0.33 HP 22.5 kW	80	90	80	90	90	100	40	45	45	35	35	40
	Power Exhaust 30 kW	100	110	100	110	110	125	60	60	60	45	45	45
	45 kW	150	150	150	175	150	175	80	80	80	60	70	70
<sup>3</sup> Minimum Circuit Ampacity	Unit+ 7.5 kW	41	41	44	44	52	52	20	22	25	17	18	21
	Electric Heat 15 kW	52	58	56	62	63	69	29	31	34	23	25	27
	and (1) 0.33 HP 22.5 kW	72	81	75	84	83	92	40	42	45	32	34	36
	Power Exhaust 30 kW	91	103	95	107	103	115	51	53	57	41	43	45
	45 kW	130	148	134	152	142	160	74	76	79	59	61	64

**ELECTRICAL ACCESSORIES**

Disconnect	7.5 kW	54W56			54W56		
	15 kW	54W56			54W56		
	22.5 kW	54W56	54W57		54W56		
	30 kW	54W57			54W56		
	45 kW	54W57			54W56		

NOTE - All units have a minimum Short Circuit Current Rating (SCCR) of 5000 amps.

<sup>1</sup> Extremes of operating range are plus and minus 10% of line voltage.

<sup>2</sup> HACR type breaker or fuse.

<sup>3</sup> Refer to National or Canadian Electrical Code manual to determine wire, fuse and disconnect size requirements.



**ELECTRICAL/ELECTRIC HEAT DATA**

**8.5 TON**

**8.5 TON STANDARD EFFICIENCY (R-410A)**

**KCA/KCB102S4**

<sup>1</sup> Voltage - 60hz		208/230V - 3 Ph			460V - 3 Ph			575V - 3 Ph		
Compressor 1	Rated Load Amps	11.9			6.7			5.4		
	Locked Rotor Amps	109			59			40		
Compressor 2	Rated Load Amps	11.9			6.7			5.4		
	Locked Rotor Amps	109			59			40		
Outdoor Fan Motors (2)	Full Load Amps (total)	2.4 (4.8)			1.3 (2.6)			1 (2)		
Power Exhaust (1) 0.33 HP	Full Load Amps	2.4			1.3			1		
Service Outlet 115V GFI (amps)		15			15			20		
Indoor Blower Motor	Horsepower	2	3	5	2	3	5	2	3	5
	Full Load Amps	7.5	10.6	16.7	3.4	4.8	7.6	2.7	3.9	6.1
<sup>2</sup> Maximum Overcurrent Protection	Unit Only	50	50	60	25	25	30	20	20	25
	With (1) 0.33 HP Power Exhaust	50	50	60	25	30	30	20	20	25
<sup>3</sup> Minimum Circuit Ampacity	Unit Only	40	43	50	22	23	26	17	19	21
	With (1) 0.33 HP Power Exhaust	42	45	52	23	24	27	18	20	22

**ELECTRIC HEAT DATA**

Electric Heat Voltage			208V	240V	208V	240V	208V	240V	480V	480V	480V	600V	600V	600V
<sup>2</sup> Maximum Overcurrent Protection	Unit+ 7.5 kW	Electric Heat	50	50	50	50	60	60	25	25	30	20	20	25
	15 kW		50	60	60	60	60	70	30	30	35	25	25	30
	22.5 kW		70	80	80	90	80	90	40	40	45	35	35	35
	30 kW		90	100	100	110	100	125	50	60	60	40	45	45
45 kW		150	150	150	150	150	175	80	80	80	60	60	70	
<sup>3</sup> Minimum Circuit Ampacity	Unit+ 7.5 kW	Electric Heat	40	40	43	43	50	50	22	23	26	17	19	21
	15 kW		49	55	53	59	60	66	27	29	33	22	23	26
	22.5 kW		69	78	72	81	80	89	39	40	44	31	32	35
	30 kW		88	100	92	104	100	112	50	52	55	40	41	44
45 kW		127	145	131	149	139	157	72	74	78	58	60	62	
<sup>2</sup> Maximum Overcurrent Protection	Unit+ 7.5 kW	Electric Heat	50	50	50	50	60	60	25	30	30	20	20	25
	15 kW		60	60	60	70	70	70	30	35	35	25	25	30
	22.5 kW		80	90	80	90	90	100	40	45	45	35	35	40
	30 kW		100	110	100	110	110	125	60	60	60	45	45	45
45 kW		150	150	150	175	150	175	80	80	80	60	70	70	
<sup>3</sup> Minimum Circuit Ampacity	Unit+ 7.5 kW	Electric Heat	42	42	45	45	52	52	23	24	27	18	20	22
	15 kW		52	58	56	62	63	69	29	31	34	23	25	27
	22.5 kW		72	81	75	84	83	92	40	42	45	32	34	36
	30 kW		91	103	95	107	103	115	51	53	57	41	43	45
45 kW		130	148	134	152	142	160	74	76	79	59	61	64	

**ELECTRICAL ACCESSORIES**

Disconnect	7.5 kW	54W56	54W56	54W56
	15 kW	54W56	54W56	54W56
	22.5 kW	54W56	54W56	54W56
	30 kW	54W57	54W56	54W56
	45 kW	54W57	54W56	54W56

NOTE - All units have a minimum Short Circuit Current Rating (SCCR) of 5000 amps.

<sup>1</sup> Extremes of operating range are plus and minus 10% of line voltage.

<sup>2</sup> HACR type breaker or fuse.

<sup>3</sup> Refer to National or Canadian Electrical Code manual to determine wire, fuse and disconnect size requirements.

**ELECTRICAL/ELECTRIC HEAT DATA**

**8.5 TON**

**8.5 TON HIGH EFFICIENCY (R-410A)**

**KCA102H4**

<sup>1</sup> Voltage - 60hz		208/230V - 3 Ph			460V - 3 Ph			575V - 3 Ph		
Compressor 1	Rated Load Amps	11			5.5			4.7		
	Locked Rotor Amps	86			37			34		
Compressor 2	Rated Load Amps	11			5.5			4.7		
	Locked Rotor Amps	86			37			34		
Outdoor Fan Motors (2)	Full Load Amps (total)	2.4 (4.8)			1.3 (2.6)			1 (2)		
Power Exhaust (1) 0.33 HP	Full Load Amps	2.4			1.3			1		
Service Outlet 115V GFI (amps)		15			15			20		
Indoor Blower Motor	Horsepower	2	3	5	2	3	5	2	3	5
	Full Load Amps	7.5	10.6	16.7	3.4	4.8	7.6	2.7	3.9	6.1
<sup>2</sup> Maximum Overcurrent Protection	Unit Only	45	50	60	20	25	30	20	20	25
	With (1) 0.33 HP Power Exhaust	50	50	60	25	25	30	20	20	25
<sup>3</sup> Minimum Circuit Ampacity	Unit Only	38	41	48	19	20	24	16	17	20
	With (1) 0.33 HP Power Exhaust	40	43	51	20	22	25	17	18	21

**ELECTRIC HEAT DATA**

Electric Heat Voltage		208V	240V	208V	240V	208V	240V	480V	480V	480V	600V	600V	600V
<sup>2</sup> Maximum Overcurrent Protection	Unit+ 7.5 kW	45	45	50	50	60	60	20	25	30	20	20	25
	Electric Heat 15 kW	50	60	60	60	60	70	30	30	35	25	25	30
	22.5 kW	70	80	80	90	80	90	40	40	45	35	35	35
	30 kW	90	100	100	110	100	125	50	60	60	40	45	45
<sup>3</sup> Minimum Circuit Ampacity	Unit+ 7.5 kW	38	38	41	41	48	48	19	20	24	16	17	20
	Electric Heat 15 kW	49	55	53	59	60	66	27	29	33	22	23	26
	22.5 kW	69	78	72	81	80	89	39	40	44	31	32	35
	30 kW	88	100	92	104	100	112	50	52	55	40	41	44
<sup>2</sup> Maximum Overcurrent Protection	Unit+ 7.5 kW	50	50	50	50	60	60	25	25	30	20	20	25
	Electric Heat 15 kW	60	60	60	70	70	70	30	35	35	25	25	30
	and (1) 0.33 HP 22.5 kW	80	90	80	90	90	100	40	45	45	35	35	40
	Power Exhaust 30 kW	100	110	100	110	110	125	60	60	60	45	45	45
<sup>3</sup> Minimum Circuit Ampacity	Unit+ 7.5 kW	40	40	43	43	51	51	20	22	25	17	18	21
	Electric Heat 15 kW	52	58	56	62	63	69	29	31	34	23	25	27
	and (1) 0.33 HP 22.5 kW	72	81	75	84	83	92	40	42	45	32	34	36
	Power Exhaust 30 kW	91	103	95	107	103	115	51	53	57	41	43	45
	45 kW	130	148	134	152	142	160	74	76	79	59	61	64

**ELECTRICAL ACCESSORIES**

Disconnect	7.5 kW	54W56			54W56		
	15 kW	54W56			54W56		
	22.5 kW	54W56	54W57		54W56		
	30 kW	54W57			54W56		
	45 kW	54W57			54W56		

NOTE - All units have a minimum Short Circuit Current Rating (SCCR) of 5000 amps.

<sup>1</sup> Extremes of operating range are plus and minus 10% of line voltage.

<sup>2</sup> HACR type breaker or fuse.

<sup>3</sup> Refer to National or Canadian Electrical Code manual to determine wire, fuse and disconnect size requirements.

**ELECTRICAL/ELECTRIC HEAT DATA**

**10 TON**

**10 TON STANDARD EFFICIENCY (R-410A)**

**KCA/KCB120S4**

<sup>1</sup> Voltage - 60hz		208/230V - 3 Ph			460V - 3 Ph			575V - 3 Ph		
Compressor 1	Rated Load Amps	13.5			8			5		
	Locked Rotor Amps	109			59			40		
Compressor 2	Rated Load Amps	13.5			8			5		
	Locked Rotor Amps	109			59			40		
Outdoor Fan Motors (2)	Full Load Amps (total)	2.4 (4.8)			1.3 (2.6)			1 (2)		
Power Exhaust (1) 0.33 HP	Full Load Amps	2.4			1.3			1		
Service Outlet 115V GFI (amps)		15			15			20		
Indoor Blower Motor	Horsepower	2	3	5	2	3	5	2	3	5
	Full Load Amps	7.5	10.6	16.7	3.4	4.8	7.6	2.7	3.9	6.1
<sup>2</sup> Maximum Overcurrent Protection	Unit Only	50	50	60	30	30	35	20	20	25
	With (1) 0.33 HP Power Exhaust	50	60	70	30	30	35	20	20	25
<sup>3</sup> Minimum Circuit Ampacity	Unit Only	43	46	53	24	26	29	16	18	20
	With (1) 0.33 HP Power Exhaust	46	49	56	26	27	30	17	19	21

**ELECTRIC HEAT DATA**

Electric Heat Voltage			208V	240V	208V	240V	208V	240V	480V	480V	480V	600V	600V	600V
<sup>2</sup> Maximum Overcurrent Protection	Unit+ 15 kW	Electric Heat	50	60	60	60	60	70	30	30	35	25	25	30
	22.5 kW		70	80	80	90	80	90	40	40	45	35	35	35
	30 kW		90	100	100	110	100	125	50	60	60	40	45	45
	45 kW		150	150	150	150	150	175	80	80	80	60	60	70
<sup>3</sup> Minimum Circuit Ampacity	Unit+ 15 kW	Electric Heat	49	55	53	59	60	66	27	29	33	22	23	26
	22.5 kW		69	78	72	81	80	89	39	40	44	31	32	35
	30 kW		88	100	92	104	100	112	50	52	55	40	41	44
	45 kW		127	145	131	149	139	157	72	74	78	58	60	62
<sup>2</sup> Maximum Overcurrent Protection	Unit+ 15 kW	Electric Heat	60	60	60	70	70	70	30	35	35	25	25	30
	22.5 kW		80	90	80	90	90	100	40	45	45	35	35	40
	30 kW	and (1) 0.33 HP	100	110	100	110	110	125	60	60	60	45	45	45
	45 kW	Power Exhaust	150	150	150	175	150	175	80	80	80	60	70	70
<sup>3</sup> Minimum Circuit Ampacity	Unit+ 15 kW	Electric Heat	52	58	56	62	63	69	29	31	34	23	25	27
	22.5 kW		72	81	75	84	83	92	40	42	45	32	34	36
	30 kW	and (1) 0.33 HP	91	103	95	107	103	115	51	53	57	41	43	45
	45 kW	Power Exhaust	130	148	134	152	142	160	74	76	79	59	61	64
	60 kW		138	157	142	161	149	169	79	80	84	63	64	67

**ELECTRICAL ACCESSORIES**

Disconnect	15 kW	54W56	54W56	54W56
	22.5 kW	54W57	54W56	54W56
	30 kW	54W57	54W56	54W56
	45 kW	54W57	54W56	54W56
	60 kW	Not Available	54W56	54W56

NOTE - All units have a minimum Short Circuit Current Rating (SCCR) of 5000 amps.

<sup>1</sup> Extremes of operating range are plus and minus 10% of line voltage.

<sup>2</sup> HACR type breaker or fuse.

<sup>3</sup> Refer to National or Canadian Electrical Code manual to determine wire, fuse and disconnect size requirements.

**ELECTRICAL/ELECTRIC HEAT DATA**

**10 TON**

**10 TON HIGH EFFICIENCY (R-410A)**

**KCA120H4**

<sup>1</sup> Voltage - 60hz		208/230V - 3 Ph			460V - 3 Ph			575V - 3 Ph		
Compressor 1	Rated Load Amps	13.5			8			5		
	Locked Rotor Amps	109			59			40		
Compressor 2	Rated Load Amps	13.5			8			5		
	Locked Rotor Amps	109			59			40		
Outdoor Fan Motors (2)	Full Load Amps (total)	2.4 (4.8)			1.3 (2.6)			1 (2)		
Power Exhaust (1) 0.33 HP	Full Load Amps	2.4			1.3			1		
Service Outlet 115V GFI (amps)		15			15			20		
Indoor Blower Motor	Horsepower	2	3	5	2	3	5	2	3	5
	Full Load Amps	7.5	10.6	16.7	3.4	4.8	7.6	2.7	3.9	6.1
<sup>2</sup> Maximum Overcurrent Protection	Unit Only	50	50	60	30	30	35	20	20	25
	With (1) 0.33 HP Power Exhaust	50	60	70	30	30	35	20	20	25
<sup>3</sup> Minimum Circuit Ampacity	Unit Only	43	46	53	24	26	29	16	18	20
	With (1) 0.33 HP Power Exhaust	46	49	56	26	27	30	17	19	21

**ELECTRIC HEAT DATA**

Electric Heat Voltage		208V	240V	208V	240V	208V	240V	480V	480V	480V	600V	600V	600V
<sup>2</sup> Maximum Overcurrent Protection	Unit+ 15 kW	50	60	60	60	60	70	30	30	35	25	25	30
	Electric Heat 22.5 kW	70	80	80	90	80	90	40	40	45	35	35	35
	30 kW	90	100	100	110	100	125	50	60	60	40	45	45
	45 kW	150	150	150	150	150	175	80	80	80	60	60	70
<sup>3</sup> Minimum Circuit Ampacity	Unit+ 15 kW	49	55	53	59	60	66	27	29	33	22	23	26
	Electric Heat 22.5 kW	69	78	72	81	80	89	39	40	44	31	32	35
	30 kW	88	100	92	104	100	112	50	52	55	40	41	44
	45 kW	127	145	131	149	139	157	72	74	78	58	60	62
<sup>2</sup> Maximum Overcurrent Protection	Unit+ 15 kW	60	60	60	70	70	70	30	35	35	25	25	30
	Electric Heat 22.5 kW	80	90	80	90	90	100	40	45	45	35	35	40
	and (1) 0.33 HP 30 kW	100	110	100	110	110	125	60	60	60	45	45	45
	Power Exhaust 45 kW	150	150	150	175	150	175	80	80	80	60	70	70
<sup>3</sup> Minimum Circuit Ampacity	Unit+ 15 kW	52	58	56	62	63	69	29	31	34	23	25	27
	Electric Heat 22.5 kW	72	81	75	84	83	92	40	42	45	32	34	36
	and (1) 0.33 HP 30 kW	91	103	95	107	103	115	51	53	57	41	43	45
	Power Exhaust 45 kW	130	148	134	152	142	160	74	76	79	59	61	64
	60 kW	138	157	142	161	149	169	79	80	84	63	64	67

**ELECTRICAL ACCESSORIES**

Disconnect	15 kW	54W56			54W56		
	22.5 kW	54W56	54W57		54W56		
	30 kW	54W57			54W56		
	45 kW	54W57			54W56		
	60 kW	Not Available			54W56	N/A	54W56

NOTE - All units have a minimum Short Circuit Current Rating (SCCR) of 5000 amps.

<sup>1</sup> Extremes of operating range are plus and minus 10% of line voltage.

<sup>2</sup> HACR type breaker or fuse.

<sup>3</sup> Refer to National or Canadian Electrical Code manual to determine wire, fuse and disconnect size requirements.

**ELECTRICAL/ELECTRIC HEAT DATA**

**12.5 TON**

**12.5 TON STANDARD EFFICIENCY (R-410A)**

**KCB150S4**

<sup>1</sup> Voltage - 60hz		208/230V - 3 Ph			460V - 3 Ph			575V - 3 Ph		
Compressor 1	Rated Load Amps	19.6			8.2			6.6		
	Locked Rotor Amps	136			66.1			55.3		
Compressor 2	Rated Load Amps	22.4			10.6			7.7		
	Locked Rotor Amps	149			75.0			54.0		
Outdoor Fan Motors (2)	Full Load Amps (total)	3 (6)			1.5 (3)			1.2 (2.4)		
Power Exhaust (1) 0.33 HP	Full Load Amps	2.4			1.3			1		
Service Outlet 115V GFI (amps)		15			15			20		
Indoor Blower Motor	Horsepower	2	3	5	2	3	5	2	3	5
	Full Load Amps	7.5	10.6	16.7	3.4	4.8	7.6	2.7	3.9	6.1
<sup>2</sup> Maximum Overcurrent Protection	Unit Only	80	80	90	35	35	40	25	30	30
	With (1) 0.33 HP Power Exhaust	80	80	90	35	40	40	30	30	30
<sup>3</sup> Minimum Circuit Ampacity	Unit Only	62	65	71	28	30	33	22	23	25
	With (1) 0.33 HP Power Exhaust	64	67	73	30	31	34	23	24	26

**ELECTRIC HEAT DATA**

Electric Heat Voltage			208V	240V	208V	240V	208V	240V	480V	480V	480V	600V	600V	600V
<sup>2</sup> Maximum Overcurrent Protection	Unit+ 15 kW	Electric Heat	70	70	80	80	80	80	30	30	35	25	25	30
	22.5 kW		70	80	80	90	80	90	40	40	45	35	35	35
	30 kW		90	100	100	110	100	125	50	60	60	40	45	45
	45 kW		150	150	150	150	150	175	80	80	80	60	60	70
<sup>3</sup> Minimum Circuit Ampacity	Unit+ 15 kW	Electric Heat	58	58	61	61	67	67	27	29	33	22	23	26
	22.5 kW		69	78	72	81	80	89	39	40	44	31	32	35
	30 kW		88	100	92	104	100	112	50	52	55	40	41	44
	45 kW		127	145	131	149	139	157	72	74	78	58	60	62
<sup>2</sup> Maximum Overcurrent Protection	Unit+ 15 kW	Electric Heat	70	70	80	80	80	80	30	35	35	25	25	30
	22.5 kW		80	90	80	90	90	100	40	45	45	35	35	40
	30 kW	and (1) 0.33 HP	100	110	100	110	110	125	60	60	60	45	45	45
	45 kW	Power Exhaust	150	150	150	175	150	175	80	80	80	60	70	70
<sup>3</sup> Minimum Circuit Ampacity	Unit+ 15 kW	Electric Heat	60	60	64	64	70	70	29	31	34	23	25	27
	22.5 kW		72	81	75	84	83	92	40	42	45	32	34	36
	30 kW	and (1) 0.33 HP	91	103	95	107	103	115	51	53	57	41	43	45
	45 kW	Power Exhaust	130	148	134	152	142	160	74	76	79	59	61	64
	60 kW		138	157	142	161	149	169	79	80	84	63	64	67

**ELECTRICAL ACCESSORIES**

Disconnect	15 kW	54W56	54W56	54W56
	22.5 kW	54W57	54W56	54W56
	30 kW	54W57	54W56	54W56
	45 kW	Not Available	54W56	54W56
	60 kW	Not Available	54W56	54W56

NOTE - All units have a minimum Short Circuit Current Rating (SCCR) of 5000 amps.

<sup>1</sup> Extremes of operating range are plus and minus 10% of line voltage.

<sup>2</sup> HACR type breaker or fuse.

<sup>3</sup> Refer to National or Canadian Electrical Code manual to determine wire, fuse and disconnect size requirements.

## ELECTRIC HEAT CAPACITIES

Volts Input	7.5 kW			15 kW			22.5 kW			30 kW			45 kW			60 kW		
	kW Input	Btuh Output	No. of Stages	kW Input	Btuh Output	No. of Stages	kW Input	Btuh Output	No. of Stages	kW Input	Btuh Output	No. of Stages	kW Input	Btuh Output	No. of Stages	kW Input	Btuh Output	No. of Stages
208	5.6	19,100	1	11.3	38,600	1	16.9	57,700	2	22.5	76,800	2	33.8	115,300	2	45.0	153,600	2
220	6.3	21,500	1	12.6	43,000	1	18.9	64,500	2	25.2	86,000	2	37.8	129,000	2	50.4	172,000	2
230	6.9	23,600	1	13.8	47,100	1	20.7	70,700	2	27.5	93,900	2	41.3	141,000	2	55.1	188,000	2
240	7.5	25,600	1	15.0	51,200	1	22.5	76,800	2	30.0	102,400	2	45.0	153,600	2	60.0	204,800	2
440	6.9	21,500	1	12.6	43,000	1	18.9	64,500	2	25.2	86,000	2	37.8	129,000	2	50.4	172,000	2
460	6.9	23,600	1	13.8	47,100	1	20.7	70,700	2	27.5	93,900	2	41.3	141,000	2	55.1	188,000	2
480	7.5	25,600	1	15.0	51,200	1	22.5	76,800	2	30.0	102,400	2	45.0	153,600	2	60.0	204,800	2
550	6.3	21,500	1	12.6	43,000	1	18.9	64,500	2	25.2	86,000	2	37.8	129,000	2	50.4	172,000	2
575	6.9	23,600	1	13.8	47,100	1	20.7	70,700	2	27.5	93,900	2	41.3	141,000	2	55.1	188,000	2
600	7.5	25,600	1	15.0	51,200	1	22.5	76,800	2	30.0	102,400	2	45.0	153,600	2	60.0	204,800	2

# KCA/KCB PARTS ARRANGEMENT

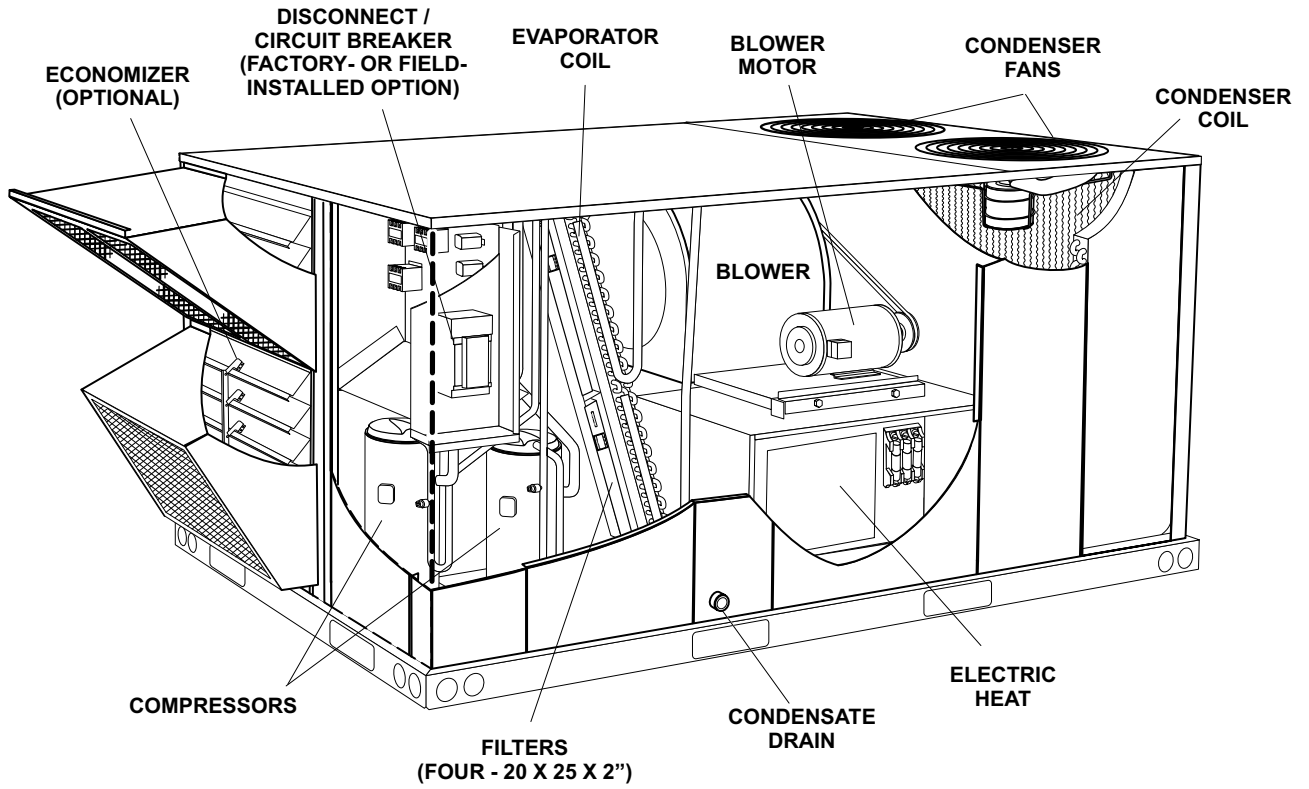


FIGURE 1

## KCA/KCB CONTROL BOX - Y, G, J- VOLT UNITS

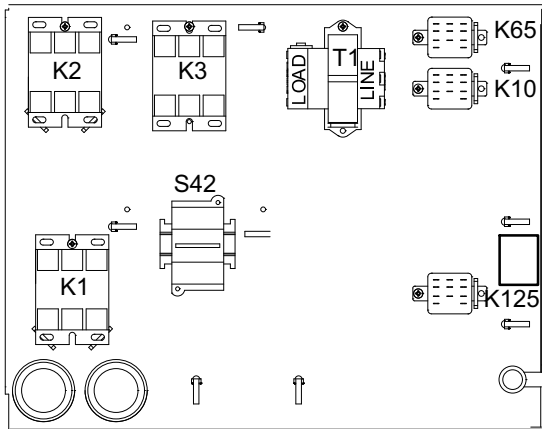


FIGURE 2

## KCA/KCB CONTROL BOX - M VOLT CE UNITS

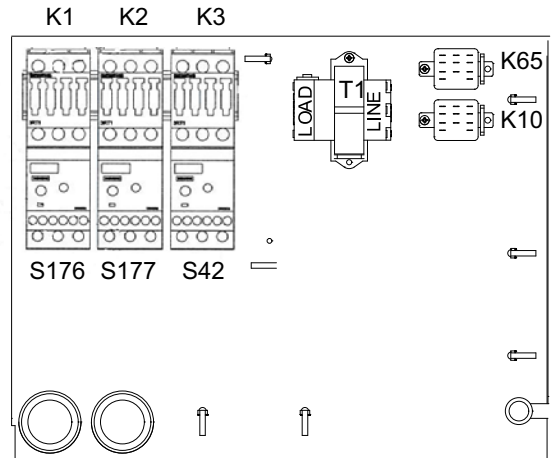


FIGURE 3

## I-UNIT COMPONENTS

All 7.5 through 12.5 ton (26.3 through 44 kW) units are configured to order units (CTO). The KCA/KCB unit components are shown in figure 1. All units come standard with removable unit panels. All L1, L2 and L3 wiring is color-coded: L1 is red, L2 is yellow and L3 is blue.

### A-Control Box Components

KCA/KCB control box components are shown in figure 2 and 3. The control box is located in the upper portion of the compressor compartment.

#### 1-Disconnect Switch S48 or CB10 (CB10 field-installed only)

All units may be equipped with an optional disconnect switch S48 or circuit breaker CB10. S48 and CB10 are toggle switches, which can be used by the service technician to disconnect power to the unit.

#### 2-Control Transformer T1 all units

All use a single line voltage to 24VAC transformer mounted in the control box. Transformer supplies power to control circuits in the unit. The transformer is rated at 70VA and is protected by a 3.5 amp circuit breaker (CB8). The 208/230 (Y) voltage transformers use two

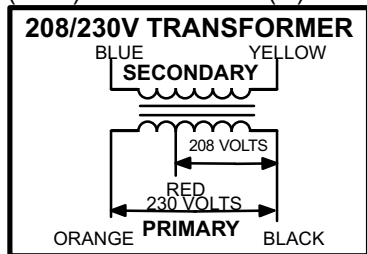


FIGURE 4

primary voltage taps as shown in figure 4, while 460 (G) and 575 (J) voltage transformers use a single primary voltage tap.

#### 3-Terminal Strip TB1

All indoor thermostat wires are connected to terminal block TB1 located in the control area. For thermostats without “occupied “ and “unoccupied” modes, a factory-installed jumper across terminals R and OC should be in place.

#### 4-Condenser Fan Capacitors C1 & C2

Fan capacitors C1 and C2 assist in the start up of condenser fans B4 and B5. Ratings will be on side of capacitor or outdoor fan motor nameplate.

#### 5-Compressor Contactor K1 & K2

All compressor contactors are three-pole-double-break contactors with 24VAC coils. In all KCA/KCB units, K1 and K2 energize compressors B1 and B2 in response to thermostat demand. On CE M-voltage units, the contactor is CE approved by the manufacturer (Siemens). See figure 5.

#### 6-Condenser Fan Relay K10

Outdoor fan relay K10 is a DPDT relay with a 24VAC coil. K10 energizes condenser fans B4 and B5.

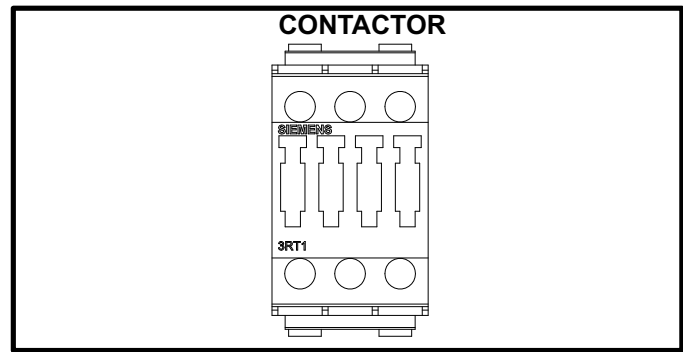


FIGURE 5

#### 7-Blower Contactor K3

Blower contactor K3, used in all units, is a three-pole-double-break contactor with a 24VAC coil used to energize the indoor blower motor B3 in response to blower demand. K3 is energized by a thermostat cooling demand. On M-voltage CE units, the contactor is CE approved by the manufacturer (Siemens). See figure 5.

#### 8-Power Exhaust Relay K65 (PED units)

Power exhaust relay K65 is a DPDT relay with a 24VAC coil. K65 is used in all KCA/KCB units equipped with the optional power exhaust dampers. K65 is energized by the economizer enthalpy control A6, after the economizer dampers reach 50% open (adjustable) When K65 closes, exhaust fan B10 is energized.

#### 9-Blower Motor Overload Relay Switch (S42)

The blower motor overload relay is used in all units equipped with high-efficiency motors. The relay (S42) is connected in line with the blower motor to monitor the current flow to the motor. When the relay senses an overload condition, a set of normally closed contacts open to de-energize 24VAC power to T1 transformer. Non-CE units are equipped with a relay manufactured by Telemecanique figure 7 or Siemens figure 8. M-voltage CE units are equipped with a relay manufactured by Siemens. See figure 6.

#### 10-Compressor Overload Relays S176, S177 (M-volt CE units)

Relays are wired in series with the appropriate compressor contactor and monitor the current flow to the compressor motor. When the relay senses an overload condition, normally closed contacts open to de-energize the compressor. Relays are manufactured by Siemens; see fig. 6.

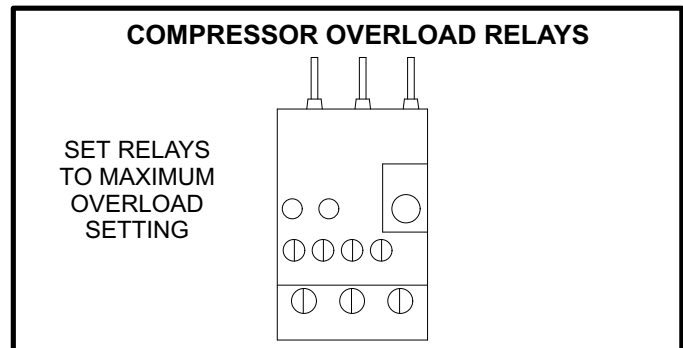
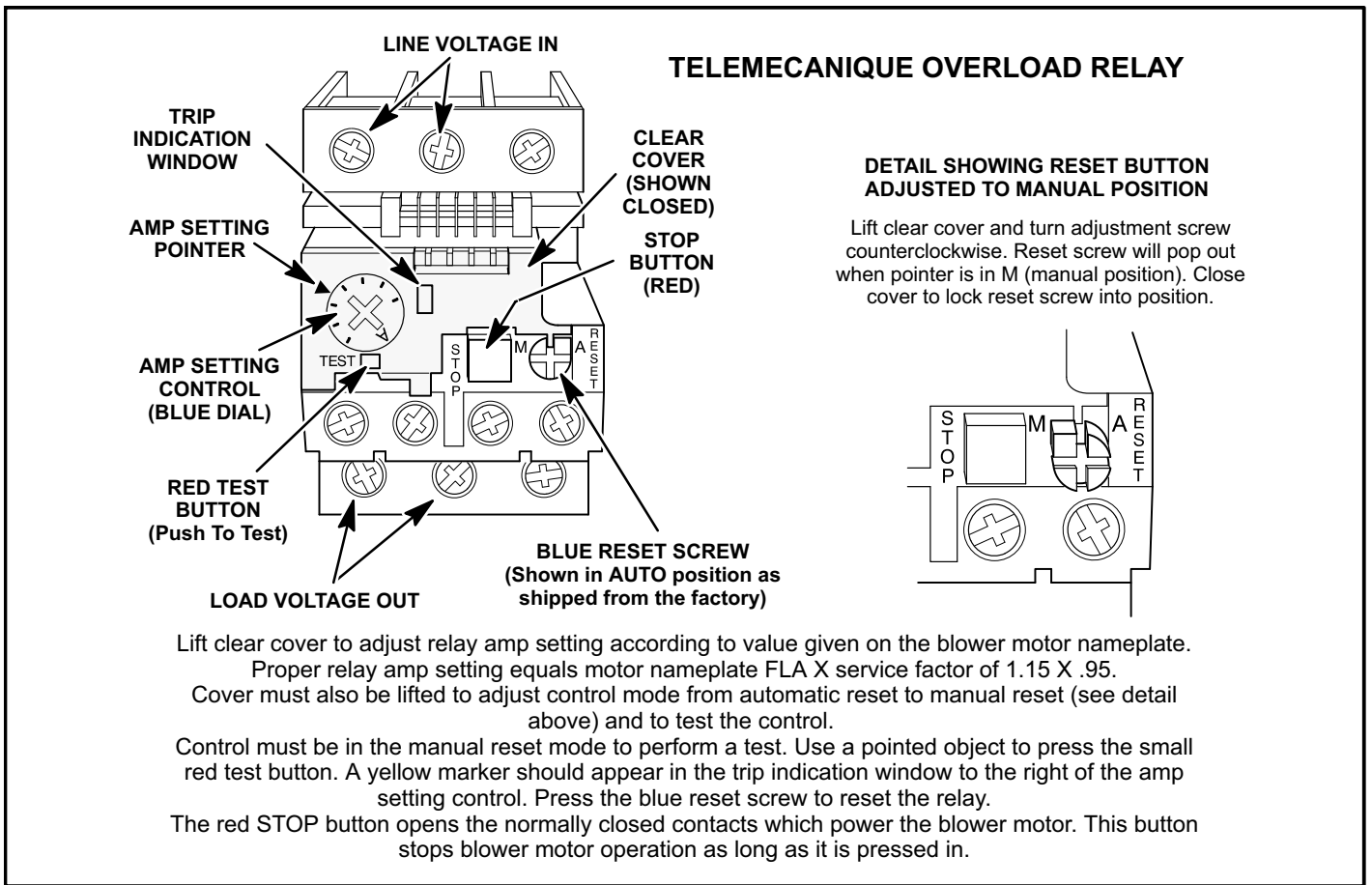
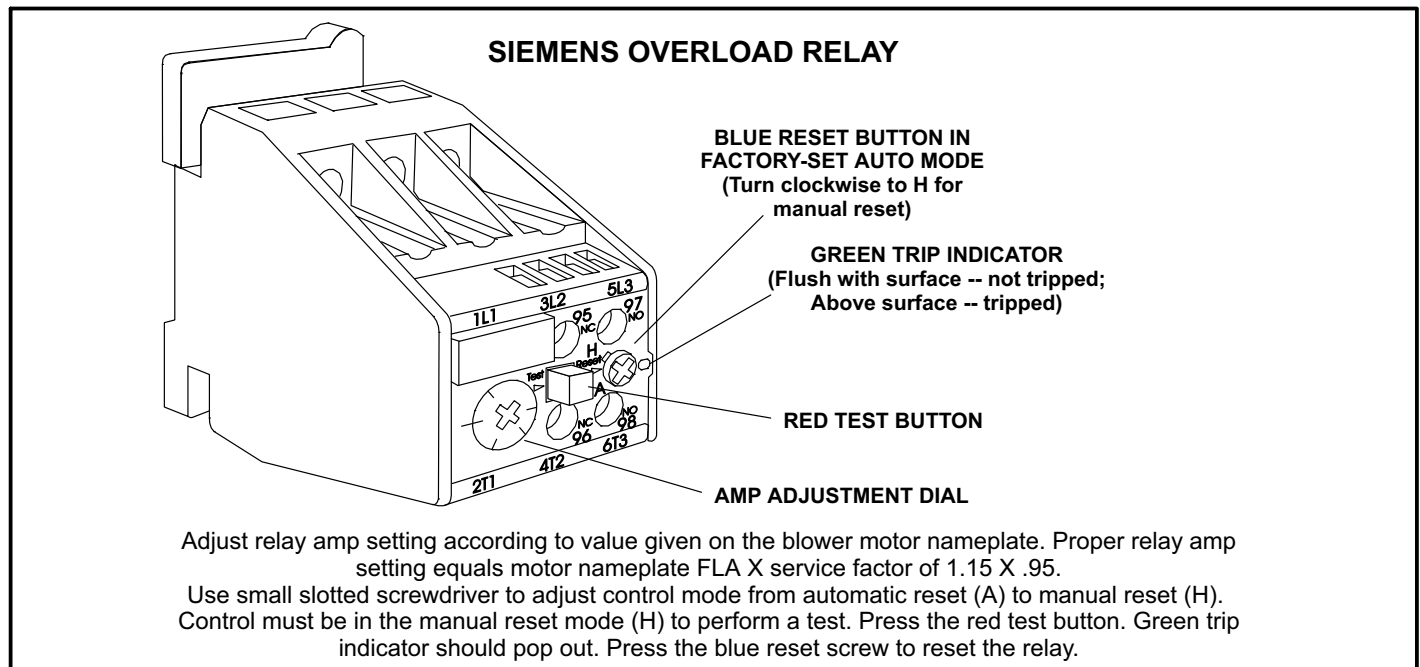


FIGURE 6



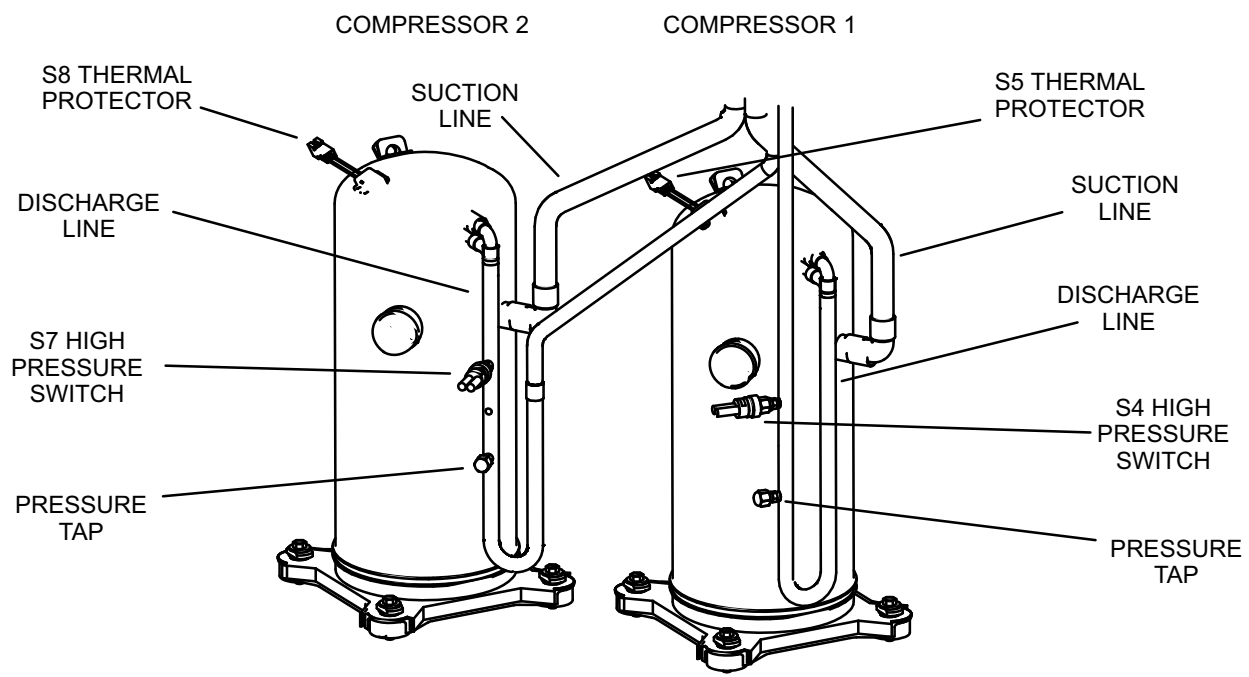
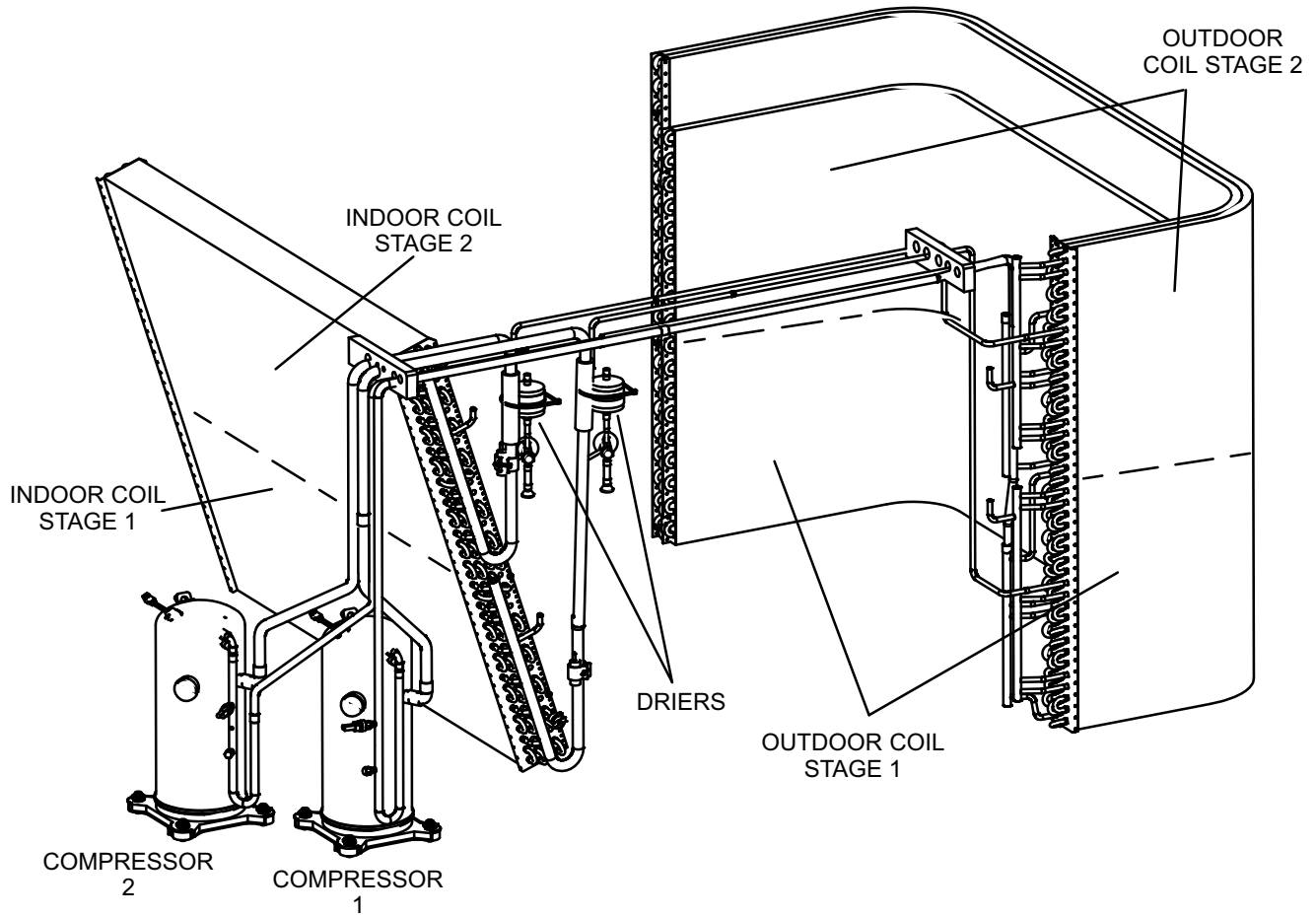


**FIGURE 7**



**FIGURE 8**

**KCA/KCB092,102, 120, 150 PLUMBING AND COMPRESSOR CIRCUIT DETAIL**



**FIGURE 9**

## B-Cooling Components

All units use independent cooling circuits consisting of separate compressors, condenser coils and evaporator coils. See figure 9. Two draw-through type condenser fans are used in KCA/KCB092/150 units. All units are equipped with belt-drive blowers which draw air across the evaporator coil during unit operation.

Cooling may be supplemented by a factory- or field-installed economizer. The evaporators are slab-type and are stacked. Each evaporator uses a thermostatic expansion valve as the primary refrigerant metering device. Each evaporator is also equipped with enhanced fins and rifled tubing.

In all units, each compressor is protected by S49 and S50 freezestats and S4 and S7 high pressure switches (on each evaporator). Low ambient switches (S11, S84) are available as an option for additional compressor protection. On 150 units, each compressor is protected by a crankcase heater.

## 1-Compressors B1 and B2

All KCA/KCB092/150 units use two scroll compressors. Compressor capacity may vary from stage to stage. In all cases, the capacity of each compressor is added to reach the total capacity of the unit. See "SPECIFICATIONS" and "ELECTRICAL DATA" (table of contents) or compressor nameplate for compressor specifications.

### WARNING

**Electrical shock hazard. Compressor must be grounded. Do not operate without protective cover over terminals. Disconnect power before removing protective cover. Discharge capacitors before servicing unit. Failure to follow these precautions could cause electrical shock resulting in injury or death.**

Each compressor is energized by a corresponding compressor contactor.

*NOTE - Refer to the wiring diagram section for specific unit operation.*

### IMPORTANT

**Some scroll compressors have an internal vacuum protector that will unload scrolls when suction pressure goes below 20 psig. A hissing sound will be heard when the compressor is running unloaded. Protector will reset when low pressure in system rises above 40 psig. DO NOT REPLACE COMPRESSOR.**

## 2-Thermal Protectors S5, S8

Some compressors have thermal protectors located on top of the compressor. The protectors open at  $248^{\circ}\text{F} \pm 9^{\circ}\text{F}$  ( $120^{\circ}\text{C} \pm 5^{\circ}\text{C}$ ) and close at  $169^{\circ}\text{F} \pm 18^{\circ}\text{F}$  ( $76^{\circ}\text{C} \pm 10^{\circ}\text{C}$ ).

## 3-Freezestats S49 and S50

Each unit is equipped with a low temperature switch (freezestat) located on a return bend of each evaporator coil. S49 (first circuit) and S50 (second circuit) are located on the corresponding evaporator coils.

Freezestats are wired in series with compressor contactors. Each freezestat is a SPST N.C. auto-reset switch which opens at  $29^{\circ}\text{F} \pm 3^{\circ}\text{F}$  ( $-1.7^{\circ}\text{C} \pm 1.7^{\circ}\text{C}$ ) on a temperature drop and closes at  $58^{\circ}\text{F} \pm 4^{\circ}\text{F}$  ( $14.4^{\circ}\text{C} \pm 2.2^{\circ}\text{C}$ ) on a temperature rise. To prevent coil icing, freezestats open during compressor operation to temporarily disable the respective compressor until the coil temperature rises.

If the freezestats are tripping frequently due to coil icing, check the airflow/filters, economizer position and unit charge before placing the unit back into operation. Make sure to eliminate conditions which might promote evaporator ice buildup.

## 4-High Pressure Switches S4 and S7

The high pressure switch is a manually reset SPST N.C. switch which opens on a pressure rise.

S4 (first circuit) and S7 (second circuit) are located in the compressor discharge line and are wired in series with the respective compressor contactor coils.

When discharge pressure rises to  $640 \pm 10$  psig ( $4413 \pm 69$  kPa) (indicating a problem in the system) the switch opens and the respective compressor is de-energized (the economizer can continue to operate).

## 5-Low Ambient Switches S11 & S84 (optional)

The low ambient switch is an auto-reset SPST N.O. pressure switch which allows for mechanical cooling operation at low outdoor temperatures. In all models a switch is located in each liquid line prior to the indoor coil section.

In the KCA/KCB092/150, S11 and S84 are wired in parallel with outdoor fan relay K10.

When liquid pressure rises to  $450 \pm 10$  psig ( $3102 \pm 69$  kPa), the switch closes and the condenser fans are energized. When discharge pressure in both refrigerant circuits drops to  $240 \pm 10$  psig ( $1655 \pm 69$  kPa), the switches open and the condenser fans are de-energized. This intermittent fan operation results in higher evaporating temperature allowing the system to operate without icing the evaporator coil and losing capacity.

## 6-Crankcase Heaters HR1, HR2

150S units use insertion type heaters. Heater HR1 is installed around compressor B1 and heater HR2 is installed around compressor B2. Crankcase heater wattage varies by compressor manufacturer.

## C-Blower Compartment

The blower compartment in all KCA/KCB092/150S units is located between the evaporator coil and the condenser coil section. The blower assembly is accessed by disconnecting the blower motor. See *Blower Access* in the Operation/ Adjustment section.

### 1-Blower Wheels

All KCA/KCB092/150 units have one 15 in. x 15 in. (381 mm x 381 mm) blower wheel.

### 2-Indoor Blower Motor B3

All units use three-phase single-speed blower motors. CFM adjustments are made by adjusting the motor pulley (sheave). Motors are equipped with sealed ball bearings. All motor specifications are listed in the SPECIFICATIONS (table of contents) in the front of this manual. Units may be equipped with motors manufactured by various manufacturers, therefore electrical FLA and LRA specifications will vary. See unit rating plate for information specific to your unit.

## Operation and Adjustments

### A-Three Scroll Compressor Voltage Phasing

Three phase scroll compressors must be phased sequentially to ensure correct compressor and blower rotation and operation. Compressor and blower are wired in phase at the factory. Power wires are color-coded as follows: line 1-red, line 2-yellow, line 3-blue.

- 1- Observe suction and discharge pressures and blower rotation on unit start-up.

If pressure differential is not observed or blower rotation is not correct:

- 2- Suction pressure must drop, discharge pressure must rise, and blower rotation must match rotation marking.
- 3- Disconnect all remote electrical power supplies.
- 4- Reverse any two field-installed wires connected to the line side of K3, TB2 or F4. Do not reverse wires at blower contactor or compressors.

- 5- Make sure the connections are tight.

Discharge and suction pressures should operate at their normal start-up ranges.

**Supply Air Inverter Units** - Units are equipped with a phase monitor located in the control compartment. The phase monitor will detect the phasing of incoming power. If the incoming power is out of phase or if any of the three phases are lost, the indicating LED on the phase monitor will turn red and the unit will not start. In normal operation with correct incoming power phasing, the LED will be green.

### B-Blower Operation

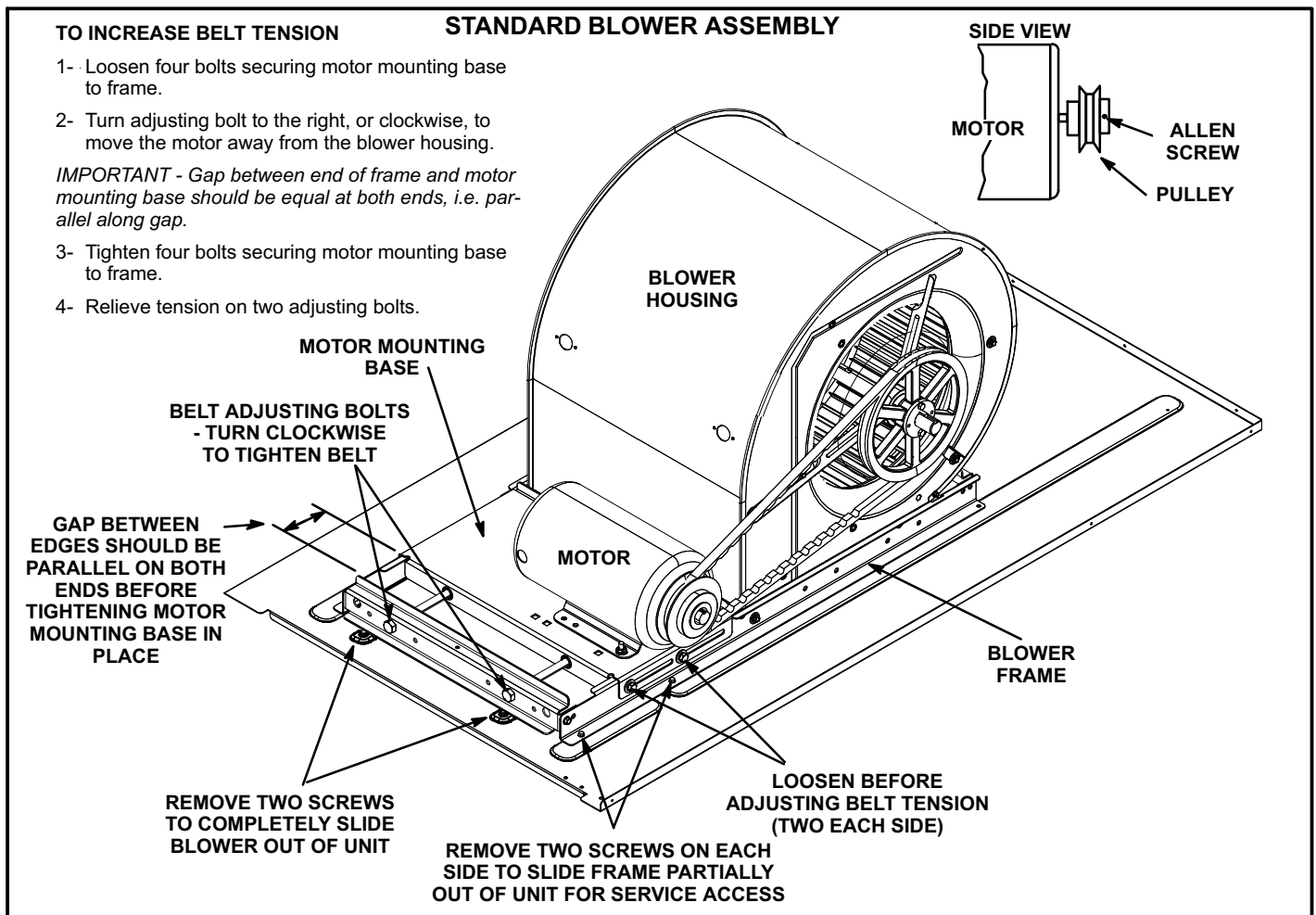
Initiate blower demand at thermostat according to instructions provided with thermostat. Unit will cycle on thermostat demand. The following steps apply to applications using a typical electro-mechanical thermostat.

- 1- Blower operation is manually set at the thermostat sub-base fan switch. With fan switch in **ON** position, blowers will operate continuously.
- 2- With fan switch in **AUTO** position, the blowers will cycle with demand. Blowers and entire unit will be off when system switch is in **OFF** position.

### C-Blower Access

The blower assembly is secured to a sliding frame which allows the blower motor to be pulled out of the unit. See figure 10.

- 1- Loosen the reusable wire tie which secures the blower wiring to the blower motor mounting plate.
- 2- Remove and retain screws on either side of sliding frame. Pull frame toward outside of unit.
- 3- Slide frame back into original position when finished servicing. Reattach the blower wiring in the previous location on the blower motor base using the wire tie.
- 4- Replace retained screws on either side of the sliding frame.



**FIGURE 10**

**D-Determining Unit CFM**

*IMPORTANT - Units equipped with an inverter are factory-set to run the blower at full speed when there is a blower (G) demand without a heating or cooling demand. Use the following procedure to adjust motor pulley to deliver the full load cooling or heating CFM. See Inverter Start-Up section to set blower CFM for all modes once the motor pulley is set.*

- 1- The following measurements must be made with a dry indoor coil. Run blower without a cooling demand. Measure the indoor blower shaft RPM. Air filters must be in place when measurements are taken.
  - 2- With all access panels in place, measure static pressure external to unit (from supply to return). Blower performance data is based on static pressure readings taken in locations shown in figure 11.
- Note - Static pressure readings can vary if not taken where shown.*
- 3- Referring to page 13, 14, or 15, use static pressure and RPM readings to determine unit CFM. Use pages 16 and 17 when installing units with any of the optional accessories listed.

- 4- The blower RPM can be adjusted at the motor pulley. Loosen Allen screw and turn adjustable pulley clockwise to increase CFM. Turn counterclockwise to decrease CFM. See figure 10. Do not exceed minimum and maximum number of pulley turns as shown in table 1.

**TABLE 1  
MINIMUM AND MAXIMUM PULLEY ADJUSTMENT**

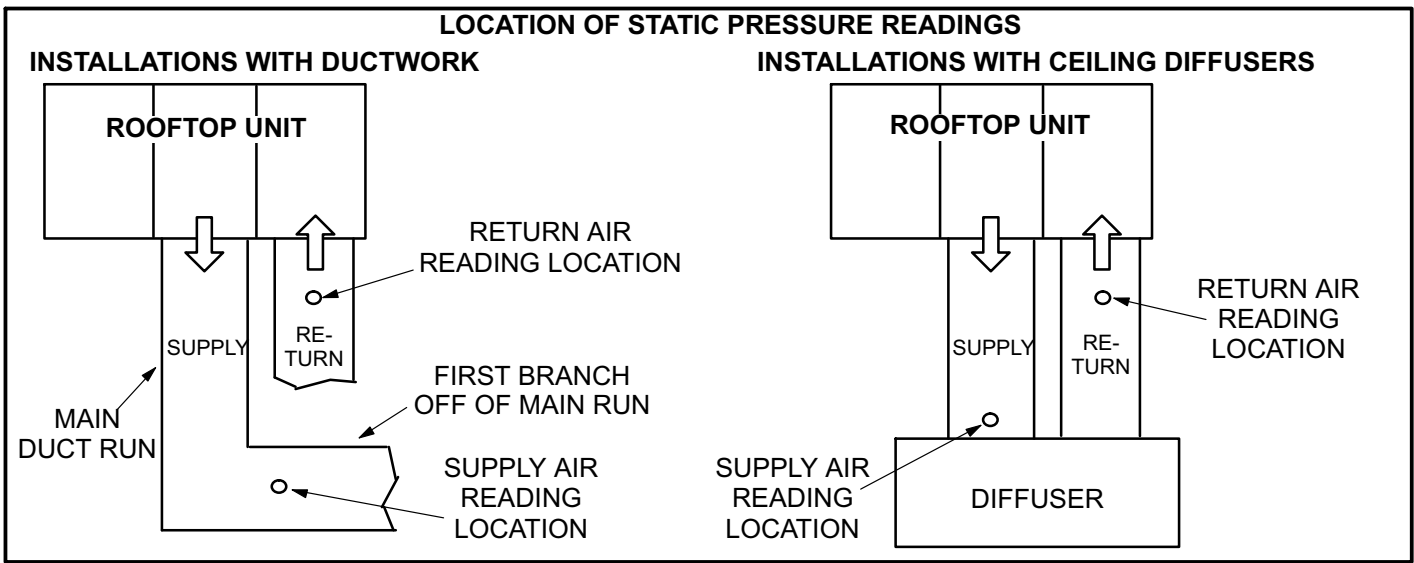
Belt	Minimum Turns Open	Maximum Turns Open
A Section	0	5
B Section	1*	6

\*No minimum number of turns open when B belt is used on pulleys 6" O.D. or larger.

**E-Blower Belt Adjustment**

Maximum life and wear can be obtained from belts only if proper pulley alignment and belt tension are maintained. Tension new belts after a 24-48 hour period of operation. This will allow belt to stretch and seat in the pulley grooves. Make sure blower and motor pulleys are aligned as shown in figure 12.

- 1- Loosen four bolts securing motor base to mounting frame. See figure 10.



**FIGURE 11**

**2- To increase belt tension -**

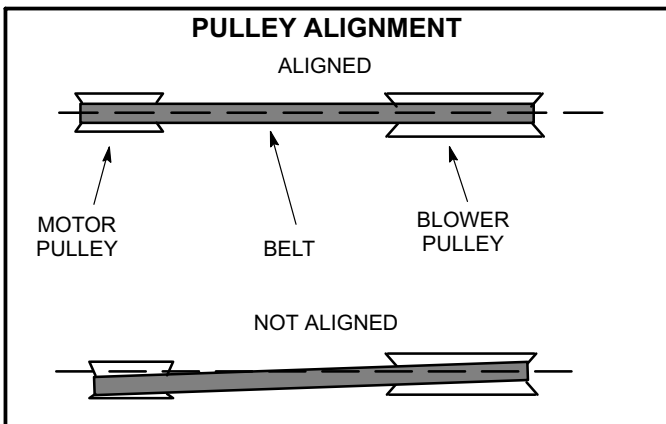
Turn both adjusting bolts to the right, or clockwise, to move the motor outward and tighten the belt. This increases the distance between the blower motor and the blower housing.

**To loosen belt tension -**

Turn the adjusting bolts to the left, or counterclockwise to loosen belt tension.

**IMPORTANT -** Align top edges of blower motor base and mounting frame base parallel before tightening two bolts on the other side of base. Motor shaft and blower shaft must be parallel.

**3- Tighten two bolts on each side of the motor mounting base. This secures the mounting base to the frame.**

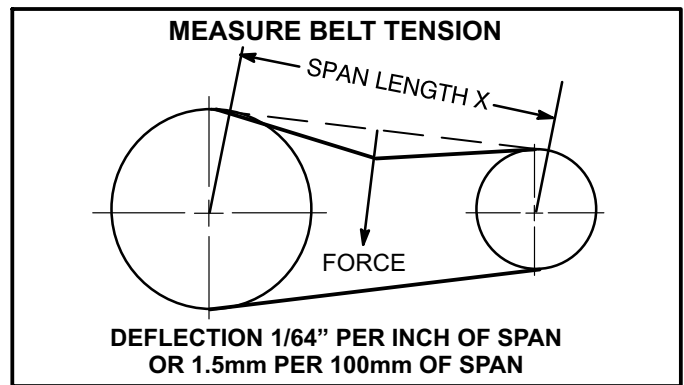


**FIGURE 12**

**F-Check Belt Tension**

Overtensioning belts shortens belt and bearing life. Check belt tension as follows:

**1- Measure span length X. See figure 13.**



**FIGURE 13**

**2- Apply perpendicular force to center of span (X) with enough pressure to deflect belt 1/64" for every inch of span length or 1.5mm per 100mm of span length.**

Example: Deflection distance of a 40" span would be 40/64" or 5/8".

Example: Deflection distance of a 400mm span would be 6mm.

**3- Measure belt deflection force. For a new 2 and 3hp belt, the deflection force should be 5.0-7.0 lbs. (35-48kPa). For a new 5hp belt, the deflection force should be 7-10lbs. (48-69kPa).**

A force below these values indicates an undertensioned belt. A force above these values indicates an overtensioned belt.

**G-Field-Furnished Blower Drives**

For field-furnished blower drives, use pages 13 through 17 to determine BHP and RPM required. Reference table 2 for drive component manufacturer's numbers.

**TABLE 2  
MANUFACTURER'S NUMBERS**

DRIVE NO.	DRIVE COMPONENTS					
	ADJUSTABLE SHEAVE		FIXED SHEAVE		BELT	
	BROWNING NO.	OEM PART NO.	BROWNING NO.	OEM PART NO.	BROWNING NO.	OEM PART NO.
1	1VP34x7/8	31K6901	AK61x1	100244-20	AX54	100245-25
2	1VP40x7/8	79J0301	AK59x1	31K6801	AX55	100245-26
3	1VP34x7/8	31K6901	AK46x1	100244-17	AX52	100245-33
4	1VP44x7/8	53J9601	AK74x1	100244-21	AX58	100245-34
5	1VP50x7/8	98J0001	AK69x1	37L4701	AX58	100245-34
6	1VP50x7/8	98J0001	AK64x1	12L2501	AX57	100245-28
10	1VP50x1-1/8	P-8-1977	BK77x1	49K4001	BX59	59A5001
11	1VP50x1-1/8	P-8-1977	BK67x1	100244-24	BX57	78L5301
12	1VP50x1-1/8	P-8-1977	BK62x1	100244-23	BX56	100245-11

## D-Optional Electric Heat Components

Table 3 shows electric heat fuse ratings. See Options/Accessories section (see table of contents) for KCA/KCB to EHA match-ups. See Electrical/Electric Heat Data section (see table of contents) of this manual for electrical ratings and capacities. All electric heat sections consist of electric heating elements exposed directly to the air stream. See figure 15. EHA parts arrangement is shown in figures 15 and 16. Multiple-stage elements are sequenced on and off in response to thermostat demand.

### 1-Contactors K15, K16

Contactors K15 and K16 are three-pole double-break contactors located on the electric heat vestibule. All contactors are equipped with a 24VAC coil. The coils in the K15 and K16 contactors are energized by a W2 thermostat demand, K9, and DL2. Contactor K15 energizes the first stage heating elements, while K16 energizes the second stage heating elements. On M-volt units, contactors are CE approved by manufacturer (Siemens). See figure 5.

### 2-High Temperature Limits S15 (Primary)

S15 is a SPST normally closed auto-reset thermostat located on the back panel of the electric heat section below the heating elements. S15 is the high temperature limit for the electric heat section. When S15 opens, indicating a problem in the system, contactor K15 is de-energized. When K15 is de-energized, first stage and all subsequent stages of heat are de-energized. For EHA102/150 units, the electric heat section thermostat is factory set to open at  $170^{\circ}\text{F} \pm 5^{\circ}\text{F}$  ( $76^{\circ}\text{C} \pm 2.8^{\circ}\text{C}$ ) on a temperature rise and automatically reset at  $130^{\circ}\text{F} \pm 6^{\circ}\text{F}$  ( $54.4^{\circ}\text{C} \pm 3.3^{\circ}\text{C}$ ) on a temperature fall. For EHA100 units, the electric heat section thermostat is factory set to open at  $160^{\circ}\text{F} \pm 5^{\circ}\text{F}$  ( $71.0^{\circ}\text{C} \pm 2.8^{\circ}\text{C}$ ) on a temperature rise and automatically reset at  $120^{\circ}\text{F} \pm$

$6^{\circ}\text{F}$  ( $49.0^{\circ}\text{C} \pm 3.3^{\circ}\text{C}$ ) on a temperature fall. The thermostat is not adjustable.

### 3-High Temperature Limit S20, S157, S158, S15, S160 & S161 (Secondary)

Limits are SPST normally closed manual-reset thermostat. Like the primary temperature limit, S20 is wired in series with the first stage contactor coil (K15) and second stage contactor coil (K16). When S20 opens, contactors (K15, K16) are de-energized. When the contactors are de-energized, first stage and all subsequent stages of heat are de-energized. The thermostat is factory set to open at  $220^{\circ}\text{F} \pm 6^{\circ}\text{F}$  ( $104^{\circ}\text{C} \pm 3.3^{\circ}\text{C}$ ) on a temperature rise and can be manually reset when temperature falls below  $160^{\circ}\text{F}$  ( $71.0^{\circ}\text{C}$ ).

### 4-Terminal Strip TB2

Terminal strip TB2 is used for single point power installations only. TB2 distributes L1, L2 and L3 power to TB3. Units with multi-point power connections will not use TB2.

### 5-Terminal Strip TB3

Electric heat line voltage connections are made to terminal strip TB3 located in the upper left corner of the electric heat vestibule. TB3 distributes power to the electric heat components.

### 6-Heating Elements HE1 through HE6

Heating elements are composed of helix wound bare nichrome wire exposed directly to the air stream. Three elements are connected in a three-phase arrangement. The elements in 208/230V units are connected in a "Delta" arrangement. Elements in 460 and 575V units are connected in "Wye" arrangement. Each stage is energized independently by the corresponding contactors located on the electric heat vestibule panel. Once energized, heat transfer is instantaneous. High temperature protection is provided by primary and redundant high temperature limits and overcurrent protection is provided by fuses.

### 7-Fuse F3

Fuse F3 are housed in a fuse block which holds three fuses. Each F3 fuse is connected in series with each leg of electric heat. Figure 16 and table 3 show the fuses used with each electric heat section. For simplicity, the service manual labels the fuses F3 - 1, 2 and F4 - 1, 2.

### 8-Unit Fuse Block F4

Three line voltage fuses F4 provide short circuit and ground fault protection to all cooling components in the KCA/KCB units with electric heat. The fuses are rated in accordance with the amperage of the cooling components.

## ELECTRIC HEAT CONTROL ASSEMBLY

### 1-Electric Heat Relay K9

All KCA/KCB series units with electric heat use an electric heat relay K9. K9 is a N.O. DPDT pilot relay intended to electrically isolate the unit's 24V circuit from the electric heat 24V circuit. K9 is energized by CMC1. K9-1 closes, energizing timer DL2. K9 is located in the electric heat control assembly. See figure 14.

### 2-Time Delay DL2

DL2 is a factory-installed solid state timer used in 22.5 to 60 kW electric heat units. DL2 allows staging by providing a timed-interval between the first and second heating elements. When the timer is energized, the contacts are delayed for 30 seconds before closing. When the timer is de-energized, the contacts are delayed 1 second before opening. DL2 is located in the electric heat control assembly. See figure 14.

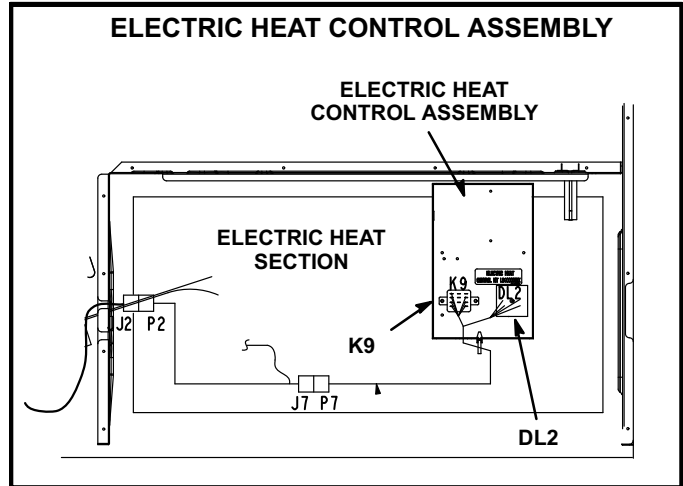


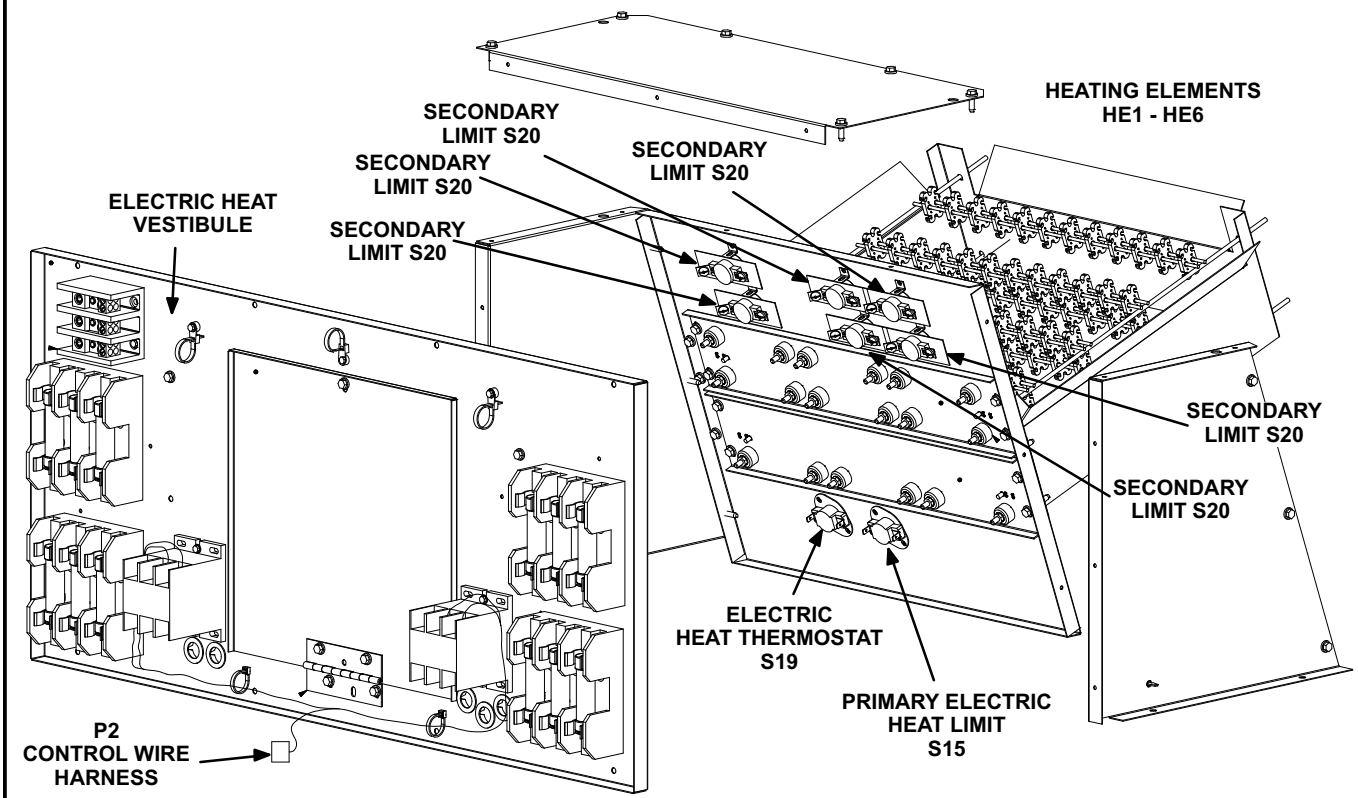
FIGURE 14



**TABLE 3**

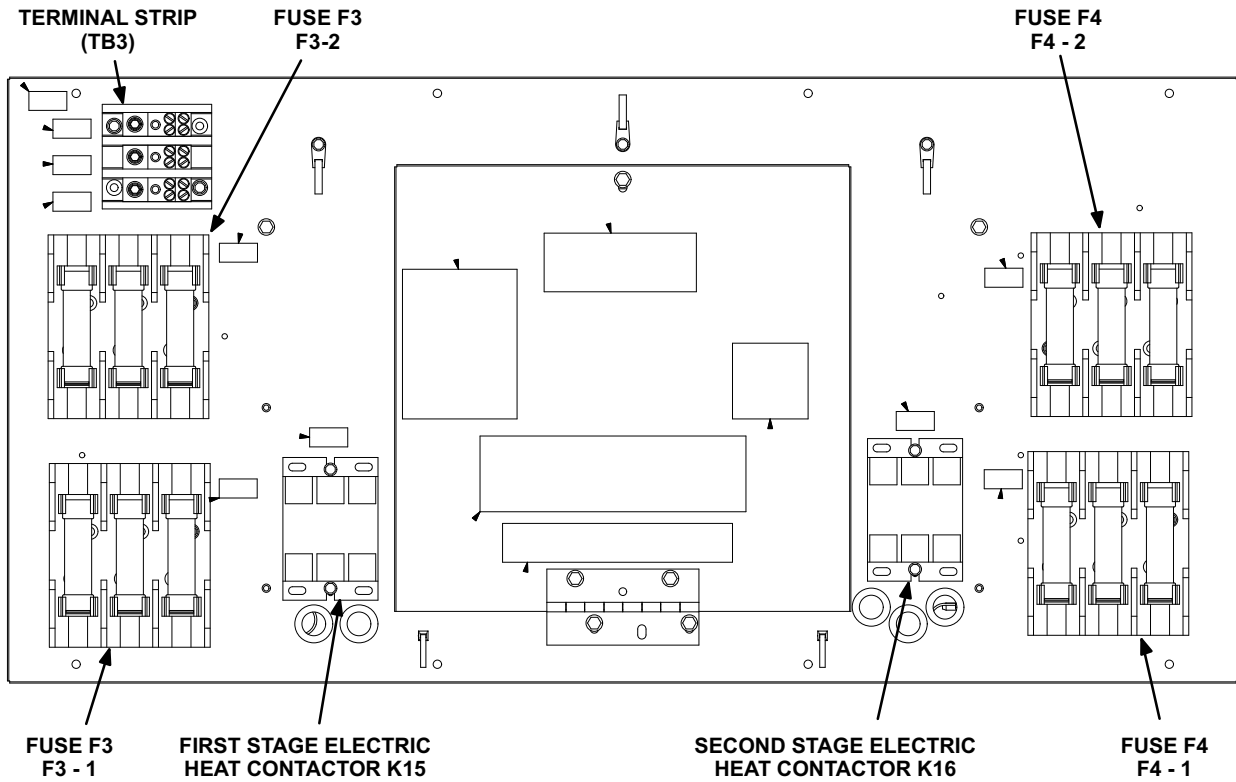
<b>KCA/KCB ELECTRIC HEAT SECTION FUSE RATING</b>					
<b>EHA QUANTITY &amp; SIZE</b>	<b>VOLTAGES</b>	<b>FUSE (3 each)</b>			
		<b>F3 - 1</b>	<b>F3 - 2</b>	<b>F3 - 3</b>	<b>F3 - 4</b>
EHA100-7.5	208/230V	25 Amp 250V	----	----	----
	460V	15 Amp 600V	----	----	----
	575V	10 Amp 600V	----	----	----
EHA100-15	208/230V	50 Amp 250V	----	----	----
	460V	25 Amp 600V	----	----	----
	575V	20 Amp 600V	----	----	----
EHA100-22.5	208/230V	50 Amp 250V	----	----	25 Amp 250V
	460V	25 Amp 600V	----	----	15 Amp 600V
	575V	20 Amp 600V	----	----	10 Amp 600V
EHA100-30	208/230V	50 Amp 250V	----	----	50 Amp 250V
	460V	25 Amp 600V	----	----	25 Amp 600V
	575V	20 Amp 600V	----	----	20 Amp 600V
EHA100-45	208/230V	50 Amp 250V	----	60 Amp 250V	60 Amp 250V
	460V	25 Amp 600V	----	----	50 Amp 600V
	575V	20 Amp 600V	----	----	40 Amp 600V
EHA102-7.5	208/230V	25 Amp 250V	----	----	----
	460V	15 Amp 600V	----	----	----
	575V	10 Amp 600V	----	----	----
EHA150-15	208/230V	50 Amp 250V	----	----	----
	460V	25 Amp 600V	----	----	----
	575V	20 Amp 600V	----	----	----
EHA360-22.5	208/230V	50 Amp 250V	----	----	25 Amp 250V
	460V	25 Amp 600V	----	----	15 Amp 600V
	575V	20 Amp 600V	----	----	10 Amp 600V
EHA150-30	208/230V	50 Amp 250V	----	----	50 Amp 250V
	460V	25 Amp 600V	----	----	25 Amp 600V
	575V	20 Amp 600V	----	----	20 Amp 600V
EHA150-45	208/230V	50 Amp 250V	----	60 Amp 250V	60 Amp 250V
	460V	25 Amp 600V	----	----	50 Amp 600V
	575V	20 Amp 600V	----	----	40 Amp 600V
EHA150-60	208/230V	60 Amp 250V	60 Amp 250V	60 Amp 250V	60 Amp 250V
	460V	50 Amp 600V	----	----	50 Amp 600V
	575V	40 Amp 600V	----	----	40 Amp 600V

**EHA 7.5, 15, 22.5, 30, 45, 60KW  
ELECTRIC HEAT SECTION PARTS ARRANGEMENT**



**FIGURE 15**

**ELECTRIC HEAT VESTIBULE PARTS ARRANGEMENT**



**FIGURE 16**

## II-PLACEMENT AND INSTALLATION

Make sure the unit is installed in accordance with the installation instructions and all applicable codes. See accessories section for conditions requiring use of the optional roof mounting frame.

## III-STARTUP - OPERATION

### A-Preliminary and Seasonal Checks

- 1- Make sure the unit is installed in accordance with the installation instructions and applicable codes.
- 2- Inspect all electrical wiring, both field and factory installed for loose connections. Tighten as required. Refer to unit diagram located on inside of unit compressor access panel.
- 3- Check to ensure that refrigerant lines are in good condition and do not rub against the cabinet or other refrigerant lines.
- 4- Check voltage at the disconnect switch. Voltage must be within the range listed on the nameplate. If not, consult the power company and have the voltage corrected before starting the unit.
- 5- Recheck voltage and amp draw with unit running. If voltage is not within range listed on unit nameplate, stop unit and consult power company. Refer to unit nameplate for maximum rated load amps.

### B-Cooling Startup

*Supply Air Inverter Units - Refer to the Inverter Start-Up section.*

- 1- Initiate first and second stage cooling demands according to instructions provided with thermostat.

- 2- *No Economizer Installed in Unit -*

#### 092, 102, 120 Units

A first-stage cooling demand (Y1) will energize compressor 1 and both condenser fans. An increased cooling demand (Y2) will energize compressor 2.

#### 150 Units

A first-stage cooling demand (Y1) will energize compressor 1 and condenser fan 1. An increased cooling demand (Y2) will energize compressor 2 and condenser fan 2.

#### *Units Equipped With Economizer -*

When outdoor air is acceptable, a first-stage cooling demand (Y1) will energize the economizer. An increased cooling demand (Y2) will energize compressor 1 and both condenser fans. When outdoor air is not acceptable unit will operate as though no economizer is installed.

- 3- Units contain two refrigerant circuits or stages. See figure 17 or 18.

- 4- Each refrigerant circuit is separately charged with R-410A refrigerant. See unit rating plate for correct amount of charge.

*NOTE - Refer to IV-CHARGING for proper method to check refrigerant charge.*

### Three Phase Scroll Compressor Voltage Phasing

Three phase power supplied to the unit disconnect switch must be phased sequentially to ensure the scroll compressor and indoor blower rotate in the correct direction. Compressor and blower are wired in phase at the factory. Power wires are color-coded as follows: line 1-red, line 2-yellow, line 3-blue.

- 1- Observe suction and discharge pressures and blower rotation on unit start-up.
- 2- Suction pressure must drop, discharge pressure must rise and blower rotation must match rotation marking.

If pressure differential is not observed or blower rotation is not correct:

- 3- Disconnect all remote electrical power supplies.
- 4- Reverse any two field-installed wires connected to the line side of K2 contactor or disconnect switch if installed. Do not reverse wires at blower contactor.
- 5- Make sure the connections are tight.

Discharge and suction pressures should operate at their normal start-up ranges.

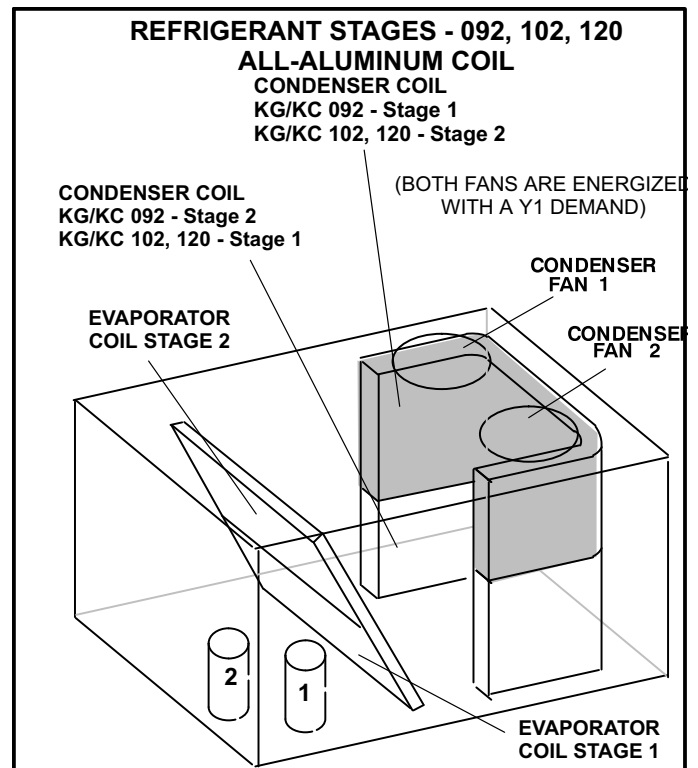
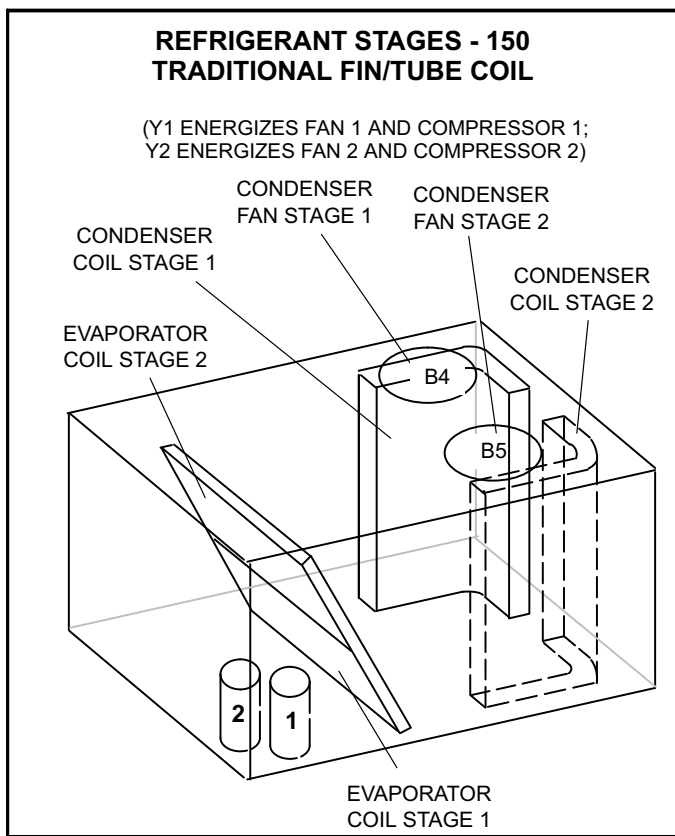


FIGURE 17



### C-Safety or Emergency Shutdown

Turn off power to unit.

### IV-CHARGING

#### A-Refrigerant Charge and Check - All-Aluminum Coil

KC 092, 102, 120

## ⚠ WARNING

Refrigerant can be harmful if it is inhaled. Refrigerant must be used and recovered responsibly.

Failure to follow this warning may result in personal injury or death.

**WARNING-Do not exceed nameplate charge under any condition.**

This unit is factory charged and should require no further adjustment. If the system requires additional refrigerant, re-claim the charge, evacuate the system, and add required nameplate charge.

**NOTE** - System charging is not recommended below 60°F (15°C). In temperatures below 60°F (15°C), the charge **must** be weighed into the system.

If weighing facilities are not available, or to check the charge, use the following procedure:

#### **IMPORTANT - Charge unit in standard cooling mode.**

- 1- Make sure outdoor coil is clean. Attach gauge manifolds and operate unit at full CFM in cooling mode with economizer disabled until system stabilizes (approximately five minutes). Make sure all outdoor air dampers are closed.
- 2- Check each system separately with all stages operating. Compare the normal operating pressures (see tables 4 - 10) to the pressures obtained from the gauges. Check unit components if there are significant differences.
- 3- Measure the outdoor ambient temperature and the suction pressure. Refer to the appropriate circuit charging curve to determine a target liquid temperature.

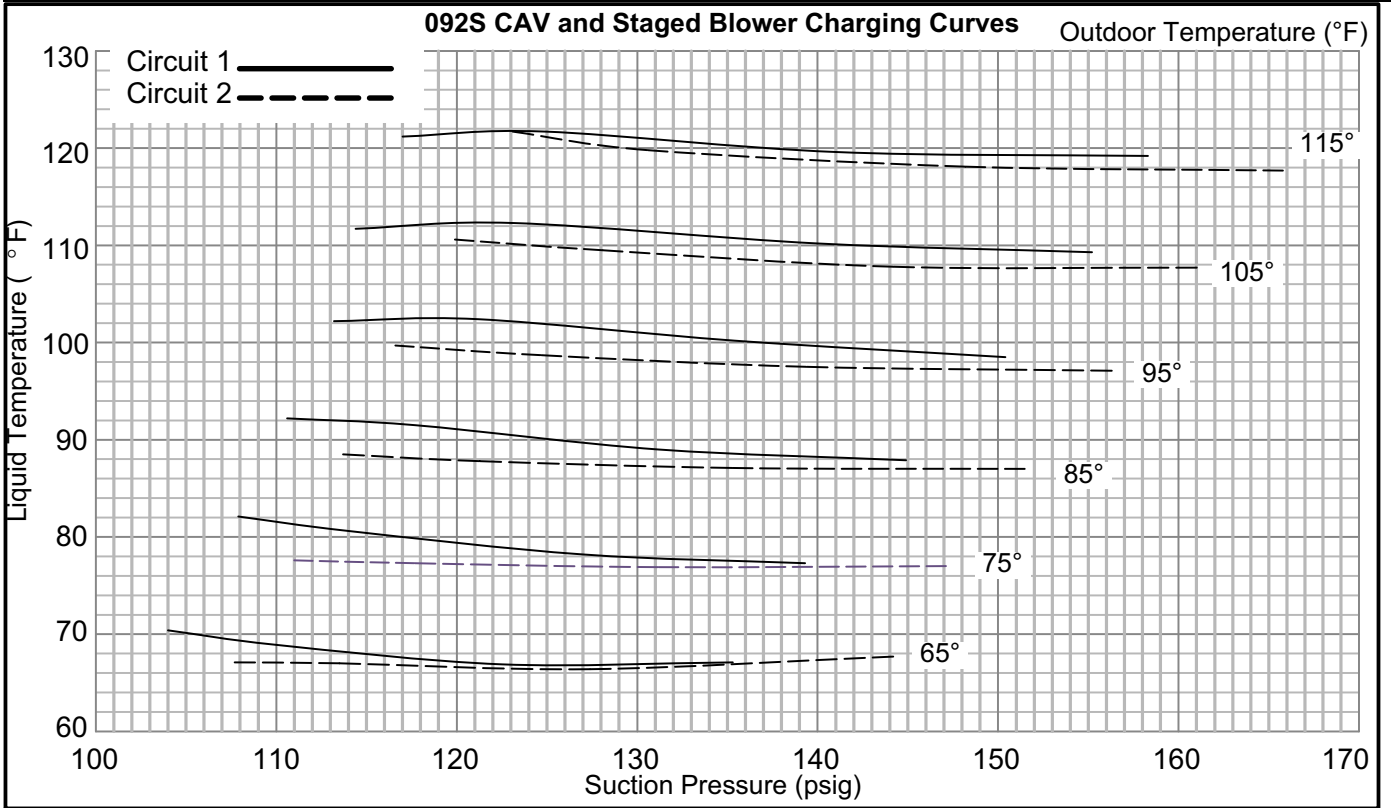
*Note - Pressures are listed for sea level applications.*

- 4- Use the same thermometer to accurately measure the liquid temperature (in the outdoor section).
  - If measured liquid temperature is higher than the target liquid temperature, add refrigerant to the system.
  - If measured liquid temperature is lower than the target liquid temperature, recover some refrigerant from the system.
- 5- Add or remove charge in increments. Allow the system to stabilize each time refrigerant is added or removed.
- 6- Continue the process until measured liquid temperature agrees with the target liquid temperature. Do not go below the target liquid temperature when adjusting charge. Note that suction pressure can change as charge is adjusted.
- 7- Example KC 092S Circuit 1: At 95°F outdoor ambient and a measured suction pressure of 130psig, the target liquid temperature is 101°F. For a measured liquid temperature of 112°F, add charge in increments until measured liquid temperature agrees with the target liquid temperature.

**TABLE 4**

**KCB092S CAV and Staged Blower Normal Operating Pressures**

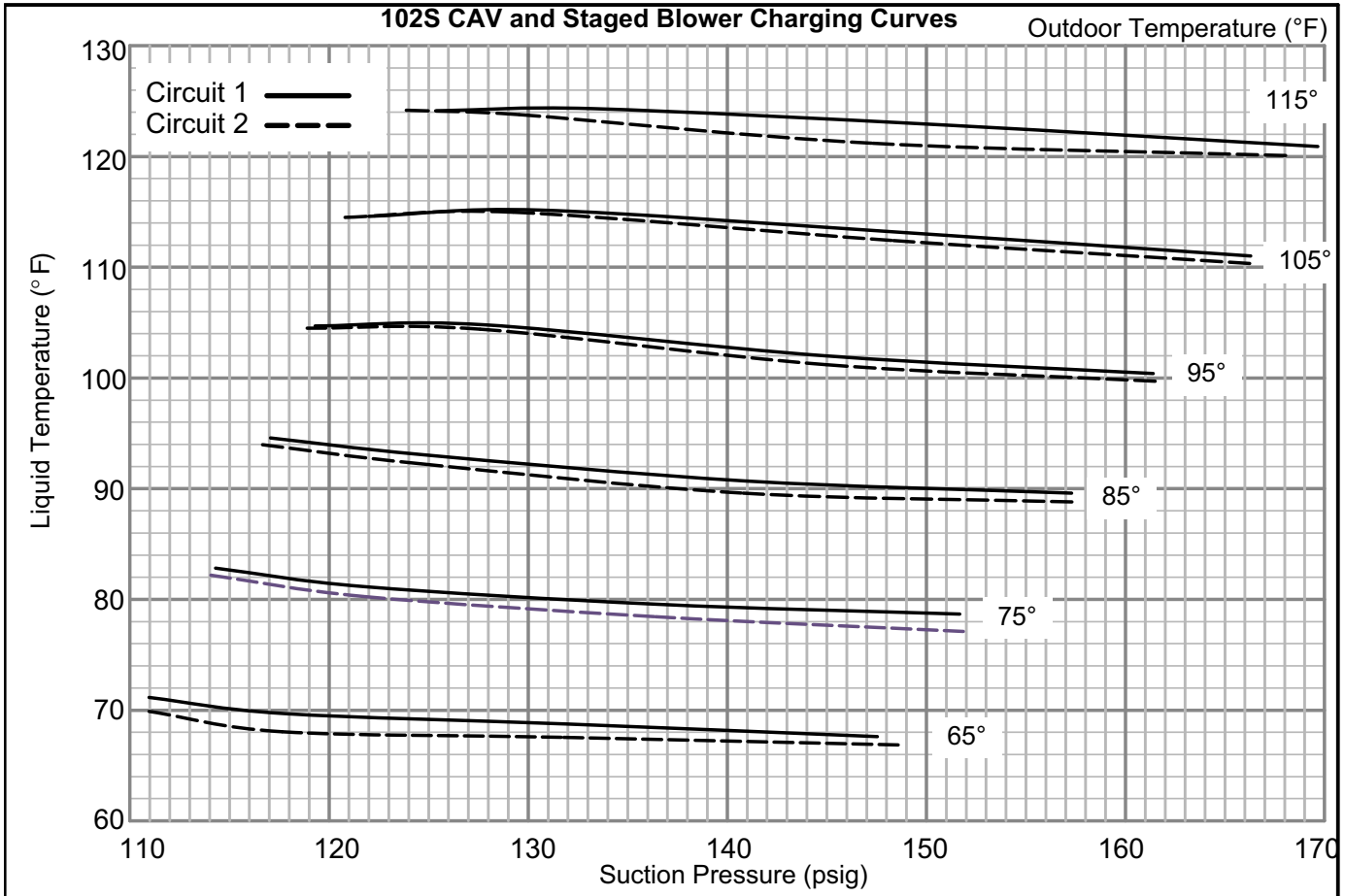
	Outdoor Coil Entering Air Temperature											
	65 °F		75 °F		85 °F		95 °F		105 °F		115 °F	
	Suct (psig)	Disc (psig)	Suct (psig)	Disc (psig)	Suct (psig)	Disc (psig)	Suct (psig)	Disc (psig)	Suct (psig)	Disc (psig)	Suct (psig)	Disc (psig)
Circuit 1	104	244	108	282	111	324	113	370	114	420	117	474
	110	248	114	286	118	328	121	375	123	425	125	479
	123	258	127	296	131	339	135	385	140	436	141	491
	135	280	139	310	145	352	150	400	155	452	158	507
Circuit 2	108	244	111	282	114	323	117	367	120	417	123	470
	114	250	118	287	121	328	125	373	128	422	131	476
	127	264	131	301	135	341	139	386	144	437	148	489
	144	290	147	321	152	363	156	410	161	460	166	514



**TABLE 5**

**KCB102S CAV and Staged Blower Normal Operating Pressures**

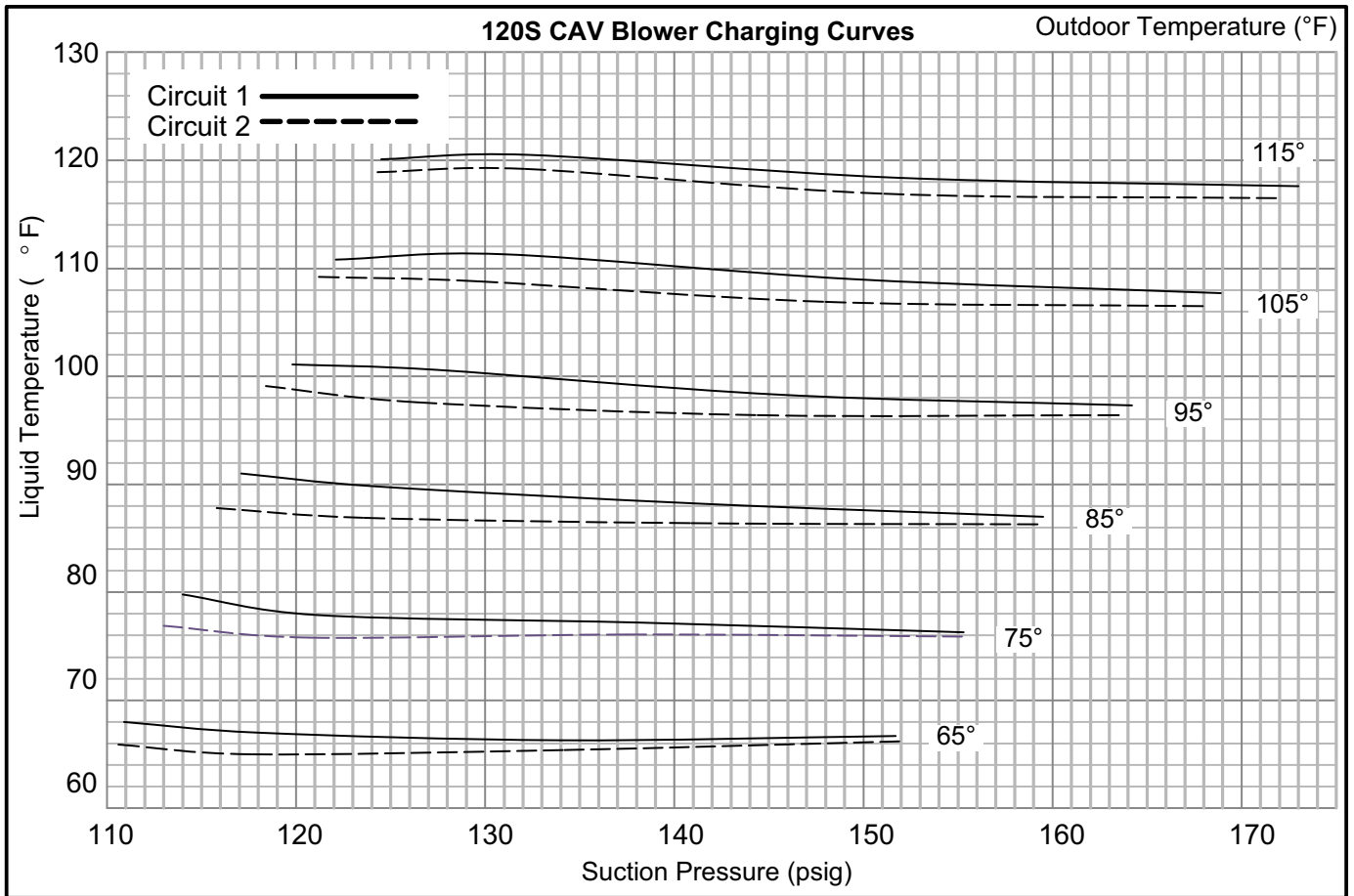
	Outdoor Coil Entering Air Temperature											
	65 °F		75 °F		85 °F		95 °F		105 °F		115 °F	
	Suct (psig)	Disc (psig)	Suct (psig)	Disc (psig)	Suct (psig)	Disc (psig)	Suct (psig)	Disc (psig)	Suct (psig)	Disc (psig)	Suct (psig)	Disc (psig)
Circuit 1	111	252	114	289	117	332	119	378	122	428	125	483
	118	256	122	295	125	337	128	383	131	434	133	489
	132	269	136	307	141	350	145	396	149	447	151	502
	148	285	152	322	157	367	161	413	166	465	170	518
Circuit 2	111	249	114	288	117	331	119	377	121	428	124	482
	118	254	122	295	125	336	128	383	129	433	130	483
	132	271	136	308	141	350	145	397	148	447	147	500
	149	291	152	325	157	371	162	417	166	468	168	520



**TABLE 6**

**KCB120S CAV Blower Normal Operating Pressures**

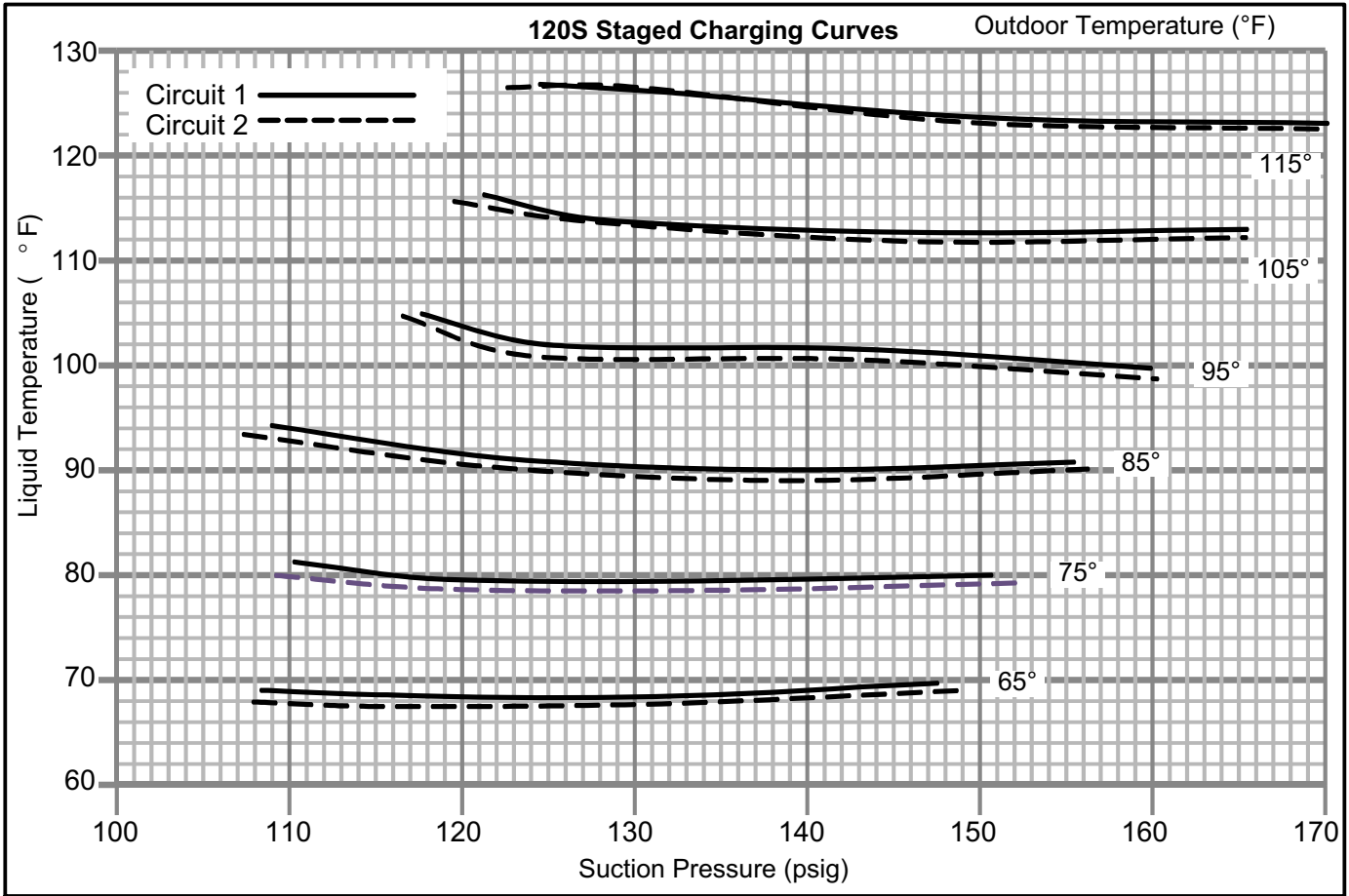
	Outdoor Coil Entering Air Temperature											
	65 °F		75 °F		85 °F		95 °F		105 °F		115 °F	
	Suct (psig)	Disc (psig)	Suct (psig)	Disc (psig)	Suct (psig)	Disc (psig)	Suct (psig)	Disc (psig)	Suct (psig)	Disc (psig)	Suct (psig)	Disc (psig)
Circuit 1	111	261	114	301	117	343	120	389	122	437	125	489
	118	266	121	304	124	349	127	393	131	444	132	496
	134	286	138	324	142	366	146	411	149	463	152	518
	152	315	155	348	160	390	164	438	169	492	173	547
Circuit 2	111	255	113	293	116	333	118	378	121	427	124	481
	118	264	121	299	124	341	126	385	130	434	132	488
	134	288	138	324	141	364	144	407	148	458	151	513
	152	319	155	352	159	393	164	437	168	488	172	545



**TABLE 7**

**KCA120S Staged Blower Normal Operating Pressures**

	Outdoor Coil Entering Air Temperature											
	65 °F		75 °F		85 °F		95 °F		105 °F		115 °F	
	Suct (psig)	Disc (psig)	Suct (psig)	Disc (psig)	Suct (psig)	Disc (psig)	Suct (psig)	Disc (psig)	Suct (psig)	Disc (psig)	Suct (psig)	Disc (psig)
Circuit 1	108	263	110	303	109	345	118	399	121	452	124	509
	115	269	119	308	123	352	125	398	128	454	132	516
	130	290	135	328	139	369	143	420	147	474	150	537
	148	319	151	354	155	398	160	440	166	508	170	567
Circuit 2	108	258	109	298	107	340	117	394	120	447	123	506
	116	265	119	305	122	350	124	394	127	450	130	512
	132	289	135	326	139	366	143	417	146	473	149	539
	149	319	152	354	156	397	160	437	165	505	170	566

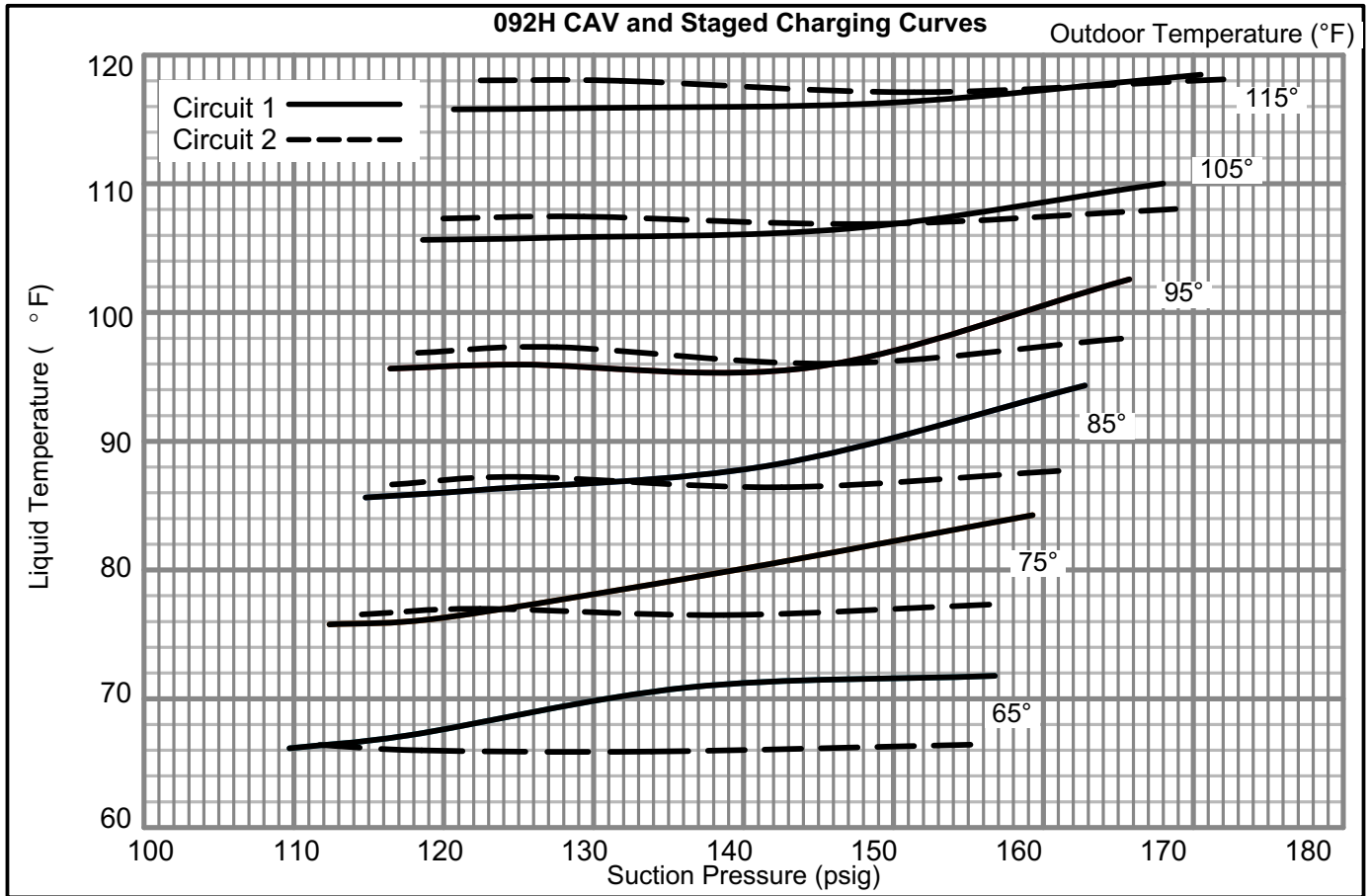




**TABLE 8**

**KCA092H CAV and Staged Normal Operating Pressures**

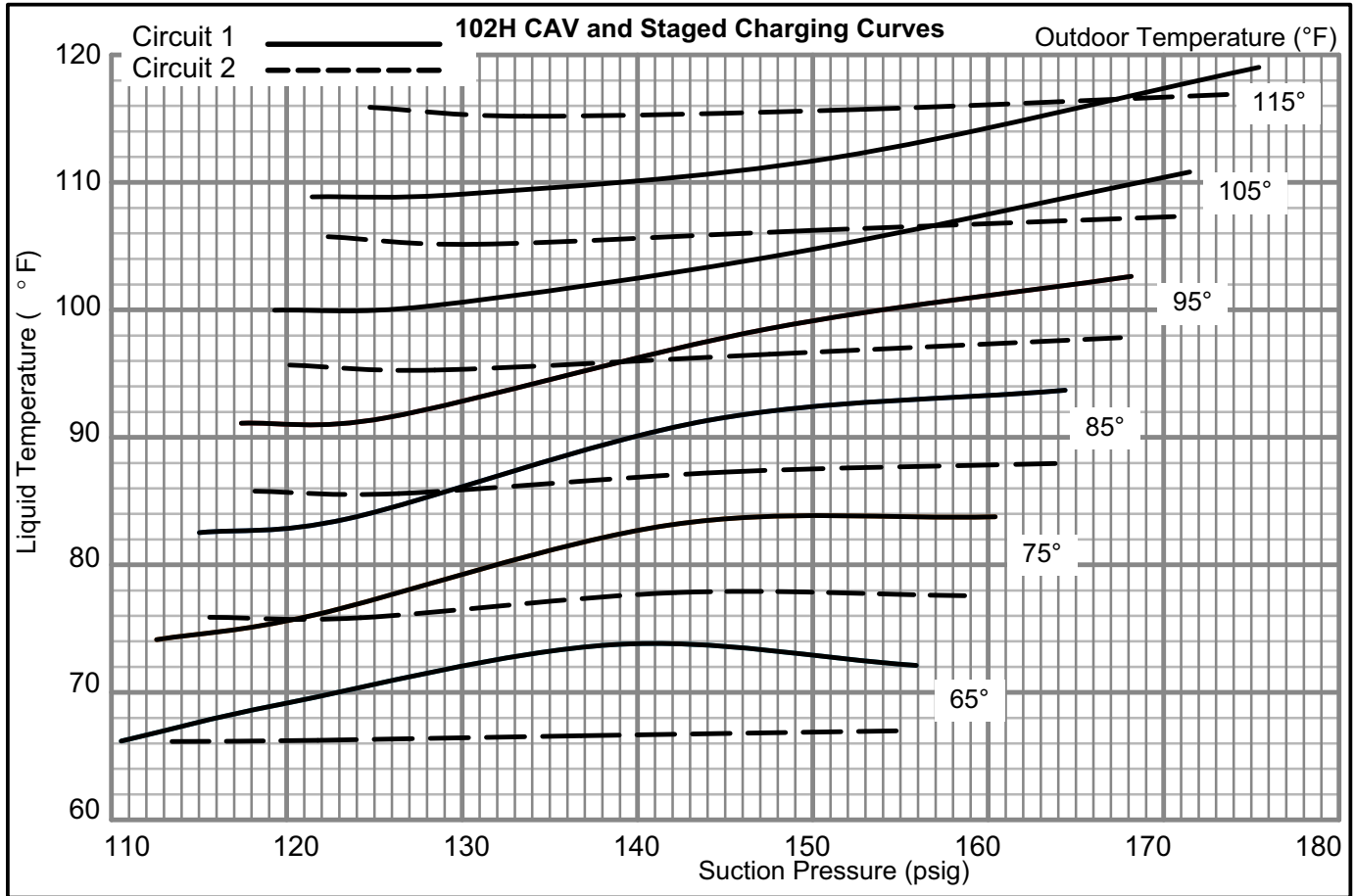
	Outdoor Coil Entering Air Temperature											
	65 °F		75 °F		85 °F		95 °F		105 °F		115 °F	
	Suct (psig)	Disc (psig)	Suct (psig)	Disc (psig)	Suct (psig)	Disc (psig)	Suct (psig)	Disc (psig)	Suct (psig)	Disc (psig)	Suct (psig)	Disc (psig)
Circuit 1	110	234	112	273	115	317	116	367	119	428	121	503
	118	236	120	275	123	319	125	369	127	426	130	497
	136	240	139	278	142	320	145	369	147	422	150	483
	157	248	159	284	163	325	166	373	168	424	171	482
Circuit 2	112	232	115	269	117	313	118	371	120	441	122	523
	119	237	122	273	125	316	128	367	129	431	132	508
	134	243	139	279	143	320	146	370	149	424	151	488
	155	253	156	287	161	328	165	376	169	427	172	487



**TABLE 9**

**KCA102H CAV and Staged Normal Operating Pressures**

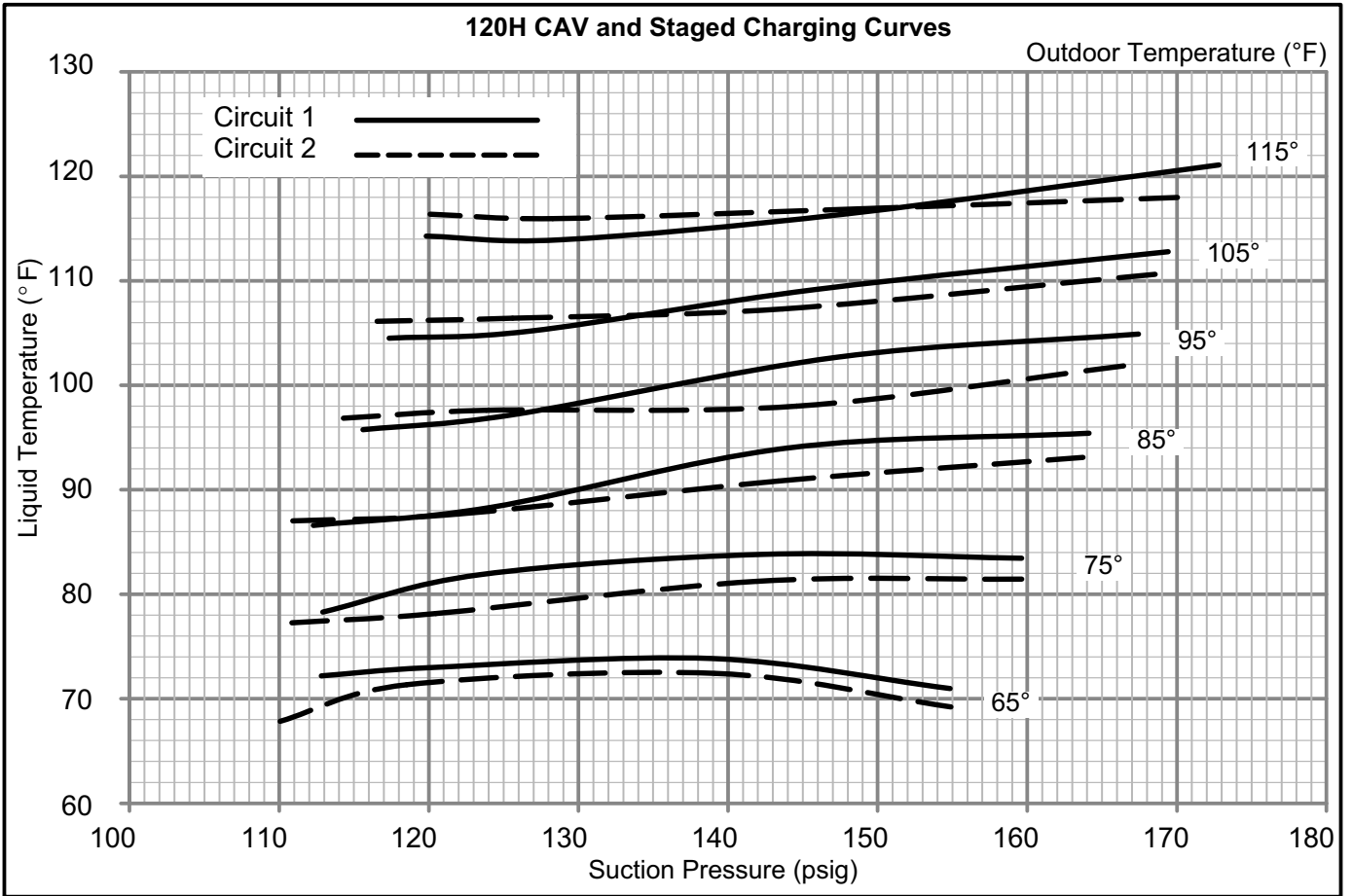
		Outdoor Coil Entering Air Temperature											
		65 °F		75 °F		85 °F		95 °F		105 °F		115 °F	
		Suct (psig)	Disc (psig)	Suct (psig)	Disc (psig)	Suct (psig)	Disc (psig)	Suct (psig)	Disc (psig)	Suct (psig)	Disc (psig)	Suct (psig)	Disc (psig)
Circuit 1		111	234	113	273	115	316	117	365	119	419	121	480
		120	236	121	275	124	317	126	365	128	417	130	476
		139	241	142	279	144	321	147	367	148	420	151	476
		156	251	160	287	164	328	168	374	171	424	175	480
Circuit 2		113	233	116	273	118	317	120	371	122	439	125	530
		122	233	124	273	126	317	128	369	131	428	134	502
		137	242	142	278	145	320	148	369	150	426	153	489
		155	251	159	288	164	328	168	375	171	429	174	488



**TABLE 10**

**KCA120H CAV and Staged Normal Operating Pressures**

	Outdoor Coil Entering Air Temperature											
	65 °F		75 °F		85 °F		95 °F		105 °F		115 °F	
	Suct (psig)	Disc (psig)	Suct (psig)	Disc (psig)	Suct (psig)	Disc (psig)	Suct (psig)	Disc (psig)	Suct (psig)	Disc (psig)	Suct (psig)	Disc (psig)
Circuit 1	113	251	113	290	112	331	116	383	117	439	120	520
	120	254	123	293	124	338	126	388	127	441	129	510
	139	264	142	303	144	345	147	393	146	445	148	510
	155	278	160	314	164	357	167	403	169	456	173	512
Circuit 2	110	251	111	287	111	329	114	388	117	454	120	538
	119	249	120	291	122	336	124	389	126	447	128	520
	139	259	142	297	143	337	145	390	144	444	149	514
	155	274	160	307	164	349	166	393	169	448	170	510



### Charge Verification - Approach Method - AHRI Testing

- Using the same thermometer, compare liquid temperature (at condenser outlet) to outdoor ambient temperature.

Approach Temperature = Liquid temperature minus ambient temperature.

- Approach temperature should match values shown in table 11. An approach temperature greater than this value indicates an undercharge. An approach temperature less than this value indicates an overcharge.
- The approach method is not valid for grossly overcharged or undercharged systems. Use tables 4 through 10 as a guide for typical operating pressures.

**TABLE 11  
APPROACH TEMPERATURE**

KCA Unit	Liquid Temp. Minus Ambient Temp.	
	1st Stage	2nd Stage
092	9°F ± 1 (5.0°C ± 0.5)	8°F ± 1 (4.4°C ± 0.5)
102	7°F ± 1 (3.9°C ± 0.5)	6°F ± 1 (3.3°C ± 0.5)
120	8°F ± 1 (4.4°C ± 0.5)	6°F ± 1 (3.3°C ± 0.5)

### B-Refrigerant Charge and Check - Fin/Tube Coil & TXV

#### KC 150S

**WARNING-Do not exceed nameplate charge under any condition.**

This unit is factory charged and should require no further adjustment. If the system requires additional refrigerant, reclaim the charge, evacuate the system, and add required nameplate charge.

*NOTE - System charging is not recommended below 60°F (15°C). In temperatures below 60°F (15°C), the charge **must** be weighed into the system.*

If weighing facilities are not available, or to check the charge, use the following procedure:

#### IMPORTANT - Charge unit in standard cooling mode.

- Attach gauge manifolds and operate unit in cooling mode with economizer disabled until system stabilizes (approximately five minutes). Make sure outdoor air dampers are closed.
- Check each system separately with all stages operating.
- Use a thermometer to accurately measure the outdoor ambient temperature.
- Apply the outdoor temperature to table 12 to determine normal operating pressures. Pressures are

listed for sea level applications at 80°F dry bulb and 67°F wet bulb return air.

- Compare the normal operating pressures to the pressures obtained from the gauges. Minor variations in these pressures may be expected due to differences in installations. Significant differences could mean that the system is not properly charged or that a problem exists with some component in the system. **Correct any system problems before proceeding.**
- If discharge pressure is high, remove refrigerant from the system. If discharge pressure is low, add refrigerant to the system.
  - Add or remove charge in increments.
  - Allow the system to stabilize each time refrigerant is added or removed.
- Use the following approach method along with the normal operating pressures to confirm readings.

**TABLE 12  
KCB150S Fin/Tube - TXV**

Outdoor Coil Entering Air Temp	CIRCUIT 1		CIRCUIT 2	
	Dis-charge ±10 psig	Suction ±5 psig	Dis-charge ±10 psig	Suction ±5 psig
65°F	276	131	275	125
75°F	317	133	314	128
85°F	357	136	363	131
95°F	399	139	408	136
105°F	450	142	457	140
115°F	502	145	509	142

### Charge Verification - Approach Method - AHRI Testing (Fin/Tube Coil Continued)

- Using the same thermometer, compare liquid temperature to outdoor ambient temperature.
 

Approach Temperature = Liquid temperature (at condenser outlet) minus ambient temperature.
- Approach temperature should match values in table 13. An approach temperature greater than value shown indicates an undercharge. An approach temperature less than value shown indicates an overcharge.
- The approach method is not valid for grossly over or undercharged systems. Use table 12 as a guide for typical operating pressures.

**TABLE 13  
APPROACH TEMPERATURE - Fin/Tube - TXV**

Unit	Liquid Temp. Minus Ambient Temp.	
	1st Stage	2nd Stage
150S	4°F ± 1 (2.2°C ± 0.5)	6°F ± 1 (3.3°C ± 0.5)

## V- SYSTEMS SERVICE CHECKS

### A-Cooling System Service Checks

KCA/KCB units are factory charged and require no further adjustment; however, charge should be checked periodically using the approach method. The approach method compares actual liquid temperature with the outdoor ambient temperature. See section IV- CHARGING.

*NOTE - When unit is properly charged discharge line pressures should approximate those in tables 4 through 10 and table 12.*

### ⚠ IMPORTANT

The Clean Air Act of 1990 bans the intentional venting of refrigerant (CFC's and HCFC's) as of July 1, 1992. Approved methods of recovery, recycling or reclaiming must be followed. Fines and/or incarceration may be levied for non-compliance.

## VI-MAINTENANCE

The unit should be inspected once a year by a qualified service technician.

### ⚠ WARNING



Electric shock hazard. Can cause injury or death. Before attempting to perform any service or maintenance, turn the electrical power to unit OFF at disconnect switch(es). Unit may have multiple power supplies.

### ⚠ CAUTION

Label all wires prior to disconnection when servicing controls. Wiring errors can cause improper and dangerous operation. Verify proper operation after servicing.

### A-Filters

Units are equipped with four 20 X 25 X 2" filters. Filters should be checked and replaced when necessary with filters of like kind and size. Take note of air flow direction marking on filter frame when reinstalling filters. See figure 19. *Filters must be U.L.C. certified or equivalent for use in Canada.*

### B-Lubrication

All motors are lubricated at the factory. No further lubrication is required.

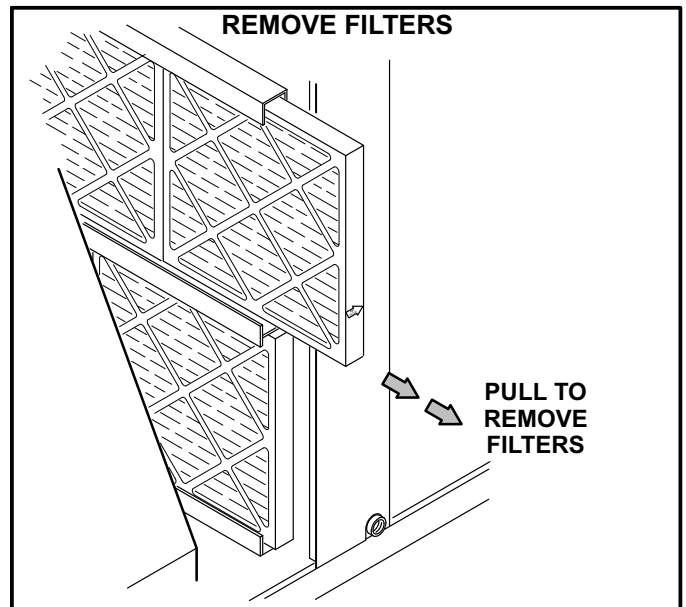


FIGURE 19

### C-Evaporator Coil

Inspect and clean coil at beginning of each cooling season. Clean using mild detergent or commercial coil cleanser. Flush coil and condensate drain with water taking care not to get insulation, filters and return air ducts wet.

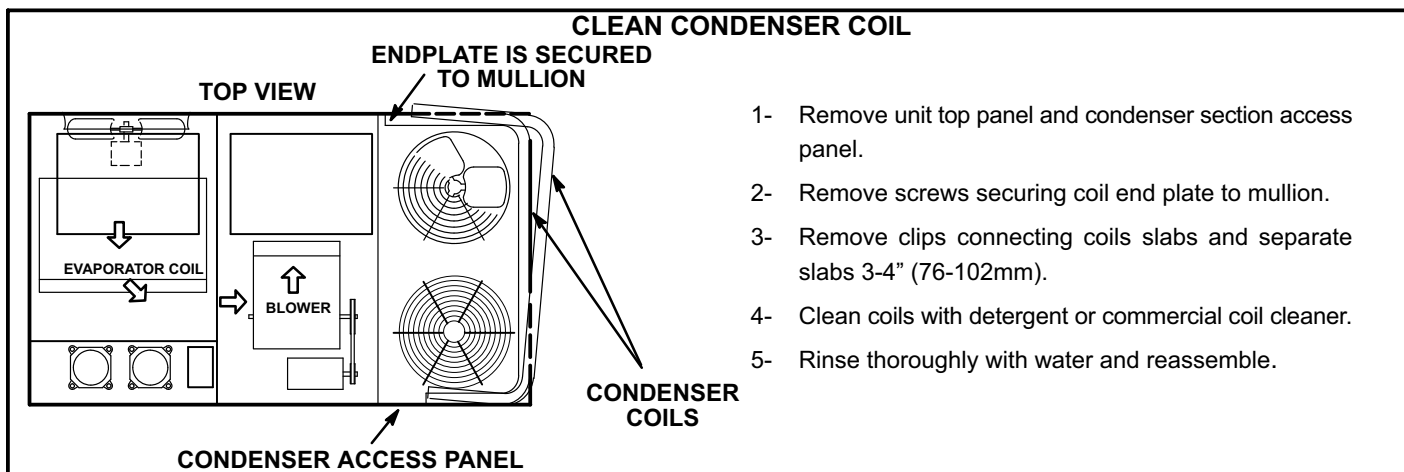
### D-Condenser Coil

Clean condenser coil annually with detergent or commercial coil cleaner and inspect monthly during the cooling season. Condenser coils are made of one, two and three formed slabs. Dirt and debris may become trapped between the slabs. To clean between slabs, carefully separate coil slabs and wash them thoroughly. See figure 20. Flush coils with water following cleaning.

*NOTE - Remove all screws and gaskets prior to cleaning procedure and replace upon completion.*

### E-Supply Blower Wheel

Annually inspect supply air blower wheel for accumulated dirt or dust. Turn off power before attempting to remove access panel or to clean blower wheel.



**FIGURE 20**

## VII-ACCESSORIES

The accessories section describes the application of most of the optional accessories which can be factory or field installed to the KCA/KCB units. OPTIONAL ACCESSORIES section (see table of contents) show specific size per unit.

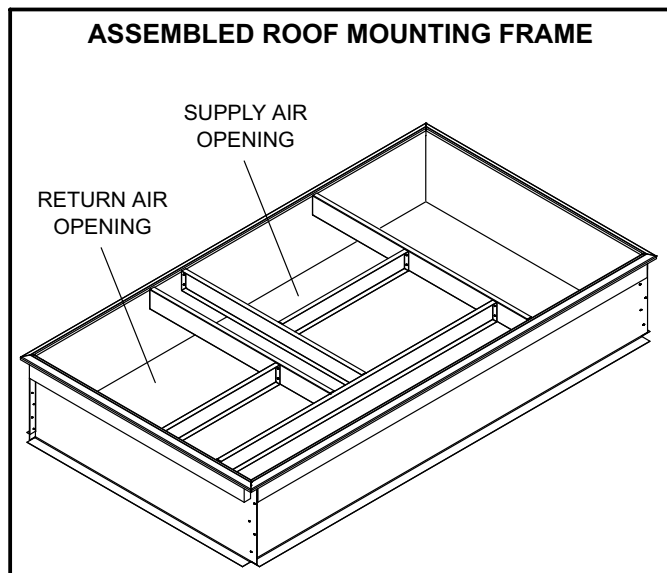
### A-C1CURB Mounting Frames

When installing units on a combustible surface for downflow discharge applications, a C1CURB roof mounting frame is used. The roof mounting frames are recommended in all other applications but not required. If the KCA/KCB units are not mounted on a flat (roof) surface, they **MUST** be supported under all edges and under the middle of the unit to prevent sagging. The units **MUST** be mounted level within 1/16" per linear foot or 5mm per meter in any direction.

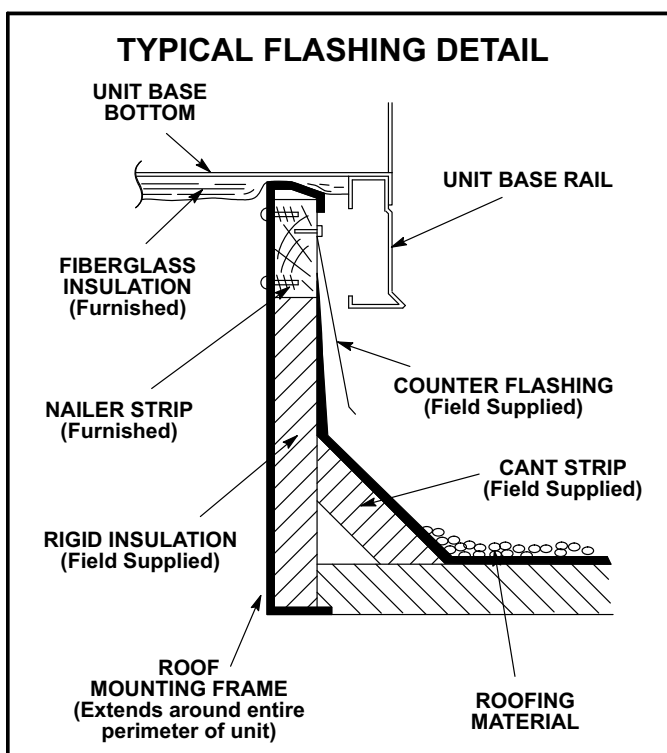
The assembled C1CURB mounting frame is shown in figure 21. Refer to the roof mounting frame installation instructions for details of proper assembly and mounting. The roof mounting frame **MUST** be squared to the roof and level before mounting. Plenum system **MUST** be installed before the unit is set on the mounting frame. Typical roof curbing and flashing is shown in figure 22. Refer to the roof mounting frame installation instructions for proper plenum construction and attachment.

### B-Transitions

Optional supply/return transition C1DIFF30B-1, C1DIFF31B-1 and C1DIFF32B-1 are available for use with the KCA/KCB 7.5 through 12.5 ton units, utilizing optional C1CURB roof mounting frames. Transition must be installed in the C1CURB mounting frame before setting the unit on the frame. Refer to the manufacturer's instructions included with the transition for detailed installation procedures.

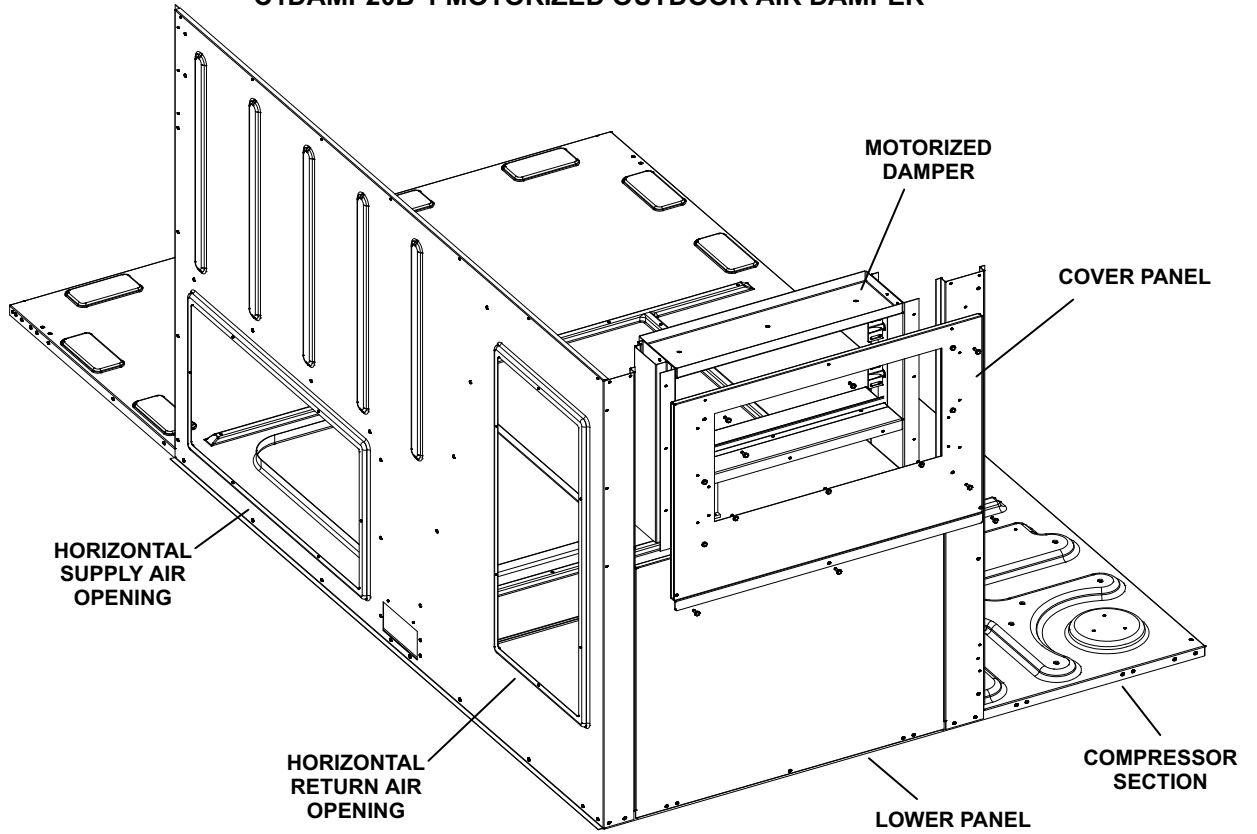


**FIGURE 21**

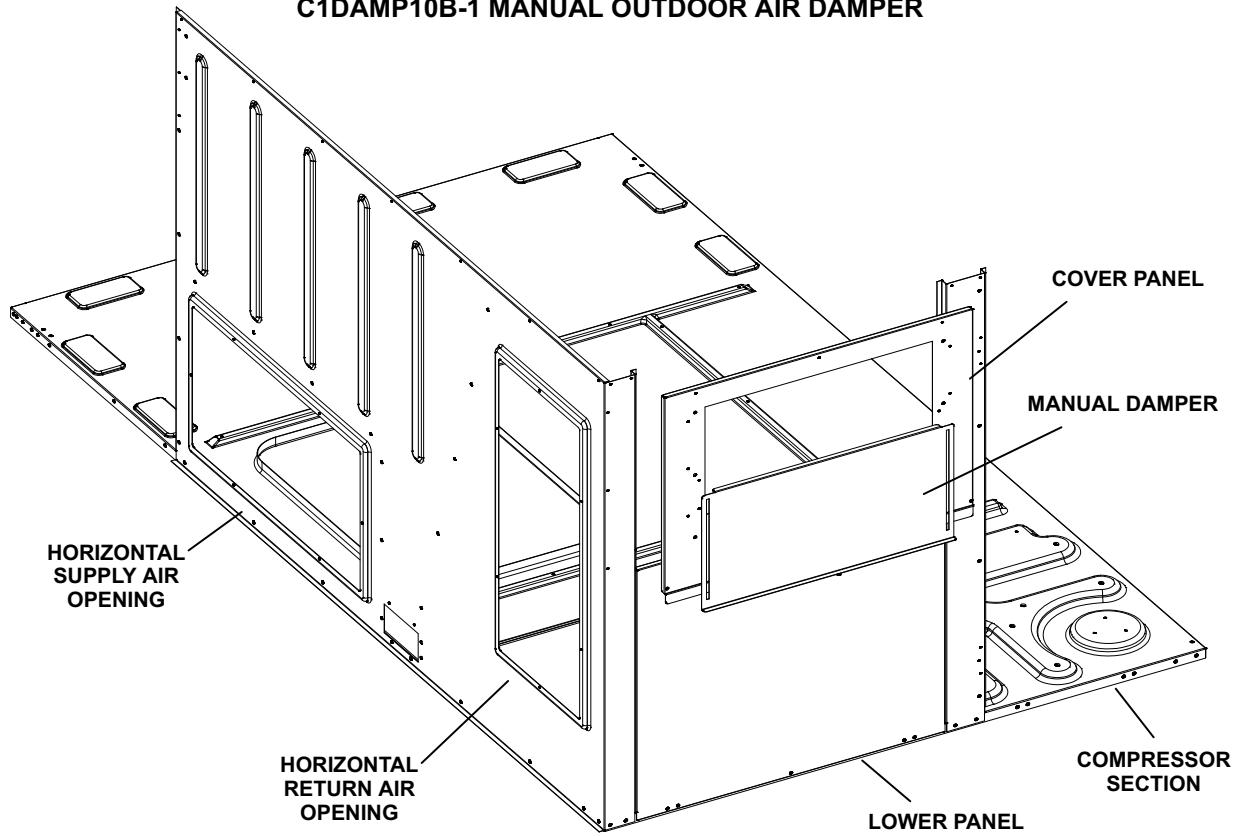


**FIGURE 22**

**C1DAMP20B-1 MOTORIZED OUTDOOR AIR DAMPER**



**C1DAMP10B-1 MANUAL OUTDOOR AIR DAMPER**



**FIGURE 23**

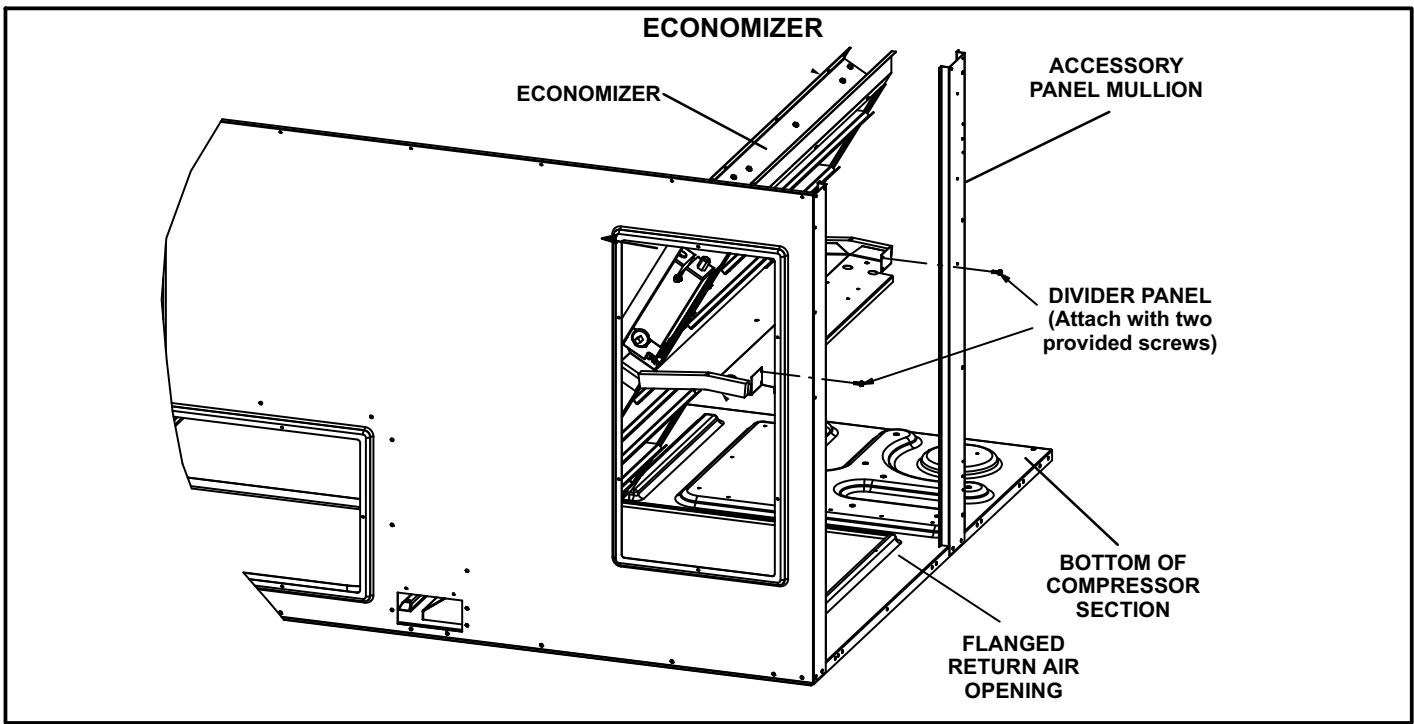


FIGURE 24

**C-C1DAMP Outdoor Air Dampers**  
**Field- or Factory-Installed**

Optional manual (C1DAMP10B-1) and motorized (C1DAMP20B-1) outdoor air dampers provide up to 25 percent fresh air for return. Motorized damper opens to minimum position simultaneously with the blower during the occupied period and remains closed during the unoccupied period. Manual damper assembly is manually operated; damper position is manually set at installation and remains in that position. See figure 23.

**D-Supply and Return Diffusers**

Optional flush-mount diffuser/return FD11 and extended-mount diffuser/return RTD11 are available for use with all KCA/KCB units. Refer to manufacturer's instructions included with transition for detailed installation procedures.

**E-K1ECON20B / K1ECON22B-1 Economizer**  
**(Field- or Factory-Installed)**

See specific economizer installation instructions for more detail for both K1ECON20B and high performance economizer K1ECON22B1 (Title 24 California). Economizers use outdoor air for free cooling when temperature and/or humidity is suitable. See figure 24. Below is a brief description of the K1ECON20B economizer.

The mixed air temperature sensor (R1) measures the supply air sensible temperature. See figure 25. The outdoor air sensible control is the default economizer control. An outdoor air single sensible sensor, S175, is also provided. See table 14 for outdoor and return air (OA and RA) sensor options. Refer to instructions provided with sensors for installation.

An IAQ sensor is used when demand control ventilation (DCV) is specified. Damper minimum position can be set lower than traditional minimum air requirements resulting in cost savings. The IAQ sensor allows the A6 to open dampers to traditional ventilation requirements as room occupancy (CO<sub>2</sub>) increases.

TABLE 14

Sensors	Dampers will modulate to 55°F discharge air (RT6) when:
Single OA Sensible	OA temperature (S175) is lower than free cooling setpoint.
Single OA Sensible	OA temperature and humidity (A7) is lower than free cooling setpoint.
Differential Enthalpy - 1 in OA and 1 in RA	OA temperature and humidity (A7) is lower than RA temperature and humidity (A62).
IAQ Sensor	CO <sub>2</sub> sensed (A63) is higher than CO <sub>2</sub> setpoint.



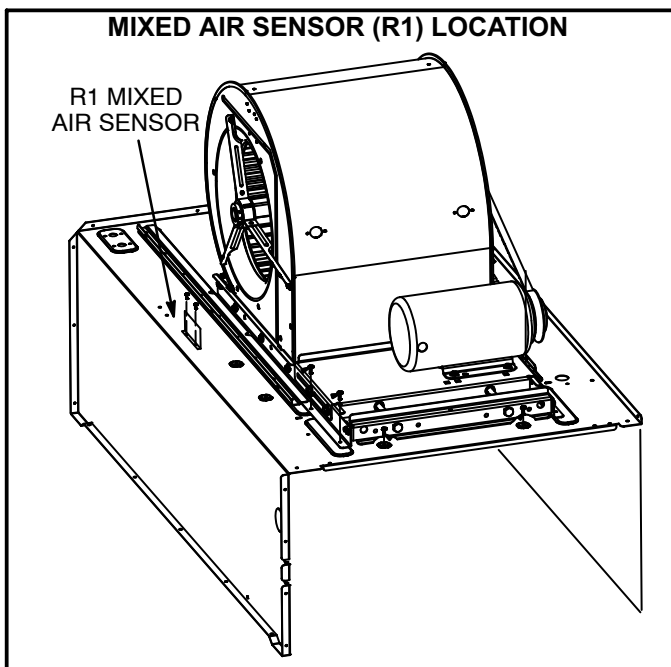


FIGURE 25

**A6 Enthalpy Control LED'S**

A steady green Free Cool LED indicates that outdoor air is suitable for free cooling.

When an optional IAQ sensor is installed, a steady green DCV LED indicates that the IAQ reading is higher than the setpoint, requiring more fresh air. See figure 26.

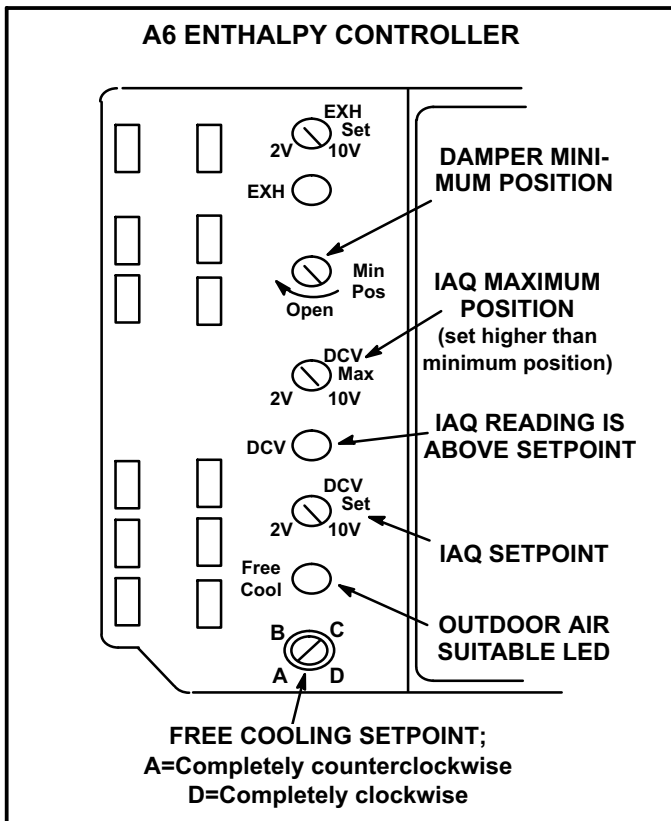


FIGURE 26

**Free Cooling Setpoint**

Outdoor air is considered suitable when temperature and humidity are less than the free cooling setpoints shown in table 15. Setting A is recommended. See figure 26. At setting A, free cooling will be energized when outdoor air is approximately 73°F (23°C) and 50% relative humidity. If indoor air is too warm or humid, lower the setpoint to B. At setting B, free cooling will be energized at 70°F (21°C) and 50% relative humidity.

When an optional A62 differential sensor is installed, turn A6 enthalpy control free cooling setpoint potentiometer completely clockwise to position "D".

**TABLE 15  
ENTHALPY CONTROL SETPOINTS**

Control Setting	Free Cooling Setpoint At 50% RH
A	73° F (23° C)
B	70° F (21° C)
C	67° F (19° C)
D	63° F (17° C)

**Damper Minimum Position**

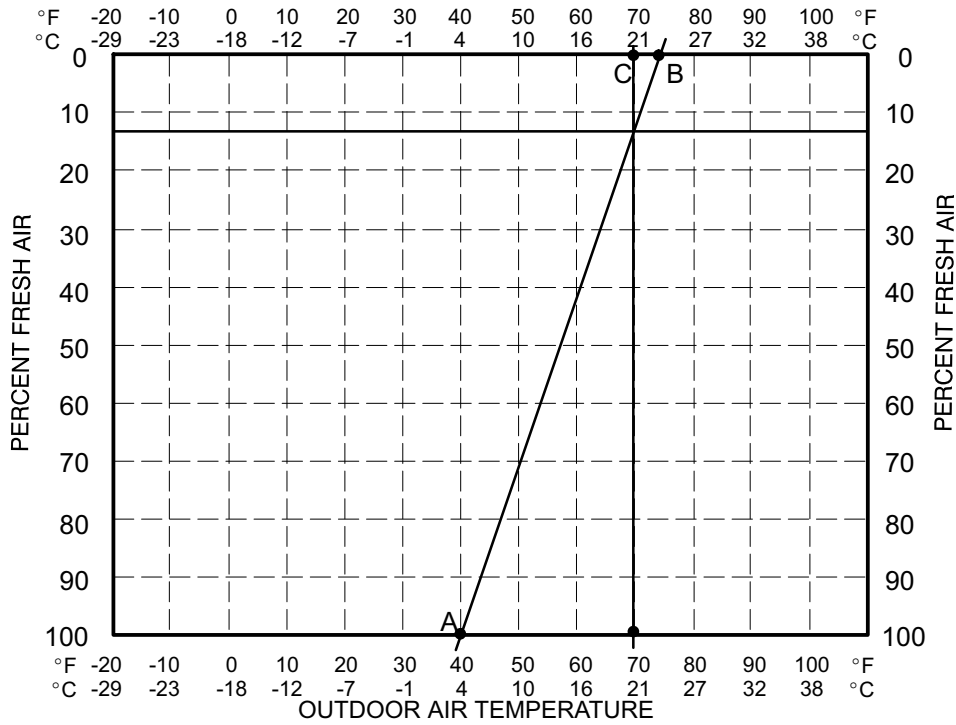
*NOTE - A jumper is factory-installed between TB1 R and OC terminals to maintain occupied status (allowing minimum fresh air). When using an electronic thermostat or energy management system with an occupied/unoccupied feature, remove jumper.*

- 1- Set thermostat to occupied mode if the feature is available. Make sure jumper is in place between TB1 terminals R and OC if using a thermostat that does not have the feature.
- 2- Rotate MIN POS SET potentiometer to approximate desired fresh air percentage.

*NOTE - Damper minimum position can be set lower than traditional minimum air requirements when an IAQ sensor is specified. Dampers will open to DCV MAX setting (if CO2 is above setpoint) to meet traditional ventilation requirements.*

- 3- Measure outdoor air temperature. Mark the point on the bottom line of chart 1 and label the point "A" (40°F, 4°C shown).
- 4- Measure return air temperature. Mark that point on the top line of chart 1 and label the point "B" (74°F, 23°C shown).
- 5- Measure mixed air (outdoor and return air) temperature. Mark that point on the top line of chart 1 and label point "C" (70°F, 21°C shown).
- 6- Draw a straight line between points A and B.
- 7- Draw a vertical line through point C.
- 8- Draw a horizontal line where the two lines meet. Read the percent of fresh air intake on the side.
- 9- If fresh air percentage is less than desired, adjust MIN POS SET potentiometer higher. If fresh air percentage is more than desired, adjust MIN POS SET potentiometer lower. Repeat steps 3 through 8 until calculation reads desired fresh air percentage.

**CHART 1  
CALCULATE MINIMUM FRESH AIR PERCENTAGE  
MIXED AND RETURN AIR TEMPERATURE**



**DCV Set and Max Settings**

Adjust settings when an optional IAQ sensor is installed.

The DCV SET potentiometer is factory-set at approximately 50% of the potentiometer range. Using a standard 1-2000ppm CO<sub>2</sub> sensor, dampers will start to open when the IAQ sensor reads approximately 1000ppm. Adjust the DCV SET potentiometer to the approximate setting specified by the controls contractor. Refer to figure 26.

The DCV MAX potentiometer is factory-set at approximately 50% of the potentiometer range or 6VDC. Dampers will open approximately half way when CO<sub>2</sub> rises above setpoint. Adjust the DCV MAX potentiometer to the approximate setting specified by the controls contractor. Refer to figure 26.

*NOTE - DCV Max must be set higher than economizer minimum position setting for proper demand control ventilation.*

**Economizer Operation**

The occupied time period is determined by the thermostat or energy management system.

**Outdoor Air Not Suitable:**

During the unoccupied time period dampers are closed.

During the occupied time period a cooling demand will open dampers to minimum position and mechanical cooling functions normally.

During the occupied time period dampers will open to DCV MAX when IAQ reading is above setpoint (regardless of thermostat demand or outdoor air suitability).

**Outdoor Air Suitable:**

See table 16 for economizer operation with a standard two-stage thermostat.

During the occupied period, dampers will open to DCV MAX when IAQ reading is above setpoint (regardless of thermostat demand or outdoor air suitability). DCV MAX will NOT override damper full-open position. When an R1 mixed air sensor for modulating dampers is installed, DCV MAX may override damper free cooling position when occupancy is high and outdoor air temperatures are low. If R1 senses discharge air temperature below 45°F (7°C), dampers will move to minimum position until discharge air temperature rises to 48°F (9°C).

**TABLE 16**

**ECONOMIZER OPERATION - OUTDOOR AIR IS SUITABLE FOR FREE COOLING – FREE COOL LED “ON”**

THERMOSTAT DEMAND	DAMPER POSITION		MECHANICAL COOLING
	UNOCCUPIED	OCCUPIED	
OFF	CLOSED	CLOSED	NO
G	CLOSED	MINIMUM	NO
Y1	OPEN*	OPEN*	NO
Y2	OPEN*	OPEN*	STAGE 1

\* Dampers will open to maintain 55°F (13°C) supply air when an R1 mixed air sensor is installed.

## B-Outdoor Air Dampers

Optional manual and motorized outdoor air dampers provide fresh outdoor air. The motorized damper assembly opens to minimum position during the occupied time period and remains closed during the unoccupied period. Manual damper assembly is set at installation and remains in that position.

Set damper minimum position in the same manner as economizer minimum position. Adjust motorized damper position using the thumbwheel on the damper motor. See figure 27. Manual damper fresh air intake percentage can be determined in the same manner.

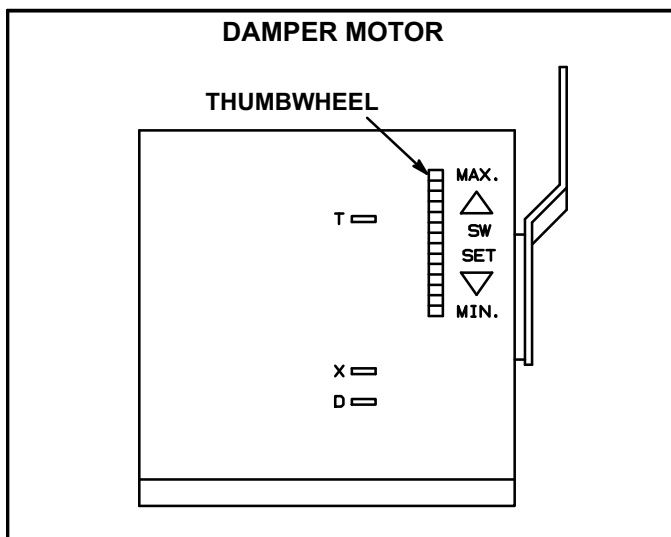


FIGURE 27

## F-Barometric Relief Dampers

Dampers are used in downflow (see figure 28) and horizontal (see figure 29) air discharge applications. Horizontal barometric relief dampers are installed in the return air duct. The dampers must be used any time an economizer and a power exhaust fan is applied to KCA/KCB series units.

Barometric relief dampers allow exhaust air to be discharged from the system when an economizer and/or power exhaust is operating. Barometric relief dampers also prevent outdoor air infiltration during unit off cycle. See installation instructions for more detail.

*NOTE- Barometric relief damper use is optional except in applications that include power exhaust dampers, where it is required..*

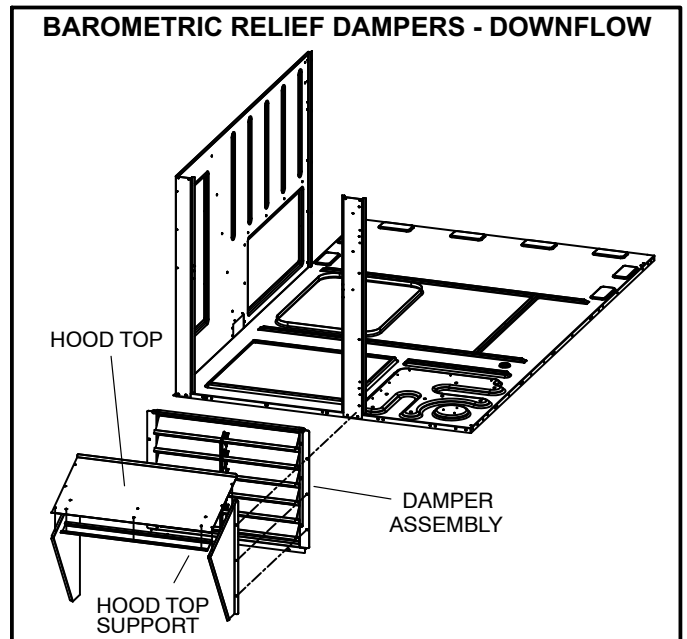


FIGURE 28

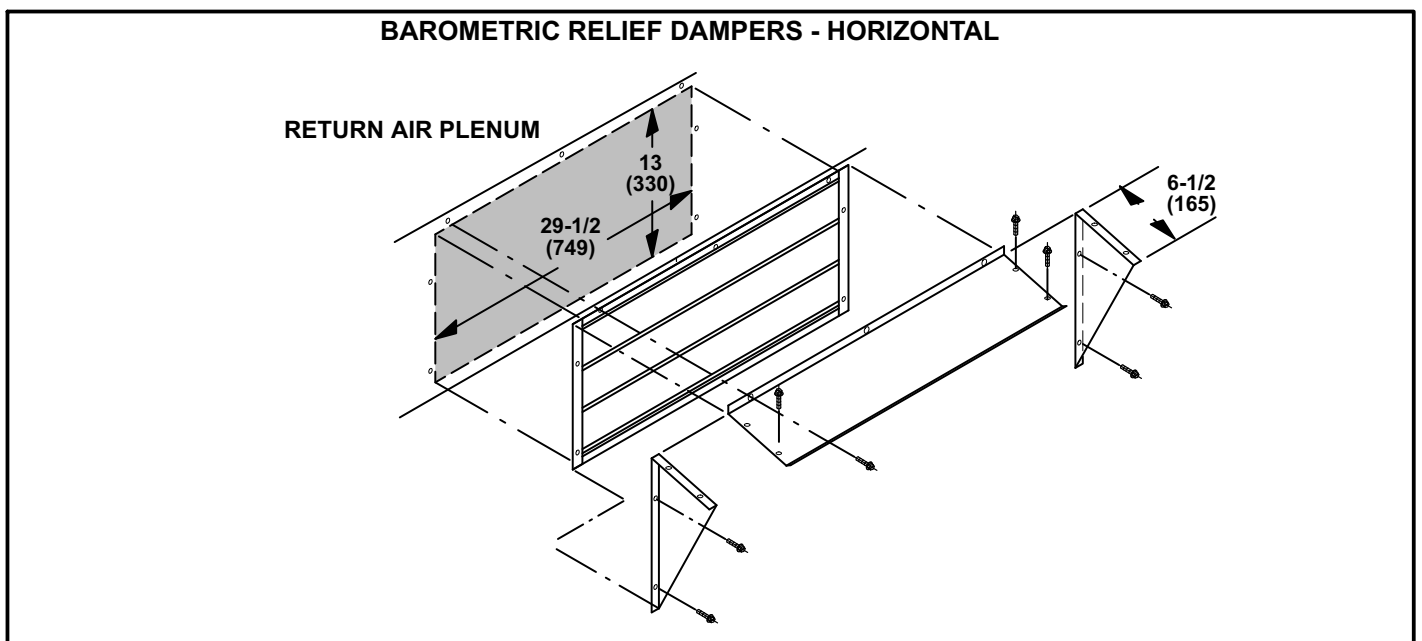


FIGURE 29

## G-Power Exhaust Fan

The power exhaust fan (K1PWRE) requires an optional barometric relief damper and economizer and is used in downflow applications only. See figure 30. The power exhaust fan provides exhaust air pressure relief and also runs when return air dampers are closed and the supply air blower is operating. See installation instructions for more detail.

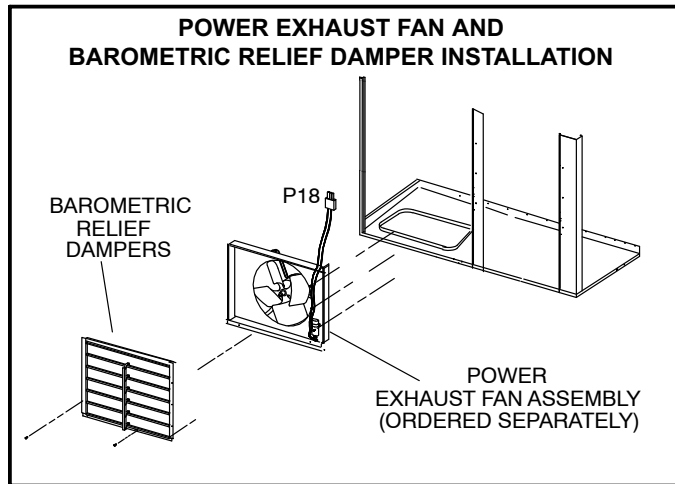


FIGURE 30

### Power Exhaust Setpoint Adjustment

Locate the A6 enthalpy control in the control area. The EXH SET potentiometer is factory-set at approximately 50% of the dial range. See figure 31. Power exhaust fans will be energized 30 seconds after dampers are 50% open. Adjust the EXH SET potentiometer higher (clockwise toward 10V) to energize fans when dampers are further open. Adjust the EXH SET potentiometer lower (counterclockwise toward 2V) to energize fans when dampers are further closed. (Thirty-second delay allows dampers to partially open before exhaust fan starts.)

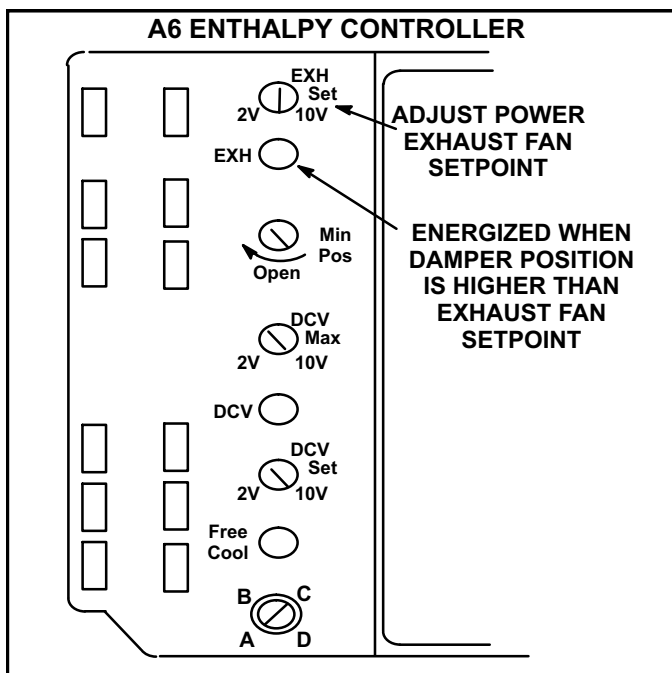


FIGURE 31

## H-Control Systems

Three different types of control systems may be used with the KCA/KCB series units. All thermostat wiring is connected to TB1 located in the control area. Each thermostat has additional control options available. See thermostat installation instructions for more detail.

### 1- Electro-mechanical thermostat (13F06)

The electro-mechanical thermostat is a two stage heat / two stage cool thermostat with dual temperature levers. A non-switching or manual system switch subbase may be used.

### 2- Electronic thermostat (see price book)

Any two stage heat / two stage cool electronic thermostat may be used.

### 3- Honeywell T7300 thermostat (60L59)

The Honeywell T7300 thermostat is a programmable, internal or optional remote temperature sensing thermostat. The T7300 provides occupied and unoccupied changeover control.

## I-Smoke Detectors A171 and A172

Photoelectric smoke detectors are a field-installed option. The smoke detectors can be installed in the supply air section (A172), return air section (A171), or in both the supply and return air section.

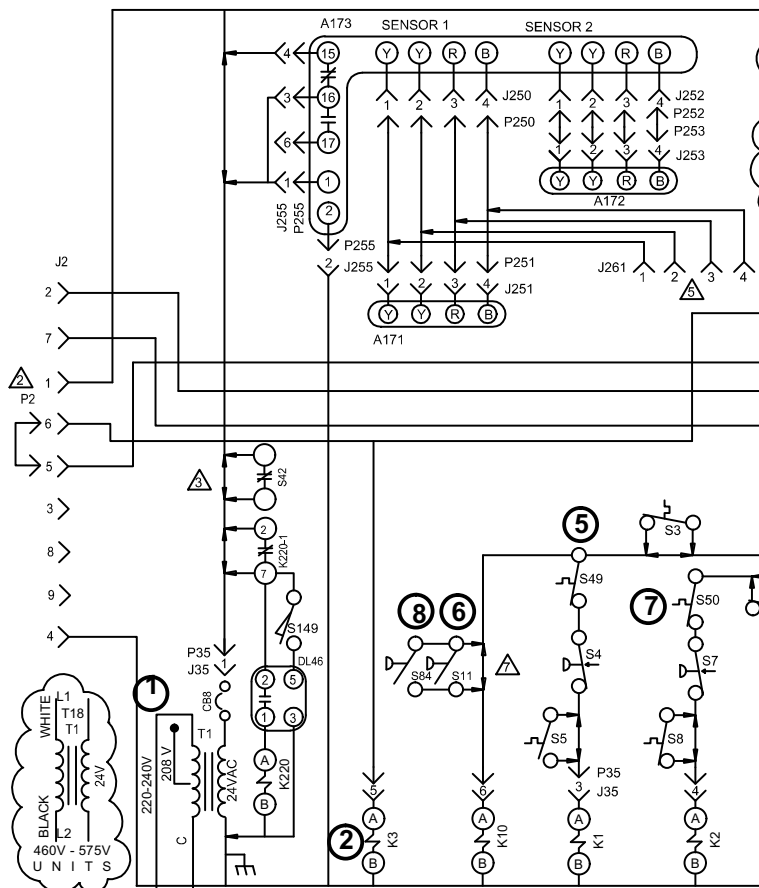
## J-Drain Pan Overflow Switch S149 (optional)

The overflow switch is used to interrupt cooling operation when excessive condensate collects in the drain pan. The normally open overflow switch is controlled by K220 and DL46 relays, located in the unit control panel. When the overflow switch closes, 24VAC power is interrupted and after a five-second delay unit compressors are de-energized. Once the condensate level drops below the set level, the switch will open. After a five-minute delay the compressor will be energized.

# VIII-Wiring Diagrams and Sequence of Operation

## KCA092/150 UNIT DIAGRAM

24V POWER



NOTE - FOR USE WITH COPPER CONDUCTORS ONLY REFER TO UNIT RATING PLATE FOR MINIMUM CIRCUIT AMPACITY AND MAXIMUM OVERCURRENT PROTECTION SIZE.

P2 IS USED ON KCA UNITS ONLY

IMPORTANT: TO PREVENT MOTOR BURNOUT, NEVER CONNECT MORE THAN ONE MOTOR LEAD TO ANY ONE CONNECTION. TAPE UNUSED MOTOR LEADS

S42 USED ON "M" VOLTAGE UNITS AND UNITS WITH HIGH EFFICIENCY MOTORS

CONNECT A172 SENSOR TO J261 ON SUPPLY AIR SMOKE DETECTOR ONLY

S48 OR CB10 MAY BE USED

JUMPER WHEN S11 AND S84 ARE NOT USED ECONOMIZER

DESCRIPTION	
KEY	COMPONENT
A42	MONITOR, PHASE PROTECTION
A144	MODULE, VOLTAGE REDUCTION

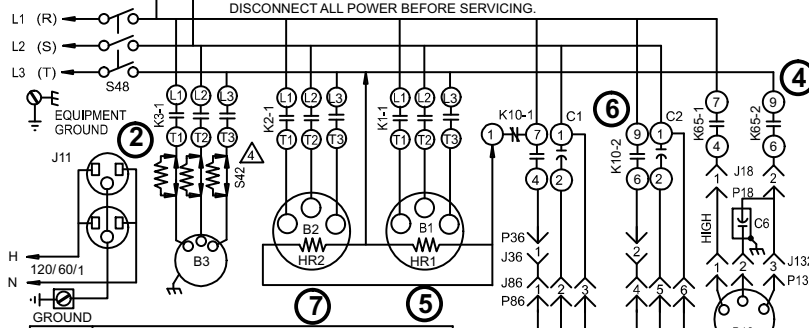
A171	SENSOR ONE, SMOKE, RETURN AIR
A172	SENSOR TWO, SMOKE, SUPPLY AIR
A173	MODULE, CONTROL SMOKE DETECTION
B1	COMPRESSOR 1
B2	COMPRESSOR 2
B3	MOTOR, BLOWER
B4	MOTOR, OUTDOOR FAN 1
B5	MOTOR, OUTDOOR FAN 2
B10	MOTOR, EXHAUST FAN 1
C1	CAPACITOR, OUTDOOR FAN 1
C2	CAPACITOR, OUTDOOR FAN 2
C6	CAPACITOR, EXHAUST FAN 1
CB8	CIRCUIT, BREAKER T1

NOTE - IF ANY WIRE IN THIS APPLIANCE REPLACED MUST BE REPLACED WITH WIRE OF LIKE SIZE, RATING, TERMINATION AND INSULATION THICKNESS

WARNING - ELECTRIC SHOCK HAZARD. CAN CAUSE INJURY OR DEATH. UNIT MUST BE GROUNDED IN ACCORDANCE WITH NATIONAL AND LOCAL CODES

DISCONNECT ALL POWER BEFORE SERVICING.

DL46	DELAY, OVERFLOW SWITCH
HR1	HEATER COMPRESSOR 1
HR2	HEATER COMPRESSOR 2
J2	JACK, HEAT
J11	JACK, GFI, RECEPTACLE
J18	JACK, EXHAUST FAN COMPT
J24	JACK, EXHAUST FAN
J35	JACK, TEST
J36	JACK, TEST COOL
J86	JACK, OUTDOOR FANS 1
J132	JACK, BLOWER, EXHAUST FAN MOTOR 1
J250	JACK, SMOKE DETECTOR ONE
J251	JACK, SMOKE DETECTOR ONE
J252	JACK, SMOKE DETECTOR TWO
J253	JACK, SMOKE DETECTOR TWO
J255	JACK, MODULE, CONTROL SMOKE DETECTION
J261	JACK, SMOKE DETECTOR JUMPER
K1,-1	CONTACTOR, COMPRESSOR 1
K2,-1	CONTACTOR, COMPRESSOR 2
K3,-1	CONTACTOR, BLOWER
K10,-1,2	RELAY, OUTDOOR FAN
K65-1,2	RELAY, EXHAUST FAN
K220,-1	RELAY, OVERFLOW DELAY
P2	JACK, HEAT
P18	PLUG, EXHAUST FAN COMPT
P24	PLUG, EXHAUST FAN
P35	JACK, TEST
P36	PLUG, TEST COOL

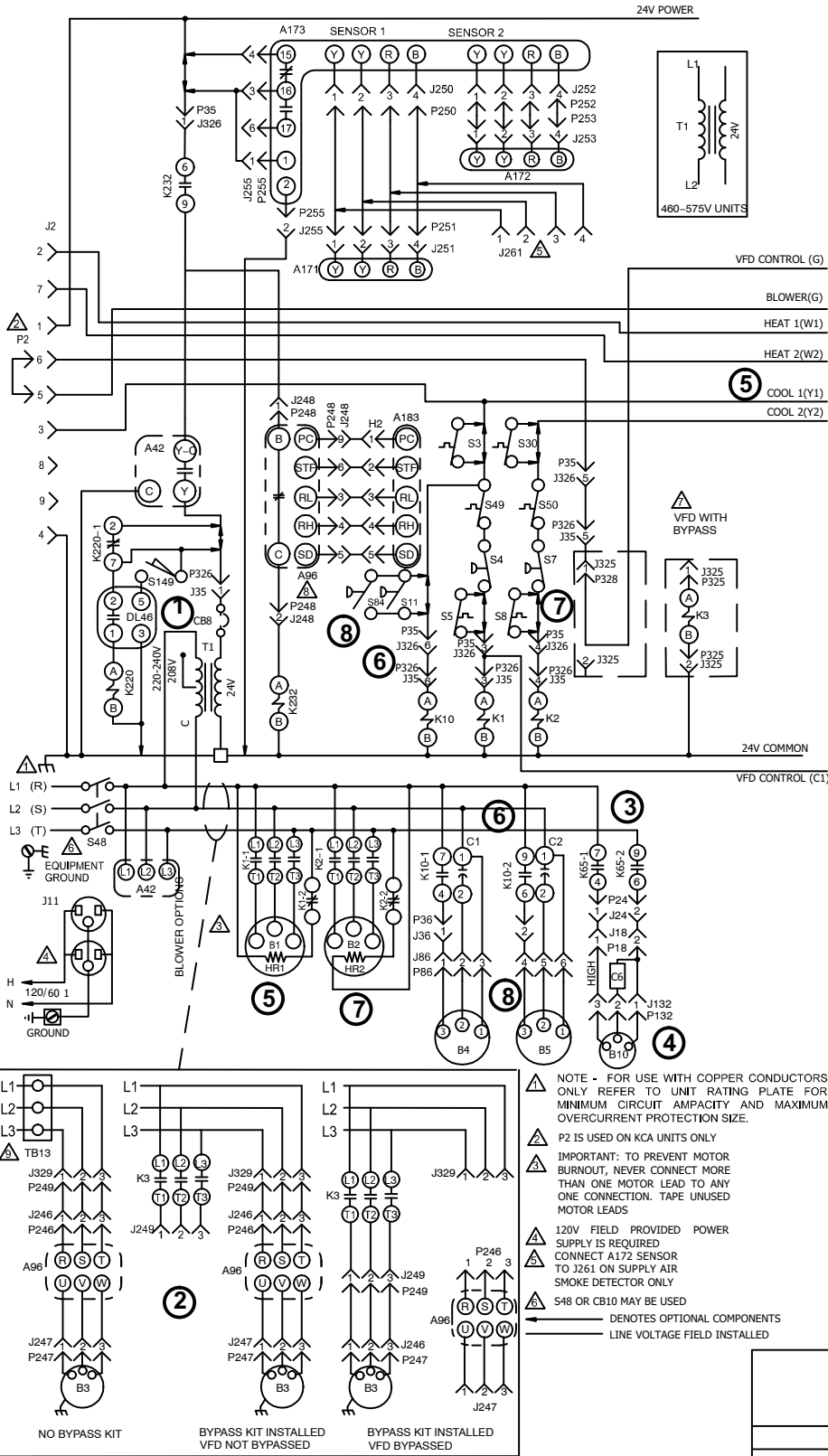


P86	PLUG, OUTDOOR FANS 1
P132	PLUG, EXHAUST FAN MOTOR 1
P250	JACK, SMOKE DETECTOR ONE
P251	JACK, SMOKE DETECTOR ONE
P252	JACK, SMOKE DETECTOR TWO
P253	JACK, SMOKE DETECTOR TWO
P255	PLUG, MODULE, CONTROL SMOKE DETECTION
S3	SWITCH, LIMIT LOW COMPRESSOR 1
S4	SWITCH, LIMIT HI PRESS COMP 1
S5	SWITCH, LIMIT HI TEMP COMPRESSOR 1
S7	SWITCH, LIMIT HI PRESS COMP 2
S8	SWITCH, LIMIT HI TEMP COMPRESSOR 2
S11	SWITCH, LOW PRESS, LOW AMBIENT KIT
S30	SWITCH, LIMIT LOW COMPRESSOR 2
S42	SWITCH, OVERLOAD RELAY BLOWER MOTOR
S48	SWITCH, DISCONNECT
S49	SWITCH, FREEZE STAT COMP 1
S50	SWITCH, FREEZE STAT COMP 2
S84	SWITCH, LOW PRESS, LOW AMBIENT KIT COMP 2
S149	SWITCH, OVERFLOW
T1	TRANSFORMER, CONTROL

← DENOTES OPTIONAL COMPONENTS  
 — LINE VOLTAGE FIELD INSTALLED

WIRING DIAGRAM		03/10
COOLING		
KCA, KGA - 092, 102, 120, 150 - G, J, M, Y		
SECTION B		REV. 0.0
Supersedes	New Form No.	537075-02

# KCA092/120 VFD UNIT DIAGRAM



KEY	COMPONENT
A42	MONITOR, PHASE PROTECTION
A96	CONTROL, INVERTER
A171	SENSOR ONE, SMOKE, RETURN AIR
A172	SENSOR TWO, SMOKE, SUPPLY AIR
A173	MODULE, CONTROL SMOKE DETECTION
A183	CONTROL, VFD BOARD
B1	COMPRESSOR 1
B2	COMPRESSOR 2
B3	MOTOR, BLOWER
B4	MOTOR, OUTDOOR FAN 1
B5	MOTOR, OUTDOOR FAN 2
B10	MOTOR, EXHAUST FAN 1
C1	CAPACITOR, OUTDOOR FAN 1
C2	CAPACITOR, OUTDOOR FAN 2
C6	CAPACITOR, EXHAUST FAN 1
CB8	CIRCUIT, BREAKER T1
DL46	DELAY, OVERFLOW SWITCH
HR1	HEATER COMPRESSOR 1
HR2	HEATER COMPRESSOR 2
J11	JACK, GFI, RECEPTACLE
K1,-1,-2	CONTACTOR, COMPRESSOR 1
K2,-1,-2	CONTACTOR, COMPRESSOR 2
K3,-1	CONTACTOR, BLOWER
K10,-1,2	RELAY, OUTDOOR FAN
K65-1,2	RELAY, EXHAUST FAN
K220,-1	RELAY, OVERFLOW DELAY
K232	RELAY, INVERTER PROTECTION
S3	SWITCH, LIMIT LOW COMPRESSOR 1
S4	SWITCH, LIMIT HI PRESS COMP 1
S5	SWITCH, LIMIT HI TEMP COMPRESSOR 1
S7	SWITCH, LIMIT HI PRESS COMP 2
S8	SWITCH, LIMIT HI TEMP COMPRESSOR 2
S11	SWITCH, LOW PRESS, LOW AMBIENT KIT
S30	SWITCH, LIMIT LOW COMPRESSOR 2
S48	SWITCH, DISCONNECT
S49	SWITCH, FREEZESTAT COMP 1
S50	SWITCH, FREEZESTAT COMP 2
S84	SWITCH, LOW PRESS, LOW AMBIENT KIT COMP 2
S149	SWITCH, OVERFLOW
T1	TRANSFORMER, CONTROL
TB13	TERMINAL STRIP, POWER DISTRIBUTION

J/P	JACK/PLUG DESCRIPTION
2	HEAT
18	EXHAUST FAN COMPT
24	EXHAUST FAN
35	TEST
36	TEST COOL
86	OUTDOOR FANS 1
132	EXHAUST FAN MOTOR 1
246	POWER TO VFD
247	POWER VFD TO MOTOR
248	VFD CONTROL
249	CONTACTOR BYPASS
250	SMOKE DETECTOR ONE
251	SMOKE DETECTOR ONE
252	SMOKE DETECTOR TWO
253	SMOKE DETECTOR TWO
255	MODULE, CONTROL SMOKE DETECTION
261	SMOKE DETECTOR JUMPER
291	VFD BYPASS LOW VOLTAGE
326	VFD CONTROL ADD-ON
328	VFD CONTROL ADD-ON
329	HI VOLTAGE VFD

NOTE - FOR USE WITH COPPER CONDUCTORS ONLY REFER TO UNIT RATING PLATE FOR MINIMUM CIRCUIT AMPACITY AND MAXIMUM OVERCURRENT PROTECTION SIZE.

P2 IS USED ON KCA UNITS ONLY

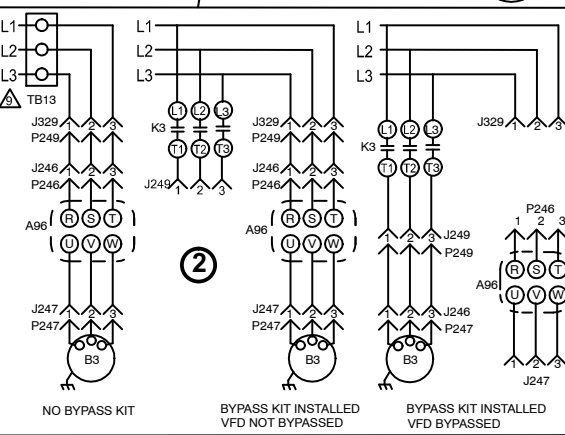
IMPORTANT: TO PREVENT MOTOR BURNOUT, NEVER CONNECT MORE THAN ONE MOTOR LEAD TO ANY ONE CONNECTION. TAPE UNUSED MOTOR LEADS

120V FIELD PROVIDED POWER SUPPLY IS REQUIRED CONNECT A172 SENSOR TO J261 ON SUPPLY AIR SMOKE DETECTOR ONLY

S48 OR CB10 MAY BE USED

⚠ DENOTES OPTIONAL COMPONENTS

⚡ LINE VOLTAGE FIELD INSTALLED



NOTE - IF ANY WIRE IN THIS APPLIANCE IS REPLACED IT MUST BE REPLACED WITH WIRE OF LIKE SIZE, RATING, TERMINATION AND INSULATION THICKNESS

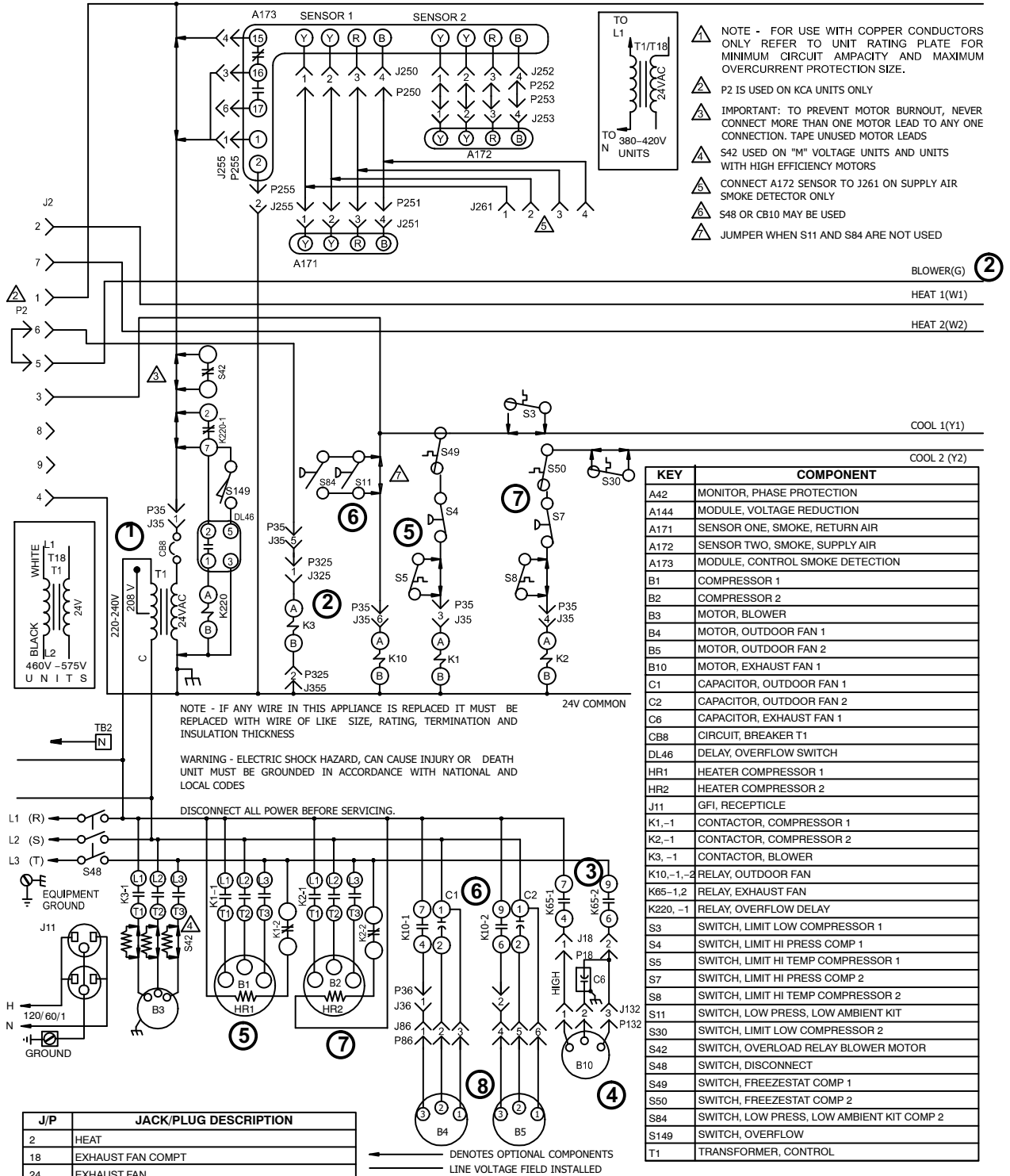
WARNING - ELECTRIC SHOCK HAZARD, CAN CAUSE INJURY OR DEATH UNIT MUST BE GROUNDED IN ACCORDANCE WITH NATIONAL AND LOCAL CODES

DISCONNECT ALL POWER BEFORE SERVICING.

WIRING DIAGRAM		09/17
COOLING		
KCA, KGA- 092, 102, 120 - G, J, Y VFD UNITS		
SECTION B		REV. 0
Supersedes 537425-02	New Form No. 537425-03	

# KCB092/120 CAV UNIT DIAGRAM

24V POWER



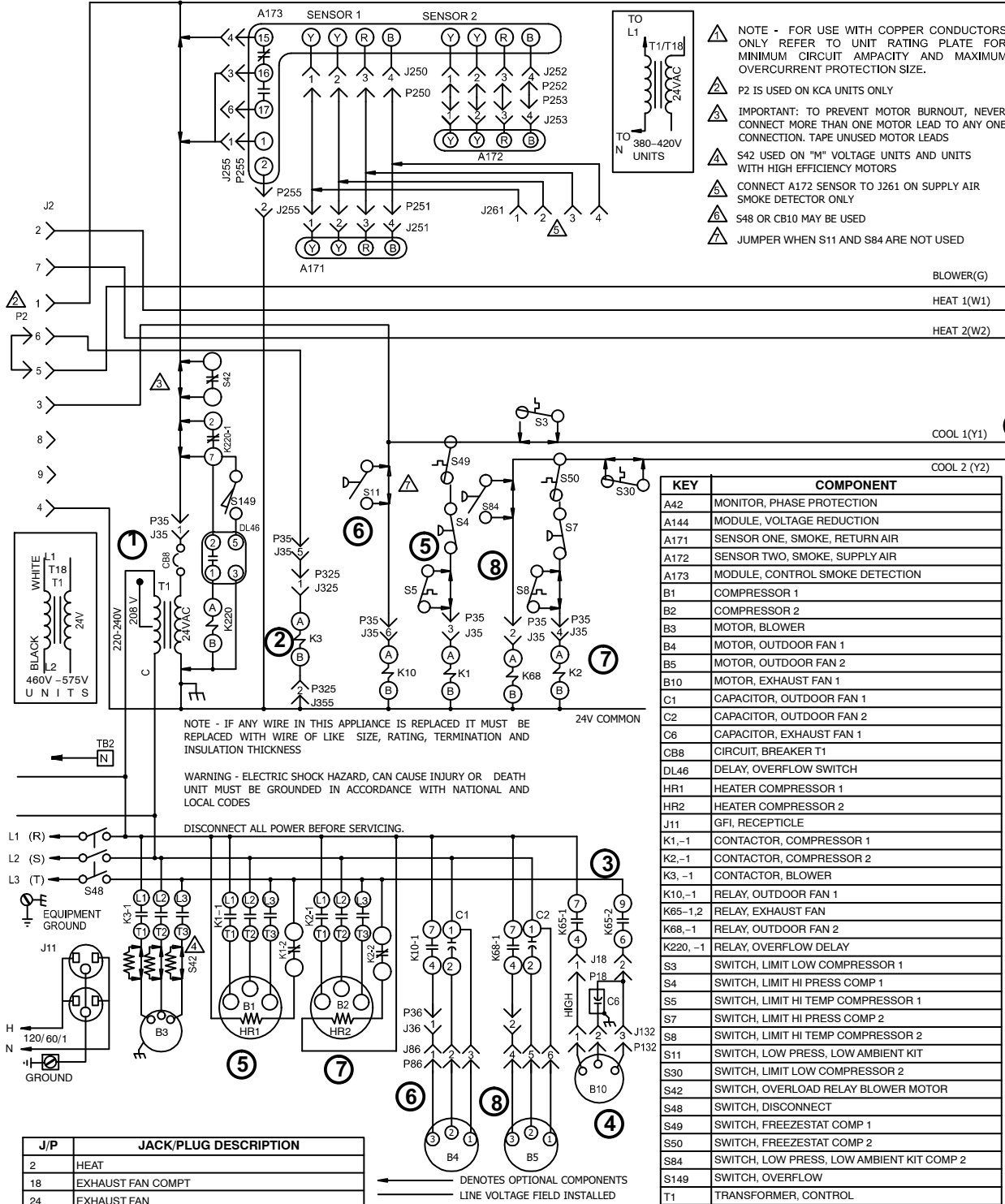
KEY	COMPONENT
A42	MONITOR, PHASE PROTECTION
A144	MODULE, VOLTAGE REDUCTION
A171	SENSOR ONE, SMOKE, RETURN AIR
A172	SENSOR TWO, SMOKE, SUPPLY AIR
A173	MODULE, CONTROL SMOKE DETECTION
B1	COMPRESSOR 1
B2	COMPRESSOR 2
B3	MOTOR, BLOWER
B4	MOTOR, OUTDOOR FAN 1
B5	MOTOR, OUTDOOR FAN 2
B10	MOTOR, EXHAUST FAN 1
C1	CAPACITOR, OUTDOOR FAN 1
C2	CAPACITOR, OUTDOOR FAN 2
C6	CAPACITOR, EXHAUST FAN 1
CB8	CIRCUIT, BREAKER T1
DL46	DELAY, OVERFLOW SWITCH
HR1	HEATER COMPRESSOR 1
HR2	HEATER COMPRESSOR 2
J11	GFI, RECEPTICLE
K1,-1	CONTACTOR, COMPRESSOR 1
K2,-1	CONTACTOR, COMPRESSOR 2
K3,-1	CONTACTOR, BLOWER
K10,-1,2	RELAY, OUTDOOR FAN
K65-1,2	RELAY, EXHAUST FAN
K220,-1	RELAY, OVERFLOW DELAY
S3	SWITCH, LIMIT LOW COMPRESSOR 1
S4	SWITCH, LIMIT HI PRESS COMP 1
S5	SWITCH, LIMIT HI TEMP COMPRESSOR 1
S7	SWITCH, LIMIT HI PRESS COMP 2
S8	SWITCH, LIMIT HI TEMP COMPRESSOR 2
S11	SWITCH, LOW PRESS, LOW AMBIENT KIT
S30	SWITCH, LIMIT LOW COMPRESSOR 2
S42	SWITCH, OVERLOAD RELAY BLOWER MOTOR
S48	SWITCH, DISCONNECT
S49	SWITCH, FREEZESTAT COMP 1
S50	SWITCH, FREEZESTAT COMP 2
S84	SWITCH, LOW PRESS, LOW AMBIENT KIT COMP 2
S149	SWITCH, OVERFLOW
T1	TRANSFORMER, CONTROL

J/P	JACK/PLUG DESCRIPTION
2	HEAT
18	EXHAUST FAN COMPT
24	EXHAUST FAN
35	TEST
36	TEST COOL
86	OUTDOOR FANS 1
132	EXHAUST FAN MOTOR 1
250	SMOKE DETECTOR ONE
251	SMOKE DETECTOR ONE
252	SMOKE DETECTOR TWO
253	SMOKE DETECTOR TWO
255	MODULE, CONTROL SMOKE DETECTION
261	SMOKE DETECTOR JUMPER
325	ASDF

WIRING DIAGRAM		09/17
COOLING - CAV		
KCB, KGB - 092, 102, 120 - G, J, M, Y		
SECTION B		REV. 0
Supersedes	New Form No.	
537075-05	537075-06	

# KCB150 CAV UNIT DIAGRAM

24V POWER



- ⚠ NOTE - FOR USE WITH COPPER CONDUCTORS ONLY REFER TO UNIT RATING PLATE FOR MINIMUM CIRCUIT AMPACITY AND MAXIMUM OVERCURRENT PROTECTION SIZE.
- ⚠ P2 IS USED ON KCA UNITS ONLY
- ⚠ IMPORTANT: TO PREVENT MOTOR BURNOUT, NEVER CONNECT MORE THAN ONE MOTOR LEAD TO ANY ONE CONNECTION. TAPE UNUSED MOTOR LEADS
- ⚠ S42 USED ON "M" VOLTAGE UNITS AND UNITS WITH HIGH EFFICIENCY MOTORS
- ⚠ CONNECT A172 SENSOR TO J261 ON SUPPLY AIR SMOKE DETECTOR ONLY
- ⚠ S48 OR CB10 MAY BE USED
- ⚠ JUMPER WHEN S11 AND S84 ARE NOT USED

KEY	COMPONENT
A42	MONITOR, PHASE PROTECTION
A144	MODULE, VOLTAGE REDUCTION
A171	SENSOR ONE, SMOKE, RETURN AIR
A172	SENSOR TWO, SMOKE, SUPPLY AIR
A173	MODULE, CONTROL SMOKE DETECTION
B1	COMPRESSOR 1
B2	COMPRESSOR 2
B3	MOTOR, BLOWER
B4	MOTOR, OUTDOOR FAN 1
B5	MOTOR, OUTDOOR FAN 2
B10	MOTOR, EXHAUST FAN 1
C1	CAPACITOR, OUTDOOR FAN 1
C2	CAPACITOR, OUTDOOR FAN 2
C6	CAPACITOR, EXHAUST FAN 1
CB8	CIRCUIT, BREAKER T1
DL46	DELAY, OVERFLOW SWITCH
HR1	HEATER COMPRESSOR 1
HR2	HEATER COMPRESSOR 2
J11	GFI, RECEIPTICLE
K1,-1	CONTACTOR, COMPRESSOR 1
K2,-1	CONTACTOR, COMPRESSOR 2
K3,-1	CONTACTOR, BLOWER
K10,-1	RELAY, OUTDOOR FAN 1
K65-1,2	RELAY, EXHAUST FAN
K68,-1	RELAY, OUTDOOR FAN 2
K220,-1	RELAY, OVERFLOW DELAY
S3	SWITCH, LIMIT LOW COMPRESSOR 1
S4	SWITCH, LIMIT HI PRESS COMP 1
S5	SWITCH, LIMIT HI TEMP COMPRESSOR 1
S7	SWITCH, LIMIT HI PRESS COMP 2
S8	SWITCH, LIMIT HI TEMP COMPRESSOR 2
S11	SWITCH, LOW PRESS, LOW AMBIENT KIT
S30	SWITCH, LIMIT LOW COMPRESSOR 2
S42	SWITCH, OVERLOAD RELAY BLOWER MOTOR
S48	SWITCH, DISCONNECT
S49	SWITCH, FREEZESTAT COMP 1
S50	SWITCH, FREEZESTAT COMP 2
S84	SWITCH, LOW PRESS, LOW AMBIENT KIT COMP 2
S149	SWITCH, OVERFLOW
T1	TRANSFORMER, CONTROL

J/P	JACK/PLUG DESCRIPTION
2	HEAT
18	EXHAUST FAN COMPT
24	EXHAUST FAN
35	TEST
36	TEST COOL
86	OUTDOOR FANS 1
132	EXHAUST FAN MOTOR 1
250	SMOKE DETECTOR ONE
251	SMOKE DETECTOR ONE
252	SMOKE DETECTOR TWO
253	SMOKE DETECTOR TWO
255	MODULE, CONTROL SMOKE DETECTION
261	SMOKE DETECTOR JUMPER
325	ASDF

WIRING DIAGRAM 09/17

COOLING - CAV

KCB, KGB - 150 - G, J, M, Y

SECTION B REV. 0

Supersedes \_\_\_\_\_ New Form No. 537895-01

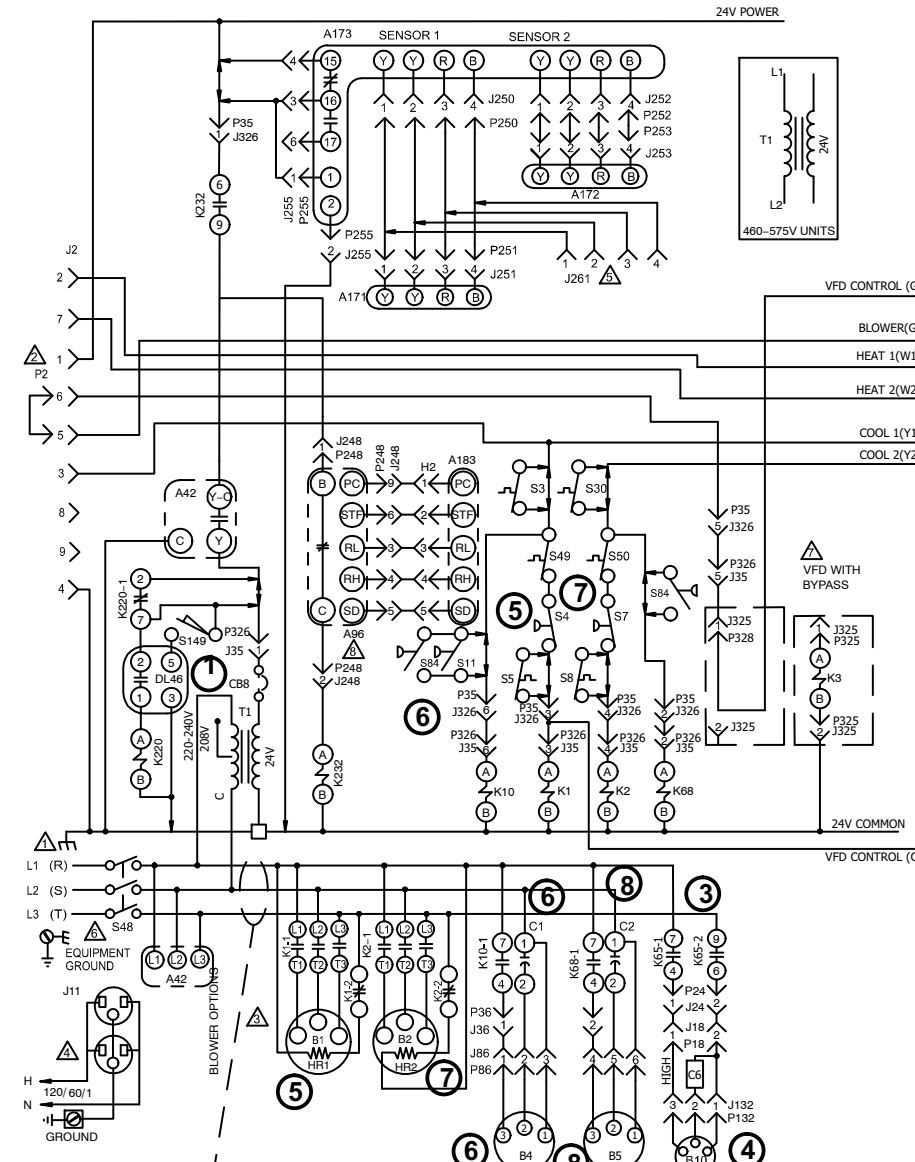
NOTE - IF ANY WIRE IN THIS APPLIANCE IS REPLACED IT MUST BE REPLACED WITH WIRE OF LIKE SIZE, RATING, TERMINATION AND INSULATION THICKNESS

WARNING - ELECTRIC SHOCK HAZARD, CAN CAUSE INJURY OR DEATH UNIT MUST BE GROUNDED IN ACCORDANCE WITH NATIONAL AND LOCAL CODES

DISCONNECT ALL POWER BEFORE SERVICING.



# KCB150 DFV UNIT DIAGRAM



KEY	COMPONENT
A42	MONITOR, PHASE PROTECTION
A96	CONTROL, INVERTER
A171	SENSOR ONE, SMOKE, RETURN AIR
A172	SENSOR TWO, SMOKE, SUPPLY AIR
A173	MODULE, CONTROL SMOKE DETECTION
A183	CONTROL, VFD BOARD
B1	COMPRESSOR 1
B2	COMPRESSOR 2
B3	MOTOR, BLOWER
B4	MOTOR, OUTDOOR FAN 1
B5	MOTOR, OUTDOOR FAN 2
B10	MOTOR, EXHAUST FAN 1
C1	CAPACITOR, OUTDOOR FAN 1
C2	CAPACITOR, OUTDOOR FAN 2
C6	CAPACITOR, EXHAUST FAN 1
CB8	CIRCUIT, BREAKER T1
DL46	DELAY, OVERFLOW SWITCH
HR1	HEATER COMPRESSOR 1
HR2	HEATER COMPRESSOR 2
J11	JACK, GFI, RECEPTACLE
K1,-1,-2	CONTACTOR, COMPRESSOR 1
K2,-1,-2	CONTACTOR, COMPRESSOR 2
K3, -1	CONTACTOR, BLOWER
K10,-1,2	RELAY, OUTDOOR FAN 1
K65-1,2	RELAY, EXHAUST FAN
K68	RELAY, OUTDOOR FAN 2
K220,-1	RELAY, OVERFLOW DELAY
K232	RELAY, INVERTER PROTECTION
S3	SWITCH, LIMIT LOW COMPRESSOR 1
S4	SWITCH, LIMIT HI PRESS COMP 1
S5	SWITCH, LIMIT HI TEMP COMPRESSOR 1
S7	SWITCH, LIMIT HI PRESS COMP 2
S8	SWITCH, LIMIT HI TEMP COMPRESSOR 2
S11	SWITCH, LOW PRESS. LOW AMBIENT KIT
S30	SWITCH, LIMIT LOW COMPRESSOR 2
S48	SWITCH, DISCONNECT
S49	SWITCH, FREEZESTAT COMP 1
S50	SWITCH, FREEZESTAT COMP 2
S84	SWITCH, LOW PRESS. LOW AMBIENT KIT COMP 2
S149	SWITCH, OVERFLOW
T1	TRANSFORMER, CONTROL
TB13	TERMINAL STRIP, POWER DISTRIBUTION

J/P	JACK/PLUG DESCRIPTION
2	HEAT
18	EXHAUST FAN COMPT
24	EXHAUST FAN
35	TEST
36	TEST COOL
86	OUTDOOR FANS 1
132	EXHAUST FAN MOTOR 1
246	POWER TO VFD
247	POWER VFD TO MOTOR
248	VFD CONTROL
249	CONTACTOR BYPASS
250	SMOKE DETECTOR ONE
251	SMOKE DETECTOR ONE
252	SMOKE DETECTOR TWO
253	SMOKE DETECTOR TWO
255	MODULE, CONTROL SMOKE DETECTION
261	SMOKE DETECTOR JUMPER
291	VFD BYPASS LOW VOLTAGE
326	VFD CONTROL ADD-ON
328	VFD CONTROL ADD-ON
329	HI VOLTAGE VFD

- NOTE - FOR USE WITH COPPER CONDUCTORS ONLY REFER TO UNIT RATING PLATE FOR MINIMUM CIRCUIT AMPACITY AND MAXIMUM OVERCURRENT PROTECTION SIZE.
- P2 IS USED ON KCA UNITS ONLY
- IMPORTANT: TO PREVENT MOTOR BURNOUT, NEVER CONNECT MORE THAN ONE MOTOR LEAD TO ANY ONE CONNECTION. TAPE UNUSED MOTOR LEADS
- 120V FIELD PROVIDED POWER SUPPLY IS REQUIRED
- CONNECT A172 SENSOR TO J261 ON SUPPLY AIR SMOKE DETECTOR ONLY
- S48 OR CB10 MAY BE USED
- DENOTES OPTIONAL COMPONENTS
- LINE VOLTAGE FIELD INSTALLED

NOTE - IF ANY WIRE IN THIS APPLIANCE IS REPLACED IT MUST BE REPLACED WITH WIRE OF LIKE SIZE, RATING, TERMINATION AND INSULATION THICKNESS  
 WARNING - ELECTRIC SHOCK HAZARD, CAN CAUSE INJURY OR DEATH UNIT MUST BE GROUNDED IN ACCORDANCE WITH NATIONAL AND LOCAL CODES  
 DISCONNECT ALL POWER BEFORE SERVICING.

WIRING DIAGRAM		11/17
COOLING		
KCB, KGB - 150 - G, J, Y VFD UNITS		
SECTION B		REV. 0
Supersedes	New Form No. 537906-01	

## KCA092/150 & KCB092/120 Sequence of Operation

### Power:

- 1- Line voltage from unit disconnect energizes transformer T1. T1 provides 24VAC power to terminal strip TB1. TB1 provides 24VAC to the unit cooling, heating and blower controls.

### Blower Operation:

- 2- *VFD units WITH a by-pass and CAV units* - Indoor thermostat terminal G energizes blower contactor K3 with 24VAC. N.O. K3 closes, energizing blower B3.  
*VFD units WITHOUT a by-pass* - Indoor blower operation is controlled by A96 inverter.

### Economizer Operation:

- 3- The economizer control module receives a demand and energizes exhaust fan relay K65 with 24VAC at 50% outside air damper open (adjustable).
- 4- N.O. K65-1 and N.O. K65-2 both close, energizing exhaust fan motor B10.

### 1st Stage Cooling (compressor B1)

- 5- First stage cooling demand Y1 and G are energized by

the thermostat. G energizes blower. 24VAC is routed through TB1 passing N.C. freeze-stat S49 and optional N.C. high pressure switch S4. Compressor contactor K1 is energized. N.O. contacts K1 close energizing compressor B1.

- 6- Optional N.O. low ambient switch S11 closes to energize condenser fan relay K10. N.O. contacts K10-1 and K10-2 close energizing condenser fans B4 and B5. N.C. contacts K10-1 open de-energizing crankcase heaters HR1 and HR2.

### 2nd Stage Cooling (compressor B2)

- 7- 24VAC is routed through TB1 and proves N.C. freeze-stat S50 and optional N.C. high pressure switch S7. Compressor contactor K2 is energized. N.O. K2 contacts close energizing compressor B2.
- 8- Optional N.O. low ambient switch S84 closes to energize condenser fan relay K10. N.O. contacts K10-1 and K10-2 close energizing condenser fans B4 and B5. N.C. contacts K10-1 open de-energizing crankcase heaters HR1 and HR2.

## KCB150 Sequence of Operation

### Power:

- 1- Line voltage from unit disconnect energizes transformer T1. T1 provides 24VAC power to terminal strip TB1. TB1 provides 24VAC to the unit cooling, heating and blower controls.

### Blower Operation:

- 2- *VFD units WITH a by-pass and CAV units* - Indoor thermostat terminal G energizes blower contactor K3 with 24VAC. N.O. K3 closes, energizing blower B3.  
*VFD units WITHOUT a by-pass* - Indoor blower operation is controlled by A96 inverter.

### Economizer Operation:

- 3- The economizer control module receives a demand and energizes exhaust fan relay K65 with 24VAC at 50% outside air damper open (adjustable).
- 4- N.O. K65-1 and N.O. K65-2 both close, energizing exhaust fan motor B10.

### 1st Stage Cooling (compressor B1)

- 5- First stage cooling demand Y1 and G are energized by

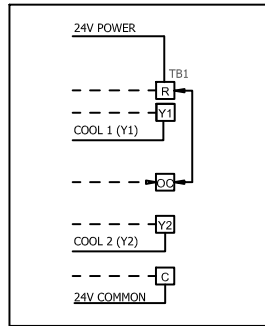
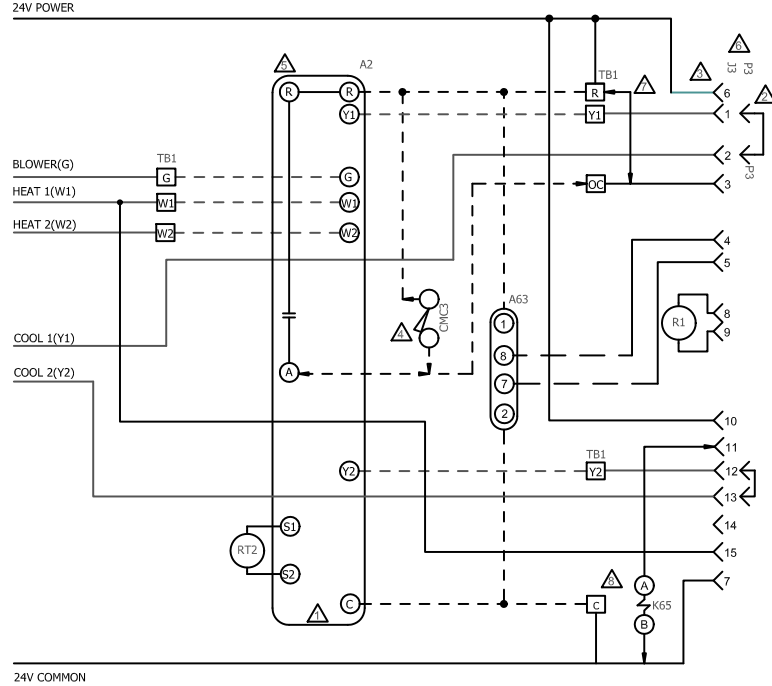
the thermostat. G energizes blower. 24VAC is routed through TB1 passing N.C. freeze-stat S49 and optional N.C. high pressure switch S4. Compressor contactor K1 is energized. N.O. contacts K1-1 close energizing compressor B1. N.C. Contacts K1-2 open de-energizing crankcase heater HR1

- 6- Optional N.O. low ambient switch S11 closes to energize condenser fan relay K10. N.O. contacts K10-1 close energizing condenser fan B4.

### 2nd Stage Cooling (compressor B2)

- 7- 24VAC is routed through TB1 and proves N.C. freeze-stat S50 and optional N.C. high pressure switch S7. Compressor contactor K2 is energized. N.O. K2 contacts close energizing compressor B2. N.C.K2-2 opens de-energizing crankcase heater HR2.
- 8- Optional N.O. low ambient switch S84 closes to energize condenser fan relay K68. N.O. contacts K68-1 close energizing condenser fan B5.

# ELECTRONIC OR ELECTROMECHANICAL THERMOSTAT



CONNECTION SCHEME FOR KCA, KGA AND KHA  
092 THROUGH 150 UNITS WITHOUT  
ECONOMIZER ONLY

KEY	COMPONENT
A2	SENSOR, ELECTRONIC THERMOSTAT
A63	SENSOR, CO2
CMC3	CLOCK, TIME
J3	JACK, UNIT ECONOMIZER
K65	RELAY, EXHAUST FAN
P3	PLUG, ECONOMIZER BYPASS
R1	SENSOR, MIXED AIR OR SUPPLY AIR
RT2	SENSOR, REMOTE THERMOSTAT
TB1	TERMINAL STRIP, CLASS II VOLTAGE

- △ THERMOSTAT SUPPLIED BY USER
- △ REMOVE P3 WHEN ECONOMIZER IS USED
- △ J3 MAXIMUM LOAD 20VA 24VAC CLASS II
- △ TIME CLOCK CONTACTS (OPT) CLOSED OCCUPIED
- △ TOUCHSCREEN THERMOSTAT
- △ J3 AND P3 ARE NOT USED ON KCA, KGA AND KHA 092 THROUGH 150 UNITS WITHOUT ECONOMIZER
- △ REMOVE JUMPER BETWEEN TB1-R AND TB1-OCP WHEN USING A NITE SETBACK THERMOSTAT
- △ 092 TO 300 UNITS ONLY
- DENOTES OPTIONAL COMPONENTS
- - - CLASS II FIELD WIRING

08/16		WIRING DIAGRAM	08/16
		537641-01	
CONTROL			
ELECTRONIC/ELECTROMECHANICAL THERMOSTAT			
SECTION C			REV 1
Supersedes	New Form No.		
537612-01	537641-01		

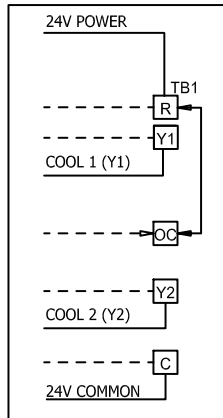
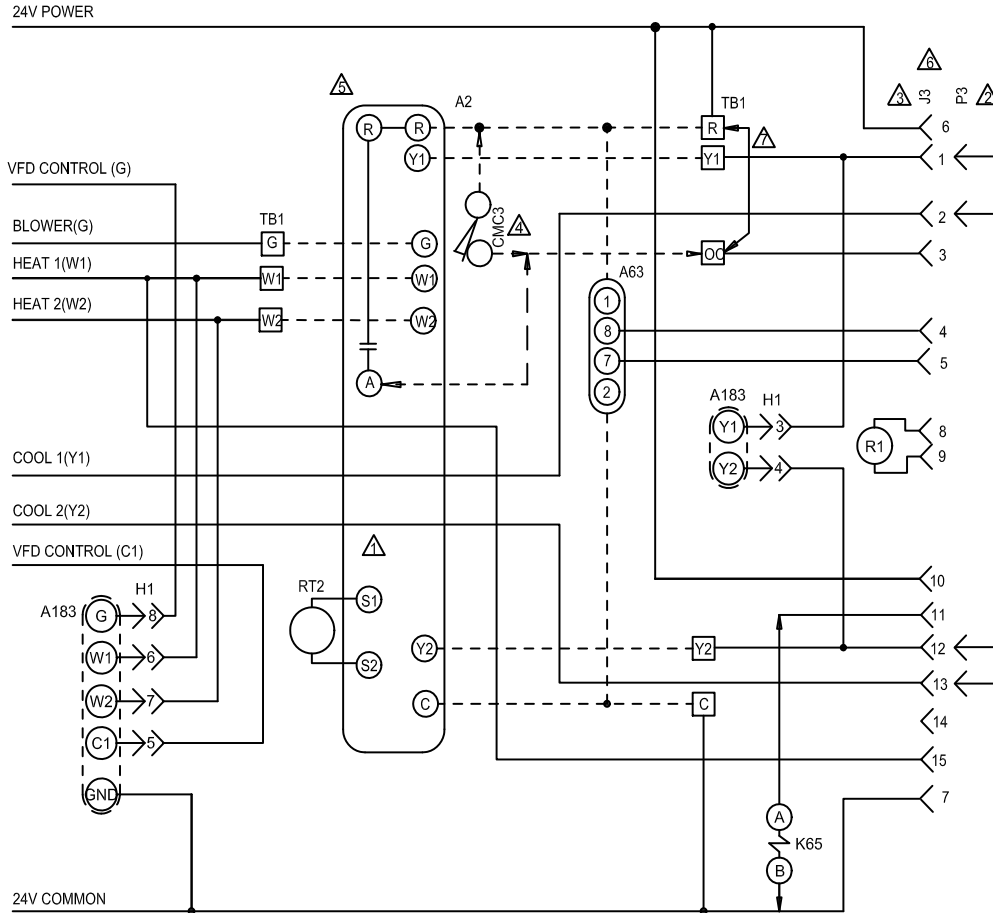
## POWER:

- 1- Terminal strip TB1 energizes thermostat components with 24VAC.

## OPERATION:

- 2- TB1 receives data from the electronic thermostat A2 (Y1, Y2, W1, W2, G, OCP). The 24VAC signal from TB1 energizes the appropriate components for heat or cool demand.

# ELECTRONIC OR ELECTROMECHANICAL THERMOSTAT



CONNECTION SCHEME FOR KCA, KGA, AND KHA 092 THROUGH 150 UNITS WITHOUT ECONOMIZER ONLY

KEY	COMPONENT
A2	SENSOR, ELECTRONIC
A63	SENSOR, CO2
A183	CONTROL, VFD BOARD
CMC3	CLOCK, TIME
H1	HEADER 1 ON VFD BOARD
J3	JACK, UNIT ECONOMIZER
K65	RELAY, EXHAUST FAN
P3	PLUG, LESS ECONOMIZER
R1	SENSOR, MIXED / SUPPLY AIR
RT2	SENSOR, REMOTE THERMOSTAT
TB1	TERMINAL STRIP, CLASS II VOLTAGE

- ⚠ THERMOSTAT SUPPLIED BY USER
- ⚠ REMOVE P3 WHEN ECONOMIZER IS USED; ONLY ON KCA, KGA AND KHA 156 THRU 300 UNITS
- ⚠ J3 MAXIMUM LOAD 20VA 24VAC CLASS II
- ⚠ TIME CLOCK CONTACTS (OPT) CLOSED OCCUPIED
- ⚠ TOUCHSCREEN THERMOSTAT
- ⚠ J3 AND P3 ARE NOT USED ON KCA, KGA, AND KHA 092 THRU 150 UNITS WITHOUT ECONOMIZER
- ⚠ REMOVE JUMPER BETWEEN TB1-R AND TB1-OC WHEN USING A NITE SETBACK THERMOSTAT

537642-01	WIRING DIAGRAM	06/13
	537642-01	
CONTROL - VFD		
ELECTRONIC/ELECTROMECHANICAL THERMOSTAT		
SECTION C		REV 0
Supersedes 537615-01	New Form No. 537642-01	

————— DESIGNATES OPTIONAL WIRING  
 - - - - - CLASS II FIELD WIRING

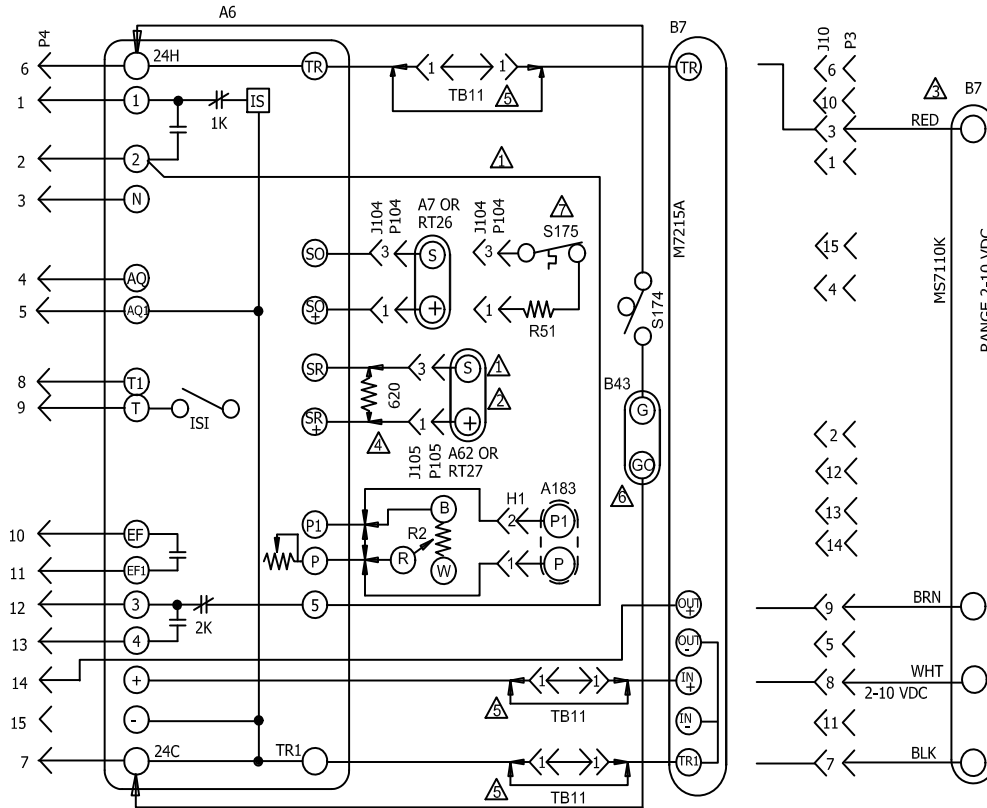
**POWER:**

- Terminal strip TB1 energizes thermostat components with 24VAC.

**OPERATION:**

- TB1 receives data from the electronic thermostat A2 (Y1, Y2, W1, W2, G, OCP). The 24VAC signal from TB1 energizes the appropriate components for heat or cool demand.

# ECONOMIZER



KEY	COMPONENT
A6	CONTROL-SOLID STATE ENTHALPY
A7	SENSOR-SOLID STATE ENTHALPY
A62	SENSOR-ENTHALPY, INDOOR
A183	CONTROL_VFD BOARD
B7	MOTOR-DAMPER, ECONOMIZER
B43	MOTOR-EXHAUST DAMPER
H1	HEADER 1 ON LANDMARK VFD BOARD
J10	JACK-ECONOMIZER
J104	JACK-SENSOR, OUTDOOR ENTHALPY
J105	JACK-SENSOR, RETURN AIR ENTHALPY
P3	PLUG-LESS ECONOMIZER
P4	PLUG-ECONOMIZER
P104	PLUG-SENSOR, OUTDOOR ENTHALPY
P105	PLUG-SENSOR, RETURN AIR ENTHALPY
R2	POT-MINIMUM POSITION
R51	RESISTOR-SENSIBLE 820 OHM
RT26	SENSOR-OUTDOOR AIR TEMP
RT27	SENSOR-INDOOR AIR TEMP
S175	THERMOSTAT-SENSIBLE TEMP 55-70F
S174	SWITCH-EXHAUST DAMPER
TB11	TERMINAL STRIP-CLASS II VOLT

DESIGNATES OPTIONAL WIRING  
 CLASS II FIELD WIRING

- RT26 AND RT27, TEMPERATURE SENSORS MAY BE USED INSTEAD OF A7 AND A62 ENTHALPY SENSORS
- A62 ENTHALPY SENSOR OR RT27 USED FOR DIFFERENTIAL SENSING
- USED ON C BOX UNITS
- REPLACE A7 OR RT26 WITH 620 OHM RESISTOR FOR CONTROLS WITH GLOBAL ECON
- TB11 USED ON "C" BOX ONLY WITH MOTOR M7215A
- OPTIONAL EXHAUST DAMPER TO HOLD EXHAUST DAMPER CLOSED WHEN OUTSIDE AIR DAMPER IS CLOSED
- OPTIONAL OUTDOOR THERMOSTAT TO REPLACE RT26 SENSIBLE SENSOR

	LANDMARK WIRING DIAGRAM	11/11
ACCESSORIES		
ECONOMIZER		
SECTION D		REV 0
Supersedes	New Form No.	537080-02
© 2011		Lennox Commercial

## SEQUENCE OF OPERATION

### POWER:

- Terminal strip TB1 energizes the economizer components with 24VAC.

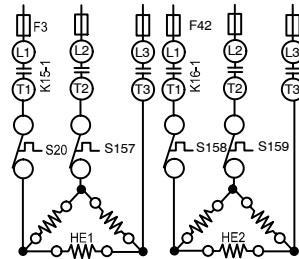
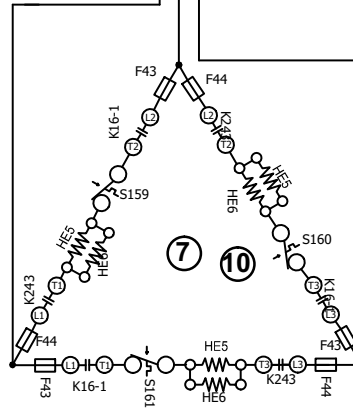
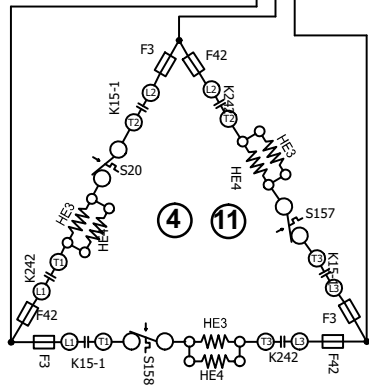
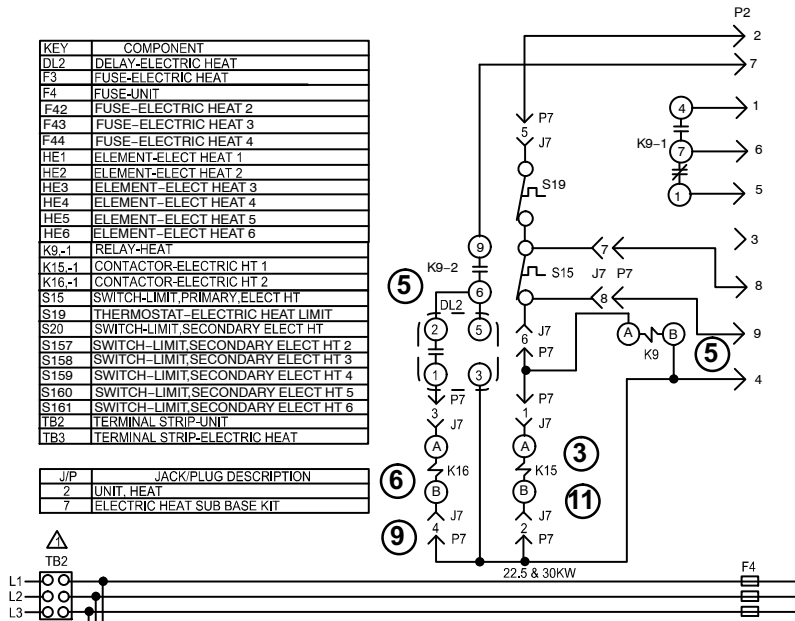
### OPERATION:

- Enthalpy sensor A7 and A62 (if differential enthalpy is used) communicates to the economizer control module A6 when to power the damper motor B7.
- Economizer control module A6 supplies B7 with 0 - 10 VDC to control the positioning of economizer.
- The damper actuator provides 2 to 10 VDC position feedback.

# EHA-7.5, 15, 22.5, 30, 45 & 60kW Y VOLTAGE KCA/KCB SERIES UNITS

KEY	COMPONENT
DL2	DELAY-ELECTRIC HEAT
F3	FUSE-ELECTRIC HEAT
F4	FUSE-UNIT
F42	FUSE-ELECTRIC HEAT 2
F43	FUSE-ELECTRIC HEAT 3
F44	FUSE-ELECTRIC HEAT 4
HE1	ELEMENT-ELECT HEAT 1
HE2	ELEMENT-ELECT HEAT 2
HE3	ELEMENT-ELECT HEAT 3
HE4	ELEMENT-ELECT HEAT 4
HE5	ELEMENT-ELECT HEAT 5
HE6	ELEMENT-ELECT HEAT 6
K9-1	RELAY-HEAT
K15-1	CONTACTOR-ELECTRIC HT 1
K16-1	CONTACTOR-ELECTRIC HT 2
S15	SWITCH-LIMIT PRIMARY ELECT HT
S19	THERMOSTAT-ELECTRIC HEAT LIMIT
S20	SWITCH-LIMIT SECONDARY ELECT HT
S157	SWITCH-LIMIT SECONDARY ELECT HT 2
S158	SWITCH-LIMIT SECONDARY ELECT HT 3
S159	SWITCH-LIMIT SECONDARY ELECT HT 4
S160	SWITCH-LIMIT SECONDARY ELECT HT 5
S161	SWITCH-LIMIT SECONDARY ELECT HT 6
TB2	TERMINAL STRIP-UNIT
TB3	TERMINAL STRIP-ELECTRIC HEAT

J/P	JACK/PLUG DESCRIPTION
2	UNIT HEAT
7	ELECTRIC HEAT SUB BASE KIT



TB2,S48 OR CB10 MAY BE USED  
 TB3 IS USED ON SOME UNITS

KW	HE1	HE2	HE3	HE4	HE5	HE6
7.5	7.5					
15	15					
22.5	15	7.5				
30	15	15				
45	15			15	15	
60			15	15	15	15

WIRING DIAGRAM		11/17
HEATING - ELECTRIC		
7.5, 15, 22.5, 30, 45, 60 - Y		
SECTION A		REV 3
Supersedes	New Form No. 537058-02	

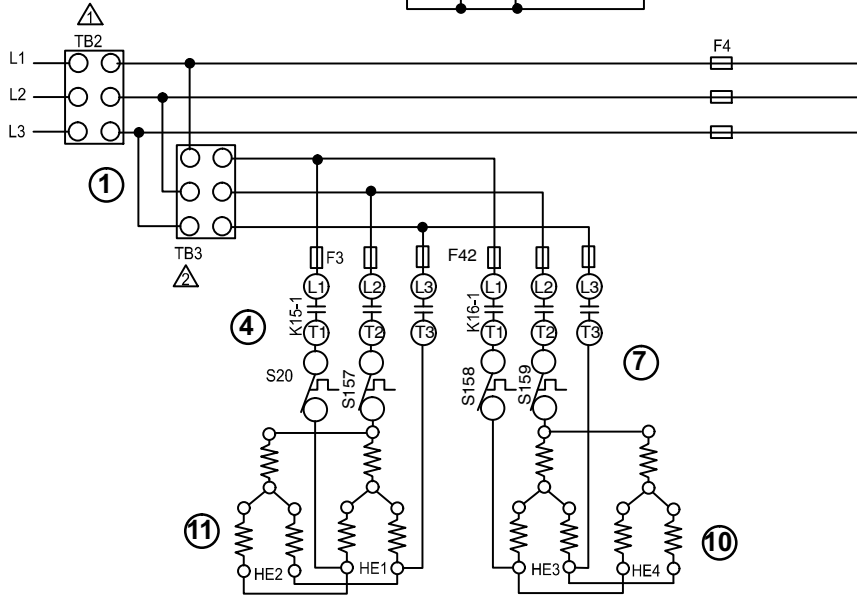
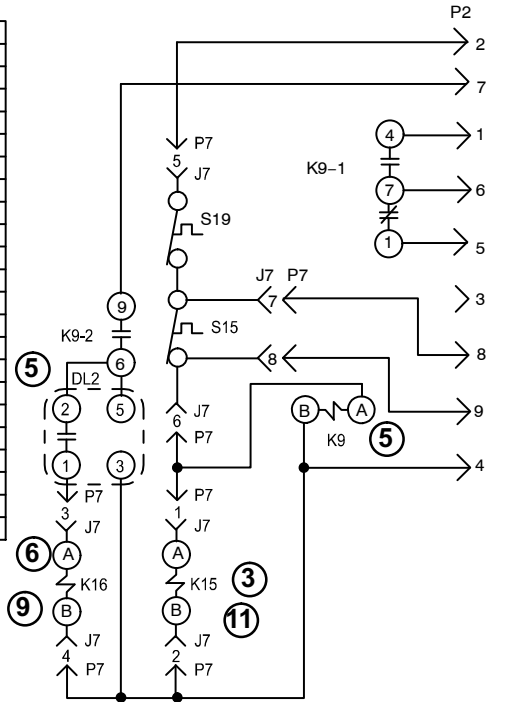
© 2012

Lennox Commercial

# EHA-7.5, 15, 22.5, 30, 45 & 60kW G, J VOLTAGE KCA/KCB SERIES UNITS

KEY	COMPONENT
DL2	DELAY-ELECTRIC HEAT
F3	FUSE-ELECTRIC HEAT
F4	FUSE-UNIT
F42	FUSE-ELECTRIC HEAT 2
HE1	ELEMENT-ELECTRIC HEAT 1
HE2	ELEMENT-ELECTRIC HEAT 2
HE3	ELEMENT-ELECTRIC HEAT 3
HE4	ELEMENT-ELECTRIC HEAT 4
J7	JACK-ELECT HT SUB-BUS KIT
K9,-1,2	RELAY-HEAT
K15,-1	CONTACTOR-ELECTRIC HEAT 1
K16,-1	CONTACTOR-ELECTRIC HEAT 2
P2	PLUG-HEAT
P7	PLUG-ELECT HT SUB-BASE KIT
S15	SWITCH LIMIT, PRIMARY, ELECT HT
S19	THERMOSTAT-ELECTRIC HEAT LIMIT
S20	SWITCH-LIMIT, SECONDARY ELECT HT
S157	SWITCH LIMIT, SECONDARY ELECT HT 2
S158	SWITCH LIMIT, SECONDARY ELECT HT 3
S159	SWITCH LIMIT, SECONDARY ELECT HT 4
TB2	TERMINAL STRIP-UNIT
TB3	TERMINAL STRIP-ELECTRIC HEAT

⚠ TB2,S48 OR CB10 MAY BE USED  
 ⚠ TB3 IS USED ON SOME UNITS



	KW	HE1	HE2	HE3	HE4
G, J	7.5	7.5			
	15	15			
	22.5	15		7.5	
	30	15		15	
	45	15		15	15
	60	15	15	15	15
M	5.7	5.7			
	11.5	11.5			
	17.2	11.5		5.7	
	23	11.5		11.5	
	34.5	11.5		11.5	11.5
	45.9	11.5	11.5	11.5	11.5

WIRING DIAGRAM		11/17
HEATING-ELECTRIC		
7.5, 15, 22.5, 30, 45, 60 - G, J 5.7, 11.5, 17.2, 23, 34.5, 45.9 - M		
HEATING SECTION-A4		REV. 2
Supersedes	New Form No.	
537057-02, 537357-02	537057-03	

© 2010

Lennox Commercial

## Sequence of Operation -EHA 7.5, 15, 22.5, 30, 45, 60 kW - Y and G, J, M

*NOTE: This sequence of operation is for all Electric Heat kW ratings Y through J voltages. Each step of operation is numbered and can be followed in sequence on the diagrams. Operation for G, J, and M voltages will be the same.*

### HEATING ELEMENTS:

- 1- Terminal Strip TB3 is energized when the unit disconnect closes. TB3 supplies line voltage to electric heat elements HE1 through HE7. Each element is protected by fuse F3.

### SECOND STAGE HEAT:

- 2- Heating demand initiates at W1 in thermostat.
- 3- 24VAC W2 signal is routed through from the thermostat to TB1. After S15 normally closed primary limit and S20 secondary limit is proved, the electric heat contactor K15 is energized.