

KHA180 and 240

KHA180 and 240 packaged heat pump units are available in 178,000 to 220,000 Btuh (55.1 to 64.5kW) heating outputs and 15 or 20-ton (52.8 or 70.3kW) cooling capacities. Units utilize two compressors, two reversing valves and other parts common to a heat pump.

Optional electric heat is field-installed. Electric heat operates in single or multiple stages depending on the kW input size. 15kW to 60kW heat sections are available for 180 units and 15kW to 90kW heat sections are available for 240 units.

Units are designed to accept any of several different energy management thermostat control systems with minimum field wiring.

Information contained in this manual is intended for use by qualified service technicians only. All specifications are subject to change. Procedures outlined in this manual are presented as a recommendation only and do not supersede or replace local or state codes.

If the unit must be lifted for service, rig unit by attaching four cables to the holes located in the unit base rail (two holes at each corner). Refer to the installation instructions for the proper rigging technique.

ELECTROSTATIC DISCHARGE (ESD)
Precautions and Procedures

CAUTION

Electrostatic discharge can affect electronic components. Take precautions during unit installation and service to protect the unit's electronic controls. Precautions will help to avoid control exposure to electrostatic discharge by putting the furnace, the control and the technician at the same electrostatic potential. Neutralize electrostatic charge by touching hand and all tools on an unpainted unit surface, such as the gas valve or blower deck, before performing any service procedure.

CAUTION

Danger of sharp metallic edges. Can cause injury. Take care when servicing unit to avoid accidental contact with sharp edges.



IMPORTANT

The Clean Air Act of 1990 bans the intentional venting of refrigerant (CFC's and HCFC's) as of July 1, 1992. Approved methods of recovery, recycling or reclaiming must be followed. Fines and/or incarceration may be levied for non-compliance.

WARNING



Electric shock hazard. Can cause injury or death. Before attempting to perform any service or maintenance, turn the electrical power to unit OFF at disconnect switch(es). Unit may have multiple power supplies.

Table of Contents

Options / Accessories Page 2
Specifications Page 5
Blower Data Page 6
Electrical / Electric Heat Data Page 9
Electric Heat Capacities Page 11
Parts Arrangement Page 12
I Unit Components Page 13
 Control Box Page 13
 Cooling Page 17
 Blower Compartment Page 18
 Electric Heat Page 21
II Placement and Installation Page 24
III Start Up Page 24
IV Charging Page 25
V System Service Checks Page 26
VI Maintenance Page 26
VII Accessories Page 27
VIII Diagrams Page 34

OPTIONS / ACCESSORIES

Item Description	Model Number	Catalog Number	180	240
COOLING SYSTEM				
Condensate Drain Trap	PVC - LTACDKP09/36	76M18	X	X
	Copper - LTACDKC09/36	76M19	X	X
Corrosion Protection		Factory	O	O
Drain Pan Overflow Switch	K1SNSR71C-1-	68W89	X	X
Efficiency		Standard	O	O
Low Ambient Kit	K1SNSR33CS1	55W73	X	X
Refrigerant Type		R-410A	O	O
BLOWER - SUPPLY AIR				
Motors	Belt Drive - 3 hp	Factory	O	
	Belt Drive - 5 hp	Factory	O	O
	Belt Drive - 7.5 hp	Factory	O	O
	Belt Drive - 10 hp	Factory		O
Drive Kits See Blower Data Tables for usage and selection	Kit #1 535-725 rpm	Factory	O	
	Kit #2 710-965 rpm	Factory	O	
	Kit #3 685-856 rpm	Factory	O	O
	Kit #4 850-1045 rpm	Factory	O	O
	Kit #5 945-1185 rpm	Factory	O	O
	Kit #6 850-1045 rpm	Factory	O	O
	Kit #7 945-1185 rpm	Factory	O	O
	Kit #8 1045-1285 rpm	Factory	O	O
	Kit #10 1045-1285 rpm	Factory		O
	Kit #11 1135-1365 rpm	Factory		O
	CABINET			
Coil Guards	C1GARD20C-1-	88K55	X	X
Hail Guards	C1GARD10C-1-	88K28	X	X
CONTROLS				
Commercial Controls	L Connection® Building Automation System	- - -	X	X
Smoke Detector - Supply or Return (Power board and one sensor)	C1SNSR44C-1	53W82	X	X
Smoke Detector - Supply and Return (Power board and two sensors)	C1SNSR43C-1	53W83	X	X
INDOOR AIR QUALITY				
Air Filters				
Healthy Climate® High Efficiency Air Filters 24 x 24 x 2 (Order 6 per unit)	MERV 8 - C1FLTR15C-1-	54W67	X	X
	MERV 13 - C1FLTR40C-1-	52W40	X	X
Replacement Media Filter With Metal Mesh Frame (includes non-pleated filter media)	C1FLTR30C-1-	44N61	X	X
Indoor Air Quality (CO₂) Sensors				
Sensor - Wall-mount, off-white plastic cover with LCD display	C0SNSR50AE1L	77N39	X	X
Sensor - Wall-mount, off-white plastic cover, no display	C0SNSR52AE1L	87N53	X	X
Sensor - Black plastic case with LCD display, rated for plenum mounting	C0SNSR51AE1L	87N52	X	X
Sensor - Wall-mount, black plastic case, no display, rated for plenum mounting	C0MISC19AE1	87N54	X	X
CO ₂ Sensor Duct Mounting Kit - for downflow applications	C0MISC19AE1-	85L43	X	X
Aspiration Box - for duct mounting non-plenum rated CO ₂ sensors (87N53 or 77N39)	C0MISC16AE1-	90N43	X	X
UVC Germicidal Light Kit				
¹ Healthy Climate® UVC Light Kit (110/230v-1ph)	C1UVCL10C-1	54W65	X	X

¹ Lamps operate on 110-230V single-phase power supply. Step-down transformer must be field supplied for field installation in 460V and 575V rooftop units (transformer is furnished for factory installed light kits). Alternately, a separate 110V power supply may be used to directly power the UVC ballast(s)

NOTE - Catalog and model numbers shown are for ordering field installed accessories.

OX - Configure To Order (Factory Installed) or Field Installed

O = Configure To Order (Factory Installed)

X = Field Installed

OPTIONS / ACCESSORIES

Item Description	Model Number	Catalog Number	180	240
ELECTRICAL				
Voltage 60 hz	208/230V - 3 phase	Factory	O	O
	460V - 3 phase	Factory	O	O
	575V - 3 phase	Factory	O	O
Disconnect Switch (see Electric Heat Tables for usage,)	80 amp - C1DISC080C-1	54W85	OX	OX
	150 amp - C1DISC150C-1	54W86	OX	OX
	250 amp - C1DISC250C-1	54W87	OX	OX
GFI Service Outlets	Field wired - LTAGFIK10/15	74M70	OX	OX
ELECTRIC HEAT				
15 kW	208/230V-3ph - C1EH0150C-1Y	53W84	X	X
	460V-3ph - C1EH0150C-1G	53W86	X	X
	575V-3ph - C1EH0150C-1J	53W87	X	X
30 kW	208/230V-3ph - C1EH0300C21Y	53W92	X	X
	460V-3ph - C1EH0300C21G	53W94	X	X
	575V-3ph - C1EH0300C21J	53W95	X	X
45 kW	208/230V-3ph - C1EH0450C21Y	54W00	X	X
	460V-3ph - C1EH0450C21G	54W02	X	X
	575V-3ph - C1EH0450C21J	54W03	X	X
60 kW	208/230V-3ph - C1EH0600C21Y	54W08	X	X
	460V-3ph - C1EH0600C21G	54W10	X	X
	575V-3ph - C1EH0600C21J	54W11	X	X
90 kW	208/230V-3ph - C1EH0900C-1Y	54W12		X
	460V-3ph - C1EH0900C-1G	54W14		X
	575V-3ph - C1EH0900C-1J	54W15		X
ECONOMIZER				
Economizer				
Economizer - Downflow or Horizontal (Outdoor Air Hood furnished)	K1ECON20C-1	54W77	OX	OX
Economizer Controls				
Differential Enthalpy	Order 2 - C1SNSR64FF1	53W64	X	X
Single Enthalpy	C1SNSR64FF1	53W64	OX	OX
¹ Downflow Barometric Relief Dampers				
Barometric Relief Dampers with Field Installed Exhaust Hood	C1DAMP50C	54W78	OX	OX
Exhaust Hood for Factory Installed Downflow Barometric Relief Dampers	C1HOOD20C-1	85M26	X	X
Horizontal Barometric Relief Dampers				
Barometric Relief Dampers with Exhaust Hood	LAGEDH18/24	16K99	X	X

¹ When Downflow Barometric Relief Dampers are factory installed the Exhaust Hood (85M26) must be ordered separately for field installation.
When Downflow Barometric Relief Dampers are ordered for field installation the Exhaust Hood is furnished with the dampers.

NOTE - Catalog and model numbers shown are for ordering field installed accessories.
OX - Configure To Order (Factory Installed) or Field Installed
O = Configure To Order (Factory Installed)
X = Field Installed

OPTIONS / ACCESSORIES

Item Description	Model Number	Catalog Number	180	240
OUTDOOR AIR				
Outdoor Air Dampers				
Motorized Dampers with Outdoor Air Hood	K1DAMP20C-1	58W62	OX	OX
Manual Dampers With Outdoor Air Hood	C1DAMP10C-1	54W76	OX	OX
POWER EXHAUST				
Standard Static	208/230V - C1PWRE10C-1Y	54W70	X	X
	460V - C1PWRE10C-1G	54W71	X	X
	575V - C1PWRE10C-1J	54W72	X	X
ROOF CURBS - DOWNFLOW				
Clip Curb				
8 in. height	C1CURB40CD1	26W32	X	X
14 in. height	LARMF18/30S-14	33K44	X	X
18 in. height	LARMF18/30S-18	33K45	X	X
24 in. height	LARMF18/30S-24	33K46	X	X
Standard				
14 in. height	LARMF18/36-14	16K87	X	X
24 in. height	LARMF18/36-24	16K88	X	X
Adjustable Pitched Curb				
14 in. height	L1CURB55C	43W26	X	X
ROOF CURBS - HORIZONTAL (REQUIRES HORIZONTAL RETURN AIR PANEL KIT)				
Standard				
26 in. height - slab applications	LARMFH18/24-26	97J33	X	X
37 in. height - rooftop applications	LARMFH18/24-37	38K53	X	X
Insulation Kit For Standard Horizontal Curbs				
for LARMFH18/24-26	C1INSU11C-1-	73K32	X	X
for LARMFH18/24-37	C1INSU13C-1-	73K34	X	X
Horizontal Return Air Panel Kit				
Required for Horizontal Applications with Roof Curb	C1HRAP10C-1-	87M00	X	X
CEILING DIFFUSERS				
Step-Down - Order one	RTD11-185	29G06	X	
	RTD11-275-R	29G07		X
	RTD11-150/180S (Canada only)	13K63	X	
	RTD11-275S (Canada only)	13K64		X
Flush - Order one	FD11-185	29G10	X	
	FD11-275-R	29G11		X
	FD11-150/180S (Canada only)	13K58	X	
	FD11-275S (Canada only)	13K59		X
Transitions (Supply and Return) - Order one	LASRT18	19K01	X	
	LASRT21/24	19K02		X
	LASRT18S (Canada only)	33K48	X	
	LASRT21/24S (Canada only)	33K49		X

NOTE - Catalog and model numbers shown are for ordering field installed accessories.

OX - Configure To Order (Factory Installed) or Field Installed

O = Configure To Order (Factory Installed)

X = Field Installed

SPECIFICATIONS

General Data		Nominal Tonnage	15 Ton	20 Ton	
		Model Number	KHA180S4B	KHA240S4B	
		Efficiency Type	Standard	Standard	
		Blower Type	Constant Air Volume CAV	Constant Air Volume CAV	
Cooling Performance	Gross Cooling Capacity - Btuh		179,000	226,000	
	¹ Net Cooling Capacity - Btuh		174,000	218,000	
	AHRI Rated Air Flow - cfm		6000	7500	
	Total Unit Power - kW		16.4	20.5	
	¹ EER (Btuh/Watt)		10.6	10.6	
	² IEER (Btuh/Watt)		10.7	10.7	
	Refrigerant Type		R-410A	R-410A	
	Refrigerant Charge	Circuit 1	21 lbs. 0 oz.	26 lbs. 0 oz.	
	Furnished	Circuit 2	21 lbs. 0 oz.	26 lbs. 0 oz.	
Heating Performance	¹ Total High Heat Capacity - Btuh		178,000	220,000	
	Total Unit Power - kW		16.1	19.9	
	¹ C.O.P.		3.2	3.2	
	¹ Total Low Heat Capacity - Btuh		104,000	128,000	
	Total Unit Power (kW)		14.9	18.3	
	¹ C.O.P.		2.05	2.05	
Electric Heat Available - See page 3			15-30-45-60 kW	15-30-45-60-90 kW	
Compressor Type (number)			Scroll (2)	Scroll (2)	
Outdoor Coils	Net face area (total) - sq. ft.		57.0	57.0	
	Tube diameter - in.		3/8	3/8	
	Number of rows		1.66	2	
	Fins per inch		20	20	
Outdoor Coil Fans	Motor - (No.) horsepower		(4) 1/3	(4) 1/3	
	Motor rpm		1075	1075	
	Total Motor watts		1500	1500	
	Diameter - (No.) in.		(4) 24	(4) 24	
	Number of blades		3	3	
	Total Air volume - cfm		15,450	15,450	
Indoor Coils	Net face area (total) - sq. ft.		21.4	21.4	
	Tube diameter - in.		3/8	3/8	
	Number of rows		3	4	
	Fins per inch		14	14	
	Drain connection - No. and size		(1) 1 in. FPT	(1) 1 in. FPT	
	Expansion device type		Balance port TXV, removable head		
³ Indoor Blower and Drive Selection	Nominal motor output		3 hp, 5 hp, 7.5 hp	5 hp, 7.5 hp, 10 hp	
	Maximum usable motor output (US Only)		3.45 hp, 5.75 hp, 8.62 hp	5.75 hp, 8.62 hp, 11.5 hp	
	Motor - Drive kit number	3 hp		Kit 1 535-725 rpm	Kit 3 685-856 rpm
		5 hp		Kit 2 710-965 rpm	Kit 4 850-1045 rpm
		7.5 hp		Kit 3 685-856 rpm	Kit 5 945-1185 rpm
		5 hp		Kit 4 850-1045 rpm	Kit 6 850-1045 rpm
		7.5 hp		Kit 5 945-1185 rpm	Kit 7 945-1185 rpm
5 hp			Kit 6 850-1045 rpm	Kit 8 1045-1285 rpm	
7.5 hp			Kit 7 945-1185 rpm	Kit 7 945-1185 rpm	
5 hp			Kit 8 1045-1285 rpm	Kit 10 1045-1285 rpm	
Blower wheel nominal diameter x width - in.		(2) 15 x 15	(2) 15 x 15		
Filters	Type of filter		Fiberglass, disposable		
	Number and size - in.		(6) 24 x 24 x 2		
Electrical characteristics			208/230V, 460V or 575V - 60 hertz - 3 phase		

NOTE - Gross cooling capacity includes evaporator blower motor heat deduction. Net cooling capacity does not include evaporator blower motor heat deduction.

¹ Certified in accordance with the ULE certification program, which is based on AHRI Standard 340/360:

Cooling Ratings - 95°F outdoor air temperature and 80°F db/67°F wb entering indoor coil air.

High Temperature Heating Ratings - 47°F db/43°F wb outdoor air temperature and 70°F entering indoor coil air.

Low Temperature Heating Ratings - 17°F db/15°F wb outdoor air temperature and 70°F entering indoor coil air.

² Integrated Energy Efficiency Ratio certified and tested according to AHRI Standard 340/360.

³ Using total air volume and system static pressure requirements determine from blower performance tables rpm and motor output required. Maximum usable output of motors furnished are shown. In Canada, nominal motor output is also maximum usable motor output. If motors of comparable output are used, be sure to keep within the service factor limitations outlined on the motor nameplate.

BLOWER DATA

BLOWER TABLE INCLUDES RESISTANCE FOR BASE UNIT ONLY WITH DRY INDOOR COIL & AIR FILTERS IN PLACE
FOR ALL UNITS ADD:

- 1 - Wet indoor coil air resistance of selected unit.
- 2 - Any factory installed options air resistance (heat section, economizer, etc.)
- 3 - Any field installed accessories air resistance (duct resistance, diffuser, etc.)

Then determine from blower table blower motor output and drive required.

See page 7 for wet coil and option/accessory air resistance data.

See page 7 for factory installed drive kit specifications.

MINIMUM AIR VOLUME REQUIRED FOR USE WITH OPTIONAL ELECTRIC HEAT

All units require 6000 cfm minimum air with electric heat.

Air Volume cfm	TOTAL STATIC PRESSURE - In. w.g.																								
	0.40		0.60		0.80		1.00		1.20		1.40		1.60		1.80		2.00		2.20		2.40		2.60		
	RPM	BHP	RPM	BHP	RPM	BHP	RPM	BHP	RPM	BHP	RPM	BHP	RPM	BHP	RPM	BHP	RPM	BHP	RPM	BHP	RPM	BHP	RPM	BHP	RPM
4750	575	1.10	660	1.45	740	1.80	810	2.15	870	2.50	930	2.85	985	3.20	1040	3.55	1085	3.90	1135	4.25	1180	4.65	1225	5.00	
5000	585	1.25	670	1.60	750	1.95	815	2.30	880	2.70	940	3.05	995	3.40	1045	3.80	1095	4.15	1140	4.50	1185	4.90	1230	5.30	
5250	595	1.35	680	1.70	755	2.10	825	2.50	890	2.90	945	3.25	1000	3.65	1050	4.00	1100	4.40	1150	4.80	1195	5.20	1235	5.60	
5500	605	1.45	690	1.85	765	2.25	835	2.65	895	3.05	955	3.45	1010	3.85	1060	4.25	1110	4.70	1155	5.10	1200	5.50	1240	5.90	
5750	615	1.60	700	2.00	775	2.45	840	2.85	905	3.25	960	3.65	1015	4.10	1065	4.50	1115	4.95	1160	5.35	1205	5.80	1250	6.25	
6000	630	1.75	710	2.15	785	2.60	850	3.05	910	3.45	970	3.90	1025	4.35	1075	4.80	1120	5.20	1170	5.65	1215	6.10	1255	6.55	
6250	640	1.90	720	2.35	795	2.80	860	3.25	920	3.70	975	4.15	1030	4.60	1080	5.05	1130	5.50	1175	5.95	1220	6.45	1265	6.90	
6500	650	2.05	730	2.50	805	3.00	870	3.45	930	3.95	985	4.40	1040	4.85	1090	5.35	1140	5.85	1185	6.30	1225	6.75	1270	7.25	
6750	665	2.20	745	2.70	815	3.20	880	3.70	940	4.20	995	4.65	1045	5.10	1095	5.60	1145	6.10	1190	6.60	1235	7.10	1275	7.60	
7000	675	2.35	755	2.90	825	3.40	890	3.95	950	4.45	1005	4.95	1055	5.40	1105	5.95	1155	6.45	1200	6.95	1240	7.45	1285	8.00	
7250	690	2.60	765	3.10	835	3.65	900	4.15	955	4.65	1015	5.25	1065	5.75	1115	6.25	1160	6.75	1205	7.30	1250	7.85	1290	8.35	
7500	700	2.75	775	3.30	845	3.85	910	4.45	965	4.95	1020	5.50	1075	6.05	1125	6.60	1170	7.15	1215	7.65	1260	8.25	1300	8.75	
7750	715	3.00	790	3.55	855	4.10	920	4.70	975	5.25	1030	5.80	1080	6.35	1130	6.90	1180	7.50	1225	8.05	1265	8.60	1305	9.15	
8000	725	3.20	800	3.80	865	4.35	930	4.95	985	5.50	1040	6.10	1090	6.70	1140	7.25	1185	7.85	1230	8.40	1275	9.00	1315	9.60	
8250	740	3.40	810	4.00	880	4.65	940	5.25	995	5.85	1050	6.45	1100	7.05	1150	7.65	1195	8.25	1240	8.85	1280	9.40	1325	10.05	
8500	750	3.65	825	4.30	890	4.90	950	5.55	1005	6.15	1060	6.80	1110	7.40	1160	8.05	1205	8.65	1250	9.25	1290	9.85	1330	10.45	
8750	765	3.90	835	4.55	900	5.20	960	5.85	1015	6.45	1070	7.15	1120	7.75	1165	8.35	1215	9.05	1255	9.65	1300	10.30	1340	10.90	
9000	780	4.20	850	4.85	910	5.50	970	6.15	1025	6.80	1080	7.50	1130	8.15	1175	8.75	1220	9.40	1265	10.10	1310	10.80	1350	11.40	
9250	790	4.45	860	5.15	925	5.85	985	6.55	1040	7.20	1090	7.85	1140	8.55	1185	9.20	1230	9.85	1275	10.55	1315	11.20	---	---	
9500	805	4.75	875	5.45	935	6.15	995	6.90	1050	7.60	1100	8.25	1150	8.95	1195	9.60	1240	10.30	1285	11.05	---	---	---	---	
9750	820	5.05	885	5.75	950	6.55	1005	7.20	1060	7.95	1110	8.65	1160	9.40	1205	10.05	1250	10.80	1295	11.50	---	---	---	---	
10,000	835	5.40	900	6.15	960	6.85	1015	7.60	1070	8.35	1120	9.05	1170	9.80	1215	10.50	1260	11.25	---	---	---	---	---	---	
10,250	845	5.65	910	6.45	970	7.20	1030	8.00	1080	8.75	1135	9.55	1180	10.25	1225	11.00	---	---	---	---	---	---	---	---	
10,500	860	6.00	925	6.85	985	7.65	1040	8.40	1095	9.20	1145	10.00	1190	10.70	1235	11.45	---	---	---	---	---	---	---	---	
10,750	875	6.40	940	7.25	1000	8.05	1055	8.85	1105	9.65	1155	10.45	1200	11.20	---	---	---	---	---	---	---	---	---	---	
11,000	890	6.80	950	7.60	1010	8.45	1065	9.30	1115	10.05	1165	10.90	---	---	---	---	---	---	---	---	---	---	---	---	

BLOWER DATA

FACTORY INSTALLED BELT DRIVE KIT SPECIFICATIONS

Nominal hp	Maximum hp	Drive Kit Number	RPM Range
3	3.45	1	535 - 725
3	3.45	2	710 - 965
5	5.75	3	685 - 856
5	5.75	4	850 - 1045
5	5.75	5	945 - 1185
7.5	8.63	6	850 - 1045
7.5	8.63	7	945 - 1185
7.5	8.63	8	1045 - 1285
10	11.50	7	945 - 1185
10	11.50	10	1045 - 1285
10	11.50	11	1135 - 1365

NOTE - Using total air volume and system static pressure requirements determine from blower performance tables rpm and motor output required. Maximum usable output of motors furnished are shown. In Canada, nominal motor output is also maximum usable motor output. If motors of comparable output are used, be sure to keep within the service factor limitations outlined on the motor nameplate.

FACTORY INSTALLED OPTIONS/FIELD INSTALLED ACCESSORY AIR RESISTANCE - in. w.g.

Air Volume cfm	Wet Indoor Coil		Electric Heat	Economizer	Filters		Horizontal Roof Curb
	180S	240S			MERV 8	MERV 13	
4000	.02	.04	---	---	.04	.06	.06
4250	.02	.04	---	---	.04	.06	.07
4500	.02	.05	---	---	.04	.07	.07
4750	.02	.05	---	---	.04	.07	.08
5000	.03	.05	---	---	.05	.07	.08
5250	.03	.06	---	---	.05	.07	.09
5500	.03	.07	---	---	.05	.07	.10
5750	.03	.07	---	---	.05	.08	.11
6000	.04	.08	.01	---	.05	.08	.11
6250	.04	.08	.01	.01	.05	.08	.12
6500	.04	.09	.01	.02	.05	.08	.13
6750	.05	.10	.01	.03	.05	.08	.14
7000	.05	.10	.01	.04	.06	.08	.15
7250	.06	.11	.01	.05	.06	.09	.16
7500	.06	.12	.01	.06	.06	.09	.17
8000	.07	.13	.02	.09	.06	.09	.19
8500	.08	.15	.02	.11	.06	.09	.21
9000	.09	.16	.04	.14	.07	.10	.24
9500	.10	.18	.05	.16	.07	.10	.26
10,000	.11	.20	.06	.19	.07	.11	.29
10,500	.12	.22	.09	.22	.07	.11	.31
11,000	.14	.24	.11	.25	.08	.11	.34

BLOWER DATA

CEILING DIFFUSER AIR RESISTANCE - in. w.g.

Air Volume cfm	Step-Down Diffuser						Flush Diffuser	
	RTD11-185			RTD11-275			FD11-185	FD11-275
	2 Ends Open	1 Side/2 Ends Open	All Ends & Sides Open	2 Ends Open	1 Side/2 Ends Open	All Ends & Sides Open		
5000	.51	.44	.39	---	---	---	.27	---
5200	.56	.48	.42	---	---	---	.30	---
5400	.61	.52	.45	---	---	---	.33	---
5600	.66	.56	.48	---	---	---	.36	---
5800	.71	.59	.51	---	---	---	.39	---
6000	.76	.63	.55	.36	.31	.27	.42	.29
6200	.80	.68	.59	---	---	---	.46	---
6400	.86	.72	.63	---	---	---	.50	---
6500	---	---	---	.42	.36	.31	---	.34
6600	.92	.77	.67	---	---	---	.54	---
6800	.99	.83	.72	---	---	---	.58	---
7000	1.03	.87	.76	.49	.41	.36	.62	.40
7200	1.09	.92	.80	---	---	---	.66	---
7400	1.15	.97	.84	---	---	---	.70	---
7500	---	---	---	.51	.46	.41	---	.45
7600	1.20	1.02	.88	---	---	---	.74	---
8000	---	---	---	.59	.49	.43	---	.50
8500	---	---	---	.69	.58	.50	---	.57
9000	---	---	---	.79	.67	.58	---	.66
9500	---	---	---	.89	.75	.65	---	.74
10,000	---	---	---	1.00	.84	.73	---	.81
10,500	---	---	---	1.10	.92	.80	---	.89
11,000	---	---	---	1.21	1.01	.88	---	.96

CEILING DIFFUSER AIR THROW DATA

Model No.	Air Volume cfm	¹ Effective Throw Range - ft.		Model No.	Air Volume cfm	¹ Effective Throw Range - ft.	
		RTD11-185 Step-Down	FD11-185 Flush			RTD11-275 Step-Down	FD11-275 Flush
180	5600	39 - 49	28 - 37	240	7200	33 - 38	26 - 35
	5800	42 - 51	29 - 38		7400	35 - 40	28 - 37
	6000	44 - 54	40 - 50		7600	36 - 41	29 - 38
	6200	45 - 55	42 - 51		7800	38 - 43	40 - 50
	6400	46 - 55	43 - 52		8000	39 - 44	42 - 51
	6600	47 - 56	45 - 56		8200	41 - 46	43 - 52
					8400	43 - 49	44 - 54
					8600	44 - 50	46 - 57
					8800	47 - 55	48 - 59

¹ Throw is the horizontal or vertical distance an airstream travels on leaving the outletor diffuser before the maximum velocity is reduced to 50 ft. per minute. Four sides open.

POWER EXHAUST FAN PERFORMANCE

Return Air System Static Pressure	Air Volume Exhausted
in. w.g.	cfm
0.00	8630
0.05	8210
0.10	7725
0.15	7110
0.20	6470
0.25	5790
0.30	5060
0.35	4300
0.40	3510
0.45	2690
0.50	1840

ELECTRICAL/ELECTRIC HEAT DATA

15 TON

15 TON STANDARD EFFICIENCY

KHA180S4

¹ Voltage - 60hz		208/230V - 3 Ph			460V - 3 Ph			575V - 3 Ph		
Compressor 1	Rated Load Amps	25			12.2			9		
	Locked Rotor Amps	164			100			78		
Compressor 2	Rated Load Amps	25			12.2			9		
	Locked Rotor Amps	164			100			78		
Outdoor Fan Motors (3)	Full Load Amps (total)	2.4 (9.6)			1.3 (5.2)			1 (4)		
	Full Load Amps (total)	2.4 (4.8)			1.3 (2.6)			1 (2)		
Service Outlet 115V GFI (amps)		15			15			15		
Indoor Blower Motor	Horsepower	3	5	7.5	3	5	7.5	3	5	7.5
	Full Load Amps	10.6	16.7	24.2	4.8	7.6	11	3.9	6.1	9
² Maximum Overcurrent Protection	Unit Only	100	100	110	45	50	50	35	35	40
	With (2) 0.33 HP Power Exhaust	100	110	110	50	50	50	35	40	40
³ Minimum Circuit Ampacity	Unit Only	77	83	91	38	41	44	29	31	34
	With (2) 0.33 HP Power Exhaust	82	88	95	41	43	47	31	33	36

ELECTRIC HEAT DATA

Electric Heat Voltage		208V	240V	208V	240V	208V	240V	480V	480V	480V	600V	600V	600V	
² Maximum Overcurrent Protection	Unit+ Electric Heat	15 kW	125	125	125	150	150	150	70	70	70	50	50	60
	and (2) 0.33 HP Power Exhaust	30 kW	175	175	175	175	175	200	90	90	90	70	70	70
		45 kW	200	225	200	225	225	250	110	110	125	90	90	90
		60 kW	225	225	225	250	225	250	110	125	125	90	90	100
³ Minimum Circuit Ampacity	Unit+ Electric Heat	15 kW	116	122	122	128	130	136	61	63	67	47	49	52
	and (2) 0.33 HP Power Exhaust	30 kW	155	167	161	173	169	181	83	86	89	65	67	70
		45 kW	194	212	200	218	208	226	106	108	112	83	85	88
		60 kW	202	221	208	227	216	235	110	113	116	86	89	91
² Maximum Overcurrent Protection	Unit+ Electric Heat	15 kW	125	150	150	150	150	70	70	70	50	60	60	
	and (2) 0.33 HP Power Exhaust	30 kW	175	175	175	200	175	200	90	90	100	70	70	80
		45 kW	200	225	225	225	225	250	110	125	125	90	90	90
		60 kW	225	250	225	250	225	250	125	125	125	90	100	100
³ Minimum Circuit Ampacity	Unit+ Electric Heat	15 kW	121	127	127	133	134	140	63	66	69	49	51	54
	and (2) 0.33 HP Power Exhaust	30 kW	160	172	166	178	174	186	86	88	92	67	69	72
		45 kW	199	217	205	223	213	231	108	111	114	85	87	90
		60 kW	207	226	213	232	220	240	113	116	119	88	91	93

ELECTRICAL ACCESSORIES

Disconnect	Unit Only	54W86	54W86	54W86	54W86	54W86	54W86	54W86	54W85	54W85	54W85	54W85	54W85	54W85
	Unit + Power Exhaust	54W86	54W86	54W86	54W86	54W86	54W86	54W86	54W85	54W85	54W85	54W85	54W85	54W85
	Unit + Electric Heat 15 kW	54W86	54W86	54W86	54W86	54W86	54W86	54W86	54W85	54W85	54W85	54W85	54W85	54W85
	Unit + Electric Heat 30 kW	54W87	54W87	54W87	54W87	54W87	54W87	54W87	54W85	54W85	54W86	54W85	54W85	54W85
	Unit + Electric Heat 45 kW	54W87	54W87	54W87	54W87	54W87	54W87	54W87	54W86	54W86	54W86	54W85	54W85	54W86
	Unit + Electric Heat 60 kW	54W87	54W87	54W87	54W87	54W87	54W87	54W87	54W86	54W86	54W86	54W86	54W86	54W86
	Unit + Power Exhaust + Elec. Heat 15 kW	54W86	54W86	54W86	54W86	54W86	54W86	54W86	54W85	54W85	54W85	54W85	54W85	54W85
	Unit + Power Exhaust + Elec. Heat 30 kW	54W87	54W87	54W87	54W87	54W87	54W87	54W87	54W85	54W86	54W86	54W85	54W85	54W85
	Unit + Power Exhaust + Elec. Heat 45 kW	54W87	54W87	54W87	54W87	54W87	54W87	54W87	54W86	54W86	54W86	54W85	54W85	54W86
	Unit + Power Exhaust + Elec. Heat 60 kW	54W87	54W87	54W87	54W87	54W87	54W87	54W87	54W86	54W86	54W86	54W86	54W86	54W86

¹ Extremes of operating range are plus and minus 10% of line voltage.

² HACR type breaker or fuse.

³ Refer to National or Canadian Electrical Code manual to determine wire, fuse and disconnect size requirements.

⁴ Disconnect must be field furnished.

ELECTRICAL/ELECTRIC HEAT DATA

20 TON

20 TON STANDARD EFFICIENCY

KHA240S4

¹ Voltage - 60hz		208/230V - 3 Ph			460V - 3 Ph			575V - 3 Ph		
Compressor 1	Rated Load Amps	30.1			16.7			12.2		
	Locked Rotor Amps	225			114			80		
Compressor 2	Rated Load Amps	30.1			16.7			12.2		
	Locked Rotor Amps	225			114			80		
Outdoor Fan	Full Load Amps	2.4			1.3			1		
Motors (3)	(total)	(9.6)			(5.2)			(4)		
Power Exhaust	Full Load Amps	2.4			1.3			1		
(2) 0.33 HP	(total)	(4.8)			(2.6)			(2)		
Service Outlet 115V GFI (amps)		15			15			15		
Indoor Blower	Horsepower	5	7.5	10	5	7.5	10	5	7.5	10
Motor	Full Load Amps	16.7	24.2	30.8	7.6	11	14	6.1	9	11
² Maximum	Unit Only	110	125	125	60	70	70	45	50	50
Overcurrent	With (2) 0.33 HP	125	125	125	60	70	70	50	50	50
Protection	Power Exhaust									
³ Minimum	Unit Only	95	102	109	51	54	57	38	41	43
Circuit	With (2) 0.33 HP	99	107	114	53	57	60	40	43	45
Ampacity	Power Exhaust									

ELECTRIC HEAT DATA

Electric Heat Voltage		208V	240V	208V	240V	208V	240V	480V	480V	480V	600V	600V	600V	
² Maximum	Unit+ 15 kW	150	150	150	150	150	175	80	80	90	60	60	70	
Overcurrent	Electric Heat	30 kW	175	200	200	200	200	100	100	110	80	80	80	
		45 kW	225	250	225	250	250	250	125	125	125	100	100	100
		60 kW	225	250	250	250	250	300	125	150	150	100	110	110
		90 kW	300	350	300	350	300	350	175	175	175	125	150	150
³ Minimum	Unit+ 15 kW	134	140	141	147	148	154	73	77	80	56	59	61	
Circuit	Electric Heat	30 kW	173	185	180	192	187	199	96	99	102	74	77	79
		45 kW	212	230	219	237	226	244	119	122	125	92	95	97
		60 kW	220	239	227	246	234	253	123	126	129	96	99	101
		90 kW	282	311	290	319	296	325	159	163	166	125	128	130
² Maximum	Unit+ 15 kW	150	150	150	175	175	175	80	90	90	60	70	70	
Overcurrent	Electric Heat	30 kW	200	200	200	200	200	225	100	110	110	80	80	90
		45 kW	225	250	225	250	250	250	125	125	150	100	100	100
		60 kW	250	250	250	300	250	300	150	150	150	100	110	110
		90 kW	300	350	300	350	350	350	175	175	175	150	150	150
³ Minimum	Unit+ 15 kW	138	144	146	152	153	159	76	79	82	58	61	63	
Circuit	Electric Heat	30 kW	178	190	185	197	192	204	99	102	105	76	79	81
		45 kW	217	235	224	242	231	249	121	125	128	94	97	99
		60 kW	224	244	232	251	239	258	126	129	132	98	101	103
		90 kW	287	316	294	323	301	330	162	165	168	127	130	132
² Maximum	Unit+ 15 kW	150	150	150	175	175	175	80	90	90	60	70	70	
Overcurrent	Electric Heat	30 kW	200	200	200	200	200	225	100	110	110	80	80	90
		45 kW	225	250	225	250	250	250	125	125	150	100	100	100
		60 kW	250	250	250	300	250	300	150	150	150	100	110	110
		90 kW	300	350	300	350	350	350	175	175	175	150	150	150
³ Minimum	Unit+ 15 kW	138	144	146	152	153	159	76	79	82	58	61	63	
Circuit	Electric Heat	30 kW	178	190	185	197	192	204	99	102	105	76	79	81
		45 kW	217	235	224	242	231	249	121	125	128	94	97	99
		60 kW	224	244	232	251	239	258	126	129	132	98	101	103
		90 kW	287	316	294	323	301	330	162	165	168	127	130	132

ELECTRICAL ACCESSORIES

Disconnect	Unit Only	54W86	54W86	54W86	54W86	54W86	54W86	54W86	54W86	54W85	54W85	54W85	54W85	54W85	54W85
	Unit + Power Exhaust	54W86	54W86	54W86	54W86	54W86	54W86	54W86	54W86	54W85	54W85	54W85	54W85	54W85	54W85
	Unit + Electric Heat 15 kW	54W86	54W86	54W86	54W86	54W86	54W86	54W86	54W86	54W85	54W85	54W85	54W85	54W85	54W85
	Unit + Electric Heat 30 kW	54W87	54W87	54W87	54W87	54W87	54W87	54W87	54W87	54W86	54W86	54W86	54W85	54W85	54W85
	Unit + Electric Heat 45 kW	54W87	54W87	54W87	54W87	54W87	54W87	54W87	54W87	54W86	54W86	54W86	54W86	54W86	54W86
	Unit + Electric Heat 60 kW	⁴ N/A	⁴ N/A	⁴ N/A	⁴ N/A	⁴ N/A	⁴ N/A	⁴ N/A	⁴ N/A	54W86	54W86	54W86	54W86	54W86	54W86
	Unit + Electric Heat 90 kW	⁴ N/A	⁴ N/A	⁴ N/A	⁴ N/A	⁴ N/A	⁴ N/A	⁴ N/A	⁴ N/A	54W87	54W87	54W87	54W86	54W86	54W86
	Unit + Power Exhaust + Elec. Heat 15 kW	54W86	54W86	54W86	54W86	54W87	54W87	54W87	54W85	54W85	54W85	54W85	54W85	54W85	54W85
	Unit + Power Exhaust + Elec. Heat 30 kW	54W87	54W87	54W87	54W87	54W87	54W87	54W87	54W86	54W86	54W86	54W85	54W85	54W85	54W85
	Unit + Power Exhaust + Elec. Heat 45 kW	54W87	54W87	54W87	54W87	54W87	54W87	54W87	54W86	54W86	54W86	54W86	54W86	54W86	54W86
	Unit + Power Exhaust + Elec. Heat 60 kW	⁴ N/A	⁴ N/A	⁴ N/A	⁴ N/A	⁴ N/A	⁴ N/A	⁴ N/A	⁴ N/A	54W86	54W86	54W86	54W86	54W86	54W86
	Unit + Power Exhaust + Elec. Heat 90 kW	⁴ N/A	⁴ N/A	⁴ N/A	⁴ N/A	⁴ N/A	⁴ N/A	⁴ N/A	⁴ N/A	54W87	54W87	54W87	54W86	54W86	54W86

¹ Extremes of operating range are plus and minus 10% of line voltage.

² HACR type breaker or fuse.

³ Refer to National or Canadian Electrical Code manual to determine wire, fuse and disconnect size requirements.

⁴ Disconnect must be field furnished.

ELECTRIC HEAT CAPACITIES

Volts Input	15 kW			30 kW			45 kW			60 kW			90 kW		
	kW Input	Btuh Output	No. of Stages	kW Input	Btuh Output	No. of Stages	kW Input	Btuh Output	No. of Stages	kW Input	Btuh Output	No. of Stages	kW Input	Btuh Output	No. of Stages
208	11.3	38,600	1	22.5	76,800	1	33.8	115,300	2	45.0	153,600	2	67.6	230,700	2
220	12.6	43,000	1	25.2	86,000	1	37.8	129,000	2	50.4	172,000	2	75.6	258,000	2
230	13.8	47,100	1	27.5	93,900	1	41.3	141,000	2	55.1	188,000	2	82.7	282,200	2
240	15.0	51,200	1	30.0	102,400	1	45.0	153,600	2	60.0	204,800	2	90.0	307,100	2
440	12.6	43,000	1	25.2	86,000	1	37.8	129,000	2	50.4	172,000	2	75.6	258,000	2
460	13.8	47,100	1	27.5	93,900	1	41.3	141,000	2	55.1	188,000	2	82.7	282,200	2
480	15.0	51,200	1	30.0	102,400	1	45.0	153,600	2	60.0	204,800	2	90.0	307,100	2
550	12.6	43,000	1	25.2	86,000	1	37.8	129,000	2	50.4	172,000	2	75.6	258,000	2
575	13.8	47,100	1	27.5	93,900	1	41.3	141,000	2	55.1	188,000	2	82.7	282,200	2
600	15.0	51,200	1	30.0	102,400	1	45.0	153,600	2	60.0	204,800	2	90.0	307,100	2

KHA PARTS ARRANGEMENT

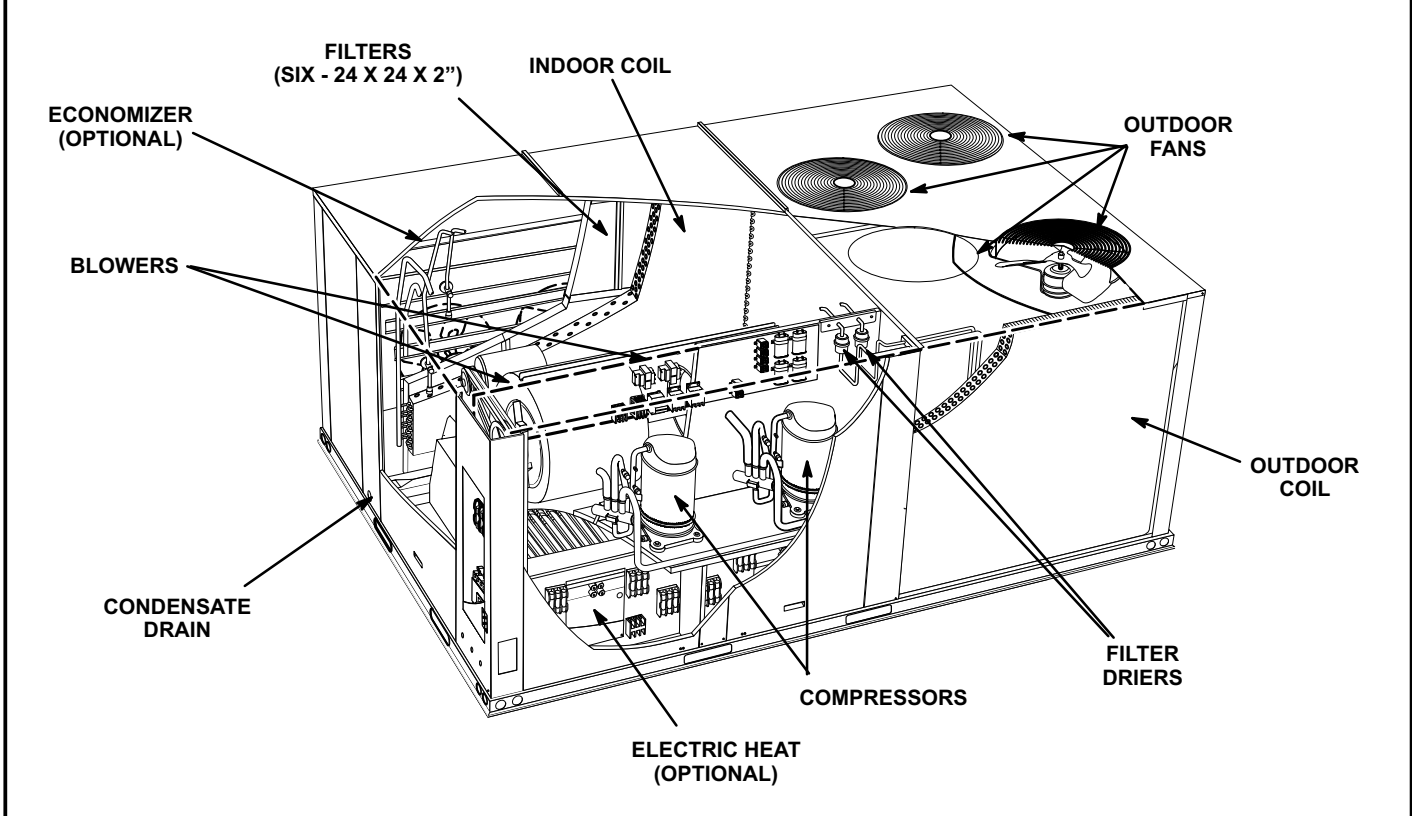

FIGURE 1

KHA CONTROL BOX

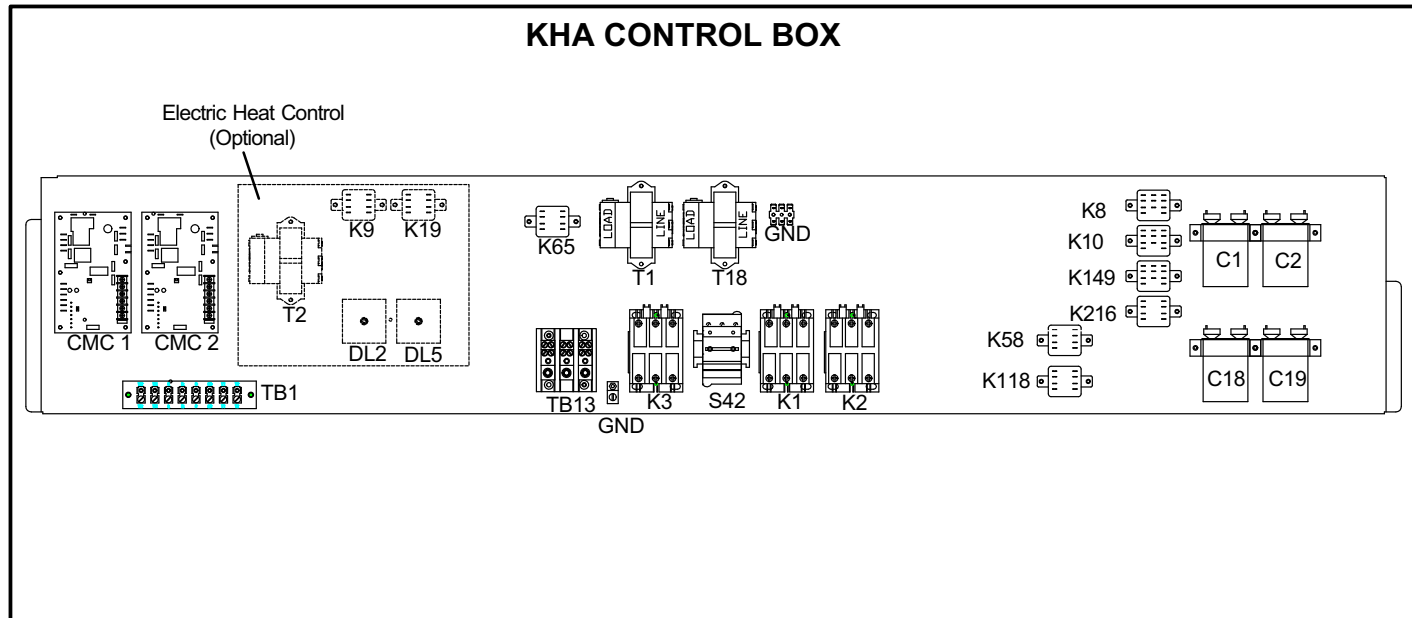

FIGURE 2

I-UNIT COMPONENTS

Unit components are shown in figure 1. All units come standard with removeable unit panels. All L1, L2 and L3 wiring is color coded; L1 is red, L2 is yellow and L3 is blue.

A-Control Box Components

Control box components are shown in figure 2. The control box is located in the compressor compartment.

1-Disconnect Switch S48 (field- or factory-installed)

All units may be equipped with an optional disconnect switch S48. S48 can be a toggle switch or a twist style switch. Both types can be used by the service technician to disconnect power to the unit.

2-Terminal Strip TB2

Units without S48 will have supply power connected to TB2.

3-Fuse F4

Fuse F4 is used only with single point power supply. F4 gives over amperage protection to the compressor and other cooling components. F4, S48 and TB2 are located inside a sheet metal enclosure in the unit left front corner mullion.

4-Terminal Strip TB13

All units are equipped with TB13. TB13 is located on the control panel in the compressor compartment.

5-Control Transformer T1

All units use a single line voltage to 24VAC transformer mounted in the control box. Transformer supplies power to control circuits in the unit. The transformer is rated at 70VA and is protected by a 3.5 amp circuit breaker (CB8) which is located on the transformer itself. The 208/230

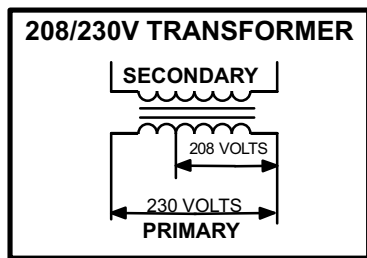

FIGURE 3

(Y) voltage transformers have two primary voltage taps, but only one may be used depending on supply voltage. See figure 3. 460 (G) and 575 (J) voltage transformers use a single primary voltage tap.

6-Control Transformer T18

T18 is a single line voltage to 24VAC transformer. Transformer T18 is protected by a 3.5 amp circuit breaker (CB18) located on the transformer itself. T18 is identical to transformer T1. The transformer supplies 24VAC power to the CMC1, CMC2 and reversing valves L1 and L2.

7-Terminal Strip TB1

All indoor thermostat connections will be to TB1 located on the control panel. For thermostats with “occupied “ and “un-occupied” modes, a factory installed jumper across terminals R and OC should be removed. Unit wiring is designed for a two-stage thermostat. See table 1.

TABLE 1

TB1 TERMINAL DESIGNATIONS	
Y1	Cool Stage 1
Y2	Cool Stage 2
W1	Heat Stage 1
W2	Heat Stage 2
OC	Occupied
G	Indoor Blower
R	24V To Thermostat
C	Ground

8-Outdoor Fan Capacitors C1, C2, C18 & C19

Fan capacitors C1, C2, C18, C19 are 10 MFD / 370V capacitors used to assist in the start up of condenser fans B4, B5, B21, B22 respectively.

9-Outdoor Fan Relay K10 & K149

Outdoor fan relays K10 and K149, are DPDT relays with a 24VAC coil. K10 energizes condenser fans B4 and B5 and K149 energizes condenser fans B21 and B22.

10-Compressor Contactor K1 & K2 (all units)

All compressor contactors are three-pole-double-break contactors with 24VAC coils. K1 and K2 energize compressors B1 and B2 respectively, in response to thermostat demand.

11-Blower Contactor K3

Blower contactor K3, used in all units, is a three-pole-double-break contactor with a 24VAC coil used to energize the indoor blower motor B3 in response to blower demand. K3 is energized from terminal G on TB1.

12-Blower Motor Overload Relay S42

S42 is a manual reset overload relay, used in all M voltage units and in units with a 10 HP blower motor. The relay is connected in line with the blower motor to monitor the current flow to the motor. When the relay senses an overload condition, a set of normally closed contacts opens de-energizing the 24 volt output of T1. See figure 4.

13-Power Exhaust Relay K65 (PED units)

Power exhaust relay K65 is a DPDT relay with a 24VAC coil. K65 is used in units equipped with field-installed, optional power exhaust dampers. K65 is energized by the economizer enthalpy control A6, after the economizer dampers reach 50% open (adjustable) When K65 closes, exhaust fans B10 and B11 are energized.

SIEMENS OVERLOAD RELAY

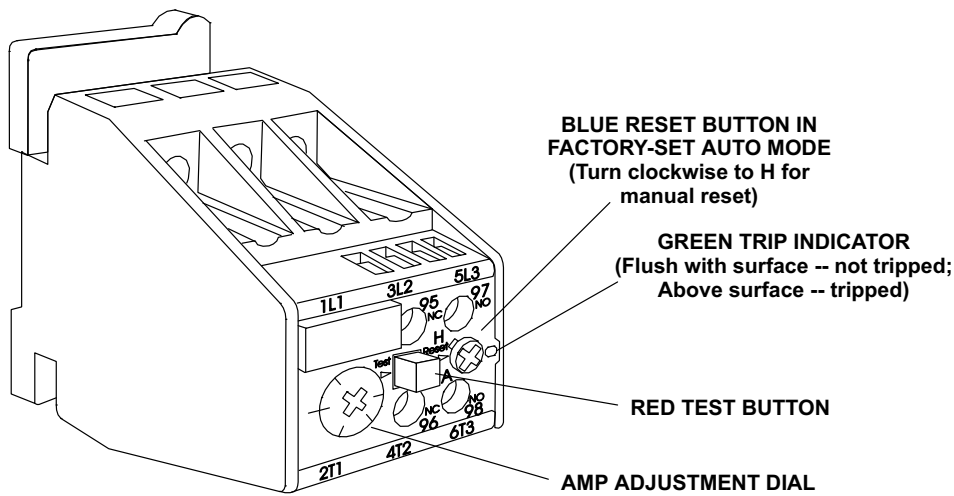

Adjust relay amp setting according to value given on the blower motor nameplate. Proper relay amp setting equals motor nameplate FLA X service factor of 1.15 X .95.
 Use small slotted screwdriver to adjust control mode from automatic reset (A) to manual reset (H). Control must be in the manual reset mode (H) to perform a test. Press the red test button. Green trip indicator should pop out. Press the blue reset screw to reset the relay.

FIGURE 4

14-Defrost Control Boards CMC1 & CMC2

The defrost thermostat, defrost pressure switch and the defrost control work together to ensure that the heat pump outdoor coil does not ice excessively during the heating mode.

Compressor Accumulated Run-Time Interval

The defrost control will not energize a defrost cycle unless the unit has been operating in heating mode for an accumulated 60 minutes (default). The run time interval can be changed by moving the jumper on the CMC board timing pins. See figure 5.

The defrost interval can be adjusted to 30, 60, or 90 minutes. The defrost timing jumper is factory-installed to provide a 60-minute defrost interval. If the timing selector jumper is not in place, the control defaults to a 90-minute defrost interval.

NOTE - When adjusting timing pins, set both CMC1 and CMC2 defrost controls to the same defrost interval.

Defrost Test Option

A TEST option is provided for troubleshooting. The TEST mode may be started any time the unit is in the heating mode and the defrost thermostat is closed or jumpered.

If the timing jumper is in the TEST position at power-up, the defrost control will ignore the test pins. When the jumper is placed across the TEST pins for two seconds, the control will enter the defrost mode. If the jumper is removed before an additional 5-second period has elapsed (7 seconds total), the unit will remain in defrost mode until the defrost pressure switch opens or 14 minutes have passed. If the

jumper is not removed until after the additional 5-second period has elapsed, the defrost will terminate and the test option will not function again until the jumper is removed and re-applied.

Diagnostic LEDs

The defrost board uses two LEDs for diagnostics. The LEDs flash a sequence according to the condition.

TABLE 2

Defrost Control Board Diagnostic LED		
Indicates	LED 1	LED 2
Normal operation / power to board	Synchronized Flash with LED 2	Synchronized Flash with LED 1
Board failure / no power	Off	Off
Board failure	On	On
Pressure switch open	Flash	On

DEFROST CONTROL BOARD CMC1 AND CMC2

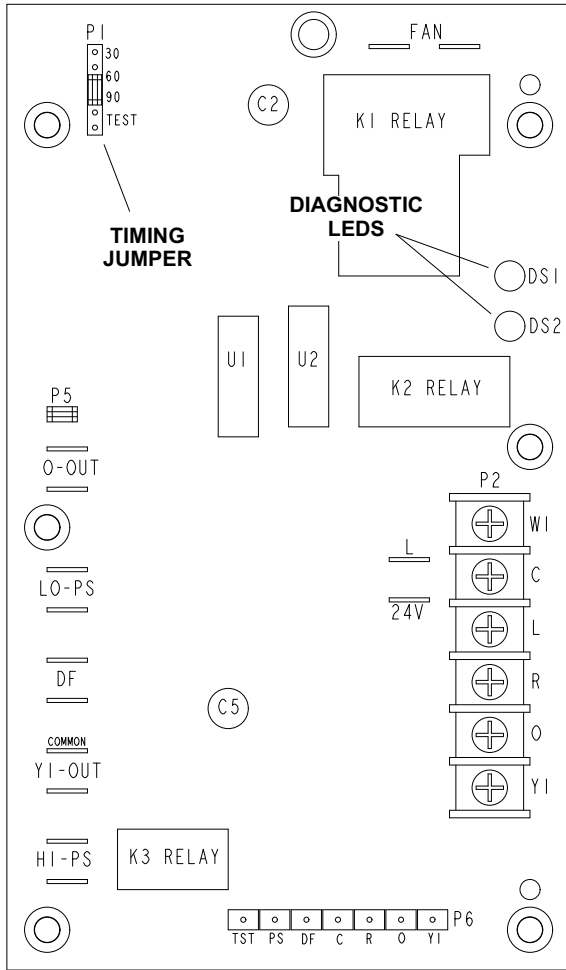

FIGURE 5

KHA180 PLUMBING, COMPRESSOR AND REFRIGERANT CIRCUITS DETAIL

FREEZESTATS (2)
FOR EACH STAGE
OF COIL (LOCATED
ON RETURN BEND)

SUCTION LINES
(DURING COOLING AND DEFROST),
DISCHARGE LINES (DURING HEATING)

LIQUID LINES

DEFROST
TEMPERATURE
SWITCHES
S6 (1ST STAGE)
AND
S9 (2ND STAGE)

DRIERS

DISCHARGE LINES (DURING
COOLING AND DEFROST),
SUCTION LINES (DURING HEATING)

COMPRESSOR DETAIL

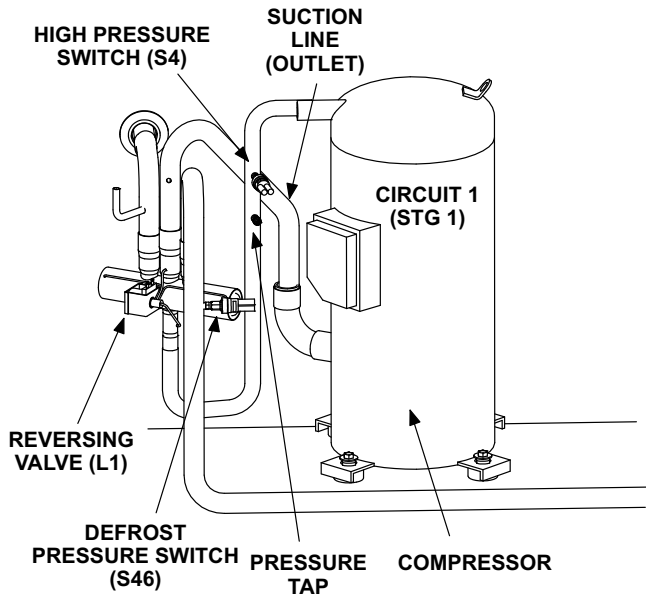

REFRIGERANT CIRCUITS

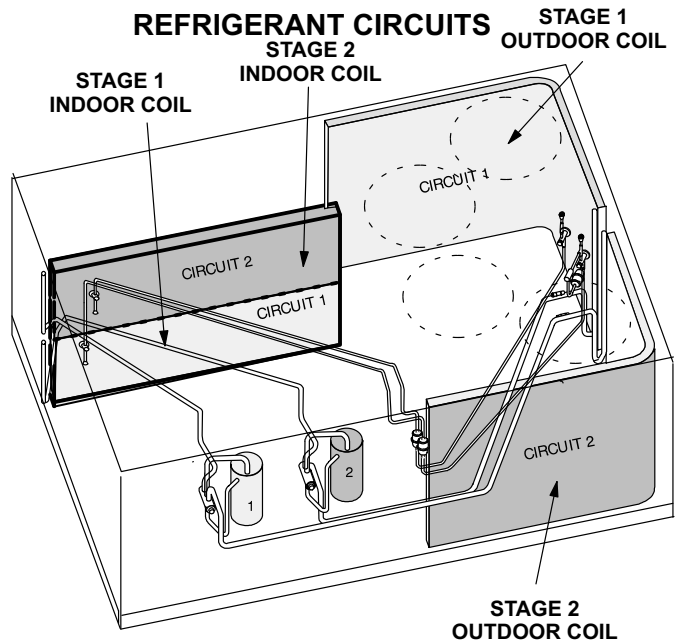

FIGURE 6

B-Cooling Components

All units use independent cooling circuits consisting of separate compressors, condenser coils and evaporator coils. See figures 6. Draw-through type condenser fans are used in all units. All units are equipped with belt-drive blowers which draw air across the evaporator during unit operation.

Cooling may be supplemented by an optional factory- or field-installed economizer. The evaporators are slab type and are stacked. Each evaporator uses a thermostatic expansion valve as the primary expansion device. Each evaporator is also equipped with enhanced fins and rifled tubing. In all units each compressor is protected by a freezestat (on each evaporator) and a high pressure switch (on each discharge line). Optional field installed low ambient switches are available for additional compressor protection.

1-Compressors B1, B2 (all units)

Both units are equipped with two scroll compressors. All units are equipped with independent cooling circuits. Compressor capacity may vary from stage to stage. In all cases, the capacity of each compressor is added to reach the total capacity of the unit. See "SPECIFICATIONS" and "ELECTRICAL DATA" (table of contents) or compressor nameplate for compressor specifications.

Each compressor is energized by a corresponding compressor contactor.

NOTE - Refer to the wiring diagram section for specific unit operation.

WARNING

Electrical shock hazard. Compressor must be grounded. Do not operate without protective cover over terminals. Disconnect power before removing protective cover. Discharge capacitors before servicing unit. Failure to follow these precautions could cause electrical shock resulting in injury or death.

2-Reversing Valves L1 and L2

A refrigerant reversing valve with a 24 volt solenoid coil is used to reverse refrigerant flow during unit operation. The reversing valve is connected in the vapor line of the refrigerant circuit. The reversing valve coil is energized during cooling demand and during defrost.

3-High Pressure Switches S4 and S7

The high pressure switch is an auto-reset SPST N.C switch which opens on a pressure rise. The switch is located in the compressor discharge line and is wired in series with the compressor contactor coil. Units are equipped with two switches.

S4 (first circuit) and S7 (second circuit) are wired in series with the respective compressor contactor coils.

When discharge pressure rises to 640 ± 10 psig (4413 ± 69 kPa) (indicating a problem in the system) the switch opens and the respective compressor is de-energized (the economizer can continue to operate). S4 and S7 will close once the pressure falls to 475 ± 20 psig (3275 ± 138 kPa)

4-Crankcase Heaters HR1 and HR2

Units use belly-band type crankcase heaters. HR1 is installed around compressor B1, heater HR2 compressor B2. Crankcase heater wattage varies by compressor size.

5-Low Ambient Switches S11 and S84 (optional accessory)

The low ambient switch is an auto-reset SPST N.O. pressure switch which allows for mechanical cooling operation at low outdoor temperatures. In all models a switch is located in each liquid line.

S11 is wired in series with outdoor fan relay K10, while S84 is wired in series with outdoor fan relay K149.

When liquid pressure rises to 450 ± 10 psig (3103 ± 69 kPa), the switch closes and the condenser fan is energized. When discharge pressure in both refrigerant circuits drop to 240 ± 10 psig (655 ± 69 kPa), the switch opens and the condenser fan is de-energized. This intermittent fan operation results in higher evaporating temperature allowing the system to operate without icing the evaporator coil and losing capacity.

6-Filter Drier (all units)

Units have a bi-flow filter drier located in the liquid line of each refrigerant circuit in the compressor compartment. The drier removes contaminants and moisture from the system.

7-Freezestats S49, S50

Each unit is equipped with a low temperature switch located on a return bend of each evaporator coil. S49 (first circuit) and S50 (second circuit) are located on the corresponding evaporator coils.

Each freezestat is wired in series with the corresponding compressor contactor. Each freezestat is an auto-reset switch which opens at $29^{\circ}\text{F} \pm 3^{\circ}\text{F}$ ($-1.7^{\circ}\text{C} \pm 1.7^{\circ}\text{C}$) on a temperature drop and closes at $58^{\circ}\text{F} \pm 4^{\circ}\text{F}$ ($14.4^{\circ}\text{C} \pm 2.2^{\circ}\text{C}$) on a temperature rise. To prevent coil icing, Freezestats open during compressor operation to temporarily disable the respective compressor until the coil temperature rises.

8-Condenser Fans B4, B5, B21 and B22 (all units)

See SPECIFICATIONS tables at the front of this manual for specifications of condenser fans. All condenser fans used have single-phase motors. The fan assembly may be removed for servicing and cleaning.

9-Defrost Components and Operation

a-Defrost Pressure Switch S46 and S104

The defrost pressure switches (S46 and S104) are auto-reset SPST N.C. pressure switches which open on a pressure rise. All units are equipped with these switches. The switches are located on the vapor line during heating cycle (discharge line during cooling and defrost cycle).

S46 (refrigeration circuit one) is wired to the main control board CMC1. S104 (refrigeration circuit two) is wired to the heat pump control board CMC2.

When discharge pressure reaches 450 ± 10 psig (3103 ± 69 kPa) (indicating defrost is completed) the switch opens. The switch automatically resets when pressure in the vapor line drops to 300 ± 10 psig (2068 ± 69 kPa).

b-Defrost Thermostat Switches S6 and S9 (all units)

Defrost thermostat switches S6 (refrigeration circuit one) and S9 (refrigeration circuit two) are S.P.S.T. N.O. contacts which close on a temperature fall (initiating defrost). The switches are located on each of the expansion valve distributor assemblies at the inlet to the outdoor coil. The switches monitor the outdoor coil suction temperature to determine when defrost is needed. When the outdoor coil suction temperature falls to $35^{\circ}\text{F} \pm 4^{\circ}\text{F}$ ($1.7^{\circ}\text{C} \pm 2.2^{\circ}\text{C}$) the switch closes (initiating defrost after minimum run time of 30, 60, or 90 minutes). When the temperature rises to $60^{\circ}\text{F} \pm 5^{\circ}\text{F}$ ($15.6^{\circ}\text{C} \pm 2.8^{\circ}\text{C}$) the switch opens.

DEFROST OPERATION

Defrost operation of each of the two refrigeration circuits are controlled independently with separate timers, thermostats (S6 and S9) and pressure switches (S46 and S104).

During heating operation when outdoor coil temperature drops to $35 \pm 4^{\circ}$, the defrost thermostat S6 or S9 closes initiating defrost.

When defrost begins, the reversing valve (L1 or L2) for the circuit in defrost mode is energized. Supplemental electric heat is then energized.

When L1 energizes, N.C. K58-1 contacts open de-energizing outdoor fan relay K10, followed by outdoor fan B4. When L2 energizes, N.C. K118-1 contacts open de-energizing outdoor fan relay K149, followed by outdoor fan B5.

Defrost of a circuit terminates when the pressure switch for the circuit (S46 or S104) opens or when 15 minutes elapse. Defrost does **not** terminate when thermostat demand ends.

C-Blower Compartment

The blower compartment is located between the evaporator coil and the compressor / control section on the opposite side of the condenser coil. The blower assembly is accessed by removing the screws on either side of the sliding base. The base pulls out as shown in figure 7.

1-Blower Wheels

Units have two 15 in. x 15 in. (381 mm x 381 mm) blower wheels. Both wheels are driven by one motor mounted on a single shaft. Shaft bearings are equipped with grease ports for service.

2-Indoor Blower Motor B3

All units use three-phase single-speed blower motors. CFM adjustments are made by adjusting the motor pulley (sheave). Motors are equipped with sealed ball bearings. All motor specifications are listed in the SPECIFICATIONS (table of contents) in the front of this manual. Units may be equipped with motors manufactured by various manufacturers, therefore electrical FLA and LRA specifications will vary. See unit rating plate for information specific to your unit.

OPERATION / ADJUSTMENT

Blower Operation

Initiate blower demand at thermostat according to instructions provided with thermostat. Unit will cycle on thermostat demand. The following steps apply to applications using a typical elector-mechanical thermostat.

- 1- Blower operation is manually set at the thermostat sub-base fan switch. With fan switch in **ON** position, blowers will operate continuously.
- 2- With fan switch in **AUTO** position, the blowers will cycle with demand. Blowers and entire unit will be off when system switch is in **OFF** position.

Blower Access

The blower assembly is secured to a sliding base which allows the entire assembly to be pulled out of the unit. See figure 7.

- 1- Remove the clamp which secures the blower wiring to the blower motor base.
- 2- Remove and retain screws on either side of sliding base. Pull base toward outside of unit. When pulling the base out further than 12" (305mm), disconnect wiring to K3 blower contactor T1, T2 and T3. Pull wiring toward blower to allow enough slack to slide the base out further.

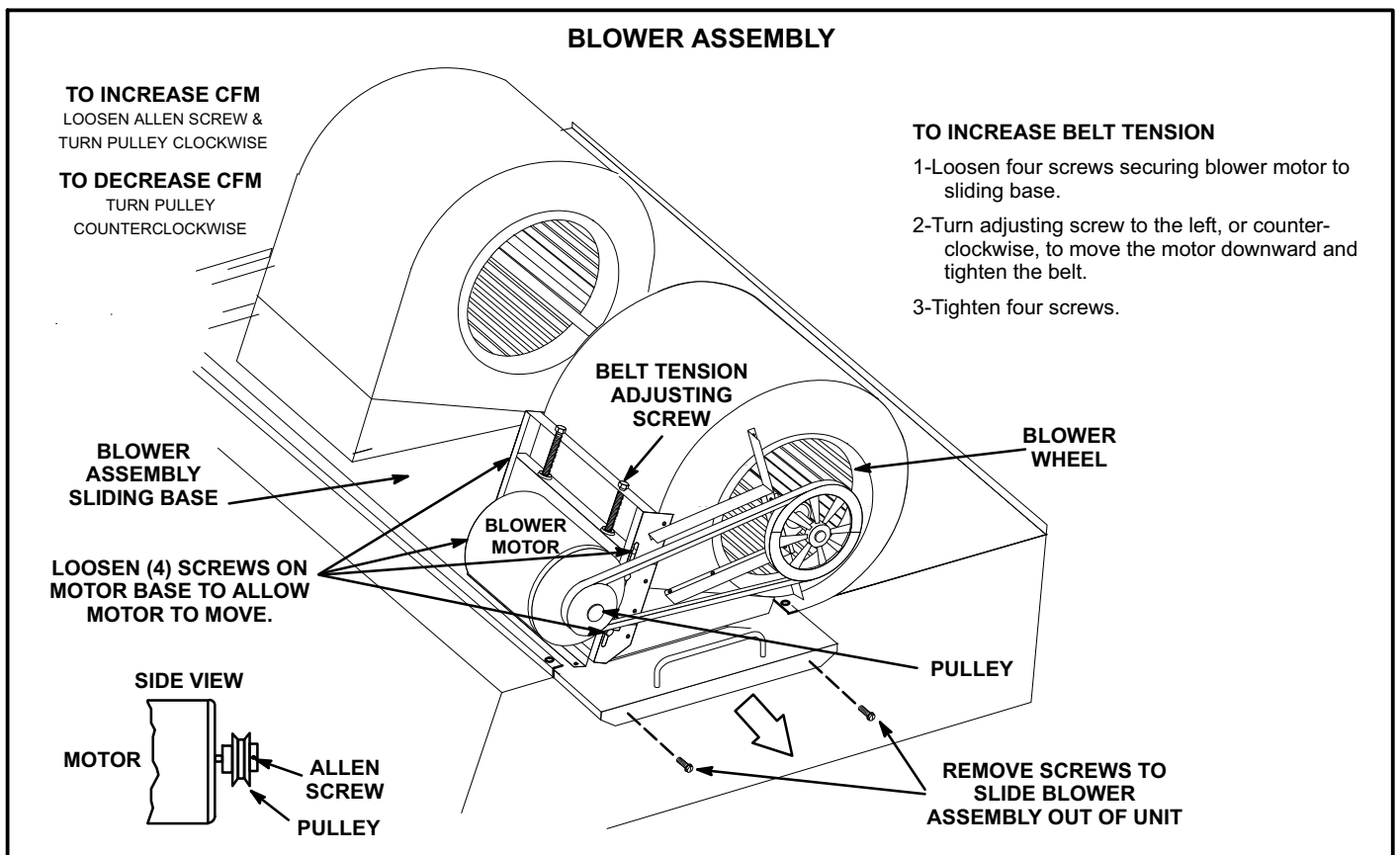

FIGURE 7

- 3- Slide base back into original position when finished servicing. Replace the clamp and blower wiring in the previous location on the blower motor base. Reconnect wiring to K3 if it was disconnected.
- 4- Replace retained screws on either side of the sliding base.

Determining Unit Air Volume

- 1- The following measurements must be made with a dry indoor coil. Run blower without cooling demand. Air filters must be in place when measurements are taken.
- 2- With all access panels in place, measure static pressure external to unit (from supply to return).
- 3- Measure the indoor blower wheel RPM.
- 4- Refer to blower tables in BLOWER DATA (table of contents) in the front of this manual. Use static pressure and RPM readings to determine unit air volume.
- 5- The RPM can be adjusted at the motor pulley. Loosen Allen screw and turn adjustable pulley clockwise to increase RPM. Turn counterclockwise to decrease RPM. See figure 7. Tighten Allen screw after adjustment.

Blower Belt Adjustment

Maximum life and wear can be obtained from belts only if proper pulley alignment and belt tension are maintained. Tension new belts after a 24-48 hour period of operation. This will allow belt to stretch and seat grooves. Make sure blower and motor pulley are aligned as shown in figure 8.

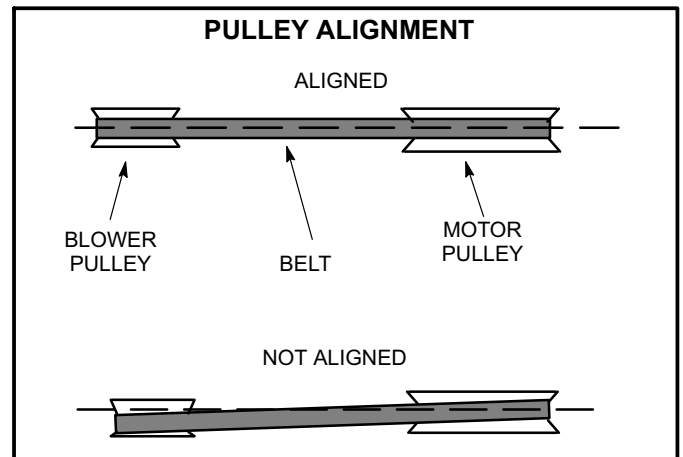

FIGURE 8

- 1- Loosen four bolts securing motor base to mounting frame. See figure 7.
- 2- *To relieve belt tension -*
 Turn adjusting bolt to the right, or clockwise, to move the motor upward and loosen the belt. This decreases the distance between the blower motor pulley and the blower housing pulley.
To increase belt tension -
 Turn the adjusting bolt to the left, or counterclockwise to increase belt tension. This increases the distance between motor pulley and blower housing pulley (motor moves downward and tightens belt).
- 3- Tighten four bolts securing motor base to mounting frame.

IMPORTANT - Align top edges of blower motor base and mounting frame base parallel before tightening bolts on the both sides of base. Motor shaft and blower shaft must be parallel.

Check Belt Tension

Overtensioning belts shortens belt and bearing life. Check belt tension as follows:

- 1- Measure span length X. See figure 9.
- 2- Apply perpendicular force to center of span (X) with enough pressure to deflect belt 1/64" for every inch of span length or 1.5mm per 100mm of span length.
 Example: Deflection distance of a 40" span would be 40/64" or 5/8".
 Example: Deflection distance of a 400mm span would be 6mm.
- 3- Measure belt deflection force. For a used belt, the deflection force should be 5 lbs. (35kPa). A new belt deflection force should be 7 lbs. (48kPa).

A force below these values indicates an undertensioned belt. A force above these values indicates an overtensioned belt.

Field-Furnished Blower Drives

Reference blower tables in BLOWER DATA (table of contents) in the front of this manual to determine the drive number and table 3 to determine the manufacturer's model number.

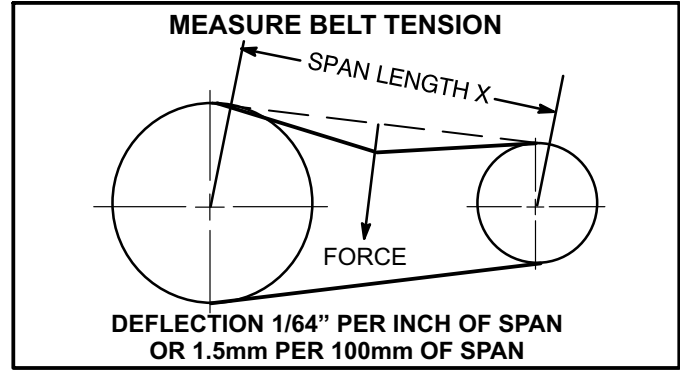

FIGURE 9

**TABLE 3
MANUFACTURER'S NUMBERS**

Drive No.	H.P.	DRIVE COMPONENTS									
		RPM		ADJUSTABLE SHEAVE		FIXED SHEAVE		BELTS		SPLIT BUSHING	
		Min	Max	Supplier No.	OEM Part No.	Supplier No.	OEM Part No.	Supplier No.	OEM Part No.	Supplier No.	OEM Part No.
1	3	535	725	1VP40x7/8	79J0301	BK95X1-7/16	80K1601	BX59	59A5001	N/A	N/A
2	3	710	965	1VP40x7/8	79J0301	BK72x1-7/16	100244-13	BX55	63K0501	N/A	N/A
3	5	685	865	1VP50x1-1/8	P-8-1977	BK100x1-7/16	39L1301	BX61	93J9801	N/A	N/A
4	5	850	1045	1VP65x1-1/8	100239-03	BK110H	100788-06	BX65	100245-08	H-1-7/16	49M6201
5	5	945	1185	1VP60x1-1/8	41C1301	BK90H	100788-04	BX61	93J9801	H-1-7/16	49M6201
6	7.5	850	1045	1VP65x1-3/8	78M7101	BK110H	100788-06	BX66	97J5901	H-1-7/16	49M6201
7	7.5, 10	945	1185	1VP60x1-3/8	78L5501	BK90H	100788-04	BX63	97J5501	H-1-7/16	49M6201
8	7.5	1045	1285	1VP65x1-3/8	78M7101	BK90H	100788-04	BX64	97J5801	H-1-7/16	49M6201
10	10	1045	1285	1VP65x1-3/8	78M7101	1B5V86	78M8301	5VX670	100245-21	B-1-7/16	100246-01
11	10	1135	1365	1VP65x1-3/8	78M7101	1B5V80	100240-05	5VX660	100245-20	B-1-7/16	100246-01

D-Optional Electric Heat Components

See ELECTRICAL / ELECTRIC HEAT (table of contents) for possible KHA to C1EH match-ups and electrical ratings. All electric heat sections consist of electric heating elements exposed directly to the air stream. See figure 1. Two electric heat sections (first section and second section) are used in all 15kW through 90kW heaters. Multiple-stage elements are sequenced on and off in response to thermostat demand. C1EH parts arrangement is shown in figures 11 and 12.

Control Box Components

The main control box (see figure 2) houses some electric heat components and the electric heat control "hat" section (figure 10).

Electric Heat Hat Section (Figure 10)

1-Electric Heat Relay K9

All units equipped with electric heat use an electric heat relay K9. K9 is a N.O. DPDT pilot relay intended to electrically isolate the unit's 24V circuit from the electric heat assembly 24V circuit. K9 is energized by W1 TB1. K9-1 closes, enabling T2 to energize the electric heat.

2-Electric Heat Relay K19

All units equipped with electric heat use an electric heat relay K19. K19 is a N.O. SPDT pilot relay intended to electrically isolate the unit's 24V circuit from the electric heat assembly 24V circuit. K19 is energized by TB1 (once K9 is energized). K19-1 closes, enabling T2 to energize the remaining electric heat.

3-Time Delay DL2

DL2 is a solid state timer used in all electric heat units. DL2 staggers the energizing of the first (W1) and second (W2) stage heating elements by providing a timed interval. When the timer is de-energizing, the contacts are delayed 1 second before opening.

4-Time Delay DL5

Time delay DL5 is identical to DL2. DL5 further staggers the (W2) second stage heating elements by providing a timed interval between the energizing of the elements activated by DL2 and elements activated by DL5.

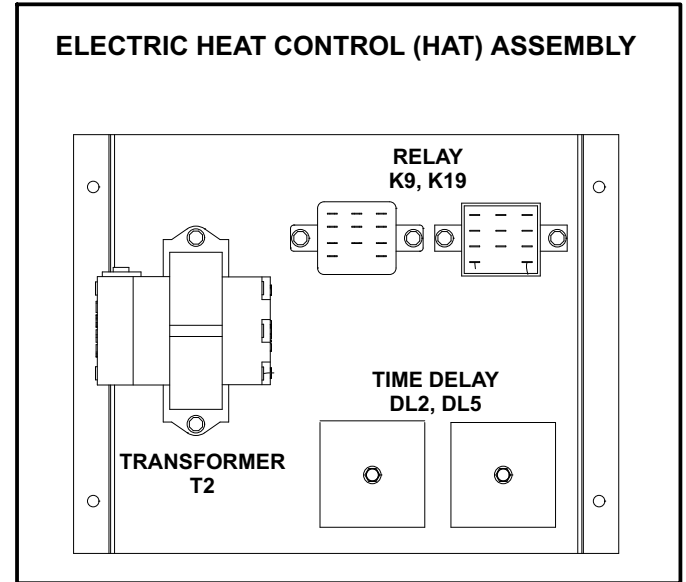

FIGURE 10

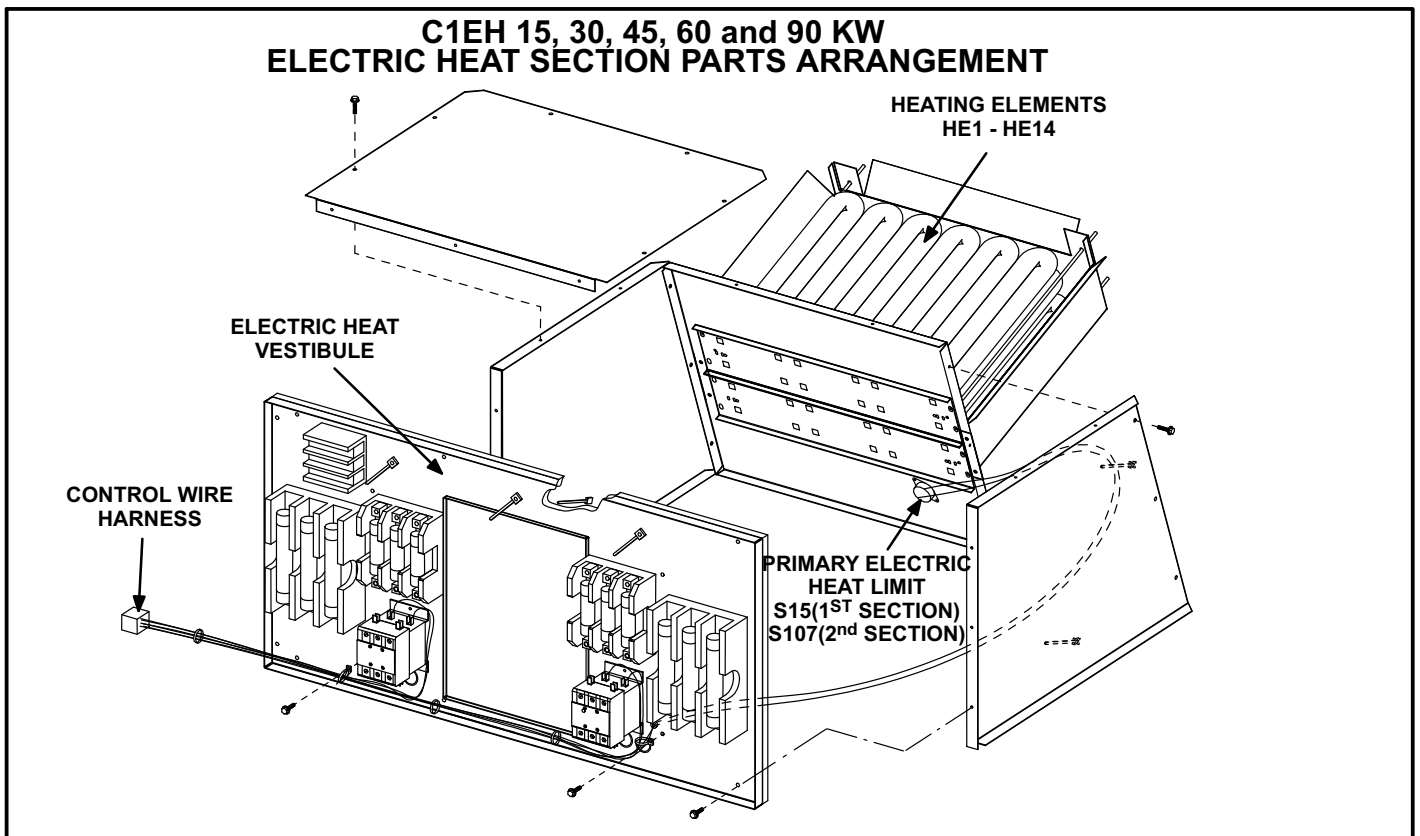

FIGURE 11

ELECTRIC HEAT VESTIBULE PARTS ARRANGEMENT

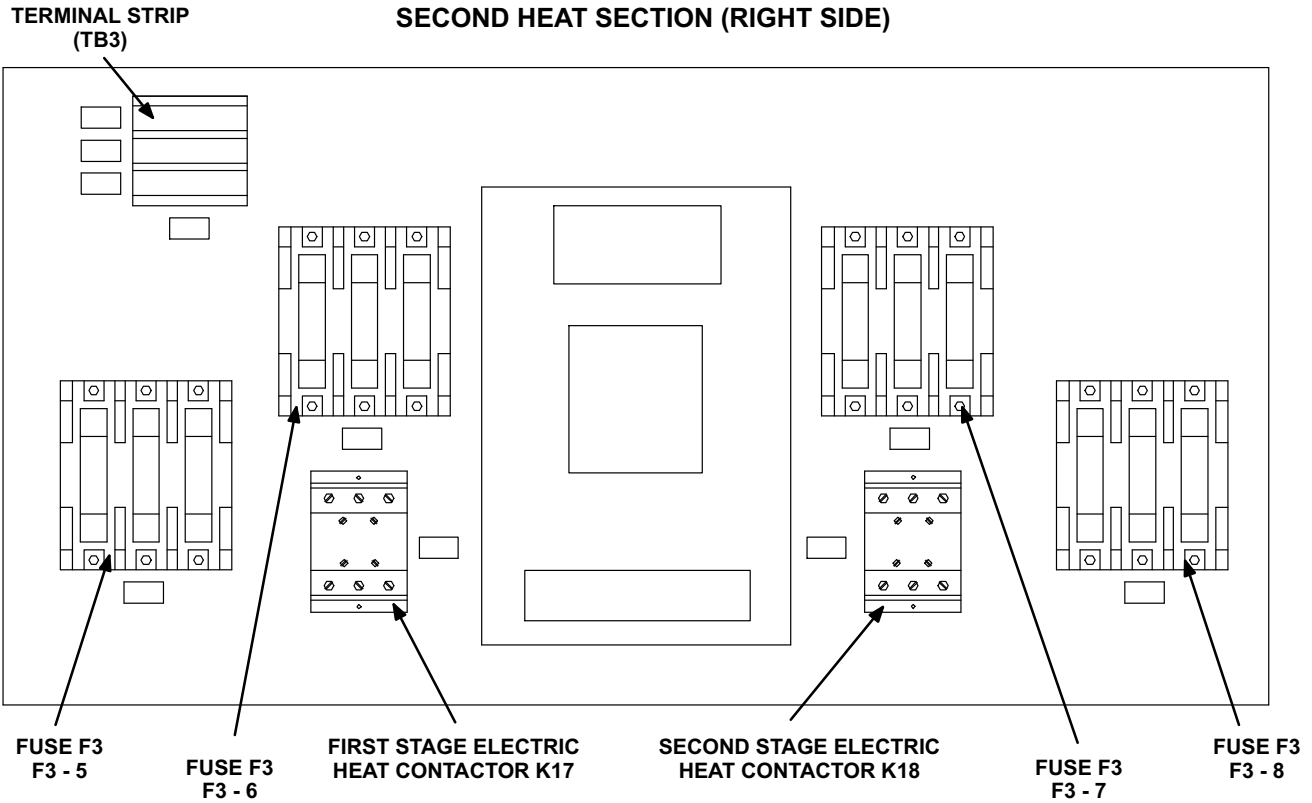
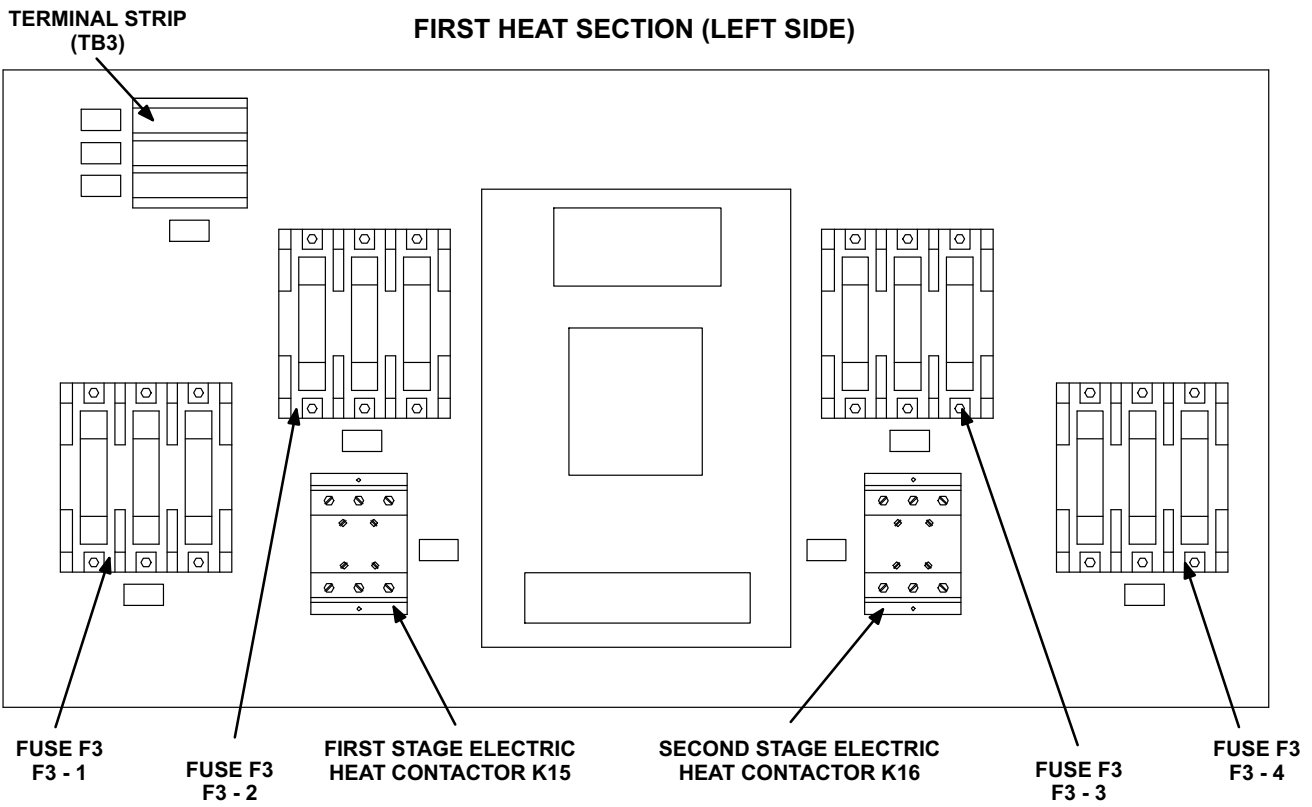

Figure 12

5-Electric Heat Transformer T2

All units equipped with electric heat use a single line voltage to 24VAC transformer mounted in the electric heat control hat section in the control box. The transformer supplies power to all electric heat controls (contactors and coils). The transformer is rated at 70VA and is protected by a 3.5 amp circuit breaker CB13 located on the body of T2. The 208/230 (Y) voltage transformers use two primary voltage taps as shown in figure 3. Transformer T2 is identical to T1.

Electric Heat Sections

6-Contactors K15, K16, K17 and K18

Contactors K15, K16, K17 and K18 are all three-pole double-break contactors located on the electric heat vestibule. K15 and K16 are located on the first electric heat section, while K17 and K18 are located on the second electric heat section. However, in the 15 and 30kW heaters, the first section houses all contactors and fuses. All contactors are equipped with a 24VAC coil. The coils in the K15, K16, K17 and K18 contactors are energized by the main panel A45. Contactors K15 and K17 energize the first stage heating elements, while K16 and K18 energize the second stage heating elements.

7-Fuse F3

Fuse F3 are housed in a fuse block which holds three fuses. Each F3 fuse is connected in series with each leg of electric heat. Figure 12 and table 4 show the fuses used with each electric heat section. For simplicity, the service manual labels the fuses F3 - 1 through F3 - 8.

8-Terminal Strip TB3

Electric heat line voltage connections are made to terminal

strip TB3 (or a fuse block on some models) located in the upper left corner of the electric heat vestibule.

9-High Temperature Limits S15 and S107 (Primary)

S15 and S107 are SPST N.C. auto-reset thermostats located on the back panel of the electric heat section below the heating elements. S15 is the high temperature limit for the first electric heat section, while S107 is the high temperature limit for the second electric heat section. Both thermostats are identical and are wired in series with the first stage contactor coil. When either S15 or S107 opens, indicating a problem in the system, contactor K15 is de-energized. When K15 is de-energized, first stage and all subsequent stages of heat are de-energized. The thermostats used on C1EH360-45-1 Y/G/J are factory set to open at $200^{\circ}\text{F} \pm 5^{\circ}\text{F}$ ($93.3^{\circ}\text{C} \pm 2.8^{\circ}\text{C}$) on a temperature rise and automatically reset at $160^{\circ}\text{F} \pm 6^{\circ}\text{F}$ ($71.1^{\circ}\text{C} \pm 3.3^{\circ}\text{C}$) on a temperature fall. All other electric heat section thermostats are factory set to open at $170^{\circ}\text{F} \pm 5^{\circ}\text{F}$ ($76.7^{\circ}\text{C} \pm 2.8^{\circ}\text{C}$) on a temperature rise and automatically reset at $130^{\circ}\text{F} \pm 6^{\circ}\text{F}$ ($54.4^{\circ}\text{C} \pm 3.3^{\circ}\text{C}$) on a temperature fall. The thermostats are not adjustable.

10-Heating Elements HE1 through HE14

Heating elements are composed of helix wound bare nichrome wire exposed directly to the air stream. Three elements are connected in a three-phase arrangement. The elements in 208/230V units are connected in a "Delta" arrangement. Elements in 460 and 575V units are connected in "Wye" arrangement. Each stage is energized independently by the corresponding contactors located on the electric heat vestibule panel. Once energized, heat transfer is instantaneous. High temperature protection is provided by primary and redundant high temperature limits and over-current protection is provided by fuses.

TABLE 4

KHA180/240 ELECTRIC HEAT SECTION FUSE RATING									
C1EH QUANTITY & SIZE	VOLTAGES	FUSE (3 each)							
		F3 - 1	F3 - 2	F3 - 3	F3 - 4	F3 - 5	F3 - 6	F3 - 7	F3 - 8
(1) 240-7.5 & (1) 240S-7.5 (15 kW Total)	208/230V	50 Amp 250V	---	---	---	---	---	---	---
	460V	25 Amp 600V	---	---	---	---	---	---	---
	575V	20 Amp 600V	---	---	---	---	---	---	---
(1) 360-15 & (1) 360S-15 (30 kW Total) or (1) 156-15 & (1) 156S-15	208/230V	60 Amp 250V	60 Amp 250V	---	---	---	---	---	---
	460V	50 Amp 600V	---	---	---	---	---	---	---
	575V	40 Amp 600V	---	---	---	---	---	---	---
(2) 360-22.5 (45 kW Total) or (2) 156-22.5	208/230V	50 Amp 250V	---	---	25 Amp 250V	50 Amp 250V	---	---	25 Amp 250V
	460V	25 Amp 600V	---	---	15 Amp 600V	25 Amp 600V	---	---	15 Amp 600V
	575V	20 Amp 600V	---	---	10 Amp 600V	20 Amp 600V	---	---	10 Amp 600V
(2) 150-30 (60 kW Total) or (2) 156-30	208/230V	50 Amp 250V	---	---	50 Amp 250V	50 Amp 250V	---	---	50 Amp 250V
	460V	25 Amp 600V	---	---	25 Amp 600V	25 Amp 600V	---	---	25 Amp 600V
	575V	20 Amp 600V	---	---	20 Amp 600V	20 Amp 600V	---	---	20 Amp 600V
(2) 360-45 (90 kW Total)	208/230V	50 Amp 250V	---	60 Amp 250V	60 Amp 250V	50 Amp 250V	---	60 Amp 250V	60 Amp 250V
	460V	25 Amp 600V	---	---	50 Amp 600V	25 Amp 600V	---	---	50 Amp 600V
	575V	20 Amp 600V	---	---	40 Amp 600V	20 Amp 600V	---	---	40 Amp 600V

II-PLACEMENT AND INSTALLATION

Make sure the unit is installed in accordance with the installation instructions and all applicable codes. See accessories section for conditions requiring use of the optional roof mounting frame.

III-STARTUP - OPERATION

Refer to startup directions and to the unit wiring diagram when servicing. See unit nameplate for minimum circuit ampacity and maximum fuse size.

A-Preliminary and Seasonal Checks

- 1- Make sure the unit is installed in accordance with the installation instructions and applicable codes.
- 2- Inspect all electrical wiring, both field and factory installed for loose connections. Tighten as required. Refer to unit diagram located on inside of unit control box cover.
- 3- Check to ensure that refrigerant lines are in good condition and do not rub against the cabinet or other refrigerant lines.
- 4- Check voltage at the disconnect switch (if applicable) or TB2. Voltage must be within the range listed on the nameplate. If not, consult the power company and have the voltage corrected before starting the unit.
- 5- Recheck voltage and amp draw with unit running. If voltage is not within range listed on unit nameplate, stop unit and consult power company. Refer to unit nameplate for maximum rated load amps.
- 6- Inspect and adjust blower belt (see section on Blower Compartment - Blower Belt Adjustment).

B-Cooling Start Up

- 1- Remove coil covers before starting unit.
- 2- Initiate first and second stage cooling demands according to instructions provided with thermostat.
A first-stage (Y1) cooling demand will energize compressor 1 and outdoor fans 1 & 2. An increased cooling demand (Y2) will initiate compressor 2 and outdoor fans 3 & 4. On units with an economizer, when outdoor air is acceptable, a first-stage demand will energize the economizer; a second-stage demand will energize compressor 1 and outdoor fans 1 & 2.
- 3- Refrigerant circuits are factory charged with R-410A refrigerant. See unit rating plate for correct amount of charge.
- 4- Units contain two refrigerant circuits or systems. See figure 13.

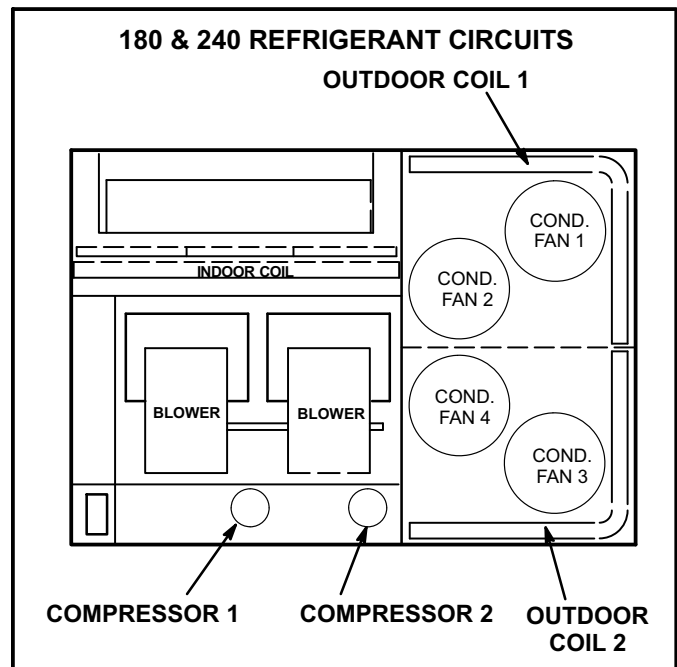

FIGURE 13

IV-CHARGING

WARNING

Refrigerant can be harmful if it is inhaled. Refrigerant must be used and recovered responsibly.

Failure to follow this warning may result in personal injury or death.

WARNING - Do not exceed nameplate charge under any condition.

This unit is factory-charged and should require no further adjustment. If the system requires additional refrigerant, reclaim the charge, evacuate the system and add required nameplate charge.

NOTE - System charging is not recommended below 60°F (15°C). In temperatures below 60°F (15°C), the charge must be weighed into the system.

If weighing facilities are not available, or to check the charge, use the following procedure:

- 1- Attach gauge manifolds and operate unit in cooling mode with economizer disabled until system stabilizes (approximately five minutes). Make sure outdoor air dampers are closed.
- 2- Check each system separately with all stages operating.
- 3- Use a thermometer to accurately measure the outdoor ambient temperature.
- 4- Apply the outdoor temperature to tables 5 through 6 to determine normal operating pressures. Pressures are listed for sea level applications at 80°F dry bulb and 67°F wet bulb return air.
- 5- Compare the normal operating pressures to the pressures obtained from the gauges. Minor variations in these pressures may be expected due to differences in installations. Significant differences could mean that the system is not properly charged or that a problem exists with some component in the system. **Correct any system problems before proceeding.**
- 6- If discharge pressure is high, remove refrigerant from the system. If discharge pressure is low, add refrigerant to the system.
 - Add or remove charge in increments.
 - Allow the system to stabilize each time refrigerant is added or removed.
- 7- Use the following approach method along with the normal operating pressures to confirm readings.

**TABLE 5
KHA180 NORMAL OPERATING PRESSURES**

Outdoor Coil Entering Air Temp	Circuit 1		Circuit 2	
	Dis. ± 10 psig	Suc. ± 5 psig	Dis. ± 10 psig	Suc. ± 5 psig
65°F	270	138	270	135
75°F	312	139	312	135
85°F	356	142	356	136
95°F	403	144	404	138
105°F	455	147	458	140
115°F	512	147	515	145

**TABLE 6
KHA240 NORMAL OPERATING PRESSURES**

Outdoor Coil Entering Air Temp	Circuit 1		Circuit 2	
	Dis. ± 10 psig	Suc. ± 5 psig	Dis. ± 10 psig	Suc. ± 5 psig
65°F	275	135	278	135
75°F	315	138	318	136
85°F	359	140	364	138
95°F	407	142	413	140
105°F	457	144	466	141
115°F	517	146	527	145

C-Charge Verification - Approach Method - AHRI Testing

- 1- Using the same thermometer, compare liquid temperature to outdoor ambient temperature.

Approach Temperature = Liquid temperature (at condenser outlet) minus ambient temperature.

- 2- Approach temperatures should match values in table 7. An approach temperature greater than this value indicates an undercharge. An approach temperature less than this value indicates an overcharge.
- 3- Do not use the approach method if system pressures do not match pressures in tables 5 through 6. The approach method is not valid for grossly over or undercharged systems.

**TABLE 7
APPROACH TEMPERATURES**

Unit	Liquid Temp. Minus Ambient Temp.	
	1st Stage	2nd Stage
180 & 240	12°F ± 1 (6.7°C ± 0.5)	12°F ± 1 (6.7°C ± 0.5)

V- SYSTEMS SERVICE CHECKS

A-Cooling System Service Checks

Units are factory charged and require no further adjustment; however, charge should be checked periodically using the approach method. The approach method compares actual liquid temperature with the outdoor ambient temperature. See section IV- CHARGING.

NOTE - When unit is properly charged discharge line pressures should approximate those in tables 5 through 6.

VI-MAINTENANCE

⚠ CAUTION

Label all wires prior to disconnection when servicing controls. Wiring errors can cause improper and dangerous operation. Verify proper operation after servicing.

⚠ WARNING



Electric shock hazard. Can cause injury or death. Before attempting to perform any service or maintenance, turn the electrical power to unit OFF at disconnect switch(es). Unit may have multiple power supplies.

⚠ CAUTION

Electrical shock hazard. Turn off power to unit before performing any maintenance, cleaning or service operation on the unit.

⚠ CAUTION

Danger of sharp metallic edges. Can cause injury. Take care when servicing unit to avoid accidental contact with sharp edges.

⚠ WARNING

Product contains fiberglass wool. Disturbing the insulation in this product during installation, maintenance, or repair will expose you to fiberglass wool. Breathing this may cause lung cancer. (Fiberglass wool is known to the State of California to cause cancer.) Fiberglass wool may also cause respiratory, skin and eye irritation. To reduce exposure to this substance or for further information, consult material safety data sheets available from address shown on unit nameplate or contact your supervisor.

The unit should be inspected once a year by a qualified service technician.

A-Filters

Units are equipped with six 24 X 24 X 2" filters. Filters should be checked and replaced when necessary with filters of like kind and size. Take note of air flow direction marking on filter frame when reinstalling filters. See figure 14.

NOTE - Filters must be U.L.C. certified or equivalent for use in Canada.

B-Lubrication

All motors used in these units are factory lubricated, no further lubrication is required.

Blower shaft bearings are prelubricated. For extended bearing life, relubricate at least once every two years with a lithium base grease such as Alvania 3 (Shell Oil), Chevron BRB2 (Standard Oil) or Regal AFB2 (Texas Oil). Use a hand grease gun for lubrication. Add only enough grease to purge through the bearings so that a bead of grease appears at the seal lip contacts.

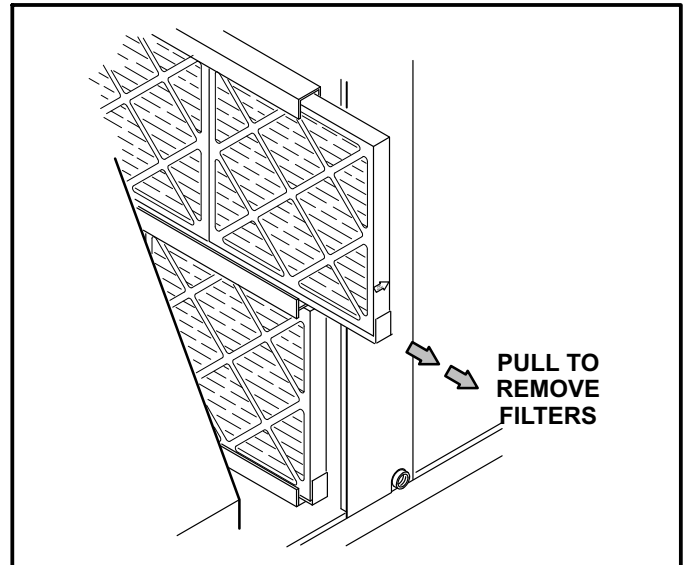

FIGURE 14

C-Indoor Coil

Inspect and clean coil at beginning of each cooling season. Clean using mild detergent or commercial coil cleaner. Flush coil and condensate drain with water taking care not to get insulation, filters and return air ducts wet.

D-Supply Air Blower Wheel

Annually inspect supply air blower wheel for accumulated dirt or dust. Turn off power before attempting to remove access panel or to clean blower wheel.

E-Electrical

- 1- Check all wiring for loose connections.
- 2- Check for correct voltage at unit (unit operating).
- 3- Check amp-draw on both condenser fan motor and blower motor.

Fan Motor Rating Plate ____ Actual _____

Indoor Blower Motor Rating Plate ____ Actual _____

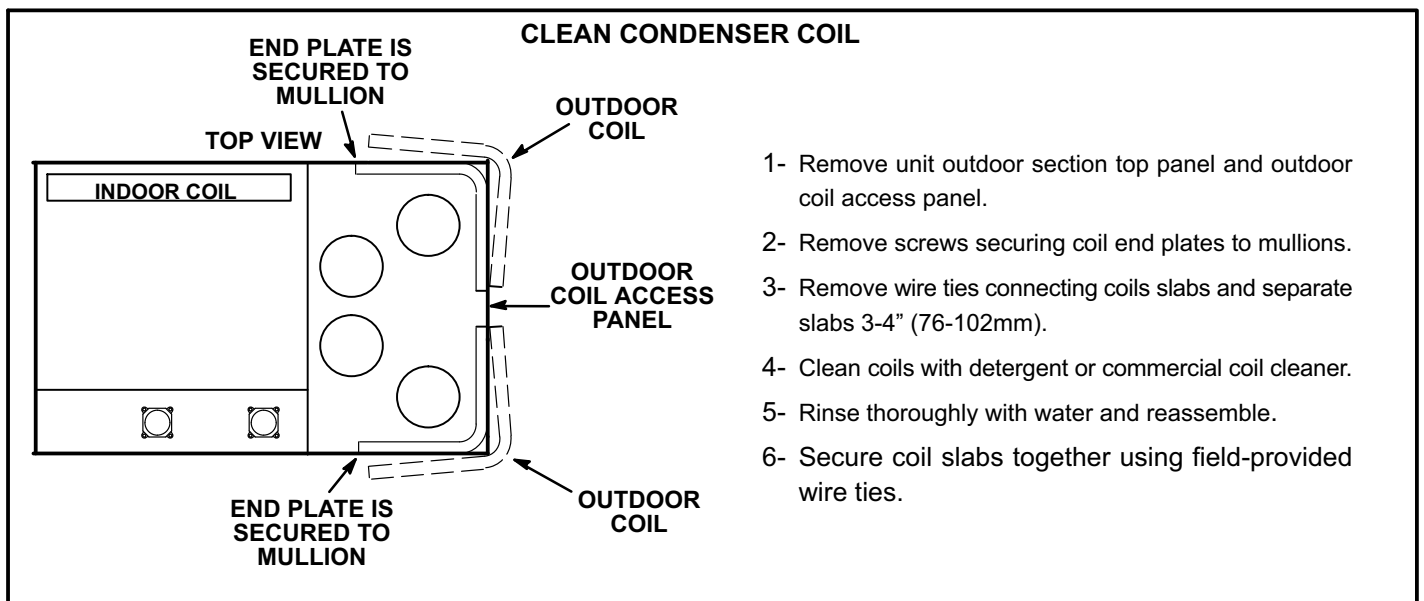

FIGURE 15

F-Condenser Coil

Clean condenser coil annually with detergent or commercial coil cleaner and inspect monthly during the cooling season. Access panels are provided on the front and back of the condenser section.

Outdoor coils are made of two formed slabs. Dirt and debris may become trapped between the slabs. To clean between slabs, carefully separate coil slabs and wash them thoroughly. See figure 15. Flush coils with water following cleaning.

NOTE - Remove all screws and gaskets prior to cleaning procedure and replace upon completion.

VII-OPTIONAL ACCESSORIES

The accessories section describes the application of most of the optional accessories.

A-C1CURB, LARMF and LARMFH Mounting Frames

When installing units on a combustible surface for down-flow discharge applications, the C1CURB40 (8-inch), or LARMF18/30S or 18/36 14-inch, 18-inch or 24-inch (356 mm or 610mm) roof mounting frame is used. An adjustable, pitched curb (L1CURB55C) is also available. For horizontal discharge applications, use LARMFH18/24 26-inch or 37-inch (660mm or 940mm) roof mounting frame. This frame converts unit from downflow to horizontal air flow. The roof mounting frames are recommended in all other applications but not required. If the units are not mounted on a flat (roof) surface, they **MUST** be supported under all edges and under the middle of the unit to prevent sagging. The units **MUST** be mounted level within 1/16" per linear foot or 5mm per meter in any direction.

The assembled mounting frame is shown in figure 16. Refer to the roof mounting frame installation instructions for details of proper assembly and mounting. The roof mounting frame **MUST** be squared to the roof and level before

mounting. Plenum system **MUST** be installed before the unit is set on the mounting frame. Typical roof curbing and flashing is shown in figure 17. Refer to the roof mounting frame installation instructions for proper plenum construction and attachment.

B-Transitions

Optional supply/return transitions LASRT18 and LASRT21/24 are available for use with units utilizing optional LARMF18/36 roof mounting frame. Transition must be installed in the mounting frame before setting the unit on the frame. Refer to the manufacturer's instructions included with the transition for detailed installation procedures.

C-Supply and Return Diffusers (all units)

Optional flush mount diffuser/return FD11 and extended mount diffuser/return RTD11 are available for use with all units. Refer to manufacturer's instructions included with transition for detailed installation procedures.

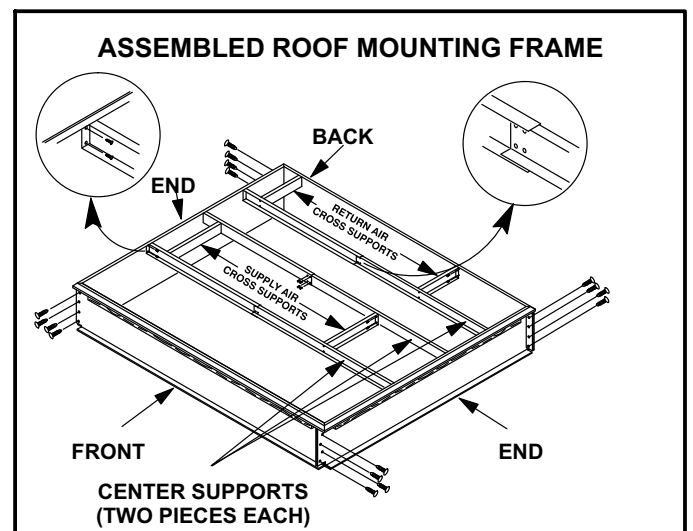

FIGURE 16

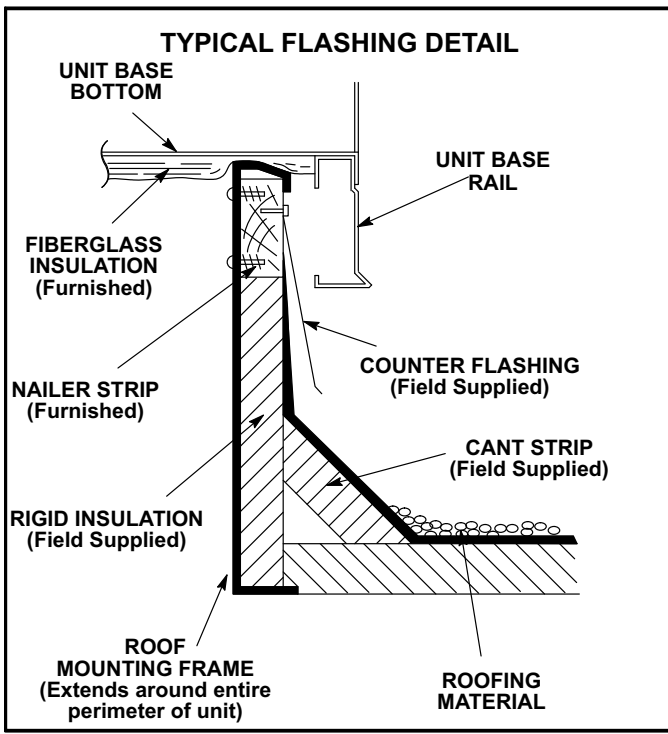

FIGURE 17

D-K1ECON20C Economizer

Unit may contain an optional modulating economizer equipped with an A6 enthalpy control and an S175 outdoor temperature sensor or A7 enthalpy sensor. The economizer modulates to use outdoor air for free cooling when temperature is suitable.

The A6 enthalpy control is located in the economizer access area. See figure 18. The S175 temperature sensor or A7 enthalpy sensor is located on the division panel between horizontal supply and return air sections.

Optional Sensors

An optional differential sensor (A62) may be used with the A7 outdoor sensor to compare outdoor air enthalpy to return air enthalpy. When the outdoor air enthalpy is below the return air enthalpy, outdoor air is used for free cooling.

A mixed air sensor (R1) is used in modulating the dampers to 55°F (13°C) blower compartment air temperature.

An optional IAQ sensor (A63) may be used to lower operating costs by controlling outdoor air based on CO₂ level or room occupancy (also called demand control ventilation or DCV). Damper minimum position can be set lower than traditional minimum air requirements; dampers open to traditional ventilation requirements when CO₂ level reaches DCV (IAQ) setpoint.

Refer to instructions provided with sensors for installation.

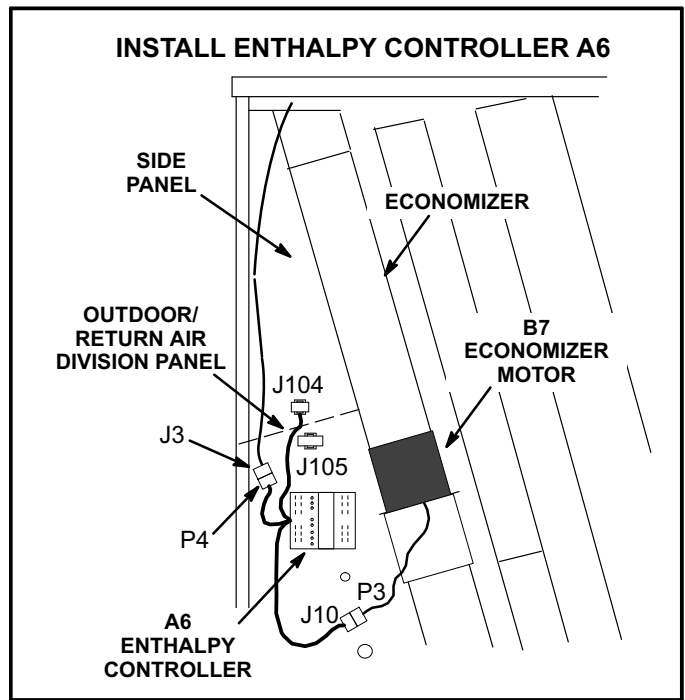

FIGURE 18

A6 Enthalpy Control LEDs

A steady green Free Cool LED indicates that outdoor air is suitable for free cooling.

When an optional IAQ sensor is installed, a steady green DCV LED indicates that the IAQ reading is higher than set-point requiring more fresh air. See figure 19.

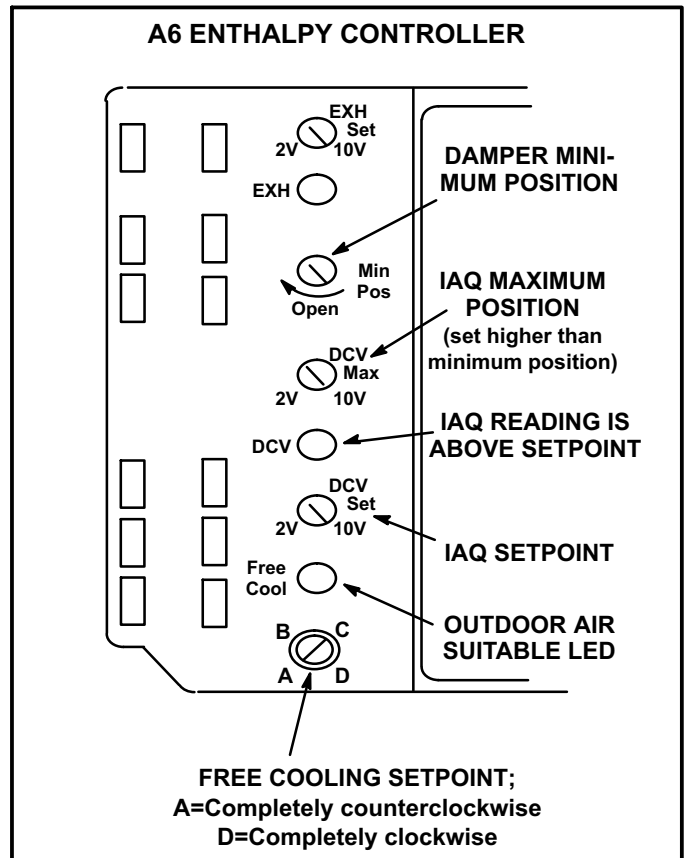

FIGURE 19

Free Cooling Setpoint

Single Temperature or Enthalpy Sensing:

The enthalpy control (A6) setpoint may be adjusted when an enthalpy (A7) sensor is used to determine outdoor air suitability. See figure 19.

Free cooling will be enabled when outdoor air temperature or enthalpy are lower than the free cooling setpoint. The free cooling setpoints for sensible temperature sensors is 55°F. Table 8 shows the free cooling setpoints for enthalpy sensors. Use the recommended setpoint and adjust as necessary.

For example: At setting A (table 8), free cooling will be enabled when outdoor air enthalpy is lower than 73°F and 50% RH. If indoor air is too warm or humid, lower the setpoint to B. At setting B, free cooling will be enabled at 70°F and 50% RH.

**TABLE 8
ENTHALPY FREE COOLING SETPOINTS**

Control Setting	Enthalpy Setpoint At 50% RH
A*	73° F (23° C)
B	70° F (21° C)
C	67° F (19° C)
D	63° F (17° C)

*Setting A is recommended.

Differential Sensing:

Two sensors can be used to compare outdoor air to return air. When outdoor air is cooler than return air, outdoor air is suitable for free cooling. Adjust the free cooling setpoint to "D" in this application.

When return air is cooler than outdoor air, the damper will modulate to the minimum position.

Damper Minimum Position

NOTE - A jumper is factory-installed between TB1 R and OC terminals to maintain occupied status (allowing minimum fresh air). See figure 20. When using an electronic thermostat or energy management system with an occupied/unoccupied feature, remove jumper. Make wire connections to R and OC as shown in literature provided with thermostat or energy management system literature. Either the jumper wire or optional device must be connected to R and OC for the economizer to function.

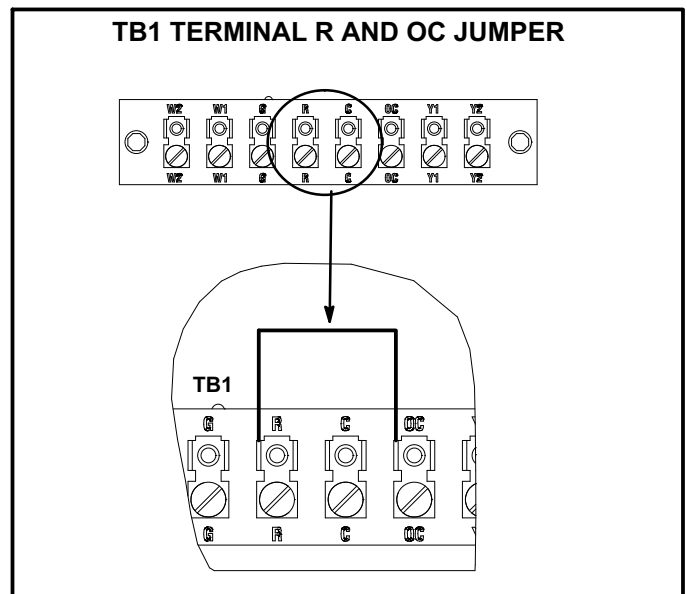

FIGURE 20

1- Set thermostat to occupied mode if the feature is available. Make sure jumper is in place between TB1 terminals R and OC if using a thermostat which does not have the feature.

2- Rotate MIN POS SET potentiometer to approximate desired fresh air percentage.

NOTE - Damper minimum position can be set lower than traditional minimum air requirements when an IAQ sensor is specified.

3- Measure outdoor air temperature. Mark the point on the bottom line of chart 1 and label the point "A" (40°F, 4°C shown).

4- Measure return air temperature. Mark that point on the top line of chart 1 and label the point "B" (74°F, 23°C shown).

5- Measure mixed air (outdoor and return air) temperature. Mark that point on the top line of chart 1 and label point "C" (70°F, 21°C shown).

6- Draw a straight line between points A and B.

7- Draw a vertical line through point C.

8- Draw a horizontal line where the two lines meet. Read the percent of fresh air intake on the side.

9- If fresh air percentage is less than desired, adjust MIN POS SET potentiometer clockwise (further open). If fresh air percentage is more than desired, adjust MIN POS SET potentiometer counterclockwise (less open). Repeat steps 3 through 8 until calculation reads desired fresh air percentage.

DCV Set and Max Settings

The DCV SET potentiometer is factory-set at approximately 50% of the potentiometer range. Using a standard 1-2000ppm CO₂ sensor, dampers will start to open when the IAQ sensor reads approximately 1000ppm. Adjust the DCV SET potentiometer to the approximate setting specified by the controls contractor. Refer to figure 19.

The DCV MAX potentiometer is factory-set at approximately 50% of the potentiometer range or 6VDC. Dampers will open approximately half way when CO₂ rises above setpoint. Adjust the DCV MAX potentiometer to the approximate setting specified by the controls contractor. Refer to figure 19.

NOTE - DCV Max must be set higher than economizer minimum position setting for proper demand control ventilation.

Economizer Operation

When the outdoor air is suitable, dampers will modulate be-

tween minimum position and full open to maintain 55°F (12.8°C) supply air.

See table 9 for economizer operation when outdoor air is suitable. See table 10 for economizer operation when outdoor air is NOT suitable.

IAQ Sensor

During the occupied period, dampers will open to DCV MAX when IAQ reading is above setpoint (regardless of thermostat demand or outdoor air suitability). DCV MAX will NOT override damper full-open position. The DCV MAX setting may override damper free cooling position when occupancy is high and outdoor air temperatures are low.

NOTE - R1 senses mixed air temperature below 45°F (7°C), dampers will move to minimum position until mixed air temperature rises to 48°F (9°C).

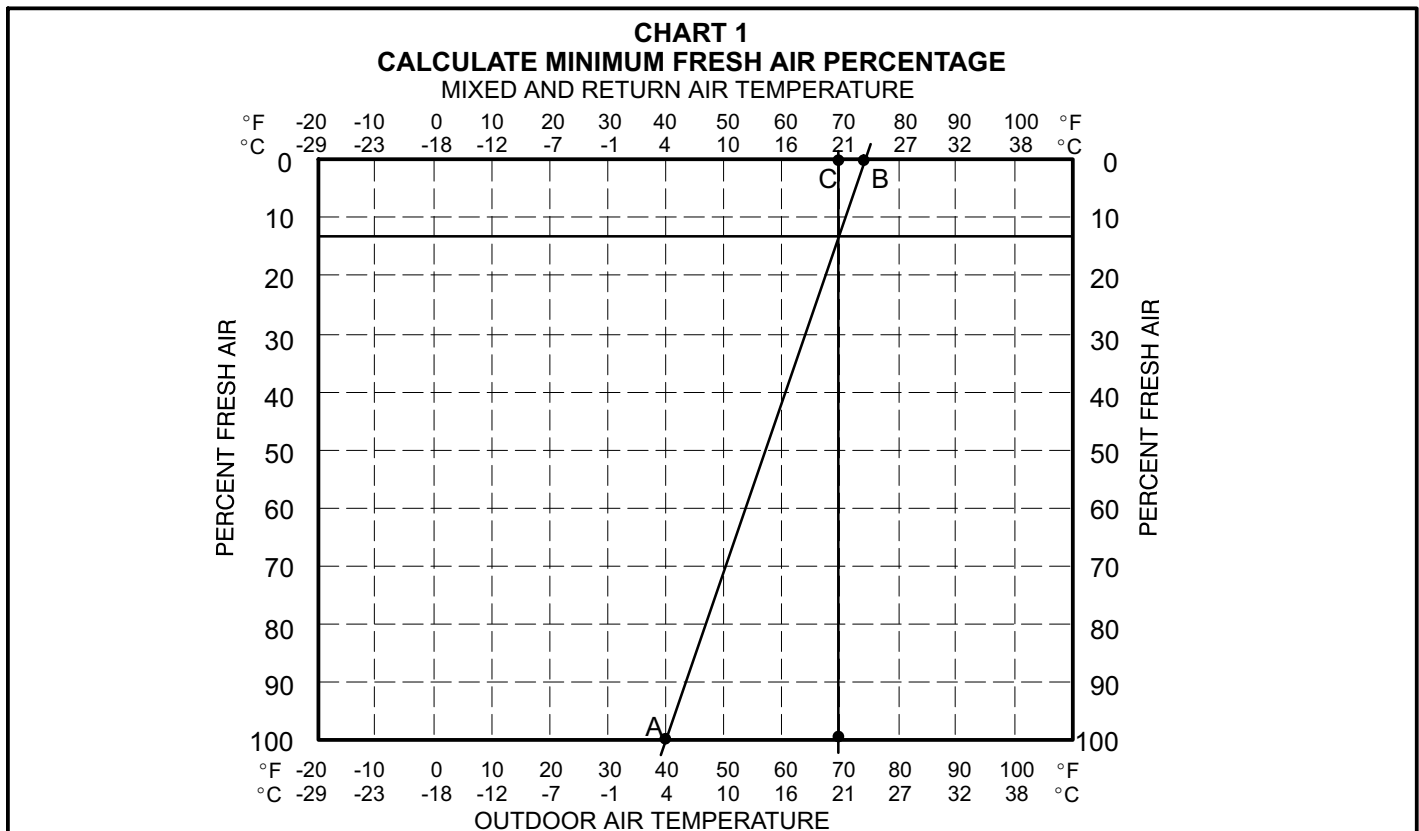

TABLE 9
ECONOMIZER OPERATION-OUTDOOR AIR IS SUITABLE FOR FREE COOLING – FREE COOL LED “ON”

THERMOSTAT DEMAND	DAMPER POSITION		MECHANICAL COOLING
	UNOCCUPIED	OCCUPIED	
Off	Closed	Closed	No
G	Closed	Minimum	No
Y1	Modulating	Modulating	No
Y2	Modulating	Modulating	Stage 1

TABLE 10
ECONOMIZER OPERATION-OUTDOOR AIR IS NOT SUITABLE FOR FREE COOLING – FREE COOL LED “OFF”

THERMOSTAT DEMAND	DAMPER POSITION		MECHANICAL COOLING
	UNOCCUPIED	OCCUPIED	
Off	Closed	Closed	No
G	Closed	Minimum*	No
Y1	Closed	Minimum*	Stage 1
Y2	Closed	Minimum*	Stage 2

*IAQ sensor can open damper to DCV max.

B-Outdoor Air Dampers

Both manual (C1DAMP10C) and motorized (K1DAMP20C) outdoor air dampers are available for use with these units to allow outside air into the system (see figure 21). The motorized damper assembly opens to minimum position during the occupied time period and remains closed during the unoccupied period. The position of the manual damper assembly is set at installation and remains in that position. See figure 22. Washable filter supplied with the outdoor air dampers can be cleaned with water and a mild detergent. It should be sprayed with Filter Handicoater when dry prior to reinstallation. Filter Handicoater is R.P. Products coating no. 418 and is available as Part No. P-8-5069.

Follow the steps to determine fresh air percentage

- 1- Measure outdoor air temperature. Mark the point on the bottom line of chart 1 and label the point “A” (40°F, 4°C shown).
- 2- Measure return air temperature. Mark that point on the

top line of chart 1 and label the point “B” (74°F, 23°C shown).

- 3- Measure mixed air (outdoor and return air) temperature. Mark that point on the top line of chart 1 and label point “C” (70°F, 21°C shown).
- 4- Draw a straight line between points A and B.
- 5- Draw a vertical line through point C.
- 6- Draw a horizontal line where the two lines meet. Read the percent of fresh air intake on the side.
- 7- If fresh air percentage is less than desired, adjust thumb wheel higher. If fresh air percentage is more than desired, adjust thumb wheel lower. Repeat steps until calculation reads desired fresh air percentage. See figure 23.

Set damper minimum position in the same manner as economizer minimum position. Adjust motorized damper position using the thumb wheel on the damper motor. See figure 23. Manual damper fresh air intake percentage can be determined in the same manner.

OUTDOOR AIR DAMPER

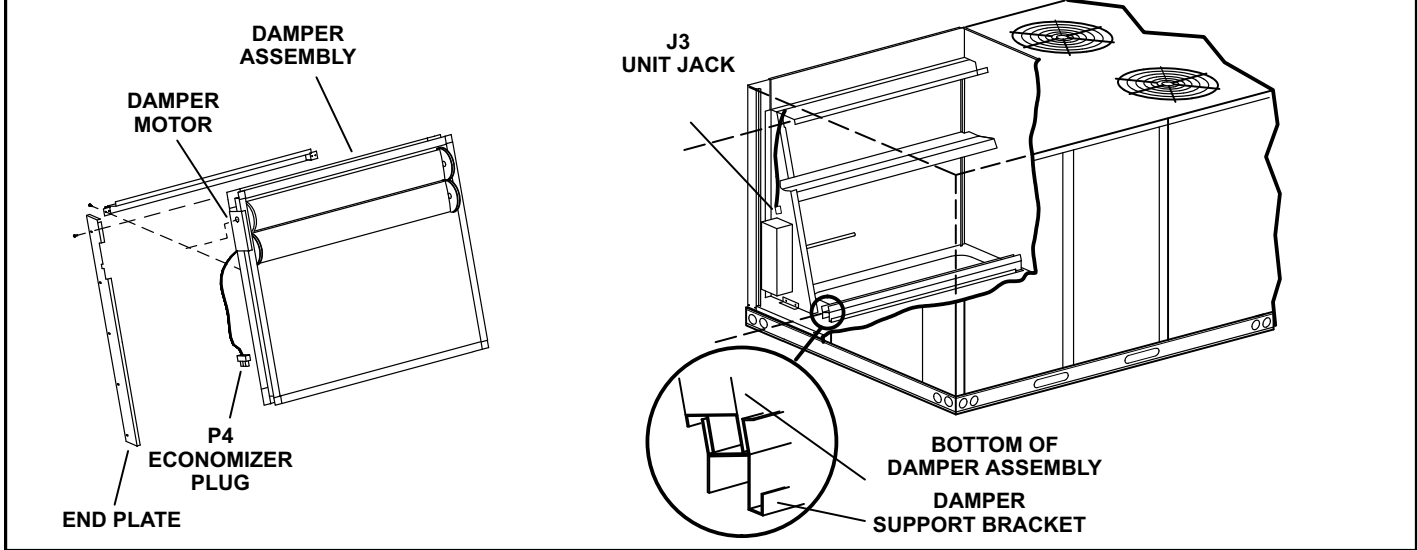

FIGURE 21

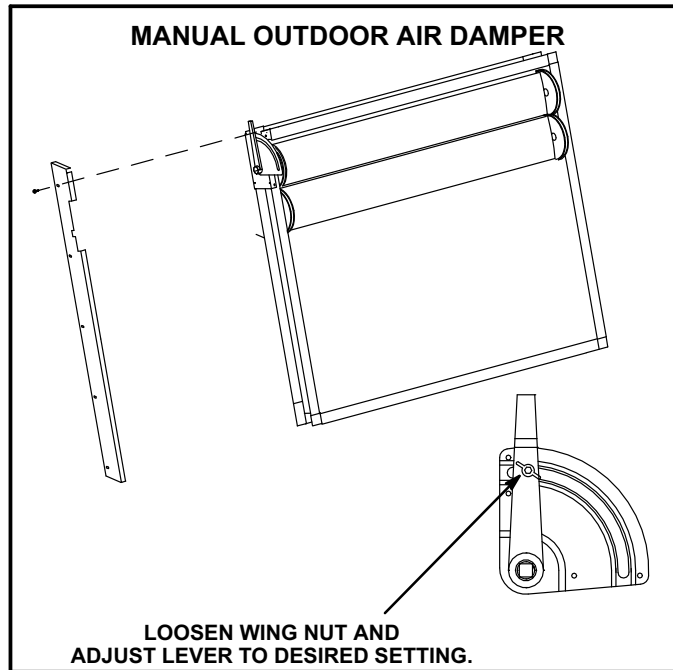

FIGURE 22

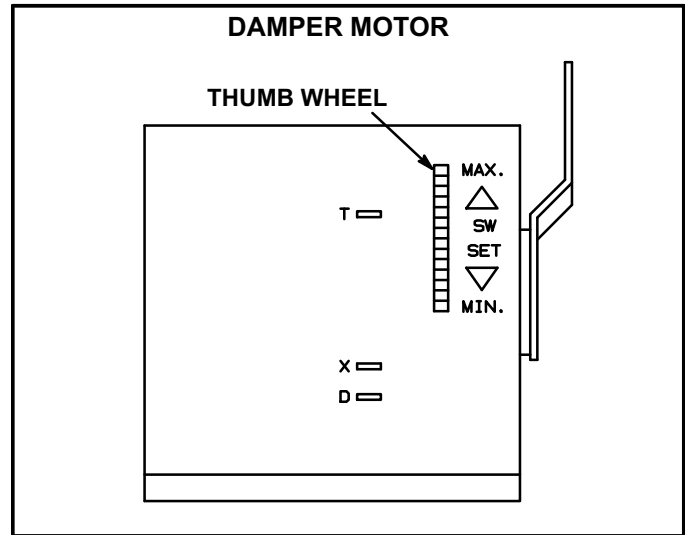

FIGURE 23

E-Barometric Relief / Gravity Exhaust Dampers

C1DAMP50 (figure 24) are used in downflow and LAGEDH18/24 are used in horizontal air discharge applications to provide barometric relief / gravity exhaust for the system. LAGEDH barometric relief / gravity exhaust dampers are installed in the return air plenum . The dampers must be used any time an economizer or power exhaust fans are installed.

Barometric relief / gravity exhaust dampers allow exhaust air to be discharged from the system when an economizer and/or power exhaust is operating. These dampers also prevent outdoor air infiltration during unit off cycle. See installation instructions for more detail.

F-C1PWRE10C Power Exhaust Fans

C1PWRE10C power exhaust fans are used in downflow applications only. The fans require optional downflow barometric relief / gravity exhaust dampers and K1ECON economizers. Power exhaust fans provide exhaust air pressure relief and also run when return air dampers are closed and supply air blowers are operating. Figure 24 shows the location of the C1PWRE. See installation instructions for more detail.

G-Control Systems

Three different types of control systems may be used. All thermostat wiring is connected to terminal block TB1 located in the control box of the unit. Each thermostat has additional control options available. See thermostat installation instructions for more detail.

1- Electro-mechanical thermostat (13F06)

The electro-mechanical thermostat is a two-stage heat / two-stage cool thermostat with dual temperature levers. A non-switching or manual system switch subbase may be used.

2- Electronic thermostat (see price book)

Any two-stage heat / two-stage cool electronic thermostat may be used.

3- Honeywell T7300 thermostat (81G59)

The Honeywell T7300 thermostat is a programmable, internal or optional remote temperature sensing thermostat. The T7300 provides occupied and unoccupied changeover control.

H-Smoke Detectors A171 and A172

Photoelectric smoke detectors are a field installed option. The smoke detectors can be installed in the supply air section (A172), return air section (A171), or in both the supply and return air section.

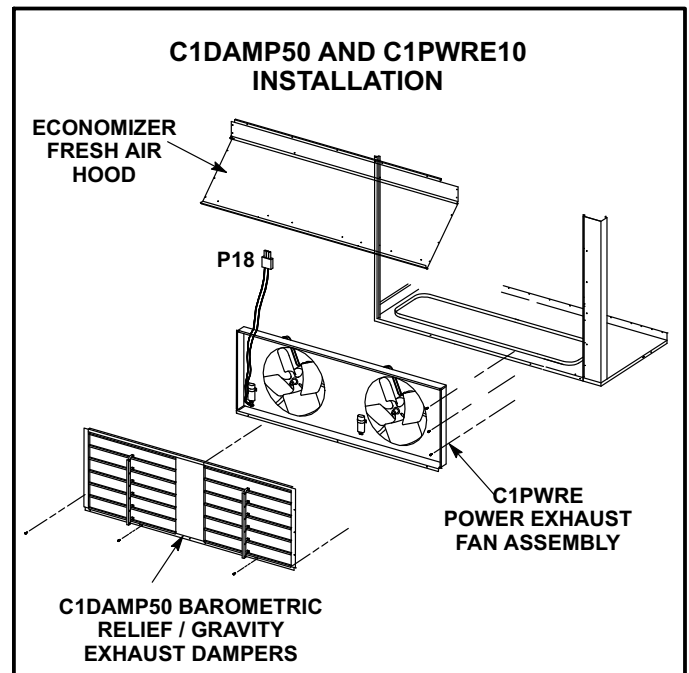

FIGURE 24

I-Indoor Air Quality (CO₂) Sensor A63

The indoor air quality sensor monitors CO₂ levels and reports the levels to the economizer control module A6. The board adjusts the economizer dampers according to the CO₂ levels. The sensor is mounted next to the indoor thermostat or in the return air duct. Refer to the indoor air quality sensor installation instructions for proper adjustment.

J-UVC Kit

UVC germicidal lamps are a field-installed option. The lamp emits ultraviolet light that greatly reduces the growth and proliferation of mold and other bio-aerosols on illuminated surfaces. The lamp is mounted in the blower compartment with the light directed towards the indoor coil. For more details refer to the installation instructions provided with the UVC lamp.

K-Drain Pan Overflow Switch S149 (optional)

The overflow switch is used to interrupt cooling operation when excessive condensate collects in the drain pan. The N.O. overflow switch is controlled by K220 and DL46 relays, located in the unit control panel. When the overflow switch closes, 24VAC power is interrupted and after a five-second delay unit compressors are de-energized. Once the condensate level drops below the set level, the switch will open. After a five-minute delay the compressor will be energized.

KHA180, 240 UNIT DIAGRAM

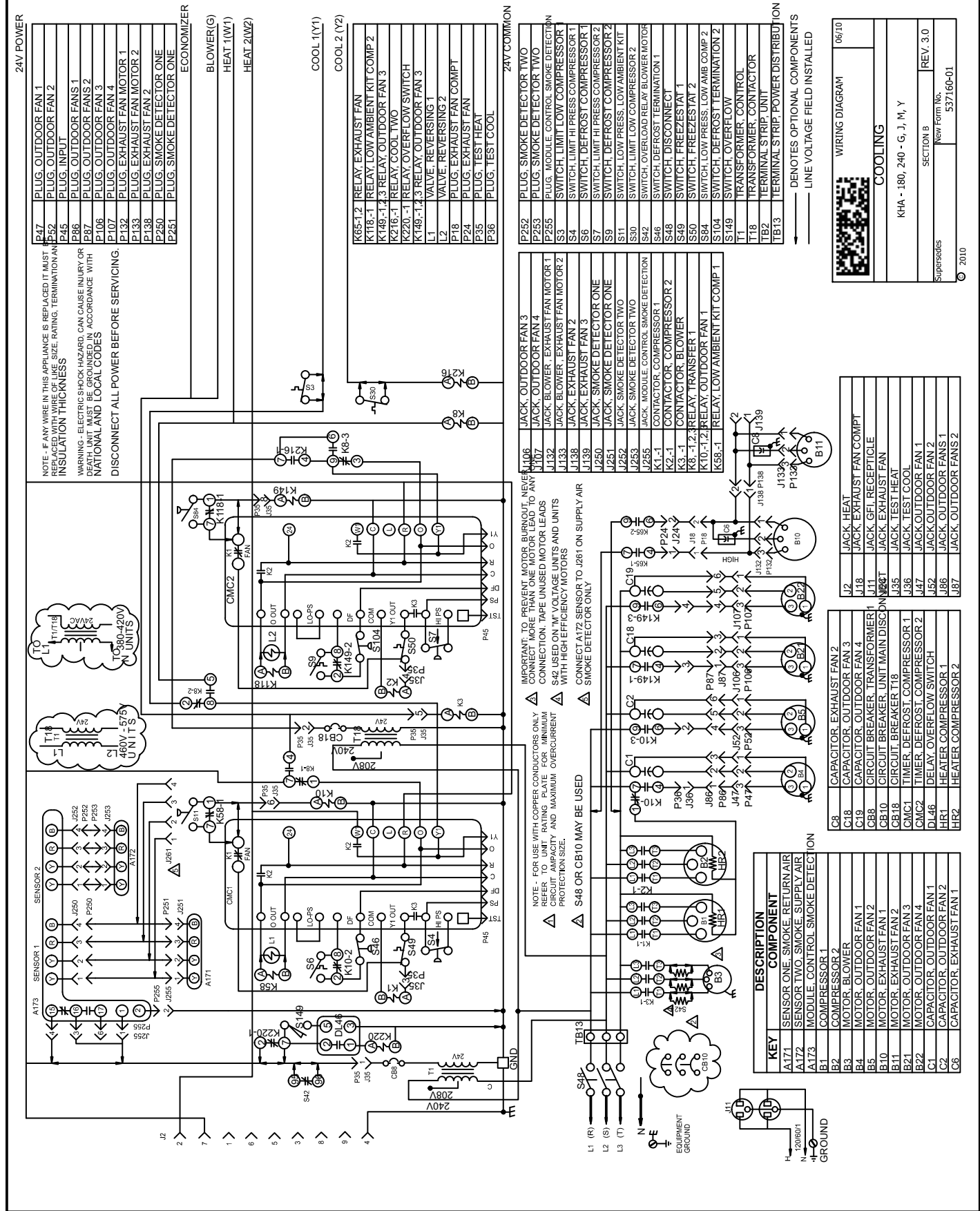

NOTE - IF ANY WIRE IN THIS APPLIANCE IS REPLACED IT MUST BE THE SAME SIZE, RATING, TERMINATION AND INSULATION THICKNESS

WARNING - ELECTRIC SHOCK HAZARD, CAN CAUSE INJURY OR DEATH. UNIT MUST BE GROUNDED IN ACCORDANCE WITH NATIONAL AND LOCAL CODES. DISCONNECT ALL POWER BEFORE SERVICING.

24V POWER

P47	PLUG, OUTDOOR FAN 1
P48	PLUG, OUTDOOR FAN 2
P49	PLUG, INPUT
P86	PLUG, OUTDOOR FAN 1
P87	PLUG, OUTDOOR FAN 2
P106	PLUG, OUTDOOR FAN 3
P107	PLUG, OUTDOOR FAN 4
P132	PLUG, EXHAUST FAN MOTOR 1
P133	PLUG, EXHAUST FAN MOTOR 2
P250	PLUG, SMOKE DETECTOR ONE
P251	PLUG, SMOKE DETECTOR ONE

ECONOMIZER

BLOWER(G)	BLOWER(G)
HEAT 1(W1)	HEAT 1(W1)
HEAT 2(W2)	HEAT 2(W2)

COOL 1(Y1)

K65-1,2	RELAY, EXHAUST FAN
K118-1	RELAY, LOW AMBIENT KIT COMP 2
K149-1,2,3	RELAY, OUTDOOR FAN 3
K216-1	RELAY, COOL TWO
K220-1	RELAY, OVERFLOW SWITCH
K149-1,2,3	RELAY, OUTDOOR FAN 3
L1	VALVE, REVERSING 1
L2	VALVE, REVERSING 2
P18	PLUG, EXHAUST FAN COMPT
P24	PLUG, EXHAUST FAN
P35	PLUG, TEST HEAT
P36	PLUG, TEST COOL

COOL 2 (Y2)

K118-1	RELAY, EXHAUST FAN
K149-1,2,3	RELAY, OUTDOOR FAN 3
K216-1	RELAY, COOL TWO
K220-1	RELAY, OVERFLOW SWITCH
K149-1,2,3	RELAY, OUTDOOR FAN 3
L1	VALVE, REVERSING 1
L2	VALVE, REVERSING 2
P18	PLUG, EXHAUST FAN COMPT
P24	PLUG, EXHAUST FAN
P35	PLUG, TEST HEAT
P36	PLUG, TEST COOL

24V COMMON

P252	PLUG, SMOKE DETECTOR TWO
P253	PLUG, SMOKE DETECTOR TWO
P255	PLUG, MODULE, CONTROL SMOKE DETECTION
S3	SWITCH, LIMIT LOW COMPRESSOR
S4	SWITCH, LIMIT HI PRESS COMPRESSOR 1
S6	SWITCH, DEFROST COMPRESSOR 1
S7	SWITCH, LIMIT HI PRESS COMPRESSOR 2
S9	SWITCH, DEFROST COMPRESSOR 2
S10	SWITCH, LOW PRESS, LOW AMBIENT KIT
S30	SWITCH, LIMIT LOW COMPRESSOR 2
S42	SWITCH, OVERLOAD RELAY BLOWER MOTOR
S46	SWITCH, DEFROST TERMINATION 1
S48	SWITCH, DISCONNECT
S49	SWITCH, FREEZES TAT 1
S50	SWITCH, FREEZES TAT 2
S84	SWITCH, LOW PRESS, LOW AMB COMP 2
S104	SWITCH, DEFROST TERMINATION 2
S149	SWITCH, OVERFLOW
T1	TRANSFORMER, CONTROL
T18	TRANSFORMER, CONTACTOR
TB2	TERMINAL STRIP, UNIT
TB13	TERMINAL STRIP, POWER DISTRIBUTION

← DENOTES OPTIONAL COMPONENTS
— LINE VOLTAGE FIELD INSTALLED

IMPORTANT: TO PREVENT MOTOR BURNOUT, NEVER CONNECT MORE THAN ONE MOTOR LEAD TO ANY JACK. BLOWER, EXHAUST MOTOR LEADS S42 USED ON M VOLTAGE UNITS AND UNITS WITH HIGH EFFICIENCY MOTORS

J106	JACK, OUTDOOR FAN 3
J107	JACK, OUTDOOR FAN 4
J132	JACK, BLOWER, EXHAUST FAN MOTOR 1
J133	JACK, BLOWER, EXHAUST FAN MOTOR 2
J138	JACK, EXHAUST FAN 2
J139	JACK, EXHAUST FAN 3
J251	JACK, SMOKE DETECTOR ONE
J252	JACK, SMOKE DETECTOR TWO
J253	JACK, SMOKE DETECTOR TWO
J255	JACK, MODULE, CONTROL SMOKE DETECTION
K1-1	CONTACTOR, COMPRESSOR 1
K2-1	CONTACTOR, COMPRESSOR 2
K8-1,2	RELAY, TRANSFER 1
K10-1,2	RELAY, OUTDOOR FAN 1
K58-1	RELAY, LOW AMBIENT KIT COMP 1

KEY	DESCRIPTION COMPONENT
A173	SENSOR ONE, SMOKE, RETURN AIR
A172	SENSOR TWO, SMOKE, SUPPLY AIR
A173	MODULE, CONTROL SMOKE DETECTION
B1	COMPRESSOR 1
B2	COMPRESSOR 2
B3	MOTOR, BLOWER
B4	MOTOR, OUTDOOR FAN 1
B5	MOTOR, OUTDOOR FAN 2
B10	MOTOR, EXHAUST FAN 2
B11	MOTOR, EXHAUST FAN 1
B22	MOTOR, OUTDOOR FAN 3
C1	CAPACITOR, OUTDOOR FAN 1
C2	CAPACITOR, OUTDOOR FAN 2
C6	CAPACITOR, EXHAUST FAN 1
C8	CAPACITOR, EXHAUST FAN 2
C18	CAPACITOR, OUTDOOR FAN 3
C19	CAPACITOR, OUTDOOR FAN 4
CB8	CIRCUIT BREAKER, TRANSFORMER 1
CB10	CIRCUIT BREAKER, UNIT MAIN DISC
CB18	CIRCUIT BREAKER, T18
CMC1	TIMER, DEFROST, COMPRESSOR 1
CMC2	TIMER, DEFROST, COMPRESSOR 2
DL46	DELAY, OVERFLOW SWITCH
HR1	HEATER, COMPRESSOR 1
HR2	HEATER, COMPRESSOR 2
J12	JACK, HEAT
J18	JACK, EXHAUST FAN COMPT
J11	JACK, GFI RECEPTACLE
J19	JACK, EXHAUST FAN
J35	JACK, TEST HEAT
J36	JACK, TEST COOL
J47	JACK, OUTDOOR FAN 1
J52	JACK, OUTDOOR FAN 2
J86	JACK, OUTDOOR FAN 1
J87	JACK, OUTDOOR FAN 2

WIRING DIAGRAM 06/10

COOLING

KHA - 180, 240 - G, J, M, Y

SECTION B

REV. 3.0

New Form No. 557160-01

Supersedes

© 2010

KHA180, 240 SEQUENCE OF OPERATION

Power:

- 1- Line voltage from TB13 energizes transformer T1 and T18. T1 provides 24VAC to the unit cooling, heating, blower controls, CMC1, CMC2, reversing valve L1 and TB1. T18 provides 24VAC to reversing valve L2.

Blower Operation:

- 2- TB1 receives a demand from thermostat terminal G and energizes blower contactor K3 24VAC.
- 3- N.O. K3 closes, energizing blower B3.

Optional Power Exhaust Operation:

- 4- The economizer control module receives a demand and energizes exhaust fan relay K65 with 24VAC at 50% outside air damper open (adjustable).
- 5- N.O. K65-1 and N.O. K65-2 both close, energizing exhaust fan motors B10 and B11.

1st Stage Cooling (compressor B1)

- 6- First stage cooling demand routed from thermostat provides 24VAC to Y1 and G on TB1. G energizes blower (see step 3-)
- 7- 24VAC routed from T1 energizes reversing valve L1.
- 8- 24VAC routed from CMC1 proving N.C. high pressure switch S4 and N.C. freezestat S49. Compressor contactor K1 is energized.
- 9- K1 closes energizing compressor B1.
- 10- 24VAC is routed through optional optional N.O. low ambient pressure switch S11 (now closed) to energize outdoor fan contactor K10.
- 11- N.O. K10-1 and K10-3 close energizing outdoor fan B4 and B5.

2nd Stage Cooling (compressor B2 is energized)

- 12- Second stage cooling demand energizes Y2.
- 13- 24VAC routed from T18 energizes reversing valve L2.
- 14- 24VAC is routed from CMC2 proving N.C. high pressure switch S7 to energize compressor contactor K2.
- 15- N.O. K2 closes energizing compressor B2.
- 16- 24VAC is routed through N.O. low ambient pressure switch S84 (now closed) to energize outdoor fan contactor K149.
- 17- N.O. K149-1 and K149-3 close energizing outdoor fan B21 and B22.

First Stage Heat (compressors B1 and B2)

NOTE: On first heating demand after unit has been in cooling mode, unit will de-energize reversing valves L1 and L2.

- 18- Heating demand energizes W1 in the thermostat.
- 19- CMC1 and CMC2 prove N.C. high pressure switches S4 and S7 and N.C. freezestats S49 and S50; compressor contactors K1 and K2 are energized.
- 20- K1 and K2 close energizing compressor B1 and B2.
- 21- 24VAC bypasses optional N.C. low ambient switches S11 and S84 to energize outdoor fan relays K10 and K149.
- 22- K10 and K149 close energizing outdoor fans B4, B5, B21 and B22.

Second Stage Heat (electric heat):

- 23- Second stage heat demand energizes W2 in the thermostat.
- 24- See sequence of operation for electric heat.

Defrost Mode

- 25- During heating operation, when outdoor coil drops to $35 \pm 4^\circ$ the defrost thermostat S6 or S9 closes initiating defrost (after minimum run time of 30, 60 or 90 minutes).
- 26- When defrost begins, the reversing valve L1 or L2 is energized. Supplemental electric heat (W2) is energized when stage 1 is in defrost mode.
- 27- When L1 energizes, outdoor fan relay K10 and outdoor fans B4 and B5 are de-energized. When L2 energizes, outdoor fan relay K149 and outdoor fans B21 and B22 are de-energized.
- 28- Defrost terminates when the pressure switch for the circuit S46 or S104 opens, or when 15 minutes has elapsed. The defrost cycle is **not** terminated when thermostat demand ends.

EHA-15, 30, 45, 60, 90kW Y VOLTAGE

DESCRIPTION	
KEY	COMPONENT
CB13	CIRCUIT, BREAKER TRNAS T2
DL2	DELAY, ELECTRIC HEAT
DL5	DELAY, ELECTRIC HEAT
F3	FUSE, ELECTRIC HEAT
F4	FUSE, UNIT
F42	FUSE, ELECTRIC HEAT
F43	FUSE, ELECTRIC HEAT
F44	FUSE, ELECTRIC HEAT
F45	FUSE, ELECTRIC HEAT
F46	FUSE, ELECTRIC HEAT
F51	FUSE, ELECTRIC HEAT
HE1	ELEMENT, ELECTRIC HEAT 1
HE2	ELEMENT, ELECTRIC HEAT 2
HE3	ELEMENT, ELECTRIC HEAT 3
HE4	ELEMENT, ELECTRIC HEAT 4
HE5	ELEMENT, ELECTRIC HEAT 5
HE6	ELEMENT, ELECTRIC HEAT 6
HE7	ELEMENT, ELECTRIC HEAT 7
HE8	ELEMENT, ELECTRIC HEAT 8
HE9	ELEMENT, ELECTRIC HEAT 9
HE10	ELEMENT, ELECTRIC HEAT 10
HE11	ELEMENT, ELECTRIC HEAT 11
HE12	ELEMENT, ELECTRIC HEAT 12
J7	JACK, ELECTRIC HEAT SUB-BASE KIT
J37	JACK, ELECTRIC HEAT LIMIT
K9,-1,2	RELAY, HEAT
K15,-1	CONTACTOR, ELECTRIC HEAT 1
K16,-1	CONTACTOR, ELECTRIC HEAT 2
K17,-1	CONTACTOR, ELECTRIC HEAT 3
K18,-1	CONTACTOR, ELECTRIC HEAT 4
K19,-1	RELAY, STAGE TWO HEAT

P2	PLUG, HEAT
P7	PLUG, ELECTRIC HEAT BUB BASE KIT
P37	PLUG, ELECTRIC HEAT LIMIT
S15	SWITCH, LIMIT PRIMARY ELECTRIC HEAT
S20	SWITCH, LIMIT SECONDARY ELECTRIC HEAT
S107	SWITCH, LIMIT PRIMARY ELECTRIC HEAT
S157	SWITCH, LIMIT SECONDARY ELECTRIC HEAT
S158	SWITCH, LIMIT SECONDARY ELECTRIC HEAT
S159	SWITCH, LIMIT SECONDARY ELECTRIC HEAT
S160	SWITCH, LIMIT SECONDARY ELECTRIC HEAT
S161	SWITCH, LIMIT SECONDARY ELECTRIC HEAT
T2	TRANSFORMER, ELECTRIC HEAT
TB2	TERMINAL STRIP, UNIT 2
TB3	TERMINAL STRIP, ELECTRIC HEAT
TB13	TERMINAL STRIP, POWER DISTRIBUTION

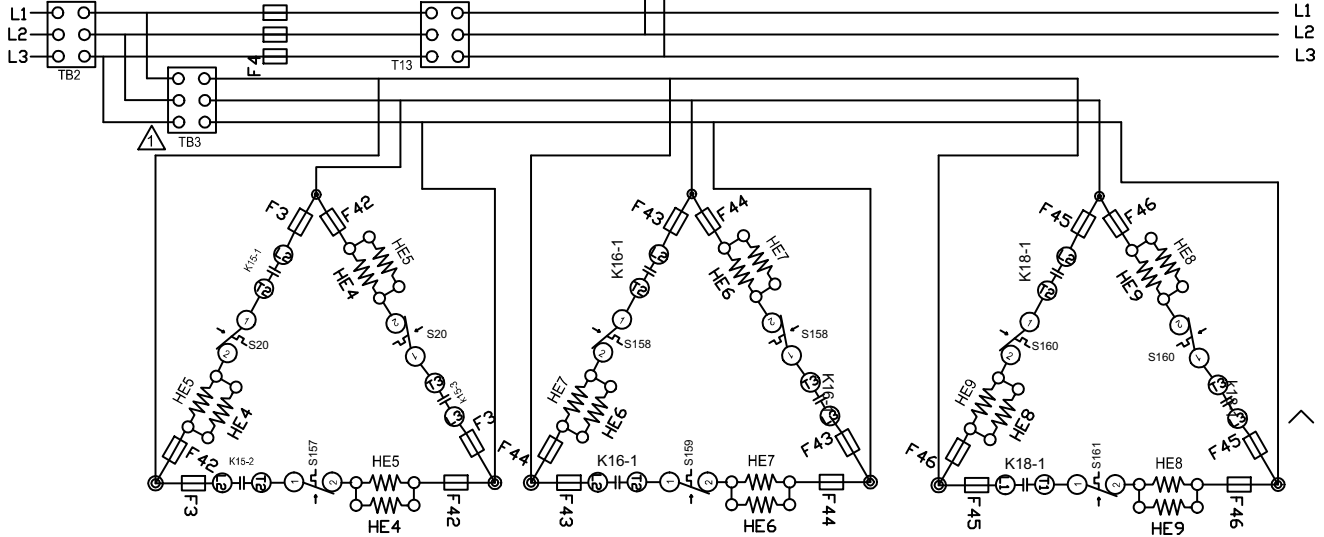

⚠ TB 3 IS USED IN SOME UNITS

C UNITS 180 TO 300

KW	HE1	HE2	HE3	HE4	HE5	HE6	HE7	HE8	HE9	HE10	HE11	HE12
15	7.5	7.5										
30				15	15							
45	15								7.5	15	7.5	
60	15								15	15	15	
90	15		15			15	15	15	15			

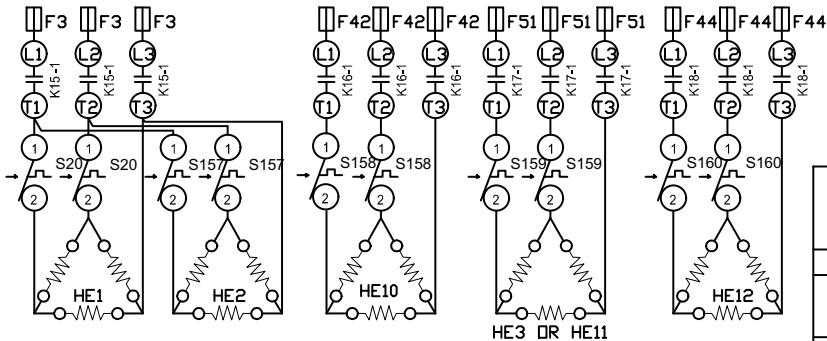

WIRING DIAGRAM
02/10

HEATING

EHA - 15, 30, 45, 60, 90 - Y
FOR USE WITH KCA AND KHA UNITS

SECTION A
REV. 3.0

Supersedes
535066W
New Form No.
537060-01

EHA-15, 30, 45, 60, 90kW - G, J, M VOLTAGE

DESCRIPTION	
KEY	COMPONENT
CB13	CIRCUIT, BREAKER TRNAS T2
DL2	DELAY, ELECTRIC HEAT
DL5	DELAY, ELECTRIC HEAT
F3	FUSE, ELECTRIC HEAT 1, 1A, 2A
F4	FUSE, UNIT
F43	FUSE, ELECTRIC HEAT 3, 4
F44	FUSE, ELECTRIC HEAT 5
F45	FUSE, ELECTRIC HEAT 6, 7
HE1	ELEMENT, ELECTRIC HEAT 1
HE1A	ELEMENT, ELECTRIC HEAT 1A
HE2A	ELEMENT, ELECTRIC HEAT 2
HE3	ELEMENT, ELECTRIC HEAT 3
HE4	ELEMENT, ELECTRIC HEAT 4
HE5	ELEMENT, ELECTRIC HEAT 5
HE6	ELEMENT, ELECTRIC HEAT 6
HE7	ELEMENT, ELECTRIC HEAT 7
J7	JACK, ELECTRIC HEAT SUB-BASE KIT
J37	JACK, ELECTRIC HEAT LIMIT
K9-1,2	RELAY, HEAT
K15-1	CONTACTOR, ELECTRIC HEAT 1
K16-1	CONTACTOR, ELECTRIC HEAT 2
K17-1	CONTACTOR, ELECTRIC HEAT 3
K18-1	CONTACTOR, ELECTRIC HEAT 4
K19-1	RELAY, STAGE TWO HEAT
P2	PLUG, HEAT
P7	PLUG, ELECTRIC HEAT BUB BASE KIT
P37	PLUG, ELECTRIC HEAT LIMIT
S15	SWITCH, LIMIT PRIMARY ELECTRIC HEAT
S20	SWITCH, LIMIT SECONDARY ELECTRIC HEAT 1A
S107	SWITCH, LIMIT PRIMARY ELECTRIC HEAT
S157	SWITCH, LIMIT SECONDARY ELECTRIC HEAT 2A
S158	SWITCH, LIMIT SECONDARY ELECTRIC HEAT 3,4
S159	SWITCH, LIMIT SECONDARY ELECTRIC HEAT 5
S160	SWITCH, LIMIT SECONDARY ELECTRIC HEAT 6,7

T2	TRANSFORMER, ELECTRIC HEAT
TB 2	TERMINAL STRIP, UNIT 2
TB 3	TERMINAL STRIP, ELECTRIC HEAT
TB15	TERMINAL STRIP, UNIT 2

⚠ TB3 IS USED IN SOME UNITS

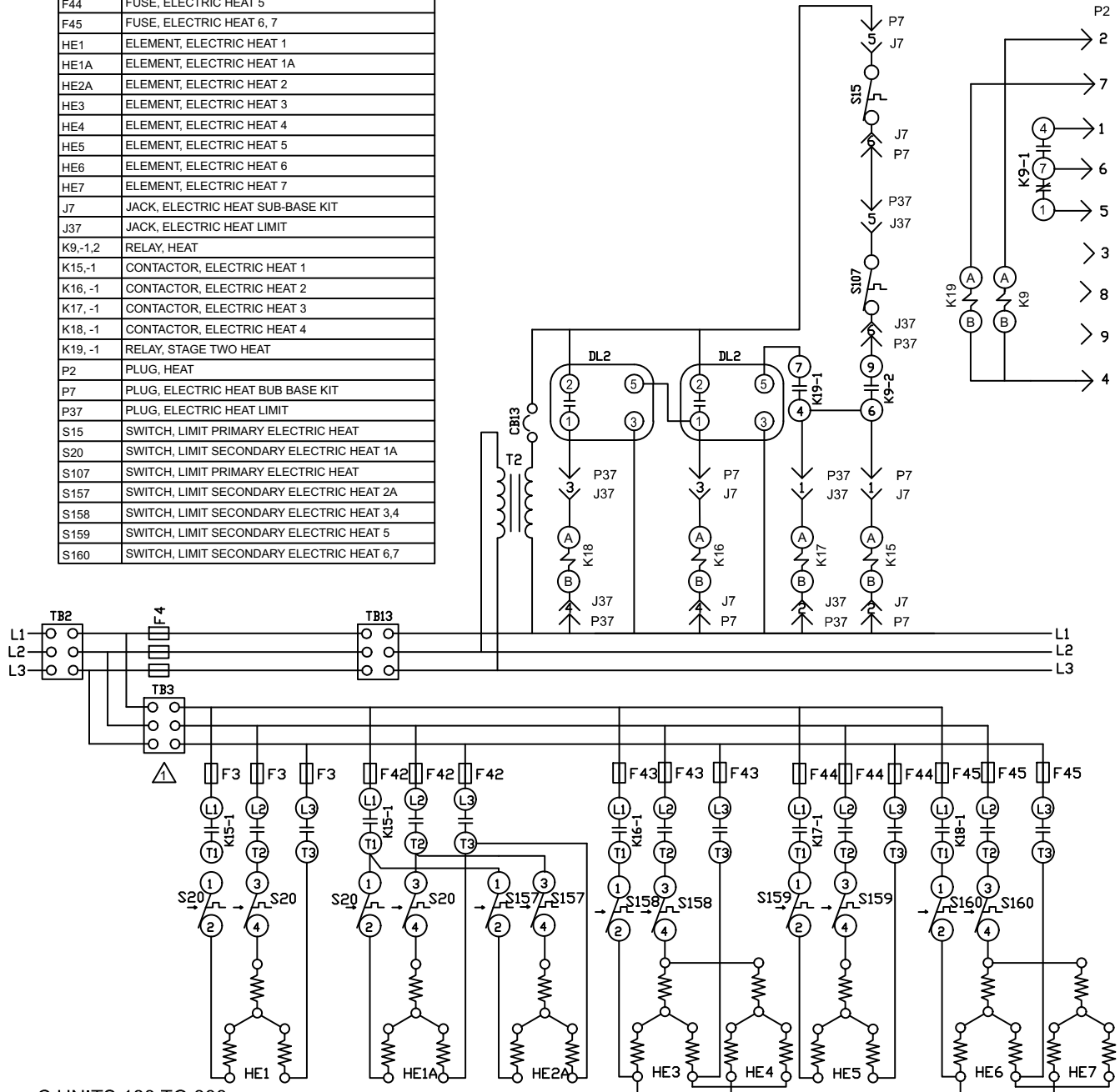

C UNITS 180 TO 300

KW	HE1	HE1A	HE2A	HE3	HE4	HE5	HE6	HE7
15		7.5	7.5					
30		15	15					
45	15			7.5		15	7.5	
60	15			15		15	15	
90	15			15	15	15	15	15

	WIRING DIAGRAM	05/10
	HEATING	
EHA - 15, 30, 45, 60, 90 - G, J FOR USE WITH KCA AND KHA UNITS		
SECTION A		REV. 0.0
Supersedes	New Form No. 537059-02	

© 2010

Sequence of Operation - EHA15 ,30, 45, 60, 90kW - Y, G, J and M

NOTE: This sequence of operation is for all Electric Heat kW ratings Y, G, J and M voltages.

HEATING ELEMENTS:

- 1- Terminal Strip TB2 supplies power to TB3. TB3 supplies line voltage to electric heat elements HE1 through HE7 in G, J and M volt units. TB3 supplies line voltage to electric heat elements HE1 through HE12 in Y volt units. Each element is protected by fuse F3.

SECOND STAGE HEAT DEMAND:

Heating demand initiates at W2 in thermostat.

- 2- 24VAC is routed from T2, proving N.C. primary limits S15 (first heat section) and S107 (second heat section). Voltage then energizes contactors K15 and K17. 24VAC is routed through P2 energizing relays K9 and K19. N.O. K9-2 and K19-1 close.
- 3- N.O. contact K15-1 closes allowing the first bank of elements to be energized. N.O. K17-1 closes allowing the second bank of elements to be energized.
- 4- Relay K19 is energized. N.O. contacts K19-1 close energizing timer DL2.

With the first stage heat operating, an additional heating demand initiates at W2 in the thermostat.

- 5- After a 30 second delay, DL2 closes energizing contactor K16 and timer DL5.
- 6- N.O. contacts K16-1 close allowing the third bank of elements to be energized.
- 7- After a 30 second delay, DL5 closes energizing contactor K18. K18-1 closes allowing the fourth bank of elements to be energized.

SECOND STAGE HEAT DEMAND SATISFIED:

Heating demand is satisfied. Terminal W2 in the thermostat is de-energized.

- 8- Electric heat contactors K15 and K17 are de-energized.
- 9- The second and first set of elements are de-energized.
- 10- Electric heat contactors K16 and K18 are de-energized.
- 11- The fourth and third set of elements are de-energized. Heating demand is satisfied. Terminal W2 in the thermostat is de-energized.

ELECTRONIC OR ELECTROMECHANICAL THERMOSTAT

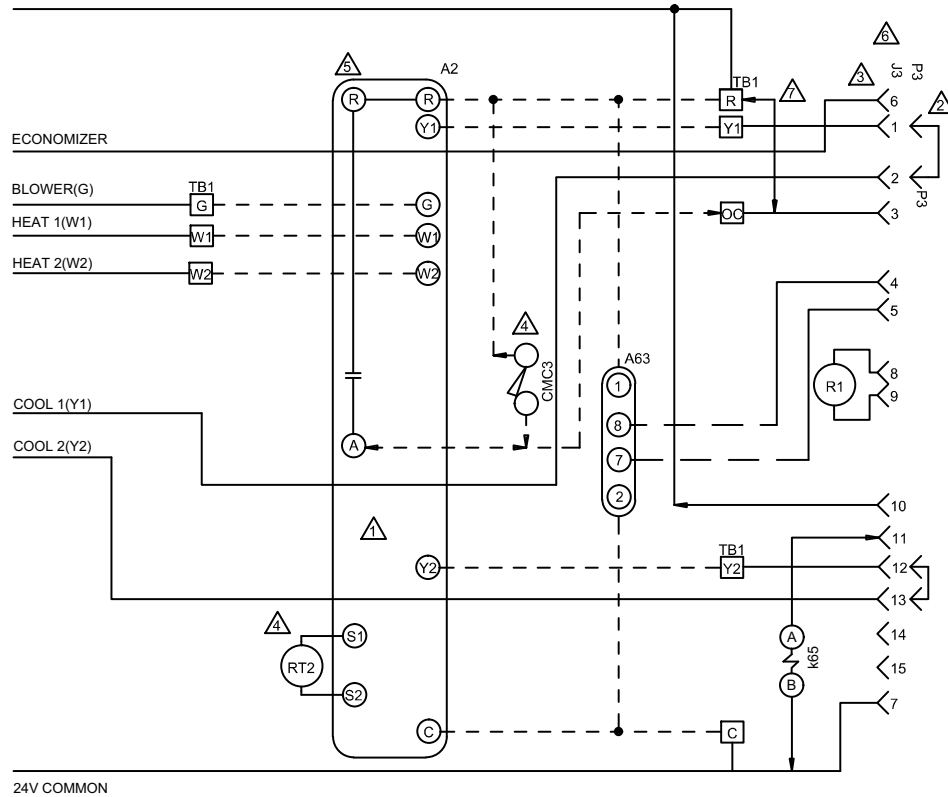

24V COMMON

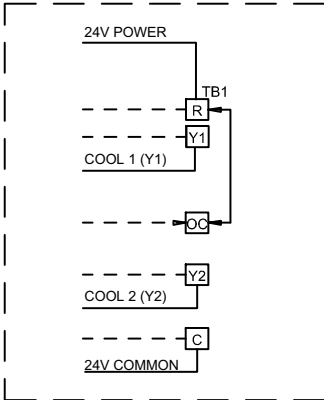

CONNECTION SCHEME FOR KCA, KGA AND KHA 092 THROUGH 150 UNITS WITHOUT ECONOMIZER ONLY

DESCRIPTION	
KEY	COMPONENT
A2	SENSOR, ELECTRONIC THERMOSTAT
A63	SENSOR, CO2
CMC3	CLOCK, TIME
J3	JACK, UNIT ECONOMIZER
K65	RELAY, EXHAUST FAN
P3	PLUG, ECONOMIZER BYPASS
R1	SENSOR, MIXED AIR OR SUPPLY AIR
RT2	SENSOR, REMOTE THERMOSTAT
TB1	TERMINAL STRIP, CLASS II VOLTAGE

- ⚠ THERMOSTAT SUPPLIED BY USER
- ⚠ REMOVE P3 WHEN ECONOMIZERS USED, ONLY ON KCA, KGA AND KHA 180 THROUGH 300 UNITS.
- ⚠ J3 MAXIMUM LOAD 20VA 24VAC CLASS II
- ⚠ TIME CLOCK CONTACTS (OPT) CLOSED OCCUPIED
- ⚠ TOUCHSCREEN THERMOSTAT
- ⚠ J3 AND P3 ARE NOT USED ON KCA, KGA AND KHA 092 THROUGH 150 UNITS WITHOUT ECONOMIZER
- ⚠ REMOVE JUMPER BETWEEN TB1-R AND TB1-OC WHEN USING A NITE SETBACK THERMOSTAT

— DENOTES OPTIONAL COMPONENTS
 - - - CLASS II FIELD WIRING

	WIRING DIAGRAM	12/09
ACCESSORIES		
ELECTRONIC OR ELECTROMECHANICAL THERMOSTAT		
SECTION C		REV. 2.0
Supersedes	New Form No. 537077-01	

© 2009

POWER:

- Terminal strip TB1 found on the control panel energizes thermostat components with 24VAC.

OPERATION:

- TB1 receives data from the electronic thermostat A2 (Y1, Y2, W1, W2, G, OCP)
 TB1 energizes the appropriate components for heat or cool demand.

KHA ECONOMIZER

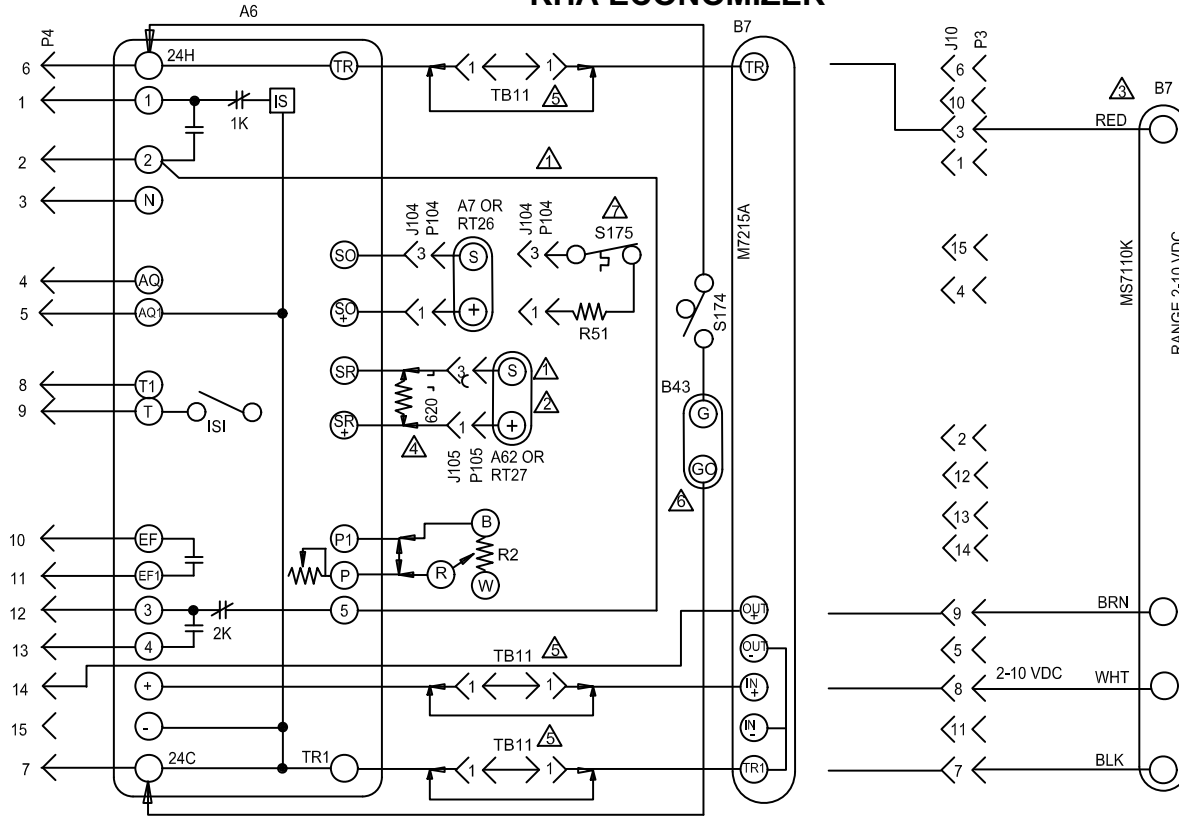

- ⚠ OPTIONAL OUTDOOR THERMOSTAT TO REPLACE RT26 SENSIBLE SENSOR
- ⚠ OPTIONAL EXHAUST DAMPER TO HOLD EXHAUST DAMPER CLOSED WHEN OUTSIDE AIR DAMPER IS CLOSED
- ⚠ TB11 USED ON "C" BOX ONLY WITH MOTOR M7215A
- ⚠ REPLACE A7 OR RT26 WITH 620 OHM RESISTOR FOR CONTROLS WITH GLOBAL ECON
- ⚠ USED ON C BOX UNITS
- ⚠ A62 ENTHALPY SENSOR OR RT27 USED FOR DIFFERENTIAL SENSING
- ⚠ RT26 AND RT27, TEMPERATURE SENSORS MAY BE USED INSTEAD OF A7 AND A62 ENTHALPY SENSORS

KEY	DESCRIPTION
A6	CONTROL-SOLID STATE ENTHALPY
A7	SENSOR-SOLID STATE ENTHALPY
A62	SENSOR-ENTHALPY, INDOOR
B7	MOTOR-DAMPER, ECONOMIZER
B43	MOTOR-EXHAUST DAMPER
J10	JACK-ECONOMIZER
J104	JACK-SENSOR,OUTDOOR ENTHALPY
J105	JACK-SENSOR,RETURN AIR ENTHALPY
P3	PLUG-LESS ECONOMIZER
P4	PLUG-ECONOMIZER
P104	PLUG-SENSOR,OUTDOOR ENTHALPY
P105	PLUG-SENSOR,RETURN AIR ENTHALPY
R2	POT-MINIMUM POSITION
R51	RESISTOR-SENSIBLE 820 OHM
RT26	SENSOR-OUTDOOR AIR TEMP
RT27	SENSOR-INDOOR AIR TEMP
S175	THERMOSTAT-SENSIBLE TEMP 55-70F
S174	SWITCH-EXHAUST DAMPER
TB11	TERMINAL STRIP-CLASS II VOLT

DESIGNATES OPTIONAL WIRING
 CLASS II FIELD WIRING

	WIRING DIAGRAM	5/09
ACCESSORIES		
ECONOMIZER		
ECONOMIZER SECTION D1		
Supersedes Form No.	New Form No. 537080-01	

© 2009 Litho U.S.A.

SEQUENCE OF OPERATION

POWER:

- 1- Economizer control module A6 is energized through P4 when contactor K3 is energized.

OPERATION:

- 2- Temperature sensor S175 or enthalpy sensor A7 and A62 (if differential enthalpy is used) communicates to the economizer control module A6 when to power the damper motor B7.
- 3- Economizer control module A6 supplies B7 with 0 - 10 VDC to control the positioning of economizer.
- 4- The damper actuator provides 2 to 10 VDC position feedback.