

## Service Literature

### LCH036 through 072

LCH036H, 048H, and 060H are high efficiency packaged units equipped with direct drive blowers. LCH036S, 048S, and 060S are standard efficiency packaged units equipped with two-speed, belt drive blowers. LCH072H is a high efficiency packaged unit equipped with a single-speed belt drive blower.

Optional electric heat is factory or field installed. Electric heat operates in single stage depending on the kW input size. 7.5kW through 30 kW heat sections are available for the LCH unit.

Information contained in this manual is intended for use by qualified service technicians only. All specifications are subject to change. Procedures outlined in this manual are presented as a recommendation only and do not supersede or replace local or state codes.

If the unit must be lifted for service, rig unit by attaching four cables to the holes located in the unit base rail (two holes at each corner). Refer to the installation instructions for the proper rigging technique.

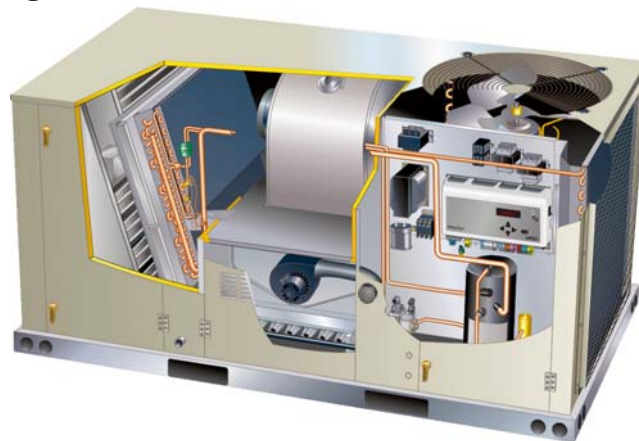

### ELECTROSTATIC DISCHARGE (ESD) Precautions and Procedures

#### ⚠ CAUTION

Electrostatic discharge can affect electronic components. Take precautions during unit installation and service to protect the unit's electronic controls. Precautions will help to avoid control exposure to electrostatic discharge by putting the furnace, the control and the technician at the same electrostatic potential. Neutralize electrostatic charge by touching hand and all tools on an unpainted unit surface, such as the blower deck, before performing any service procedure.

#### ⚠ WARNING

Improper installation, adjustment, alteration, service or maintenance can cause property damage, personal injury or loss of life. Installation and service must be performed by a licensed professional installer (or equivalent) or service agency.

#### ⚠ IMPORTANT

The Clean Air Act of 1990 bans the intentional venting of refrigerant (CFC's and HCFC's) as of July 1, 1992. Approved methods of recovery, recycling or reclaiming must be followed. Fines and/or incarceration may be levied for non-compliance.

#### ⚠ WARNING



Electric shock hazard. Can cause injury or death. Before attempting to perform any service or maintenance, turn the electrical power to unit OFF at disconnect switch(es). Unit may have multiple power supplies.

#### ⚠ CAUTION

Danger of sharp metallic edges. Can cause injury. Take care when servicing unit to avoid accidental contact with sharp edges.

#### Table of Contents

Options .....	Page 2
Specifications .....	Page 5
Blower Data .....	Page 7
Electrical /Electric Heat Data ....	Page 19
Electric Heat Capacities .....	Page 26
Parts Arrangement .....	Page 28
I Unit Components .....	Page 29
II Placement and Installation .....	Page 39
III Start Up Operation .....	Page 39
IV Charging .....	Page 39
V System Service Checks .....	Page 41
VI Maintenance .....	Page 41
VII Accessories .....	Page 42
VIII Diagrams .....	Page 48

## OPTIONS / ACCESSORIES

Item	Model Number	Catalog Number	Unit			
			036	048	060	072
<b>COOLING SYSTEM</b>						
Condensate Drain Trap	PVC - C1TRAP20AD2	<b>76W26</b>	OX	OX	OX	OX
	Copper - C1TRAP10AD2	<b>76W27</b>	OX	OX	OX	OX
Drain Pan Overflow Switch	E1SNSR71AD1	<b>68W88</b>	OX	OX	OX	OX
Efficiency	Standard	Factory	O	O	O	
	High	Factory	O	O	O	O
Service valves (not for Humiditrol equipped units)		Factory	O	O	O	O
<b>BLOWER - SUPPLY AIR</b>						
Motors	Direct Drive - 0.50 hp	Factory	O			
	Direct Drive - 0.75 hp	Factory		O		
	Direct Drive - 1 hp	Factory			O	
	Belt Drive - .75 hp (2 Speed)	Factory	O	O		
	Belt Drive - 1 hp (2 Speed)	Factory	O		O	
	Belt Drive - 2 hp (2 Speed)	Factory		O	O	
	Belt Drive - 1 hp Standard Efficiency	Factory				O
	Belt Drive - 2 hp Standard Efficiency	Factory				O
	Belt Drive - 1 hp High Efficiency	Factory				O
	Belt Drive - 2 hp High Efficiency	Factory				O
Drive Kits	Kit A01 - T1DRKT001-1 - 673-1010 rpm	Factory	O			
See Blower Data Tables for selection	Kit A02 - T1DRKT002-1 - 745-1117 rpm	Factory		O		
	Kit A03 - T1DRKT003-1 - 833-1250 rpm	Factory			O	
	Kit A05 - T1DRKT005-1 - 897-1346 rpm	Factory	O			
	Kit A06 - T1DRKT006-1 - 1071-1429 rpm	Factory		O		
	Kit A07 - T1DRKT007-1 - 1212-1548 rpm	Factory			O	
	Kit AA01 - T1DRKT001AP1 - 522-784 rpm	Factory				O
	Kit AA02 - T1DRKT002AP1 - 632-875 rpm	Factory				O
	Kit AA03 - T1DRKT003AP1 - 798-1105 rpm	Factory				O
	Blower Belt Auto-Tensioner	Factory	O	O	O	O
<b>CABINET</b>						
Coil Guards	T1GARD20A-1	<b>17W87</b>	X	X		
	T1GARD20N-1	<b>17W88</b>			X	X
Hail Guards	T1GARD10A-1	<b>17W89</b>	X	X		
	T1GARD10N-1	<b>17W90</b>			X	X
Corrosion Protection (indoor coil / outdoor coil)		Factory	O	O	O	O
<b>CONTROLS</b>						
Blower Proving Switch	C1SNSR35FF1	<b>53W65</b>	OX	OX	OX	OX
Commercial Controls	L Connection® Building Automation System	Factory	X	X	X	X
	Prodigy™ Control System - BACnet® Module - C0CTRL60AE1L	<b>59W51</b>	OX	OX	OX	OX
	Prodigy™ Control System - LonTalk® Module - C0CTRL65AE1L	Factory	O	O	O	O
	Novar® 2051 - E0CTRL30A1	<b>64W72</b>	OX	OX	OX	OX
	Novar® LSM	Factory	O	O	O	O
Dirty Filter Switch	E1SNSR55AP1	<b>53W66</b>	OX	OX	OX	OX
Fresh Air Tempering	C1SNSR75AD1	<b>58W63</b>	OX	OX	OX	OX
Smoke Detector - Supply or Return (Power board and one sensor)	C1SNSR44AP1	<b>53W78</b>	OX	OX	OX	OX
Smoke Detector - Supply and Return (Power board and two sensors)	C1SNSR43AP1	<b>53W79</b>	OX	OX	OX	OX
<b>ELECTRICAL</b>						
Voltage	208/230V - 1 phase	Factory	<sup>1</sup> O	<sup>1</sup> O	<sup>1</sup> O	
60 hz	208/230V - 3 phase	Factory	O	O	O	O
	460V - 3 phase	Factory	O	O	O	O
	575V - 3 phase	Factory	O	O	O	O
HACR Circuit Breakers		Factory	O	O	O	O
Disconnect Switch	80 amp - T2DISC080AH1	<b>20W21</b>	OX	OX		
(See Electrical / Electric Heat Tables for selection)	150 amp - T2DISC150AH1	<b>20W22</b>		OX		
	80 amp T2DISC080NH1	<b>20W24</b>			OX	OX
	150 amp - T2DISC150NH1	<b>20W25</b>			OX	OX
GFI Service Outlets	LTAGFIK10/15	<b>74M70</b>	OX	OX	OX	OX
Phase/Voltage Detection - 3 Phase Models Only		Factory	O	O	O	O

<sup>1</sup> 208/230-1ph not available on belt drive units

NOTE - Catalog and model numbers shown are for ordering field installed accessories.

OX = Configure To Order (Factory Installed) or Field Installed

O = Configure To Order (Factory Installed)

X = Field Installed

## OPTIONS / ACCESSORIES

Item	Model Number	Catalog Number	Unit			
			036	048	060	072
<b>ELECTRIC HEAT</b>						
7.5 kW	208/230V-1ph - E1EH0075AN1P	<b>46W28</b>	OX	OX	OX	
	208/230V-3ph - E1EH0075AN1Y	<b>46W31</b>	OX	OX	OX	OX
	460V-3ph - E1EH0075AN1G	<b>46W35</b>	OX	OX	OX	OX
	575V-3ph - E1EH0075AN1J	<b>46W39</b>	OX	OX	OX	OX
15 kW	208/230V-1ph - E1EH0150AN1P	<b>46W29</b>	OX	OX	OX	
	208/230V-3ph - E1EH0150AN1Y	<b>46W32</b>	OX	OX	OX	OX
	460V-3ph - E1EH0150AN1G	<b>46W36</b>	OX	OX	OX	OX
	575V-3ph - E1EH0150AN1J	<b>46W40</b>	OX	OX	OX	OX
22.5 kW	208/230V-1ph - E1EH0225N1P	<b>46W30</b>			OX	
	208/230V-3ph - E1EH0225N1Y	<b>46W33</b>			OX	OX
	460V-3ph - E1EH0225N1G	<b>46W37</b>			OX	OX
	575V-3ph - E1EH0225N1J	<b>46W41</b>			OX	OX
30 kW	208/230V-3ph - E1EH0300N-1Y	<b>46W34</b>				OX
	460V-3ph - E1EH0300N-1G	<b>46W38</b>				OX
	575V-3ph - E1EH0300N-1J	<b>46W42</b>				OX
<b>ECONOMIZER</b>						
<b>Economizer With Outdoor Air Hood (Sensible Control)</b>						
Economizer - With Barometric Relief Dampers and Exhaust Hood		Factory	O	O	O	O
Economizer - With Power Exhaust Fan and Barometric Relief Dampers with Exhaust Hood		Factory	O	O	O	O
Economizer - No Exhaust Option		Factory	O	O	O	O
Economizer - With Barometric Relief Damper with Hood		E1ECON30A-1- E1ECON30AT1-	<b>53W33</b> <b>53W36</b>	X X		X X
Horizontal Economizer Conversion Kit		T1HECK00AN1	<b>17W45</b>	X	X	X
<b>Economizer Controls</b>						
Differential Enthalpy		Order 2 - C1SNSR64FF1	<b>53W64</b>	OX	OX	OX
Sensible Control		Sensor is Furnished	Factory	O	O	O
Single Enthalpy		C1SNSR64FF1	<b>53W64</b>	OX	OX	OX
Global Control		Sensor Field Provided	Factory	O	O	O
<b>OUTDOOR AIR</b>						
<b>Outdoor Air Dampers</b>						
Damper Section - Manual, Includes Outdoor Air Hood		E1DAMP11A-1- E1DAMP11AT1-	<b>53W34</b> <b>53W37</b>	OX OX	OX OX	
Damper Section - Motorized, Includes Outdoor Air Hood		E1DAMP21A-1- E1DAMP21AT1-	<b>53W35</b> <b>53W38</b>	OX OX	OX OX	
<b>POWER EXHAUST FAN (DOWNFLOW ONLY)</b>						
Standard Static		208/230V-1 or 3ph - E1PWRE10A-1P	<b>53W27</b>	OX	OX	
<i>Note - Includes Barometric Relief Dampers and Exhaust Hood when factory installed. Order Barometric Relief Dampers and Exhaust Hood below when field installed.</i>		460V-3ph - E1PWRE10A-1G	<b>53W28</b>	OX	OX	
		575V-3ph - E1PWRE10A-1J	<b>53W29</b>	OX	OX	
		208/230V-1 or 3ph - E1PWRE10AT1P	<b>53W30</b>			OX
		460V-3ph - E1PWRE10AT1G	<b>53W31</b>			OX
		575V-3ph - E1PWRE10AT1J	<b>53W32</b>			OX
<b><sup>1</sup> BAROMETRIC RELIEF</b>						
Barometric Relief Dampers with Exhaust Hood		C1DAMP50A-1- C1DAMP50AT1-	<b>74W38</b> <b>74W39</b>	X X	X X	X X
<b>HUMIDITROL® CONDENSER REHEAT OPTION</b>						
Humiditrol			Factory	O	O	O
Humidity Sensor Kit, Remote mounted (required)		COSNSR31AE-1	<b>17M50</b>	X	X	X

<sup>1</sup> Required when Economizer is factory installed (no exhaust option) with field installed Power Exhaust Fan option.

NOTE - Catalog and model numbers shown are for ordering field installed accessories.

OX - Configure To Order (Factory Installed) or Field Installed

O = Configure To Order (Factory Installed)

X = Field Installed

## OPTIONS / ACCESSORIES

Item	Model Number	Catalog Number	Unit			
			036	048	060	072
<b>INDOOR AIR QUALITY</b>						
<b>Air Filters</b>						
Healthy Climate® High Efficiency Air Filters Order 4 per unit	MERV 8 (16 x 20 x 2) - C1FLTR15A-1-	<b>54W20</b>	OX	OX		
	MERV 13 (16 x 20 x 2) - T1FLTR40A-1-	<b>52W37</b>	OX	OX		
	MERV 8 (20 x 20 x 2) - C1FLTR15D-1-	<b>54W21</b>			OX	OX
	MERV 13 (20 x 20 x 2) - C1FLTR40D-1-	<b>52W39</b>			OX	OX
Replaceable Media Filter With Metal Mesh Frame (includes non-pleated filter media)	16 x 20 x 2 (Order 4) - K1FLTR30A-1	<b>39W09</b>	X	X		
	20 x 20 x 2 (Order 4) - K1FLTR30A-2	<b>44N60</b>			X	X
<b>Indoor Air Quality (CO<sub>2</sub>) Sensors</b>						
Sensor - Wall-mount, off-white plastic cover with LCD display	C0SNSR50AE1L	<b>77N39</b>	X	X	X	X
Sensor - Wall-mount, off-white plastic cover, no display	C0SNSR52AE1L	<b>87N53</b>	X	X	X	X
Sensor - Black plastic case with LCD display, rated for plenum mounting	C0SNSR51AE1L	<b>87N52</b>	X	X	X	X
Sensor - Wall-mount, black plastic case, no display, rated for plenum mounting	C0MISC19AE1	<b>87N54</b>	X	X	X	X
CO <sub>2</sub> Sensor Duct Mounting Kit - for downflow applications	C0MISC19AE1-	<b>85L43</b>	X	X	X	X
Aspiration Box - for duct mounting non-plenum rated CO <sub>2</sub> sensors (87N53 or 77N39)	C0MISC16AE1-	<b>90N43</b>	X	X	X	X
<b>UVC Germicidal Lamps</b>						
<sup>1</sup> Healthy Climate® UVC Light Kit (208/230v-1ph)	C1UVCL10AN1-	<b>50W90</b>	OX	OX	OX	OX
<b>ROOF CURBS - DOWNFLOW</b>						
<b>Clip Curb</b>						
8 in. height	T1CURB23AN1	<b>16W93</b>	X	X	X	X
14 in. height	T1CURB20AN1	<b>16W94</b>	X	X	X	X
18 in. height	T1CURB21AN1	<b>16W95</b>	X	X	X	X
24 in. height	T1CURB22AN1	<b>16W96</b>	X	X	X	X
<b>Hinged</b>						
8 in. height	T1CURB30AN1	<b>17W46</b>	X	X	X	X
18 in. height	T1CURB32AN1	<b>17W47</b>	X	X	X	X
24 in. height	T1CURB33AN1	<b>17W48</b>	X	X	X	X
<b>Standard</b>						
14 in. height	T1CURB10AN1	<b>13W27</b>	X	X	X	X
<b>Adjustable Pitched Curb</b>						
14 in. height	C1CURB55AT1	<b>43W27</b>	X	X	X	X
<b>Transition Curb</b>						
Matches Emergence® 036-072 Units to existing L Series® Curbs	E1CURB60A-1	<b>20W06</b>	X	X	X	X
<b>CEILING DIFFUSERS</b>						
Step-Down - Order one	RTD9-65-R	<b>27G87</b>	X	X	X	
	RTD11-95	<b>29G04</b>				X
	(Canada Only) RTD11-95S	<b>13K61</b>				X
Flush - Order one	FD9-65-R	<b>27G86</b>	X	X	X	
	FD11-95	<b>29G08</b>				X
	(Canada Only) FD11-95S	<b>13K56</b>				X
Transitions (Supply and Return) - Order one	T1TRAN10AN1	<b>17W53</b>	X	X	X	
	T1TRAN20N-1	<b>17W54</b>				X

<sup>1</sup> Lamps operate on 110-230V single-phase power supply. Step-down transformer may be ordered separately for 460V and 575V units. Alternately, 110V power supply may be used to directly power the UVC ballast(s)

NOTE - Catalog and model numbers shown are for ordering field installed accessories.

OX - Configure To Order (Factory Installed) or Field Installed

O = Configure To Order (Factory Installed)

X = Field Installed

## SPECIFICATIONS - DIRECT DRIVE

General Data		Nominal Tonnage	3 Ton	4 Ton	5 Ton
		Model Number	LCH036H4E	LCH048H4E	LCH060H4E
		Efficiency Type	High	High	High
		Blower Type	Multi-Speed Direct Drive	Multi-Speed Direct Drive	Multi-Speed Direct Drive
<b>Cooling Performance</b>	Gross Cooling Capacity - Btuh		35,800	50,100	61,600
	<sup>1</sup> Net Cooling Capacity - Btuh		35,200	49,000	60,000
	AHRI Rated Air Flow - cfm		1200	1600	1750
	Total Unit Power - kW		2.8	3.8	4.7
	<sup>2</sup> SEER (Btuh/Watt)		17.0	17.0	17.0
	<sup>1</sup> EER (Btuh/Watt)		12.5	12.8	12.7
	Refrigerant Type		R-410A	R-410A	R-410A
	Refrigerant Charge Furnished		9 lbs. 1 oz.	11 lbs. 5 oz.	15 lbs. 8 oz.
	Refrigerant Charge Furnished with Humiditrol® Option		9 lbs. 12 oz.	12 lbs. 7 oz.	17 lbs. 8 oz.
<b>Electric Heat Available - See Page 20 - Page 26</b>			7.5 and 15 kW	7.5 and 15 kW	7.5, 15 and 22.5 kW
<b>Compressor Type (number)</b>			Scroll (1)	Scroll (1)	Scroll (1)
<b>Outdoor Coils</b>	Net face area (total) - sq. ft.		15.60	15.60	19.30
	Tube diameter - in.		3/8	3/8	3/8
	Number of rows		1.5	2	2
	Fins per inch		20	20	20
<b>Outdoor Coil Fans</b>	Motor - (No.) horsepower		(1) 1/3 (ECM)	(1) 1/3 (ECM)	(1) 1/3 (ECM)
	Motor rpm		715-810	645-810	930-1100
	Total Motor Input - watts		112-160	89-165	230-350
	Diameter - (No.) in.		(1) 24	(1) 24	(1) 24
	Number of blades		3	3	3
	Total air volume - cfm		3400-3795	2910-3675	4315-4980
<b>Indoor Coils</b>	Net face area (total) - sq. ft.		7.78	7.78	9.72
	Tube diameter - in.		3/8	3/8	3/8
	Number of rows		3	4	4
	Fins per inch		14	14	14
	Drain connection (Number) and size - in.		(1) 1 NPT	(1) 1 NPT	(1) 1 NPT
	Expansion device type		Balance port TXV, removable head		
<sup>2</sup> <b>Indoor Blower</b>	Nominal motor HP		0.50 (ECM)	0.75 (ECM)	1 (ECM)
	Blower wheel nominal diameter x width - in.		(1) 10 X 10	(1) 10 X 10	(1) 11 X 10
<b>Filters</b>	Type of filter		disposable		
	Number and size - in.		(4) 16 X 20 X 2		(4) 20 x 20 x 2
<b>Electrical characteristics</b>			208/230V - 60 hz - 1 phase 208/230V, 460V, or 575V - 60 hz -3 phase		

NOTE - Net capacity includes evaporator blower motor heat deduction. Gross capacity does not include evaporator blower motor heat deduction.

<sup>1</sup> Certified in accordance with the ULE certification program, which is based on AHRI Standard 210/240; 95°F outdoor air temperature and 80°F db/67°F wb entering evaporator air; minimum external duct static pressure.

<sup>2</sup> Using total air volume and system static pressure requirements determine from blower performance tables rpm and motor output required. Maximum usable output of motors furnished are shown. In Canada, nominal motor output is also maximum usable motor output. If motors of comparable output are used, be sure to keep within the service factor limitations outlined on the motor nameplate.

## SPECIFICATIONS - BELT DRIVE

General Data		Nominal Tonnage	3 Ton	4 Ton	5 Ton	6 Ton	
		Model Number	LCH036S4T	LCH048S4T	LCH060S4T	LCH072H4B	
		Efficiency Type	Standard	Standard	Standard	High	
		Blower Type	Two Speed Belt Drive	Two Speed Belt Drive	Two Speed Belt Drive	Single Speed Belt Drive	
<b>Cooling Performance</b>	Gross Cooling Capacity - Btuh		35,800	50,100	61,600	73,500	
	<sup>1</sup> Net Cooling Capacity - Btuh		34,800	49,000	60,000	<sup>2</sup> 72,000	
	AHRI Rated Air Flow - cfm		1200	1600	1750	1920	
	Total Unit Power - kW		3.0	4.1	4.8	6.0	
	<sup>1</sup> SEER (Btuh/Watt)		15.0	15.0	15.5	---	
	<sup>3</sup> IEER (Btuh/Watt)		---	---	---	13.5	
	<sup>1</sup> EER (Btuh/Watt)		11.6	12.5	12.5	<sup>2</sup> 12.0	
	Refrigerant Type		R-410A	R-410A	R-410A	R-410A	
	Refrigerant Charge Furnished		9 lbs. 1 oz.	11 lbs. 5 oz.	15 lbs. 8 oz.	16 lbs. 5 oz.	
Refrigerant Charge Furnished with Humiditrol® Option		9 lbs. 12 oz.	12 lbs. 7 oz.	17 lbs. 8 oz.	16 lbs. 5 oz.		
<b>Electric Heat Available - See Page 20 - Page 26</b>			7.5 and 15 kW	7.5 and 15 kW	7.5, 15 and 22.5 kW	7.5, 15, 22.5 and 30 kW	
<b>Compressor Type (number)</b>			Scroll (1)	Scroll (1)	Scroll (1)	Scroll (1)	
<b>Outdoor Coils</b>	Net face area (total) - sq. ft.		15.60	15.60	19.30	19.30	
	Tube diameter - in.		3/8	3/8	3/8	3/8	
	Number of rows		1.5	2	2	2	
	Fins per inch		20	20	20	20	
<b>Outdoor Coil Fans</b>	Motor - (No.) horsepower		(1) 1/10 (PSC)	(1) 1/4 (PSC)	(1) 1/3 (PSC)	(1) 1/3 (PSC)	
	Motor rpm		825	825	1075	1075	
	Total Motor Input - watts		168	230	410	410	
	Diameter - (No.) in.		(1) 24	(1) 24	(1) 24	(1) 24	
	Number of blades		3	3	3	3	
	Total air volume - cfm		3,000	3,300	4,800	4,800	
<b>Indoor Coils</b>	Net face area (total) - sq. ft.		7.78	7.78	9.72	9.72	
	Tube diameter - in.		3/8	3/8	3/8	3/8	
	Number of rows		3	4	4	4	
	Fins per inch		14	14	14	14	
	Drain connection (Number) and size - in.		(1) 1 NPT	(1) 1 NPT	(1) 1 NPT	(1) 1 NPT	
	Expansion device type		Balance port TXV, removable head				
<b><sup>4</sup> Indoor Blower and Drive Selection</b>	No. of Speeds		2	2	2	1	
	Nominal motor HP	Low static	0.75	0.75	1	1	
		High static	1	2	2	2	
	Maximum usable motor output (US Only)	Low static	0.86	0.86	1.15	1.15	
		High static	1.15	2.3	2.3	2.30	
	Motor - Drive kit number	A01		A02		A03	AA01
		low 449-673 high 673-1010		low 497-673 high 745-1117		low 555-833 high 833-1250	522 - 784 rpm AA02
A05			A06		A07	632 - 875 rpm AA03	
low 598-897 high 897-1346			low 714-953 high 1071-1429		low 808-1032 high 1212-1548	798 - 1105 rpm	
Blower wheel nominal diameter x width - in.		(1) 10 X 10	(1) 10 X 10	(1) 10 X 10	(1) 15 X 9		
<b>Filters</b>	Type of filter		disposable				
	Number and size - in.		(4) 16 X 20 X 2		(4) 20 X 20 X 2		
<b>Electrical characteristics</b>			208/230V, 460V, or 575V - 60 hz -3 phase				

NOTE - Net capacity includes evaporator blower motor heat deduction. Gross capacity does not include evaporator blower motor heat deduction.

<sup>1</sup> Certified in accordance with the ULE or <sup>2</sup> USE certification program, which is based on AHRI Standard 210/240 or <sup>2</sup> 340/360; 95°F outdoor air temperature and 80°F db/67°F wb entering evaporator air; minimum external duct static pressure.

<sup>3</sup> Integrated Energy Efficiency Ratio tested according to AHRI Standard 340/360.

<sup>4</sup> Using total air volume and system static pressure requirements determine from blower performance tables rpm and motor output required. Maximum usable output of motors furnished are shown. In Canada, nominal motor output is also maximum usable motor output. If motors of comparable output are used, be sure to keep within the service factor limitations outlined on the motor nameplate.

## BLOWER DATA - DIRECT DRIVE - 3 TON

BLOWER TABLE INCLUDES RESISTANCE FOR BASE UNIT ONLY WITH DRY INDOOR COIL AND AIR FILTERS IN PLACE. FOR ALL UNITS ADD:

1 - Any factory installed options air resistance (heat section, economizer, etc.).

2 - Any field installed accessories air resistance (duct resistance, diffuser, etc.).

See Page 18 for wet coil and options/accessory air resistance data.

**NOTE - Default Speed Settings (percentage of blower torque) - Low 28% / High 55%**

### DOWNFLOW

External Static Press. in. w.g.	Percentage of Total Motor Torque																										
	20%		30%		40%		50%		60%		70%		80%		90%		100%										
	Cfm	Watts	RPM	Cfm	Watts	RPM	Cfm	Watts	RPM	Cfm	Watts	RPM	Cfm	Watts	RPM	Cfm	Watts	RPM									
0	785	38	407	969	68	468	1152	98	529	1301	140	581	1449	182	634	1571	236	683	1693	290	732	1799	352	770	1904	414	809
0.1	720	44	475	919	74	522	1117	104	569	1264	150	626	1411	195	684	1539	248	724	1667	301	765	1772	366	805	1877	431	844
0.2	645	50	550	851	83	593	1056	116	637	1218	161	680	1380	205	722	1509	259	762	1638	313	802	1744	380	840	1849	446	879
0.3	570	56	620	793	90	651	1016	124	681	1175	172	730	1334	220	779	1468	274	813	1601	328	846	1708	396	883	1815	464	920
0.4	505	60	678	731	97	712	956	135	746	1130	182	781	1303	229	815	1434	286	852	1564	342	889	1676	410	920	1787	477	951
0.5	432	65	740	663	105	775	895	145	810	1076	194	839	1257	243	867	1396	298	895	1534	353	923	1647	421	952	1759	489	981
0.6	---	---	---	---	---	---	855	152	852	1033	204	884	1211	256	917	1351	312	944	1490	369	971	1604	437	997	1718	505	1024
0.7	---	---	---	---	---	---	792	163	916	986	213	933	1180	264	949	1320	321	975	1460	379	1002	1575	447	1026	1690	515	1050
0.8	---	---	---	---	---	---	734	173	975	934	224	985	1134	275	995	1275	334	1021	1416	393	1046	1533	460	1067	1649	527	1088
0.9	---	---	---	---	---	---	674	183	1034	881	234	1037	1088	286	1039	1230	346	1064	1371	406	1088	1490	471	1106	1608	537	1123
1.0	---	---	---	---	---	---	613	193	1095	820	246	1094	1026	300	1093	1184	357	1104	1342	414	1115	1448	480	1140	1553	547	1165
1.1	---	---	---	---	---	---	---	---	---	---	---	---	980	309	1131	1139	367	1142	1297	425	1154	1404	488	1173	1511	551	1192
1.2	---	---	---	---	---	---	---	---	---	---	---	---	---	---	---	---	---	---	1253	436	1190	1355	495	1207	1456	554	1225

### HORIZONTAL

External Static Press. in. w.g.	Percentage of Total Motor Torque																										
	20%		30%		40%		50%		60%		70%		80%		90%		100%										
	Cfm	Watts	RPM	Cfm	Watts	RPM	Cfm	Watts	RPM	Cfm	Watts	RPM	Cfm	Watts	RPM	Cfm	Watts	RPM									
0	796	43	372	975	64	447	1155	85	524	1302	126	560	1448	168	597	1566	214	639	1684	260	680	1786	323	720	1888	386	761
0.1	709	50	461	909	75	512	1110	101	564	1254	143	613	1398	185	662	1523	231	695	1649	277	729	1754	344	769	1858	411	810
0.2	617	57	553	828	88	591	1040	118	629	1204	156	664	1368	194	698	1492	243	734	1616	291	771	1721	358	808	1826	424	845
0.3	503	64	662	747	97	668	992	131	676	1151	172	722	1310	212	768	1442	260	794	1574	308	820	1681	374	853	1787	440	887
0.4	419	69	747	671	107	746	924	146	747	1095	185	782	1266	225	818	1398	275	844	1530	325	870	1640	389	899	1749	454	927
0.5	323	75	843	589	117	832	857	159	821	1039	198	844	1221	237	867	1359	287	888	1496	337	909	1598	403	941	1701	470	973
0.6	---	---	---	---	---	---	817	165	871	990	208	900	1162	252	929	1296	306	954	1431	360	979	1546	421	995	1662	481	1010
0.7	---	---	---	---	---	---	747	176	957	933	219	966	1118	262	974	1264	314	987	1410	367	1000	1523	427	1016	1636	487	1032
0.8	---	---	---	---	---	---	700	181	1026	886	226	1022	1073	271	1018	1216	327	1035	1359	383	1051	1469	442	1066	1579	501	1081
0.9	---	---	---	---	---	---	643	187	1110	829	235	1091	1015	283	1073	1161	341	1087	1307	399	1101	1409	456	1118	1510	513	1136
1.0	---	---	---	---	---	---	592	190	1197	781	241	1154	970	291	1113	1114	352	1130	1258	413	1147	1355	467	1161	1452	520	1176
1.1	---	---	---	---	---	---	---	---	---	---	---	---	915	300	1162	1067	362	1171	1219	424	1180	1312	473	1192	1405	522	1204
1.2	---	---	---	---	---	---	---	---	---	---	---	---	---	---	---	---	---	---	1168	437	1223	1248	480	1235	1329	523	1246

## BLOWER DATA - DIRECT DRIVE - 4 TON

**BLOWER TABLE INCLUDES RESISTANCE FOR BASE UNIT ONLY WITH DRY INDOOR COIL AND AIR FILTERS IN PLACE.FOR ALL UNITS ADD:**

1 - Any factory installed options air resistance (heat section, economizer, etc.).

2 - Any field installed accessories air resistance (duct resistance, diffuser, etc.).

See Page 18 for wet coil and options/accessory air resistance data.

**NOTE - Default Speed Settings (percentage of blower torque) - Low 40% / High 80%**

### DOWNFLOW

External Static Press. in. w.g.	Percentage of Total Motor Torque																										
	20%		30%		40%		50%		60%		70%		80%		90%		100%										
	Cfm	RPM	Cfm	RPM	Cfm	RPM	Cfm	RPM	Cfm	RPM	Cfm	RPM	Cfm	RPM	Cfm	RPM	Cfm	RPM	Cfm	RPM							
0	1046	77	485	1257	134	565	1468	191	646	1639	271	715	1810	351	784	1960	445	837	2109	539	890	2251	674	947	2393	810	1004
0.1	992	85	543	1211	145	619	1430	205	695	1609	285	755	1788	365	814	1937	463	870	2086	561	925	2227	691	977	2367	822	1029
0.2	926	95	612	1166	154	669	1405	214	727	1580	299	793	1755	384	859	1909	482	909	2063	581	959	2200	708	1008	2336	835	1056
0.3	883	101	657	1125	164	715	1367	227	774	1551	311	831	1734	396	888	1891	495	934	2048	593	980	2181	719	1028	2314	844	1076
0.4	818	111	724	1074	175	772	1329	240	820	1515	327	875	1701	414	930	1859	515	975	2017	617	1021	2147	737	1064	2276	857	1107
0.5	752	121	791	1022	187	828	1291	253	865	1485	339	911	1679	425	957	1837	529	1003	1994	632	1049	2120	749	1090	2245	866	1131
0.6	687	131	858	979	201	886	1202	266	908	1450	354	952	1646	442	996	1809	544	1036	1972	646	1076	2094	760	1114	2215	873	1153
0.7	622	141	925	936	215	951	1202	282	965	1408	370	999	1613	458	1034	1777	560	1071	1941	662	1109	2063	771	1141	2185	879	1174
0.8	557	151	990	897	229	1020	1164	294	1006	1372	383	1038	1580	473	1070	1745	574	1104	1910	676	1138	2025	781	1171	2139	886	1204
0.9	492	161	1059	856	243	1089	1126	306	1046	1337	396	1075	1548	487	1105	1714	587	1135	1880	687	1165	1987	788	1198	2094	889	1230
1.0	427	171	1128	815	257	1158	1081	320	1092	1298	410	1115	1515	500	1138	1675	599	1169	1834	699	1200	1941	794	1227	2048	889	1254
1.1	362	181	1197	774	271	1227	1046	334	1149	1257	424	1139	1476	514	1174	1632	609	1201	1788	704	1229	1896	795	1251	2003	886	1274
1.2	297	191	1266	733	285	1296	1007	348	1208	1316	438	1183	1435	528	1206	1681	623	1219	1728	702	1256	1835	790	1277	1942	878	1298

### HORIZONTAL

External Static Press. in. w.g.	Percentage of Total Motor Torque																										
	20%		30%		40%		50%		60%		70%		80%		90%		100%										
	Cfm	RPM	Cfm	RPM	Cfm	RPM	Cfm	RPM	Cfm	RPM	Cfm	RPM	Cfm	RPM	Cfm	RPM	Cfm	RPM	Cfm	RPM	Cfm	RPM	Cfm	RPM	Cfm	RPM	Cfm
0	1023	78	452	1234	131	536	1445	183	621	1611	251	688	1776	319	754	1910	400	800	2043	480	846	2192	613	904	2340	746	963
0.1	970	82	529	1192	137	596	1414	192	664	1586	261	722	1757	330	780	1902	427	837	2048	523	893	2189	640	942	2330	758	991
0.2	909	86	590	1146	144	647	1383	201	705	1553	275	764	1723	349	824	1876	444	873	2028	540	923	2170	659	970	2312	779	1018
0.3	829	95	675	1084	154	718	1339	213	761	1520	287	807	1701	361	853	1853	459	903	2005	557	953	2138	673	1001	2271	789	1049
0.4	772	104	734	1032	165	774	1293	226	814	1477	304	859	1661	382	904	1818	480	949	1975	579	993	2098	690	1039	2222	802	1084
0.5	688	118	818	967	178	841	1247	238	864	1439	317	902	1631	396	940	1787	498	986	1943	599	1032	2066	704	1069	2189	809	1106
0.6	623	128	887	928	192	894	1202	249	910	1400	330	944	1597	411	978	1758	512	1018	1920	613	1059	2035	715	1095	2150	817	1132
0.7	558	138	956	887	206	957	1146	265	967	1355	345	990	1565	426	1014	1727	527	1053	1889	629	1092	1997	726	1125	2105	822	1158
0.8	493	148	1025	846	220	1020	1085	280	1021	1302	362	1040	1520	443	1060	1685	544	1095	1849	646	1130	1950	737	1160	2051	828	1191
0.9	428	158	1094	805	234	1089	1029	292	1064	1255	376	1085	1481	460	1106	1643	560	1137	1805	660	1167	1898	745	1194	1991	830	1222
1.0	363	168	1163	764	248	1154	961	308	1114	1207	389	1126	1456	471	1137	1601	571	1173	1746	672	1209	1836	751	1230	1926	829	1251
1.1	298	178	1232	723	262	1229	924	320	1173	1266	403	1185	1416	488	1185	1549	581	1213	1682	675	1241	1774	750	1258	1867	824	1276
1.2	233	188	1301	682	276	1298	885	334	1230	1325	417	1206	1477	501	1206	1675	591	1244	1570	652	1268	1675	732	1286	1780	812	1305



## BLOWER DATA - DIRECT DRIVE - 5 TON

BLOWER TABLE INCLUDES RESISTANCE FOR BASE UNIT ONLY WITH DRY INDOOR COIL AND AIR FILTERS IN PLACE.FOR ALL UNITS ADD:

1 - Any factory installed options air resistance (heat section, economizer, etc.).

2 - Any field installed accessories air resistance (duct resistance, diffuser, etc.).

See Page 18 for wet coil and options/accessory air resistance data.

**NOTE - Default Speed Settings (percentage of blower torque) - Low 36% / High 59%**

### DOWNFLOW

External Static Press. in. w.g.	Percentage of Total Motor Torque																										
	20%		30%		40%		50%		60%		70%		80%		90%		100%										
	Cfm	Watts	RPM	Cfm	Watts	RPM	Cfm	Watts	RPM	Cfm	Watts	RPM	Cfm	Watts	RPM	Cfm	Watts	RPM									
0	1102	76	420	1324	143	510	1545	211	601	1740	302	667	1934	393	734	2096	519	797	2258	645	860	2396	791	910	2534	938	959
0.1	1038	85	484	1284	153	559	1529	221	633	1722	315	698	1914	410	763	2078	535	823	2242	660	882	2378	810	934	2514	960	986
0.2	975	94	546	1235	165	611	1495	236	677	1692	332	737	1888	429	798	2057	553	851	2225	677	905	2363	825	954	2501	973	1003
0.3	911	104	603	1192	175	654	1473	245	706	1672	343	763	1871	441	820	2040	566	874	2208	692	928	2348	839	974	2488	987	1020
0.4	847	114	657	1143	187	702	1439	259	747	1642	359	800	1845	458	852	2015	585	904	2185	712	956	2327	858	1000	2469	1005	1044
0.5	784	124	708	1095	198	747	1406	273	785	1613	374	835	1819	475	884	1994	600	931	2168	726	977	2309	874	1022	2450	1022	1066
0.6	---	---	---	---	---	---	1372	285	822	1583	388	868	1793	490	915	1969	617	959	2145	743	1004	2288	890	1046	2431	1037	1087
0.7	---	---	---	---	---	---	1339	297	856	1553	401	900	1767	505	944	1945	633	987	2122	760	1029	2267	906	1068	2411	1051	1108
0.8	---	---	---	---	---	---	1294	313	899	1518	416	936	1741	519	973	1920	647	1013	2099	776	1054	2246	920	1090	2392	1064	1127
0.9	---	---	---	---	---	---	1249	327	937	1478	432	974	1706	537	1010	1891	663	1043	2076	790	1077	2221	934	1113	2366	1078	1150
1.0	---	---	---	---	---	---	1193	343	980	1437	446	1008	1680	549	1036	1867	676	1067	2053	803	1098	2200	945	1132	2347	1087	1166
1.1	---	---	---	---	---	---	---	---	---	---	---	---	1649	562	1066	1834	691	1097	2019	821	1129	2164	961	1162	2308	1100	1194
1.2	---	---	---	---	---	---	---	---	---	---	---	---	---	---	---	1984	836	1157	2133	971	1184	2282	1037	1184	2282	1106	1211

### HORIZONTAL

External Static Press. in. w.g.	Percentage of Total Motor Torque																										
	20%		30%		40%		50%		60%		70%		80%		90%		100%										
	Cfm	Watts	RPM	Cfm	Watts	RPM	Cfm	Watts	RPM	Cfm	Watts	RPM	Cfm	Watts	RPM	Cfm	Watts	RPM									
0	1129	85	418	1343	146	512	1556	208	606	1740	306	679	1923	405	752	2084	530	812	2245	655	872	2377	807	927	2508	959	982
0.1	1063	88	464	1295	154	550	1527	220	635	1715	318	705	1903	417	776	2070	546	835	2237	675	895	2368	823	948	2498	972	1002
0.2	994	95	534	1234	166	607	1483	237	680	1681	335	743	1878	432	807	2046	562	863	2214	691	920	2347	842	971	2479	993	1023
0.3	917	103	606	1178	179	665	1438	255	724	1645	351	780	1852	447	836	2018	580	894	2183	712	952	2321	862	997	2459	1012	1043
0.4	862	112	681	1128	192	725	1393	272	768	1604	370	823	1814	468	878	1987	598	927	2160	728	975	2298	881	1021	2435	1034	1067
0.5	818	124	760	1091	204	779	1364	283	798	1576	383	851	1788	482	905	1963	612	951	2137	742	997	2274	898	1044	2410	1055	1090
0.6	---	---	---	---	---	---	1319	300	842	1541	398	886	1762	495	931	1934	628	979	2106	761	1026	2244	919	1071	2381	1076	1115
0.7	---	---	---	---	---	---	1274	317	885	1499	415	926	1724	513	967	1900	646	1010	2075	779	1054	2219	934	1093	2362	1089	1131
0.8	---	---	---	---	---	---	1245	328	914	1466	429	957	1686	531	1001	1865	663	1040	2044	796	1080	2188	951	1117	2332	1106	1154
0.9	---	---	---	---	---	---	1200	344	957	1424	446	995	1647	547	1032	1830	679	1069	2013	812	1105	2154	968	1143	2294	1124	1181
1.0	---	---	---	---	---	---	1155	360	1000	1382	461	1030	1609	563	1061	1796	695	1095	1983	826	1129	2124	980	1164	2264	1134	1200
1.1	---	---	---	---	---	---	---	---	---	---	---	---	1570	577	1087	1753	712	1124	1936	847	1162	2086	994	1189	2235	1141	1216
1.2	---	---	---	---	---	---	---	---	---	---	---	---	---	---	---	1905	859	1182	2041	959	1182	2282	1037	1184	2282	1106	1244

## BLOWER DATA - BELT DRIVE - 3 TON

**BLOWER TABLE INCLUDES RESISTANCE FOR BASE UNIT ONLY WITH DRY INDOOR COIL AND AIR FILTERS IN PLACE.**

FOR ALL UNITS ADD:

1 - Any factory installed options air resistance (heat section, economizer, etc.).

2 - Any field installed accessories air resistance (duct resistance, diffuser, etc.).

See Page 18 for blower motors and drives and wet coil and options/accessory air resistance data.

### DOWNFLOW

Air Volume (cfm)	External Static (in.w.g.)																			
	0.10		0.20		0.30		0.40		0.50		0.60		0.70		0.80		0.9		1.0	
	RPM	BHP	RPM	BHP	RPM	BHP	RPM	BHP	RPM	BHP	RPM	BHP	RPM	BHP	RPM	BHP	RPM	BHP	RPM	BHP
700	447	0.09	517	0.12	589	0.15	663	0.17	739	0.19	815	0.2	883	0.23	938	0.25	988	0.27	1039	0.29
800	465	0.1	534	0.14	605	0.17	678	0.19	753	0.21	825	0.23	890	0.25	946	0.27	996	0.3	1047	0.32
900	486	0.12	554	0.16	623	0.2	695	0.22	767	0.23	836	0.25	897	0.28	953	0.3	1004	0.33	1055	0.35
1000	508	0.15	576	0.19	643	0.22	713	0.24	783	0.26	848	0.28	907	0.3	961	0.33	1011	0.36	1062	0.38
1100	533	0.18	599	0.22	665	0.25	733	0.27	800	0.28	863	0.31	919	0.34	971	0.36	1020	0.39	1070	0.41
1200	560	0.21	625	0.25	689	0.28	755	0.3	820	0.32	879	0.34	932	0.37	983	0.4	1031	0.43	1079	0.45
1300	591	0.24	654	0.28	716	0.31	779	0.33	841	0.35	897	0.38	948	0.41	996	0.44	1044	0.47	1091	0.49
1400	631	0.26	690	0.3	748	0.34	807	0.36	864	0.39	916	0.42	964	0.46	1011	0.49	1058	0.51	1105	0.54

Air Volume (cfm)	External Static (in.w.g.)																			
	1.1		1.2		1.3		1.4		1.5		1.6		1.7		1.8		1.9		2.0	
	RPM	BHP	RPM	BHP	RPM	BHP	RPM	BHP	RPM	BHP	RPM	BHP	RPM	BHP	RPM	BHP	RPM	BHP	RPM	BHP
700	1088	0.31	---	---	---	---	---	---	---	---	---	---	---	---	---	---	---	---	---	---
800	1098	0.34	1144	0.36	1185	0.39	1224	0.42	---	---	---	---	---	---	---	---	---	---	---	---
900	1106	0.37	1152	0.4	1193	0.43	1232	0.46	1269	0.49	1305	0.52	1340	0.55	1376	0.59	---	---	---	---
1000	1111	0.41	1157	0.43	1199	0.47	1238	0.5	1276	0.53	1311	0.56	1347	0.6	1382	0.63	1417	0.67	1452	0.7
1100	1118	0.44	1163	0.47	1206	0.51	1245	0.54	1282	0.58	1318	0.61	1353	0.65	1388	0.68	1423	0.72	1458	0.75
1200	1127	0.48	1171	0.52	1213	0.55	1252	0.59	1289	0.62	1324	0.66	1358	0.7	1393	0.73	1428	0.77	1463	0.81
1300	1137	0.53	1181	0.56	1221	0.6	1259	0.64	1296	0.68	1330	0.71	1364	0.75	1398	0.78	1432	0.82	1467	0.86
1400	1150	0.57	1191	0.61	1231	0.65	1268	0.69	1303	0.73	1337	0.77	1371	0.8	1404	0.84	1437	0.88	1473	0.91

## BLOWER DATA - BELT DRIVE - 3 TON

**BLOWER TABLE INCLUDES RESISTANCE FOR BASE UNIT ONLY WITH DRY INDOOR COIL AND AIR FILTERS IN PLACE.**

FOR ALL UNITS ADD:

1 - Any factory installed options air resistance (heat section, economizer, etc.).

2 - Any field installed accessories air resistance (duct resistance, diffuser, etc.).

See Page 18 for blower motors and drives and wet coil and options/accessory air resistance data.

### HORIZONTAL

Air Volume (cfm)	External Static (in.w.g.)																			
	0.10		0.20		0.30		0.40		0.50		0.60		0.70		0.80		0.9		1.0	
	RPM	BHP	RPM	BHP	RPM	BHP	RPM	BHP	RPM	BHP	RPM	BHP	RPM	BHP	RPM	BHP	RPM	BHP	RPM	BHP
700	445	0.08	516	0.11	591	0.13	670	0.15	753	0.16	820	0.19	870	0.22	918	0.24	969	0.27	1021	0.29
800	463	0.09	534	0.12	608	0.14	685	0.16	766	0.18	830	0.21	878	0.24	926	0.27	977	0.29	1030	0.32
900	485	0.11	554	0.14	627	0.16	703	0.18	780	0.21	841	0.23	888	0.27	935	0.3	986	0.32	1039	0.35
1000	509	0.13	578	0.16	649	0.19	722	0.21	796	0.23	854	0.26	900	0.29	947	0.33	997	0.35	1048	0.38
1100	537	0.16	605	0.19	674	0.21	744	0.24	813	0.26	868	0.29	913	0.33	959	0.36	1008	0.39	1059	0.41
1200	567	0.19	633	0.22	700	0.24	768	0.27	833	0.3	884	0.33	928	0.37	974	0.4	1022	0.43	1071	0.45
1300	599	0.22	664	0.25	729	0.28	793	0.3	853	0.33	902	0.37	945	0.41	990	0.44	1037	0.47	1085	0.5
1400	634	0.26	697	0.29	758	0.31	819	0.34	875	0.38	921	0.42	964	0.46	1008	0.49	1054	0.52	1100	0.54

Air Volume (cfm)	External Static (in.w.g.)																			
	1.1		1.2		1.3		1.4		1.5		1.6		1.7		1.8		1.9		2.0	
	RPM	BHP	RPM	BHP	RPM	BHP	RPM	BHP	RPM	BHP	RPM	BHP	RPM	BHP	RPM	BHP	RPM	BHP	RPM	BHP
700	1071	0.32	---	---	---	---	---	---	---	---	---	---	---	---	---	---	---	---	---	---
800	1082	0.34	1128	0.37	1169	0.4	1205	0.42	---	---	---	---	---	---	---	---	---	---	---	---
900	1090	0.37	1137	0.4	1177	0.43	1214	0.46	1248	0.49	1280	0.51	1310	0.54	1340	0.57	---	---	---	---
1000	1098	0.41	1143	0.44	1184	0.47	1221	0.5	1255	0.53	1287	0.56	1318	0.59	1347	0.61	1377	0.64	1406	0.67
1100	1107	0.44	1150	0.47	1191	0.51	1228	0.54	1263	0.57	1295	0.6	1325	0.63	1355	0.66	1384	0.69	1413	0.72
1200	1117	0.48	1160	0.52	1200	0.55	1237	0.59	1271	0.62	1303	0.66	1334	0.69	1363	0.72	1392	0.75	1420	0.78
1300	1130	0.53	1171	0.57	1210	0.6	1246	0.64	1280	0.68	1312	0.71	1342	0.74	1372	0.78	1400	0.81	1429	0.84
1400	1144	0.58	1183	0.62	1221	0.66	1256	0.7	1290	0.73	1321	0.77	1352	0.8	1381	0.84	1410	0.87	1439	0.9

## BLOWER DATA - BELT DRIVE - 4 TON

**BLOWER TABLE INCLUDES RESISTANCE FOR BASE UNIT ONLY WITH DRY INDOOR COIL AND AIR FILTERS IN PLACE.**

FOR ALL UNITS ADD:

1 - Any factory installed options air resistance (heat section, economizer, etc.).

2 - Any field installed accessories air resistance (duct resistance, diffuser, etc.).

See Page 18 for blower motors and drives and wet coil and options/accessory air resistance data.

### DOWNFLOW

Air Volume (cfm)	External Static (in.w.g.)																			
	0.10		0.20		0.30		0.40		0.50		0.60		0.70		0.80		0.9		1.0	
	RPM	BHP	RPM	BHP	RPM	BHP	RPM	BHP	RPM	BHP	RPM	BHP	RPM	BHP	RPM	BHP	RPM	BHP	RPM	BHP
900	496	0.13	568	0.16	640	0.18	711	0.2	779	0.22	844	0.25	905	0.28	960	0.3	1010	0.33	1061	0.35
1000	521	0.15	592	0.18	662	0.2	731	0.23	796	0.25	858	0.28	916	0.31	969	0.34	1019	0.36	1069	0.38
1100	548	0.18	618	0.21	686	0.23	752	0.25	814	0.28	873	0.31	929	0.34	980	0.37	1029	0.39	1078	0.42
1200	577	0.21	646	0.24	712	0.26	775	0.29	834	0.31	890	0.35	943	0.38	993	0.41	1041	0.43	1089	0.46
1300	611	0.24	677	0.27	740	0.3	800	0.32	856	0.35	909	0.39	959	0.42	1007	0.45	1055	0.47	1102	0.5
1400	654	0.26	713	0.29	771	0.33	826	0.36	878	0.39	928	0.43	976	0.47	1023	0.49	1070	0.52	1117	0.55
1500	698	0.28	751	0.32	802	0.36	852	0.4	901	0.44	948	0.48	995	0.51	1041	0.54	1088	0.57	1133	0.6
1600	738	0.32	785	0.36	831	0.41	878	0.45	923	0.49	969	0.53	1014	0.57	1061	0.59	1107	0.62	1151	0.66
1700	773	0.36	816	0.41	859	0.46	903	0.51	947	0.55	991	0.58	1036	0.62	1082	0.65	1128	0.68	1169	0.72
1800	803	0.42	844	0.47	886	0.52	929	0.57	972	0.61	1016	0.64	1060	0.68	1106	0.71	1150	0.74	1189	0.79
1900	831	0.48	872	0.54	915	0.59	957	0.63	1000	0.67	1043	0.71	1087	0.74	1131	0.78	1173	0.81	1208	0.86

Air Volume (cfm)	External Static (in.w.g.)																			
	1.1		1.2		1.3		1.4		1.5		1.6		1.7		1.8		1.9		2.0	
	RPM	BHP	RPM	BHP	RPM	BHP	RPM	BHP	RPM	BHP	RPM	BHP	RPM	BHP	RPM	BHP	RPM	BHP	RPM	BHP
900	1112	0.38	1157	0.4	1198	0.43	1236	0.46	1273	0.49	1309	0.52	1344	0.56	1380	0.59	---	---	---	---
1000	1119	0.41	1164	0.44	1206	0.47	1244	0.5	1281	0.54	1317	0.57	1352	0.6	1387	0.64	1422	0.67	1458	0.71
1100	1126	0.45	1171	0.48	1213	0.51	1252	0.55	1288	0.58	1324	0.62	1359	0.65	1394	0.69	1429	0.72	1464	0.76
1200	1136	0.49	1180	0.52	1221	0.56	1259	0.6	1296	0.63	1331	0.67	1365	0.7	1400	0.74	1435	0.78	1471	0.81
1300	1148	0.53	1190	0.57	1230	0.61	1268	0.65	1304	0.68	1338	0.72	1372	0.76	1406	0.79	1440	0.83	1476	0.87
1400	1161	0.58	1202	0.62	1240	0.66	1277	0.7	1312	0.74	1346	0.78	1379	0.81	1412	0.85	1446	0.89	1482	0.92
1500	1175	0.64	1214	0.68	1252	0.72	1287	0.76	1321	0.8	1355	0.83	1387	0.87	1420	0.91	1454	0.95	1490	0.99
1600	1190	0.7	1228	0.74	1264	0.78	1298	0.82	1332	0.86	1364	0.9	1397	0.93	1430	0.97	1464	1.01	1499	1.06
1700	1206	0.76	1242	0.8	1277	0.84	1310	0.88	1343	0.92	1375	0.96	1407	1	1440	1.04	1475	1.09	1510	1.13
1800	1223	0.83	1257	0.87	1291	0.91	1324	0.95	1356	0.99	1388	1.03	1420	1.08	1453	1.12	1487	1.16	1523	1.21
1900	1240	0.91	1273	0.95	1306	0.99	1338	1.03	1369	1.07	1401	1.12	1433	1.16	1467	1.2	1501	1.25	1537	1.29

## BLOWER DATA - BELT DRIVE - 4 TON

**BLOWER TABLE INCLUDES RESISTANCE FOR BASE UNIT ONLY WITH DRY INDOOR COIL AND AIR FILTERS IN PLACE.**

FOR ALL UNITS ADD:

1 - Any factory installed options air resistance (heat section, economizer, etc.).

2 - Any field installed accessories air resistance (duct resistance, diffuser, etc.).

See Page 18 for blower motors and drives and wet coil and options/accessory air resistance data.

### HORIZONTAL

Air Volume (cfm)	External Static (in.w.g.)																			
	0.10		0.20		0.30		0.40		0.50		0.60		0.70		0.80		0.9		1.0	
	RPM	BHP	RPM	BHP	RPM	BHP	RPM	BHP	RPM	BHP	RPM	BHP	RPM	BHP	RPM	BHP	RPM	BHP	RPM	BHP
900	493	0.12	564	0.14	637	0.17	712	0.19	788	0.21	847	0.24	894	0.27	942	0.3	993	0.33	1046	0.35
1000	520	0.14	589	0.17	660	0.19	733	0.21	805	0.24	861	0.27	907	0.3	954	0.33	1004	0.36	1056	0.38
1100	549	0.16	617	0.19	686	0.22	756	0.24	823	0.27	876	0.3	921	0.33	968	0.37	1017	0.39	1067	0.42
1200	582	0.19	648	0.22	714	0.25	781	0.27	843	0.3	893	0.34	938	0.37	984	0.41	1032	0.43	1081	0.46
1300	624	0.22	686	0.25	747	0.28	808	0.31	865	0.34	912	0.38	956	0.42	1001	0.45	1048	0.48	1096	0.5
1400	670	0.24	726	0.27	782	0.31	837	0.35	887	0.39	932	0.43	975	0.47	1020	0.5	1066	0.52	1112	0.55
1500	714	0.26	765	0.31	814	0.35	863	0.39	910	0.44	953	0.48	996	0.52	1041	0.55	1086	0.58	1130	0.61
1600	752	0.3	798	0.35	844	0.4	889	0.45	933	0.49	975	0.53	1018	0.57	1062	0.6	1107	0.63	1149	0.67
1700	785	0.35	827	0.4	871	0.46	914	0.51	957	0.55	999	0.59	1042	0.63	1085	0.66	1129	0.69	1169	0.73
1800	813	0.42	855	0.47	898	0.52	940	0.57	983	0.62	1025	0.66	1067	0.69	1110	0.72	1152	0.76	1190	0.8
1900	841	0.49	883	0.54	926	0.6	969	0.65	1011	0.69	1052	0.72	1094	0.76	1136	0.79	1176	0.83	1212	0.89

Air Volume (cfm)	External Static (in.w.g.)																			
	1.1		1.2		1.3		1.4		1.5		1.6		1.7		1.8		1.9		2.0	
	RPM	BHP	RPM	BHP	RPM	BHP	RPM	BHP	RPM	BHP	RPM	BHP	RPM	BHP	RPM	BHP	RPM	BHP	RPM	BHP
900	1097	0.38	1142	0.41	1182	0.43	1218	0.46	1252	0.49	1284	0.52	1314	0.55	1344	0.57	---	---	---	---
1000	1105	0.41	1149	0.44	1190	0.47	1226	0.5	1260	0.53	1292	0.56	1322	0.59	1352	0.62	1381	0.65	1410	0.68
1100	1115	0.45	1158	0.48	1198	0.51	1235	0.55	1269	0.58	1301	0.61	1331	0.64	1360	0.67	1389	0.7	1418	0.73
1200	1126	0.49	1168	0.53	1208	0.56	1244	0.6	1278	0.63	1309	0.66	1340	0.69	1369	0.72	1398	0.75	1426	0.78
1300	1140	0.54	1180	0.57	1218	0.61	1254	0.65	1287	0.68	1319	0.72	1349	0.75	1378	0.78	1407	0.81	1436	0.84
1400	1154	0.59	1193	0.63	1230	0.67	1265	0.7	1298	0.74	1330	0.78	1360	0.81	1389	0.85	1418	0.88	1447	0.91
1500	1170	0.65	1208	0.69	1244	0.73	1278	0.77	1310	0.8	1341	0.84	1371	0.88	1401	0.91	1430	0.95	1459	0.98
1600	1187	0.71	1223	0.75	1258	0.79	1291	0.83	1323	0.87	1354	0.91	1384	0.95	1414	0.99	1443	1.02	1474	1.06
1700	1204	0.78	1240	0.82	1274	0.86	1306	0.9	1338	0.95	1369	0.99	1399	1.03	1429	1.06	1459	1.1	1490	1.14
1800	1223	0.85	1258	0.9	1291	0.94	1323	0.99	1354	1.03	1385	1.07	1415	1.11	1445	1.15	1476	1.19	1507	1.23
1900	1243	0.94	1277	0.99	1309	1.03	1341	1.08	1372	1.12	1402	1.16	1433	1.2	1464	1.24	1495	1.28	1527	1.32

## BLOWER DATA - BELT DRIVE - 5 TON

**BLOWER TABLE INCLUDES RESISTANCE FOR BASE UNIT ONLY WITH DRY INDOOR COIL AND AIR FILTERS IN PLACE.**

FOR ALL UNITS ADD:

1 - Any factory installed options air resistance (heat section, economizer, etc.).

2 - Any field installed accessories air resistance (duct resistance, diffuser, etc.).

See Page 18 for blower motors and drives and wet coil and options/accessory air resistance data.

### DOWNFLOW

Air Volume (cfm)	External Static (in.w.g.)																			
	0.10		0.20		0.30		0.40		0.50		0.60		0.70		0.80		0.9		1.0	
	RPM	BHP	RPM	BHP	RPM	BHP	RPM	BHP	RPM	BHP	RPM	BHP	RPM	BHP	RPM	BHP	RPM	BHP	RPM	BHP
1100	512	0.15	571	0.19	630	0.23	690	0.26	770	0.26	854	0.26	922	0.27	970	0.30	1006	0.35	1045	0.39
1200	535	0.18	593	0.22	651	0.26	710	0.29	788	0.30	868	0.30	933	0.31	978	0.34	1013	0.38	1053	0.42
1300	559	0.22	616	0.26	674	0.29	732	0.32	807	0.34	883	0.34	944	0.35	987	0.38	1022	0.42	1062	0.46
1400	584	0.26	641	0.29	698	0.33	755	0.36	827	0.37	899	0.38	956	0.40	997	0.43	1033	0.47	1072	0.51
1500	615	0.29	671	0.33	726	0.36	782	0.39	850	0.41	917	0.42	970	0.44	1009	0.47	1045	0.52	1085	0.56
1600	665	0.30	716	0.34	768	0.38	819	0.41	879	0.44	937	0.46	985	0.49	1022	0.52	1059	0.57	1098	0.61
1700	723	0.31	768	0.35	814	0.39	860	0.43	910	0.47	959	0.50	1001	0.54	1037	0.58	1074	0.62	1113	0.66
1800	779	0.32	818	0.37	857	0.41	897	0.46	939	0.50	980	0.55	1018	0.59	1054	0.64	1091	0.68	1129	0.72
1900	826	0.36	859	0.41	894	0.45	928	0.50	964	0.56	1000	0.61	1036	0.66	1072	0.70	1109	0.75	1146	0.79
2000	857	0.42	889	0.47	920	0.52	952	0.57	986	0.62	1020	0.68	1055	0.73	1091	0.77	1128	0.82	1164	0.86
2100	878	0.49	909	0.54	940	0.59	973	0.64	1006	0.70	1041	0.75	1076	0.80	1112	0.85	1148	0.89	1185	0.93
2200	897	0.55	929	0.61	961	0.66	994	0.72	1028	0.78	1063	0.83	1099	0.89	1134	0.93	1170	0.97	1206	1.01
2300	918	0.62	950	0.68	983	0.74	1017	0.80	1052	0.86	1087	0.92	1122	0.97	1157	1.02	1193	1.06	1228	1.09
2400	941	0.70	974	0.77	1008	0.83	1042	0.90	1077	0.96	1111	1.01	1146	1.06	1181	1.11	1216	1.15	1250	1.19

Air Volume (cfm)	External Static (in.w.g.)																			
	1.1		1.2		1.3		1.4		1.5		1.6		1.7		1.8		1.9		2.0	
	RPM	BHP	RPM	BHP	RPM	BHP	RPM	BHP	RPM	BHP	RPM	BHP	RPM	BHP	RPM	BHP	RPM	BHP	RPM	BHP
1100	1089	0.43	1134	0.46	---	---	---	---	---	---	---	---	---	---	---	---	---	---	---	---
1200	1095	0.46	1139	0.50	1186	0.53	1230	0.57	1266	0.60	---	---	---	---	---	---	---	---	---	---
1300	1104	0.50	1146	0.54	1192	0.57	1234	0.60	1269	0.64	1301	0.68	1334	0.71	1367	0.75	---	---	---	---
1400	1114	0.55	1155	0.58	1199	0.61	1240	0.65	1275	0.68	1305	0.72	1338	0.76	1372	0.80	1406	0.83	1440	0.87
1500	1125	0.60	1165	0.63	1208	0.66	1248	0.69	1281	0.73	1311	0.77	1344	0.81	1378	0.85	1412	0.89	1446	0.92
1600	1138	0.65	1177	0.68	1218	0.71	1257	0.75	1290	0.79	1319	0.83	1352	0.87	1385	0.91	1418	0.95	1452	0.98
1700	1152	0.70	1190	0.74	1231	0.77	1268	0.80	1299	0.84	1328	0.89	1360	0.93	1393	0.97	1426	1.01	1459	1.05
1800	1167	0.76	1205	0.80	1244	0.83	1280	0.87	1310	0.91	1338	0.95	1370	0.99	1402	1.04	1434	1.08	1466	1.11
1900	1183	0.82	1221	0.86	1260	0.90	1294	0.94	1323	0.98	1349	1.02	1380	1.07	1412	1.11	1443	1.15	1475	1.19
2000	1201	0.89	1239	0.93	1276	0.97	1310	1.01	1336	1.06	1362	1.10	1392	1.15	1423	1.19	1454	1.23	1485	1.27
2100	1221	0.97	1258	1.01	1294	1.05	1325	1.09	1351	1.14	1376	1.19	1406	1.23	1436	1.27	1466	1.31	1497	1.35
2200	1242	1.05	1277	1.09	1311	1.14	1341	1.18	1365	1.23	1390	1.28	1420	1.32	1450	1.36	1480	1.41	1510	1.45
2300	1262	1.14	1295	1.19	1327	1.24	1355	1.29	1380	1.33	1406	1.37	1435	1.42	1465	1.46	1494	1.50	1524	1.54
2400	1282	1.24	1313	1.30	1343	1.36	1371	1.40	1396	1.44	1423	1.48	1452	1.52	1481	1.56	1510	1.60	1540	1.64

## BLOWER DATA - BELT DRIVE - 5 TON

**BLOWER TABLE INCLUDES RESISTANCE FOR BASE UNIT ONLY WITH DRY INDOOR COIL AND AIR FILTERS IN PLACE.**

FOR ALL UNITS ADD:

1 - Any factory installed options air resistance (heat section, economizer, etc.).

2 - Any field installed accessories air resistance (duct resistance, diffuser, etc.).

See Page 18 for blower motors and drives and wet coil and options/accessory air resistance data.

### HORIZONTAL

Air Volume (cfm)	External Static (in.w.g.)																			
	0.10		0.20		0.30		0.40		0.50		0.60		0.70		0.80		0.9		1.0	
	RPM	BHP	RPM	BHP	RPM	BHP	RPM	BHP	RPM	BHP	RPM	BHP	RPM	BHP	RPM	BHP	RPM	BHP	RPM	BHP
1100	509	0.15	562	0.18	624	0.20	691	0.22	771	0.24	852	0.25	919	0.28	970	0.31	1010	0.35	1049	0.38
1200	535	0.18	589	0.21	650	0.23	715	0.25	792	0.27	869	0.29	932	0.32	980	0.35	1019	0.38	1058	0.42
1300	564	0.21	618	0.24	678	0.27	741	0.29	815	0.31	887	0.33	946	0.36	991	0.39	1030	0.43	1068	0.47
1400	604	0.24	657	0.27	715	0.30	775	0.33	842	0.35	908	0.37	962	0.40	1004	0.43	1042	0.47	1080	0.51
1500	656	0.26	706	0.30	760	0.33	814	0.36	874	0.39	931	0.41	979	0.45	1019	0.48	1056	0.53	1094	0.57
1600	712	0.29	758	0.32	807	0.36	855	0.39	906	0.43	955	0.46	997	0.50	1035	0.54	1071	0.58	1109	0.62
1700	766	0.32	808	0.36	850	0.40	892	0.44	936	0.47	978	0.51	1016	0.56	1052	0.60	1088	0.64	1126	0.68
1800	814	0.36	851	0.40	888	0.44	925	0.49	963	0.53	1000	0.57	1035	0.62	1071	0.66	1107	0.70	1143	0.74
1900	853	0.41	886	0.46	919	0.50	952	0.55	986	0.60	1021	0.64	1056	0.69	1091	0.73	1126	0.77	1163	0.81
2000	883	0.48	913	0.53	944	0.57	976	0.62	1009	0.67	1043	0.71	1078	0.76	1112	0.80	1148	0.84	1183	0.88
2100	906	0.56	936	0.60	967	0.65	999	0.70	1033	0.75	1067	0.79	1101	0.84	1135	0.88	1170	0.92	1206	0.96
2200	930	0.64	960	0.68	991	0.73	1024	0.78	1058	0.83	1092	0.88	1126	0.92	1160	0.96	1195	1.00	1230	1.04
2300	954	0.72	985	0.77	1017	0.82	1051	0.87	1085	0.92	1119	0.96	1152	1.00	1186	1.04	1220	1.08	1254	1.13
2400	981	0.81	1013	0.86	1046	0.91	1079	0.96	1113	1.00	1146	1.05	1180	1.09	1213	1.13	1245	1.18	1278	1.22

Air Volume (cfm)	External Static (in.w.g.)																			
	1.1		1.2		1.3		1.4		1.5		1.6		1.7		1.8		1.9		2.0	
	RPM	BHP	RPM	BHP	RPM	BHP	RPM	BHP	RPM	BHP	RPM	BHP	RPM	BHP	RPM	BHP	RPM	BHP	RPM	BHP
1100	1091	0.42	1134	0.45	1176	0.48	1218	0.51	1258	0.54	1297	0.57	1335	0.59	---	---	---	---	---	---
1200	1099	0.46	1141	0.49	1182	0.52	1223	0.55	1263	0.58	1302	0.61	1339	0.64	1376	0.67	1410	0.70	1444	0.72
1300	1108	0.50	1149	0.53	1190	0.56	1230	0.59	1270	0.63	1308	0.66	1345	0.70	1381	0.73	1415	0.75	1449	0.78
1400	1120	0.55	1160	0.58	1200	0.61	1240	0.65	1278	0.68	1315	0.72	1352	0.75	1387	0.78	1421	0.81	1454	0.84
1500	1133	0.60	1172	0.63	1212	0.67	1250	0.70	1288	0.74	1324	0.77	1360	0.81	1394	0.84	1428	0.87	1460	0.90
1600	1147	0.66	1186	0.69	1225	0.72	1263	0.76	1299	0.80	1334	0.83	1369	0.87	1402	0.90	1435	0.94	1467	0.96
1700	1164	0.72	1202	0.75	1240	0.78	1276	0.82	1311	0.86	1345	0.90	1379	0.93	1411	0.97	1443	1.00	1475	1.03
1800	1181	0.78	1219	0.81	1256	0.85	1291	0.89	1324	0.93	1357	0.97	1390	1.00	1421	1.04	1453	1.07	1483	1.10
1900	1200	0.85	1237	0.88	1273	0.92	1306	0.96	1339	1.00	1371	1.04	1402	1.08	1433	1.11	1463	1.15	1493	1.18
2000	1220	0.92	1257	0.96	1291	1.00	1323	1.04	1354	1.08	1385	1.12	1416	1.16	1446	1.20	1476	1.23	1505	1.26
2100	1242	1.00	1277	1.04	1310	1.08	1340	1.13	1371	1.17	1401	1.21	1431	1.25	1460	1.29	1489	1.32	1519	1.36
2200	1265	1.08	1299	1.13	1330	1.18	1359	1.23	1388	1.27	1418	1.31	1447	1.35	1476	1.39	1504	1.42	1533	1.45
2300	1288	1.17	1320	1.23	1350	1.28	1378	1.34	1406	1.38	1435	1.42	1464	1.46	1492	1.50	1521	1.53	1549	1.56
2400	1311	1.28	1341	1.33	1370	1.40	1397	1.45	1425	1.50	1454	1.54	1482	1.57	1510	1.61	1538	1.64	1567	1.67

## BLOWER DATA - BELT DRIVE - 6 TON

**BLOWER TABLE INCLUDES RESISTANCE FOR BASE UNIT ONLY WITH DRY INDOOR COIL AND AIR FILTERS IN PLACE.**

FOR ALL UNITS ADD:

1 - Any factory installed options air resistance (heat section, economizer, etc.).

2 - Any field installed accessories air resistance (duct resistance, diffuser, etc.).

See Page 18 for blower motors and drives and wet coil and options/accessory air resistance data.

### DOWNFLOW

Air Volume (cfm)	External Static (in.w.g.)																			
	0.10		0.20		0.30		0.40		0.50		0.60		0.70		0.80		0.9		1.0	
	RPM	BHP	RPM	BHP	RPM	BHP	RPM	BHP	RPM	BHP	RPM	BHP	RPM	BHP	RPM	BHP	RPM	BHP	RPM	BHP
1900	480	0.38	512	0.44	545	0.51	579	0.57	614	0.63	648	0.7	683	0.76	719	0.83	752	0.89	781	0.95
2000	493	0.43	525	0.49	558	0.56	592	0.62	626	0.68	659	0.75	693	0.81	728	0.88	759	0.94	788	1
2100	507	0.48	539	0.54	572	0.61	605	0.67	639	0.74	671	0.8	704	0.86	737	0.93	768	0.99	795	1.04
2200	522	0.53	554	0.6	587	0.66	619	0.73	652	0.79	684	0.86	716	0.92	747	0.98	777	1.04	803	1.1
2300	537	0.59	569	0.65	602	0.72	634	0.79	666	0.85	697	0.91	728	0.98	758	1.04	786	1.1	812	1.15
2400	553	0.65	585	0.71	617	0.78	649	0.85	680	0.91	711	0.98	740	1.04	769	1.1	796	1.15	821	1.21
2500	570	0.71	602	0.78	633	0.84	665	0.91	695	0.97	725	1.04	753	1.1	781	1.16	807	1.22	832	1.27
2600	588	0.77	619	0.84	650	0.91	680	0.97	710	1.04	739	1.1	767	1.16	793	1.22	818	1.28	842	1.33
2700	607	0.84	637	0.91	667	0.97	697	1.04	726	1.11	753	1.17	780	1.23	806	1.29	830	1.35	854	1.4
2800	626	0.91	655	0.97	684	1.04	713	1.11	741	1.18	768	1.24	794	1.3	819	1.36	842	1.42	866	1.47
2900	646	0.98	674	1.05	702	1.11	730	1.18	757	1.25	783	1.32	808	1.38	832	1.44	855	1.49	878	1.54

Air Volume (cfm)	External Static (in.w.g.)																			
	1.1		1.2		1.3		1.4		1.5		1.6		1.7		1.8		1.9		2.0	
	RPM	BHP	RPM	BHP	RPM	BHP	RPM	BHP	RPM	BHP	RPM	BHP	RPM	BHP	RPM	BHP	RPM	BHP	RPM	BHP
1900	807	1	832	1.04	857	1.07	883	1.11	912	1.14	941	1.17	968	1.21	993	1.25	1017	1.29	1039	1.34
2000	813	1.04	838	1.08	862	1.12	889	1.15	917	1.19	945	1.22	972	1.26	997	1.3	1020	1.35	1042	1.4
2100	820	1.09	844	1.13	869	1.17	895	1.21	923	1.24	951	1.28	977	1.32	1001	1.36	1024	1.41	1046	1.46
2200	828	1.14	852	1.18	877	1.22	903	1.26	930	1.3	957	1.33	983	1.37	1006	1.42	1028	1.47	1050	1.53
2300	836	1.2	861	1.24	885	1.28	911	1.31	938	1.35	964	1.39	989	1.43	1012	1.48	1033	1.54	1054	1.6
2400	846	1.25	870	1.29	895	1.33	920	1.37	947	1.41	972	1.45	996	1.5	1018	1.55	1039	1.61	1059	1.67
2500	856	1.31	880	1.35	905	1.39	930	1.43	956	1.47	980	1.52	1003	1.57	1024	1.63	1044	1.69	1064	1.76
2600	866	1.38	891	1.42	915	1.46	940	1.5	965	1.54	988	1.59	1010	1.65	1031	1.71	1050	1.78	1069	1.84
2700	878	1.44	902	1.48	926	1.52	950	1.57	974	1.61	997	1.67	1018	1.73	1037	1.8	1056	1.87	1075	1.93
2800	889	1.51	913	1.55	937	1.59	961	1.64	984	1.69	1006	1.75	1026	1.82	1044	1.89	1063	1.96	1081	2.03
2900	902	1.58	925	1.63	949	1.67	972	1.72	994	1.78	1015	1.84	1034	1.91	1052	1.99	1069	2.06	1087	2.13



## BLOWER DATA - BELT DRIVE - 6 TON

**BLOWER TABLE INCLUDES RESISTANCE FOR BASE UNIT ONLY WITH DRY INDOOR COIL AND AIR FILTERS IN PLACE.**

FOR ALL UNITS ADD:

1 - Any factory installed options air resistance (heat section, economizer, etc.).

2 - Any field installed accessories air resistance (duct resistance, diffuser, etc.).

See Page 18 for blower motors and drives and wet coil and options/accessory air resistance data.

### HORIZONTAL

Air Volume (cfm)	External Static (in.w.g.)																			
	0.10		0.20		0.30		0.40		0.50		0.60		0.70		0.80		0.9		1.0	
	RPM	BHP	RPM	BHP	RPM	BHP	RPM	BHP	RPM	BHP	RPM	BHP	RPM	BHP	RPM	BHP	RPM	BHP	RPM	BHP
1900	507	0.55	538	0.58	571	0.6	604	0.63	639	0.66	673	0.7	707	0.74	740	0.78	772	0.82	802	0.86
2000	522	0.59	554	0.62	586	0.64	620	0.67	653	0.71	687	0.74	720	0.78	752	0.82	783	0.87	812	0.91
2100	539	0.63	571	0.66	603	0.69	636	0.72	669	0.75	702	0.79	734	0.83	765	0.88	795	0.92	823	0.97
2200	557	0.68	588	0.71	620	0.74	652	0.77	685	0.81	717	0.84	748	0.89	778	0.93	807	0.98	834	1.03
2300	576	0.73	607	0.76	638	0.79	670	0.83	701	0.86	733	0.9	763	0.95	792	0.99	820	1.04	846	1.09
2400	596	0.79	626	0.82	657	0.85	688	0.89	718	0.92	749	0.96	778	1.01	806	1.06	833	1.11	858	1.16
2500	616	0.85	645	0.88	676	0.91	706	0.95	736	0.99	765	1.03	794	1.08	821	1.13	847	1.18	871	1.23
2600	636	0.91	665	0.94	695	0.98	724	1.02	754	1.06	782	1.1	809	1.15	836	1.2	861	1.25	885	1.3
2700	657	0.97	685	1.01	714	1.04	743	1.08	771	1.13	799	1.17	826	1.22	851	1.27	875	1.32	899	1.37
2800	677	1.03	706	1.07	734	1.11	762	1.16	790	1.2	816	1.25	842	1.3	867	1.35	890	1.4	913	1.45
2900	698	1.1	726	1.14	754	1.19	781	1.23	808	1.28	834	1.33	859	1.38	883	1.43	906	1.48	928	1.54

Air Volume (cfm)	External Static (in.w.g.)																			
	1.1		1.2		1.3		1.4		1.5		1.6		1.7		1.8		1.9		2.0	
	RPM	BHP	RPM	BHP	RPM	BHP	RPM	BHP	RPM	BHP	RPM	BHP	RPM	BHP	RPM	BHP	RPM	BHP	RPM	BHP
1900	830	0.91	857	0.95	883	0.99	910	1.04	937	1.09	964	1.13	991	1.18	1017	1.23	1042	1.28	1067	1.34
2000	839	0.96	865	1	891	1.05	917	1.09	944	1.14	970	1.19	996	1.24	1022	1.29	1047	1.34	1071	1.4
2100	849	1.02	874	1.06	900	1.11	926	1.15	952	1.2	978	1.25	1003	1.3	1028	1.35	1052	1.41	1075	1.46
2200	860	1.08	885	1.12	910	1.17	935	1.21	960	1.26	986	1.31	1010	1.36	1034	1.42	1058	1.48	1081	1.53
2300	871	1.14	895	1.19	920	1.23	945	1.28	969	1.33	994	1.38	1018	1.43	1042	1.49	1065	1.55	1087	1.61
2400	883	1.21	907	1.25	931	1.3	955	1.35	979	1.4	1003	1.45	1027	1.51	1050	1.57	1072	1.63	1094	1.69
2500	895	1.28	919	1.32	942	1.37	966	1.42	990	1.48	1013	1.53	1036	1.59	1059	1.65	1081	1.71	1102	1.78
2600	908	1.35	931	1.4	955	1.45	978	1.5	1001	1.56	1024	1.62	1046	1.68	1068	1.74	1089	1.8	1110	1.87
2700	922	1.43	945	1.48	967	1.53	990	1.59	1013	1.65	1035	1.71	1056	1.77	1078	1.84	1099	1.9	1119	1.96
2800	936	1.51	958	1.56	980	1.62	1003	1.68	1025	1.74	1046	1.8	1067	1.87	1088	1.93	1109	2	1129	2.06
2900	950	1.6	972	1.66	994	1.72	1016	1.78	1037	1.84	1058	1.91	1079	1.97	1099	2.04	1119	2.11	1139	2.17

## BLOWER DATA

### BELT DRIVE KIT SPECIFICATIONS - 036-060

Model No.	Motor HP		No. of Speeds	Drive Kits and RPM Range					
	Nominal	Maximum		A01	A02	A03	A05	A06	A07
036	0.75	0.86	2	low 449-673 high 673-1010	---	---	---	---	---
	1	1.15	2	---	---	---	low 598-897 high 897-1346	---	---
048	0.75	0.86	2	---	low 497-673 high 745-1117	---	---	---	---
	2	2.3	2	---	---	---	---	low 714-953 high 1071-1429	---
060	1	1.15	2	---	---	low 555-833 high 833-1250	---	---	---
	2	2.3	2	---	---	---	---	---	low 808-1032 high 1212-1548

### BELT DRIVE KIT SPECIFICATIONS - 072

Model No.	Motor HP		No. of Speeds	Drive Kits and RPM Range		
	Nominal	Maximum		AA01	AA02	AA03
072	1	1.15	1	522-784	---	---
	2	2.3	1	---	632-875	798-1105

### FACTORY INSTALLED OPTIONS/FIELD INSTALLED ACCESSORY AIR RESISTANCE - in. w.g.

Air Volume cfm	Wet Indoor Coil			Humiditrol Dehumidification Coil	Electric Heat	Economizer	Filters	
	036	048	060, 072				MERV 8	MERV 13

#### 036-048 MODELS

800	0.01	0.01	---	0.00	0.01	0.04	0.04	0.05
1000	0.02	0.02	---	0.00	0.03	0.04	0.04	0.07
1200	0.03	0.04	---	0.01	0.06	0.04	0.04	0.07
1400	0.04	0.05	---	0.02	0.09	0.04	0.04	0.07
1600	0.05	0.06	---	0.03	0.12	0.04	0.04	0.07
1800	0.06	0.07	---	0.04	0.15	0.05	0.04	0.07
2000	0.08	0.09	---	0.04	0.18	0.05	0.05	0.08

#### 060-072 MODELS

1000	---	---	0.02	0.00	0.01	0.04	0.03	0.05
1200	---	---	0.04	0.00	0.03	0.04	0.03	0.07
1400	---	---	0.05	0.01	0.06	0.04	0.04	0.07
1600	---	---	0.07	0.02	0.09	0.04	0.04	0.07
1800	---	---	0.08	0.02	0.12	0.05	0.05	0.07
2000	---	---	0.10	0.03	0.15	0.05	0.05	0.07
2200	---	---	0.11	0.04	0.18	0.05	0.05	0.08
2400	---	---	0.13	0.04	0.20	0.05	0.05	0.08
2600	---	---	0.15	0.05	0.22	0.06	0.05	0.08
2800	---	---	0.16	0.05	0.24	0.06	0.05	0.08
3000	---	---	0.18	0.06	0.28	0.06	0.05	0.08

### POWER EXHAUST FAN PERFORMANCE

Return Air System Static Pressure in. w.g.	Air Volume Exhausted cfm	Return Air System Static Pressure in. w.g.	Air Volume Exhausted cfm
<b>036-048 MODELS</b>		<b>060-072 MODELS</b>	
0.00	2000	0.00	3175
0.05	1990	0.05	2955
0.10	1924	0.10	2685
0.15	1810	0.15	2410
0.20	1664	0.20	2165
0.25	1507	0.25	1920
0.30	1350	0.30	1420
0.35	1210	0.35	1200

## BLOWER DATA

### CEILING DIFFUSERS AIR RESISTANCE (in. w.g.)

Air Volume cfm	RTD9-65 Step-Down Diffuser			FD9-65 Flush Diffuser	RTD11-95 Step-Down Diffuser			FD11-95 Flush Diffuser
	2 Ends Open	1 Side & 2 Ends Open	All Ends & Sides Open		2 Ends Open	1 Side & 2 Ends Open	All Ends & Sides Open	
800	0.15	0.13	0.11	0.11	---	---	---	---
1000	0.19	0.16	0.14	0.14	---	---	---	---
1200	0.25	0.20	0.17	0.17	---	---	---	---
1400	0.33	0.26	0.20	0.20	---	---	---	---
1600	0.43	0.32	0.20	0.24	---	---	---	---
1800	0.56	0.40	0.30	0.30	0.13	0.11	0.09	0.09
2000	0.73	0.50	0.36	0.36	0.15	0.13	0.11	0.10
2200	0.95	0.63	0.44	0.44	0.18	0.15	0.12	0.12
2400	---	----	---	---	0.21	0.18	0.15	0.14
2600	---	----	---	---	0.24	0.21	0.18	0.17
2800	---	----	---	---	0.27	0.24	0.21	0.20
3000	---	----	---	---	0.32	0.29	0.25	0.25

### CEILING DIFFUSER AIR THROW DATA

Air Volume - cfm	<sup>1</sup> Effective Throw - ft.	
Model No.	RTD9-65	FD9-65
800	10 - 17	14 - 18
1000	10 - 17	15 - 20
1200	11 - 18	16 - 22
1400	12 - 19	17 - 24
1600	12 - 20	18 - 25
1800	13 - 21	20 - 28
2000	14 - 23	21 - 29
2200	16 - 25	22 - 30
Model No.	RTD11-95	FD11-95
2600	24 - 29	19 - 24
2800	25 - 30	20 - 28
3000	27 - 33	21 - 29

<sup>1</sup> Effective throw based on terminal velocities of 75 ft. per minute.

**ELECTRICAL/ELECTRIC HEAT DATA****3 TON****3 TON HIGH EFFICIENCY (R-410A)****LCH036H4**

<sup>1</sup> Voltage - 60hz		208/230V - 1 Ph	208/230V - 3 Ph	460V - 3 Ph	575V - 3 Ph
Compressor	Rated Load Amps	16.7	11.2	4.5	3.7
	Locked Rotor Amps	82	58	29	22.5
Outdoor Fan Motor	Full Load Amps	4.1	4.1	2.1	1.6
Power Exhaust (1) 0.33 HP	Full Load Amps	2.4	2.4	1.3	1
Service Outlet 115V GFI (amps)		15	15	15	15
Indoor Blower Motor	Horsepower	0.5	0.5	0.5	0.5
	Full Load Amps	4.3	4.3	2.2	1.7
<sup>2</sup> Maximum Overcurrent Protection	Unit Only	45	30	15	15
	With (1) 0.33 HP Power Exhaust	45	35	15	15
<sup>3</sup> Minimum Circuit Ampacity	Unit Only	30	23	10	8
	With (1) 0.33 HP Power Exhaust	32	25	12	9

**ELECTRIC HEAT DATA**

Electric Heat Voltage		208V	240V	208V	240V	480V	600V
<sup>2</sup> Maximum Overcurrent Protection	Unit+ 7.5 kW	45	45	30	30	15	15
	Electric Heat 15 kW	<sup>4</sup> 80	90	<sup>4</sup> 45	60	30	25
<sup>3</sup> Minimum Circuit Ampacity	Unit+ 7.5 kW	40	45	25	28	15	12
	Electric Heat 15 kW	74	84	45	51	26	21
<sup>2</sup> Maximum Overcurrent Protection	Unit+ 7.5 kW	<sup>4</sup> 45	50	35	35	20	15
	Electric Heat and (1) 0.33 HP Power Exhaust 15 kW	<sup>4</sup> 80	90	<sup>4</sup> 50	60	30	25
<sup>3</sup> Minimum Circuit Ampacity	Unit+ 7.5 kW	43	48	28	31	16	13
	Electric Heat and (1) 0.33 HP Power Exhaust 15 kW	77	87	48	54	27	22

**ELECTRICAL ACCESSORIES**

Disconnect	7.5 kW	20W21	20W21	20W21	20W21	20W21	20W21
	15 kW	20W21	20W21	20W21	20W21	20W21	20W21

<sup>1</sup> Extremes of operating range are plus and minus 10% of line voltage.<sup>2</sup> HACR type breaker or fuse.<sup>3</sup> Refer to National or Canadian Electrical Code manual to determine wire, fuse and disconnect size requirements.<sup>4</sup> Factory installed circuit breaker not available.

**ELECTRICAL/ELECTRIC HEAT DATA****3 TON****3 TON STANDARD EFFICIENCY (R-410A)****LCH036S4**

<sup>1</sup> Voltage - 60hz		208/230V - 3 Ph		460V - 3 Ph		575V - 3 Ph	
Compressor	Rated Load Amps	11.2		4.5		3.7	
	Locked Rotor Amps	58		29		22.5	
Outdoor Fan Motor	Full Load Amps	0.9		0.6		0.5	
Power Exhaust (1) 0.33 HP	Full Load Amps	2.4		1.3		1	
Service Outlet 115V GFI (amps)		15		15		15	
Indoor Blower Motor	Horsepower	0.75	1	0.75	1	0.75	1
	Full Load Amps	3.5	7.5	1.6	3.4	1.3	2.7
<sup>2</sup> Maximum Overcurrent Protection	Unit Only	25	30	15	15	15	15
	With (1) 0.33 HP Power Exhaust	30	30	15	15	15	15
<sup>3</sup> Minimum Circuit Ampacity	Unit Only	19	20	8	9	7	7
	With (1) 0.33 HP Power Exhaust	21	22	10	10	8	8

**ELECTRIC HEAT DATA**

Electric Heat Voltage			208V	240V	208V	240V	480V	480V	600V	600V
<sup>2</sup> Maximum Overcurrent Protection	Unit+ 7.5 kW		<sup>4</sup> 25	30	30	30	15	15	15	15
	Electric Heat 15 kW		<sup>4</sup> 45	50	<sup>4</sup> 45	60	25	30	20	25
<sup>3</sup> Minimum Circuit Ampacity	Unit+ 7.5 kW		24	27	26	29	14	14	11	12
	Electric Heat 15 kW		44	50	45	51	25	26	20	21
<sup>2</sup> Maximum Overcurrent Protection	Unit+ 7.5 kW		30	30	<sup>4</sup> 30	35	15	20	15	15
	Electric Heat and (1) 0.33 HP Power Exhaust 15 kW		<sup>4</sup> 50	60	<sup>4</sup> 50	60	30	30	25	25
<sup>3</sup> Minimum Circuit Ampacity	Unit+ 7.5 kW		27	30	29	32	15	16	12	13
	Electric Heat and (1) 0.33 HP Power Exhaust 15 kW		47	53	48	54	27	27	21	22

**ELECTRICAL ACCESSORIES**

Disconnect	7.5 kW	20W21	20W21	20W21	20W21	20W21	20W21	20W21	20W21
	15 kW	20W21	20W21	20W21	20W21	20W21	20W21	20W21	20W21

<sup>1</sup> Extremes of operating range are plus and minus 10% of line voltage.<sup>2</sup> HACR type breaker or fuse.<sup>3</sup> Refer to National or Canadian Electrical Code manual to determine wire, fuse and disconnect size requirements.<sup>4</sup> Factory installed circuit breaker not available.

**ELECTRICAL/ELECTRIC HEAT DATA**
**4 TON**
**4 TON HIGH EFFICIENCY (R-410A)**
**LCH048H4**

<sup>1</sup> Voltage - 60hz		208/230V - 1 Ph	208/230V - 3 Ph	460V - 3 Ph	575V - 3 Ph
Compressor	Rated Load Amps	21.2	13.5	6.4	5
	Locked Rotor Amps	96	88	41	37.8
Outdoor Fan Motor	Full Load Amps	4.1	4.1	2.1	1.6
Power Exhaust (1) 0.33 HP	Full Load Amps	2.4	2.4	1.3	1
Service Outlet 115V GFI (amps)		15	15	15	15
Indoor Blower Motor	Horsepower	0.75	0.75	0.75	0.75
	Full Load Amps	6.1	6.1	3.1	2.4
<sup>2</sup> Maximum Overcurrent Protection	Unit Only	50	40	15	15
	With (1) 0.33 HP Power Exhaust	60	40	20	15
<sup>3</sup> Minimum Circuit Ampacity	Unit Only	37	28	14	11
	With (1) 0.33 HP Power Exhaust	40	30	15	12

**ELECTRIC HEAT DATA**

Electric Heat Voltage		208V	240V	208V	240V	480V	600V
<sup>2</sup> Maximum Overcurrent Protection	Unit+ 7.5 kW	50	50	<sup>4</sup> 40	40	20	15
	Electric Heat 15 kW	<sup>4</sup> 80	90	<sup>4</sup> 50	60	30	25
<sup>3</sup> Minimum Circuit Ampacity	Unit+ 7.5 kW	42	47	28	31	16	13
	Electric Heat 15 kW	76	86	47	53	27	22
<sup>2</sup> Maximum Overcurrent Protection	Unit+ 7.5 kW	60	60	40	40	20	15
	Electric Heat and (1) 0.33 HP Power Exhaust 15 kW	<sup>4</sup> 80	90	<sup>4</sup> 50	60	30	25
<sup>3</sup> Minimum Circuit Ampacity	Unit+ 7.5 kW	45	50	31	34	17	14
	Electric Heat and (1) 0.33 HP Power Exhaust 15 kW	79	89	50	56	29	23

**ELECTRICAL ACCESSORIES**

Disconnect	7.5 kW	20W21	20W21	20W21	20W21	20W21	20W21
	15 kW	20W22	20W22	20W21	20W21	20W21	20W21

<sup>1</sup> Extremes of operating range are plus and minus 10% of line voltage.

<sup>2</sup> HACR type breaker or fuse.

<sup>3</sup> Refer to National or Canadian Electrical Code manual to determine wire, fuse and disconnect size requirements.

<sup>4</sup> Factory installed circuit breaker not available.

**ELECTRICAL/ELECTRIC HEAT DATA****4 TON****4 TON STANDARD EFFICIENCY (R-410A)****LCH048S4**

<sup>1</sup> Voltage - 60hz		208/230V - 3 Ph		460V - 3 Ph		575V - 3 Ph	
Compressor	Rated Load Amps	13.5		6.4		5	
	Locked Rotor Amps	88		41		37.8	
Outdoor Fan Motor	Full Load Amps	1.7		1.1		0.7	
Power Exhaust (1) 0.33 HP	Full Load Amps	2.4		1.3		1	
Service Outlet 115V GFI (amps)		15		15		15	
Indoor Blower Motor	Horsepower	0.75	2	0.75	2	0.75	2
	Full Load Amps	3.5	7.5	1.6	3.4	1.3	2.7
<sup>2</sup> Maximum Overcurrent Protection	Unit Only	35	35	15	15	15	15
	With (1) 0.33 HP Power Exhaust	35	40	15	20	15	15
<sup>3</sup> Minimum Circuit Ampacity	Unit Only	23	27	11	13	9	10
	With (1) 0.33 HP Power Exhaust	25	29	12	14	10	11

**ELECTRIC HEAT DATA**

Electric Heat Voltage			208V	240V	208V	240V	480V	480V	600V	600V
<sup>2</sup> Maximum Overcurrent Protection	Unit+ Electric Heat	<b>7.5 kW</b>	35	35	35	35	15	20	15	15
		<b>15 kW</b>	<sup>4</sup> 45	50	<sup>4</sup> 50	60	25	30	20	25
<sup>3</sup> Minimum Circuit Ampacity	Unit+ Electric Heat	<b>7.5 kW</b>	24	27	29	32	14	16	11	13
		<b>15 kW</b>	44	50	49	55	25	27	20	22
<sup>2</sup> Maximum Overcurrent Protection	Unit+ Electric Heat and (1) 0.33 HP Power Exhaust	<b>7.5 kW</b>	35	35	40	40	15	20	15	15
		<b>15 kW</b>	<sup>4</sup> 50	60	60	60	30	30	25	25
<sup>3</sup> Minimum Circuit Ampacity	Unit+ Electric Heat and (1) 0.33 HP Power Exhaust	<b>7.5 kW</b>	27	30	32	35	15	18	12	14
		<b>15 kW</b>	47	53	52	58	27	29	21	23

**ELECTRICAL ACCESSORIES**

Disconnect	<b>7.5 kW</b>	<b>20W21</b>	<b>20W21</b>	<b>20W21</b>	<b>20W21</b>	<b>20W21</b>	<b>20W21</b>	<b>20W21</b>	<b>20W21</b>
	<b>15 kW</b>	<b>20W21</b>	<b>20W21</b>	<b>20W21</b>	<b>20W21</b>	<b>20W21</b>	<b>20W21</b>	<b>20W21</b>	<b>20W21</b>

<sup>1</sup> Extremes of operating range are plus and minus 10% of line voltage.<sup>2</sup> HACR type breaker or fuse.<sup>3</sup> Refer to National or Canadian Electrical Code manual to determine wire, fuse and disconnect size requirements.<sup>4</sup> Factory installed circuit breaker not available.

**ELECTRICAL/ELECTRIC HEAT DATA**
**5 TON**
**5 TON HIGH EFFICIENCY (R-410A)**
**LCH060H4**

<sup>1</sup> Voltage - 60hz		208/230V - 1 Ph	208/230V - 3 Ph	460V - 3 Ph	575V - 3 Ph
Compressor	Rated Load Amps	25.6	17.6	9	7.4
	Locked Rotor Amps	118	135	62	50
Outdoor Fan Motor	Full Load Amps	4.1	4.1	2.1	1.6
Power Exhaust (1) 0.33 HP	Full Load Amps	2.4	2.4	1.3	1
Service Outlet 115V GFI (amps)		15	15	15	15
Indoor Blower Motor	Horsepower	1	1	1	1
	Full Load Amps	7.4	7.4	3.7	3
<sup>2</sup> Maximum Overcurrent Protection	Unit Only	60	50	25	20
	With (1) 0.33 HP Power Exhaust	70	50	25	20
<sup>3</sup> Minimum Circuit Ampacity	Unit Only	44	34	18	14
	With (1) 0.33 HP Power Exhaust	46	36	19	15

**ELECTRIC HEAT DATA**

Electric Heat Voltage			208V	240V	208V	240V	480V	600V
<sup>2</sup> Maximum Overcurrent Protection	Unit+	7.5 kW	60	60	50	50	25	20
	Electric Heat and (1) 0.33 HP Power Exhaust	15 kW	<sup>4</sup> 80	90	<sup>4</sup> 50	60	30	25
		22.5 kW	<sup>4</sup> 125	150	<sup>4</sup> 70	80	40	35
<sup>3</sup> Minimum Circuit Ampacity	Unit+	7.5 kW	44	49	34	34	18	14
	Electric Heat and (1) 0.33 HP Power Exhaust	15 kW	77	88	49	55	28	22
		22.5 kW	111	127	68	77	39	31
<sup>2</sup> Maximum Overcurrent Protection	Unit+	7.5 kW	70	70	50	50	25	20
	Electric Heat and (1) 0.33 HP Power Exhaust	15 kW	<sup>4</sup> 80	100	60	60	30	25
		22.5 kW	<sup>4</sup> 125	150	80	80	45	35
<sup>3</sup> Minimum Circuit Ampacity	Unit+	7.5 kW	47	52	36	36	19	15
	Electric Heat and (1) 0.33 HP Power Exhaust	15 kW	80	91	52	58	29	24
		22.5 kW	114	130	71	80	41	33

**ELECTRICAL ACCESSORIES**

Disconnect	7.5 kW	20W24	20W24	20W24	20W24	20W24	20W24
	15 kW	20W25	20W25	20W24	20W24	20W24	20W24
	22.5 kW	20W25	20W25	20W24	20W24	20W24	20W24

<sup>1</sup> Extremes of operating range are plus and minus 10% of line voltage.

<sup>2</sup> HACR type breaker or fuse.

<sup>3</sup> Refer to National or Canadian Electrical Code manual to determine wire, fuse and disconnect size requirements.

<sup>4</sup> Factory installed circuit breaker not available.



**ELECTRICAL/ELECTRIC HEAT DATA****5 TON****5 TON STANDARD EFFICIENCY (R-410A)****LCH060S4**

<sup>1</sup> Voltage - 60hz		208/230V - 3 Ph		460V - 3 Ph		575V - 3 Ph	
Compressor	Rated Load Amps	17.6		9		7.4	
	Locked Rotor Amps	135		62		50	
Outdoor Fan Motor	Full Load Amps	2.4		1.3		1	
Power Exhaust (1) 0.33 HP	Full Load Amps	2.4		1.3		1	
Service Outlet 115V GFI (amps)		15		15		15	
Indoor Blower Motor	Horsepower	1	2	1	2	1	2
	Full Load Amps	4.6	7.5	2.1	3.4	1.7	2.7
<sup>2</sup> Maximum Overcurrent Protection	Unit Only	45	45	20	20	15	20
	With (1) 0.33 HP Power Exhaust	45	50	20	25	20	20
<sup>3</sup> Minimum Circuit Ampacity	Unit Only	29	32	15	16	12	13
	With (1) 0.33 HP Power Exhaust	32	35	16	18	13	14

**ELECTRIC HEAT DATA**

Electric Heat Voltage			208V	240V	208V	240V	480V	480V	600V	600V
<sup>2</sup> Maximum Overcurrent Protection	Unit+	7.5 kW	45	45	45	45	20	20	15	20
	Electric Heat and (1) 0.33 HP Power Exhaust	15 kW	<sup>4</sup> 45	60	<sup>4</sup> 50	60	30	30	25	25
		22.5 kW	<sup>4</sup> 70	80	<sup>4</sup> 70	80	40	40	30	35
<sup>3</sup> Minimum Circuit Ampacity	Unit+	7.5 kW	29	29	32	32	15	16	12	13
	Electric Heat and (1) 0.33 HP Power Exhaust	15 kW	45	51	49	55	26	27	21	22
		22.5 kW	65	74	69	78	37	39	30	31
<sup>2</sup> Maximum Overcurrent Protection	Unit+	7.5 kW	45	45	50	50	20	25	20	20
	Electric Heat and (1) 0.33 HP Power Exhaust	15 kW	<sup>4</sup> 50	60	60	60	30	30	25	25
		22.5 kW	<sup>4</sup> 70	80	<sup>4</sup> 80	90	40	40	35	35
<sup>3</sup> Minimum Circuit Ampacity	Unit+	7.5 kW	32	32	35	35	16	18	13	14
	Electric Heat and (1) 0.33 HP Power Exhaust	15 kW	48	54	52	58	27	29	22	23
		22.5 kW	68	77	72	81	39	40	31	32

**ELECTRICAL ACCESSORIES**

Disconnect	7.5 kW	20W24	20W24	20W24	20W24	20W24	20W24	20W24	20W24
	15 kW	20W24	20W24	20W24	20W24	20W24	20W24	20W24	20W24
	22.5 kW	20W24	20W24	20W24	20W24	20W24	20W24	20W24	20W24

<sup>1</sup> Extremes of operating range are plus and minus 10% of line voltage.<sup>2</sup> HACR type breaker or fuse.<sup>3</sup> Refer to National or Canadian Electrical Code manual to determine wire, fuse and disconnect size requirements.<sup>4</sup> Factory installed circuit breaker not available.

## ELECTRICAL/ELECTRIC HEAT DATA

**6 TON**

### 6 TON HIGH EFFICIENCY (R-410A)

**LCH072H4**

<sup>1</sup> Voltage - 60hz		208/230V - 3 Ph		460V - 3 Ph		575V - 3 Ph	
Compressor	Rated Load Amps	19		9.7		7.4	
	Locked Rotor Amps	123		62		50	
Outdoor Fan Motor	Full Load Amps	2.4		1.3		1	
Power Exhaust (1) 0.33 HP	Full Load Amps	2.4		1.3		1	
Service Outlet 115V GFI (amps)		15		15		15	
Indoor Blower Motor	Horsepower	1	2	1	2	1	2
	Full Load Amps	4.6	7.5	2.1	3.4	1.7	2.7
<sup>2</sup> Maximum Overcurrent Protection	Unit Only	45	50	25	25	15	20
	With (1) 0.33 HP Power Exhaust	50	50	25	25	20	20
<sup>3</sup> Minimum Circuit Ampacity	Unit Only	31	34	16	17	12	13
	With (1) 0.33 HP Power Exhaust	34	37	17	19	13	14

## ELECTRIC HEAT DATA

Electric Heat Voltage			208V	240V	208V	240V	480V	480V	600V	600V
<sup>2</sup> Maximum Overcurrent Protection	Unit+ Electric Heat	7.5 kW	45	45	50	50	25	25	15	20
		15 kW	<sup>4</sup> 45	60	<sup>4</sup> 50	60	30	30	25	25
		22.5 kW	<sup>4</sup> 70	80	<sup>4</sup> 70	80	40	40	30	35
		30 kW	<sup>4</sup> 90	100	<sup>4</sup> 90	100	50	50	40	40
<sup>3</sup> Minimum Circuit Ampacity	Unit+ Electric Heat	7.5 kW	31	31	34	34	16	17	12	13
		15 kW	45	51	49	55	26	27	21	22
		22.5 kW	65	74	69	78	37	39	30	31
		30 kW	84	96	88	100	48	50	39	40
<sup>2</sup> Maximum Overcurrent Protection	Unit+ Electric Heat and (1) 0.33 HP Power Exhaust	7.5 kW	50	50	50	50	25	25	20	20
		15 kW	<sup>4</sup> 50	60	60	60	30	30	25	25
		22.5 kW	<sup>4</sup> 70	80	<sup>4</sup> 80	90	40	40	35	35
		30 kW	<sup>4</sup> 90	100	<sup>4</sup> 100	110	50	60	40	45
<sup>3</sup> Minimum Circuit Ampacity	Unit+ Electric Heat and (1) 0.33 HP Power Exhaust	7.5 kW	34	34	37	37	17	19	13	14
		15 kW	48	54	52	58	27	29	22	23
		22.5 kW	68	77	72	81	39	40	31	32
		30 kW	87	99	91	103	50	51	40	41

## ELECTRICAL ACCESSORIES

Disconnect	7.5 kW	20W24	20W24	20W24	20W24	20W24	20W24	20W24	20W24
	15 kW	20W24	20W24	20W24	20W24	20W24	20W24	20W24	20W24
	22.5 kW	20W24	20W24	20W24	20W24	20W24	20W24	20W24	20W24
	30 kW	20W25	20W25	20W25	20W24	20W24	20W24	20W24	20W24

<sup>1</sup> Extremes of operating range are plus and minus 10% of line voltage.

<sup>2</sup> HACR type breaker or fuse.

<sup>3</sup> Refer to National or Canadian Electrical Code manual to determine wire, fuse and disconnect size requirements.

<sup>4</sup> Factory installed circuit breaker not available.

## ELECTRIC HEAT CAPACITIES

Input Voltage	7.5 kW			15 kW			22.5 kW			30 kW		
	No of Stages	kW input	Btuh Output	No of Stages	kW input	Btuh Output	No of Stages	kW input	Btuh Output	No of Stages	kW input	Btuh Output
208	1	5.6	19,200	1	11.2	38,200	1	16.9	57,700	1	22.5	76,800
220	1	6.3	21,500	1	12.6	43,000	1	18.9	64,500	1	25.2	86,000
230	1	6.9	23,500	1	13.8	47,000	1	20.7	70,700	1	27.5	93,900
240	1	7.5	25,600	1	15	51,200	1	22.5	76,800	1	30	102,400
440	1	6.3	21,500	1	12.6	43,000	1	18.9	64,500	1	25.2	86,000
460	1	6.9	23,500	1	13.8	47,000	1	20.7	70,700	1	27.5	93,900
480	1	7.5	25,600	1	15	51,200	1	22.5	76,800	1	30	102,400
550	1	6.3	21,500	1	12.6	43,000	1	18.9	64,500	1	25.2	86,000
575	1	6.9	23,500	1	13.8	47,000	1	20.7	70,700	1	27.5	93,900
600	1	7.5	25,600	1	15	51,200	1	22.5	76,800	1	30	102,400

## LCH PARTS ARRANGEMENT

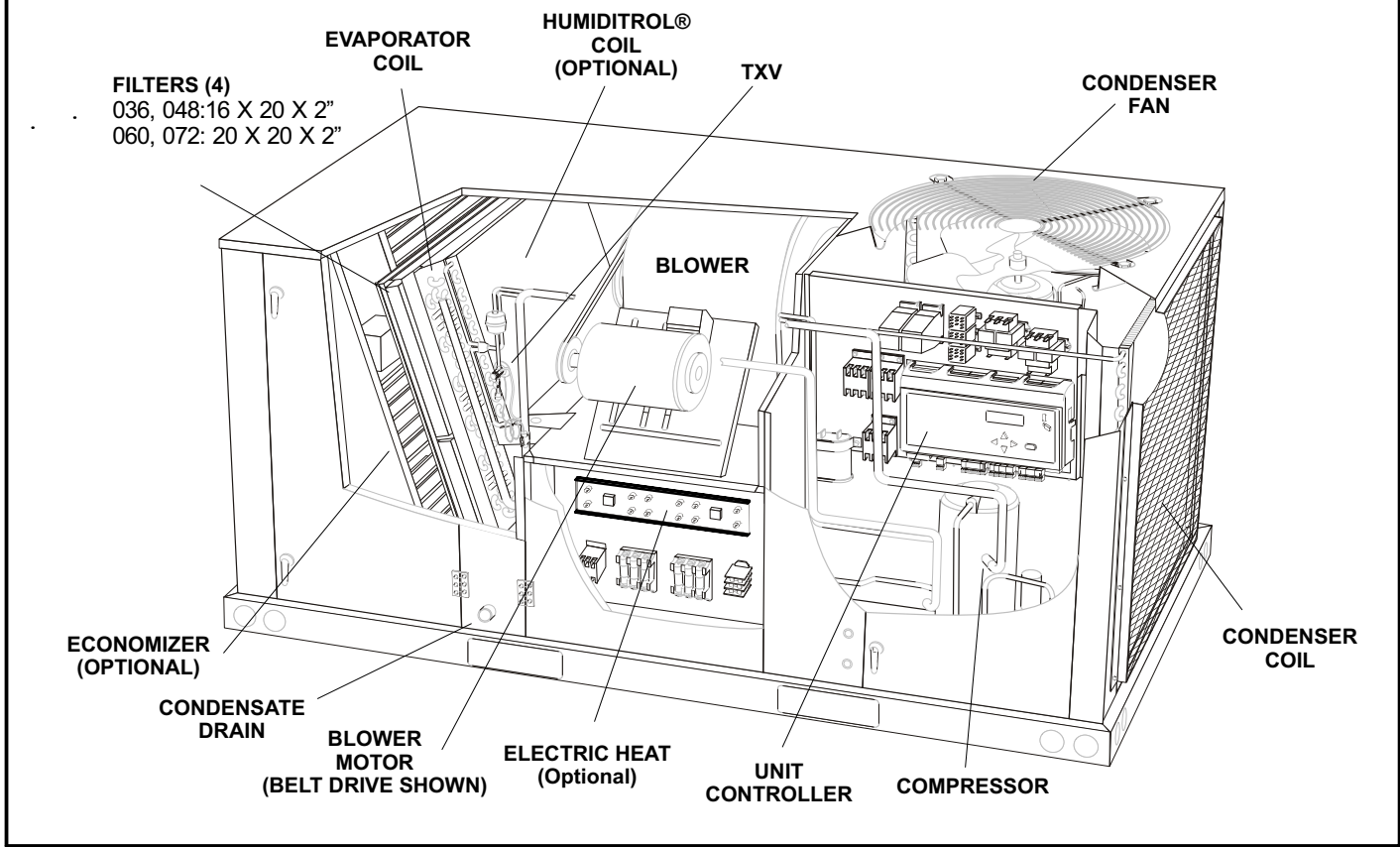

FIGURE 1

## LCH CONTROL BOX

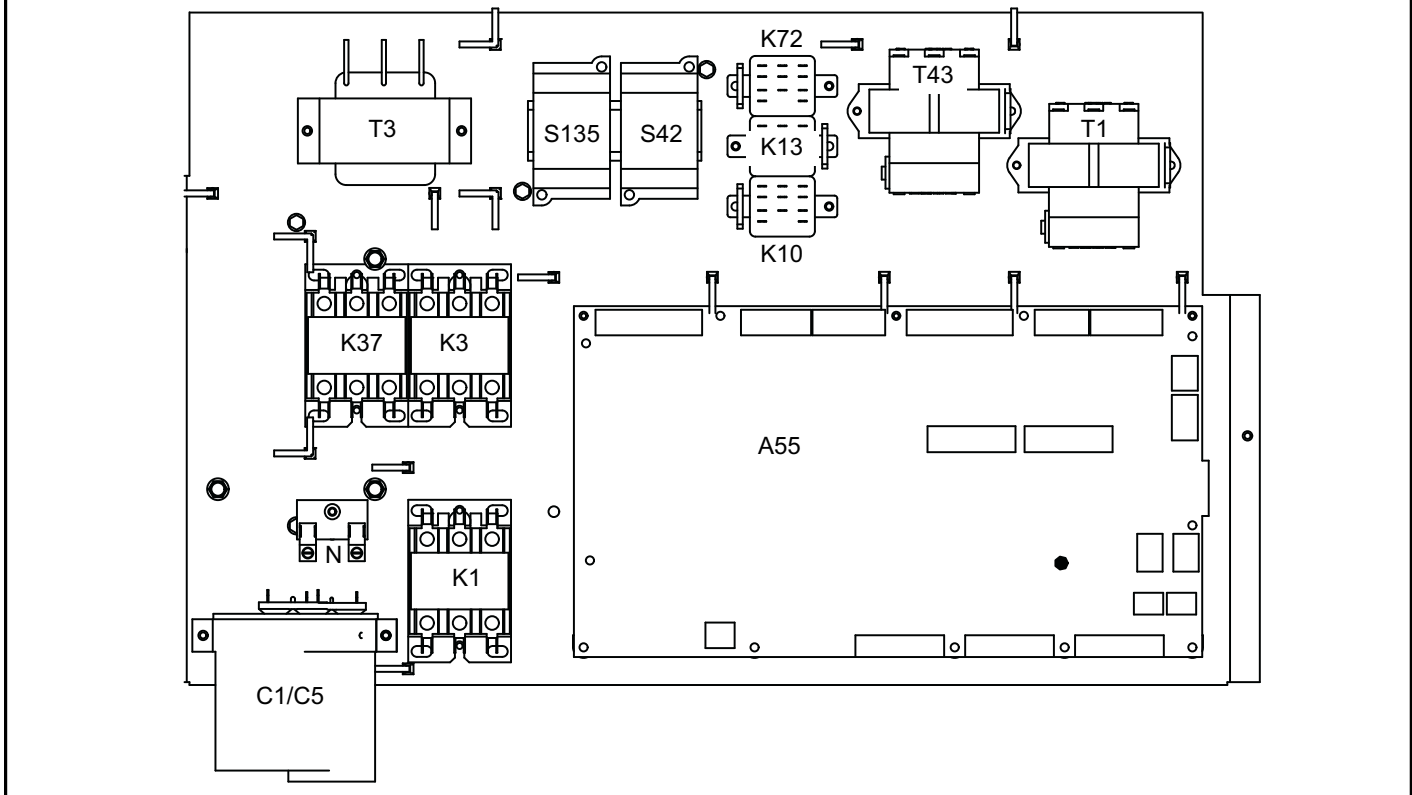

FIGURE 2

## I-UNIT COMPONENTS

All 3 through 6 ton (7 through 21 kW) units are configured to order units (CTO). The LCH unit components are shown in figure 1. All units come standard with removable unit panels. All L1, L2, and L3 wiring is color coded; L1 is red/pink, L2 is yellow, and L3 is blue.

### A-Control Box Components

LCH control box components are shown in figure 2. The control box is located in the upper right portion of the compressor compartment.

#### 1-Control Transformer T1

All use a single line voltage to 24VAC transformer mounted in the control box. Transformer supplies power to control circuits in the unit. The transformer is rated at 70VA and is protected by a 3.5 amp circuit breaker (CB8). The 208/230 (Y) voltage transformers use two

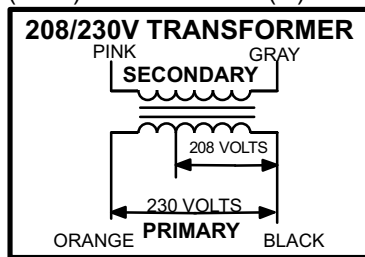

FIGURE 3

primary voltage taps as shown in figure 3, while 460 (G) and 575 (J) voltage transformers use a single primary voltage tap.

#### 2-Transformer T4 (G, J voltage)

All (G, J) 460, 575 voltage direct drive units use transformer T4 mounted in the control box. T4 is a line voltage to 230V transformer to power the indoor blower and outdoor fan motor. It is connected to line voltage and is powered at all times.

#### 3-Transformer T43 (reheat units)

All reheat units and units with phase detection components are equipped with T43 located in the control box. Transformer is rated at 70VA. It is connected to line voltage and is powered at all times.

#### 4-Unit Controller A55

The Unit Controller provides all unit control functions, unit status information, unit diagnostics, programmable parameters, and USB verification and profile sharing. Refer to the Unit Controller guide provided with the unit.

Thermostat wires are connected to J297 on the Unit Controller.

#### 5-Fan Capacitor C1 (three phase, belt drive)

Fan capacitor C1 is used to assist in the start up of condenser fan B4. Ratings will be on the side of capacitor or outdoor fan motor nameplate.

#### 6-Compressor Capacitor C5

Compressor capacitor C5 is used to assist in the start up of compressor B1 in single phase units. Ratings will be on the side of capacitor or compressor nameplate.

#### 7-Compressor Contactor K1

In all LCH units, K1 energizes compressor B1 in response to Unit Controller demand. Three phase units use three pole double break contactors with a 24 volt coil. Single phase units use single pole double break contactors with a 24 volt coil.

#### 8-Blower Contactors K3, K37 (belt drive)

K3 and K37 are three-pole, double-break contactors with 24VAC coils. On 3-, 4-, and 5-ton units, K3 energizes the B3 indoor blower motor on low speed and K37 energizes the blower motor on high speed. On 6-ton units, K3 energizes the B3 single-stage blower motor in response to blower demand.

#### 9-Blower Overloads S42, S135 (belt drive)

S42 and S135 are three phase thermal overload relays. See figure 4 or 5. Switches are connected in line with the blower motor to monitor the current flow to the motor. When the relay senses current exceeds the operating limits of the motor, a set of normally closed contacts open to de-energize the blower. On 3-, 4- and 5-ton unit blowers, S42 is used on low speed and S135 is used on high speed. On 6-ton unit blowers, S42 is used on single speed. Overload should be set to the full load current ratings on the motor nameplate.

#### 10-Condenser Fan Relay K10 (belt drive)

Outdoor fan relay K10 is an optional DPDT relay with a 24VAC coil. K10 energizes condenser fan B4.

## TELEMECANIQUE OVERLOAD RELAY

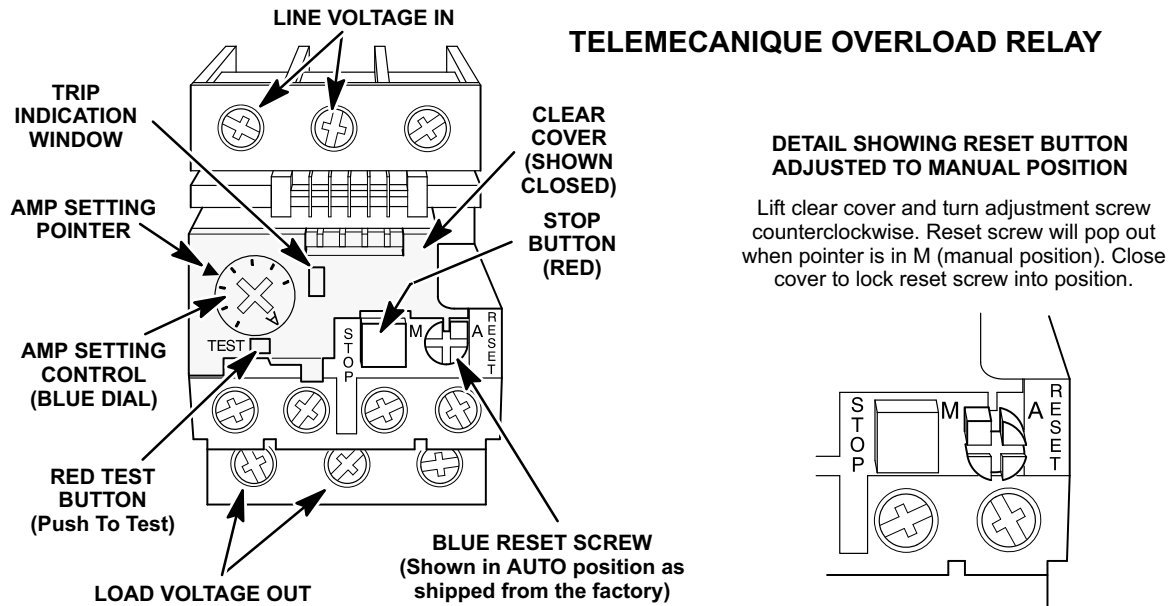

Lift clear cover to adjust relay amp setting according to value given on the blower motor nameplate. Proper relay amp setting equals motor nameplate FLA. Cover must also be lifted to adjust control mode from automatic reset to manual reset (see detail above) and to test the control. Control must be in the manual reset mode to perform a test. Use a pointed object to press the small red test button. A yellow marker should appear in the trip indication window to the right of the amp setting control. Press the blue reset screw to reset the relay. The red STOP button opens the normally closed contacts which power the blower motor. This button stops blower motor operation as long as it is pressed in.

FIGURE 4

## SIEMENS OVERLOAD RELAY

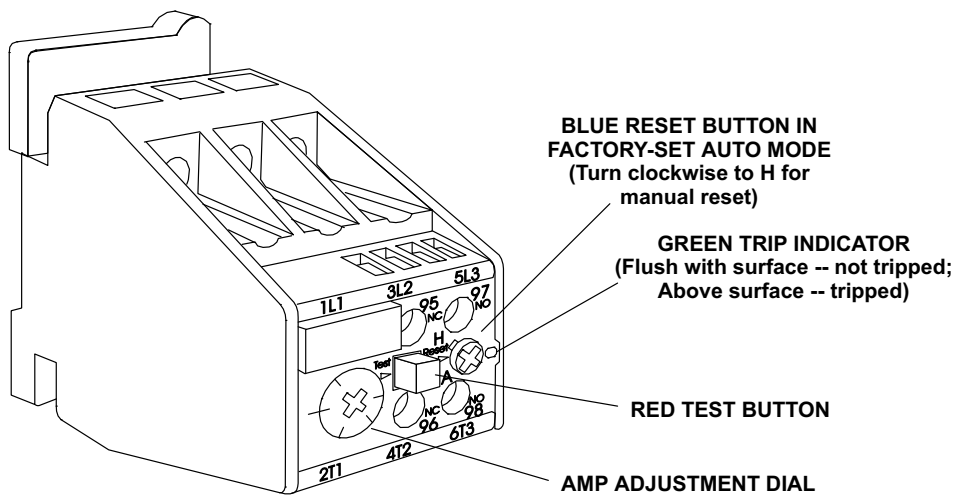

Adjust relay amp setting according to value given on the blower motor nameplate. Proper relay amp setting equals motor nameplate FLA. Use small slotted screwdriver to adjust control mode from automatic reset (A) to manual reset (H). Control must be in the manual reset mode (H) to perform a test. Press the red test button. Green trip indicator should pop out. Press the blue reset screw to reset the relay.

FIGURE 5

## B-Cooling Components

All units use independent cooling circuits consisting of separate compressor, condenser coil and evaporator coil. See figure 6. One draw-through type condenser fan is used in LCH036/072 units. Units are equipped with belt-drive or direct drive blowers which draw air across the evaporator during unit operation.

Cooling may be supplemented by a factory- or field-installed economizer. The evaporator coil is slab type and uses a thermostatic expansion valve as the primary refrigerant metering device. Each evaporator is also equipped with enhanced fins and rifled tubing. In all units each compressor is protected by a freezestat (S49) on the evaporator coil, a high pressure switch (S4) on the discharge line, and a low pressure switch (S87) on the suction line. See figure 6. A low ambient switch (S11) is standard.

### 1-Compressor B1

All LCH036-060 units use one two-stage scroll compressor. LCH072 units use one single-stage scroll compressor. See "SPECIFICATIONS" and "ELECTRICAL DATA" (table of contents) or compressor nameplate for compressor specifications.

## WARNING

**Electrical shock hazard. Compressor must be grounded. Do not operate without protective cover over terminals. Disconnect power before removing protective cover. Discharge capacitors before servicing unit. Failure to follow these precautions could cause electrical shock resulting in injury or death.**

Each compressor is energized by a corresponding compressor contactor.

*NOTE-Refer to the wiring diagram section for specific unit operation.*

### 2-Freezestat S49

Each unit is equipped with a low temperature switch (freezestat) located on a return bend of each evaporator coil.

The freezestat is wired to the A55 Unit Controller. The freezestat is a SPST N.C. auto-reset switch which opens at  $29^{\circ}\text{F} \pm 3^{\circ}\text{F}$  ( $-1.7^{\circ}\text{C} \pm 1.7^{\circ}\text{C}$ ) on a temperature drop and closes at  $58^{\circ}\text{F} \pm 4^{\circ}\text{F}$  ( $14.4^{\circ}\text{C} \pm 2.2^{\circ}\text{C}$ ) on a temperature rise. To prevent coil icing, freezestats open during compressor operation to temporarily disable the respective compressor until the coil temperature rises.

If the freezestats are tripping frequently due to coil icing, check the airflow / filters, economizer position and unit charge before allowing unit back in operation. Make sure to eliminate conditions which might promote evaporator ice buildup.

### 3-High Pressure Switch S4

The high pressure switch is a auto-reset SPST N.C. switch which opens on a pressure rise.

S4 is located in the compressor discharge line and wired to the A55 Unit Controller.

When discharge pressure rises to  $640 \pm 10$  psig ( $4412 \pm 69$  kPa) (indicating a problem in the system) the switch opens and the respective compressor is de-energized (the economizer can continue to operate). The switch automatically resets at  $475 \pm 10$  psig.

### 4-Low Ambient Switch S11

The low ambient switch is used to maintain cooling operation during low ambient temperatures. The switch opens to de-energize the outdoor fan (via A55) while mechanical cooling continues to operate. The reduced heat transfer across the outdoor coil results in higher refrigerant temperatures and prevents indoor coil icing.

The low ambient switch is an auto-reset SPST N.O. pressure switch and is located in the liquid line prior to the indoor coil section. The switch is wired to the A55 Unit Controller which uses the S11 input to control the outdoor fan when outdoor temperatures drop below  $62^{\circ}\text{F}$ . S11 opens when the liquid pressure drops below  $240 \pm 10$  psig ( $1655 \pm 69$  kPa). S11 closes when the liquid pressure rises to  $450 \pm 10$  psig ( $3102 \pm 69$  kPa) psig. The S11 switch will continue to cycle the outdoor fan until the outdoor temperature rises to  $65^{\circ}\text{F}$ .

*Units Equipped With Direct Drive Blowers -*

When the liquid pressure rises to 450 psig, the outdoor fan is energized at extra low RPM. This reduces the number of outdoor fan on/off cycles and refrigerant pressure fluctuations. The outdoor fan will continue to operate at extra low RPM until the outdoor temperature rises to  $65^{\circ}\text{F}$ .

### 5-Low Pressure Switch S87

The compressor circuit is protected by a low pressure switch located on the suction line. Switch opens at  $40$  psig  $\pm 5$  psig ( $276 \pm 34$  kPa) and automatically resets at  $90$  psig  $\pm 5$  psig ( $621$  kPa  $\pm$  kPa).

### 6-Crankcase Thermostat S40

Switch opens when discharge line temperature reaches  $94^{\circ}\text{F} \pm 5$  ( $34^{\circ}\text{C} \pm 3$ ) and closes when temperature falls below  $74^{\circ}\text{F} \pm 5$  ( $23^{\circ}\text{C} \pm 3$ ). Prevents crankcase heater operation in warm weather.

# LCH PLUMBING and S49 FREEZESTAT LOCATION

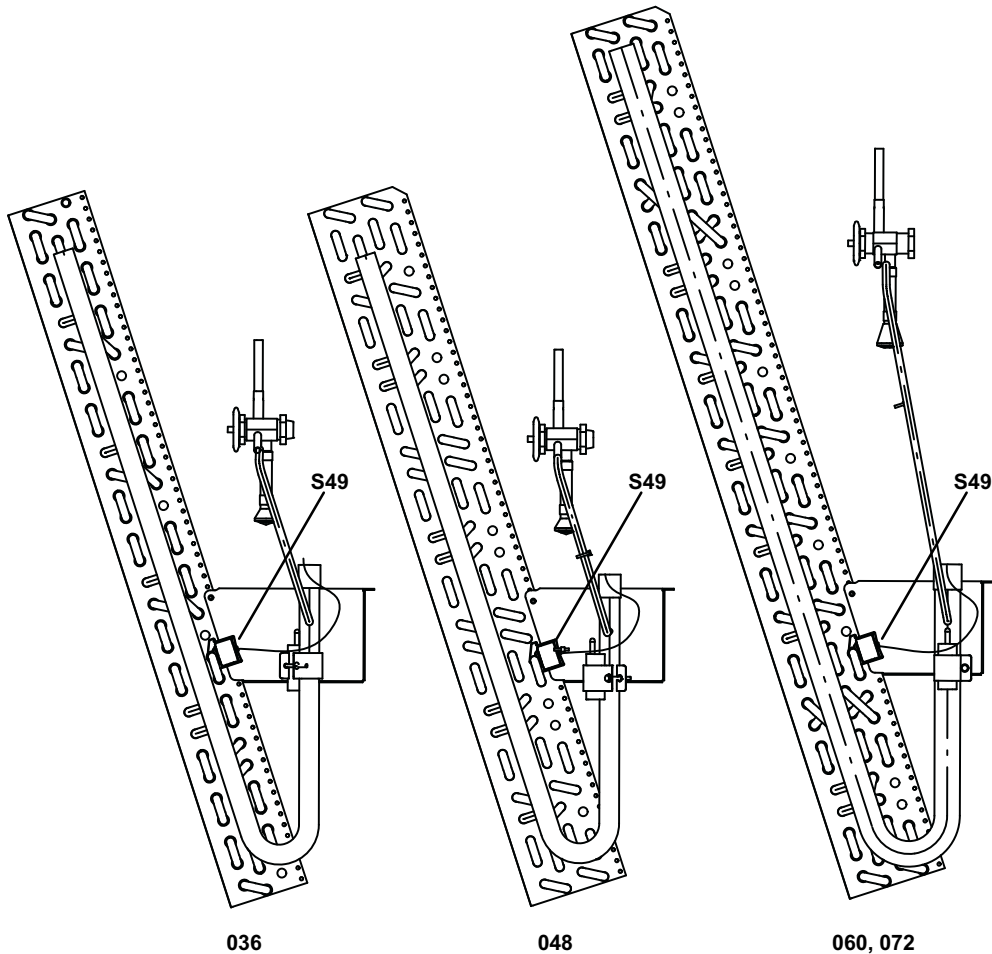
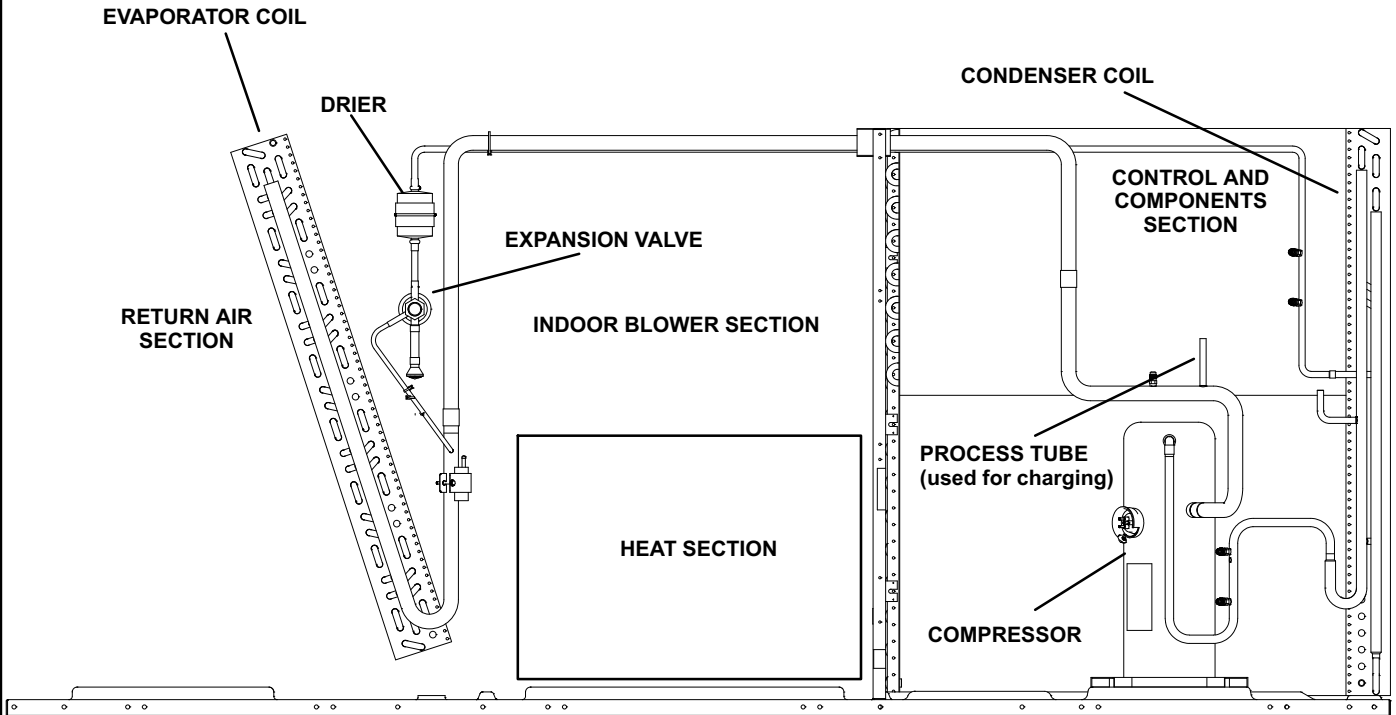

FIGURE 6



## C-Blower Compartment

LCH036H, 048H, and 060H units are equipped with direct drive blowers. LCH036S, 048S, and 060S units are equipped with two-speed, belt drive blowers. LCH072H units are equipped with a single-speed belt drive blower. See unit nameplate for blower type. The blower compartment in all LCH036/072 units is located between the evaporator coil and the compressor compartment.

### 1-Blower Wheels

See table 1 for blower wheel type and size.

**TABLE 1**  
**BLOWER WHEELS**

LCH Unit	Type	Size - in. (mm)
036S, 048S, 060S	Belt	10 X 10 (254 X 254)
036H, 048H	Direct	
060H	Direct	11 X 10 (279 X 254)
072H	Belt	15 X 9 (381 X 229)

### 2-Indoor Blower Motor B3

All direct drive blower motors are electronically commutated, brushless, DC motors. Belt drive blower motors are single (6-ton) or two-speed (3, 4, 5 ton) integral motors. Low speed is approximately 2/3 of high speed. CFM adjustments on belt drive units are made by adjusting the motor pulley (sheave). CFM adjustments on direct drive units are made by changing ECTO parameters as shown in the Unit Controller manual provided with each unit. Motors are equipped with sealed ball bearings. All motor specifications are listed in the SPECIFICATIONS (table of contents) in the front of this manual. Units may be equipped with motors manufactured by various manufacturers, therefore electrical FLA and LRA specifications will vary. See unit rating plate for information specific to your unit.

## **⚠ IMPORTANT**

**Three phase scroll compressors must be phased sequentially for correct compressor and blower rotation. Follow "COOLING START-UP" section of installation instructions to ensure proper compressor and blower operation.**

### A-Blower Operation

Refer to the Unit Controller Installation and Setup Guide to energize blower. Use the menu navigation arrows and select button; see *Service - Test*.

### B-Determining Unit CFM

- 1- The following measurements must be made with air filters in place.

**IMPORTANT** - On units equipped with direct drive blowers, determine and adjust high speed CFM before low speed CFM. Low speed CFM should be adjusted to 2/3 of high speed CFM. A low speed adjustment less than 2/3 of high speed will improve humidity removal; refer to product data for more information.

- 2- With all access panels in place, measure static pressure external to unit (from supply to return). Pressure tap locations should be approximately one foot from openings.
- 3- Measure the indoor blower wheel RPM. RPM can be read from the A55 Unit Controller display on direct drive blowers. See Unit Controller manual.
- 4- Referring to Page 11 through Page 18, use static pressure and RPM readings to determine unit CFM. Use Page 19 and Page 20 when installing units with any of the options or accessories listed.

### C-Adjusting Unit CFM - Direct Drive Blowers

The supply CFM can be adjusted by changing Unit Controller settings; see the Unit Controller guide provided with the unit. Refer to table 2. Adjustments can also be made by using optional software. Record any CFM changes on the ECTO Settings label located on the inside of the compressor access panel.

### D-Adjusting Unit CFM - Belt Drive Blowers

The blower RPM can be adjusted at the motor pulley. Loosen Allen screw and turn adjustable pulley clockwise in 1/2-turn increments to increase CFM. Turn counterclockwise in 1/2-turn increments to decrease CFM. See figure 7. Do not exceed minimum and maximum number of pulley turns as shown in table 3.

### E-Blower Belt Adjustment - Belt Drive

Maximum life and wear can be obtained from belts only if proper pulley alignment and belt tension are maintained. Tension new belts after a 24-48 hour period of operation. This will allow belt to stretch and seat grooves. Make sure blower and motor pulley are aligned as shown in figure 8.

- 1- Loosen four bolts securing motor base to mounting frame. See figure 7.
- 2- *To increase belt tension* - Slide blower motor downward to tighten the belt. This increases the distance between the blower motor and the blower housing.
- 3- *To loosen belt tension* - Slide blower motor upward to loosen the belt. This decreases the distance between the blower motor and the blower housing.
- 4- Tighten four bolts securing motor base to the mounting frame.

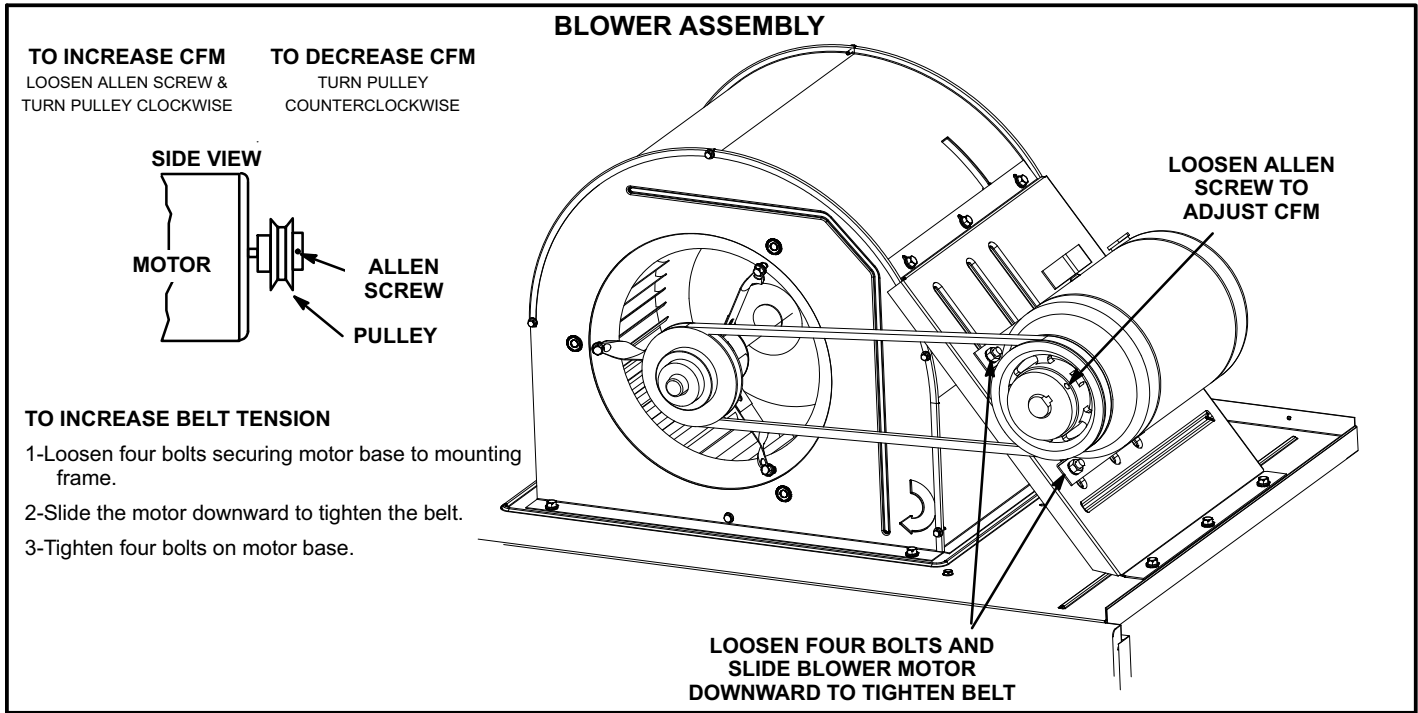

FIGURE 7

**TABLE 2  
ECTO SETTINGS**

Unit Controller "SETTINGS-CONTROL-MSAV" Menu	ECTO	LCH/LCH Unit Factory Settings				Field Setting	Description
		036 H4E	048 H4E	060 H4E	036-060 S4T		
SMOKE SPEED	0.02	55	80	59	Not Applicable	% torque for indoor blower smoke speed.	
HIGH SPEED	0.04	55	80	59	Not Applicable	% torque for indoor blower high speed.	
LOW SPEED	0.05	28	40	36	Not Applicable	% torque for indoor blower low speed.	

Unit Controller "SETTINGS-SETPOINTS-DAMPER" Menu	ECTO	LCH/LCH Unit Factory Settings				Field Setting	Description
		036 H4E	048 H4E	060 H4E	036-060 S4T		
MIN OCP BLOWER LOW	0.09	30	30	30	30	Damper minimum position during low indoor blower.	
MIN OCP BLOWER HIGH*	5.24	101	101	101	101	Damper minimum position during high indoor blower.	

\*101 setting allows manual potentiometer control on the A55 Unit Controller.

Installer: Circle applicable unit model number and record any ECTO changes under "Field Setting" column. Settings need to be recorded by installer for use when unit controller is replaced or reprogrammed. Refer to unit controller guide "Setting" menu path or use optional software to change settings.

**TABLE 3  
MINIMUM AND MAXIMUM PULLEY ADJUSTMENT**

Belt	Min. Turns Open	Maxi. Turns Open
A Section	No minimum	5

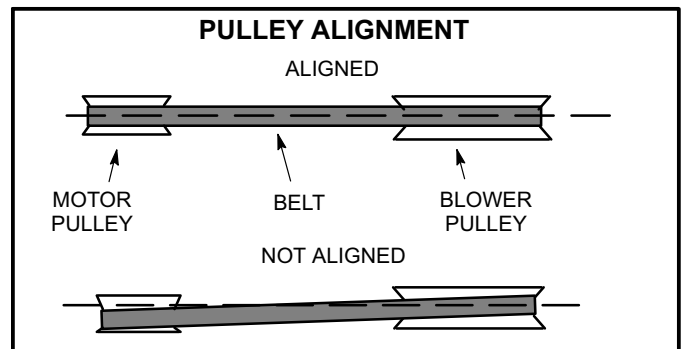
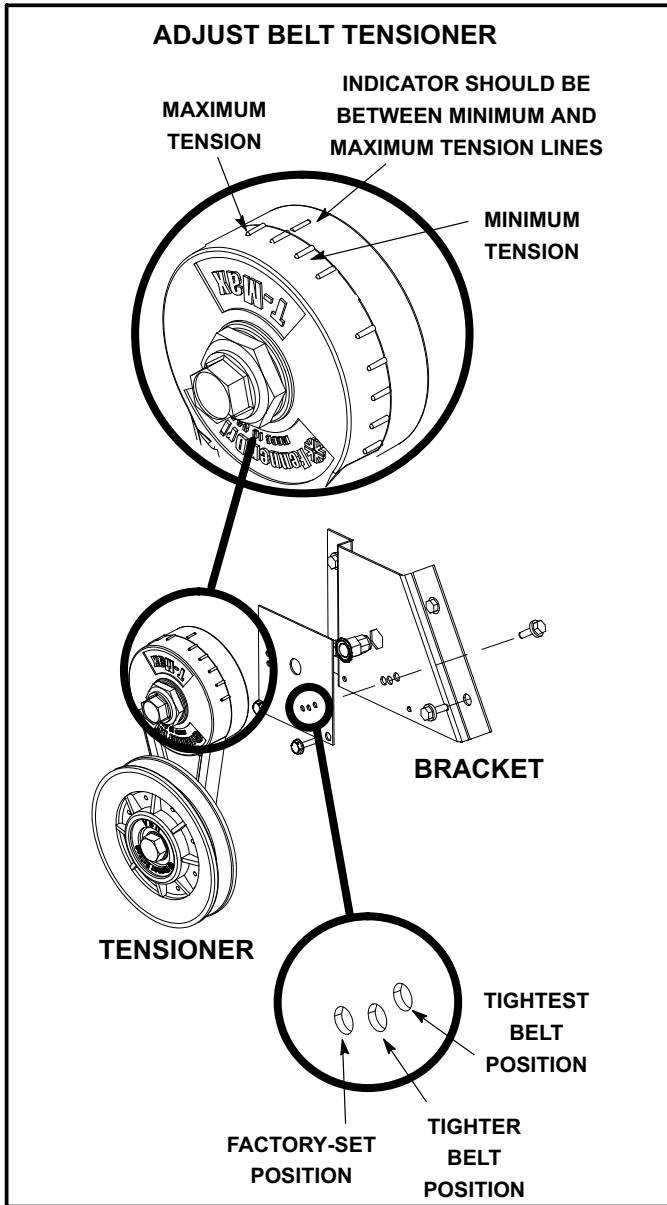

FIGURE 8

**F-Blower Belt Adjustment - Units Equipped With An Optional Belt Tensioner**

- 1- Remove blower belt.
- 2- Remove bracket from blower housing. See figure 9.
- 3- Remove the screw from the back side of the bracket.
- 4- Move the tensioner to the appropriate adjustment hole and reinstall screw.
- 5- Replace bracket.
- 6- Replace blower belt. See figure 10.



**FIGURE 9**

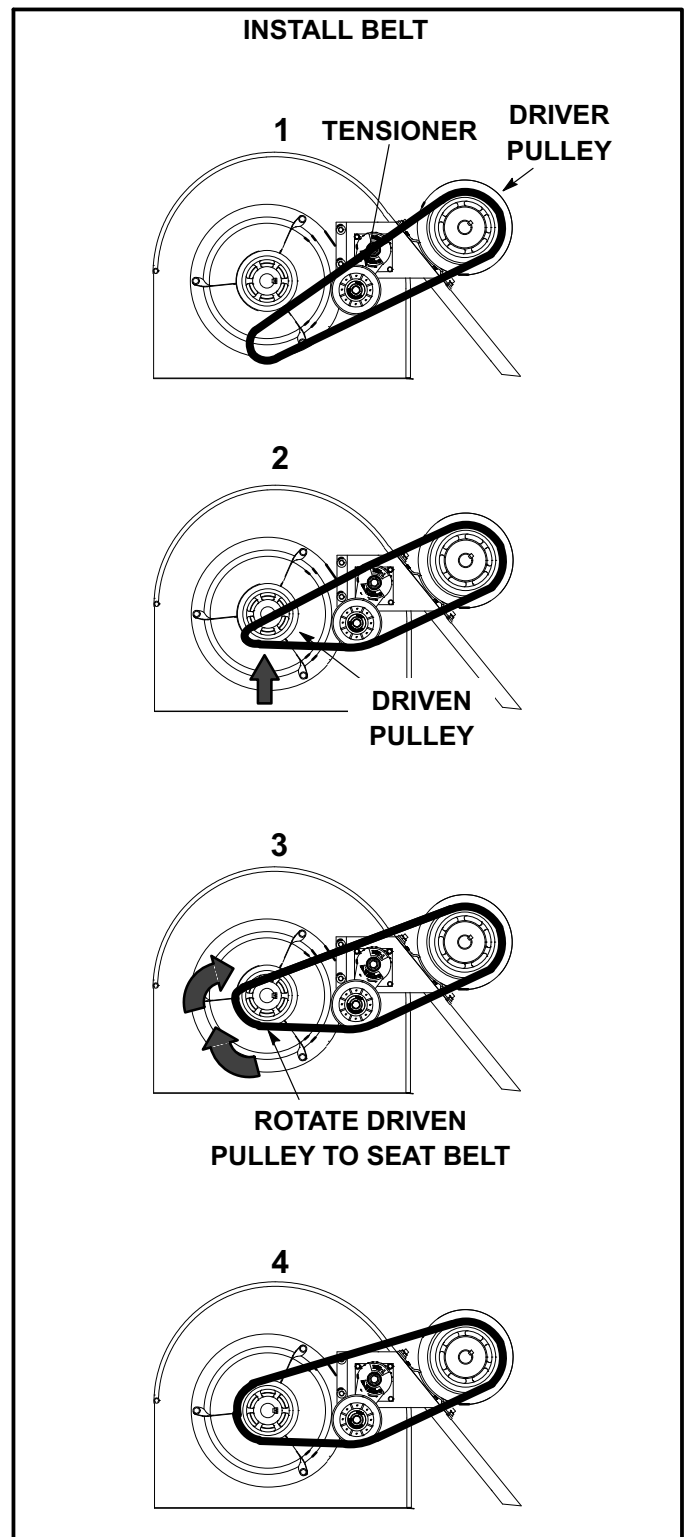

**FIGURE 10**

## G-Check Belt Tension

Overtensioning belts shortens belt and bearing life. Check belt tension as follows:

- 1- Measure span length X. See figure 11.
- 2- Apply perpendicular force to center of span (X) with enough pressure to deflect belt 1/64" for every inch of span length or 1.5mm per 100mm of span length.

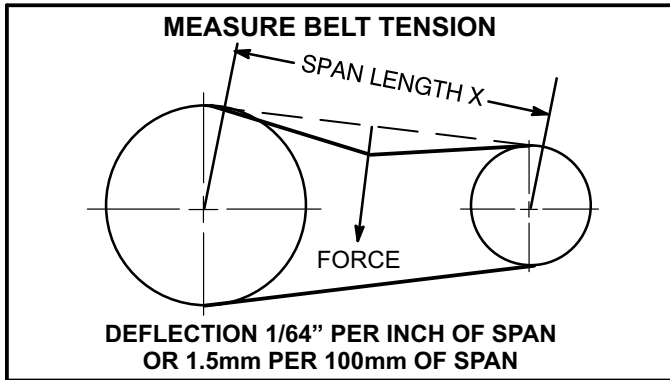

FIGURE 11

Example: Deflection distance of a 40" span would be 40/64" or 5/8".

Example: Deflection distance of a 400mm span would be 6mm.

- 3- Measure belt deflection force. For a used belt, the deflection force should be 5 lbs. (35kPa). A new belt deflection force should be 7 lbs. (48kPa).

A force below these values indicates an undertensioned belt. A force above these values indicates an overtensioned belt.

## H-Field-Furnished Blower Drives

For field-furnished blower drives, use Page 11 through Page 18 to determine BHP and RPM required. Reference table 4 to determine the drive kit number.

**TABLE 4  
MANUFACTURER'S DRIVE COMPONENT NUMBERS**

Drive No.	DRIVE COMPONENTS					
	Motor Pulley		Blower Pulley		Belt	
	Supplier No.	OEM Part No.	Supplier No.	OEM Part No.	Supplier No.	OEM Part No.
A01	1VP34x7/8	31K6901	AK54 x 1	100244-19	A40	100245-17
A02	1VP34x7/8	31K6901	AK49 x 1	100244-18	A39	100245-16
A03	1VP34x7/8	31K6901	AK44 x 1	100244-16	A39	100245-16
A05	1VP34x7/8	31K6901	AK41 x 1	100244-15	A39	100245-16
A06	1VP44x7/8	P-8-1488	AK51 x 1	18L2201	A41	100245-18
A07	1VP50x7/8	P-8-2187	AK54 x 1	100244-19	AX43	73K8201
AA01	1VP34x7/8	31K6901	AK69 x 1	37L4701	AX51	13H0101
AA02	1VP40x7/8	79J0301	BK80H <sup>1</sup>	100788-03	A53	P-8-4951
AA03	1VP40x7/8	79J0301	AK59 x 1	31K6801	A50	100245-29
AA04	1VP44x7/8	P-8-1488	AK59 x 1	31K6801	AX51	13H0101
A01T <sup>2</sup>	1VP34x7/8	31K6901	AK54 x 1	100244-19	A41	100245-18
A02T <sup>2</sup>	1VP34x7/8	31K6901	AK49 x 1	100244-18	A40	100245-17
A03T <sup>2</sup>	1VP34x7/8	31K6901	AK44 x 1	100244-16	A40	100245-17
A05T <sup>2</sup>	1VP34x7/8	31K6901	AK41 x 1	100244-15	A41	100245-18
A06T <sup>2</sup>	1VP44x7/8	P-8-1488	AK51 x 1	18L2201	A41	100245-18
A07T <sup>2</sup>	1VP50x7/8	P-8-2187	AK54 x 1	100244-19	AX43	73K8201
AA01T <sup>2</sup>	1VP34x7/8	31K6901	AK69 x 1	37L4701	A50	100245-29
AA02T <sup>2</sup>	1VP40x7/8	79J0301	BK80H*	100788-03	A52	100245-30
AA03T <sup>2</sup>	1VP40x7/8	79J0301	AK59 x 1	31K6801	A49	100245-32
AA04T <sup>2</sup>	1VP44x7/8	P-8-1488	AK59 x 1	31K6801	A50	100245-29

NOTES: <sup>1</sup> Requires split taper bushing, Browning no. H1; OEM no. 100073-04 <sup>2</sup> Includes tension assembly, Fenner no. FS0590; OEM no. 101994-02

## D-ELECTRIC HEAT COMPONENTS

Electric heat match-ups are found in the ELECTRICAL DATA tables. See table of contents.

All electric heat sections consist of electric heating elements exposed directly to the air stream. See figure 12. See figure 13 for vestibule parts arrangement.

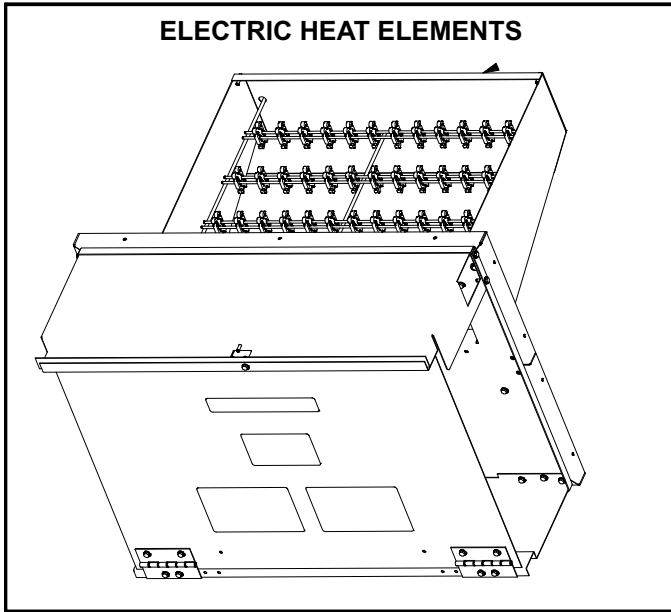

FIGURE 12

### 1-Contactors K15, K16

All contactors are double break and either single, double or three pole (see diagram) and equipped with a 24VAC coil. The coils in the K15 and K16 contactors are energized by the indoor thermostat. In all units K15 energizes the heating elements, while in the 22.5 kW units, K15 and K16 energize the heating elements simultaneously.

### 2-High Temperature Limits S15 (Primary)

S15 is a SPST N.C. auto-reset thermostat located on the back panel of the electric heat section above the heating elements. S15 is the high temperature limit for the electric heat section. When S15 opens, indicating a problem in the system, contactor K15 is de-energized (including K16 in 22.5 kW units). When K15 is de-energized, all stages of heat are de-energized. See table 5 for S15 set points. Set points are factory set and not adjustable.

TABLE 5

Unit kW (Voltage)	S15 Opens ° F	S15 Closes ° F
7.5 (Y, G, J, P)	160	120
15 (Y)	170	130
15 (G, J, P)	160	120
22.5 (Y, G, J)	160	120
22.5 (P)	150	110
30 (Y, G, J)	150	110

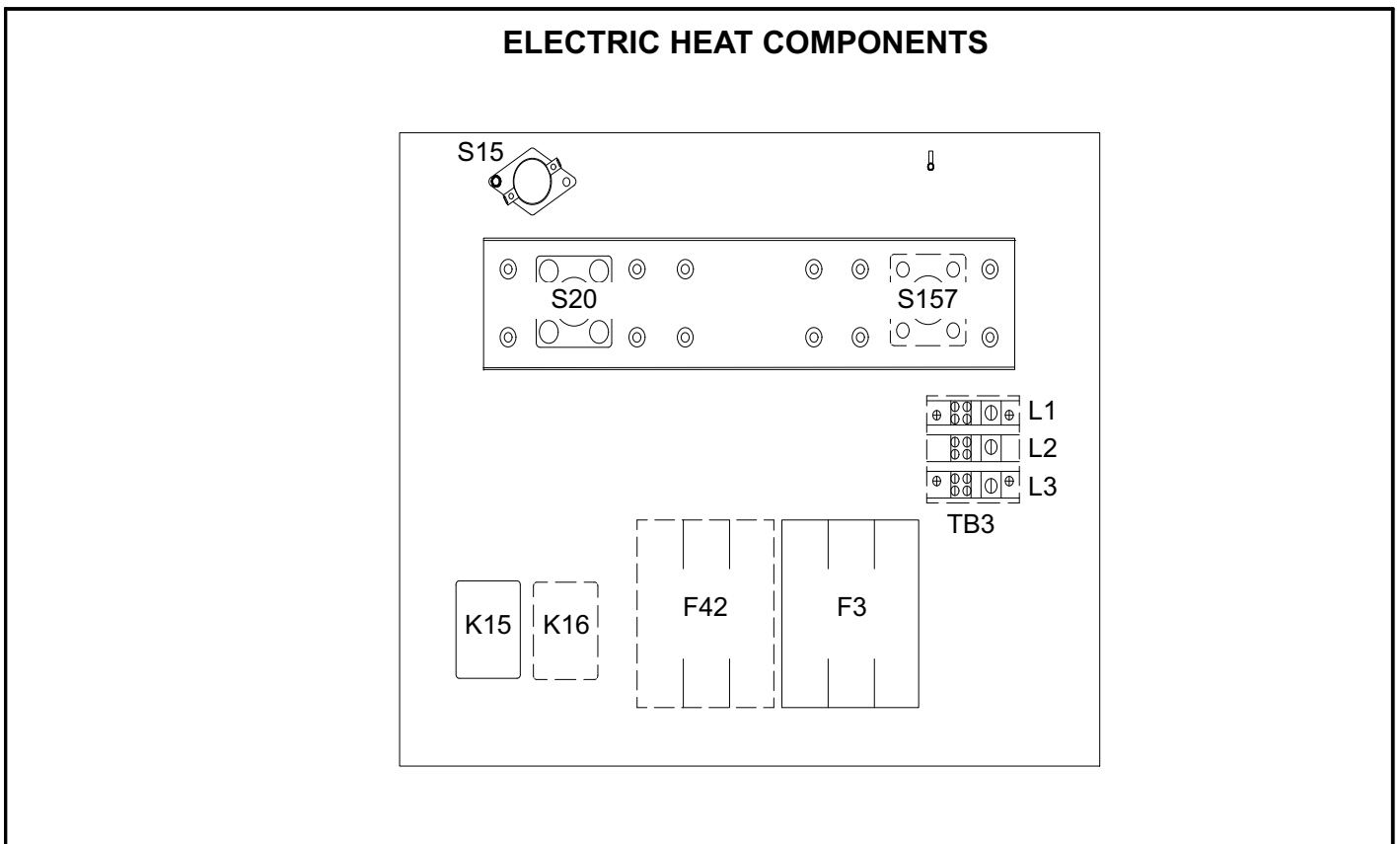

FIGURE 13

### 3-High Temperature Limit S20 and S157 (Secondary)

S20 and S157 are SPST N.C. manual-reset thermostat s. S20 and S157 are wired in series with the heating elements. See E1EH wiring diagrams. When S20 or S157 open, power is interrupted to the heating elements which are wired in series with the limits. K15/K16 are only de-energized when S15 opens. When the contactors are de-energized, all stages of heat are de-energized. The thermostat is factory set to open at 220°F ± 6°F (104°C ± 3.3°C) on a temperature rise and can be manually reset when temperature falls below 160°F (71.0°C). See figure 13 for location.

### 4-Terminal Strip TB2

Terminal strip TB2 is used for single point power installations only. TB2 distributes power to TB3. Units with multi-point power connections will not use TB2.

### 5-Terminal Strip TB3

P and Y voltage units are equipped with terminal strip TB3. Electric heat line voltage connections are made to TB3, which distributes power to the electric heat components and is located on the vestibule. See figure 13.

### 6-Heating Elements HE1 through HE6

Heating elements are composed of helix wound bare nichrome wire exposed directly to the air stream. Three elements are connected in a three-phase arrangement. The elements in 208/230V units are connected in a “Delta” arrangement. Elements in 460 and 575V units are connected in “Wye” arrangement. Each stage is energized independently by the corresponding contactors located on the electric heat vestibule panel. Once energized, heat transfer is instantaneous. High temperature protection is provided by primary and redundant high temperature limits and overcurrent protection is provided by fuses.

### 7-Fuse F3

Fuse F3 is housed in a fuse block which holds two or three fuses. Each F3 fuse is connected in series with each leg of electric heat. Figure 13 and table 6 show the fuses used with each electric heat section.

### 8-Unit Fuse Block & Fuse F4

Three line voltage fuses F4 provide short circuit and ground fault protection to all cooling components in the LCH units with electric heat. The fuses are rated in accordance with the amperage of the cooling components. The F 4 fuse block is located inside a sheet metal enclosure .

**TABLE 6**

Unit	Voltage-Phase	FUSE	Qty	Qty
		F3	each	total
E1EH0075	208/230V-1P	40 A-250V	2	2
	208/230V-3P	25 A-250V	3	3
	460V-3P	15 A-600V	3	3
	575V-3P	15 A-600V	3	3
E1EH0150	208/230V-1P	40 A-250V	2	4
	208/230V-3P	50 A-250V	3	3
	460V	25 A-600V	3	3
	575V	20 A-600V	3	3
E1EH0225	208/230V-1P	40 A-250V	3	6
	208/230V-3P	45 A-250V	3	6
	460V-3P	35 A-600V	3	3
	575V-3P	30 A-600V	3	3
E1EH0300	208/230V-3P	60 A-250V	3	6
	460V-3P	50 A-600V	3	3
	575V-3P	40 A-600V	3	3

## II-PLACEMENT AND INSTALLATION

Make sure the unit is installed in accordance with the installation instructions and all applicable codes. See accessories section for conditions requiring use of the optional roof mounting frame (T1CURB-AN or C1CURB-AN).

## III-START UP - OPERATION

### A-Preliminary and Seasonal Checks

- 1- Make sure the unit is installed in accordance with the installation instructions and applicable codes.
- 2- Inspect all electrical wiring, both field and factory installed for loose connections. Tighten as required. Refer to unit diagram located on inside of unit compressor access panel.
- 3- Check to ensure that refrigerant lines are in good condition and do not rub against the cabinet or other refrigerant lines.
- 4- Check voltage at the disconnect switch. Voltage must be within the range listed on the nameplate. If not, consult the power company and have the voltage corrected before starting the unit.
- 5- Recheck voltage and amp draw with unit running. If voltage is not within range listed on unit nameplate, stop unit and consult power company. Refer to unit nameplate for maximum rated load amps.
- 6- Inspect and adjust blower belt (see section on Blower Compartment - Blower Belt Adjustment).

## IV-CHARGING

**WARNING-Do not exceed nameplate charge under any condition.**

This unit is factory charged and should require no further adjustment. If the system requires additional refrigerant, reclaim the charge, evacuate the system, and add required nameplate charge.

*NOTE - System charging is not recommended below 60°F (15°C). In temperatures below 60°F (15°C), the charge must be weighed into the system.*

If weighing facilities are not available, or to check the charge, use the following procedure:

- 1- Attach gauge manifolds and operate unit in cooling mode with economizer disabled until system stabilizes (approximately five minutes). Make sure outdoor air dampers are closed.
- 2- Use a thermometer to accurately measure the outdoor ambient temperature.
- 3- Apply the outdoor temperature to tables 7 through 20 to determine normal operating pressures. Pressures are listed for sea level applications at 80° F dry bulb and 67° F wet bulb return air.
- 4- Compare the normal operating pressures to the pressures obtained from the gauges. Minor variations in these pressures may be expected due to differences in installations. Significant differences could mean that the system is not properly charged or that a problem

exists with some component in the system. **Correct any system problems before proceeding.**

- 5- If discharge pressure is high, remove refrigerant from the system. If discharge pressure is low, add refrigerant to the system.
  - Add or remove charge in increments.
  - Allow the system to stabilize each time refrigerant is added or removed.
- 6- Use the following approach method along with the normal operating pressures to confirm readings.

**TABLE 7  
LCH036S NORMAL OPERATING PRESSURES**

Outdoor Coil Entering Air Temp	Discharge ±10 psig	Suction ± 5 psig
65° F	267	138
75° F	305	140
85° F	350	142
95° F	398	146
105° F	451	147
115° F	507	150

**TABLE 8  
LCH036S REHEAT NORMAL OPERATING PRESSURES**

Outdoor Coil Entering Air Temp	Discharge ±10 psig	Suction ± 5 psig
65° F	261	138
75° F	300	141
85° F	342	144
95° F	387	148
105° F	437	150
115° F	490	153

**TABLE 9  
LCH036H NORMAL OPERATING PRESSURES**

Outdoor Coil Entering Air Temp	Discharge ±10 psig	Suction ± 5 psig
65° F	262	142
75° F	293	145
85° F	345	147
95° F	389	149
105° F	439	152
115° F	493	155

**TABLE 10  
LCH036H REHEAT NORMAL OPERATING PRESSURES**

Outdoor Coil Entering Air Temp	Discharge ±10 psig	Suction ± 5 psig
65° F	262	139
75° F	299	141
85° F	342	144
95° F	388	147
105° F	437	150
115° F	491	153

**TABLE 11  
LCH048S NORMAL OPERATING PRESSURES**

Outdoor Coil Entering Air Temp	Discharge ±10 psig	Suction ± 5 psig
65° F	259	129
75° F	299	138
85° F	343	146
95° F	390	148
105° F	442	157
115° F	497	160

**TABLE 12  
LCH048S REHEAT NORMAL OPERATING PRESSURES**

Outdoor Coil Entering Air Temp	Discharge ±10 psig	Suction ± 5 psig
65° F	259	139
75° F	298	143
85° F	340	145
95° F	388	148
105° F	439	151
115° F	495	154

**TABLE 13  
LCH048H NORMAL OPERATING PRESSURES**

Outdoor Coil Entering Air Temp	Discharge ±10 psig	Suction ± 5 psig
65° F	256	122
75° F	299	132
85° F	342	139
95° F	388	145
105° F	437	150
115° F	493	153

**TABLE 14  
LCH048H REHEAT NORMAL OPERATING PRESSURES**

Outdoor Coil Entering Air Temp	Discharge ±10 psig	Suction ± 5 psig
65° F	261	138
75° F	299	142
85° F	342	144
95° F	389	147
105° F	441	150
115° F	497	153

**TABLE 15  
LCH060S NORMAL OPERATING PRESSURES**

Outdoor Coil Entering Air Temp	Discharge ±10 psig	Suction ± 5 psig
65° F	264	136
75° F	303	138
85° F	346	140
95° F	395	142
105° F	445	145
115° F	500	148

**TABLE 16  
LCH060S REHEAT NORMAL OPERATING PRESSURES**

Outdoor Coil Entering Air Temp	Discharge ±10 psig	Suction ± 5 psig
65° F	267	135
75° F	307	137
85° F	350	139
95° F	399	142
105° F	451	144
115° F	507	147

**TABLE 17  
LCH060H NORMAL OPERATING PRESSURES**

Outdoor Coil Entering Air Temp	Discharge ±10 psig	Suction ± 5 psig
65° F	253	136
75° F	291	137
85° F	334	139
95° F	380	142
105° F	427	145
115° F	479	148

**TABLE 18  
LCH060H REHEAT NORMAL OPERATING PRESSURES**

Outdoor Coil Entering Air Temp	Discharge ±10 psig	Suction ± 5 psig
65° F	256	136
75° F	295	138
85° F	337	140
95° F	384	143
105° F	432	146
115° F	488	147

**TABLE 19  
LCH072H NORMAL OPERATING PRESSURES**

Outdoor Coil Entering Air Temp	Discharge ±10 psig	Suction ± 5 psig
65° F	271	136
75° F	312	139
85° F	357	141
95° F	405	144
105° F	458	147
115° F	515	151

**TABLE 20  
LG072H REHEAT NORMAL OPERATING PRESSURES**

Outdoor Coil Entering Air Temp	Discharge ±10 psig	Suction ± 5 psig
65° F	272	137
75° F	312	139
85° F	356	140
95° F	403	142
105° F	453	145
115° F	507	148



### D-Charge Verification - Approach Method - AHRI Testing

- Using the same thermometer, compare liquid temperature to outdoor ambient temperature.

Approach Temperature = Liquid temperature (at condenser outlet) minus ambient temperature.

- Approach temperature should match values in table 21. An approach temperature greater than value shown indicates an undercharge. An approach temperature less than value shown indicates an overcharge.
- The approach method is not valid for grossly over or undercharged systems. Use tables 7 through 20 as a guide for typical operating pressures.

**TABLE 21  
APPROACH TEMPERATURE**

LCH/LCH Unit	Liquid Temp. Minus Ambient Temp.
036S & H Std. 036S & H Reheat 048H Std. 060S & H Reheat 060H Std. 072H Std.	6°F ± 1 (3.3°C ± 0.5)
048H Reheat 072H Reheat	7°F ± 1 (3.9°C ± 0.5)
048S Std. 060S Std.	8°F ± 1 (4.4°C ± 0.5)
048S Reheat	9°F ± 1 (5.0°C ± 0.5)

### V- SYSTEMS SERVICE CHECKS

#### A-Cooling System Service Checks

LCH units are factory charged and require no further adjustment; however, charge should be checked periodically using the approach method. The approach method compares actual liquid temperature with the outdoor ambient temperature. See section IV- CHARGING.

*NOTE-When unit is properly charged discharge line pressures should approximate those in tables 7 through 20.*

#### VI-MAINTENANCE

The unit should be inspected once a year by a qualified service technician.

### **! WARNING**



**Electric shock hazard. Can cause injury or death. Before attempting to perform any service or maintenance, turn the electrical power to unit OFF at disconnect switch(es). Unit may have multiple power supplies.**

### **! CAUTION**

**Label all wires prior to disconnection when servicing controls. Wiring errors can cause improper and dangerous operation. Verify proper operation after servicing.**

### **! WARNING**

**Product contains fiberglass wool. Disturbing the insulation in this product during installation, maintenance, or repair will expose you to fiberglass wool. Breathing this may cause lung cancer. (Fiberglass wool is known to the State of California to cause cancer.) Fiberglass wool may also cause respiratory, skin, and eye irritation. To reduce exposure to this substance or for further information, consult material safety data sheets available from address shown on unit nameplate or contact your supervisor.**

#### A-Filters

Units are equipped with temporary filters which must be replaced prior to building occupation. See table 22 for correct filter size. Refer to local codes or appropriate jurisdiction for approved filters.

**TABLE 22**

Unit	Qty	Filter Size - inches (mm)
036, 048	4	16 X 20 X 2 (406 X 508 X 51)
060, 072	4	20 X 20 X 2 (508 X 508 X 51)

*NOTE-Filters must be U.L.C. certified or equivalent for use in Canada.*

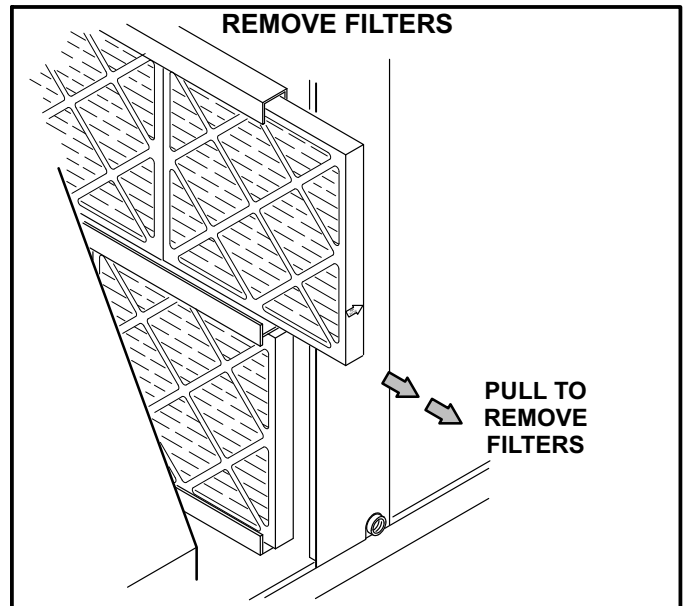

**FIGURE 14**

#### B-Lubrication

All motors are lubricated at the factory. No further lubrication is required.

#### C-Evaporator Coil

Inspect and clean coil at beginning of each cooling season. Clean using mild detergent or commercial coil cleanser. Flush coil and condensate drain with water taking care not to get insulation, filters and return air ducts wet.

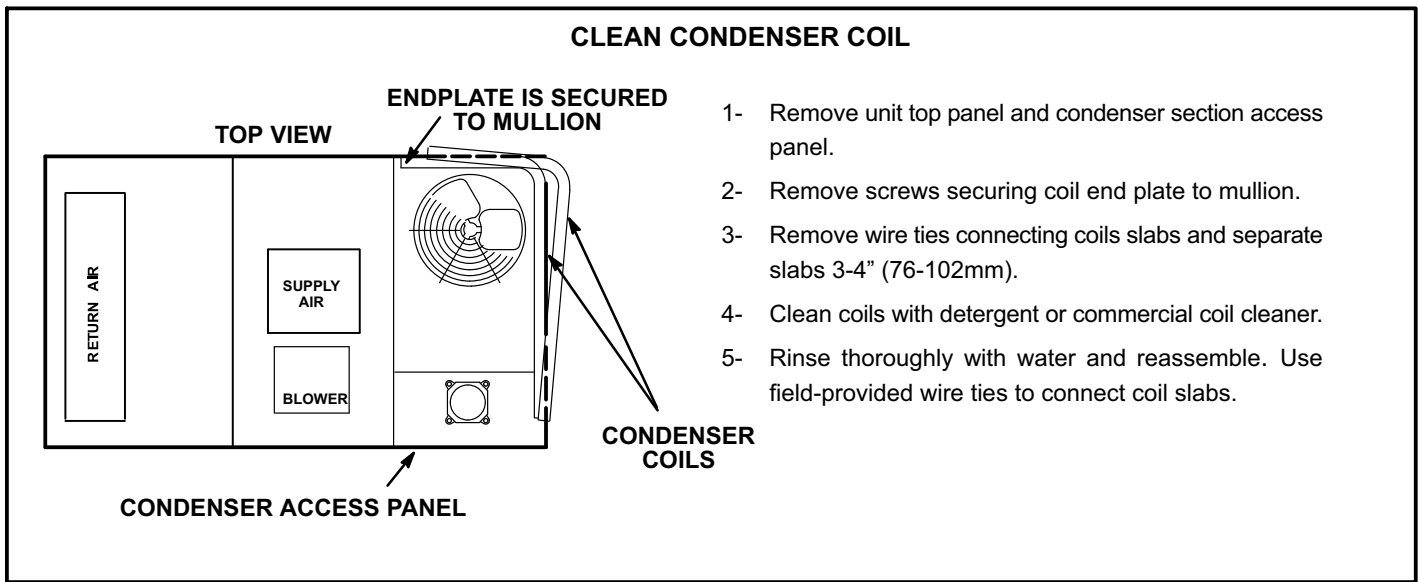

**FIGURE 15**

**D-Condenser Coil**

Clean condenser coil annually with detergent or commercial coil cleaner and inspect monthly during the cooling season.

Condenser coils are made of single and two formed slabs. On units with two slabs, dirt and debris may become trapped between the slabs. To clean between slabs, carefully separate coil slabs and wash them thoroughly. See figure 15. Flush coils with water following cleaning.

*Note - Remove all screws and gaskets prior to cleaning procedure and replace upon completion.*

**E-Supply Blower Wheel**

Annually inspect supply air blower wheel for accumulated dirt or dust. Turn off power before attempting to remove access panel or to clean blower wheel.

**VII-ACCESSORIES**

The accessories section describes the application of most of the optional accessories which can be factory- or field-installed to the LCH units.

**A-C1/T1CURB**

When installing the LCH units on a combustible surface for downflow discharge applications, the C1/T1CURB 8 inch, 14-inch, 18 inch or 24-inch height roof mounting frame is used. The roof mounting frames are recommended in all other applications but not required. If the LCH units are not mounted on a flat (roof) surface, they MUST be supported under all edges and under the middle of the unit to prevent sagging. The units MUST be mounted level within 1/16" per linear foot or 5mm per meter in any direction.

The assembled mounting frame is shown in figure 16. Refer to the roof mounting frame installation instructions for details of proper assembly and mounting. The roof mounting frame MUST be squared to the roof and level before mounting. Plenum system MUST be installed before the

unit is set on the mounting frame. Typical roof curbing and flashing is shown in figure 17. Refer to the roof mounting frame installation instructions for proper plenum construction and attachment.

**B-Transitions**

Optional supply/return transitions T1TRAN10AN1 is available for use with the LCH 3, 4 and 5 ton units and the T1TRAN20N-1 is available for the 6 ton units utilizing optional T1CURB roof mounting frames. Transition must be installed in the C1/T1CURB mounting frame before mounting the unit to the frame. Refer to the manufacturer's instructions included with the transition for detailed installation procedures.

**C-Supply and Return Diffusers**

Optional flush mount diffuser/return FD9-65 and FD11-95 and extended mount diffuser/return RTD9-65 and RTD11-95 are available for use with all LCH units. Refer to manufacturer's instructions included with transition for detailed installation procedures.

**D-Outdoor Air Dampers**

E1DAMP11A-1 manually operated outdoor air damper and E1DAMP21A-1 motorized outdoor air damper is available for LCH 3 and 4 ton units (see figure 18 or 19). E1DAMP11AT-1 manually operated outdoor air damper and E1DAMP21AT-1 motorized outdoor air damper is available for LCH 5 and 6 ton units. Both sets include the outdoor air hood. The manual damper is set at a fixed point to bring outside air into the building anytime the blower is operating. The motorized damper opens when the blower is operating and the thermostat is sending an occupied signal to the Unit Controller. If the thermostat signal is unoccupied, the motorized damper will not open. Washable filter supplied with the outdoor air dampers can be cleaned with water and a mild detergent. It should be sprayed with Filter Handicoater when dry prior to reinstallation. Filter Handicoater is R.P. Products coating no. 418 and is available as Part No. P-8-5069

**E-Economizer**  
**(Field- or Factory-Installed)**

Unit may contain an optional economizer. See figure 20.  
 The economizer uses outdoor air for free cooling when the temperature is suitable.

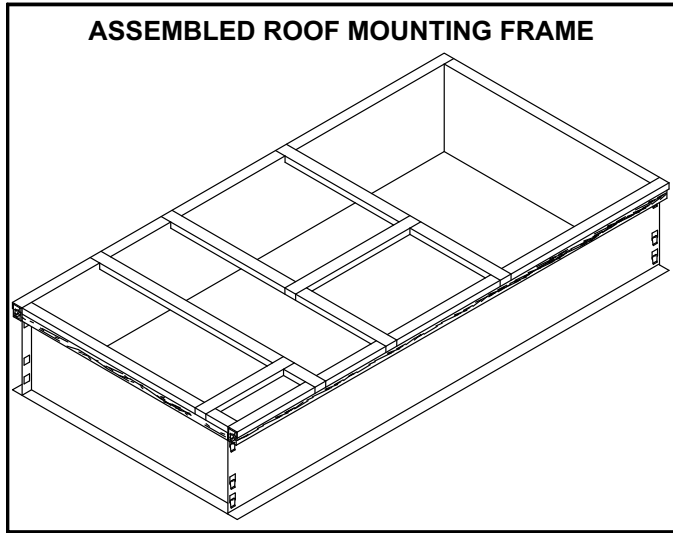

**FIGURE 16**

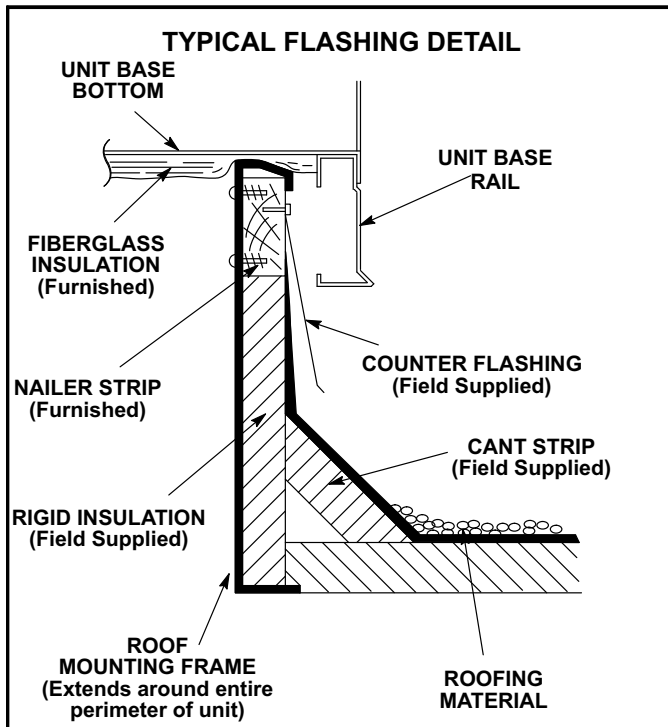

**FIGURE 17**

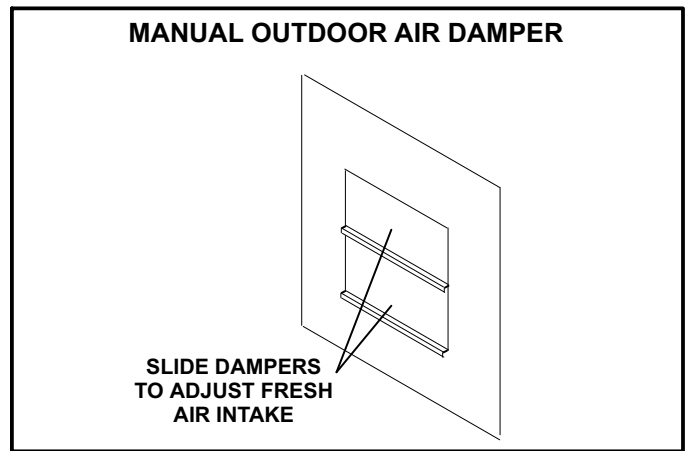

**FIGURE 18**

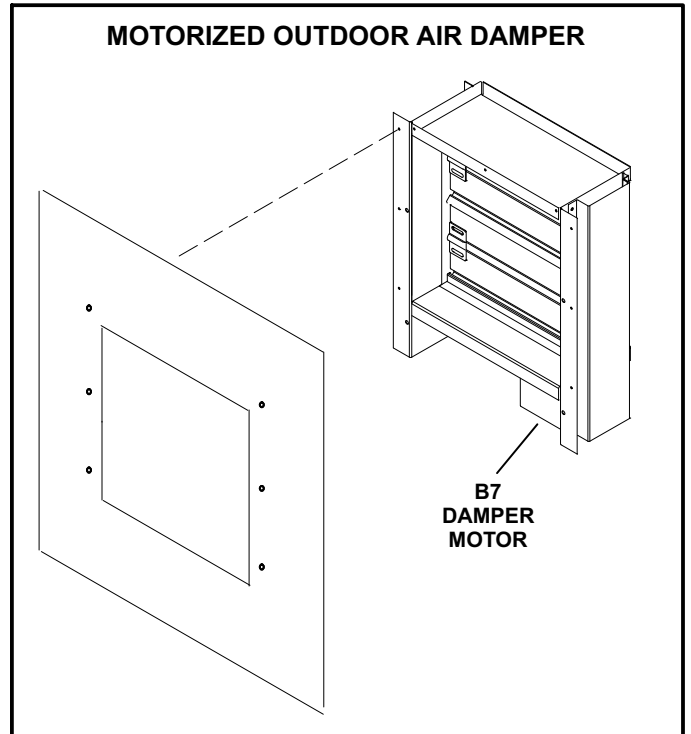

**FIGURE 19**

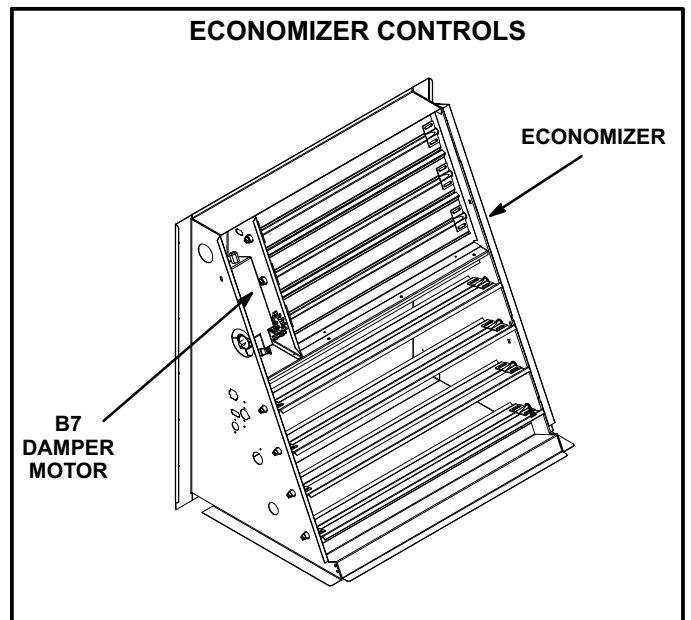

**FIGURE 20**

## Outdoor Air Suitability

Sensors or a global input are used to determine outdoor air suitability for free cooling. See table 23. Once outdoor air suitability is enabled, the factory-installed discharge air temperature sensor (RT6) is used to modulate dampers to 55°F (13°C) discharge air. See the Unit Controller guide to adjust this setpoint.

*NOTE - Free cooling can also be enabled by a message from an energy management system (EMS). These systems may require additional field-provided sensors; refer to manufacturers instructions.*

### Sensors

The appropriate sensors are provided when the economizer is factory-installed. When the economizer is field-installed, the ODE mode requires additional field-provided sensor(s). See table 23. The TEMP mode uses sensors provided with all units.

### DIP Switches

Damper mode is selected using the Unit Controller at unit start-up. Refer to the Unit Controller guide provided with each unit. See figure 21 for switch location and figure 22 for DIP switch settings.

## Outdoor Air Suitability LED

A yellow LED which is labeled OAS provides economizer status. A steady yellow LED indicates that outdoor air is suitable for free cooling. A flashing yellow OAS light indicates the IAQ sensor requires outdoor air. (A flashing yellow LED can also mean that the economizer dampers are open to bring in fresh air while a compressor is on.) If the economizer is already operating, a flashing yellow OAS light indicates the IAQ sensor requires more outdoor air than is suitable for free cooling. See figure 21.

### Optional Sensor

An optional IAQ sensor (A63) may be used to lower operating costs by controlling outdoor air based on CO<sub>2</sub> level or room occupancy (also called demand control ventilation or DCV). Damper minimum position can be set lower than traditional minimum air requirements; dampers open to traditional ventilation requirements when CO<sub>2</sub> level reaches DCV (IAQ) setpoint.

Refer to instructions provided with sensors for installation.

TABLE 23

Mode	DIP Switch	Outdoor air is suitable for free cooling when:
TEMP (offset)	TEMP	Outdoor air temperature (RT17) is less than return air temperature (RT16) minus the offset value (0 to 40°F).
TEMP (setpoint)	TEMP	Outdoor air temperature (RT17) is less than the setpoint value (41 to 70°F).
ENTH (differential)	ODE	Outdoor air enthalpy* (A7) is less than return air enthalpy (A62). Enthalpy setpoint potentiometer is set to DIFF
ENTH (setpoint)	ODE	Outdoor air enthalpy (A7) is less than enthalpy setpoint potentiometer position A, B, C, or D.
GLOBAL	GLO	Global input is energized by (P297-9). This setting is also used for outdoor air damper applications. Global input also brings on the blower. (This mode is NOT used when OAS signal is provided via network connection. GLO is only used when a 24VAC signal is used to energize the P297-9 GLO input.)

\*Enthalpy includes effects of both temperature and humidity.

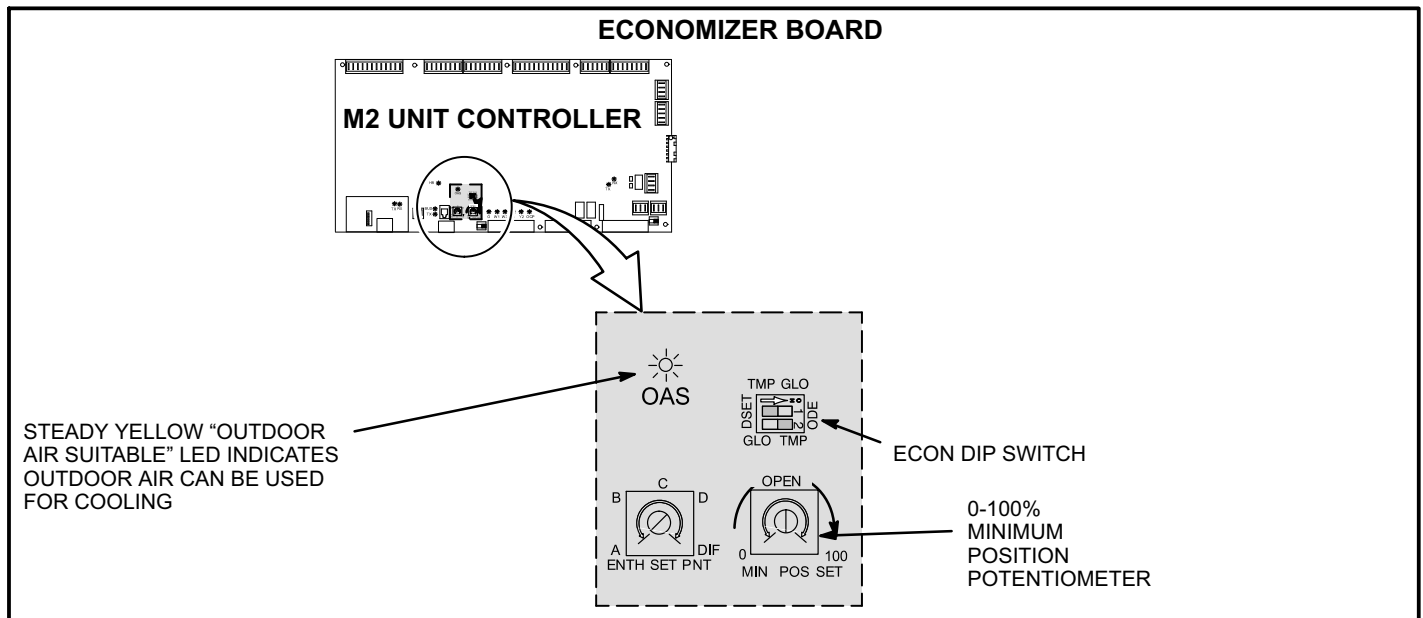

FIGURE 21

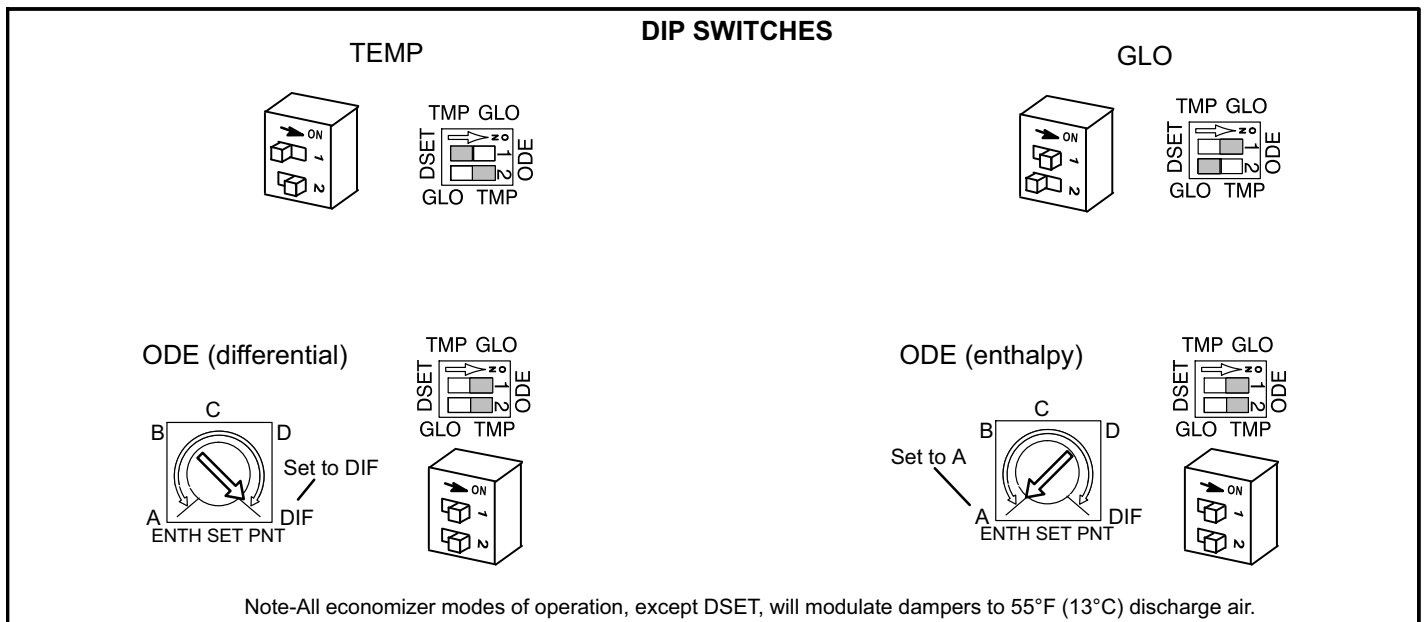

FIGURE 22

### Outdoor Air Damper and Economizer Operation

#### **DIRECT DRIVE AND BELT DRIVE SYSTEM OPERATION (3 THROUGH 5 TONS):**

*Note: Direct drive units feature ECM condenser fans that are staged to match the compressor's capacity. When the compressor is operating at first stage, the condenser fan is operating at low speed. The condenser fan switches to high speed when the compressor switches to second stage to match operation.*

#### **Modulating Outdoor Air Damper:**

*Damper minimum positions #1 and 2 are adjusted during unit setup to provide minimum fresh air requirements at the indicated supply fan speeds per ASHRAE 62.1.*

- Supply fan is off and the outdoor air damper is closed
- Supply fan is on low speed and the outdoor air damper is at minimum position 1
- Supply fan is on high speed and the outdoor air damper is at minimum position 2

#### **<sup>1</sup>Outdoor Air is Suitable**

*Note: When outdoor air is not suitable during the occupied time period, damper modulates to minimum position. When outdoor air is not suitable during the unoccupied time period, damper modulates closed.*

#### **Cooling - Thermostat or Zone Sensor Mode (Up to 3 stages Y1, Y2, Y3)**

##### Y1 demand:

1st-Compressor is off, supply fan is on low speed, economizer modulates (minimum to maximum open position) to maintain 55°F supply air temperature (default unit controller setting)

2nd-After 5 minutes (default unit controller setting), supply fan switches to high speed. Economizer continues modulating with supply fan on high speed to maintain 55°F supply air temperature

##### Y2 demand:

1st-Compressor is off, supply fan is on high speed, and economizer modulates to maintain 55°F supply air temperature

2nd-Economizer opens to maximum. If economizer stays at maximum open for 3 minutes (default unit controller setting) compressor is energized and operates at first stage while supply fan stays on high speed.

*<sup>1</sup>Outdoor air suitability is determined by the energy state of outdoor ambient (enthalpy or sensible) and its ability to achieve the desired free cooling effects. Outdoor air suitability can also be determined by a third party controller and provided to the RTU via a network connection.*

## Outdoor Air Damper and Economizer Operation (continued)

Y3 demand:

1st-Economizer is at maximum open and compressor operates at first stage. If economizer stays at maximum open for 3 minutes (default unit controller setting) compressor switches to second stage operation while supply fan stays on high speed

### **SINGLE STAGE UNIT OPERATION (6 TON):**

Modulating Outdoor Air Damper:

Damper minimum positions are adjusted during unit setup to provide minimum fresh air requirements at the indicated supply fan speeds per ASHRAE 62.1.

- Supply fan is off and the outdoor air damper is closed
- Supply fan is on and the outdoor air damper is at minimum position

### **<sup>1</sup>Outdoor Air is Suitable**

*Note: When outdoor air is not suitable during the occupied time period, damper modulates to minimum position. When outdoor air is not suitable during the unoccupied time period, damper modulates closed.*

Cooling - Thermostat or Zone Sensor (Up to 2 stages Y1, Y2)

Y1 demand:

1st-Compressor is off, supply fan is on, economizer modulates (minimum to maximum open position) to maintain 55°F supply air temperature (default unit controller setting)

Y2 demand:

1st-Economizer goes to maximum open position and if the damper stays open for three minutes (default unit controller setting) the compressor is energized.

### **F-Power Exhaust Relay K65 (power exhaust units)**

Power exhaust relay K65 is a DPDT relay with a 24VAC coil. K65 is used in all LCH units equipped with the optional power exhaust dampers. K65 is energized by the Unit Controller after the economizer dampers reach 50% open (adjustable). When K65 closes, exhaust fan B10 is energized.

### **G-Power Exhaust Fans**

E1PWRE10A available for LCH 3 and 4 ton units and ET1PWRE10N available for 5 and 6 ton units, provide exhaust air pressure relief. See figure 23 and installation instructions for more detail.

### **H-Optional UVC Lights**

The Healthy Climate® germicidal light emits ultraviolet (UVC) energy that has been proven effective in reducing microbial life forms (viruses, bacteria, yeasts, and molds) in the air.

UVC germicidal lamps greatly reduce the growth and proliferation of mold and other bio-aerosols (bacteria and viruses) on illuminated surfaces.

Germicidal lamps are NOT intended to be used for removal of active mold growth. Existing mold growth must be appropriately removed PRIOR to installation of the germicidal lamp.

Refer closely to UVC light installation instruction warnings when servicing units.

### **I-Smoke Detectors A171 and A172**

Photoelectric smoke detectors are a factory- or field-installed option. The smoke detectors can be installed in the supply air duct (A172), return air section (A171), or in both the supply duct and return air section.

### **J-Control Systems**

The A55 Unit Controller provides all control function for the rooftop unit. Default operation requires a standard room thermostat or direct digital controller (DDC). The A55 can also control the unit from a zone temperature sensor. The A55 Unit Controller is a network controller when daisy-chained to the L Connection® Network Control System. For ease of configuration, the A55 can be connected to a PC with Unit Controller PC software installed.

### **K-Dirty Filter Switch S27**

The dirty filter switch senses static pressure increase indicating a dirty filter condition. The switch is N.O. and closes at 1" W.C. (248.6 Pa) The switch is mounted in the supply air section on the evaporator coil seal.

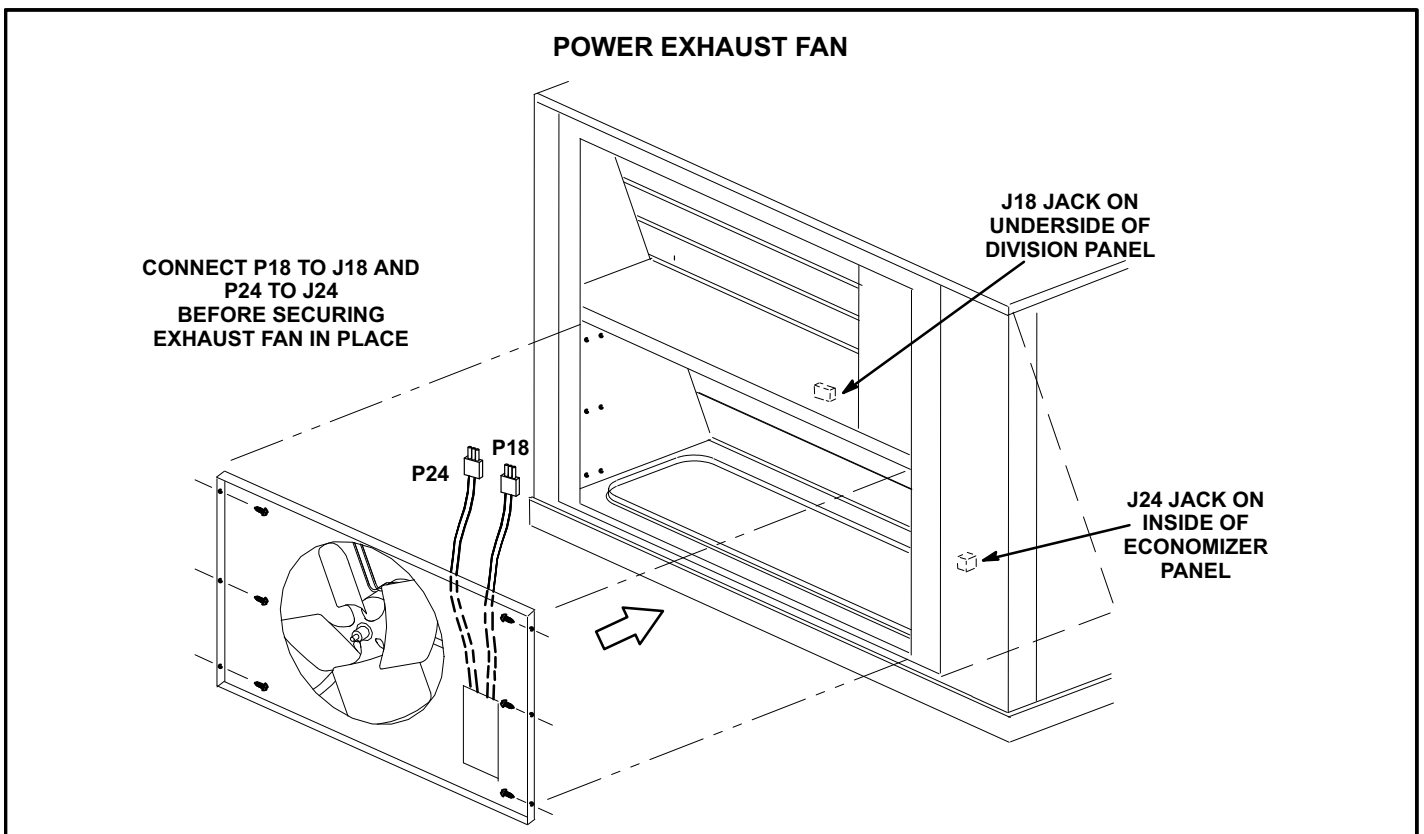

FIGURE 23

### L-Indoor Air Quality (CO<sub>2</sub>) Sensor A63

The indoor air quality sensor monitors CO<sub>2</sub> levels and reports the levels to the Unit Controller. The Unit Controller adjusts the economizer dampers according to the CO<sub>2</sub> levels. The sensor is mounted next to the indoor thermostat or in the return air duct. Refer to the indoor air quality sensor installation instructions for proper adjustment.

### M-Drain Pan Overflow Switch S149 (optional)

The overflow switch is used to interrupt cooling operation when excessive condensate collects in the drain pan. The N.O. overflow switch is controlled by K220 and DL46 relays, located in the unit control panel. When the overflow switch closes, 24VAC power is interrupted and after a five-second delay unit compressors are de-energized. Once the condensate level drops below the set level, the switch will open. After a five-minute delay the compressor will be energized.

### N-SunSource® Commercial Energy System

LCH036-072 packaged units are available with optional factory-installed components which make them SunSource® Solar-Ready. These specially-equipped units can be matched with solar modules and other optional equipment so that they can become part of a SunSource® Commercial Energy System.

Solar energy is first used to meet cooling/heating demands. When the unit is not operating, the system powers lighting, appliances and other electronic devices in the building. Any surplus power is sent back to the utility company for a possible credit (check your local utility company for policies).

The SunSource® Commercial Energy System consists of the following components:

- Emergence® 3-6 ton SunSource® Solar-Ready packaged electric/electric (LCH036-072) HVAC units.
- Solar modules (1 to 21 may be used to vary the amount of electricity generated on three-phase units; 15 modules maximum on single-phase units).
- Envoy Communications Gateway monitors solar power performance.

All components must be ordered separately.

Wiring runs from the roof-mounted solar modules to the unit. From there, power travels to the electrical service panel using the existing HVAC unit power wiring.







# LCH036/072 BELT DRIVE G, J, M, Y VOLTAGE UNIT DIAGRAM

24V POWER

NOTE - IF ANY WIRE IN THIS APPLIANCE IS REPLACED IT MUST BE REPLACED WITH WIRE OF LIKE SIZE, RATING, TERMINATION AND INSULATION THICKNESS

WARNING - ELECTRIC SHOCK HAZARD, CAN CAUSE INJURY OR DEATH. UNIT MUST BE GROUNDED IN ACCORDANCE WITH NATIONAL AND LOCAL CODES

DISCONNECT ALL POWER BEFORE SERVICING.

KEY	COMPONENT	DESCRIPTION
A55	CONTROL, MAIN PANEL LENNIX	
A169	PANEL, MOTOR CONTROL	
B1	COMPRESSOR 1	
B3	MOTOR, BLOWER	
B4	MOTOR, OUTDOOR FAN	
B10	MOTOR, EXHAUST FAN	
C1	CAPACITOR, OUTDOOR FAN 1	
C6	CAPACITOR, EXHAUST FAN	
CB8	CIRCUIT, BREAKER	
CB10	CIRCUIT BREAKER, MAIN DISCONNECT UNIT	
CB31	CIRCUIT BREAKER, TRANSFORMER T43	
HR1	HEATER, COMPRESSOR	
J3	JACK, ECONOMIZER BYPASS	
J11	JACK, GFI RECEPTACLE	
J18	JACK, EXHAUST FAN	
J24	JACK, EXHAUST FAN	
J47	JACK, OUTDOOR FAN	
J260	JACK, BLOWER,COMP TWO SPEED CONTROL	
J263	JACK, HIGH AND LOW PRESSURE SWITCHES	
J264	JACK, BLOWER DECK	
J265	JACK, CONTACTORS AND RELAYS	
J267	JACK, OUTDOOR FAN AREA	
J268	JACK, TRANSFORMER 1 POWER	
J269	JACK, HUMIDITROL	
J299B	JACK, HUMIDITROL INTERFACE	
K3,-1	CONTACTOR, BLOWER LOW	
K10,-1	RELAY, OUTDOOR FAN 1	
K37,-1	CONTACTOR, BLOWER HI	
K65-1,2	RELAY, EXHAUST FAN	
P3	P3	
P18	P18	
L14	VALVE, SOLENOID REHEAT COIL 1	
L34	SOLENOID, TWO STAGE	
P3	PLUG, ECONOMIZER BYPASS	
P18	PLUG, EXHAUST FAN	
P24	PLUG, EXHAUST FAN	
P47	PLUG, OUTDOOR FAN	
P259	PLUG, BLOWER ECM MOTOR	
P260	PLUG, BLOWER, COMP TWO SPEED CONTROL	
P263	PLUG, HIGH AND LOW PRESSURE SWITCHES	
P264	PLUG, BLOWER DECK	
P265	PLUG, CONTACTORS AND RELAYS	

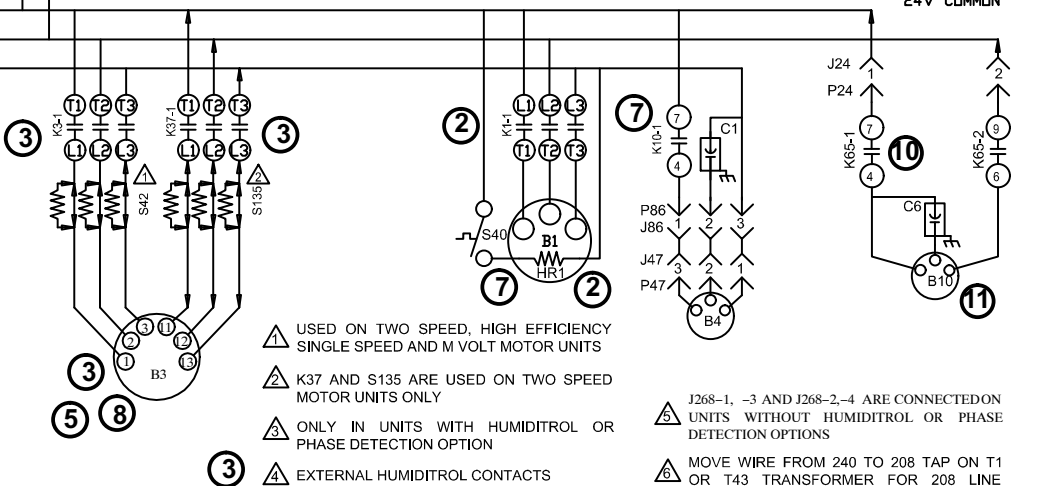
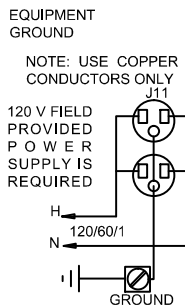
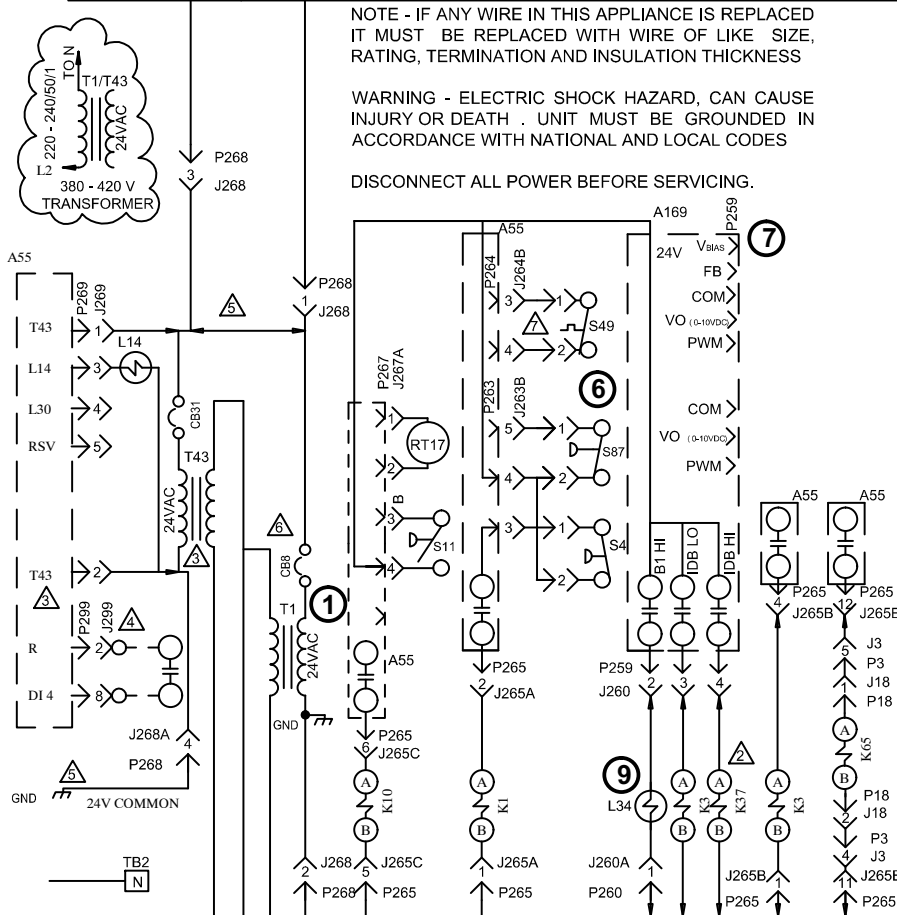

P267	PLUG, OUTDOOR FAN AREA
P268	PLUG, TRANSFORMERS
P269	PLUG, HUMIDITROL
P299	PLUG, SAFETY INTERFACE
RT17	SENSOR, OUTDOOR AIR
S4	SWITCH, LIMIT HI PRESS
S11	SWITCH, LOW PRESS, LOW AMBIENT KIT
S40	THERMOSTAT, CRANKCASE
S42	SWITCH, OVERLOAD RELAY BLOWER MOTOR
S48	SWITCH, DISCONNECT
S49	SWITCH, FREEZESTAT
S87	SWITCH, LOW PRESS, COMPRESSOR 1
S135	SWITCH, OVERLOAD BLOWER MOTOR
T1	TRANSFORMER, CONTROL
T43	TRANSFORMER, REHEAT

- ⚠️ USED ON TWO SPEED, HIGH EFFICIENCY SINGLE SPEED AND M VOLT MOTOR UNITS
- ⚠️ K37 AND S135 ARE USED ON TWO SPEED MOTOR UNITS ONLY
- ⚠️ ONLY IN UNITS WITH HUMIDITROL OR PHASE DETECTION OPTION
- ⚠️ EXTERNAL HUMIDITROL CONTACTS
- ⚠️ J268-1, -3 AND J268-2-4 ARE CONNECTED ON UNITS WITHOUT HUMIDITROL OR PHASE DETECTION OPTIONS
- ⚠️ MOVE WIRE FROM 240 TO 208 TAP ON T1 OR T43 TRANSFORMER FOR 208 LINE VOLTAGE APPLICATIONS
- ⚠️ S49 IS PART OF A 5VDC CIRCUIT

— DENOTES OPTIONAL COMPONENTS  
 — LINE VOLTAGE FIELD INSTALLED

WIRING DIAGRAM 03/10

COOLING

LCH, LGH 036S, 048S, 060S, 072H - G,J,M,Y

SECTION B REV. 4.0

Supersedes \_\_\_\_\_ New Form No. 537178-01

## LCH036/072 G, J, P, M, & Y Voltage Sequence of Operation

### Power:

1. Line voltage from unit disconnect energizes transformer T1. T1 provides 24VAC power to the A55 Unit Controller. A55 provides 24VAC to the unit cooling, heating and blower controls.
2. Line voltage from unit disconnect provides voltage to compressor crankcase heaters HR1 (through discharge line thermostat) and compressor contactor K1.  
A-Belt Drive Units - Voltage is distributed to blower motor contactors K3 (single & two speed systems) and K37 (two speed systems) and condenser fan relay K10.  
B-Direct Drive Units: Voltage is distributed directly to blower motor B3 and outdoor fan motor B4.

### Blower Operation:

The A55 Unit Controller receives a demand from thermostat terminal G. A55 energizes blower motor circuit follows:

3. Belt Drive:  
A-Single-Speed Systems (6-ton units): A55 energizes blower contactor K3 with 24VAC. N.O. contacts K3-1 close energizing blower B3.  
B-Two-Speed Systems (3-, 4-, and 5-ton units): A55, through motor control board A169, energizes blower low speed contactor K3 with 24VAC. N.O. contacts, K3-1, close energizing blower B3 on low speed (default). A55 can be programmed to direct 24VAC to blower high speed contactor K37 to energize blower B3 on high speed.
4. Direct Drive:  
A-A55, through motor control board A169, energizes blower B3 via programmed motor settings. Motor settings are field-adjustable.

### First-Stage Cooling

5. A55 Unit Controller receives a Y1 and G cooling demand and energizes blower B3 (low speed on two-speed belt and direct drive blowers).
6. After A55 proves n.c. low pressure switch S87, n.c. freezestat S49, and n.c. high pressure switch S4, compressor contactor K1 is energized.
7. N.O. contacts K1-1 close energizing the compressor B1. On two-speed systems (3, 4, and 5 tons) compressor is energized on low speed.  
A-Belt Drive Blowers - S11 n.o contacts close below 62°F. A55 energizes n.o. contacts K10-1 closed to start condenser fan B4.  
B-Direct Drive Blowers - S11 n.o. contact close below 62°F. A55, through motor control board A169, energizes outdoor fan motor B4 on low speed.

### Second-Stage Cooling

8. A55 receives a Y2 and G cooling demand and energizes blower B3 (high speed on two-speed belt and direct drive blowers).
9. On two-speed systems (3, 4, and 5 ton), A55 via motor control board A169, energizes compressor solenoid L34, switching compressor to high speed.  
A-Direct Drive Blowers - A55, via motor control board A169, energizes outdoor fan motor B3 on high speed.

### Power Exhaust Fan Operation

10. A55 receives a position feedback signal from the economizer damper motor and energizes exhaust fan relay K65 with 24VAC at 50% outside air damper open (adjustable).
11. N.O. contact K65-1 & 2 close, energizing exhaust fan motor B10.

# E1EH 7.5, 15, 22.5, 30 -G, J, M ELECTRIC HEAT

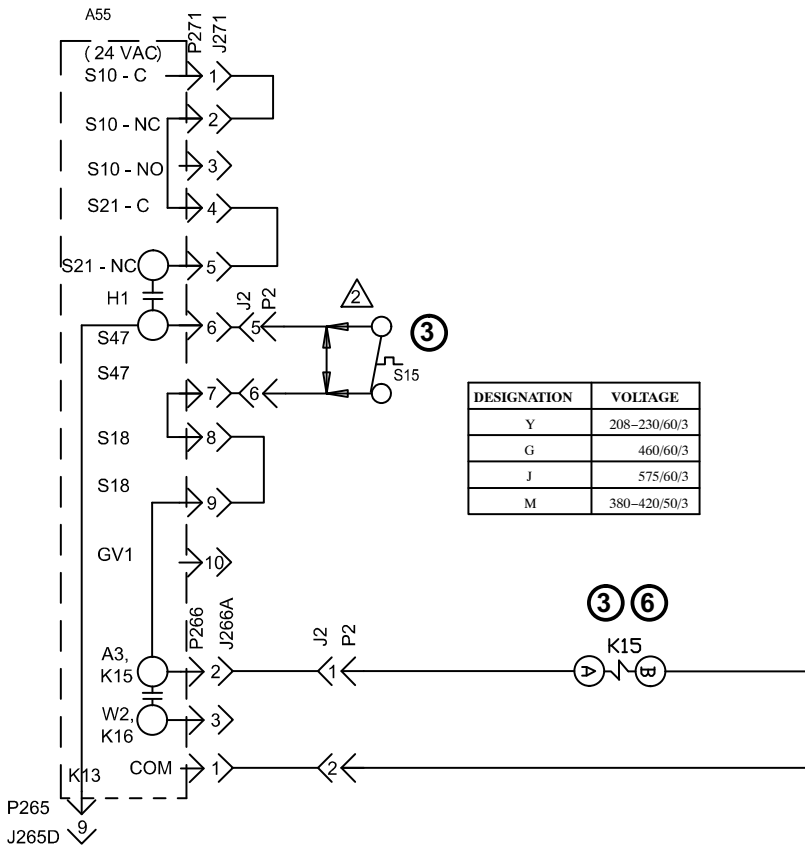

DESCRIPTION	
KEY	DESCRIPTION
A55	PANEL, MAIN
F3	FUSE, ELECTRIC HEAT
F4	FUSE, UNIT
HE -1	ELEMENT, ELECTRIC HEAT 1
J2	JACK, ELECTRIC HEAT
J265C	JACK, CONTACTOR RELAY
J266A	JACK, HEATING CONTROL STG 1
J271A,B	JACK, HEATING SENSORS STG 1
K15,-1	CONTACTOR, ELECTRIC HEAT 1
P2	PLUG, ELECTRIC HEAT
P265	PLUG, CONTACTOR RELAY
P266	PLUG, HEATING CONTROL
P271	PLUG, HEATING SENSORS STG 1
S15	SWITCH, LIMIT PRIMARY ELECTRIC HEAT
S20	SWITCH, LIMIT SECONDARY ELECTRIC HEAT 1
S157	SWITCH, LIMIT SECONDARY ELECTRIC HEAT 2
TB2	TERMINAL STRIP, UNIT

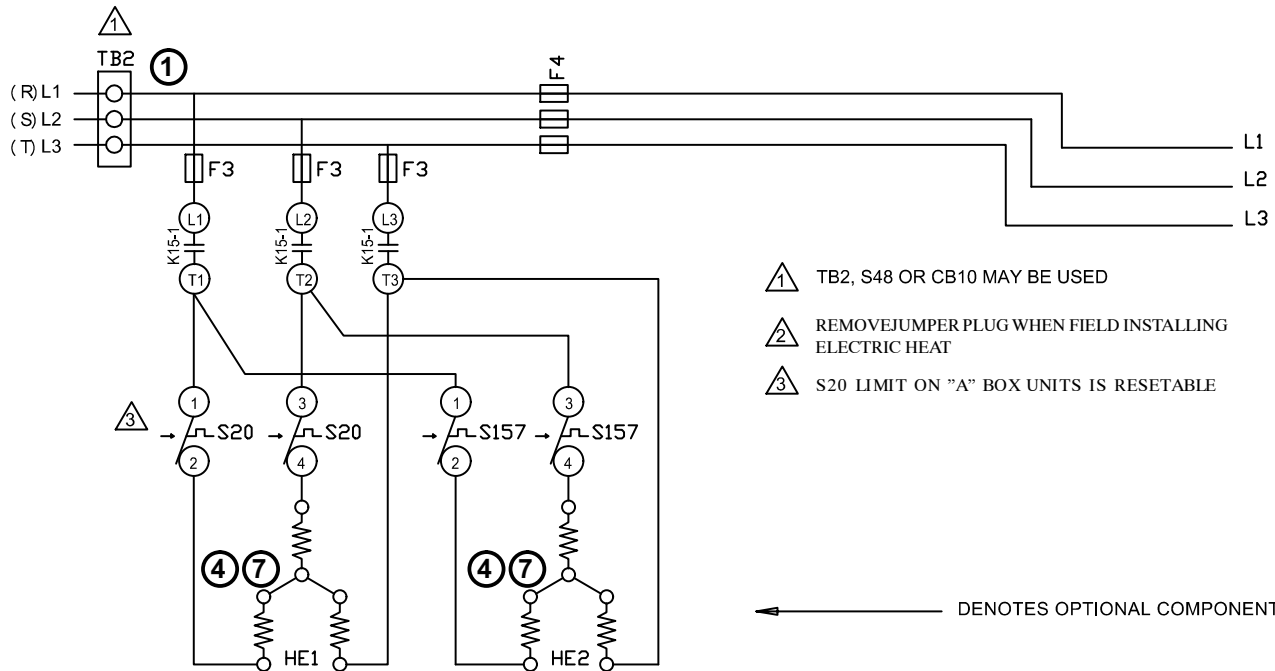

- ⚠️ TB2, S48 OR CB10 MAY BE USED
- ⚠️ REMOVE JUMPER PLUG WHEN FIELD INSTALLING ELECTRIC HEAT
- ⚠️ S20 LIMIT ON "A" BOX UNITS IS RESETTABLE

← DENOTES OPTIONAL COMPONENTS

			KW	HE1	HE2
072	060	066 - 048	7.5	7.5	
			15	15	
		22.5	15	7.5	
		30	15	15	

WIRING DIAGRAM		09/09
HEATING		
ELECTRIC HEAT FOR ENERGENCE™ E1EH - 7.5, 15, 22.5, 30 -G,J,M		
SECTION A		
Supersedes	New Form No. 537180-01	

# E1EH 7.5, 15, 22.5, 30 -Y ELECTRIC HEAT

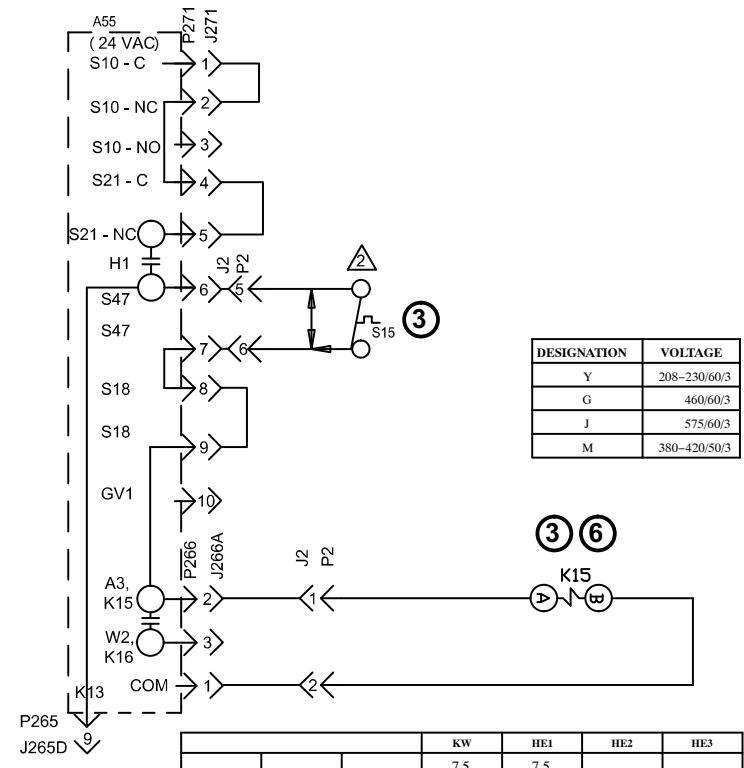

DESCRIPTION	
KEY	DESCRIPTION
A55	PANEL, MAIN
F3	FUSE, ELECTRIC HEAT
F4	FUSE, UNIT
HE -1	ELEMENT, ELECTRIC HEAT 1
HE -2	ELEMENT, ELECTRIC HEAT 2
HE -3	ELEMENT, ELECTRIC HEAT 3
J2	JACK, ELECTRIC HEAT
J265C	JACK, CONTACTOR RELAY
J266A	JACK, HEATING CONTROL STG 1
J271A,B	JACK, HEATING SENSORS STG 1
K15,-1	CONTACTOR, ELECTRIC HEAT 1
P2	PLUG, ELECTRIC HEAT
P265	PLUG, CONTACTOR RELAY
P266	PLUG, HEATING CONTROL
P271	PLUG, HEATING SENSORS STG 1
S15	SWITCH, LIMIT PRIMARY ELECTRIC HEAT
S20	SWITCH, LIMIT SECONDARY ELECTRIC HEAT 1
S157	SWITCH, LIMIT SECONDARY ELECTRIC HEAT 2
TB2	TERMINAL STRIP, UNIT

		KW	HE1	HE2	HE3	
072	060	036	7.5	7.5		
		- 048	15	15.0		
			22.5		15.0	7.5
			30		15.0	15.0

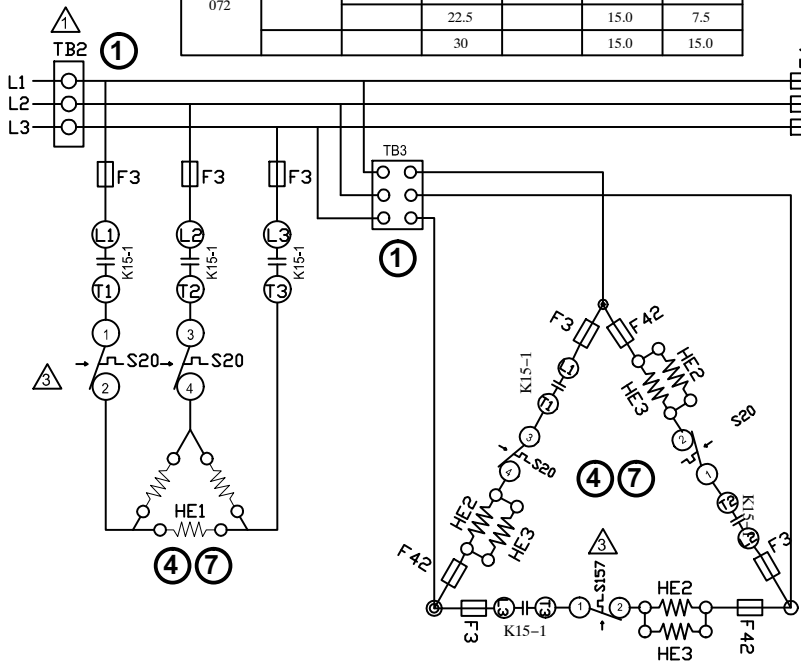

- ① TB2, S48 OR CB10 MAY BE USED
- ② REMOVE JUMPER PLUG WHEN FIELD INSTALLING ELECTRIC HEAT
- ③ S20 AND S157 LIMIT ON "A" BOX UNITS IS RESETTABLE

← DENOTES OPTIONAL COMPONENTS

WIRING DIAGRAM		09/09
HEATING		
ELECTRIC HEAT FOR EMERGENCY™		
E1EH - 7.5,15,22.5,30 - Y		
SECTION A		
Supersedes	New Form No.	
	537182-01	

# E1EH 7.5, 15, 22.5 -P ELECTRIC HEAT

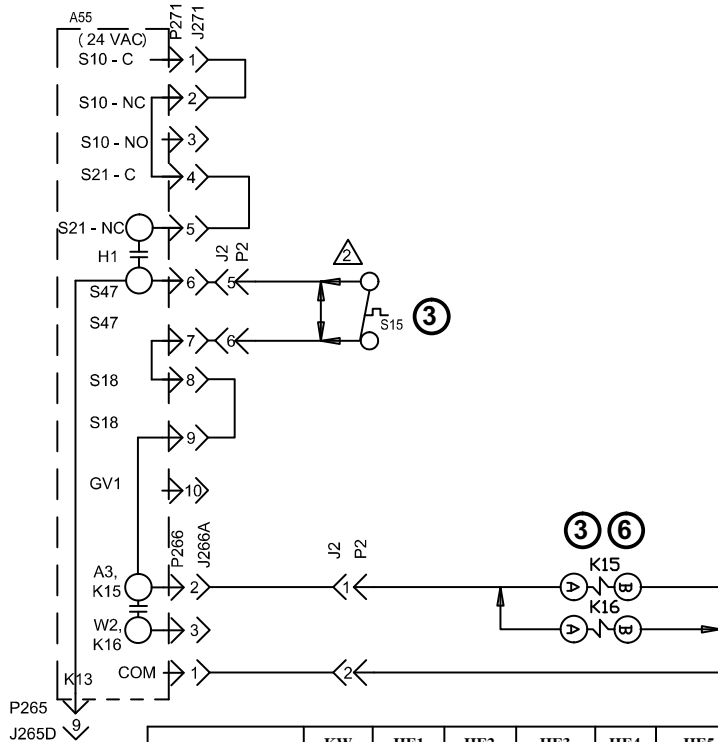

DESCRIPTION	
KEY	DESCRIPTION
A55	PANEL, MAIN
F3	FUSE, ELECTRIC HEAT
F4	FUSE, UNIT
HE -1	ELEMENT, ELECTRIC HEAT 1
HE -2	ELEMENT, ELECTRIC HEAT 2
HE -3	ELEMENT, ELECTRIC HEAT 3
HE -4	ELEMENT, ELECTRIC HEAT 4
HE -5	ELEMENT, ELECTRIC HEAT 5
HE -6	ELEMENT, ELECTRIC HEAT 6
J2	JACK, ELECTRIC HEAT
J265C	JACK, CONTACTOR RELAY
J266A	JACK, HEATING CONTROL STG 1
J271A,B	JACK, HEATING SENSORS STG 1
K15,-1	CONTACTOR, ELECTRIC HEAT 1
K16,-1	CONTACTOR, ELECTRIC HEAT 2
P2	PLUG, ELECTRIC HEAT
P7	PLUG, ELECTRIC HEAT SUB-BASE KIT
P265	PLUG, CONTACTOR RELAY
P266	PLUG, HEATING CONTROL
P271	PLUG, HEATING SENSORS STG 1
S15	SWITCH, LIMIT PRIMARY ELECTRIC HEAT
S20	SWITCH, LIMIT SECONDARY ELECTRIC HEAT 1
S157	SWITCH, LIMIT SECONDARY ELECTRIC HEAT 2
TB2	TERMINAL STRIP, UNIT

		KW	HE1	HE2	HE3	HE4	HE5	HE6
060	036 - 048	7.5	7.5					
		15		7.5	7.5			
		22.5				7.5	7.5	7.5

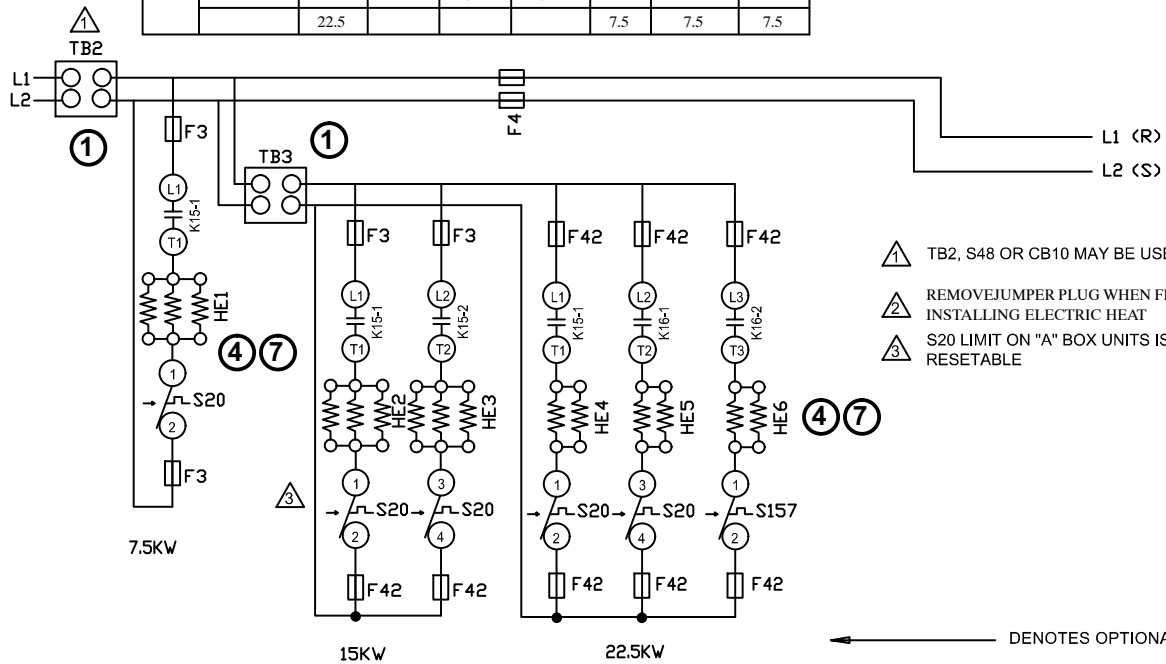

- ⚠ TB2, S48 OR CB10 MAY BE USED
- ⚠ REMOVE JUMPER PLUG WHEN FIELD INSTALLING ELECTRIC HEAT
- ⚠ S20 LIMIT ON "A" BOX UNITS IS RESETTABLE

← DENOTES OPTIONAL COMPONENTS

DESIGNATION	VOLTAGE
Y	208-230/60/3
G	460/60/3
J	575/60/3
M	380-420/50/3
P	208-230/60/1

WIRING DIAGRAM		09/09
HEATING		
ELECTRIC HEAT FOR ENERGENCE™		
E1EH - 7.5, 15, 22.5 - P		
SECTION A		
Supersedes	New Form No.	
	537181-01	

© 2009

Lennox Commercial

## Sequence of Operation -E1EH 7.5, 15, 22.5, 30 - G, J, M Voltage

### HEATING ELEMENTS:

- 1 - Terminal Strip TB2 is energized when the unit disconnect closes. TB2 supplies line voltage to electric heat elements HE1 and HE2. Elements are protected by fuse F3.

### FIRST STAGE HEAT:

- 2 - Heating demand initiates at W1 in thermostat.
- 3 - 24VAC is routed to the A55 Unit Controller. After A55 proves N.C. primary limit S15, the electric heat contactor K15 is energized. A55 energizes the blower and economizer.
- 4 - *7.5kW, 15kW units* - N.O. contacts K15-1 close energizing HE1.  
*22.5kW, 30kW units* - N.O. contacts K15-1 close energizing HE4, HE1 and HE2.

### END OF FIRST STAGE HEAT:

- 5 - Heating demand is satisfied. Terminal W1 in the thermostat is de-energized.
- 6 - Electric heat contactor K15 is de-energized.
- 7 - *7.5kW, 15kW units* - N.O. contacts K15-1 open de-energizing HE1.  
*22.5kW, 30kW units* - N.O. contacts K15-1 open de-energizing HE1 and HE2.

## Sequence of Operation -E1EH 7.5, 15, 22.5, 30 - Y Voltage

### HEATING ELEMENTS:

- 1 - Terminal Strip TB2 is energized when the unit disconnect closes. TB2 supplies line voltage to electric heat elements HE1 and TB3. TB3 supplies line voltage to HE2 and HE3. Elements are protected by fuses F3 and or F42.

### FIRST STAGE HEAT:

- 2 - Heating demand initiates at W1 in thermostat.
- 3 - 24VAC is routed to the A55 Unit Controller. After A55 proves N.C. primary limit S15, the electric heat contactor K15 is energized. A55 energizes the blower and economizer.
- 4 - *7.5kW and 15kW units* - N.O. contacts K15-1 close energizing HE1.  
*22.5kW and 30kW units* - N.O. contacts K15-1 close energizing HE2 and HE3.

### END OF FIRST STAGE HEAT:

- 5 - Heating demand is satisfied. Terminal W1 in the thermostat is de-energized.
- 6 - Electric heat contactor K15 is de-energized.
- 7 - *7.5kW, 15kW units* - N.O. contacts K15-1 open de-energizing HE1.  
*22.5kW, 30kW units* - N.O. contacts K15-1 open de-energizing HE2 and HE3.

## Sequence of Operation -E1EH 7.5, 15, 22.5, 30 - P Voltage

### HEATING ELEMENTS:

- 1 - Terminal Strip TB2 is energized when the unit disconnect closes. TB2 supplies line voltage to electric heat elements HE1 and TB3. TB3 supplies line voltage to HE2 through HE6. Elements are protected by fuses F3 and F42.

### FIRST STAGE HEAT:

- 2 - Heating demand initiates at W1 in thermostat.
- 3 - 24VAC is routed through A55 Unit Controller. After A55 proves N.C. primary limit S15, the electric heat contactor K15 (and K16 for 22.5kW units) is energized. A55 energizes blower and economizer.
- 7 - *7.5kW units* - N.O. contacts K15-1 close energizing HE1.  
*15kW units* - N.O. contacts K15-1 & 2 close energizing HE2 and HE3.  
*22.5kW units* - N.O. contacts K15-1, K16-1 and K16-2 close energizing HE4, HE5 and HE6.

### END OF FIRST STAGE HEAT:

- 5 - Heating demand is satisfied. Terminal W1 in the thermostat is de-energized.
- 6 - Electric heat contactor K15 (and K16 on 22.5kW units) is de-energized.
- 7 - *7.5kW units* - N.O. contacts K15-1 open de-energizing HE1.  
*15kW units* - N.O. contacts K15-1 & 2 open de-energizing HE2 and HE3.  
*22.5kW units* - N.O. contacts K15-1, K16-1 and K16-2 open de-energizing HE4, HE5 and HE6.

# ELECTRONIC OR ELECTROMECHANICAL THERMOSTAT

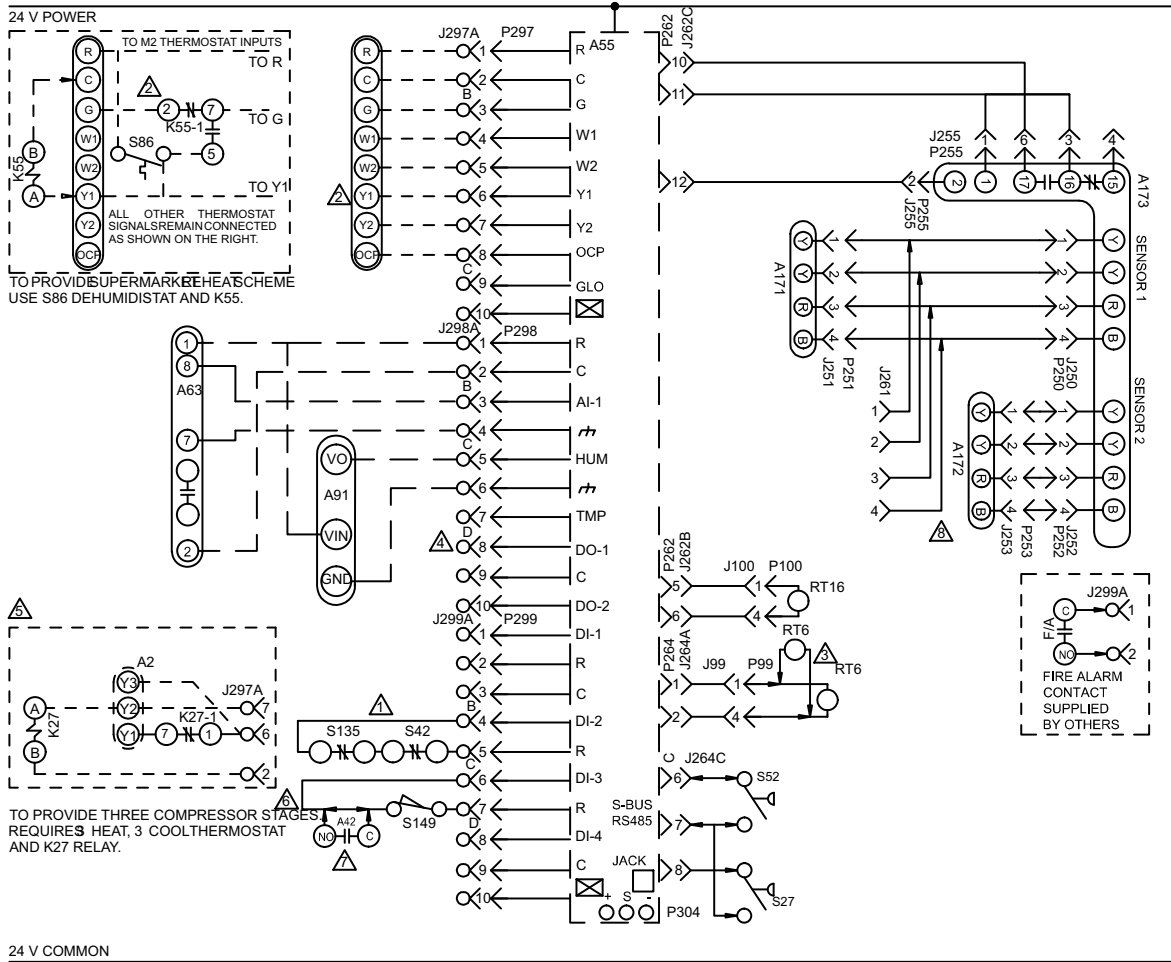

KEY	DESCRIPTION COMPONENT
A2	SENSOR, ELECTRONIC THERMOSTAT
A42	MONITOR, PHASE PROTECTOR
A55	PANEL, MAIN
A63	SENSOR, CO2 (IAQ) OPTIONAL
A91	SENSOR, HUMIDITY
A171	SENSOR ONE, SMOKE, RETURN AIR
A172	SENSOR TWO, SMOKE, SUPPLY AIR
A173	MODULE, CONTROL SMOKE DETECTION
J99	JACK, RT16 RETURN AIR SENSOR
J100	JACK, RT6 SUPPLY AIR SENSOR
J250	JACK, SMOKE DETECTOR ONE
J251	JACK, SMOKE DETECTOR ONE
J252	JACK, SMOKE DETECTOR TWO
J253	JACK, SMOKE DETECTOR TWO
J255	JACK, MODULE, CONTROL SMOKE DETECTION
J261	JACK, SUPPLY SMOKE DETECTOR JUMPER
J262	JACK, ECONOMIZER
J264	JACK, BLOWER DECK
J297	JACK, THERMOSTAT - DDC INTERFACE
J298	JACK, IAQ INTERFACE
J299	JACK, SAFETY INTERFACE
K27,-1	RELAY, TRANSFER
K55,-1	RELAY, BLOWER
P99	PLUG, RT16 RETURN AIR SENSOR
P100	PLUG, RT6 SUPPLY AIR SENSOR
P250	PLUG, SMOKE DETECTOR ONE
P251	PLUG, SMOKE DETECTOR ONE
P252	PLUG, SMOKE DETECTOR TWO
P253	PLUG, SMOKE DETECTOR TWO
P255	PLUG, MODULE, CONTROL SMOKE DETECTION
P262	PLUG, ECONOMIZER

P264	PLUG, BLOWER DECK
P297	PLUG, THERMOSTAT - DDC INTERFACE
P298	PLUG, IAQ INTERFACE
P299	PLUG, SAFETY INTERFACE
P304	PLUG, SYS BUS
RT6	SENSOR, SUPPLY AIR TEMP
RT16	SENSOR, RETURN AIR TEMP
S27	SWITCH, FILTER
S52	SWITCH, AIRFLOW
S42	SWITCH, OVERLOAD RELAY BLOWER MOTOR
S86	SWITCH, DEHUMIDISTAT
S135	SWITCH, OVERLOAD RELAY BLOWER MOTOR
S149	SWITCH, OVERFLOW

- ⚠ FOR MOTORS WITH S42 AND S135 EXTERNAL OVERLOAD LESS INVERTER, SEE INVERTER WITH BY PASS FOR S42 HOOK UP
- ⚠ USE S86 DEHUMIDISTAT AND K55 FOR OPTIONAL SUPERMARKET REHEAT SCHEME. M2 PARAMETERS NEED TO BE MODIFIED UNDER HEATING/ENLOR VIA UCSOFTWARE FOR SIMULTANEOUS HEATING AND COOLING.
- ⚠ REMOTE LOCATION OF RT6
- ⚠ P298-8 (DO-1) IS SERVICE RELAY OUTPUT (24VAC) IF USED CONNECT TO AN INDICATOR LIGHT
- ⚠ THERMOSTAT HOOKUP FOR PROGRAMMABLE CONFIGURATION OF THE M2 BOARD (A55).
- ⚠ M2 SETTINGS MUST BE MODIFIED WHEN A42, S42, S52, S135 OR S149 ARE INSTALLED
- ⚠ A42 USED ON 036 THROUGH 72 UNITS ONLY
- ⚠ CONNECT A172 SENSOR TO J261 ON SUPPLY AIR SMOKE DETECTOR ONLY
- ➡ DESIGNATES OPTIONAL WIRING CLASS II FIELD WIRING

	WIRING DIAGRAM	11/09
<b>ACCESSORIES</b>		
ELECTRONIC OR ELECTROMECHANICAL THERMOSTAT FOR EMERGENCE™		
SECTION C		REV. 3.0
Supersedes	New Form No. 537108-01	

**POWER:**

- A55 Unit Controller, located in the main control box, supplies thermostat components with 24VAC.

**OPERATION:**

- A55 receives data from the electronic thermostat A2 (Y1, Y2, W1, W2, G) and energizes the appropriate components for heat or cool demand.

# ECONOMIZER

KEY	DESCRIPTION	COMPONENT
A7	SENSOR, SOLID STATE ENTHALPY	
A130	CONTROL, ERS	
A55	CONTROL, MAIN PANEL LENNOX	
A62	SENSOR, ENTHALPY INDOOR	
A72	CONTROL, REMOTE MIN POS (OPT)	
B7	MOTOR, DAMPER ECONOMIZER	
B43	MOTOR, EXHAUST DAMPER	
J3	JACK, UNIT ECONOMIZER	
J104	JACK, SENSOR OUTDOOR ENTHALPY	
J105	JACK, SENSOR RETURN AIR ENTHALPY	
J153	JACK, ENTHALPY / DAMPER MOTOR	
J193	JACK, ENTHALPY SENSOR	
J298A	JACK, IAQ INTERFACE	
J262A	JACK, DAMPER MOTOR	
J262B	JACK, ENTHALPY SENSORS	
P3	PLUG, ECONOMIZER BYPASS	
P153	PLUG, ENTHALPY / DAMPER MOTOR	
P193	PLUG, ENTHALPY SENSOR	
P262	PLUG, ECONOMIZER OUTPUT	
S118	THERMOSTAT, DESICANT DEFROST	
S174	SWITCH, EXHAUST DAMPER	

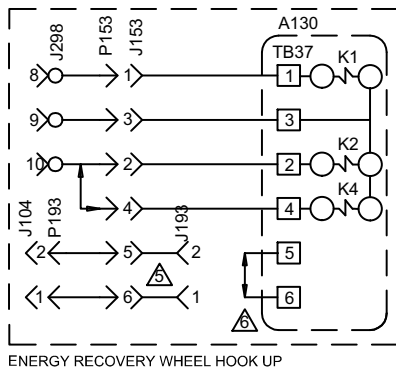
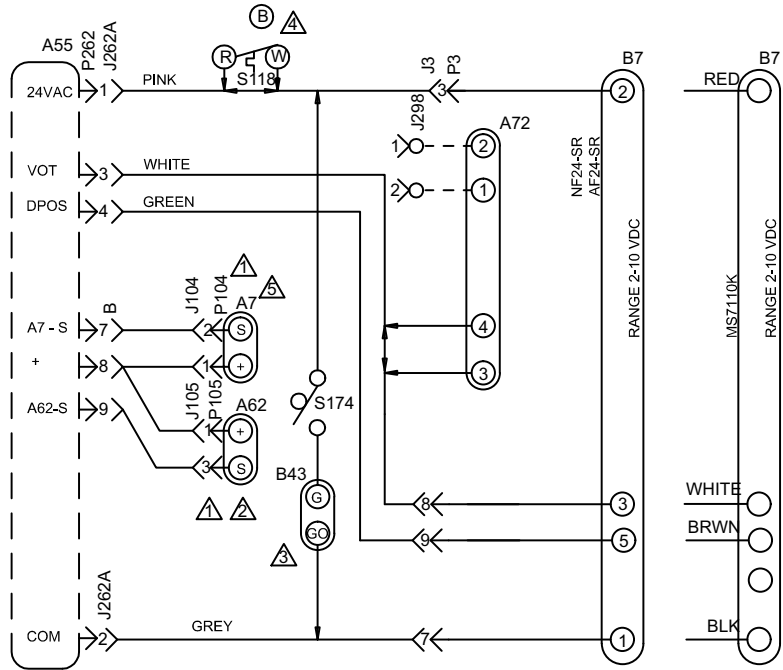

- ⚠️ DELETE A7 AND A62 (IF USED) FOR EITHER GLOBAL ENTHALPY OR SENSIBLE TEMPERATURE CONTROL
- ⚠️ FOR UNIT DIFFERENTIAL ENTHALPY CONTROL, ADD A62 RETURN AIR ENTHALPY SENSOR
- ⚠️ OPTIONAL EXHAUST DAMPER ACTUATOR TO HOLD EXHAUST DAMPER CLOSED WHEN OUTSIDE AIR DAMPER IS CLOSED
- ⚠️ S118 USED ON 35 TO 50 TON EMERGENCE UNITS WITH ENERGY RECOVERY WHEEL (ERW)
- ⚠️ REPOSITION A7 ENTHALPY SENSOR FROM ROOFTOP UNIT ECONOMIZER INTO INTAKE HOOD OF THE ERW ROOFTOP UNIT
- ⚠️ REMOVE JUMPER WHEN INSTALLING OPTIONAL LOW AMBIENT SWITCH

NOTE- THIS DIAGRAM USED ONLY WHEN ECONOMIZER OR MOTORIZED OUTDOOR AIR DAMPERS ARE INSTALLED.

————— DESIGNATES OPTIONAL WIRING  
 - - - - - CLASS II FIELD WIRING

WIRING DIAGRAM		09/09
<b>ACCESSORIES</b>		
ENERGENCE™ SERIES ECONOMIZER AND MOTORIZED OAD PIVOTING WHEEL ENERGY RECOVERY SYSTEM OPTION		
SECTION D		
Supersedes	New Form No. 537189-01	

© 2009

Lennox Commercial

## SEQUENCE OF OPERATION

### POWER:

1. A55 Unit Controller energizes the economizer components with 24VAC.

### OPERATION:

2. Sensor(s), a global input, or a communication signal communicates to A55 when to power the damper motor B7.
3. A55 supplies B7 with 0 - 10 VDC to control the positioning of economizer.
4. The damper actuator provides 2 to 10 VDC position feedback.