

CBX25UH (-10) Series

Table of Contents



Unit Dimensions 2

Specifications / Electrical Data 3

Model Number Information 4

Blower Data 4

Application 6

Unit Components 6

Optional ECB25 Electric Heat 7

Configuration Modification 10

Electrical Connections 16

Wiring Diagrams 18

Start-Up Operations 20

Sequence of Operations 21

Performance Checklists 22

The CBX25UH units are high-efficiency air handlers. Several models are available in sizes ranging from 1-1/2 through 5-tons. The CBX25UH is designed for HFC-410A refrigerant.

CBX25UH series units are designed to be matched with either a 13 SEER air conditioner or heat pump, but can be matched with other air conditioners or heat pumps as noted in the rating information. See Product Specification bulletin.

This air handler is designed for indoor installation only. As shipped, the unit is ready for installation in either upflow or horizontal left-hand. Field modifications are required for right-hand air discharge applications. Electric heat, down flow air discharge application kits, air filters and other various accessories are available and listed in the *CBX25UH Product Specification bulletin* for ordering.

All units come with a factory installed check/expansion valve.

Information contained in this manual is intended for use by experienced licensed HVAC service technicians only. All specifications are subject to change. Procedures outlined in this manual are presented as a recommendation only and do not supersede or replace local or state codes.

⚠ WARNING

The State of California has determined that this product may contain or produce a chemical or chemicals, in very low doses, which may cause serious illness or death. It may also cause cancer, birth defects, or reproductive harm.

⚠ WARNING

Improper installation, adjustment, alteration, service or maintenance can cause personal injury, loss of life, or damage to property.

Installation and service must be performed by a licensed professional installer (or equivalent) or a service agency.

⚠ CAUTION

As with any mechanical equipment, contact with sharp sheet metal edges can result in personal injury. Take care while handling this equipment and wear gloves and protective clothing.

⚠ IMPORTANT

The Clean Air Act of 1990 bans the intentional venting of refrigerant (CFCs, HCFCs and HFCs) as of July 1, 1992. Approved methods of recovery, recycling or reclaiming must be followed. Fines and/or incarceration may be levied for noncompliance.

CBX25UH Unit Dimensions – Upflow – inches (mm)

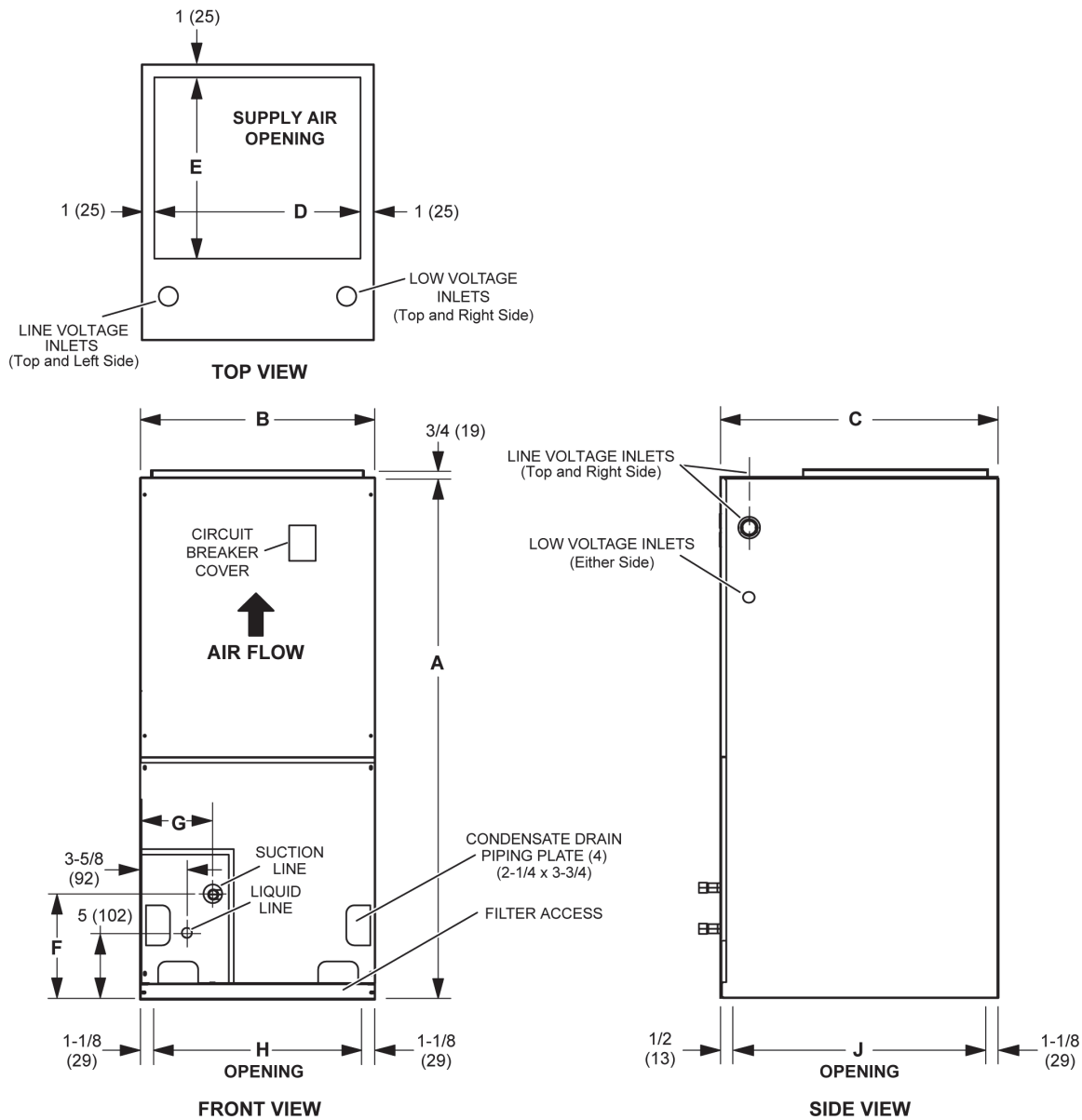

Dimension	018		024		030		036		042		048-060	
	in.	mm	in.	mm	in.	mm	in.	mm	in.	mm	in.	mm
A	38	965	40-1/2	1029	43	1092	52-1/2	1334	48	1219	52-1/2	1334
B	15	381	18-1/2	470	18-1/2	470	21-7/8	556	21-7/8	556	21-7/8	556
C	22	559	22	559	22	559	22	559	26-1/4	667	26-1/4	667
D	13	330	16-1/2	419	16-1/2	419	19-7/8	505	19-7/8	505	19-7/8	505
E	14-1/2	368	14-1/2	368	14-1/2	368	14-1/2	368	18-3/4	476	18-3/4	476
F	8	203	8	203	8	203	8	203	9-1/4	235	9-1/4	235
G	5-5/8	143	5-5/8	143	5-5/8	143	5-5/8	143	4-1/2	114	4-1/2	114
H	12-3/4	324	16-1/4	413	16-1/4	413	19-5/8	498	19-5/8	498	19-5/8	498
J	20-3/8	518	20-3/8	518	20-3/8	518	20-3/8	518	24-5/8	625	24-5/8	625

NOTE - Unit is shipped configured for horizontal left-hand air discharge. Unit may be converted to horizontal right-hand air discharge by repositioning horizontal drain pan. Dimensions remain the same in all configurations.

Specification and Electrical Data

SPECIFICATION

General Data	Model Number	CBX25UH-018	CBX25UH-024	CBX25UH-030	CBX25UH-036
		Nominal tonnage	1.5	2	2.5
Connections	Suction/Vapor line (o.d.) - in. sweat	3/4	3/4	3/4	7/8
	Liquid line (o.d.) - in. sweat	3/8	3/8	3/8	3/8
	Condensate - in. fpt	(2) 3/4	(2) 3/4	(2) 3/4	(2) 3/4
Indoor Coil	Net face area - ft. ²	3.11	3.56	4.00	4.89
	Tube outside diameter - in.	3/8	3/8	3/8	3/8
	Number of rows	3	3	3	3
	Fins per inch	14	14	14	14
Blower	Wheel nominal diameter x width - in.	9 x 6	9 x 6	10 x 8	10 x 8
	Blower motor output - hp	1/3	1/3	1/3	1/3
¹ Filters	Size of filter - in.	12 x 20 x 1	15 x 20 x 1	15 x 20 x 1	18 x 20 x 1
Shipping Data -1 package - lbs.		109	127	133	163
ELECTRICAL DATA					
Voltage - 1 phase (60 hz)		208/240V	208/240V	208/240V	208/240V
² Maximum over-current protection (unit only)		15	15	15	15
³ Minimum circuit ampacity (unit only)		2.0	2.0	2.4	2.5
Blower Motor Full Load Amps		1.6	1.6	1.9	2.0

SPECIFICATIONS

General Data	Model Number	CBX25UH-042	CBX25UH-048	CBX25UH-060
		Nominal tonnage	3.5	4
Connections	Suction/Vapor line (o.d.) - in. sweat	7/8	7/8	7/8
	Liquid line (o.d.) - in. sweat	3/8	3/8	3/8
	Condensate - in. fpt	(2) 3/4	(2) 3/4	(2) 3/4
Indoor Coil	Net face area - ft. ²	5.83	7.00	7.00
	Tube outside diameter - in.	3/8	3/8	3/8
	Number of rows	3	3	3
	Fins per inch	14	14	14
Blower	Wheel nominal diameter x width - in.	12 x 8	11 x 9	12 x 9
	Blower motor output - hp	1/3	1/2	1/2
¹ Filters	Size of filter - in.	18 x 24 x 1	18 x 24 x 1	18 x 24 x 1
Shipping Data -1 package - lbs.		168	186	186
ELECTRICAL DATA				
Voltage - 1 phase (60 hz)		208/240V	208/240V	208/240V
² Maximum overcurrent protection (unit only)		15	15	15
³ Minimum circuit ampacity (unit only)		2.4	4.9	4.9
Blower Motor Full Load Amps		1.9	3.9	3.9

¹ Disposable filter.

² HACR type circuit breaker or fuse.

³ Refer to National or Canadian Electrical Code manual to determine wire, fuse and disconnect size requirements. Use wires suitable for at least 167°F.

Model Number Identification

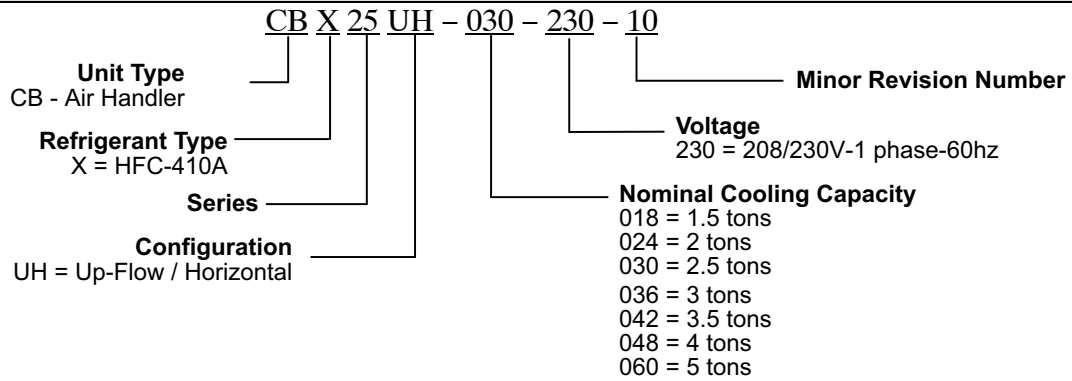

Blower Data

The cooling blower speed is factory configured to provide correct airflow for an outdoor unit that matches the cooling capacity rating of the air handler.

CHANGE BLOWER SPEED

If the outdoor unit is smaller than the maximum cooling capacity rating for the air handler, the cooling blower speed may need to be changed. Refer to blower performance chart, table 1 on page 5. Use figure 1 on page 4 as a illustrated guide to the following procedure:

1. Disconnect all power supplies.
2. Remove the air handler access panel.
3. A blower relay harness is used to connect blower relay terminals **2** and **5**. The third connector is mated to the **BLUE (MED)** wire.
4. Disconnect the **BLUE (MED)** wire connection.

5. Determine the required blower speed and connect either the blower lead **RED (LO)** or **BLACK (HI)** to the blower relay harness.

NOTE — Reuse the factory-installed plastic cap on the connector that is not used.

6. Replace all panels.
7. Reconnect power.

⚠ CAUTION

Electrostatic discharge can affect electronic components. Take precautions during unit installation and service to protect the unit's electronic controls. Precautions will help to avoid control exposure to electrostatic discharge by putting the unit, the control and the technician at the same electrostatic potential. Neutralize electrostatic charge by touching hand and all tools on an unpainted unit surface before performing any service procedure.

BLOWER RELAY

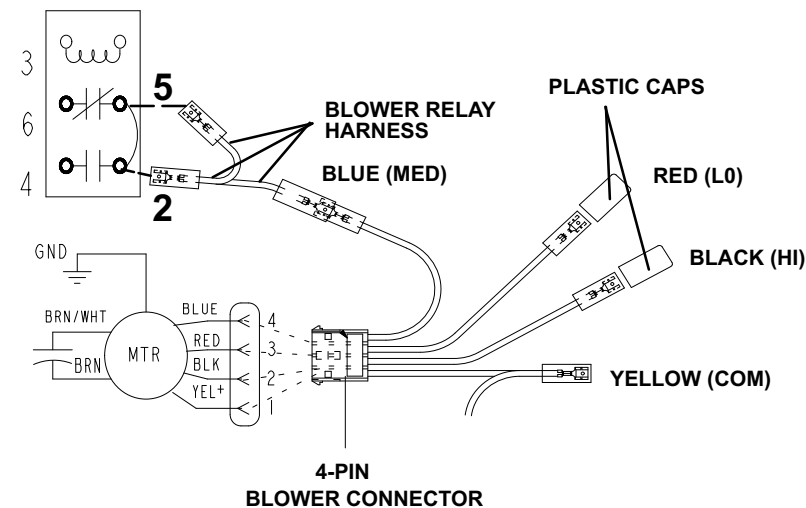

Figure 1. Changing Blower Speed

NOTE — Refer to wiring diagram located on the unit access panel (or figure 1 above) and blower performance (table 1).

- All air data measured external to unit with 1 inch non-pleated air filter in place.
- All factory settings are medium speed except the -48 which is set to low speed from the factory.
- All data given while air handler is operating with a dry DX coil.

Table 1. Blower Performance (3-Speed PSC) - 240V (CFM @ ESP. - in. W. C.)

Air Handler Model	Blower Speed	.10" WC	.20" WC	.30" WC	.40" WC	.50" WC
18	Low (Red)	510	495	475	420	325
	Med (Blue)	670	650	630	595	505
	High (Black)	905	865	820	770	705
24	Low (Red)	630	625	615	610	580
	Med (Blue)	885	875	850	820	780
	High (Black)	1130	1100	1070	1010	950
30	Low (Red)	900	865	830	780	740
	Med (Blue)	1075	1060	1030	985	940
	High (Black)	1240	1210	1170	1135	1085
36	Low (Red)	1075	1040	1000	950	900
	Med (Blue)	1300	1250	1205	1145	1085
	High (Black)	1510	1450	1390	1320	1245
42	Low (Red)	1325	1315	1300	1275	1225
	Med (Blue)	1490	1465	1440	1395	1315
	High (Black)	1820	1770	1690	1600	1500
48	Low (Red)	1775	1710	1645	1565	1470
	Med (Blue)	1995	1895	1800	1685	1560
	High (Black)	2070	1970	1850	1719	1595
60	Low (Red)	1675	1630	1580	1520	1450
	Med (Blue)	1965	1925	1875	1800	1695
	High (Black)	2140	2085	2000	1895	1795

NOTE — Refer to wiring diagram located on the unit access panel and blower performance (table 1).

- All air data measured external to unit with 1 inch non-pleated air filter in place.
- All factory settings are medium speed except the -48 which is set to low speed from the factory.
- All data given while air handler is operating with a dry DX coil.
- Blower Performance (CFM vs. ESP inches H₂O)
- Cooling speeds should not be reduced below factory setting.
- Units with electric heat approved at 0.5" maximum and medium blower speed minimum.

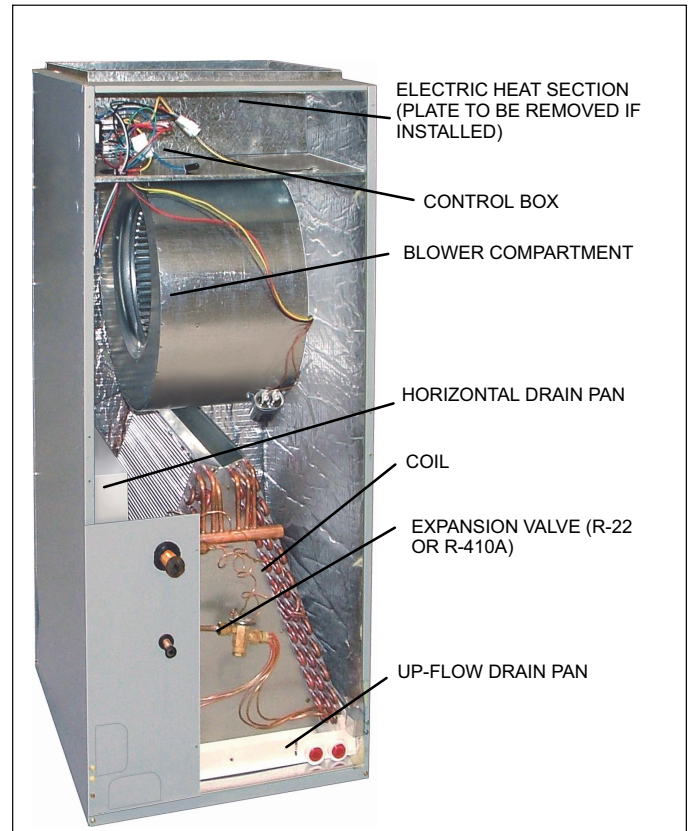

Figure 2. Unit Parts Arrangement

Application

All major blower coil components must be matched according to Lennox recommendations for the unit to be covered under warranty. Refer to the Product Specification bulletin for approved system matchups. A misapplied system will cause erratic operation and can result in early unit failure. The units come with factory installed check and expansion valve for all applications. The TXV valve has been installed internally for a cleaner installation and is accessible if required.

Unit Components

CONTROL BOX

The CBX25UH control box is located above the blower section shown in figure 2. Line voltage and electric heat connections are made in the control box. Optional electric heat fits through an opening located in the center of the control box. When electric heat is not used, cover plates cover the opening. The electric heat control arrangement is detailed in the electric heat section of this manual.

TRANSFORMER

All CBX25UH series units use a single line voltage to 24VAC transformer mounted in the control box. The transformer supplies power to the control circuits in the indoor and outdoor unit. Transformers are rated at 40VA. 208/240VAC single phase transformers use two primary voltage taps as shown in figure 3.

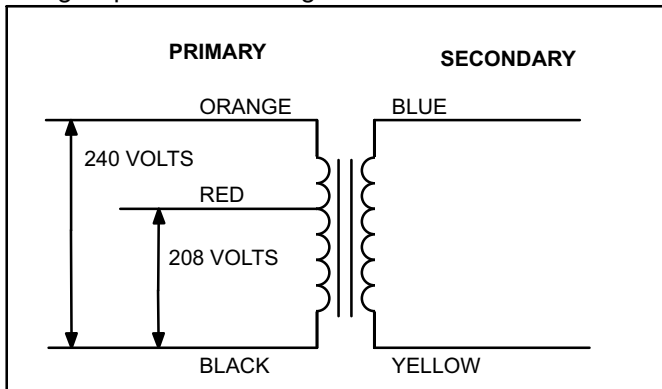

Figure 3. 208/240 Volt Transformer

BLOWER RELAY

All CBX25UH units use a double-pole single-throw (DPST) switch relay to energize the blower motor. The relay coil is energized by blower demand from indoor thermostat. When the coil is energized, a set of normally open (N.O.) contacts closes to energize the blower motor on cooling speed. When de-energized, a set of normally closed (N.C.) contacts allows the electric heat relay to energize the blower on heating speed (refer to unit wiring diagram).

TIME DELAY RELAY

Blower time delay operation:

1. When cooling demand is initiated, there is a 1 second motor-on delay.

2. After the motor-on delay expires, motor ramps up to 100% and runs at 100% until cooling demand is satisfied.
3. Once demand is met, motor runs at 100% for 45 seconds.
4. Motor ramps down to stop.

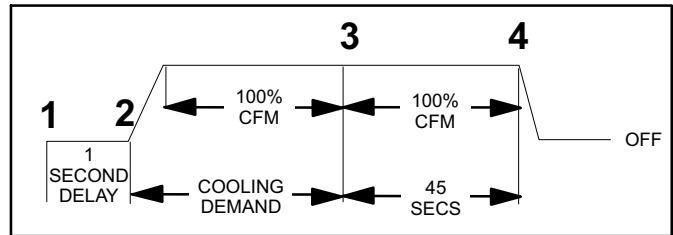

Figure 4. Blower Time Delay

BLOWER MOTOR (B3)

CBX25UH units use single-phase direct drive blower motors with a run capacitor. Figure 5 shows the parts arrangement. All motors have three speed taps. Typically, the high speed tap is energized during normal operation.

All units are factory wired for heat pump and cooling applications with or without electric heat. The unit wiring diagrams will provide factory set blower speeds.

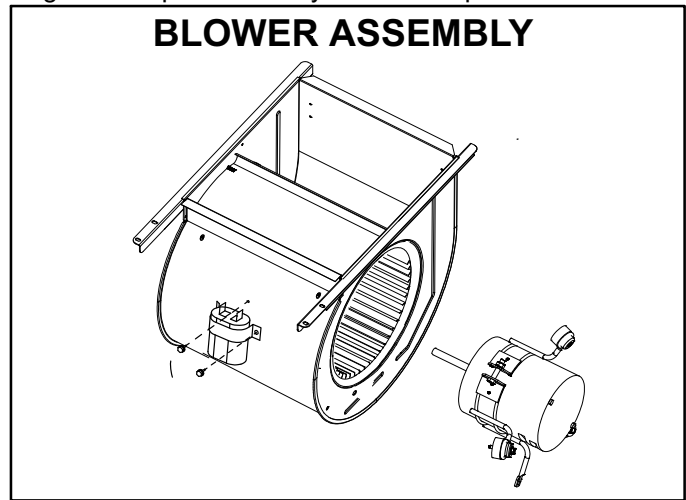

Figure 5. Blower Assembly

BLOWER MOTOR CAPACITOR

All CBX25UH series units use single-phase direct drive motors with a run capacitor. The run capacitor is mounted on the blower housing. See figure 5. Capacitor ratings are shown on side of capacitor and indoor blower motor nameplate.

COIL

CBX25UH units have dual slab coils arranged in an A configuration. Each coil has two or three rows of copper tubes fitted with ripple-edged aluminum fins. An expansion valve, feeds multiple parallel circuits through the coils. The coil is designed to easily slide out of the unit cabinet.

PLASTIC DRAIN PANS

Drain pans are provided and installed on the CBX25UH. The drain pans are made from fiberglass filled plastic.

Optional ECB25 Electric Heat

The electric heat sections provide field installed electric heat for air handler units.

Table 2 shows the available heat sections. Refer to the Product Specifications for heat section applications.

Table 2. Electric Heat Sections

Termination Type	Part Number	Catalog Number
2.5kW with stripped wires	0668142-10	89W42
5 kW with terminal block	0668142-02	89W43
5 kW with breaker	0668142-03	89W44
7.5 kW with breaker	0668142-04	89W45
7.5 kW with terminal block	0668142-05	89W46
10 kW with terminal block	0668142-06	89W47
10 kW with breaker	0668142-07	89W48
12.5 kW with breaker	0668142-11	89W49
15 kW with breaker	0668142-08	89W50
20 kW with breaker	0668142-09	89W51

HEAT SECTION INSTALLATION

Be sure to disconnect all power to the unit while you install and service this equipment. Use proper tools and protective equipment during installation and service.

Before installing the unit, check information on the unit rating plate to ensure that the unit meets the job specification, proper electrical power is available, and that proper duct clearances are maintained.

⚠ WARNING

Before installing or servicing unit, be sure ALL power to the unit is OFF. More than one disconnect switch may be present. *Electrical shock can cause personal injury or death!*

NOTE - If installing heat sections at the same time as the air handler unit, install the electric heat section in the air handler unit before setting the air handler unit and attaching the plenum.

1. Shut off all power to the air handler unit. More than one disconnect may be required.
2. Remove air handler access panel and keep the 6 screws to reattach access panel after installing heat elements.
3. Disconnect any existing field supply wires and pull them out of the air handler. Disconnect and remove wiring harness and fastener (see figure 6). If not removed, these items will prevent the heat section's base from resting properly in the compartment.
4. Remove the no-heat seal plate in the air handler frame. See figure 6.

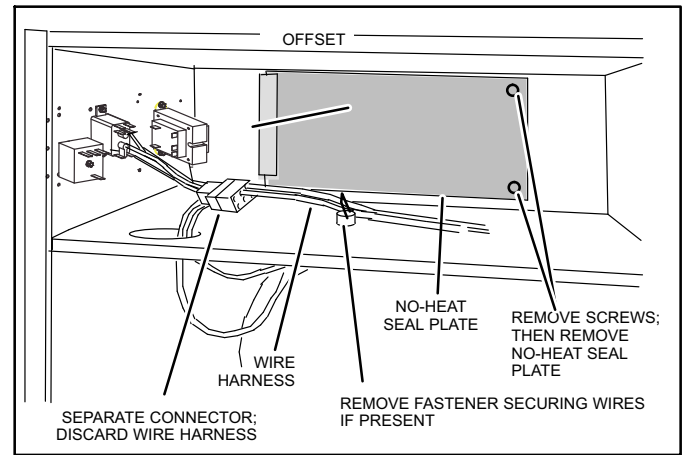

Figure 6. Prepare to Install Heat Element

5. Slide the electric heat section into the air handler. Be careful that the heating elements do not rub against the sheet metal opening when they slide into the air handler. The side opposite the side with the mounting holes should slip behind the offset. The mounting holes should then line up with holes in the air handler control box.
6. Secure the electric heater assembly into place with the screws that were removed from the heat element panel. Install two field-provided #8 SDST screws in the front of the electric heater assembly (see figure 7).

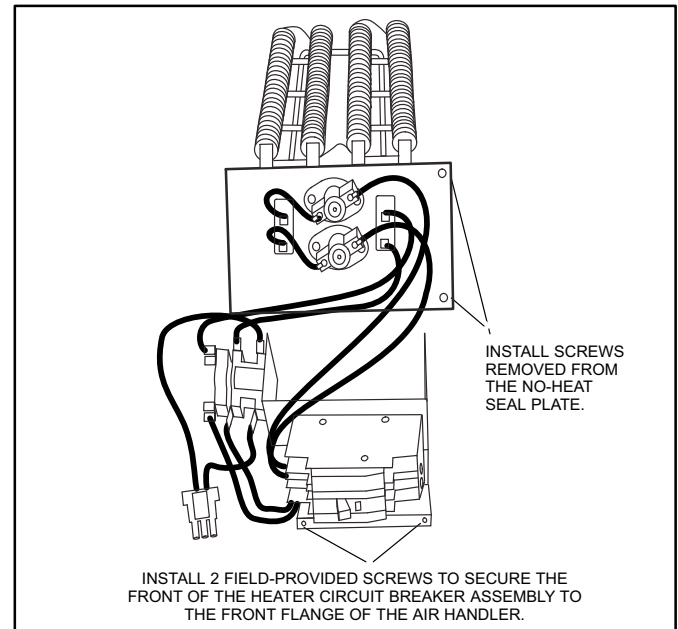

Figure 7. Installing the Heat Element Assembly

- The air handler access panels have knockouts over the circuit breaker opening. Knock out both plates to accommodate the circuit breaker levers. If installing a heat element assembly with circuit breakers, remove the knockouts but do not install the access panel until all electrical connections have been completed.

IMPORTANT - To remove knockouts, knock them out in the same direction the punch did. Always start with the smallest knockout and work outward to the knockout for the appropriately-sized hole.

⚠ WARNING

Foil face insulation must be cut to eliminate the possibility for any frayed foil to coming in contact with any main or low voltage connections. Insulation must be kept a minimum of 1/2" away from any electrical connection.

CHANGING CIRCUIT BREAKER ORIENTATION

The air handler comes from the factory setup for horizontal left-hand discharge which will require no change in the circuit breaker orientation. However, if the air handler is installed in a horizontal right-hand discharge position, the breaker will need to be rotated 180° so that the **UP** position of the breaker is the **ON** position. The circuit breaker orientation change is required by UL 1995, Article 26.18 (25 September 2005).

- The factory default configuration for the two circuit breakers is horizontal left-hand discharge which will

require no change (see figure 9). To change the applicable circuit breakers orientation for right-hand discharge, proceed to step 2.

- Locate the one clip which is located on the right side (see arrow) of each breaker (see figure 8). The clip secures the circuit breaker to the mounting bracket. Pull the clip to release the breaker from the mounting bracket.

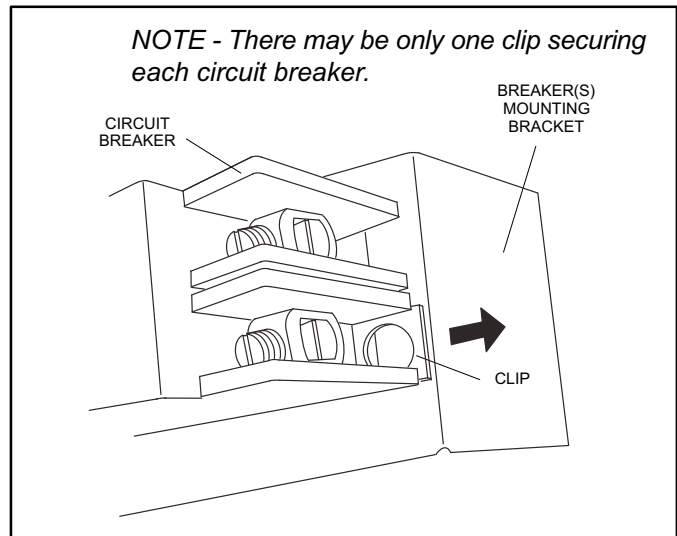

Figure 8. Circuit Breaker Clip

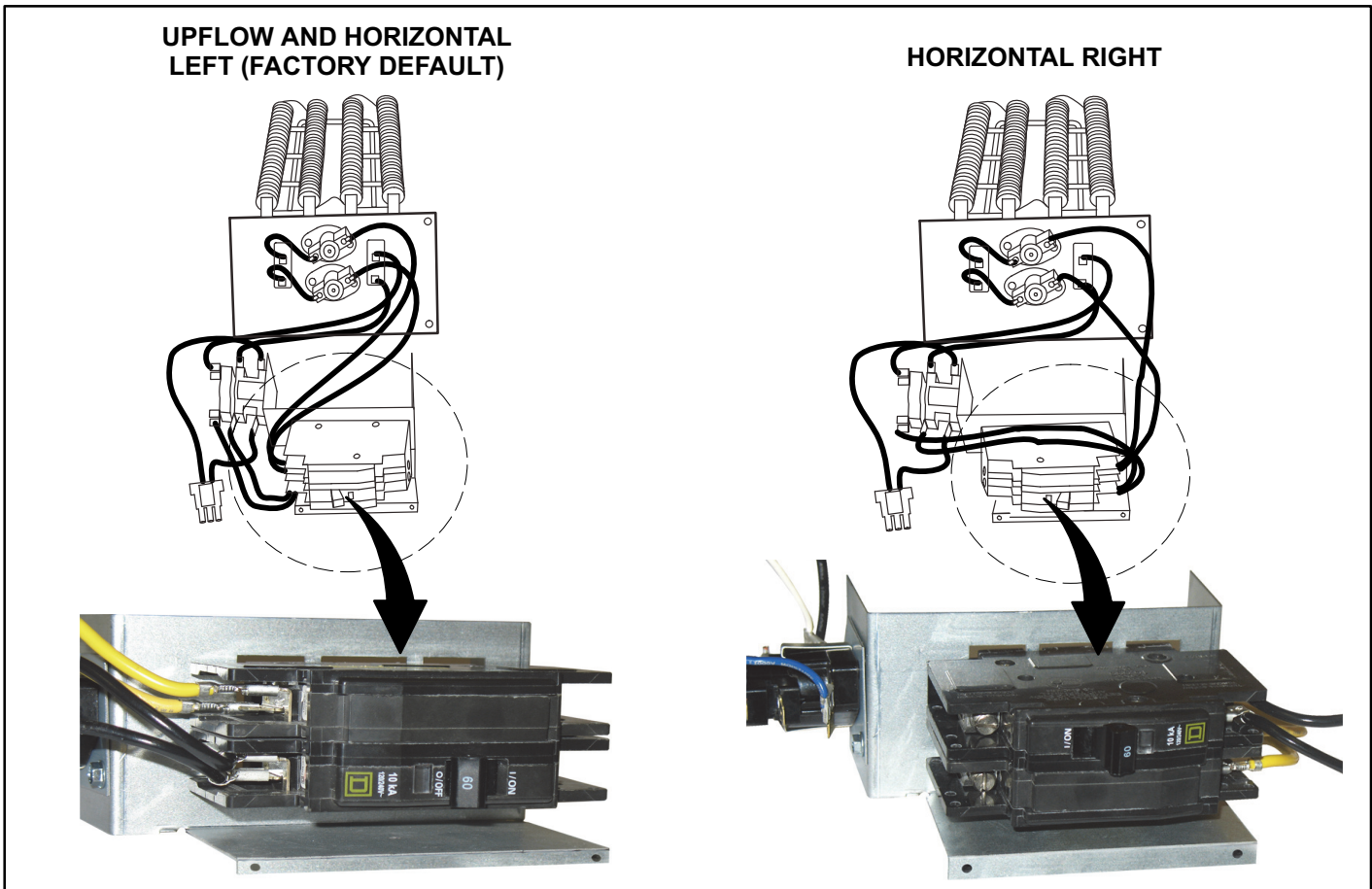

Figure 9. Circuit Breaker Orientation

3. Flip the breaker so that the wires attached to the circuit breaker terminals are on the left side (see figure 9).
4. Use the black clip to reattach the circuit breaker to the mounting bracket.

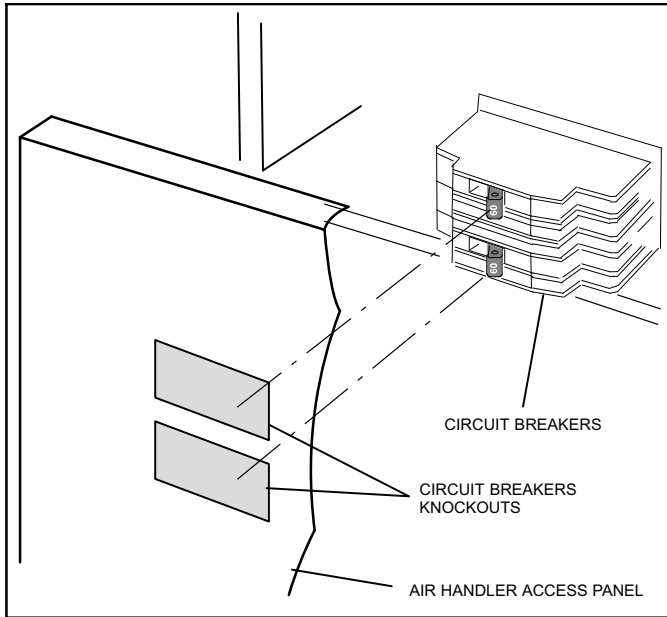

Figure 10. Circuit Breaker Knockouts

BREAKER ELECTRICAL CONNECTIONS

⚠ WARNING

Electric shock hazard! - Disconnect all power supplies before servicing.
 Replace all parts and panels before operating.
 Failure to do so can result in death or electrical shock.

⚠ WARNING

USE COPPER CONDUCTORS ONLY.

NOTE - Refer to the nameplate on the air handler unit for minimum circuit ampacity and maximum overcurrent protection size.

The air handler units are provided with openings to be used with 1-1/2 inch trade size (1-31/32 inch diameter) conduit.

If you want a single point power supply, refer to the nameplate on the single point power supply accessory for minimum circuit ampacity and maximum overcurrent protection size. Select the proper supply circuit conductors

in accordance with tables 310-16 and 310-17 in the National Electric Code, ANSI/NFPA No. 70 or tables 1 through 4 in the Canadian Electric Code, Part I, CSA Standard C22.1.

Refer to figure 28 for typical low voltage field wiring for air handler/condensing unit and heat pump applications. Figure 29 is a diagram of the air handler connections and the heater elements high-voltage wiring.

1. Make wiring connections as follows -

Heaters equipped with circuit breakers—Connect field power supply wiring to circuit breaker(s). Figure 11 shows L1, L2 and ground GND connections for a 2-breaker configuration.

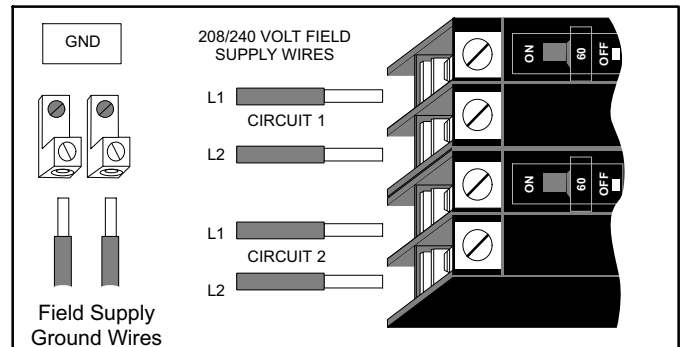

Figure 11. Field Power Supply Wiring

Heaters equipped with terminal blocks—Connect field power supply wiring to terminal block(s). Figure 12 shows L1, L2 and ground (GND) connection for a terminal block configuration.

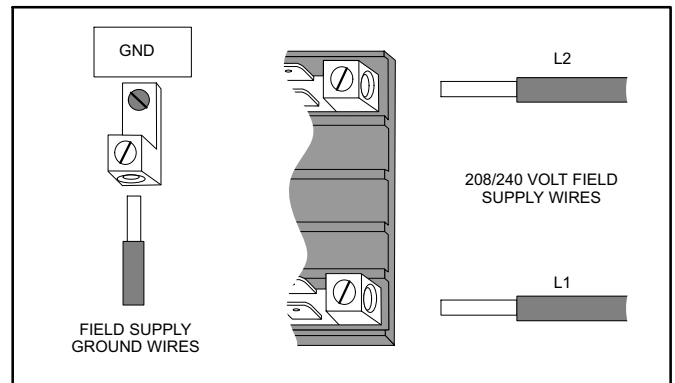

Figure 12. Terminal Block Connections

2. Remove the interface harness from the air handler unit and connect the 6-pin connector on the heater assembly to the mating connector on the air handler unit.
3. For applications using a two-stage room thermostat and/or an outdoor thermostat, connect wiring as shown in figure 28.

CIRCUIT BREAKER COVER INSTALLATION

1. Remove any installed patch plates still present .
2. Remove paper covering adhesive back around backside perimeter of circuit breaker cover (figure 13).
3. Position the breaker cover over the air handler circuit breaker opening (figure 14).

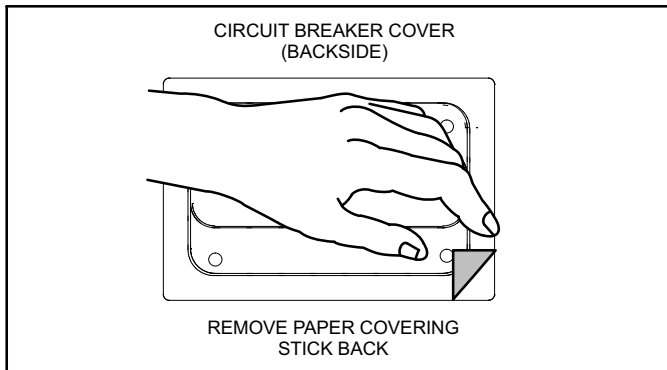

Figure 13. Remove Paper Cover

⚠ IMPORTANT

Confirm air tight seal between breaker cover and air handler access panel. Apply a thin silicone bead to the adhesive back seat to ensure air tight seal.

Failure to seal circuit breaker cover will allow warm moist air to be pulled into control panel which can create condensation to form on the circuit breaker and other electrical components within the control panel.

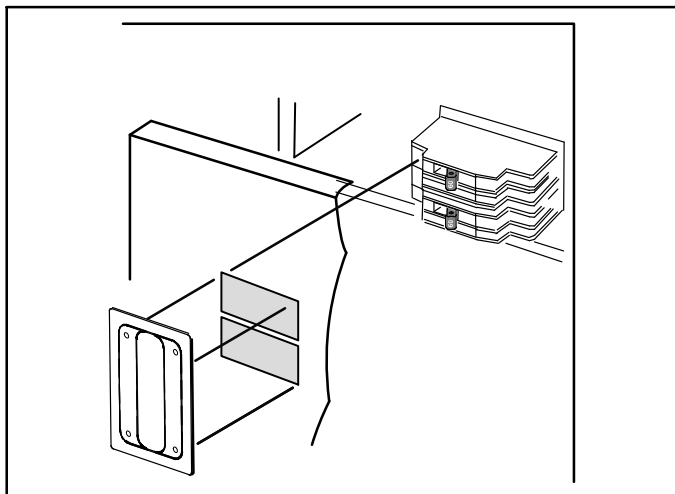

Figure 14. Typical Circuit Breaker Cover Installation

AIR HANDLER SPEED CONNECTIONS

When using the electric heat sections with air handler units, you must adjust the air handler speed according to the size of electric heat and air handler unit. **Air handler speed tap for electric heat in upflow and horizontal position is medium. For downflow it is high speed.** See specific air handler installation instructions for air handler speed adjustment procedure and location.

1. Set the thermostat above room temperature.
2. Check the heat pump and the heat section for normal operation.

3. Set the thermostat to desired setting.
4. Affix the wiring diagram sticker to air handler scroll, aligned with circuit breaker unit wiring diagram sticker.

Configuration Modification

UPFLOW APPLICATION

1. The air handler must be supported on the bottom only and set on solid floor or field-supplied support frame. Securely attach the air handler to the floor or support frame.
2. If installing a unit in an upflow application, remove the horizontal drain pan. **IMPORTANT - The horizontal drain pan is not required in upflow air discharge installations; its removal provides the best efficiency and air flow.**
3. Place the unit in the desired location and slope unit as previously mentioned. Connect return and supply air plenums as required using sheet metal screws.
4. Install units that have no return air plenum on a stand that is at least 14" from the floor. This will allow proper air return.

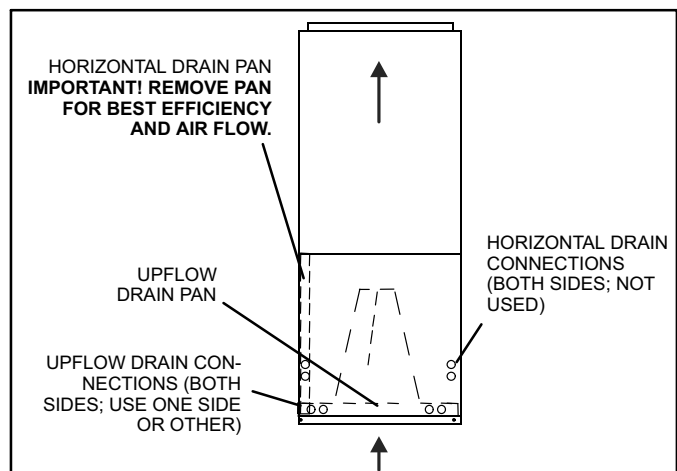

Figure 15. Upflow Configuration

HORIZONTAL APPLICATION

⚠ IMPORTANT

When removing the coil, there is possible danger of equipment damage and personal injury. Be careful when removing the coil assembly from a unit installed in right- or left-hand applications. The coil may tip into the drain pan once it is clear of the cabinet. Support the coil when removing it.

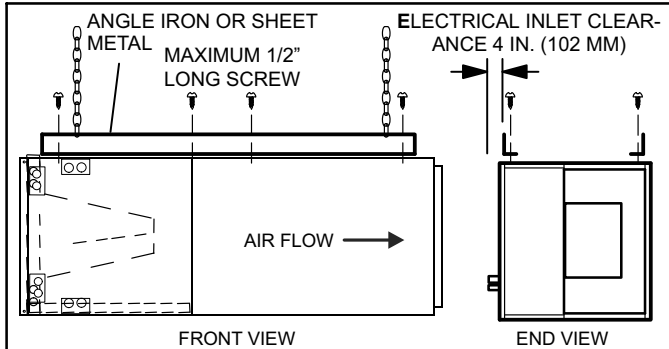

Figure 16. Suspending Horizontal Unit

NOTE — When the unit is installed in horizontal applications, a secondary drain pan is recommended. Refer to local codes.

NOTE — This unit may be installed in left-hand or right-hand air discharge horizontal applications. Adequate support must be provided to ensure cabinet integrity. Ensure that there is adequate room to remove service and access panels if installing in the horizontal position.

LEFT-HAND DISCHARGE

1. Determine which plugs are required for drain line connections.
2. With access door removed, remove drain line plugs to install drain lines.
3. Set unit so that it is sloped toward the drain pan end of the unit (see figure 25).
4. The horizontal configuration is shown in figure 17.

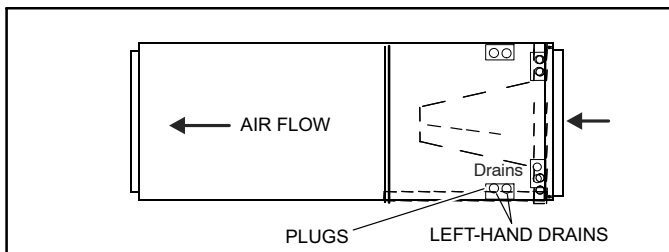

Figure 17. Left-Hand Discharge Configuration

5. If the unit is suspended, the entire length of the cabinet must be supported. If you use a chain or strap, use a piece of angle iron or sheet metal attached to the unit (either above or below) to support the length of the cabinet. Use securing screws no longer than 1/2 inch to avoid damaging the coil or filter. See figure 16. Use sheet metal screws to connect the return and supply air plenums as required.

RIGHT-HAND AIR DISCHARGE

For horizontal right-hand air discharge, the following field modifications are required.

1. Remove and set aside blower and coil access covers.
2. Remove brackets securing pan to unit. See figure 18.

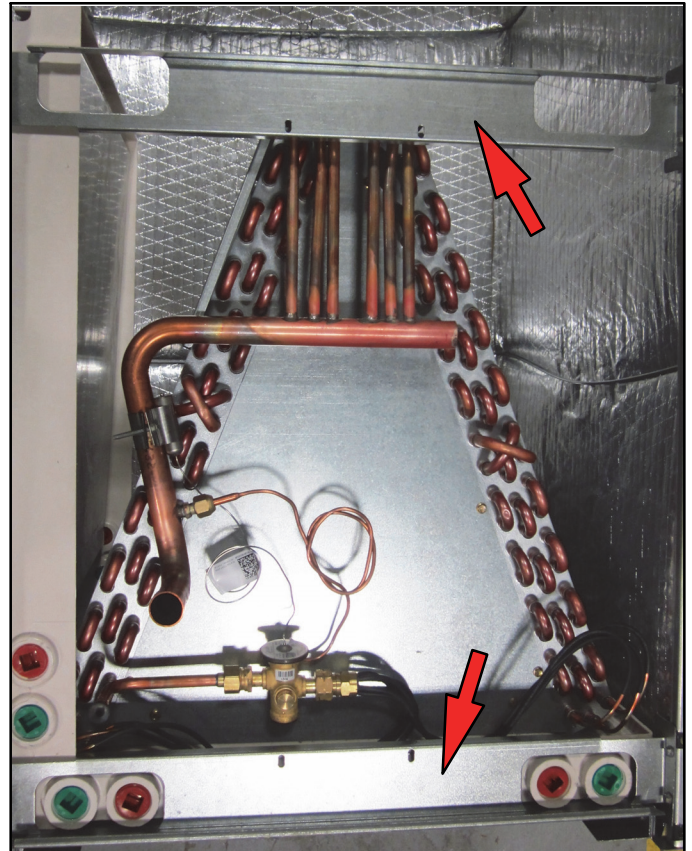

Figure 18. Remove Main Drain Pan Mounting Brackets

3. Remove coil assembly, bottom drain pan and horizontal drain pan as one unit from the air handler.

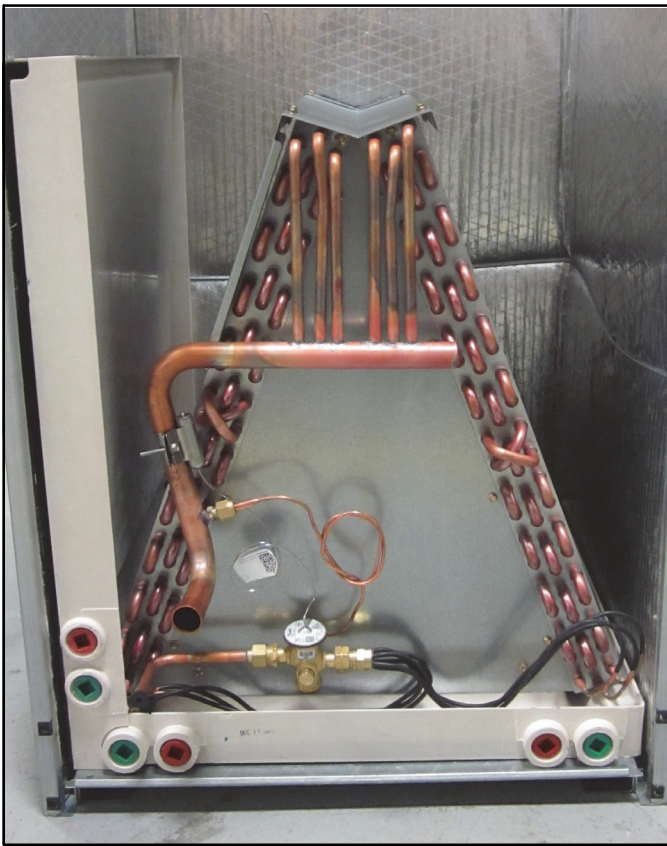

Figure 19. Remove Coil Assembly, Bottom Drain Pan and Horizontal Drain Pan as a Unit

4. Remove the blow-off prevention brackets, top cap and drip pan between slabs. Move the horizontal drain pan to the opposite side of the coil.

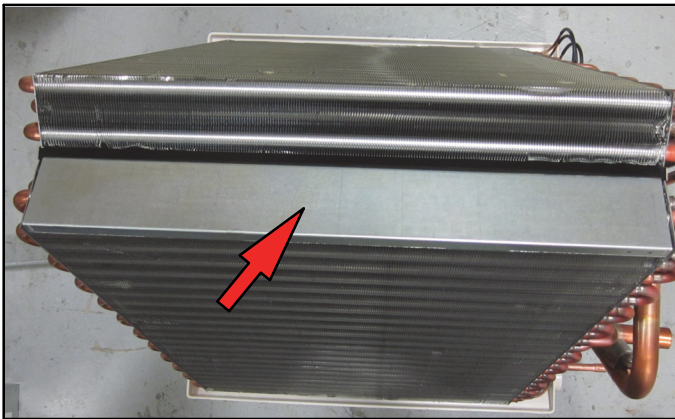

Figure 20. Remove Blow-Off Prevention Brackets, Top Cap and Drip Pan

5. Rotate drip pan 180° and reinstall on coil as shown by the arrow above. Reinstall the top cap. Rotate the blow-off prevention brackets 180° and reinstall using the same screws. Use the correct mounting holes; the brackets must cover the hairpins. See figure 21.

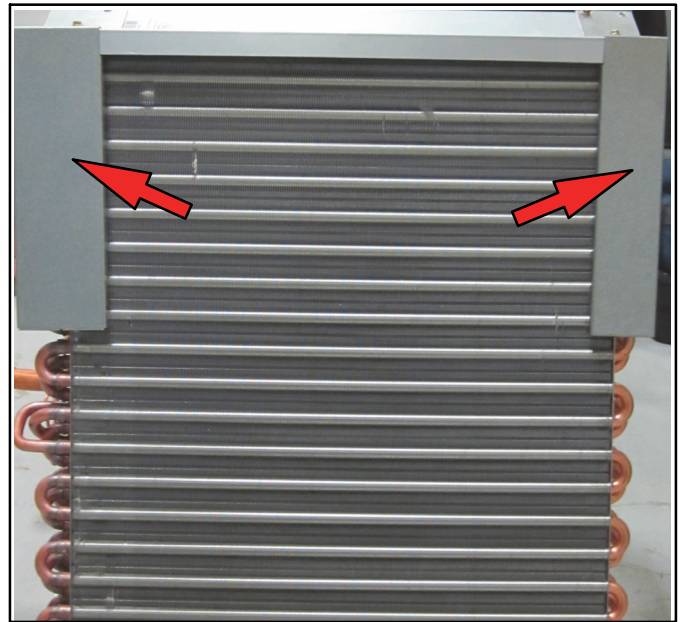

Figure 21. Reinstall the Top Cap. Brackets Must Cover the Hairpins

6. Slide coil assembly, bottom drain pan and horizontal drain pan as one unit back into the air handler.

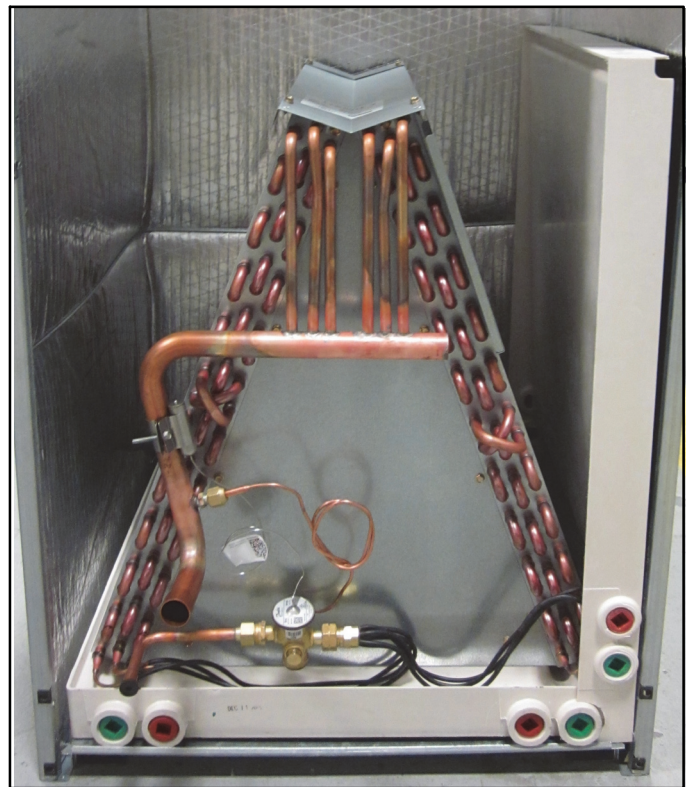

Figure 22. Slide Coil Assembly, Bottom Drain Pan and Horizontal Drain Pan Back Into the Air Handler as a Unit

7. Reinstall the brackets that hold the coil and horizontal drain pan in place. See figure 23.

8. Reinstall the blower and coil access panels.

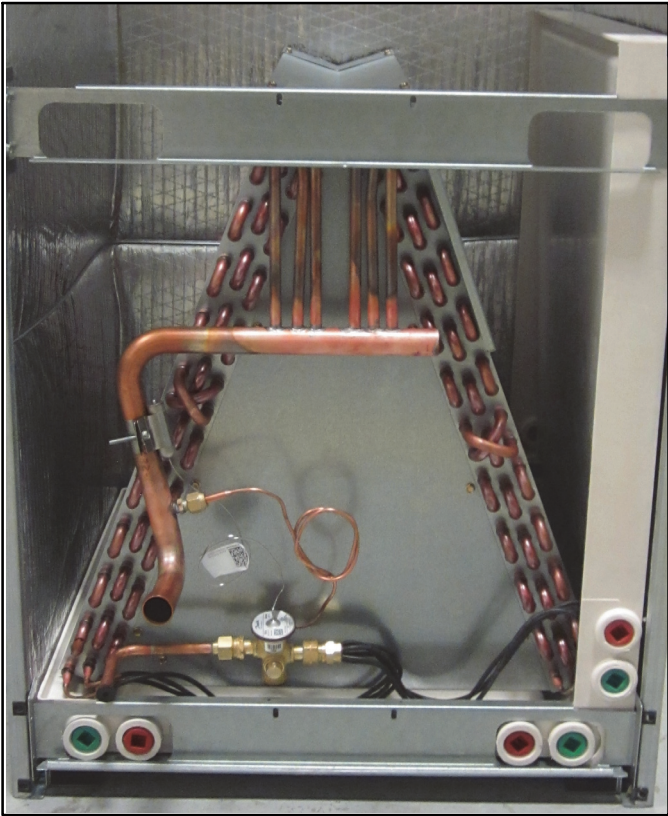

Figure 23. Reinstall Brackets that Hold the Coil and Horizontal Drain Pan in Place

⚠ IMPORTANT

On units of this type, where the blower “draws” rather than “blows” air through the coil, traps must be installed in the condensate drain lines (primary and auxiliary, if used). Traps prevent the blower from drawing air through the drain lines into the air supply.

CONDENSATE DRAIN

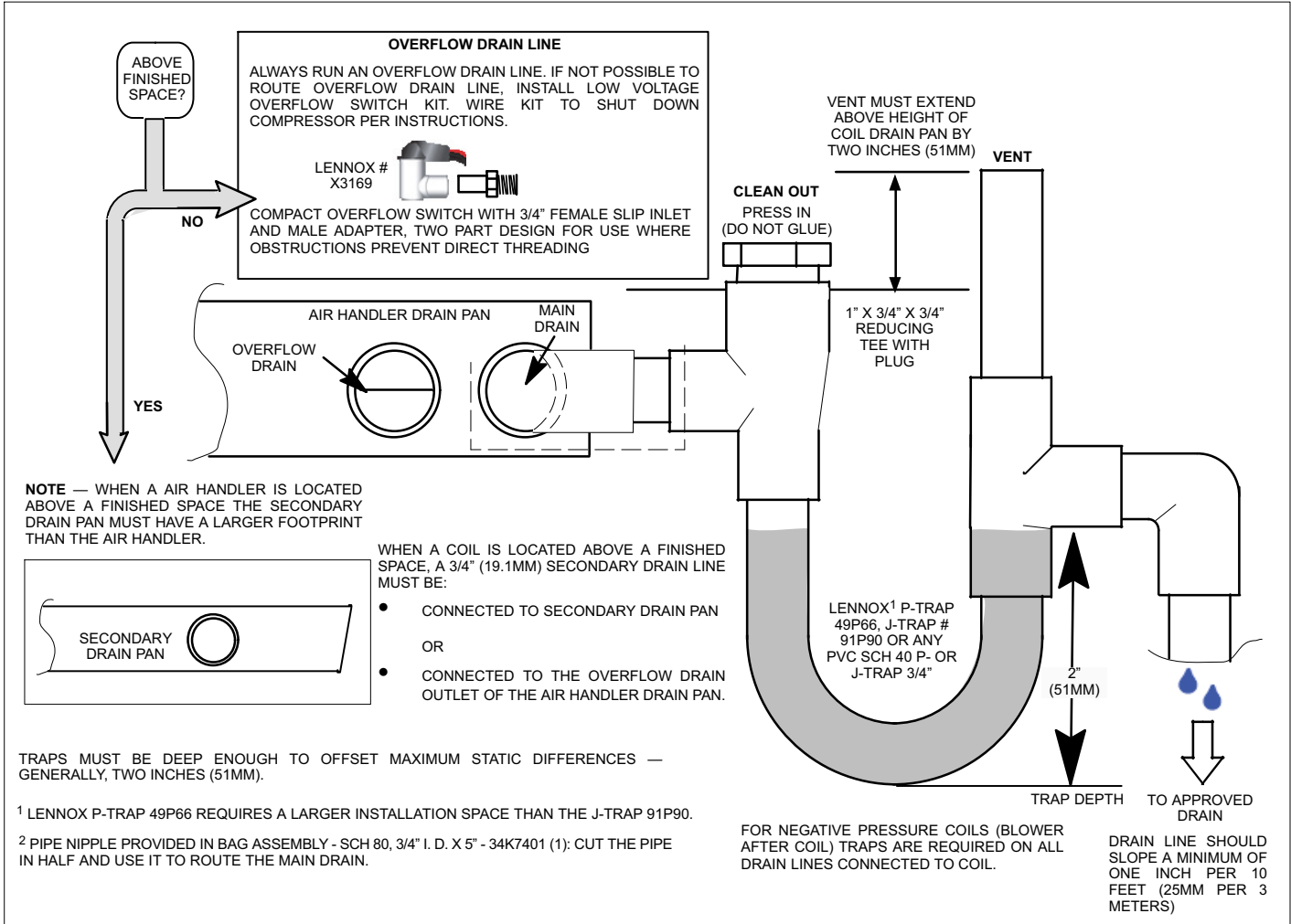

Figure 24. Typical Main and Overflow Drain



IMPORTANT

A field-fabricated secondary drain pan, with a drain pipe to the outside of the building, is required in all installations over a finished living space or in any area that may be damaged by overflow from the main drain pan. In some localities, local codes may require a secondary drain pan for any horizontal installation.

The air handler is provided with 3/4" NPT condensate drain connections.

SLOPING THE DRAIN

Make sure the unit is sloped (similar to the slope shown in figure 25) (horizontal or upflow) so that the drain pan will empty completely without water standing in the pan.

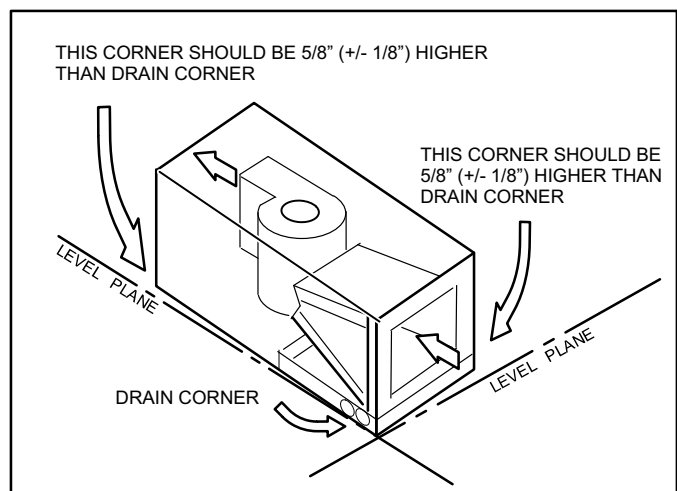

Figure 25. Sloping the Drain

INSTALL CONDENSATE DRAIN

1. Remove the appropriate drain knockouts. If necessary, remove the indoor coil assembly from the cabinet.
2. Connect primary drain line connection to the primary drain pan connection. The primary drain connection is flush with the bottom of the inside of the pan. Secondary connection is raised above the bottom of the inside of the pan.

NOTE — When making drain fitting connections to the drain pan, hand tighten the fitting and use a thread sealant. Over-tightening the fittings can split connections on the drain pan.

3. If the auxiliary drain line is to be used, remove the plug and route the drain line so that water draining from the outlet will be easily noticed by the homeowner. The auxiliary drain line does not require venting or a trap. Refer to local codes.
4. After removal of drain pan plugs, check the drain port to see if holes have been drilled. If not drilled, use a 19/32" bit to drill out the primary drain hole; use a 3/8" drill bit for the secondary drain hole. Remove all drill shavings.
5. Make sure drain ports and drain pan are free of all debris.
6. Plug and check any unused drain pan openings for tightness. Torque plugs to 30 in. lb. to prevent water leaks or seepage from the drain pan.
7. Install a 2" trap in the primary drain lines as close to the unit as practical (see figure 24). Make sure the top of the trap is below the connection to the drain pan to allow complete drainage of the pan.

NOTE — Horizontal runs must have an anti-siphon air vent (standpipe) installed ahead of the horizontal run (See figure 24). An extremely long horizontal run may require an oversized drain line to eliminate air trapping.

NOTE — Do not operate air handler without a drain trap. The condensate drain is on the negative pressure side of the blower; therefore, air being pulled through the condensate line will prevent positive drainage without a proper trap.

8. Route the drain line to the outside or to an appropriate drain. Drain lines must be installed so they do not block service access to the front of the air handler. A 24" clearance is required for filter, coil, or blower removal and service access.

NOTE — Check local codes before connecting the drain line to an existing drainage system.

Insulate the drain lines where sweating could cause water damage.

TEST CONDENSATE DRAIN

Test the drain pan and drain line after installation:

1. Pour several quarts of water into drain pan, enough to fill drain trap and line.
2. Check to make sure the drain pan is draining completely, no leaks are found in drain line fittings, and water is draining from the end of the primary drain line.
3. Correct any leaks found.

DUCT SYSTEM

The air handler is provided with flanges for the connection of the plenum and ducts. The air handler is equipped with flanges that can form a filter rack for the installation of the air filter, or the filter may be installed as part of the return air duct system.

Supply and return duct system must be adequately sized to meet the system's air requirements and static pressure capabilities. The duct system should be insulated with a minimum of 1" thick insulation with a vapor barrier in conditioned areas or 2" minimum in unconditioned areas.

Supply plenum should be the same size as the flanged opening provided around the blower outlet and should extend at least 3 ft. from the air handler before turning or branching off plenum into duct runs. The plenum forms an extension of the blower housing and minimizes air expansion losses from the blower.

INSTALLING DUCT SYSTEM

Connect supply air duct to the flange on top of the air handler. If an isolation connector is used, it must be nonflammable.

A return air duct system is recommended. If the unit is installed in a confined space or closet, a return connection must be run, full size, to a location outside the closet.

CONNECTING REFRIGERANT LINES

Refrigerant lines must be connected by a qualified technician in accordance with established procedures.



IMPORTANT

Refrigerant lines must be clean, dehydrated, refrigerant-grade copper lines. Air handler coils should be installed only with specified line sizes for approved system combinations.

Handle the refrigerant lines gently during the installation process. Sharp bends or possible kinking in the lines will cause a restriction.

Do not remove the caps from the lines or system connection points until connections are ready to be completed.

1. Route the suction and liquid lines from the fittings on the indoor coil to the fittings on the outdoor unit. Run the lines in as direct a path as possible avoiding unnecessary turns and bends.
2. Make sure that the suction line is insulated over the entire exposed length and that neither suction nor liquid lines are in direct contact with floors, walls, duct system, floor joists, or other piping.
3. Connect the suction and liquid lines to the evaporator coil.
4. To avoid damaging the rubber grommets in the cabinet while brazing, slide the rubber grommets over the refrigerant lines until they are away from the heat source.
5. Braze using an alloy of silver or copper and phosphorus with a melting point above 1,100°F (593°C).

NOTE — Do not use soft solder.

6. Reinstall the rubber grommets after brazing is finished.

7. Make sure outdoor unit has been put in place according to the Installation Instructions and is connected to the refrigerant lines.

SEALING THE UNIT

Seal the unit so that warm air is not allowed into the cabinet. Warm air introduces moisture, which results in water blow-off problems. This is especially important when the unit is installed in an unconditioned area.

If installed in an unconditioned space, sealant should be applied around the electrical wires, refrigerant tubing, and condensate lines where they enter the cabinet.

WARNING

There must be an airtight seal between the bottom of the air handler and the return air plenum. Use fiberglass sealing strips, caulking, or equivalent sealing method between the plenum and the air handler cabinet to ensure a tight seal. Return air must not be drawn from a room where this air handler or any gas-fueled appliance (i.e., water heater), or carbon monoxide-producing device (i.e., wood fireplace) is installed.

IMPORTANT

When sealing the cabinet, be sure to seal closed any space around the holes where the drain lines exit the cabinet using duct tape and/or Permagum. Warm air must not be allowed to enter through any gaps or holes in the cabinet.

Make sure the liquid line and suction line entry points are sealed with either ARMAFLEX material or with Permagum. Permagum may also be used to seal around the main and auxiliary drains and around open areas of electrical inlets.

Electrical Connections

WARNING



Electric shock hazard! - Disconnect all power supplies before servicing.
Replace all parts and panels before operating.
Failure to do so can result in death or electrical shock.

WARNING

Electric Shock Hazard.

Can cause injury or death.

Foil-faced insulation has conductive characteristics similar to metal. Be sure there are no electrical connections within a 1/2" of the insulation. If the foil-faced insulation comes in contact with electrical voltage, the foil could provide a path for current to pass through to the outer metal cabinet. While the current produced may not be enough to trip existing electrical safety devices (e.g. fuses or circuit breakers), the current can be enough to cause an electric shock hazard that could cause personal injury or death.

- All field wiring must be done in accordance with National Electrical Code, applicable requirements of UL and local codes, where applicable.
- Electrical wiring, disconnect means and over-current protection are to be supplied by the installer. Refer to the air handler rating plate for maximum over-current protection, minimum circuit ampacity, as well as operating voltage.
- The power supply must be sized and protected according to the specifications supplied on the product.
- This air handler is factory-configured for 240 volt, single phase, 60 cycles. For 208-volt applications, see "208 Volt Conversion" later in this section.
- For optional field-installed electric heat applications, refer to the instructions provided with the accessory for proper installation.

WARNING

USE COPPER CONDUCTORS ONLY

1. Disconnect all power supplies.
2. Remove the air handler access panel.
3. Route the field supply wires to the air handler electrical connection box.
4. Use UL-listed wire nuts to connect the field supply conductors to the unit black and yellow leads, and the ground wire to ground terminal marked **GND**.
5. Replace the air handler access panel.

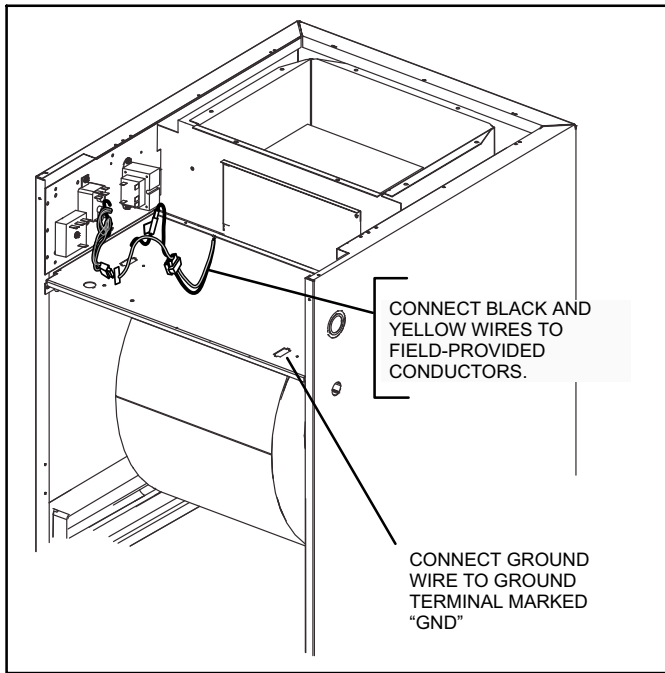

Figure 26. Making Electrical Connections

208 VOLT CONVERSION

1. Disconnect all power supplies.
2. Remove the air handler access panel.
3. Using the wiring diagram located on the unit access panel as a reference, move the 2 connected black transformer leads from the 240 volt terminal on the transformer to the 208 volt terminal on the transformer.

⚠ WARNING



Electrically ground air handler. Connect ground wire to ground terminal marked "GND".

Failure to do so can result in death or electrical shock.

Wiring Diagrams

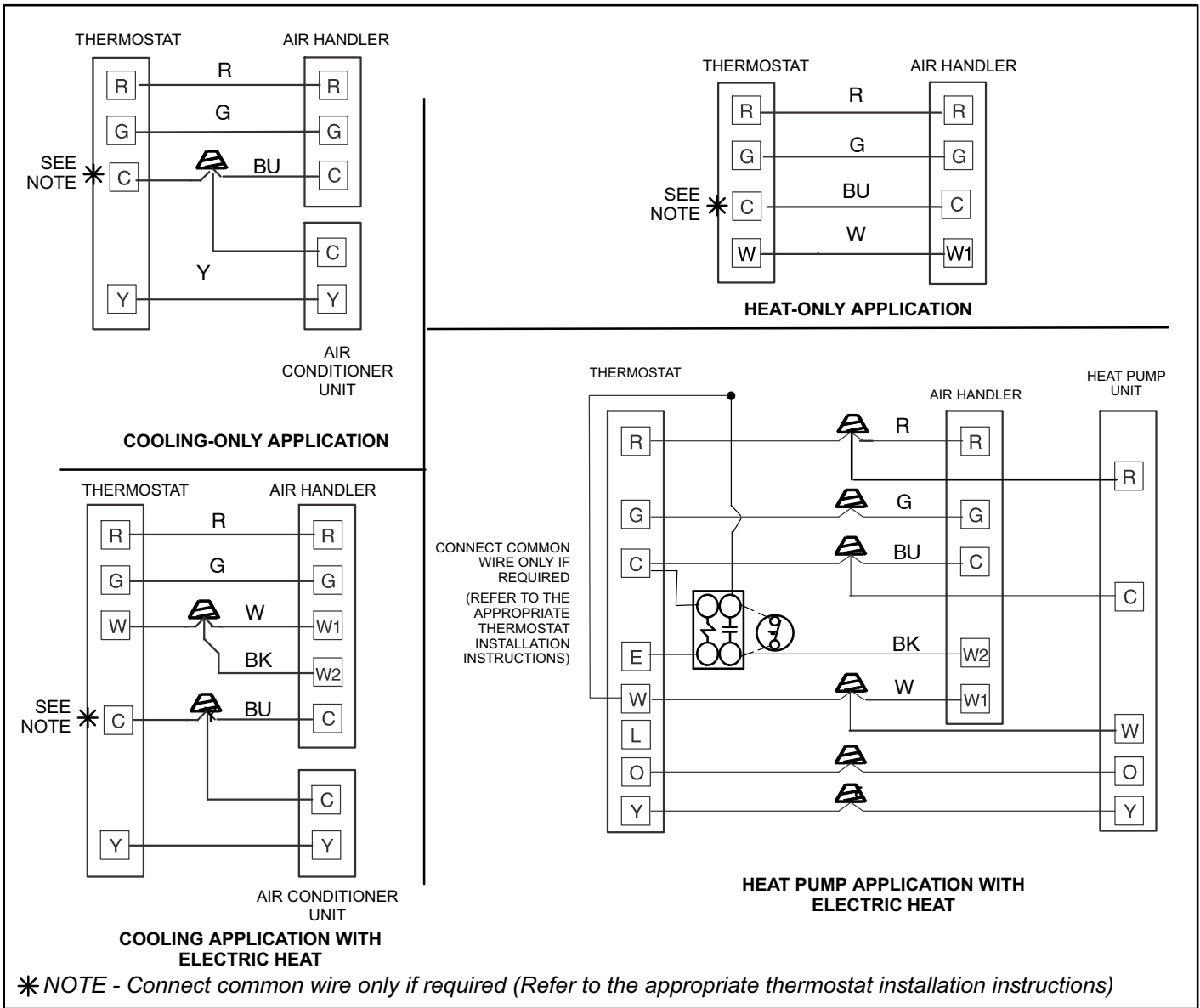

Figure 27. Low Voltage Connections (3-Speed PSC Motor) - Field Wiring

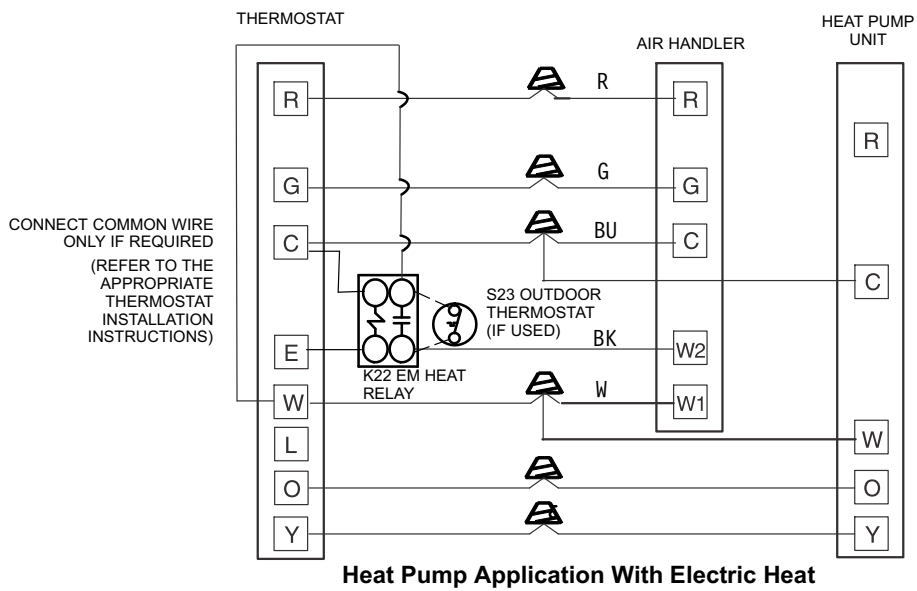
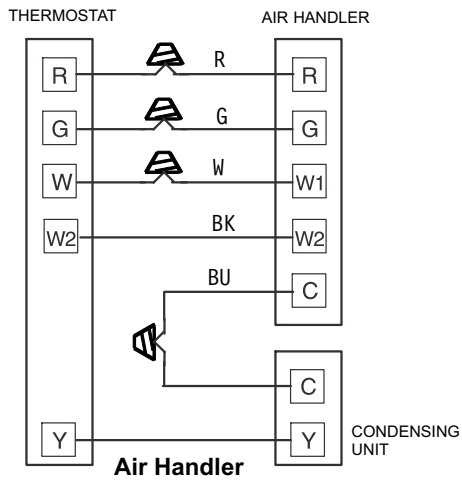

Figure 28. Low Voltage Field Wiring Electric Heat

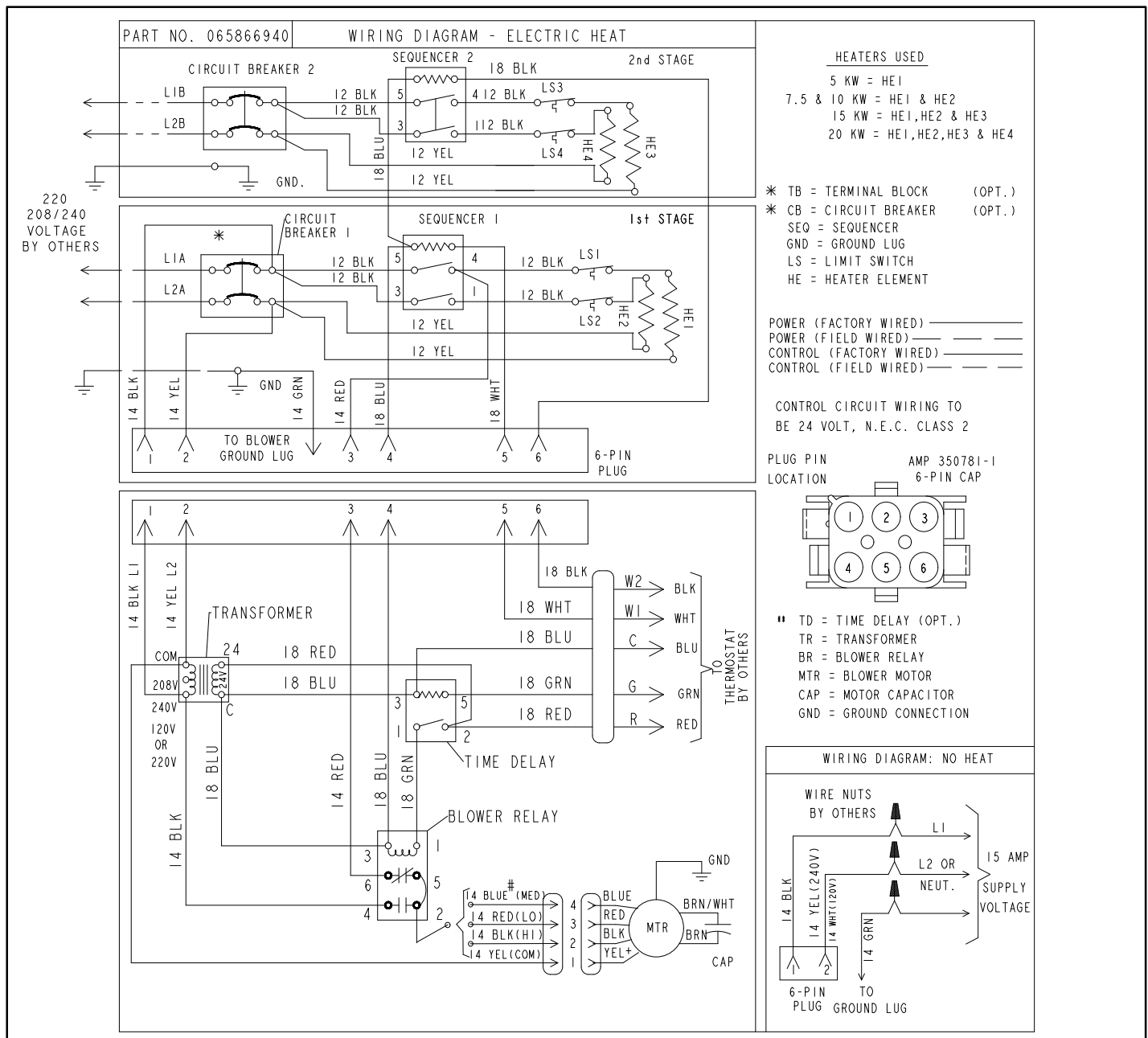

Figure 29. Unit Wiring Diagram - Electric Heat and Air Handler

Start-Up Operation

NOTE - Refer to outdoor unit installation instructions for system start-up instructions and refrigerant charging instructions.

PRE-START-UP CHECKS

- Is the air handler properly and securely installed?
- If horizontally configured, is the unit sloped up to 5/8 inch toward drain lines?
- Will the unit be accessible for servicing?
- Has an auxiliary pan been provided under the unit with separate drain for units installed above a finished ceiling or in any installation where condensate overflow could cause damage?
- Have ALL unused drain pan ports been properly plugged?

- Has the condensate line been properly sized, run, trapped, pitched, and tested?
- Is the duct system correctly sized, run, sealed, and insulated?
- Have all cabinet openings and wiring been sealed?
- Is the indoor coil factory-installed TXV properly sized for the outdoor unit being used?
- Have all unused parts and packaging been disposed of?
- Is the filter clean, in place, and of adequate size?
- Is the wiring neat, correct, and in accordance with the wiring diagram?
- Is the unit properly grounded and protected (fused)?
- Is the thermostat correctly wired and in a good location?

- Are all access panels in place and secure?

CHECK BLOWER OPERATION

- Set thermostat to FAN ON.
- The indoor blower should come on.

CHECK COOLING OPERATION

- Set thermostat to force a call for cooling (approximately 5°F lower than the indoor ambient temperature).
- The outdoor and indoor units should come on immediately.
- Check the airflow from a register to confirm that the system is moving cooled air.
- Set the thermostat 5°F higher than the indoor temperature. The indoor blower and outdoor unit should cycle off. Air handler should cycle off 45 seconds after the outdoor unit shuts off.

CHECK ELECTRIC HEATER (IF USED)

- Set thermostat to call for auxiliary heat (approximately 5°F above ambient temperature). The indoor blower and auxiliary heat should come on together. Allow a minimum of 3 minutes for all sequencers to cycle on.
- Set the thermostat so that it does not call for heat. Allow up to 5 minutes for all sequencers to cycle off.

Sequence of Operation

COOLING (COOLING ONLY OR HEAT PUMP)

When the thermostat calls for cooling, 24 volts is put on the blower time-delay relay coil and then the indoor blower relay energizes. The normally open contacts close, causing the indoor blower motor to operate. The circuit between **R** and **Y** is completed, closing the circuit to the contactor in the outdoor unit, starting the compressor and outdoor fan motor.

On heat pumps, circuit **R** and **O** energizes the reversing valve, switching the valve to the cooling position. (The reversing valve remains energized as long as the thermostat selector switch is in the **COOL** position.)

At the completion of the cooling demand the indoor blower and outdoor unit should cycle off. Air handler should cycle off 45 seconds after the outdoor unit shuts off.

HEATING (ELECTRIC HEAT ONLY)

When the thermostat calls for heat, the circuit between **R** and **W** is completed, and the heat sequencer is energized. A time delay follows before the heating elements and the indoor blower motor come on. Units with a second heat sequencer can be connected with the first sequencer to **W** on the thermostat subbase, or they may also be connected to a second stage on the subbase.

HEATING (HEAT PUMP)

When the thermostat calls for heating, 24 volts is put on the blower time-delay relay coil. Then normally open contacts close, causing the indoor blower motor to operate. The circuit between **R** and **Y** is completed, closing the circuit to the contactor in the outdoor unit, starting the compressor and outdoor fan motor.

If the room temperature should continue to fall, the circuit between **R** and **W1** is completed by the second-stage heat room thermostat. Circuit **R-W1** energizes a heat sequencer. The completed circuit will energize supplemental electric heat (if applicable). Units with a second heat sequencer can be connected with the first sequencer to **W1** on the thermostat. They may also be connected to a second heating stage **W2** on the thermostat subbase.

EMERGENCY HEAT (HEATING HEAT PUMP)

If the selector switch on the thermostat is set to the emergency heat position, the heat pump will be locked out of the heating circuit, and all heating will be electric heat (if applicable). A jumper should be placed between **W2** and **E** on the thermostat subbase so that the electric heat control will transfer to the first-stage heat on the thermostat. This will allow the indoor blower to cycle on and off with the electric heat when the fan switch is in the **AUTO** position.

Performance Checklists

Installing Contractor's Name _____ Installing Date _____
 Installing Contractor's Phone _____ Air Handler Model # _____
 Job Address _____

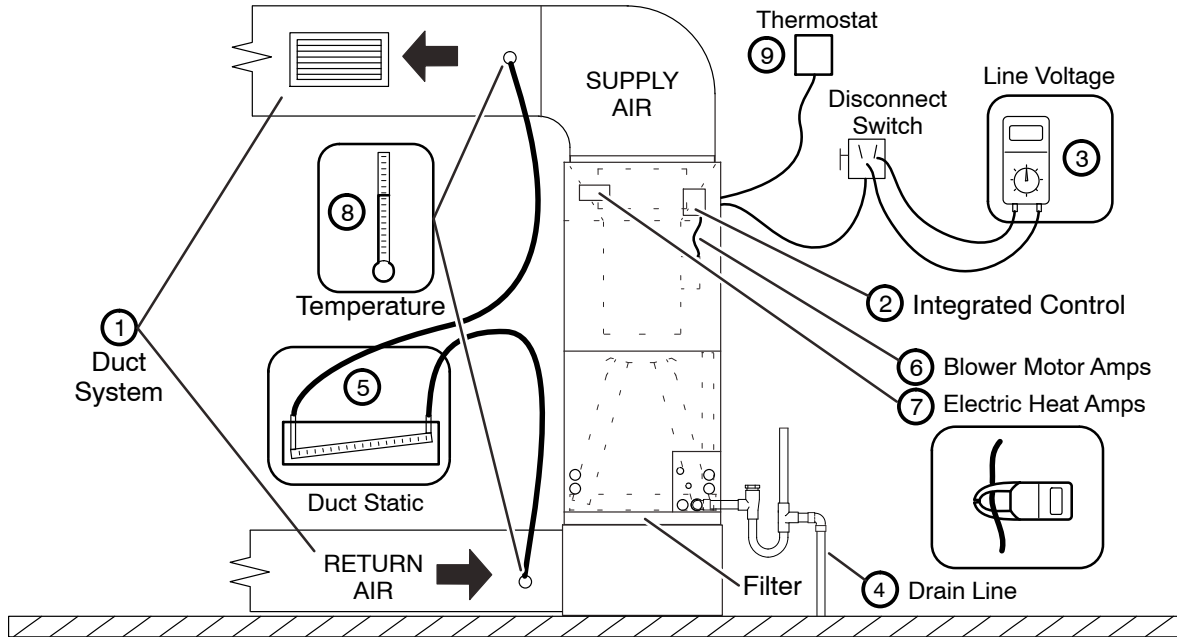

- | | |
|-------------------------------------------------------------------------------------------------------------------------------------------------------------------------------------------------------------------------------------------------------------------------------------------------------------------------------------------------------------------------------------------------------------------------------------------------------------------------------------------------------------------------------------------------------------------------------------------------------------------------------------------------------------------------------------------------------------------------------------------------------------------------------------------------------------------------------------------------------------------------------------------------------------------------------------------------------------|---------------------------------------------------------------------------------------------------------------------------------------------------------------------------------------------------------------------------------------------------------------------------------------------------------------------------------------------------------------------------------------------------------------------------------------------------------------------------------------------------------------------------------------------------------------------------------------------------------------------------------------------------------------------------------------------------------------------------------------------------------------------------------------------------------------|
| <p>① DUCT SYSTEM</p> <p>SUPPLY AIR DUCT</p> <p><input type="checkbox"/> Sealed</p> <p><input type="checkbox"/> Insulated (if necessary)</p> <p><input type="checkbox"/> Registers Open and Unobstructed</p> <p>RETURN AIR DUCT</p> <p><input type="checkbox"/> Sealed</p> <p><input type="checkbox"/> Filter Installed and Clean</p> <p><input type="checkbox"/> Registers Open and Unobstructed</p> <p>② INTEGRATED CONTROL</p> <p><input type="checkbox"/> Jumpers Configured Correctly (if applicable)</p> <p><input type="checkbox"/> Appropriate Links in Place (if applicable)</p> <p>③ VOLTAGE CHECK</p> <p><input type="checkbox"/> Supply Voltage _____</p> <p><input type="checkbox"/> Low Voltage _____</p> <p><input type="checkbox"/> Electrical Connections Tight</p> <p>④ DRAIN LINE</p> <p><input type="checkbox"/> Leak Free</p>
<p><input type="checkbox"/> Explained Operation of System to Homeowner</p> | <p>⑤ TOTAL EXTERNAL STATIC (dry coil)</p> <p style="text-align: right;">dry coil wet coil</p> <p>Supply External Static _____</p> <p>Return External Static _____</p> <p>Total External Static = _____</p> <p>⑥ ELECTRIC HEAT AMPS _____</p> <p>⑦ INDOOR BLOWER AMPS _____</p> <p>INDOOR BLOWER CFM _____</p> <p>⑧ TEMPERATURE DROP (Cooling Mode)</p> <p>Return Duct Temperature _____</p> <p>Supply Duct Temperature - _____</p> <p>Temperature Drop = _____</p> <p>⑧ TEMPERATURE RISE (Heating Mode)</p> <p>Return Duct Temperature _____</p> <p>Supply Duct Temperature - _____</p> <p>Temperature Rise = _____</p> <p>⑨ THERMOSTAT</p> <p><input type="checkbox"/> Adjusted and Programmed</p> <p><input type="checkbox"/> Operation Explained to Owner</p> |
|-------------------------------------------------------------------------------------------------------------------------------------------------------------------------------------------------------------------------------------------------------------------------------------------------------------------------------------------------------------------------------------------------------------------------------------------------------------------------------------------------------------------------------------------------------------------------------------------------------------------------------------------------------------------------------------------------------------------------------------------------------------------------------------------------------------------------------------------------------------------------------------------------------------------------------------------------------------|---------------------------------------------------------------------------------------------------------------------------------------------------------------------------------------------------------------------------------------------------------------------------------------------------------------------------------------------------------------------------------------------------------------------------------------------------------------------------------------------------------------------------------------------------------------------------------------------------------------------------------------------------------------------------------------------------------------------------------------------------------------------------------------------------------------|

Technician's Name: _____ Date Start-Up & Performance Check Completed _____

Figure 30. Start-Up and Performance Checklist (Upflow Configuration)

Installing Contractor's Name _____ Installing Date _____
 Installing Contractor's Phone _____ Air Handler Model # _____
 Job Address _____

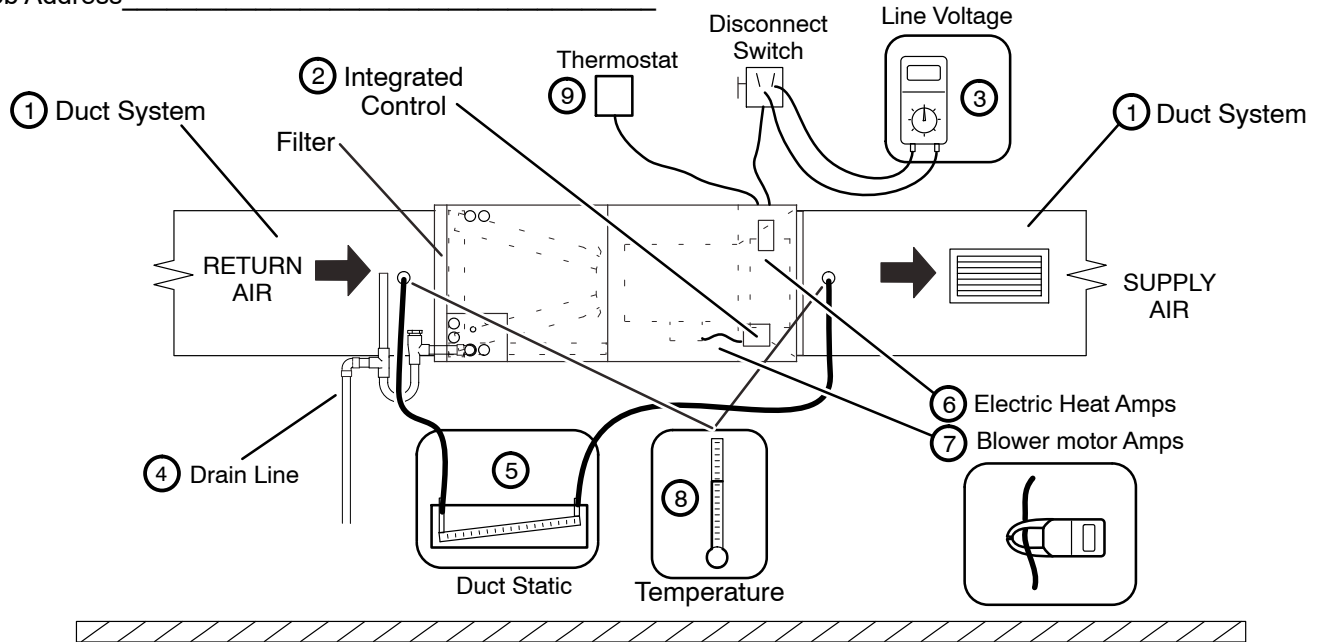

- | | |
|-------------------------------------------------------------------------------------------------------------------------------------------------------------------------------------------------------------------------------------------------------------------------------------------------------------------------------------------------------------------------------------------------------------------------------------------------------------------------------------------------------------------------------------------------------------------------------------------------------------------------------------------------------------------------------------------------------------------------------------------------------------------------------------------------------------------------------------------------------------------------------|---------------------------------------------------------------------------------------------------------------------------------------------------------------------------------------------------------------------------------------------------------------------------------------------------------------------------------------------------------------------------------------------------------------------------------------------------------------------------------------------------------------------------------------------------------------------------------------------------------------------------------------------------------------------------------------------------------------------------------------------------------------------------------------------------------------|
| <p>① DUCT SYSTEM</p> <p>SUPPLY AIR DUCT</p> <p><input type="checkbox"/> Sealed</p> <p><input type="checkbox"/> Insulated (if necessary)</p> <p><input type="checkbox"/> Registers Open and Unobstructed</p> <p>RETURN AIR DUCT</p> <p><input type="checkbox"/> Sealed</p> <p><input type="checkbox"/> Filter Installed and Clean</p> <p><input type="checkbox"/> Registers Open and Unobstructed</p> <p>② INTEGRATED CONTROL</p> <p><input type="checkbox"/> Jumpers Configured Correctly (if applicable)</p> <p><input type="checkbox"/> Appropriate Links in Place (if applicable)</p> <p>③ VOLTAGE CHECK</p> <p><input type="checkbox"/> Supply Voltage _____</p> <p><input type="checkbox"/> Low Voltage _____</p> <p><input type="checkbox"/> Electrical Connections Tight</p> <p>④ DRAIN LINE</p> <p><input type="checkbox"/> Leak Free</p> | <p>⑤ TOTAL EXTERNAL STATIC (dry coil)</p> <p style="text-align: right;">dry coil wet coil</p> <p>Supply External Static _____</p> <p>Return External Static _____</p> <p>Total External Static = _____</p> <p>⑥ ELECTRIC HEAT AMPS _____</p> <p>⑦ INDOOR BLOWER AMPS _____</p> <p>INDOOR BLOWER CFM _____</p> <p>⑧ TEMPERATURE DROP (Cooling Mode)</p> <p>Return Duct Temperature _____</p> <p>Supply Duct Temperature - _____</p> <p>Temperature Drop = _____</p> <p>⑧ TEMPERATURE RISE (Heating Mode)</p> <p>Return Duct Temperature _____</p> <p>Supply Duct Temperature - _____</p> <p>Temperature Rise = _____</p> <p>⑨ THERMOSTAT</p> <p><input type="checkbox"/> Adjusted and Programmed</p> <p><input type="checkbox"/> Operation Explained to Owner</p> |
|-------------------------------------------------------------------------------------------------------------------------------------------------------------------------------------------------------------------------------------------------------------------------------------------------------------------------------------------------------------------------------------------------------------------------------------------------------------------------------------------------------------------------------------------------------------------------------------------------------------------------------------------------------------------------------------------------------------------------------------------------------------------------------------------------------------------------------------------------------------------------------|---------------------------------------------------------------------------------------------------------------------------------------------------------------------------------------------------------------------------------------------------------------------------------------------------------------------------------------------------------------------------------------------------------------------------------------------------------------------------------------------------------------------------------------------------------------------------------------------------------------------------------------------------------------------------------------------------------------------------------------------------------------------------------------------------------------|

Explained Operation of System to Homeowner

Technician's Name: _____ Date Start-Up & Performance Check Completed _____

Figure 31. Start-Up and Performance Checklist (Horizontal Configuration)