

OUTDOOR UNIT

DX6VS***1*A*/DZ6VS***1*A*

OUTDOOR UNIT

INSTALLATION & SERVICE REFERENCE

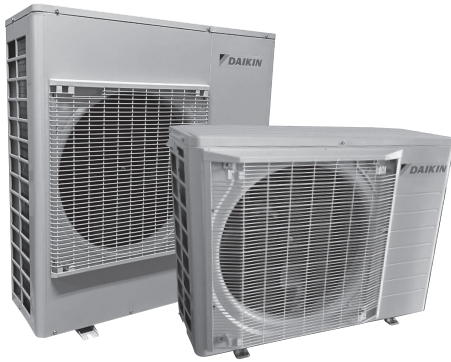

Index

IMPORTANT SAFETY INSTRUCTIONS.....	1
SHIPPING INSPECTION	2
CODES & REGULATIONS	2
FEATURES.....	2
ACCESSORIES	2
BEFORE INSTALLATION	2
PRECAUTIONS FOR SELECTING A LOCATION	3
PRECAUTIONS FOR INSTALLATION	3
INSTALLATION CLEARANCES	4
COLD CLIMATE OUTDOOR UNIT OPERATION LOCATION.....	9
ROOFTOP INSTALLATIONS	9
ELECTRICAL NOISE	9
SAFETY CONSIDERATIONS.....	10
MEANINGS OF SYMBOLS	10
REFRIGERANT LINES.....	12
REFRIGERANT LINE CONNECTIONS.....	16
LEAK TESTING (NITROGEN OR NITROGEN-TRACED)	16
STOP VALVE OPERATION METHOD	17
SYSTEM START-UP PROCEDURE	18
START-UP PROCEDURE DETAIL.....	18
ELECTRICAL CONNECTIONS.....	18
STEP 1. CALCULATE REFRIGERANT CHARGE BASED ON	
LINE SET LENGTH.....	22
STEP 2. CHARGE BY LINESET LENGTH	27
STEP 3. SYSTEM START-UP TEST	27
ADDITIONAL CHARGE ADJUSTING PROCEDURE.....	27
STEP 4. MEASURE SUBCOOLING TO VERIFY PROPER CHARGE	27
SYSTEM OPERATION	28
WIRING DIAGRAM	31
TESTING CAPACITOR RESISTANCE	35
COOLING ANALYSIS CHART.....	37
HEATING ANALYSIS CHART	38
TROUBLESHOOTING	39
SETTING THE MODE DISPLAY.....	44
7-SEGMENT DISPLAY	50
OUTDOOR UNIT HOMEOWNER'S ROUTINE MAINTENANCE	
RECOMMENDATIONS	53
START UP CHECKLIST	54

IMPORTANT SAFETY INSTRUCTIONS

The following symbols and labels are used throughout this manual to indicate immediate or potential safety hazards. It is the owner's and installer's responsibility to read and comply with all safety information and instructions accompanying these symbols. Failure to heed safety information increases the risk of personal injury, property damage, and/or product damage. Also see "Meanings of Symbols" on page 10.

⚠ WARNING

HIGH VOLTAGE !

DISCONNECT ALL POWER BEFORE SERVICING.
MULTIPLE POWER SOURCES MAY BE PRESENT. FAILURE TO DO SO MAY CAUSE PROPERTY DAMAGE, PERSONAL INJURY OR DEATH.



⚠ WARNING

ONLY PERSONNEL THAT HAVE BEEN TRAINED TO INSTALL, ADJUST, SERVICE OR REPAIR (HEREINAFTER, "SERVICE") THE EQUIPMENT SPECIFIED IN THIS MANUAL SHOULD SERVICE THE EQUIPMENT. THE MANUFACTURER WILL NOT BE RESPONSIBLE FOR ANY INJURY OR PROPERTY DAMAGE ARISING FROM IMPROPER SERVICE OR SERVICE PROCEDURES. IF YOU SERVICE THIS UNIT, YOU ASSUME RESPONSIBILITY FOR ANY INJURY OR PROPERTY DAMAGE WHICH MAY RESULT. IN ADDITION, IN JURISDICTIONS THAT REQUIRE ONE OR MORE LICENSES TO SERVICE THE EQUIPMENT SPECIFIED IN THIS MANUAL, ONLY LICENSED PERSONNEL SHOULD SERVICE THE EQUIPMENT. IMPROPER INSTALLATION, ADJUSTMENT, SERVICING OR REPAIR OF THE EQUIPMENT SPECIFIED IN THIS MANUAL, OR ATTEMPTING TO INSTALL, ADJUST, SERVICE OR REPAIR THE EQUIPMENT SPECIFIED IN THIS MANUAL WITHOUT PROPER TRAINING MAY RESULT IN PRODUCT DAMAGE, PROPERTY DAMAGE, PERSONAL INJURY OR DEATH.

⚠ WARNING

THIS APPLIANCE IS NOT INTENDED FOR USE BY PERSONS (INCLUDING CHILDREN) WITH REDUCED PHYSICAL, SENSORY OR MENTAL CAPABILITIES, OR LACK OF EXPERIENCE AND KNOWLEDGE, UNLESS THEY HAVE BEEN GIVEN SUPERVISION OR INSTRUCTION CONCERNING USE OF THE APPLIANCE BY A PERSON RESPONSIBLE FOR THEIR SAFETY.
DO NOT ALLOW CHILDREN TO PLAY ON OR AROUND THE UNIT TO PREVENT INJURY.

**PROP 65 WARNING
FOR CALIFORNIA CONSUMERS**

⚠ WARNING

Cancer and Reproductive Harm -
www.P65Warnings.ca.gov

English
Français
Español

Our continuing commitment to quality products may mean a change in specifications without notice.

© 2013, 2017-2019, 2022 **DAIKIN MANUFACTURING COMPANY, L.P**

Daikin Texas Technology Park, 19001 Kermier Road, Waller, TX, 77484, U.S.A.

www.daikincomfort.com



CAUTION

DO NOT WASH THE OUTDOOR UNIT WITH EXCESSIVE WATER. AN ELECTRIC SHOCK OR FIRE COULD RESULT.

SHIPPING INSPECTION

Always keep the unit upright; laying the unit on its side or top may cause equipment damage. Shipping damage, and subsequent investigation is the responsibility of the carrier. Verify the model number, specifications, electrical characteristics, and accessories are correct prior to installation. The distributor or manufacturer will not accept claims from dealers for transportation damage or installation of incorrectly shipped units.

CODES & REGULATIONS

This product is designed and manufactured to comply with national codes. Installation in accordance with such codes and/or prevailing local codes/regulations is the responsibility of the installer. The manufacturer assumes no responsibility for equipment installed in violation of any codes or regulations. Rated performance is achieved after 20 hours of operation. Rated performance is delivered at the specified airflow. See outdoor unit specification sheet for split system models or product specification sheet for packaged and light commercial models. Specification sheets can be found at www.daikin-comfort.com for Daikin products. Within the website, please select the products menu and then select the submenu for the type of product to be installed, such as air conditioners or heat pumps, to access a list of product pages that each contain links to that model's specification sheet.

The United States Environmental Protection Agency (EPA) has issued various regulations regarding the introduction and disposal of refrigerants. Failure to follow these regulations may harm the environment and can lead to the imposition of substantial fines.

Should you have any questions please contact our local EPA office.

If replacing one of the component of the system, the system must be manufacturer approved and Air Conditioning, Heating and Refrigeration Institute (AHRI) matched.

NOTE: The installation of an inverter outdoor unit with unmatched system units will not allow for proper operation.

NOTICE

INVERTER OUTDOOR UNIT MODELS CAN ONLY BE MATCHED WITH EEV EQUIPPED INDOOR UNIT. DAMAGE RESULTING FROM OPERATION WITH ANY OTHER COMBINATION IS NOT COVERED BY OUR WARRANTIES.

Outdoor inverter units are approved for operation above 0°F in cooling mode and -10°F (RH10%) in heating mode with no additional kit necessary.

Damage resulting from operation of the unit in a structure that is not complete (either as part of new construction or renovation) is not covered by our warranties.

FEATURES

This outdoor unit is part of a system that uses inverter technology to more efficiently remove or add heat and achieve the target comfort conditions. System may ONLY be installed using a Daikin approved communicating thermostat. The Communicating system reduces the number of required thermostat wires, provides additional setup features and enhanced active diagnostics.

NOTICE

ONLY USE DAIKIN APPROVED COMMUNICATING THERMOSTATS.

ACCESSORIES

Name	Installation manual	Warranty card	Insulation tube (clear)
Shape			
1.5 - 3.0 ton (DX6VS*/DZ6VS* 18/24/30/361*)	1	1	
3.5 - 5.0 ton (DX6VS*/DZ6VS* 42/48/601*)	1	1	2

Name	Conduit plate	Clamp	Filter Dryer
Shape			
1.5 - 3.0 ton (DX6VS*/DZ6VS* 18/24/30/361*)		1	1
3.5 - 5.0 ton (DX6VS*/DZ6VS* 42/48/601*)	1 set	1	1

BEFORE INSTALLATION

Precautions to remove packaging (Corner guard)

<3.5 - 5.0 ton only>

- Remove the packaging (Corner guard) used to protect the unit while carrying from the right front part.

Follow the steps below to remove.

- Remove the front plate screw.
- Remove the packaging (Corner guard).
- Install the front plate screw to fix the front and top plates.

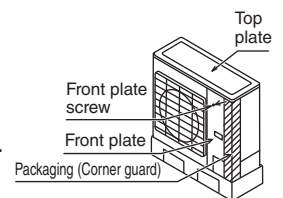

About carrying

Hold the handles as shown in the figure below and move it slowly.

(Pay attention not to touch the fins at the back.)

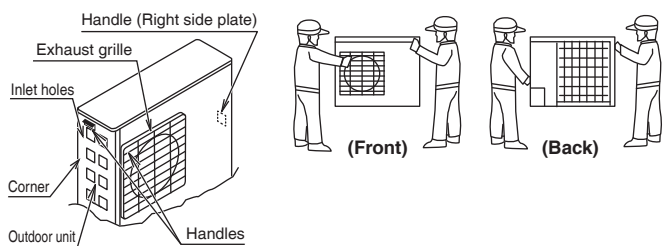

<1.5 - 3.0 ton>

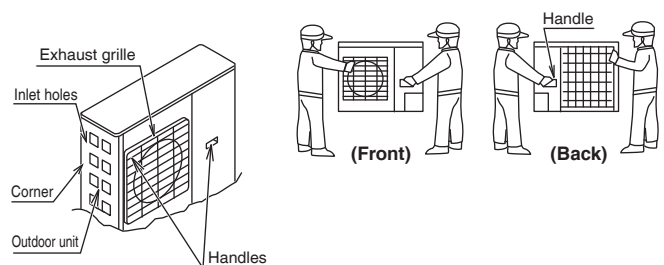

<3.5 - 5.0 ton>

NOTE: Don't place your fingers into the inlet holes of the casing while moving the unit. Failure to do so may result in deformation. Only hold the corner of the unit with your hands.

PRECAUTIONS FOR SELECTING A LOCATION

1. Choose a place solid enough to bear the weight and vibration of the unit, where the operating sound will not be amplified.
2. Choose a location where the hot air discharged from the unit or the operating sound will not cause a nuisance to the neighbours of the user.
3. Avoid places near a bedroom and the like, so that the operating sound will cause no trouble.
4. There must be sufficient spaces for carrying the unit into and out of the site.
5. There must be sufficient space for air passage and no obstructions around the air inlet and the air outlet.
6. The site must be free from the possibility of flammable gas leakage in a nearby place.
7. Do not install the outdoor unit in the following locations:
 - (a) Where a mineral oil mist or oil spray or vapor is produced, for example, in a kitchen.
Plastic parts may deteriorate and fall off and thus may result in water leakage.
 - (b) Where corrosive gas, such as sulfurous acid gas, is produced.
Corroding copper pipes or soldered parts may result in refrigerant leakage.
 - (c) Near machinery emitting electromagnetic waves.
Electromagnetic waves may disturb the operation of the control system and cause the unit to malfunction.
 - (d) Where flammable gas may leak, where there is carbon fiber, or ignitable dust suspension in the air, or where volatile flammables such as thinner or gasoline are handled.
Operating the unit in such conditions may result in a fire.

PRECAUTIONS FOR INSTALLATION

- Check the strength and level of the installation ground so that the unit will not cause any operating vibration or noise after installed.
- Fix the unit securely by means of the foundation bolts. (Prepare 4 sets of foundation bolts (1.5 - 3.0 ton: 3/8" or 7/16", 3.5 - 5.0 ton: 1/2"), nuts and washers; all separately available.)
- It is best to screw in the foundation bolts until their ends are 1 inch from the foundation surface.

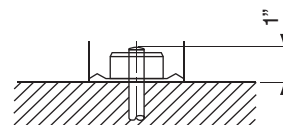

《Drain treatment》

- In a location where drain from the outdoor unit may cause troubles (for example, where drainage may splash on general passersby), perform the drain piping work using the drain plug (optional).
- For drain treatment, space of at least 4 in. is required under the bottom frame of the outdoor unit.
- In case of installing the outdoor unit in cold climates, do not take this centralized drainage way. Otherwise, drain pipe freeze-up and ice build-up on the bottom frame way occur.

INSTALLATION CLEARANCES

- Installation clearances mean required clearances for installation, maintenance and enhancing system performance.
 - The following installation clearances are based on the cooling operation in 95°F ambient condition. In the case systems operate more than 95°F ambient condition or the cooling load is greater than system maximum capacity, it is desirable to leave greater clearance.
 - Working space and ventilation should be considered.
 - Keep more than 10" clearance on the right side of unit for working space.
 - Dimension "H" is the height from the ground to the top of the unit, and dimension "L" is the height of the wall.
- *1 If you put a unit on a stand, any gap between the unit and ground has to be closed to avoid bypassing outlet air.

1.5 - 3.0 ton

One unit installation

unit: inch

Open top installation

1. Wall facing inlet side

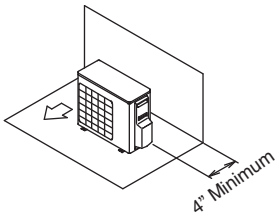

2. Wall facing three side

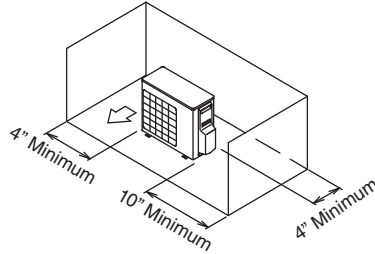

3. Wall facing outlet side

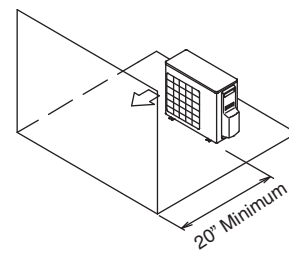

Closed top installation

1. Wall facing inlet side

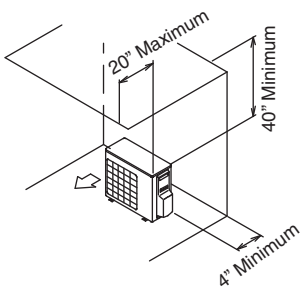

2. Wall facing three side

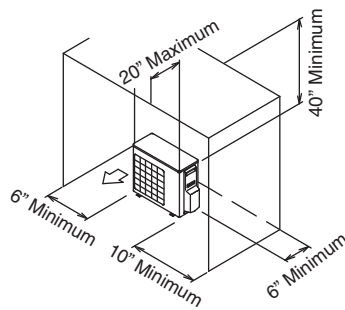

3. Wall facing outlet side

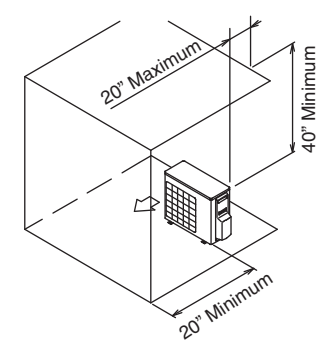

Wall facing inlet and outlet side

- Wall facing outlet side is higher than unit

1. Open top installation

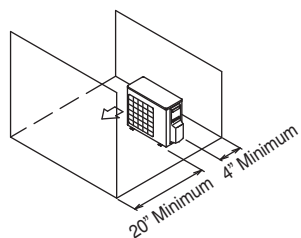

2. Closed top installation*1

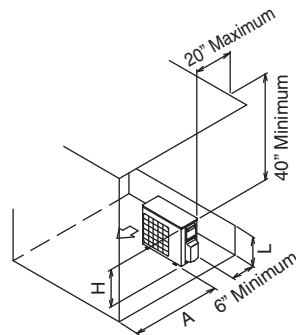

	L	A
L ≤ H	L ≤ 0.5H	30" Minimum
	0.5H < L ≤ H	40" Minimum
L > H	Use a stand to meet L ≤ H. Required dimension A is same as L ≤ H.	

• Wall facing outlet side is lower than unit

unit: inch

1. Open top installation

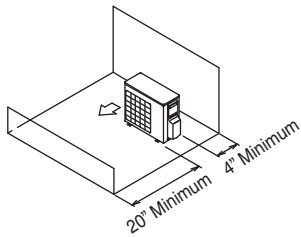

2. Closed top installation*1

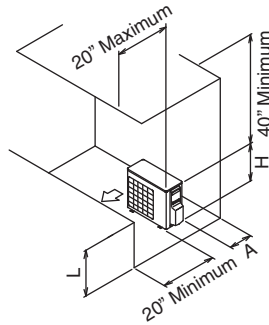

	A	
$L \leq H$	4" Minimum	
$L > H$	Use a stand to meet $L \leq H$ or keep 35" or more clearance to front wall. If using stand, required dimension A is same as $L \leq H$. If not using stand, dimension A is 4" minimum.	

Two units or more installation

Open top installation

1. Wall facing three side

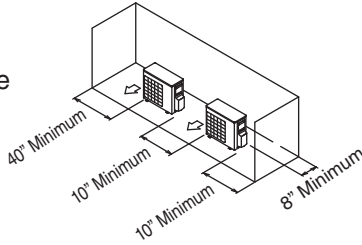

2. Wall facing outlet side

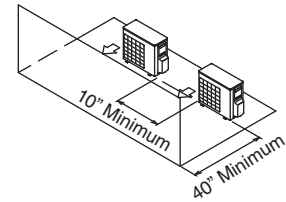

Closed top installation

1. Wall facing outlet side

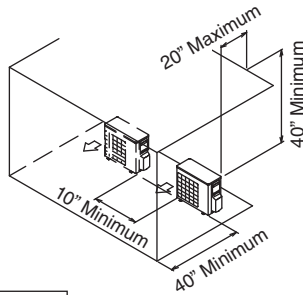

2. Wall facing three side

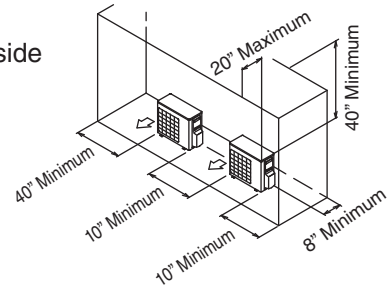

Wall facing inlet and outlet side

• Wall facing outlet side is higher than unit

1. Open top installation

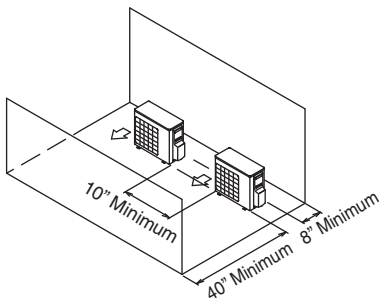

2. Closed top installation*1, *2

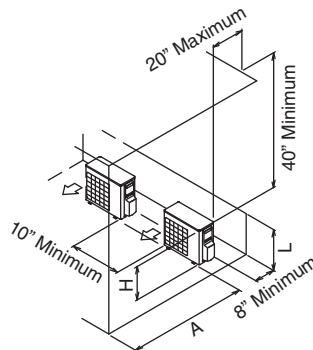

	L	A
$L \leq H$	$L \leq 0.5H$	40" Minimum
	$0.5H < L \leq H$	50" Minimum
$L > H$	Use a stand to meet $L \leq H$. Required dimension A is same as $L \leq H$.	

• Wall facing outlet side is lower than unit

1. Open top installation

L	A
$L \leq 0.5H$	6" Minimum
$0.5H < L \leq H$	8" Minimum

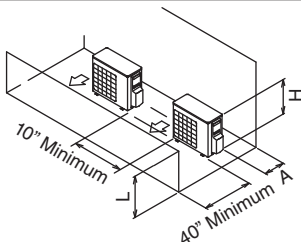

2. Closed top installation*1, *2

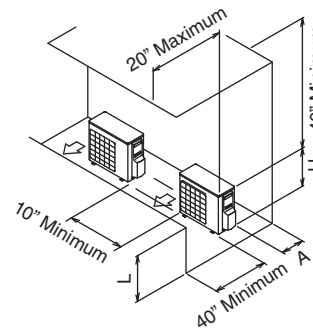

	L	A
$L \leq H$	$L \leq 0.5H$	6" Minimum
	$0.5H < L \leq H$	8" Minimum
$L > H$	Use a stand to meet $L \leq H$ or keep 70" or more clearance to front wall. If using stand, required dimension A is same as $L \leq H$. If not using stand, dimension A is 8" minimum.	

*2 Maximum two units are allowed to install.

Double decker installation

unit: inch

1. Wall facing outlet side

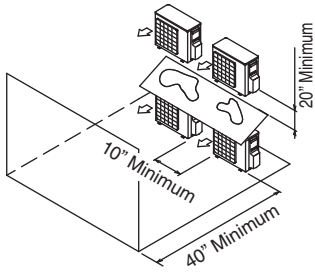

2. Wall facing inlet side

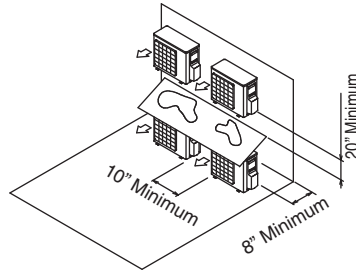

Note:

- Do not stack more than two units.
- If drain water might freeze, install the roof between the units.
- To avoid frost under the bottom frame, leave 20" minimum clearance between the units.

Multiple rows of series installation

(There is no restriction on the height of the wall.)

1. One row of stand alone installation

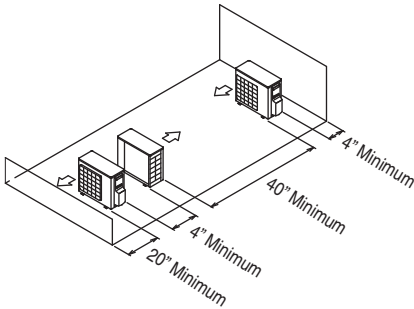

2. Rows of series installation (2 or more)

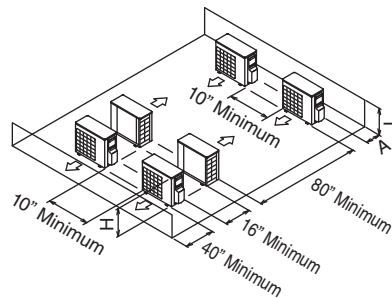

	L	A
L ≤ H	L ≤ 0.5H	6" Minimum
	0.5H < L ≤ H	8" Minimum
L > H	Not available.	

Note:

- Do not install inlet side and outlet side face to face.

3.5 - 5.0 ton

One unit installation

unit: inch

Open top installation

1. Wall facing inlet side

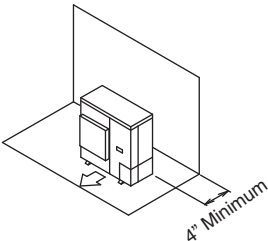

2. Wall facing three side

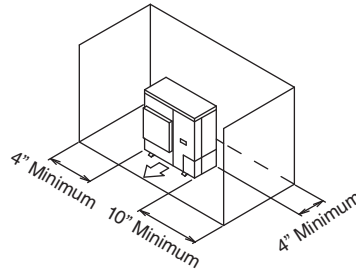

3. Wall facing outlet side

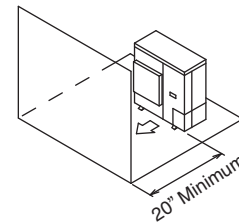

Closed top installation

1. Wall facing inlet side

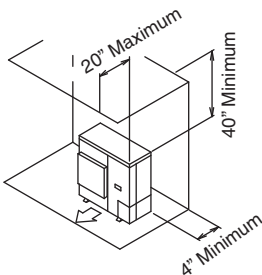

2. Wall facing three side

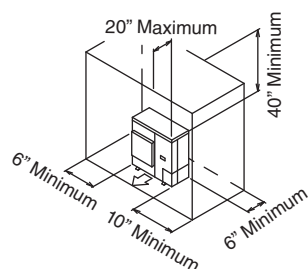

3. Wall facing outlet side

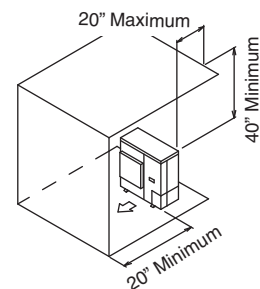

Wall facing inlet and outlet side

unit: inch

• Wall facing outlet side is higher than unit

1. Open top installation

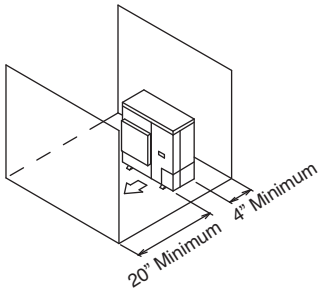

2. Closed top installation*1

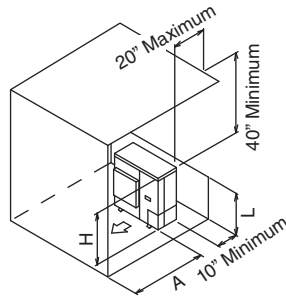

	L	A
$L \leq H$	$L \leq 0.5H$	30" Minimum
	$0.5H < L \leq H$	40" Minimum
$L > H$	Use a stand to meet $L \leq H$. Required dimension A is same as $L \leq H$.	

• Wall facing outlet side is lower than unit

1. Open top installation

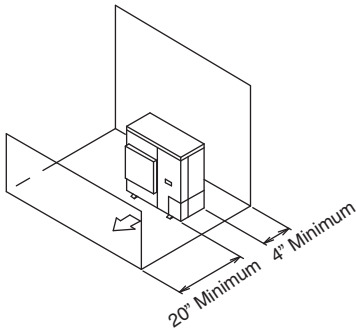

2. Closed top installation*1

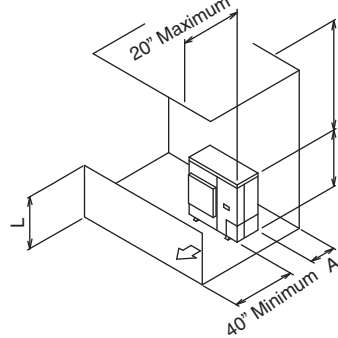

	L	A
$L \leq H$	$L \leq 0.5H$	4" Minimum
	$0.5H < L \leq H$	8" Minimum
$L > H$	Use a stand to meet $L \leq H$ or keep 70" or more clearance to front wall. If using stand, required dimension A is same as $L \leq H$. If not using stand, dimension A is 8" minimum.	

Two units or more installation

Open top installation

1. Wall facing three side

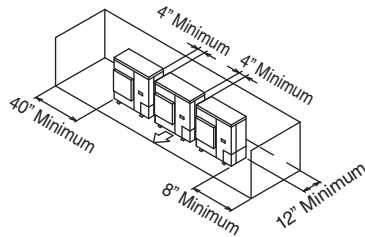

2. Wall facing outlet side

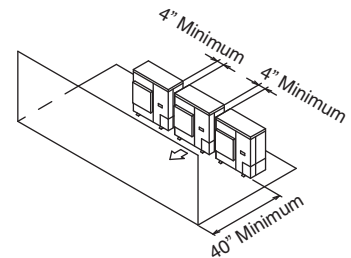

Closed top installation

1. Wall facing outlet side

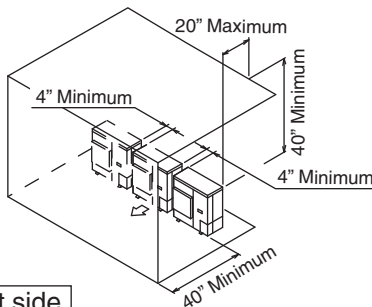

2. Wall facing three side

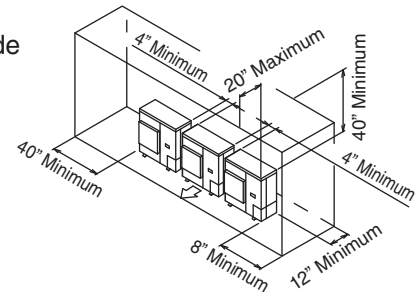

Wall facing inlet and outlet side

• Wall facing outlet side is higher than unit

1. Open top installation

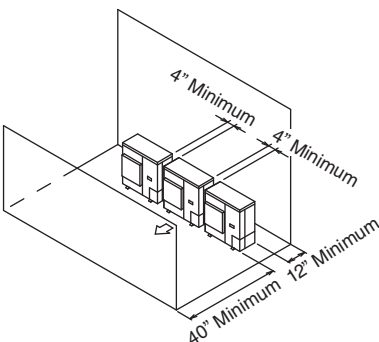

2. Closed top installation*1, *2

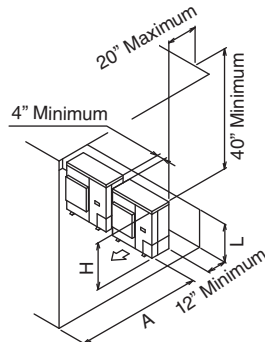

	L	A
$L \leq H$	$L \leq 0.5H$	40" Minimum
	$0.5H < L \leq H$	50" Minimum
$L > H$	Use a stand to meet $L \leq H$. Required dimension A is same as $L \leq H$.	

*2 Maximum two units are allowed to install.

• Wall facing outlet side is lower than unit

unit: inch

1. Open top installation

L	A
$L \leq 0.5H$	10" Minimum
$0.5H < L \leq H$	12" Minimum

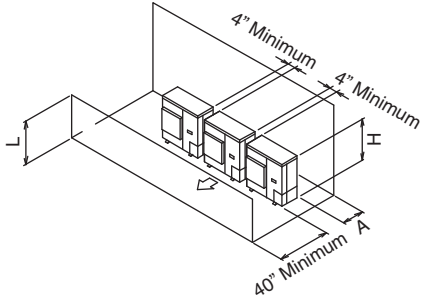

2. Closed top installation*1, *2

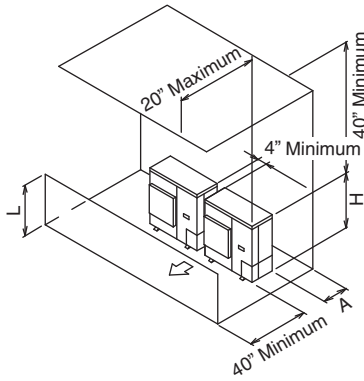

	L	A
$L \leq H$	$L \leq 0.5H$	10" Minimum
	$0.5H < L \leq H$	12" Minimum
$L > H$	Use a stand to meet $L \leq H$ or keep 70" or more clearance to front wall. If using stand, required dimension A is same as $L \leq H$. If not using stand, dimension A is 12" minimum.	

Double decker installation

1. Wall facing outlet side

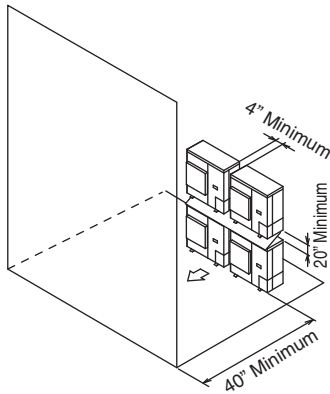

2. Wall facing inlet side

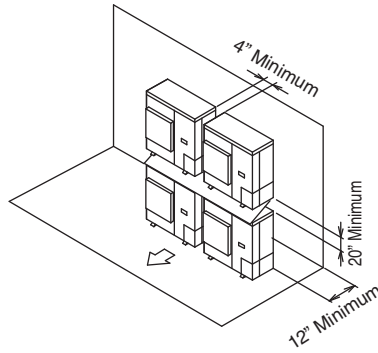

Note:

- Do not stack more than two units.
- If drain water might freeze, install the roof between the units.
- To avoid frost under the bottom frame, leave 20" minimum clearance between the units.

Multiple rows of series installation

(There is no restriction on the height of the wall.)

1. One row of stand alone installation

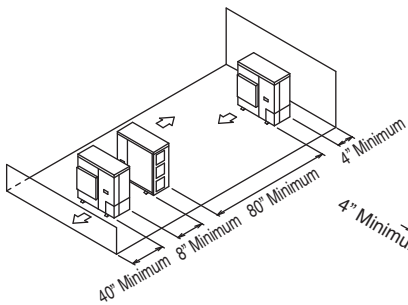

2. Rows of series installation*1 (2 or more)

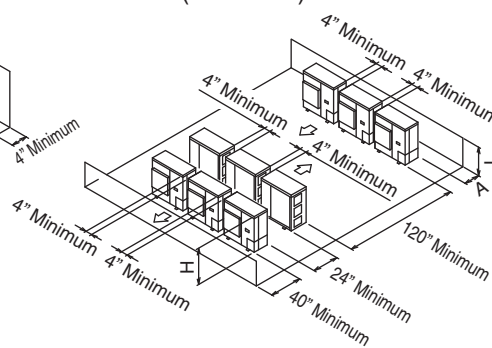

	L	A
$L \leq H$	$L \leq 0.5H$	10" Minimum
	$0.5H < L \leq H$	12" Minimum
$L > H$	Not available.	

Note:

- Do not install inlet side and outlet side face to face.

*2 Maximum two units are allowed to install.

This unit can be located at ground floor level or on flat roofs. At ground floor level, the unit must be on a solid, level foundation that will not shift or settle. To reduce the possibility of sound transmission, the foundation slab should not be in contact with or be an integral part of the building foundation. Care should be taken to ensure the unit is installed away from noise sensitive locations such as bedrooms, windows and outdoor living areas. Ensure the foundation is sufficient to support the unit. A concrete slab raised above ground level provides a suitable base.

COLD CLIMATE OUTDOOR UNIT OPERATION LOCATION

When installing the unit in a place frequently exposed to snow, pay special attention to the following:

- Install the outdoor unit on a stand (field supply), so that the bottom frame is more than 19 3/4 in. (500 mm) higher than the expected snow fall to prevent it from being covered by snow.
- Attach a snow hood (field supply) and a snow vizor (field supply).
- Avoid installation at the place where a snowdrift is generated.
- Further, perform the following countermeasures, since there is risk that the drain water produced at the defrost operation freezes.
- An optional drain pan heater is available when the unit is installed in a climate where the drain may freeze.
- It is highly recommended to use drain pan heater in areas where the outside air temperature drops below 32°F (0°C) for more than 12 hours continuously.
- In high humidity areas or heavy snow areas, it is recommended to attach a drain pan heater to prevent ice build-up from the bottom frame.
- Do not use a concentrated drain pipe. (If so there is a risk of freezing.) Only utilize the existing holes for drainage.
- In high humidity areas or heavy snow areas, it is strongly recommended to install the unit high enough off of the ground to prevent ice build-up from the ground or to prevent burying in snow.
- Remove the rear inlet grille to prevent snow from accumulating on the rear fins.

CAUTION

WHEN OPERATING THE OUTDOOR UNIT IN A LOW OUTDOOR AMBIENT TEMPERATURE, BE SURE TO FOLLOW THE INSTRUCTIONS DESCRIBED BELOW.

- TO PREVENT EXPOSURE TO WIND, INSTALL THE OUTDOOR UNIT WITH ITS SUCTION SIDE FACING THE WALL.
- NEVER INSTALL THE OUTDOOR UNIT AT A SITE WHERE THE SUCTION SIDE MAY BE EXPOSED DIRECTLY TO WIND.
- TO PREVENT EXPOSURE TO WIND, IT IS RECOMMENDED TO INSTALL A BAFFLE PLATE ON THE AIR DISCHARGE SIDE OF THE OUTDOOR UNIT.
- IN HEAVY SNOWFALL AREAS, SELECT AN INSTALLATION SITE WHERE THE SNOW WILL NOT AFFECT THE UNIT.

- Construct a large canopy.
- Construct a pedestal.



Install the unit high enough off the ground to prevent burying in snow.

ROOFTOP INSTALLATIONS

If it is necessary to install this unit on a roof structure, ensure the roof structure can support the weight and that proper consideration is given to the weather-tight integrity of the roof. Since the unit can vibrate during operation, sound vibration transmission should be considered when installing the unit. Vibration absorbing pads or springs can be installed between the outdoor unit legs or frame and the roof mounting assembly to reduce noise vibration.

ELECTRICAL NOISE

The unit should be well grounded so that potential effects of electrical noise from the inverter to surrounding equipment can be minimized.

When selecting an installation location, keep sufficient distance from the outdoor unit and wiring to radios, personal computers, stereos, fluorescent lamp, etc., as shown in the following figure.

Also keep communication wiring 2" away from high voltage power cable to avoid communication error due to noise.

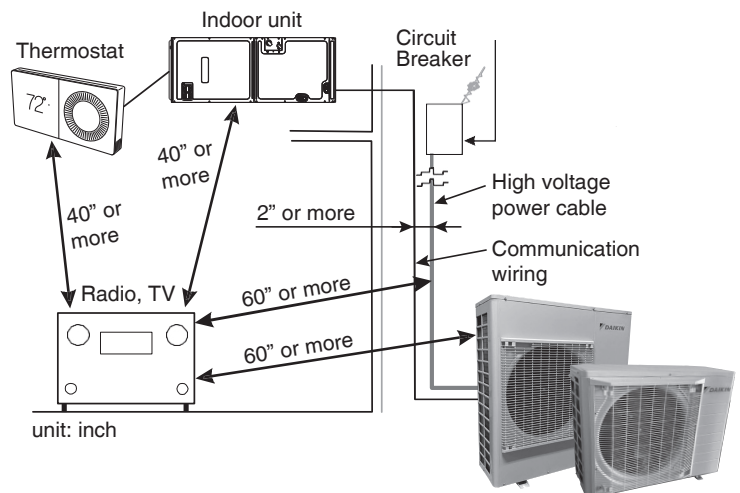

Placement to Minimize Electronic Noise

SAFETY CONSIDERATIONS

Read these Safety considerations for Installation carefully before installing a outdoor unit. After completing the installation, make sure that the unit operates properly during the system start-up operation.

Instruct the customer on how to operate and maintain the unit. Inform customers that they should store this Installation Manual for future reference.

Always use a licensed installer or contractor to install this product.

Improper installation can result in water or refrigerant leakage, electrical shock, fire, or explosion.

MEANINGS OF SYMBOLS

 **WARNING** Indicates imminently or potentially hazardous situation which, if not avoided, will result in death or serious injury.

 **CAUTION** Indicates a potentially hazardous situation which, if not avoided, may result in minor or moderate injury. It may also be used to alert against unsafe practices.

NOTICE Indicates situations that may result in equipment or property-damage accidents only.

While these items will not cover every conceivable situation, they should serve as a useful guide.



WARNING

TO AVOID POSSIBLE INJURY, EXPLOSION OR DEATH, PRACTICE SAFE HANDLING OF REFRIGERANTS.



WARNING

REFRIGERANTS ARE HEAVIER THAN AIR. THEY CAN "PUSH OUT" THE OXYGEN IN YOUR LUNGS OR IN ANY ENCLOSED SPACE. TO AVOID POSSIBLE DIFFICULTY IN BREATHING OR DEATH:

- NEVER PURGE REFRIGERANT INTO AN ENCLOSED ROOM OR SPACE. BY LAW, ALL REFRIGERANTS MUST BE RECLAIMED.
- IF AN INDOOR LEAK IS SUSPECTED, THOROUGHLY VENTILATE THE AREA BEFORE BEGINNING WORK.
- LIQUID REFRIGERANT CAN BE VERY COLD. TO AVOID POSSIBLE FROST BITE OR BLINDNESS, AVOID CONTACT AND WEAR GLOVES AND GOGGLES. IF LIQUID REFRIGERANT DOES CONTACT YOUR SKIN OR EYES, SEEK MEDICAL HELP IMMEDIATELY.
- IF REFRIGERANT GAS LEAKS DURING INSTALLATION, VENTILATE THE AREA IMMEDIATELY. REFRIGERANT GAS WILL RESULT IN PRODUCING TOXIC GAS IF IT COMES INTO CONTACT WITH FIRE. EXPOSURE TO THIS GAS WILL RESULT IN SEVERE INJURY OR DEATH.
- AFTER COMPLETING THE INSTALLATION WORK, CHECK THAT THE REFRIGERANT GAS DOES NOT LEAK THROUGHOUT THE SYSTEM.
- DO NOT INSTALL UNIT IN AN AREA WHERE FLAMMABLE MATERIALS ARE PRESENT DUE TO RISK OF EXPLOSIONS THAT WILL RESULT IN SERIOUS INJURY OR DEATH.
- WHEN INSTALLING THE UNIT IN A SMALL ROOM, TAKE MEASURES TO KEEP THE REFRIGERANT CONCENTRATION FROM EXCEEDING ALLOWABLE SAFETY LIMITS. EXCESSIVE REFRIGERANT LEAKS, IN THE EVENT OF AN ACCIDENT IN A CLOSED AMBIENT SPACE, COULD RESULT IN OXYGEN DEFICIENCY.
- ALWAYS FOLLOW EPA REGULATIONS. NEVER BURN REFRIGERANT, AS POISONOUS GAS WILL BE PRODUCED.



WARNING

TO AVOID POSSIBLE EXPLOSION, USE ONLY RETURNABLE (NOT DISPOSABLE) SERVICE CYLINDERS WHEN REMOVING REFRIGERANT FROM A SYSTEM.

- ENSURE THE CYLINDER IS FREE OF DAMAGE WHICH COULD LEAD TO A LEAK OR EXPLOSION.
 - ENSURE THE CYLINDER HYDROSTATIC TEST DATE DOES NOT EXCEED 5 YEARS.
 - ENSURE THE CYLINDER PRESSURE RATING MEETS OR EXCEEDS 400 PSIG.
- WHEN IN DOUBT, DO NOT USE CYLINDER.



WARNING

TO AVOID POSSIBLE EXPLOSION:

- NEVER APPLY FLAME OR STEAM TO A REFRIGERANT CYLINDER. IF YOU MUST HEAT A CYLINDER FOR FASTER CHARGING, PARTIALLY IMMERSE IT IN WARM WATER.
- NEVER FILL A CYLINDER MORE THAN 80% FULL OF LIQUID REFRIGERANT.
- NEVER ADD ANYTHING OTHER THAN R-410A TO A RETURNABLE R-410A CYLINDER. THE SERVICE EQUIPMENT USED MUST BE LISTED OR CERTIFIED FOR THE TYPE OF REFRIGERANT USE.
- STORE CYLINDERS IN A COOL, DRY PLACE. NEVER USE A CYLINDER AS A PLATFORM OR A ROLLER.



CAUTION

- **REFRIGERANT R410A** IN THE SYSTEM MUST BE KEPT CLEAN, DRY, AND TIGHT.
 - (a) **CLEAN AND DRY - FOREIGN MATERIALS** (INCLUDING MINERAL OILS SUCH AS **SUNISO** OIL OR MOISTURE) SHOULD BE PREVENTED FROM GETTING INTO THE SYSTEM.
 - (b) **TIGHT - R410A** DOES NOT CONTAIN ANY CHLORINE, DOES NOT DESTROY THE OZONE LAYER, AND DOES NOT REDUCE THE EARTH'S PROTECTION AGAIN HARMFUL ULTRAVIOLET RADIATION. **R410A** CAN CONTRIBUTE TO THE GREENHOUSE EFFECT IF IT IS RELEASED. **THEREFORE TAKE PROPER MEASURES TO CHECK FOR THE TIGHTNESS OF THE REFRIGERANT PIPING INSTALLATION. READ THE CHAPTER REFRIGERANT PIPING AND FOLLOW THE PROCEDURES.**
- **SINCE R410A** IS A BLEND, THE REQUIRED ADDITIONAL REFRIGERANT MUST BE CHARGED IN ITS LIQUID STATE. **IF THE REFRIGERANT IS CHARGED IN A STATE OF GAS, ITS COMPOSITION CAN CHANGE AND THE SYSTEM WILL NOT WORK PROPERLY.**



WARNING

- **DO NOT GROUND UNITS TO WATER PIPES, SUCTION LINE, TELEPHONE WIRES, OR LIGHTNING RODS AS INCOMPLETE GROUNDING WILL RESULT A SEVERE SHOCK HAZARD RESULTING IN SEVERE INJURY OR DEATH. AD-
DITIONALLY, GROUNDING TO GAS PIPES WILL RESULT A GAS LEAK AND
POTENTIAL EXPLOSION RESULTING IN SEVERE INJURY OR DEATH.**
- **SAFELY DISPOSE ALL PACKING AND TRANSPORTATION MATERIALS IN AC-
CORDANCE WITH FEDERAL/STATE/LOCAL LAWS OR ORDINANCES. PACK-
ING MATERIALS SUCH AS NAILS AND OTHER METAL OR WOOD PARTS,
INCLUDING PLASTIC PACKING MATERIALS USED FOR TRANSPORTATION
WILL RESULT IN INJURIES OR DEATH BY SUFFOCATION.**
- **ONLY QUALIFIED PERSONNEL MUST CARRY OUT THE INSTALLATION
WORK. INSTALLATION MUST BE DONE IN ACCORDANCE WITH THIS
INSTALLATION MANUAL. IMPROPER INSTALLATION COULD RESULT IN
WATER LEAKAGE, ELECTRIC SHOCK, OR FIRE.**
- **USE ONLY SPECIFIED ACCESSORIES AND PARTS FOR INSTALLATION
WORK. FAILURE TO USE SPECIFIED PARTS COULD RESULT IN WATER
LEAKAGE, ELECTRIC SHOCKS, FIRE, OR THE UNIT FALLING.**
- **INSTALL THE OUTDOOR UNIT ON A FOUNDATION STRONG ENOUGH THAT
IT CAN WITHSTAND THE WEIGHT OF THE UNIT. A FOUNDATION OF INSUF-
FICIENT STRENGTH COULD RESULT IN THE UNIT FALLING AND CAUSING
INJURIES.**
- **TAKE INTO ACCOUNT STRONG WINDS, HURRICANE, OR EARTHQUAKES
WHEN INSTALLING. IMPROPER INSTALLATION COULD RESULT IN THE UNIT
FALLING AND CAUSING ACCIDENTS.**
- **MAKE SURE THAT A SEPARATE POWER SUPPLY CIRCUIT IS PROVIDED
FOR THIS UNIT AND THAT ALL ELECTRICAL WORK IS CARRIED OUT
BY QUALIFIED PERSONNEL ACCORDING TO LOCAL, STATE AND NA-
TIONAL REGULATIONS. AN INSUFFICIENT POWER SUPPLY CAPACITY OR
IMPROPER ELECTRICAL CONSTRUCTION COULD RESULT IN ELECTRIC
SHOCKS OR FIRE.**
- **MAKE SURE THAT ALL WIRING IS SECURED, THAT SPECIFIED WIRES ARE
USED, AND THAT NO EXTERNAL FORCES ACT ON THE TERMINAL CON-
NECTIONS OR WIRES. IMPROPER CONNECTIONS OR INSTALLATION COULD
RESULT IN FIRE.**
- **WHEN WIRING, POSITION THE WIRES SO THAT THE SIDE PLATE WHICH
COVERS TERMINAL BLOCK OF POWER CABLE CAN BE SECURELY FAS-
TENED. IMPROPER POSITIONING OF THE SIDE PLATE COULD RESULT IN
ELECTRIC SHOCKS, FIRE, OR THE TERMINALS OVERHEATING.**
- **DO NOT CHANGE THE SETTING OF THE PROTECTION DEVICES. IF THE
PRESSURE SWITCH, THERMAL SWITCH, OR OTHER PROTECTION DEVICE
IS SHORTED AND OPERATED FORCIBLY, OR PARTS OTHER THAN THOSE
SPECIFIED BY DAIKIN ARE USED, FIRE OR EXPLOSION COULD RESULT.**



CAUTION

- **DO NOT TOUCH THE SWITCH WITH WET FINGERS. TOUCHING A SWITCH WITH WET FINGERS MAY RESULT IN ELECTRIC SHOCK.**
- **DO NOT ALLOW CHILDREN TO PLAY ON OR AROUND THE UNIT OR IT MAY RESULT IN INJURY.**
- **THE HEAT EXCHANGER FINS ARE SHARP ENOUGH TO CUT, AND MAY RESULT IN INJURY IF IMPROPERLY USED. TO AVOID INJURY WEAR GLOVE OR COVER THE FINS WHEN WORKING AROUND THEM.**
- **DO NOT TOUCH THE REFRIGERANT PIPES DURING AND IMMEDIATELY AFTER OPERATION AS THE REFRIGERANT PIPES MAY BE HOT OR COLD, DEPENDING ON THE CONDITION OF THE REFRIGERANT FLOWING THROUGH THE REFRIGERANT PIPING, COMPRESSOR, AND OTHER REFRIGERANT CYCLE PARTS. IT MAY RESULT IN YOUR HANDS GETTING BURNS OR FROSTBITE IF YOU TOUCH THE REFRIGERANT PIPES. TO AVOID INJURY, GIVE THE PIPES TIME TO RETURN TO NORMAL TEMPERATURE OR, IF YOU MUST TOUCH THEM, BE SURE TO WEAR PROPER GLOVES.**
- **INSULATE SUCTION PIPING TO PREVENT CONDENSATION.**
- **BE CAREFUL WHEN TRANSPORTING THE PRODUCT.**
- **TAKE ADEQUATE MEASURES TO PREVENT THE OUTDOOR UNIT FROM BEING USED AS A SHELTER BY SMALL ANIMALS. SMALL ANIMALS MAKING CONTACT WITH ELECTRICAL PARTS MAY RESULT IN MALFUNCTIONS, SMOKE, OR FIRE. INSTRUCT THE CUSTOMER TO KEEP THE AREA AROUND THE UNIT CLEAN.**

NOTICE

- **IF THE CONVENTIONAL REFRIGERANT AND REFRIGERATOR OIL ARE MIXED IN R410A, DETERIORATION WILL RESULT.**
- **THIS OUTDOOR UNIT IS AN APPLIANCE THAT SHOULD NOT BE ACCESSIBLE TO THE GENERAL PUBLIC.**
- **AS DESIGN PRESSURE IS 450 PSIG (3.1 MPa), THE WALL THICKNESS OF FIELD-INSTALLED PIPES SHOULD BE SELECTED IN ACCORDANCE WITH THE RELEVANT LOCAL, STATE, AND NATIONAL REGULATIONS.**

REFRIGERANT LINES



CAUTION

THE COMPRESSOR PVE OIL FOR R-410A UNITS IS EXTREMELY SUSCEPTIBLE TO MOISTURE ABSORPTION AND COULD CAUSE COMPRESSOR FAILURE. DO NOT LEAVE SYSTEM OPEN TO ATMOSPHERE ANY LONGER THAN NECESSARY FOR INSTALLATION.

Use only refrigerant grade (dehydrated and sealed) copper tubing to connect the outdoor unit with the indoor unit. After cutting the tubing, install plugs to keep refrigerant tubing clean and dry prior to and during installation. Tubing should always be cut square keeping ends round and free from burrs. Clean the tubing to prevent contamination. The liquid line must be insulated if more than 50 ft. of liquid line will pass through an area that may reach temperatures of 30°F or higher than outdoor ambient in cooling mode and/or if the temperature inside the conditioned space may reach a temperature lower than outdoor ambient in heating mode. Never attach a liquid line to any uninsulated portion of the suction line.

Do NOT let refrigerant lines come in direct contact with plumbing, ductwork, floor joists, wall studs, floors, and walls. When running refrigerant lines through a foundation or wall, openings should allow for sound and vibration absorbing material to be placed or installed between tubing and foundation. Any

gap between foundation or wall and refrigerant lines should be filled with a pliable silicon-based caulk, RTV or a vibration damping material. Avoid suspending refrigerant tubing from joists and studs with rigid wire or straps that would come in contact with the tubing. Use an insulated or suspension type hanger. Keep both lines separate and always insulate the suction line.

Insulation is necessary to prevent condensation from forming and dropping from the suction line. Insulation tube with 3/8" min. wall thickness is recommended. In severe conditions (likely to exceed 86°F and a relative humidity of 80%) 1/2" insulation may be required. Insulation must be installed in a manner which protects tubing and connections from damage and contamination.

Please use a HVAC flushing solvent to clean lineset of any oil or debris from the existing system.

Cond Unit Tons	Allowable line set diameter						
	Liquid				Suction		
	1/4	5/16	3/8	5/8	3/4	7/8	1 1/8
1.5	x	x	x	x*	x		
2		x	x	x*	x		
2.5		x	x		x*	x	
3		x	x		x*	x	
3.5			x			x	x
4			x			x	x
5			x			x	x

x: Allowable combination

*: For marked combinations, if normal ambient operation temperature is less than 14°F, limit line set length to 50 ft. max.

For line set length, refer to the table on page 22-26.

Refrigerant tubing is highly prone to transmit noise and vibration to the adjoining structure. When mounting line set to structural members, use adequate vibration-isolating hardware.

Installation of Refrigeration Piping From Vertical to Horizontal

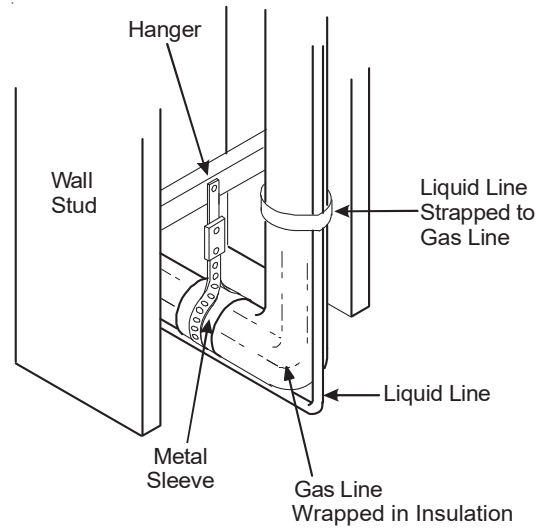

Installation of Refrigerant Piping (Vertical)

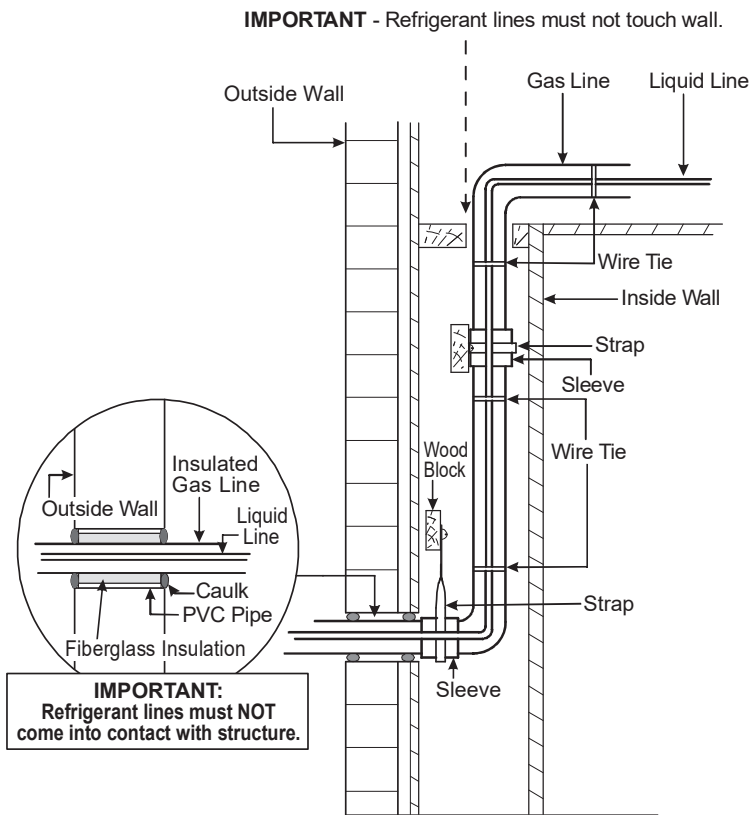

NOTE: If line set is installed on the exterior of an outside wall, similar installation practices are to be used.

Installation of Refrigerant Piping (Horizontal)

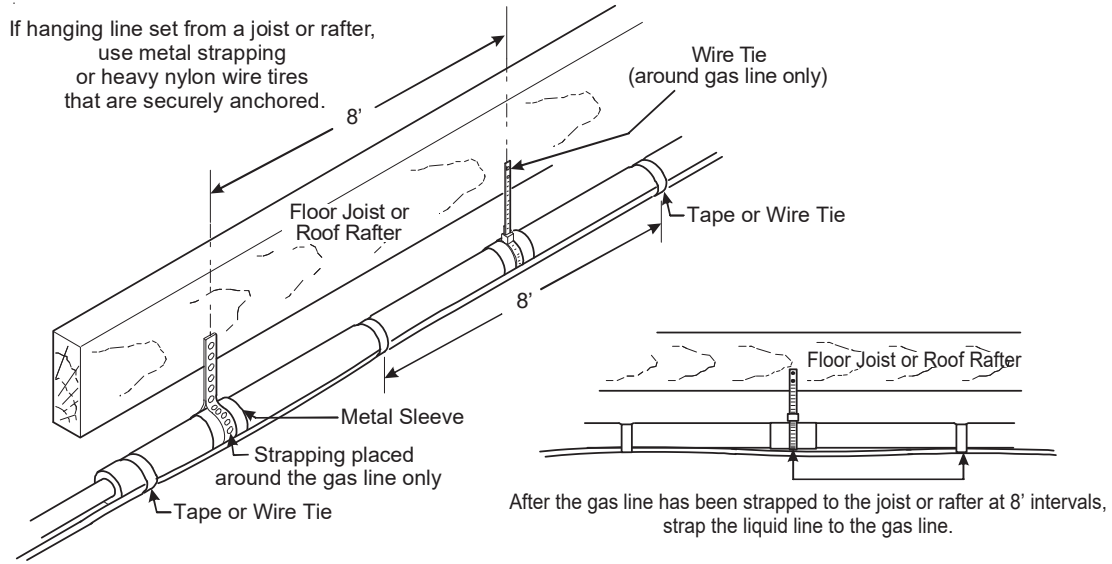

Outdoor Unit BELOW Indoor Unit

Mounting the indoor unit above the outdoor unit will require an inverted loop in the suction line adjacent or near the connection to the indoor unit. The top of the loop must be slightly higher than the top of the unit. The trap can prevent liquid compression of the compressor for start-up period.

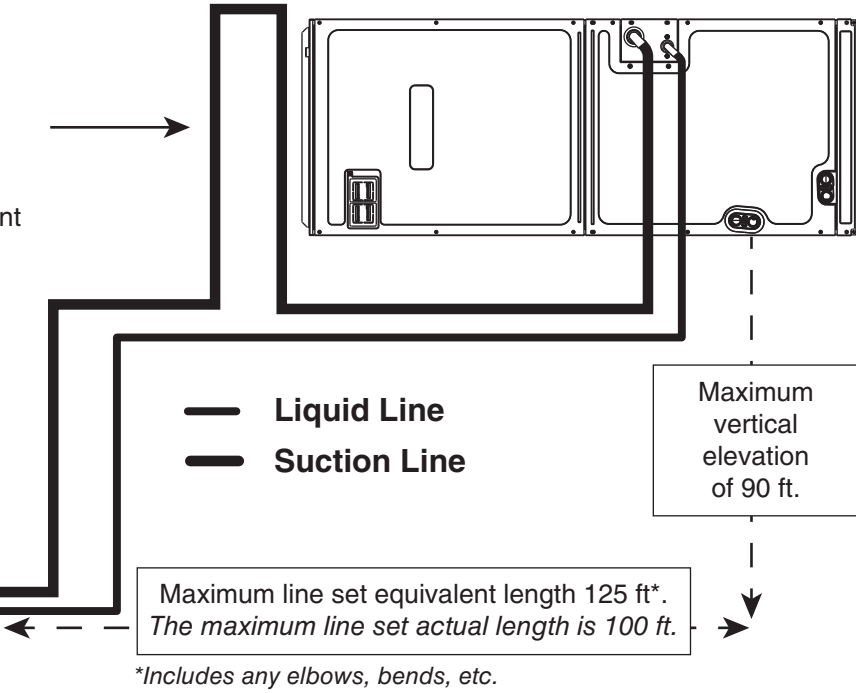

Outdoor Unit ABOVE Indoor Unit

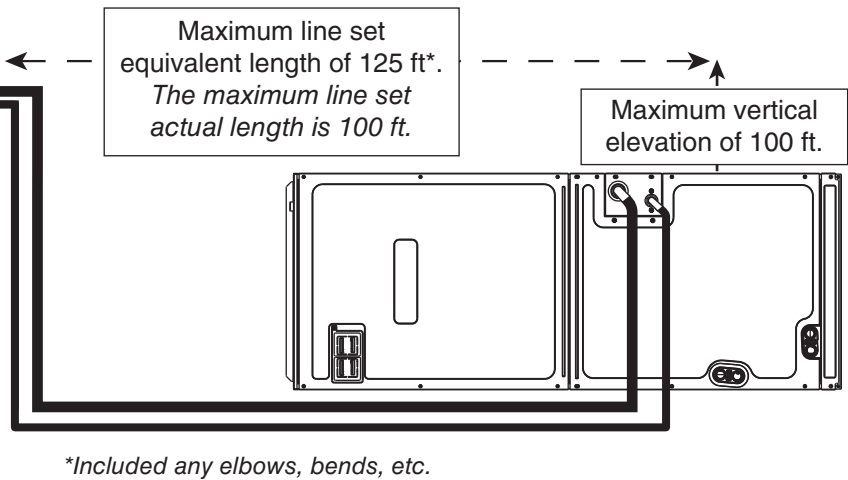
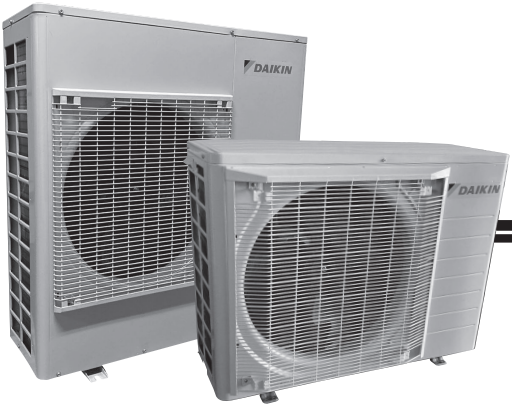

EQUIVALENT LENGTH CALCULATION

NOTE: The following table lists the equivalent length gained from adding bends to the suction line. Properly size the suction line to minimize capacity loss.

Type of Elbow Fitting	Inside Diameter		
	3/4	7/8	1 1/8
90° short radius	1.7"	2"	2.3"
90° long radius	1.5"	1.7"	1.6"
45° radius	0.7"	0.8"	1"

unit: inch

REFRIGERANT LINE CONNECTIONS

IMPORTANT

To avoid overheating the service valve, sensors, or filter drier while brazing, wrap the component with a wet rag, or use a thermal heat trap compound. If using a wet rag care should be taken to not get water/moisture inside the tubing as it's very important to keep moisture out of the system. Be sure to follow the manufacturer's instruction when using the heat trap compound.

Note: Remove Schrader valves from service valves before brazing tubes to the valves. After brazing temperature is reached, use a brazing alloy of 2% minimum silver content. Do not use flux.

Torch heat required to braze tubes of various sizes is proportional to the size of the tube. Tubes of smaller size require less heat to bring the tube to brazing temperature before adding brazing alloy. Applying too much heat to any tube can melt the tube. Service personnel must use the appropriate heat level for the size of the tube being brazed.

NOTE: The use of a heat shield when brazing is recommended to avoid burning the serial plate or the finish on the unit.

1. The ends of the refrigerant lines must be cut square, deburred, cleaned, and be round and free from nicks or dents. Any other condition increases the chance of a refrigerant leak.
2. Purge with nitrogen at 2 to 3 PSIG during brazing to prevent the formation of copper-oxide inside the refrigerant lines. The PVE oils used in R-410A applications will clean any copper-oxide present from the inside of the refrigerant lines and spread it throughout the system. This may cause a blockage or failure of the metering device.
3. During and after brazing, quench the joints with water or a wet cloth to prevent overheating of the service valve.
4. A bi-flow filter drier is shipped with the unit as a separate component and must be brazed on by the installer on-site. Ensure the bi-flow filter drier paint finish is intact after brazing. If the paint of the steel filter drier has been burned or chipped, repaint or treat with a rust inhibitor.

The recommended location of the filter drier is before the expansion device at the indoor unit.

NOTE: Be careful not to kink or dent refrigerant lines. Kinked or dented lines will cause poor performance or compressor damage.

Do NOT make final refrigerant line connection until plugs are removed from refrigerant tubing.

NOTE: Preventing foreign objects from entering.

- Plug the pipe through-holes with accessory set or putty (field supply) to cover all gaps.
- Insects or small animals may enter inside of outdoor units and cause damage to the electrical components.

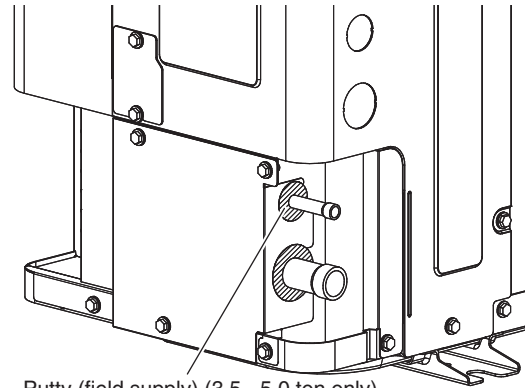

LEAK TESTING (NITROGEN OR NITROGEN-TRACED)

! WARNING

TO AVOID THE RISK OF FIRE OR EXPLOSION, NEVER USE OXYGEN, HIGH PRESSURE AIR OR FLAMMABLE GASES FOR LEAK TESTING OF A REFRIGERATION SYSTEM.

! WARNING

TO AVOID POSSIBLE EXPLOSION, THE LINE FROM THE NITROGEN CYLINDER MUST INCLUDE A PRESSURE REGULATOR AND A PRESSURE RELIEF VALVE. THE PRESSURE RELIEF VALVE MUST BE SET TO OPEN AT NO MORE THAN 450 PSIG.

To locate leaks, test system pressure using dry nitrogen or use leak detector fluid per Daikin's recommendation and check for leak. If you wish to use a leak detector.

- Charge the system to 10 PSIG using the appropriate refrigerant.
- Use nitrogen to finish charging the system to working pressure.
- Apply the detector to suspect areas.

If leaks are found, repair them. After repair, repeat the pressure test. If no leaks exist, proceed to **System Start-up Procedure**.

STANDING PRESSURE TEST

Best practices dictate system should be pressure tested at 450 PSIG with nitrogen for a minimum 4 hours. Follow the procedure outlined below to test system. If leaks are found, repair them. After repair, repeat the leak pressure test described above. If no leaks exist, proceed to system evacuation and charging.

SYSTEM PRESSURE TESTING (RECOMMENDED)

Once all of the refrigerant line connections are completed. Perform a 3-step nitrogen pressure test.

1. Pressurize the system with nitrogen to 150 PSIG and hold for 3 minutes. If any pressure drops occur, locate and repair leaks and repeat step 1.
2. Pressurize the system with nitrogen to 325 PSIG and hold for 5 minutes. If any pressure drops occur, locate and repair leaks and repeat step 1.
3. Pressurize the system with nitrogen to 450 PSIG and hold for 4 hours. If any pressure drops occur, locate and repair leaks and repeat step 1.

STOP VALVE OPERATION METHOD

The figure below shows the name of each part required in handling the stop valve. At the time of shipment, the stop valve is closed.

CAUTION

- BE SURE TO OPEN THE STOP VALVE.
- INADEQUATE TORQUE MAY CAUSE LEAKAGE OF REFRIGERANT.

Opening Procedure

1. Remove the valve lid and use a hexagonal wrench to turn valve counterclockwise.
2. Turn valve until shaft stops.
3. Then turn valve until designated torque as shown in below table is achieved (3.5 - 5.0 ton only due to back sealing type valve).
4. Put valve lid on valve.

Closing Procedure

1. Remove the valve lid and use a hexagonal wrench to turn valve clockwise.
2. Turn valve until shaft stops.
3. Then turn valve until designated torque as shown in below table is achieved.
4. Put valve lid on valve.

<1.5 - 3.0 ton>

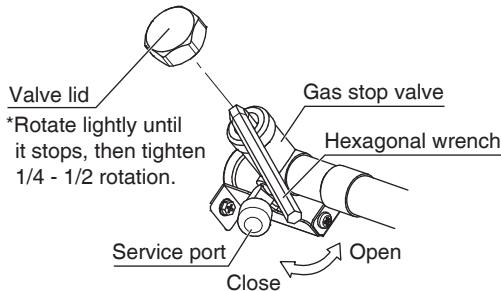

<3.5 - 5.0 ton>

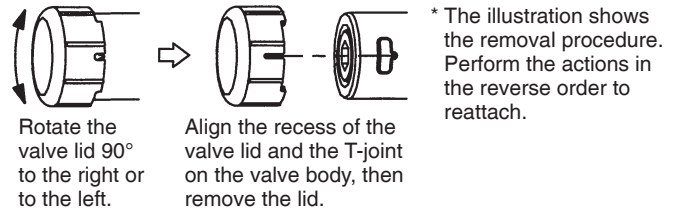
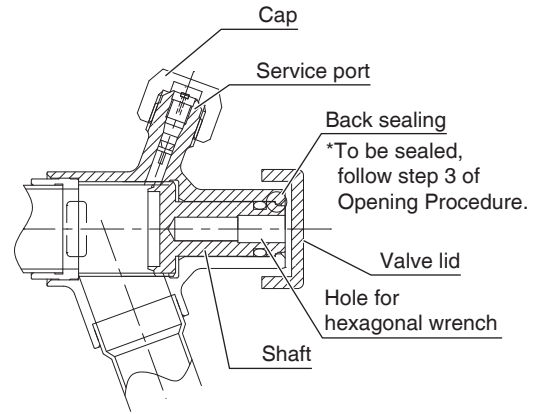
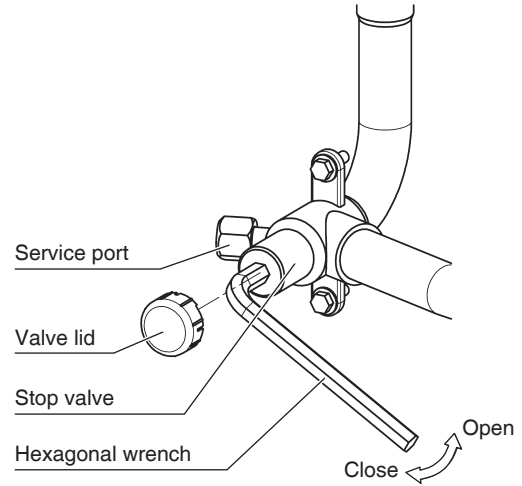

* The illustrations above refer to 3.5 - 5.0 ton only.

Stop Valve

Tonnage	Piping	Stop valve size	Type	Tightening torque	Wrench size
1.5 - 2.0 ton	Liquid	3/8"	Front sealing type	4 - 6 lb-ft	3/16"
	Gas	3/4"		14 - 16 lb-ft	5/16"
2.5 - 3.0 ton	Liquid	3/8"		4 - 6 lb-ft	3/16"
	Gas	7/8"		14 - 16 lb-ft	5/16"
3.5 - 5.0 ton	Liquid	3/8"	Front and back sealing type	4 - 5 lb-ft	4 mm
	Gas	7/8"		14 - 16 lb-ft	8 mm

Service Port

	Tighten Torque
Service Port (3.5 - 5.0 ton only)	7.9 - 10.8 lb-ft

SYSTEM START-UP PROCEDURE

GENERAL NOTES:

Adequate refrigerant charge for the matching indoor unit and line set is supplied with the outdoor unit. If liquid line set exceeds factory charge length, refrigerant should be added based on liquid line. Refer pages 22-26 for calculation of refrigerant charge based on line set length.

NOTICE

VIOLATION OF EPA REGULATIONS MAY RESULT IN FINES OR OTHER PENALTIES.

NOTICE

ALL UNITS SHOULD HAVE A HIGH VOLTAGE POWER SUPPLY CONNECTED 2 HOURS PRIOR TO STARTUP.



WARNING

REFRIGERANT UNDER PRESSURE!

- Do NOT OVERCHARGE SYSTEM WITH REFRIGERANT.
 - Do NOT OPERATE UNIT IN A VACUUM OR AT NEGATIVE PRESSURE.
- FAILURE TO FOLLOW PROPER PROCEDURES MAY CAUSE PROPERTY DAMAGE, PERSONAL INJURY OR DEATH.



CAUTION

OPERATING THE COMPRESSOR WITH THE SUCTION VALVE CLOSED WILL CAUSE SERIOUS COMPRESSOR DAMAGE - SUCH DAMAGE IS NOT COVERED BY OUR WARRANTIES.



CAUTION

USE REFRIGERANT CERTIFIED TO AHRI STANDARDS. USED REFRIGERANT MAY CAUSE COMPRESSOR DAMAGE, AND IS NOT COVERED UNDER THE WARRANTY. MOST PORTABLE MACHINES CANNOT CLEAN USED REFRIGERANT TO MEET AHRI STANDARDS.

START-UP PROCEDURE DETAIL

Outdoor unit liquid and suction valves are closed to contain the charge within the unit. The unit is shipped with the valve stems closed and caps installed. **Do not open valves until the indoor unit and line set is evacuated.**



CAUTION

PROLONGED OPERATION AT SUCTION PRESSURES LESS THAN 20 PSIG FOR MORE THAN 5 SECONDS WILL RESULT IN OVERHEATING OF THE COMPRESSOR AND MAY CAUSE PERMANENT DAMAGE TO IT.

1. Connect the vacuum pump with 250 micron capability to the service valves.
2. Evacuate the system to 500 microns or less using suction and liquid service valves. Using both valves is necessary.
3. Close pump valve and hold vacuum for 10 minutes. Typically pressure will rise during this period.
 - If the pressure rises to 500 microns or less and remains steady the system is considered leak-free; proceed to start-up.

- If pressure rises above 500 microns moisture and/or noncondensibles may be present or the system may have a small leak. Return to step 2: If the same result is encountered check for leaks as previously indicated and repair as necessary then repeat evacuation.

THE TRIPLE EVACUATION METHOD IS (RECOMMENDED)

1. Evacuate the system to 4000 microns and hold for 15 minutes. Then, break the vacuum with dry nitrogen. Bring the system pressure up to 2-3 PSIG and hold for 20 minutes. Release the nitrogen.
2. Evacuate to 1500 microns and hold for 20 minutes. Break the vacuum with dry nitrogen again. Bring the system pressure back up to 2-3 PSIG and hold for 20 minutes.
3. Then, evacuate the system until it is below 500 microns and hold for 60 minutes.

ELECTRICAL CONNECTIONS



WARNING

HIGH VOLTAGE!

DISCONNECT ALL POWER BEFORE SERVICING. MULTIPLE POWER SOURCES MAY BE PRESENT. FAILURE TO DO SO MAY CAUSE PROPERTY DAMAGE, PERSONAL INJURY OR DEATH DUE TO ELECTRIC SHOCK. WIRING MUST CONFORM WITH NEC OR CEC AND ALL LOCAL CODES. UNDERSIZED WIRES COULD CAUSE POOR EQUIPMENT PERFORMANCE, EQUIPMENT DAMAGE OR FIRE.



WARNING

TO AVOID THE RISK OF FIRE OR EQUIPMENT DAMAGE, USE COPPER CONDUCTORS.



CAUTION

GROUNDING REQUIRED!

ALWAYS INSPECT AND USE PROPER SERVICE TOOLS. LACK OF INSPECTION OR IMPROPER TOOLS MAY CAUSE EQUIPMENT DAMAGE OR PERSONAL INJURY. ALL DISCONNECTED GROUNDING DEVICES **MUST** BE RECONNECTED BEFORE INSTALLING OR SERVICING. MULTIPLE COMPONENTS OF THIS UNIT MAY CONDUCT ELECTRICAL CURRENT; THESE ARE GROUNDED. IF SERVICING THE UNIT, ANY DISCONNECTION OF GROUNDING WIRES, SCREWS, STRAPS, CLIPS, NUTS OR WASHERS USED TO COMPLETE THE GROUND **MUST** BE RETURNED TO THEIR ORIGINAL POSITION AND PROPERLY FASTENED.

NOTICE

- NEVER INSTALL A PHASE-ADVANCING CAPACITOR. AS THIS UNIT IS EQUIPPED WITH AN INVERTER, INSTALLING A PHASE-ADVANCING CAPACITOR WILL NOT ONLY DETERIORATE POWER FACTOR IMPROVEMENT EFFECT, BUT ALSO MAY CAUSE CAPACITOR ABNORMAL HEATING ACCIDENT DUE TO HIGH-FREQUENCY WAVES.
- Do NOT CHANGE THE SETTING OF THE PROTECTION DEVICES. IF THE PRESSURE SWITCH, THERMAL SWITCH, OR OTHER PROTECTION DEVICE IS SHORTED AND OPERATED FORCIBLY, OR PARTS OTHER THAN THOSE SPECIFIED BY DAIKIN ARE USED, FIRE OR EXPLOSION COULD RESULT.
- Do NOT CONNECT THE GROUND WIRE TO GAS LINE, SEWAGE PIPES, LIGHTNING RODS, OR TELEPHONE GROUND WIRES.

HIGH VOLTAGE CONNECTIONS

Route power supply and ground wires through the high voltage port and terminate in accordance with the wiring diagram.

CAUTION

- **BEFORE CONNECTING THE WIRING TO THE TERMINAL BLOCK, REMOVE THE SHIELDING PLATE. AND TAKE IT BACK AFTER WORKING. (3.5 - 5.0 TON ONLY)**

- **PRECAUTIONS TO BE TAKEN FOR POWER SUPPLY WIRING.**

WHEN USING STRANDED WIRES, MAKE SURE TO USE A ROUND CRIMP-STYLE TERMINAL FOR CONNECTION TO THE POWER SUPPLY TERMINAL BLOCK.

PLACE THE ROUND CRIMP-STYLE TERMINALS ON THE WIRES UP TO THE COVERED PART AND SECURE IN PLACE.

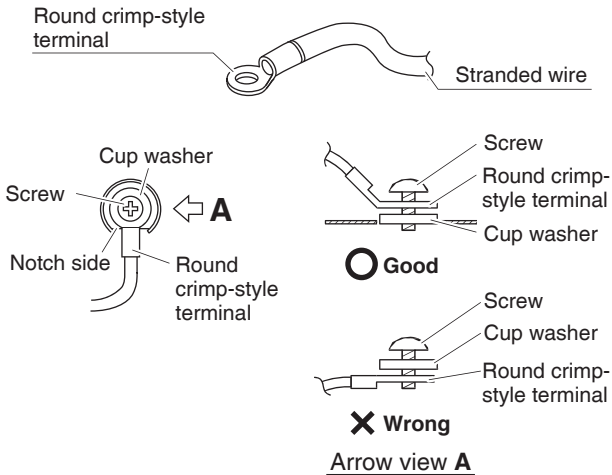

- **WHEN CONNECTING THE CONNECTION WIRES TO THE TERMINAL BLOCK USING A SINGLE CORE WIRE, BE SURE TO CURL THE END OF THE LEAD. IMPROPER WORK MAY CAUSE HEAT AND FIRES.**

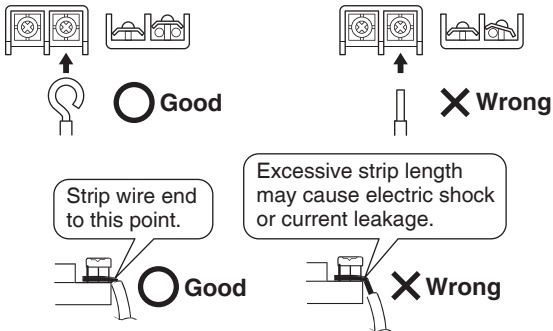

- **USE THE FOLLOWING METHOD WHEN INSTALLING A SINGLE CORE WIRE.**

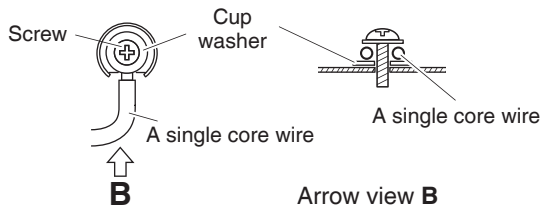

- **FOR WIRING, USE THE DESIGNATED POWER WIRE AND CONNECT FIRMLY, THEN SECURE TO PREVENT OUTSIDE PRESSURE BEING EXERTED ON THE TERMINAL BOARD.**

- **USE AN APPROPRIATE SCREWDRIVER FOR TIGHTENING THE TERMINAL SCREWS.**

A SCREWDRIVER WITH A SMALL HEAD WILL STRIP THE HEAD AND MAKE PROPER TIGHTENING IMPOSSIBLE.

- **OVER-TIGHTENING THE TERMINAL SCREWS MAY BREAK THEM.**
- **SEE THE TABLE BELOW FOR TIGHTENING TORQUE FOR THE TERMINAL SCREWS.**

Tightening torque (lb-ft)		
M4	Power supply wire for 1.5 - 3.0 Ton	0.87 - 1.06
M5	Power supply wire for 3.5 - 5.0 Ton	1.76 - 2.15
M5	Ground wire	2.23 - 3.01

- Make sure to apply the rated voltage of 208/230V for the unit.
- Use conduit for power supply cables.
- A power circuit (see the following table) must be provided for connection of the unit. This circuit must be protected with the required safety devices.
- When using residual current operated circuit breakers, be sure to use a high-speed type (0.1 seconds or less) 200 mA rated residual operating current.
- Use copper conductors only.
- Use insulated wire for the power cord.
- Select the power supply cable type and size in accordance with relevant local and national regulations.
- Make sure the wirings will not be pinched by the front panel, and close the panel firmly.
- Route the conduit along the unit by using a elbow socket and so on to prevent it from being stepped on.
- The appliance incorporates grounding connections for functional purpose in addition to protective ground.

MODEL NAME	Phase and frequency	Voltage	MCA (Min. circuit amp.)	MOP (Max. overcurrent protective device)	Communication selection
DX6VS*181*	1 Phase 60Hz	208/230V	14.6 A	15 A	18 AWG (typical)
DX6VS*241*			18.8 A	20 A	
DX6VS*301*			23.9 A	25 A	
DX6VS*361*			23.9 A	25 A	
DX6VS*421*			34.4 A	35 A	
DX6VS*481*			34.4 A	35 A	
DX6VS*601*			36.2 A	40 A	
DZ6VS*181*	1 Phase 60Hz	208/230V	14.6 A	15 A	18 AWG (typical)
DZ6VS*241*			18.8 A	20 A	
DZ6VS*301*			23.9 A	25 A	
DZ6VS*361*			23.9 A	25 A	
DZ6VS*421*			34.4 A	35 A	
DZ6VS*481*			34.4 A	35 A	
DZ6VS*601*			36.2 A	40 A	

The outdoor unit rating plate lists pertinent electrical data necessary for proper electrical service and overcurrent protection. Wires should be sized to limit voltage drop to 2% (max.) from the main breaker or fuse panel to the outdoor unit. Refer the NEC, CEC, and all local codes to determine the correct wire gauge and length.

Local codes often require a disconnect switch located near the unit; do not install the switch on the unit.

LOW VOLTAGE CONNECTIONS

The unit is designed to work as part of a fully communicating HVAC system, utilizing a Daikin approved communicating thermostat, Communicating indoor unit, and up to four wires. Route control wires through the low voltage port and terminate in accordance with the wiring diagram provided inside the front plate.

<1.5 - 3.0 ton>

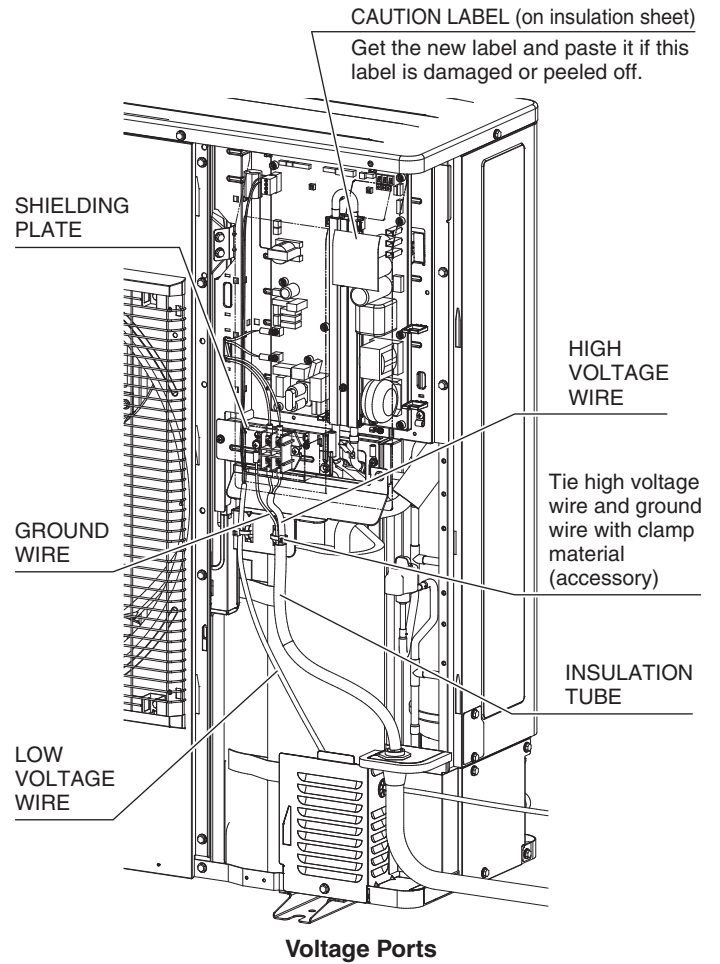
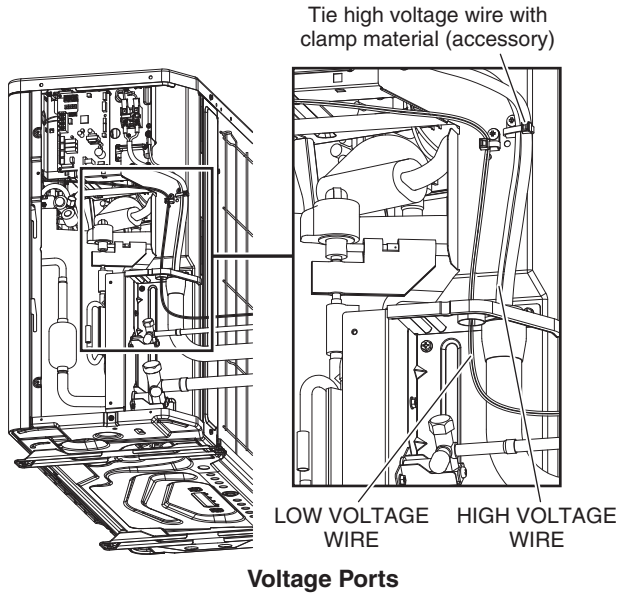

<3.5 - 5.0 ton>

Connect by one of the following options

When using Straight Conduit

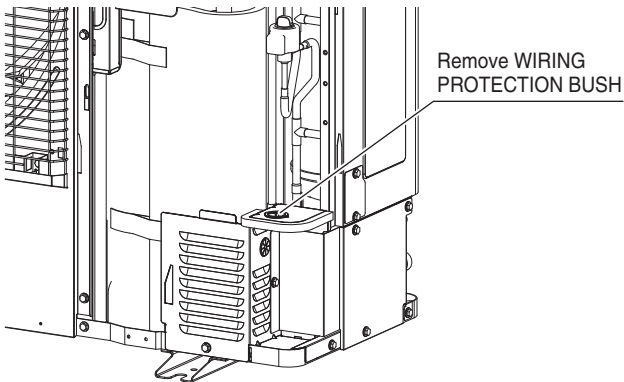

When using Elbow Conduit

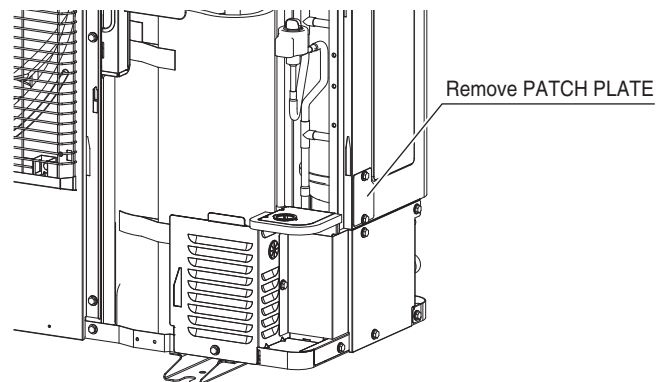

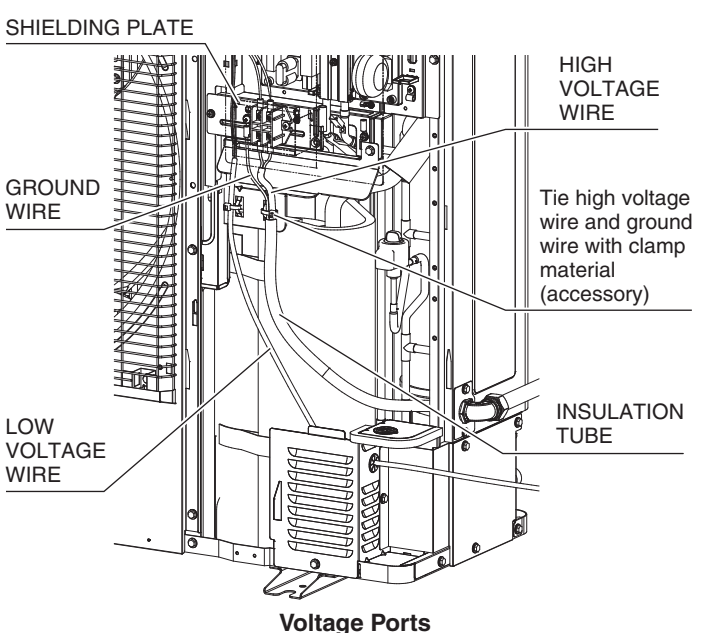
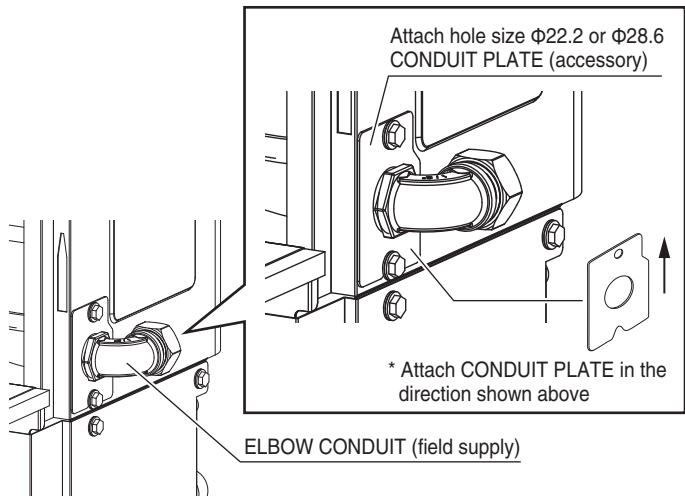

NOTE: The communicating thermostat is able to search and identify the indoor and outdoor units when power is applied to the system. Refer to the communicating thermostat's installation instructions for more information.

Connect low voltage communication wires (1, 2) to low voltage pigtail provided.

COMMUNICATION WIRING

NOTE: A terminal block is attached with the control board to make wiring connections for the thermostat. Connect the wire to the terminal block. (1.5 - 3.0 ton only) A removable plug connector is provided with the control board to make thermostat wire connections. Remove the plug, connect the wires to the plug, and then replace. (3.5 - 5.0 ton only) It is strongly recommended that you do not connect more than two wires into a single terminal in the field because there is a risk of the wires becoming loose, which may result in communication error. Refer to Troubleshooting Tables for error codes.

To wire the system components, it is strongly recommended to use the same type and same gauge for the wires prepared in the field. (For best results, use 18 AWG.) However, communications reliability may be improved by using a high quality,

shielded, twisted pair cable for the data transmission lines. Finally, be sure to confirm that the wires do not come off each terminal after all connections are finished.

NOTE: When connecting the connection wires to the terminal block, be sure to curl the end of the lead.

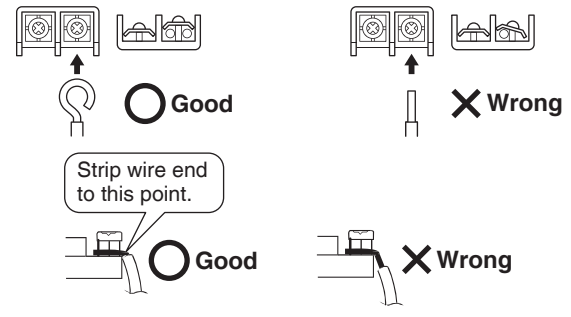

TWO-WIRE OUTDOOR, FOUR-WIRE INDOOR WIRING

Typical wiring will consist of two wires between the indoor unit and outdoor unit, and four wires between the indoor unit and thermostat. The figure that follows shows the required wires: data lines, 1 and 2; "R" (24 VAC hot) and "C" (24 VAC common). Never connect the power wiring to communication terminal. (1, 2, R, C)

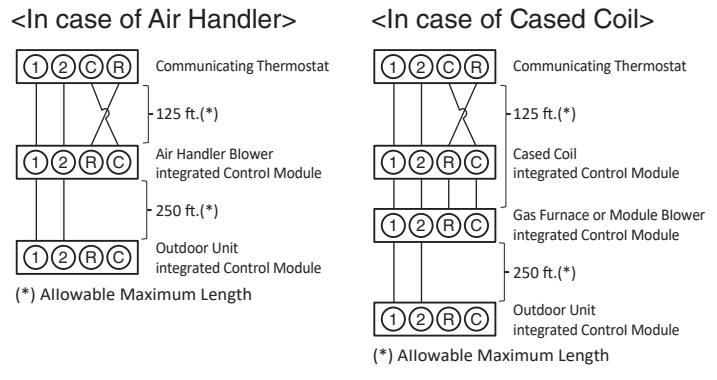

System Wiring

ATTENTION INSTALLER - IMPORTANT NOTICE!

Please read carefully before installing this unit.

- Low voltage terminal C from indoor unit must connect to low voltage terminal C on thermostat and low voltage terminal R from indoor unit must connect to low voltage terminal R on thermostat. Verify wires are not reversed. (Note: The order of the terminals of the indoor unit and your thermostat may be different system wiring.)
- Do not attach any wires to the R & C Terminals on the Outdoor Unit, as they are not needed for inverter unit.
- Data line terminal #1 from outdoor unit must connect to terminal #1 on indoor unit and thermostat and data line terminal #2 from outdoor unit must connect to terminal #2 on indoor unit and thermostat. *Verify wires are not reversed.*

STEP 1. CALCULATE REFRIGERANT CHARGE BASED ON LINE SET LENGTH

The outdoor unit is shipped with a predetermined factory charge level as shown below. Please follow below step. Refer to the following page for the equivalent length of the elbow fittings.

$$\boxed{\text{Total Refrigerant Charge (A)}} = \boxed{\text{Factory Charge (B)*}} + \boxed{\text{Additional Charge for line set (C)}}$$

(A) to (C) parameters are shown in below table.

The following table shows refrigerant amount for every 5 feet of line. Choose connected indoor coil type, Liquid/Suction pipe diameter and line set length. Calculate charge amount by linear approximation in between line set length mentioned below table.

* Factory Charge (B) may differ from the value specified on the unit name plate.

In that case, calculate the Additional Charge (C) as to keep the Total Refrigerant Charge (A) indicated in the table.

Charge Table for Total Refrigerant (A)

AC	Total/Additional refrigerant (oz.)																			
	1.5 ton								2.0 ton											
Indoor Unit type	CAPEA, DFVE, DV**FEC																			
Liquid Pipe Diameter(inch)	1/4"		5/16"				3/8"		5/16"				3/8"							
Suction Pipe Diameter(inch)	5/8"		3/4"		5/8"		3/4"		5/8"		3/4"		5/8"		3/4"					
Actual Line Set Length(ft.)	(A)	(C)	(A)	(C)	(A)	(C)	(A)	(C)	(A)	(C)	(A)	(C)	(A)	(C)	(A)	(C)				
15 or less	n/a		n/a		n/a		n/a		76	0	n/a		n/a		76		0			
20	n/a		n/a		76	0	77	1	79	3	n/a		78	2	77	1	79	3		
25	n/a		77	1	76	0	78	2	80	4	82	6	78	2	80	4	80	4	82	6
30	n/a		78	2	77	1	80	4	83	7	85	9	79	3	82	6	83	7	85	9
35	n/a		79	3	79	3	82	6	85	9	88	12	81	5	84	8	85	9	88	12
40	77	1	81	5	80	4	84	8	88	12	92	16	82	6	86	10	88	12	92	16
45	78	2	82	6	82	6	86	10	91	15	95	19	84	8	88	12	91	15	95	19
50	78	2	83	7	83	7	88	12	93	17	98	22	85	9	89	13	93	17	98	22
55	79	3	84	8	85	9	89	13	96	20	101	25	87	11	91	15	96	20	101	25
60	80	4	85	9	86	10	91	15	99	23	104	28	88	12	93	17	99	23	104	28
65	81	5	86	10	88	12	93	17	101	25	107	31	90	14	95	19	101	25	107	31
70	81	5	87	11	89	13	95	19	104	28	110	34	91	15	97	21	104	28	110	34
75	82	6	88	12	91	15	97	21	107	31	113	37	n/a	n/a	107	31	113	37		
80	83	7	90	14	92	16	99	23	109	33	116	40			109	33	116	40		
85	83	7	91	15	94	18	101	25	112	36	119	43			112	36	119	43		
90	84	8	92	16	95	19	103	27	115	39	123	47			115	39	123	47		
95	85	9	93	17	97	21	105	29	117	41	126	50			117	41	126	50		
100	85	9	94	18	98	22	107	31	120	44	129	53			120	44	129	53		

Factory Charge (B)
Standard Diameter

AC	Total/Additional refrigerant (oz.)															
	2.5 ton								3.0 ton							
Indoor Unit type	CAPEA, DFVE, DV**FEC															
Liquid Pipe Diameter(inch)	5/16"				3/8"				5/16"				3/8"			
Suction Pipe Diameter(inch)	3/4"		7/8"		3/4"		7/8"		3/4"		7/8"		3/4"		7/8"	
Actual Line Set Length(ft.)	(A)	(C)	(A)	(C)	(A)	(C)	(A)	(C)	(A)	(C)	(A)	(C)	(A)	(C)	(A)	(C)
15 or less	n/a		n/a		n/a		79	0	n/a		n/a		n/a		85	0
20	n/a		81	2	80	1	82	3	n/a		87	2	86	1	88	3
25	80	1	83	4	83	4	85	6	86	1	89	4	89	4	91	6
30	82	3	85	6	86	7	89	10	88	3	91	6	92	7	95	10
35	84	5	87	8	89	10	92	13	90	5	93	8	95	10	98	13
40	85	6	89	10	92	13	95	16	91	6	95	10	98	13	101	16
45	87	8	91	12	94	15	99	20	93	8	97	12	100	15	105	20
50	88	9	93	14	97	18	102	23	94	9	99	14	103	18	108	23
55	90	11	95	16	100	21	105	26	96	11	101	16	106	21	111	26
60	92	13	97	18	103	24	108	29	98	13	103	18	109	24	114	29
65	93	14	99	20	105	26	112	33	99	14	105	20	111	26	118	33
70	95	16	101	22	108	29	115	36	101	16	107	22	114	29	121	36
75	n/a		n/a		111	32	118	39	n/a		n/a		117	32	124	39
80					114	35	121	42					120	35	127	42
85					117	38	125	46					123	38	131	46
90					119	40	128	49					125	40	134	49
95					122	43	131	52					128	43	137	52
100					125	46	134	55					131	46	140	55

Factory Charge (B)**Standard Diameter**

AC	Total/Additional refrigerant (oz.)							
	3.5 - 4.0 ton				5.0 ton			
Indoor Unit type	DFVE, DV**FEC							
Liquid Pipe Diameter(inch)	3/8"				3/8"			
Suction Pipe Diameter(inch)	7/8"		1-1/8"		7/8"		1-1/8"	
Actual Line Set Length(ft.)	(A)	(C)	(A)	(C)	(A)	(C)	(A)	(C)
15 or less	n/a		111	0	n/a		131	0
20	111	0	114	3	131	0	134	3
25	112	1	117	6	132	1	137	6
30	114	3	120	9	134	3	140	9
35	117	6	123	12	137	6	143	12
40	119	8	126	15	139	8	146	15
45	121	10	129	18	141	10	149	18
50	123	12	132	21	143	12	152	21
55	125	14	135	24	145	14	155	24
60	127	16	138	27	147	16	158	27
65	129	18	141	30	149	18	161	30
70	131	20	144	33	151	20	164	33
75	133	22	147	36	153	22	167	36
80	135	24	150	39	155	24	170	39
85	137	26	153	42	157	26	173	42
90	139	28	156	45	159	28	176	45
95	142	31	159	48	162	31	179	48
100	144	33	162	51	164	33	182	51

Factory Charge (B)**Standard Diameter**

AC	Total/Additional refrigerant (oz.)																			
	1.5 ton									2.0 ton										
Indoor Unit type	CHPE																			
Liquid Pipe Diameter(inch)	1/4"				5/16"				3/8"				5/16"				3/8"			
Suction Pipe Diameter(inch)	5/8"		3/4"		5/8"		3/4"		5/8"		3/4"		5/8"		3/4"		5/8"		3/4"	
Actual Line Set Length(ft.)	(A)	(C)	(A)	(C)	(A)	(C)	(A)	(C)	(A)	(C)	(A)	(C)	(A)	(C)	(A)	(C)	(A)	(C)	(A)	(C)
12 or less	n/a		n/a		n/a		n/a		n/a		76	0	n/a		n/a		n/a		76	0
15							76	0	76	0	76	0			76	0				
20			77	1	76	0	77	1	79	3	81	5	77	1	79	3	79	3	81	5
25			78	2	77	1	79	3	82	6	84	8	79	3	81	5	82	6	84	8
30			79	3	78	2	81	5	85	9	87	11	80	4	83	7	85	9	87	11
35			77	1	80	4	80	4	83	7	87	11	90	14	82	6	85	9	87	11
40	78	2	81	5	81	5	85	9	90	14	93	17	83	7	87	11	90	14	93	17
45	78	2	82	6	83	7	87	11	93	17	96	20	85	9	89	13	93	17	96	20
50	79	3	83	7	84	8	89	13	95	19	100	24	86	10	91	15	95	19	100	24
55	80	4	85	9	86	10	91	15	98	22	103	27	88	12	93	17	98	22	103	27
60	81	5	86	10	87	11	93	17	101	25	106	30	89	13	94	18	101	25	106	30
65	81	5	87	11	89	13	94	18	103	27	109	33	91	15	96	20	103	27	109	33
70	82	6	88	12	90	14	96	20	106	30	112	36	92	16	98	22	106	30	112	36
75	83	7	89	13	92	16	98	22	109	33	115	39	n/a	n/a	109	33	115	39		
80	83	7	90	14	93	17	100	24	111	35	118	42			111	35	118	42		
85	84	8	91	15	95	19	102	26	114	38	121	45			114	38	121	45		
90	85	9	92	16	96	20	104	28	117	41	124	48			117	41	124	48		
95	85	9	94	18	98	22	106	30	119	43	127	51			119	43	127	51		
100	86	10	95	19	99	23	108	32	122	46	131	55			122	46	131	55		

Factory Charge (B)
Standard Diameter

AC	Total/Additional refrigerant (oz.)																	
	2.5 ton									3.0 ton								
Indoor Unit type	CHPE																	
Liquid Pipe Diameter(inch)	5/16"				3/8"				5/16"				3/8"					
Suction Pipe Diameter(inch)	5/8"		3/4"		5/8"		3/4"		3/4"		7/8"		3/4"		7/8"			
Actual Line Set Length(ft.)	(A)	(C)	(A)	(C)	(A)	(C)	(A)	(C)	(A)	(C)	(A)	(C)	(A)	(C)	(A)	(C)		
12 or less	n/a		n/a		n/a		79	0	n/a		n/a		n/a		85	0		
15					79	0	79	0			79	0	85	0	85	0	85	0
20	80	1	82	3	82	3	84	5	86	1	88	3	88	3	90	5		
25	82	3	84	5	84	5	87	8	88	3	90	5	90	5	93	8		
30	83	4	86	7	88	9	91	12	89	4	92	7	94	9	97	12		
35	85	6	88	9	91	12	94	15	91	6	94	9	97	12	100	15		
40	87	8	90	11	93	14	97	18	93	8	96	11	99	14	103	18		
45	88	9	92	13	96	17	100	21	94	9	98	13	102	17	106	21		
50	90	11	94	15	99	20	104	25	96	11	100	15	105	20	110	25		
55	91	12	96	17	102	23	107	28	97	12	102	17	108	23	113	28		
60	93	14	98	19	105	26	110	31	99	14	104	19	111	26	116	31		
65	94	15	100	21	107	28	113	34	100	15	106	21	113	28	119	34		
70	96	17	102	23	110	31	117	38	102	17	108	23	116	31	123	38		
75	n/a	n/a	113		34	120	41	n/a	n/a	119		34	126	41				
80			116		37	123	44			122		37	129	44				
85			119		40	126	47			125		40	132	47				
90			121		42	130	51			127		42	136	51				
95			124		45	133	54			130		45	139	54				
100			127		48	136	57			133		48	142	57				

Factory Charge (B)
Standard Diameter

AC	Total/Additional refrigerant (oz.)							
	3.5 - 4.0 ton				5.0 ton			
Indoor Unit type	CAPE, CHPE							
Liquid Pipe Diameter(inch)	3/8"				3/8"			
Suction Pipe Diameter(inch)	7/8"		1-1/8"		7/8"		1-1/8"	
Actual Line Set Length(ft.)	(A)	(C)	(A)	(C)	(A)	(C)	(A)	(C)
12 or less	112	1	114	3	135	4	137	6
15	113	2	116	5	136	5	139	8
20	115	4	119	8	138	7	142	11
25	117	6	122	11	140	9	145	14
30	119	8	125	14	142	11	148	17
35	121	10	128	17	144	13	151	20
40	123	12	131	20	146	15	154	23
45	126	15	134	23	149	18	157	26
50	128	17	137	26	151	20	160	29
55	130	19	140	29	153	22	163	32
60	132	21	143	32	155	24	166	35
65	134	23	146	35	157	26	169	38
70	136	25	149	38	159	28	172	41
75	138	27	152	41	161	30	175	44
80	140	29	155	44	163	32	178	47
85	142	31	158	47	165	34	181	50
90	144	33	161	50	167	36	184	53
95	146	35	164	53	169	38	187	56
100	148	37	167	56	171	40	190	59

Factory Charge (B)
Standard Diameter

111

131

HP	Total/Additional refrigerant (oz.)																			
	1.5 ton								2.0 ton											
Indoor Unit type	CAPEA, DFVE, DV**FEC																			
Liquid Pipe Diameter(inch)	1/4"				5/16"				3/8"				5/16"				3/8"			
Suction Pipe Diameter(inch)	5/8"		3/4"		5/8"		3/4"		5/8"		3/4"		5/8"		3/4"		5/8"		3/4"	
Actual Line Set Length(ft.)	(A)	(C)	(A)	(C)	(A)	(C)	(A)	(C)	(A)	(C)	(A)	(C)	(A)	(C)	(A)	(C)	(A)	(C)	(A)	(C)
15 or less	n/a		n/a		n/a		n/a		81	0	81	0	n/a				81	0	81	0
20			81	0	n/a		81	0	82	1	84	3	n/a		83	2	82	1	84	3
25			82	1	81	0	83	2	85	4	87	6	83	2	85	4	85	4	87	6
30	81	0	83	2	82	1	85	4	88	7	90	9	84	3	87	6	88	7	90	9
35	81	0	84	3	84	3	87	6	90	9	93	12	86	5	89	8	90	9	93	12
40	82	1	86	5	85	4	89	8	93	12	97	16	87	6	91	10	93	12	97	16
45	83	2	87	6	87	6	91	10	96	15	100	19	89	8	93	12	96	15	100	19
50	83	2	88	7	88	7	93	12	98	17	103	22	90	9	94	13	98	17	103	22
55	84	3	89	8	90	9	94	13	101	20	106	25	92	11	96	15	101	20	106	25
60	85	4	90	9	91	10	96	15	104	23	109	28	93	12	98	17	104	23	109	28
65	86	5	91	10	93	12	98	17	106	25	112	31	95	14	100	19	106	25	112	31
70	86	5	92	11	94	13	100	19	109	28	115	34	96	15	102	21	109	28	115	34
75	87	6	93	12	96	15	102	21	112	31	118	37	n/a				112	31	118	37
80	88	7	95	14	97	16	104	23	114	33	121	40					114	33	121	40
85	88	7	96	15	99	18	106	25	117	36	124	43					117	36	124	43
90	89	8	97	16	100	19	108	27	120	39	128	47					120	39	128	47
95	90	9	98	17	102	21	110	29	122	41	131	50					122	41	131	50
100	90	9	99	18	103	22	112	31	125	44	134	53					125	44	134	53

Factory Charge (B)
Standard Diameter

HP	Total/Additional refrigerant (oz.)															
	2.5 ton								3.0 ton							
Indoor Unit type	CAPEA, DFVE, DV**FEC															
Liquid Pipe Diameter(inch)	5/16"				3/8"				5/16"				3/8"			
Suction Pipe Diameter(inch)	3/4"		7/8"		3/4"		7/8"		3/4"		7/8"		3/4"		7/8"	
Actual Line Set Length(ft.)	(A)	(C)	(A)	(C)	(A)	(C)	(A)	(C)	(A)	(C)	(A)	(C)	(A)	(C)	(A)	(C)
15 or less	n/a		n/a		88	0	88	0	n/a		n/a		88	0	88	0
20	n/a		90	2	89	1	91	3	n/a		90	2	89	1	91	3
25	89	1	92	4	92	4	94	6	89	1	92	4	92	4	94	6
30	91	3	94	6	95	7	98	10	91	3	94	6	95	7	98	10
35	93	5	96	8	98	10	101	13	93	5	96	8	98	10	101	13
40	94	6	98	10	101	13	104	16	94	6	98	10	101	13	104	16
45	96	8	100	12	103	15	108	20	96	8	100	12	103	15	108	20
50	97	9	102	14	106	18	111	23	97	9	102	14	106	18	111	23
55	99	11	104	16	109	21	114	26	99	11	104	16	109	21	114	26
60	101	13	106	18	112	24	117	29	101	13	106	18	112	24	117	29
65	102	14	108	20	114	26	121	33	102	14	108	20	114	26	121	33
70	104	16	110	22	117	29	124	36	104	16	110	22	117	29	124	36
75	n/a		n/a		120	32	127	39	n/a		n/a		120	32	127	39
80					123	35	130	42					123	35	130	42
85					126	38	134	46					126	38	134	46
90					128	40	137	49					128	40	137	49
95					131	43	140	52					131	43	140	52
100					134	46	143	55					134	46	143	55

Factory Charge (B)
Standard Diameter

HP	Total/Additional refrigerant (oz.)							
	3.5 - 4.0 ton				5.0 ton			
Indoor Unit type	DFVE, DV**FEC							
Liquid Pipe Diameter(inch)	3/8"				3/8"			
Suction Pipe Diameter(inch)	7/8"		1-1/8"		7/8"		1-1/8"	
Actual Line Set Length(ft.)	(A)	(C)	(A)	(C)	(A)	(C)	(A)	(C)
15 or less	n/a		118	0	n/a		127	0
20	118	0	121	3	127	0	130	3
25	120	2	124	6	128	1	133	6
30	124	6	129	11	133	6	138	11
35	127	9	133	15	136	9	142	15
40	130	12	137	19	139	12	146	19
45	134	16	140	22	142	15	149	22
50	137	19	144	26	146	19	153	26
55	140	22	148	30	149	22	157	30
60	144	26	152	34	152	25	160	33
65	147	29	155	37	156	29	164	37
70	150	32	159	41	159	32	168	41
75	154	36	163	45	162	35	172	45
80	157	39	166	48	166	39	175	48
85	160	42	170	52	169	42	179	52
90	164	46	174	56	172	45	183	56
95	167	49	178	60	176	49	186	59
100	170	52	181	63	179	52	190	63

Factory Charge (B)
Standard Diameter

STEP 2. CHARGE BY LINESET LENGTH



CAUTION

ENSURE VALVES ARE OPEN AND ADDITIONAL CHARGE IS ADDED PER CHART BEFORE APPLYING POWER.

Charge additional refrigerant calculated by the equation & table in Step 1.

After the refrigerant charge has bled into the indoor unit, open the liquid service valve. The service valve cap is the secondary seal for the valves and must be properly tightened to prevent leaks. Make sure cap is clean and apply refrigerant oil to threads and sealing surface on inside of cap. Tighten cap finger-tight and then tighten additional 1/6 of a turn to properly seat the sealing surfaces.

Break vacuum by fully opening liquid and suction base valve.

NOTE: 1.5 - 3.0 ton have front seating valves. 3.5 - 5.0 ton have front / back seating valve. Refer detail function on page 17. It is not necessary to force the stem tightly against the rolled lip.

STEP 3. SYSTEM START-UP TEST

For a detailed procedure, please visit the Daikin *One+* website at <https://www.daikinone.com>

NOTICE

ON INITIAL POWER STARTUP, THE **OUTDOOR UNIT** WILL DISPLAY CODE **E11**, SIGNALING THAT INITIAL **SYSTEM** TEST MUST BE RUN. FOLLOW THE DAIKIN COMMUNICATING THERMOSTAT SETUP SCREEN TO ENTER APPLICATION-UNIQUE INFORMATION. SEE DAIKIN COMMUNICATING THERMOSTAT MANUAL FOR DETAILED INFORMATION.

A system test is now required to check the equipment settings and functionality. Once selected, it checks the equipment for approximately 10 - 15 minutes. System test may exceed 15 minutes if there is an error. Refer to the Troubleshooting section, if error code appears.

Before starting the SYSTEM TEST, turn off the electric heater or gas furnace.

NOTE: Ensure the thermostat is in OFF. Choose "OFF" before "CHARGE MODE".

ADDITIONAL CHARGE ADJUSTING PROCEDURE

STEP 4. MEASURE SUBCOOLING TO VERIFY PROPER CHARGE

SET THERMOSTAT TO CHARGE MODE

If required additional charging amount cannot be charged to the system without operation, then use this "CHARGE MODE".

When adjusting "Sub cooling", use this "CHARGE MODE".

CHARGE MODE allows for charging of the system. System operates for a duration of approximately two hours while the equipment runs at full capacity. After two hours, the CHARGE MODE ends and the system resumes normal thermostat operation.

Before starting the CHARGE MODE, turn off the electric heater and finish SYSTEM START-UP TEST.

NOTE: Charging equipment must use dedicated PVE oil gauges and hoses.

1. Purge gauge lines.
2. Connect service gauge manifold to liquid base valve service ports.
3. Convert the liquid pressure to temperature using a temperature/pressure chart.
4. Temporarily install a thermometer on the liquid line at the liquid line service valve. Ensure the thermometer makes adequate contact and is insulated for best possible readings.
5. Subtract the liquid line temperature from the converted liquid pressure to determine subcooling.
6. Before starting the subcooling adjustment, make sure the outdoor ambient temperature is in the range shown in charging table and the unit is operating at 100% capacity. When the unit is ready for charging, the seven segment display will show "cha" and current subcooling value alternately. When the outdoor ambient temperature is 65°F-105°F, the seven segment display will show current subcooling value.
7. If the system subcooling is not within the range as shown in the charging table, adjust subcooling according to the following procedure.
 - If subcooling is low, add charge to adjust the subcooling as specified in the following table.
 - If subcooling is high, remove charge to adjust the subcooling as specified in the following table.

NOTE: The seven segment display can keep flashing "cha" in charge mode when the system is not in condition. Then subcool adjustment is not available. Please complete charging following STEP1 and 2.

NOTE: To achieve rated performance, measure subcooling using a pressure gauge and temperature sensor.

SUBCOOLING = (SAT. LIQUID TEMP.) - (LIQUID LINE TEMP.)

Charging Table

OD Ambient Temp (degF)		< 65°F	65°F to 105°F			> 105°F
			DX6VSA	DX6VSS	DZ6VSA	
Subcooling (degF)	1.5 ton	Weigh in Charge	10 ± 1°F	10 ± 1°F	10 ± 1°F	Weigh in Charge
	2.0 ton		12 ± 1°F	12 ± 1°F	12 ± 1°F	
	2.5 ton		14 ± 1°F	14 ± 1°F	14 ± 1°F	
	3.0 ton		13 ± 1°F	15 ± 1°F	15 ± 1°F	
	3.5 ton		-	8 ± 1°F	8 ± 1°F	
	4.0 ton		-	9 ± 1°F	9 ± 1°F	
5.0 ton	-	9 ± 1°F	9 ± 1°F			

Note: Subcooling information is valid only while "cha" and current subcooling value is being displayed alternately on PCB.

NOTE: Not more than 8 oz. of refrigerant be added to the system to achieve the target subcooling. It is recommended adding 1 oz. refrigerant each time, then wait 10 minutes to stabilize the system.

NOTICE
CHECK THE SCHRADER PORTS FOR LEAKS AND TIGHTEN VALVE CORES, IF NECESSARY. INSTALL CAPS FINGER-TIGHT.

NOTICE
Do NOT ADJUST THE CHARGE BASED ON SUCTION PRESSURE.

SATURATED LIQUID PRESSURE TEMPERATURE CHART	
LIQUID PRESSURE PSIG	R-410A °F
200	70
205	72
210	73
215	75
220	76
225	77
230	79
235	80
240	81
245	83
250	84
255	85
260	87
265	88
270	89
275	90
280	91
285	92
290	94
295	95
300	96
305	97

SATURATED LIQUID PRESSURE TEMPERATURE CHART	
LIQUID PRESSURE PSIG	R-410A °F
310	98
320	100
330	102
340	105
350	107
360	109
370	111
380	113
390	115
400	117
410	118
420	120
430	122
440	124
450	126
460	127
470	129
480	131
490	133
500	134
510	136
520	137

SYSTEM OPERATION

SYSTEM ADVANCED FEATURES

This system permits access to additional system information, advanced set-up features, and advanced diagnostic/troubleshooting features.

These advanced features are organized into a menu structure.

For detailed functions and menu layout, please visit the Daikin One+ Smart Thermostat website at

<https://www.daikinone.com>

COOLING BOOST MODE

COOLING BOOST MODE enables the system to operate at increased compressor speeds in cooling mode to satisfy unusual high loads. COOLING BOOST MODE is initiated by an outdoor temperature sensor located in the outdoor unit. Please note that outdoor equipment operational sound levels may increase while the equipment is running in COOLING BOOST MODE since compressor speed higher than normal operation is allowed.

NOTE: COOLING BOOST MODE is ON by default and is activated when the outdoor temperature reaches 100°F. COOLING BOOST MODE can be disabled and enabled and the activation temperature adjusted in "COOLING BOOST MODE Temperature"

HEATING BOOST MODE (HP MODEL ONLY)

HEATING BOOST MODE enables the system to operate at increased compressor speed while in heating mode, regardless of outdoor ambient temperature. However, maximum compressor speeds only appear in low ambient temperature operation if HEATING BOOST MODE is disabled.

BACKUP DEFROST (DEFROST HEAT) MODE (HP MODEL ONLY)

This mode enables the system to select heating operation during defrost. When this mode is ON, 2nd heating source (Electric Heater or Gas Furnace) is turned on during defrost. This mode is initiated by an outdoor temperature sensor located in the outdoor unit. This mode is activated when the outdoor temperature reaches set point. Also "Always ON" and "OFF" are available.

MAXIMUM DEFROST INTERVAL

This setting enables the system to change timer defrost interval. In the case system needs to have defrost operation more frequently, defrost interval can be changed. The initial setting is 120 min.

DEHUMIDIFICATION

The thermostat reads the indoor humidity level from the field setting menu and allows the user to set a dehumidification target based on these settings. The thermostat controls the humidity level of the conditioned space using the cooling system. Dehumidification is engaged whenever a cooling demand is present and structural humidity levels are above the target level. When this condition exists the circulating fan output is reduced, increasing system run time, over cooling the evaporator coil and ultimately removing more humidity from the structure than if only in cooling mode.

For effective dehumidification operation:

- Please revise it to read ensure Dehumidification is NOT set to "OFF."
- If "STD", system run lower CFM than normal cooling mode.
- In addition, the system can have Enhanced Dehumidification operation in setting "A", "B" or "C" based on dehumidification demand.
In the Enhanced Dehumidification the indoor airflow is lower than Standard Dehumidification. Setting "A" allows for the widest compressor range with lower cfm than standard dehumidification. Setting "B" limits compressor operation range and keeps high dehumidification capacity. In setting "C" the system runs fixed at 100% compressor and airflow. See Figure 1.
- Verify the cooling airflow profile (cool profiles) is set to "Profile D".
- For additional dehumidification control, airflow settings are field adjustable and can be fine-tuned to a value that is comfortable for the application from a range of Cool Airflow Trim.

NOTE: In high humidity environments, sweating on supply ducts, cased coils or air handler cabinets can become an issue in Enhanced Dehumidification operation. It is recommended covering them with 2" fiberglass insulation for these installations.

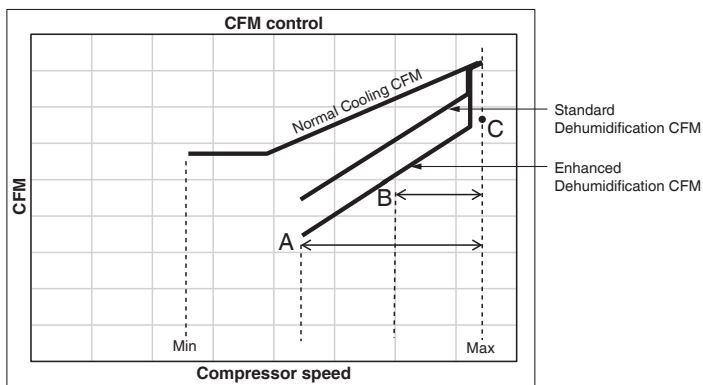

Figure 1

QUIET MODE

QUIET MODE enables the system to operate at decreased compressor and fan speeds to satisfy quiet driving.

QUIET MODE is initiated by user's setting ("ON" or "OFF". Default is "OFF").

NOTE:

"NOISE DOWN LEVEL" is initiated by user's setting.

("LEVEL" "1", "2" or "3." Default is "LEVEL" "2" "LEVEL" "3" is the most quiet.)

If during operation the capacity demand is high, then the quiet mode function will be temporary off by capacity priority function to return the room temperature to the set point. (Default capacity priority setting is ON)

Capacity priority setting = OFF

Capacity priority setting = ON

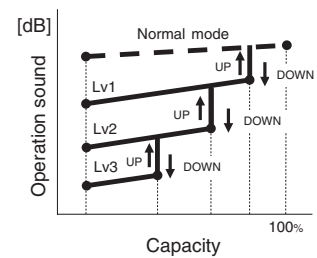
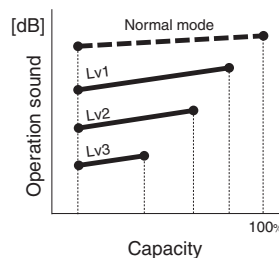

ZONING MODE

ZONING MODE is recommended to use when the zoning controller and dampers are installed. This mode allows the system to run with lower indoor air flow comparing with normal operation when the cool or heat demand is low. The ZONING MODE is disabled in factory default setting. It can be activated through the thermostat user menu and 7-segment display.

CIRCULATION SELECTION

This setting can be used to switch circulation factor ON and OFF to avoid automatically increasing the indoor CFM by circulation control.

When it is ON, the system may increase indoor CFM to circulate indoor air in the event the outdoor control detected low evaporative temperature.

When it is OFF, even if the outdoor control detects low evaporative temperature, it will NOT increase CFM.

ON is recommended generally, but when a zoning controller is connected, it is recommended to be OFF on this setting to avoid unexpected high static pressure.

SET THERMOSTAT TO ADJUST MAXIMUM COMPRESSOR SPEED

Maximum compressor speed at which the outdoor unit will operate can be changed using thermostat. Maximum compressor speed can be changed to get the required capacity or efficiency. Once the maximum speed is set, the system operates between the set maximum speed and default low speed.

SET THERMOSTAT TO ADJUST INDOOR AIR CFM TRIM

User can change the airflow trim at high, intermediate and low compressor speed.

Select:

Cool Airflow trim High: -15% ~ +15%

Cool Airflow trim Intermediate: -15% ~ Full*

Cool Airflow trim Low: -15% ~ Full*

Heat Airflow trim High: -15% ~ +15%

Heat Airflow trim Intermediate: -15% ~ +15%

Heat Airflow trim Low: -15% ~ +15%

Under each trim setting, the airflow can be increased or decreased by a certain percentage.

* The Inverter system uses lower compressor speed and lower indoor unit CFM to optimize system performance.

To obtain 100% CFM for home circulation, use full Trim setting instead of Int/Low speed.

This is recommended for applications with unusual cold return temperatures such as basements.

NOTE: Trim settings of the following combinations are restricted.

Outdoor Unit	DX6VS*361*A*/DZ6VS*361*A*	Trim more than 10% settings are invalid. Trimmed up CFM makes miss matching error.
Indoor Unit	D*96VC0403B/0603B D*97MC0603B D*80VC0603B/0803B MBVC1200 D*96SC0603BU	
Outdoor Unit	DX6VS*601*A*/DZ6VS*601*A*	Trim more than 5% settings are invalid. Trimmed up CFM makes miss matching error.
Indoor Unit	D*96VC0804C D*97MC0804C DM80VX0804C	

Depending on the connected indoor unit, there are restrictions on the positive side Trim setting.

If you want to change the Cool Airflow Trim to positive side, be sure to confirm the Airflow Trim restrictions in the latest indoor unit installation manual.

To see any restriction of added new combination, the latest manual can be obtained from the website "DAIKIN CITY (Installation Manual/Unitary Split System)" or "PartnerLink (InfoFinderPlus/Literature)".

[DAIKIN CITY URL]

<https://www.daikincity.com/Library/>

[DAIKIN URL]

<http://www.daikinac.com/>

[PartnerLink URL]

<https://partnerlinkmarketing.goodmanmfg.com/goodman/info-finder-plus>

SET THERMOSTAT TO ADJUST INDOOR AIRFLOW PROFILE

The System offers several custom ON/OFF ramping profiles for cooling. These profiles may be used to enhance cooling performance and increase comfort level.

- **Profile A** provides only an OFF delay of one (1) minute at 100% of the cooling demand airflow.

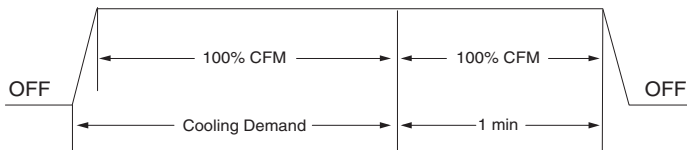

- **Profile B** ramps up to full cooling demand airflow by first stepping up to 50% of the full demand for 30 seconds. The motor then ramps to 100% of the required airflow. A one (1) minute OFF delay at 100% of the cooling airflow.

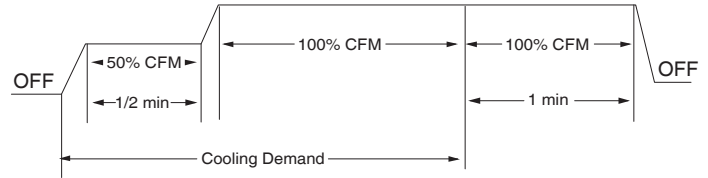

- **Profile C** ramps up to 82% of the full cooling demand airflow and operates there for approximately 7 1/2 minutes. The motor then steps up to the full demand airflow. Profile C also has a one (1) minute 100% OFF delay.

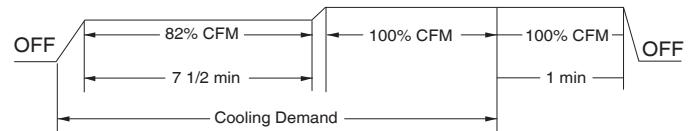

- **Profile D** (default) ramps up to 50% of the demand for 1/2 minute, then ramps to 82% of the full cooling demand airflow and operates there for approximately 7 1/2 minutes. The motor then steps up to the full demand airflow. Profile D has a 1/2 minute at 50% airflow OFF delay.

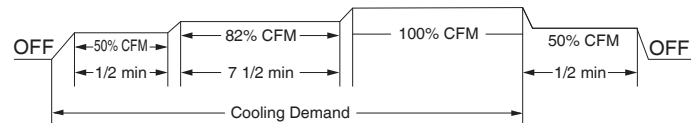

Airflow Tables

SET THERMOSTAT TO ADJUST COOL/HEAT AIRFLOW ON DELAY AND COOL/HEAT AIRFLOW OFF DELAY

Select "Cool/Heat Airflow ON Delay" or "Cool/Heat Airflow OFF Delay". Check the installation manual of the indoor unit for more details.

It change fan delay for set duration from normal operation.

SET THERMOSTAT TO CHECK SYSTEM STATUS

Status menu displays information about the systems current status.

This menu can be utilized to confirm correct functionality of the equipment and for troubleshooting purposes

HEAT PUMP WITH OUTDOOR TEMPERATURE LOCKOUTS

It is recommended to set the outdoor temperature lockouts during the initial thermostat set up. Heat pump lockout temp will enable the compressor to be turned off and switch heating source from refrigeration to auxiliary/secondary heating under low outdoor ambient conditions.

Aux heat lockout temp will enable auxiliary/secondary heating to be turned off when outdoor temperature is higher than the aux heat lockout temp.

DZ6VS*181 • 241 • 301 • 361*: 3D138076B



WARNING
HIGH VOLTAGE!
DISCONNECT ALL POWER BEFORE SERVICING OR INSTALLING THIS UNIT. MULTIPLE POWER SOURCES MAY BE PRESENT. FAILURE TO DO SO MAY CAUSE PROPERTY DAMAGE, PERSONAL INJURY OR DEATH.

WIRING DIAGRAM

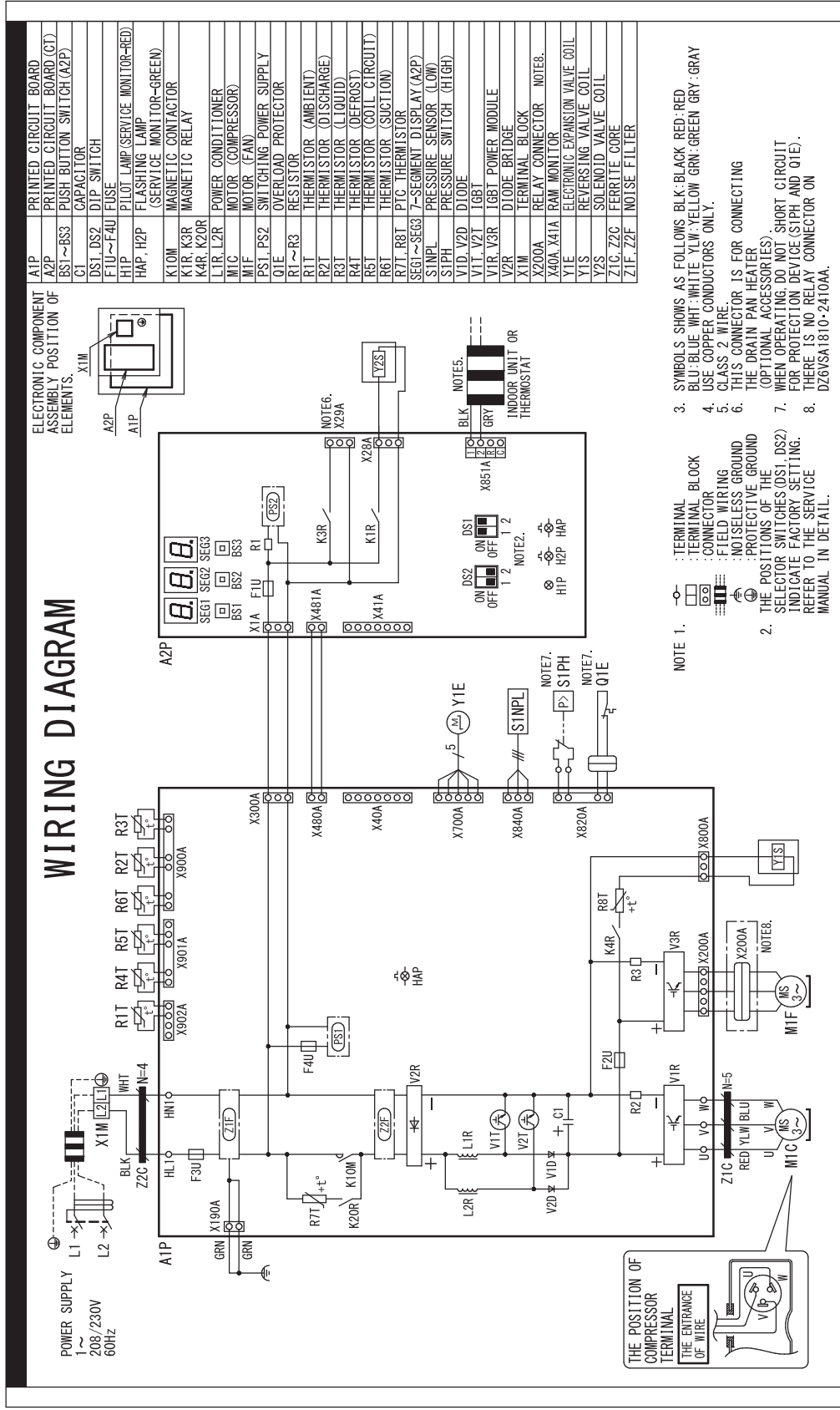

A1P	PRINTED CIRCUIT BOARD
A2P	PRINTED CIRCUIT BOARD (G1)
B51~B53	PUSH-BUTTON SWITCH (A2P)
C1	CAPACITOR
DS1, DS2	DTP SWITCH
F1U~F4U	FUSE
H1P	PILOT LAMP (SERVICE MONITOR-RED)
HAP, H2P	FLASHING LAMP (SERVICE MONITOR-GREEN)
K10M	MAGNETIC CONTACTOR
K1R, K3R	MAGNETIC RELAY
K4R, K20R	MOTOR (COMPRESSOR)
L1R, L2R	POWER CONDITIONER
M1C	MOTOR (FAN)
PS1, PS2	SWITCHING POWER SUPPLY
Q1E	OVERLOAD PROTECTOR
R1~R3	RESISTOR
R1T	THERMISTOR (AMBIENT)
R2T	THERMISTOR (DISCHARGE)
R3T	THERMISTOR (LIQUID)
R4T	THERMISTOR (DEFROST)
R5T	THERMISTOR (COIL CIRCUIT)
R6T	THERMISTOR (SUCTION)
R7T, R8T	PTC THERMISTOR
SEG1~SEG3	7-SEGMENT DISPLAY (A2P)
S1NPL	PRESSURE SENSOR (LOW)
S1PH	PRESSURE SWITCH (HIGH)
V1D, V2D	DIODE
V1T, V2T	IGBT
V1R, V3R	IGBT POWER MODULE
V2R	DIODE BRIDGE
X1M	TERMINAL BLOCK
X200A	RELAY CONNECTOR
X40A, X41A	RAM MONITOR
Y1E	ELECTRONIC EXPANSION VALVE COIL
Y1S	REVERSING VALVE COIL
Y2S	SOLENOID VALVE COIL
Z1C, Z2C	FERRITE CORE
Z1F, Z2F	NOISE FILTER

ELECTRONIC COMPONENT ASSEMBLY POSITION OF ELEMENTS.

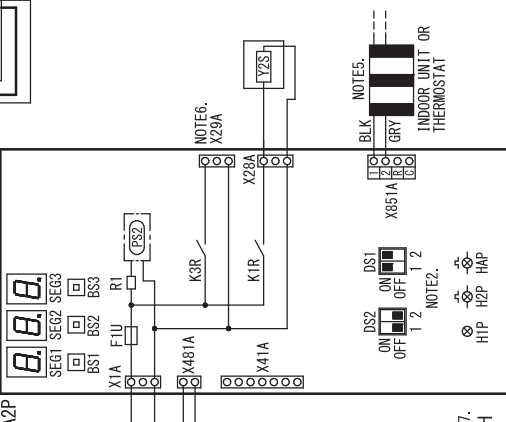
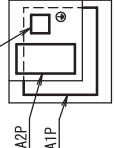

- NOTE 1.
- : TERMINAL
 - : TERMINAL BLOCK
 - : CONNECTOR
 - : FIELD WIRING
 - : NOISELESS GROUND
 - : PROTECTIVE GROUND
 - ⊕: THE POSITIONS OF THE SELECTOR SWITCHES (DS1, DS2) INDICATE FACTORY SETTING. REFER TO THE SERVICE MANUAL IN DETAIL.
- NOTE 2.
- ⊕: THE DRAIN PAN HEATER (OPTIONAL ACCESSORIES)
 - ⊕: WHEN OPERATING DO NOT SHORT CIRCUIT FOR PROTECTION DEVICE (S1PH AND Q1E).
 - ⊕: THERE IS NO RELAY CONNECTOR ON DZ6VSA1810-2410AA.
- NOTE 3.
- SYMBOLS SHOWS AS FOLLOWS: BLK:BLACK RED:RED BLU:BLUE WHT:WHITE YLM:YELLOW GRN:GREEN GR:GRAY USE COPPER CONDUCTORS ONLY.
 - CLASS 2 WIRE.
 - THIS CONNECTOR IS FOR CONNECTING
 - INDOOR UNIT OR THERMOSTAT

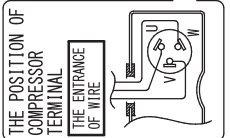

Wiring is subject to change. Always refer to the wiring diagram on the unit for the most up-to-date wiring.

WARNING

HIGH VOLTAGE!
DISCONNECT ALL POWER BEFORE SERVICING OR INSTALLING THIS UNIT. MULTIPLE POWER SOURCES MAY BE PRESENT. FAILURE TO DO SO MAY CAUSE PROPERTY DAMAGE, PERSONAL INJURY OR DEATH.

WIRING DIAGRAM

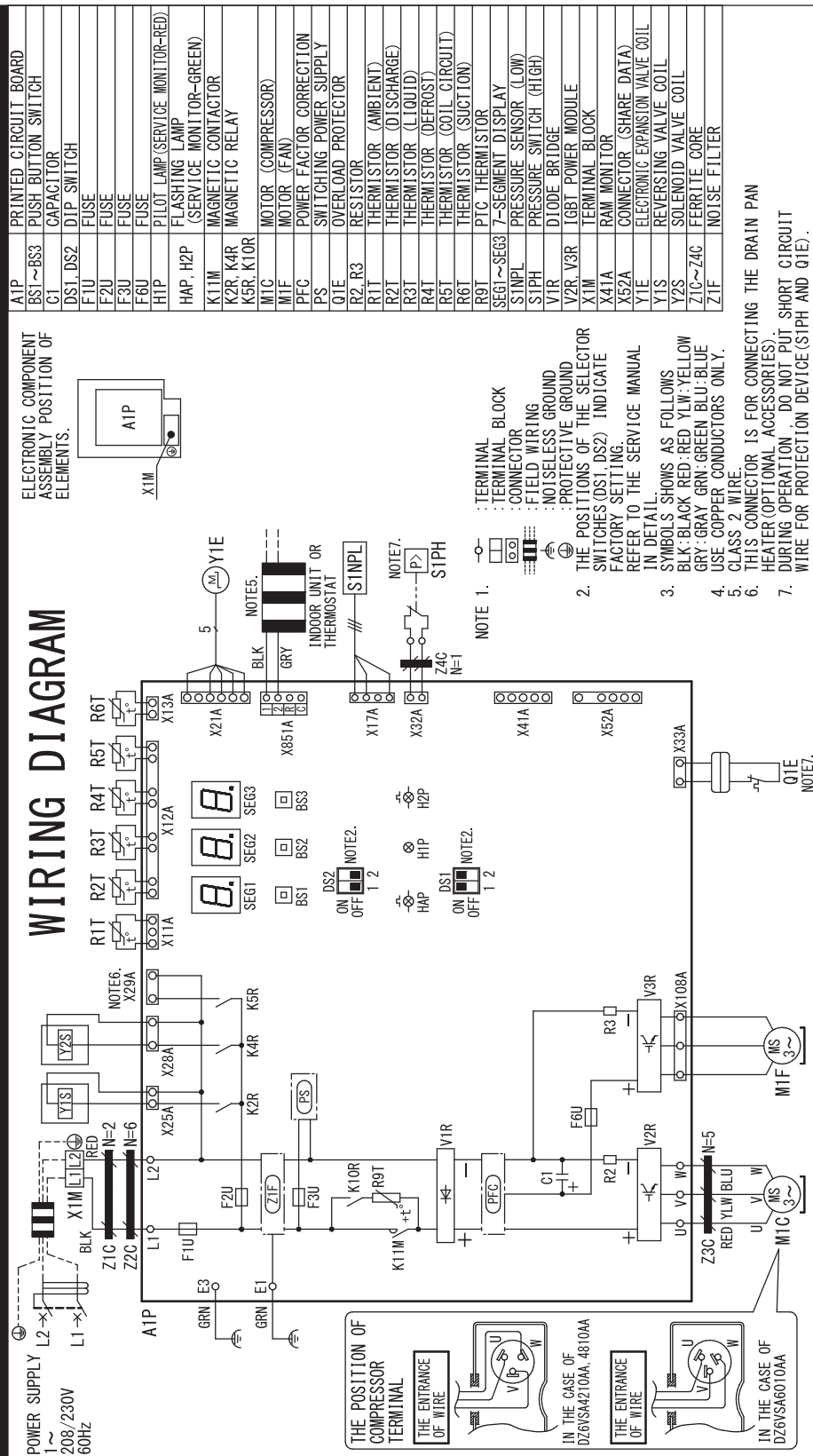

Wiring is subject to change. Always refer to the wiring diagram on the unit for the most up-to-date wiring.

WARNING

HIGH VOLTAGE!
DISCONNECT ALL POWER BEFORE SERVICING OR INSTALLING THIS UNIT. MULTIPLE POWER SOURCES MAY BE PRESENT. FAILURE TO DO SO MAY CAUSE PROPERTY DAMAGE, PERSONAL INJURY OR DEATH.

WIRING DIAGRAM

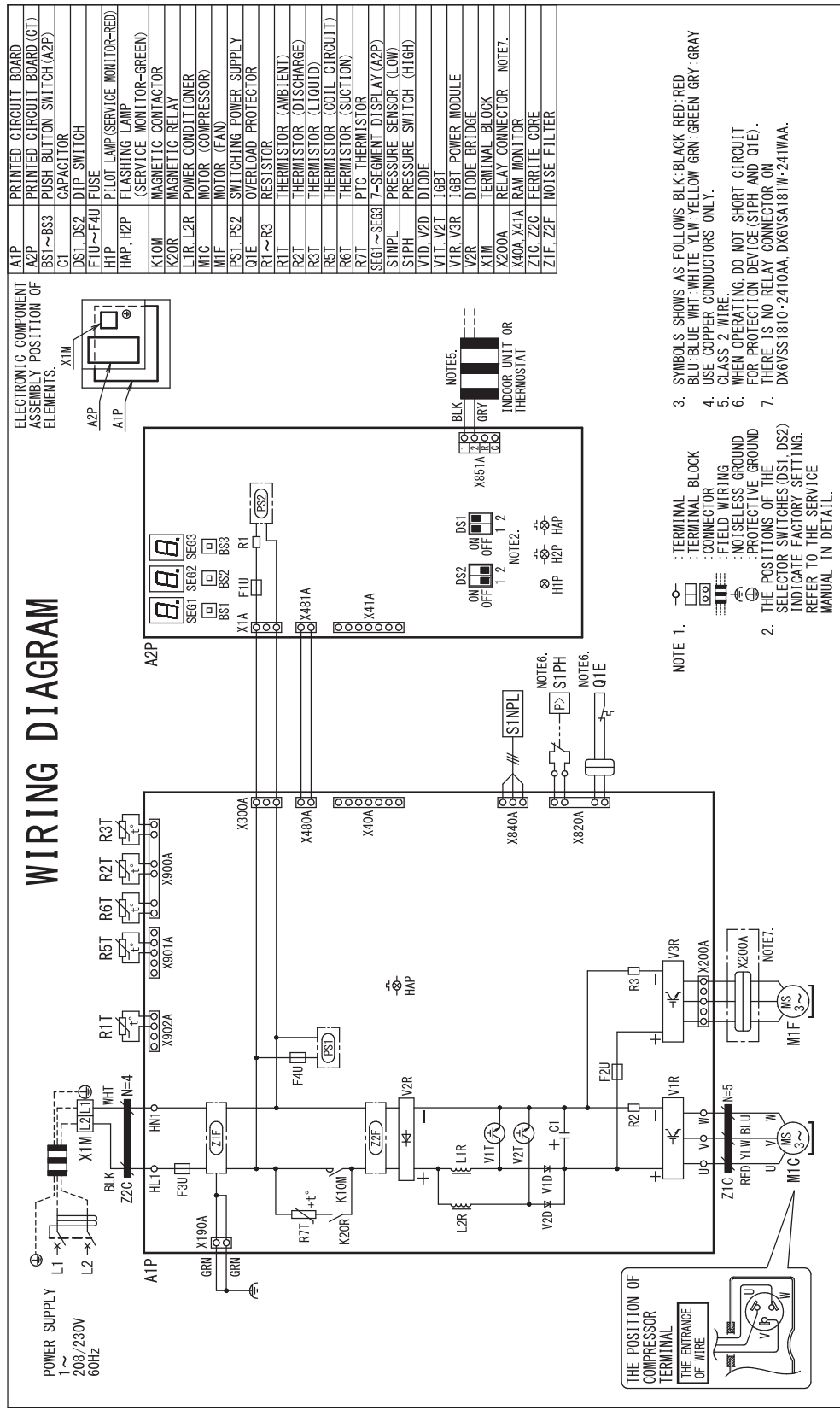

Wiring is subject to change. Always refer to the wiring diagram on the unit for the most up-to-date wiring.

WARNING
 HIGH VOLTAGE!
 DISCONNECT ALL POWER BEFORE SERVICING OR INSTALLING THIS UNIT. MULTIPLE POWER SOURCES MAY BE PRESENT. FAILURE TO DO SO MAY CAUSE PROPERTY DAMAGE, PERSONAL INJURY OR DEATH.

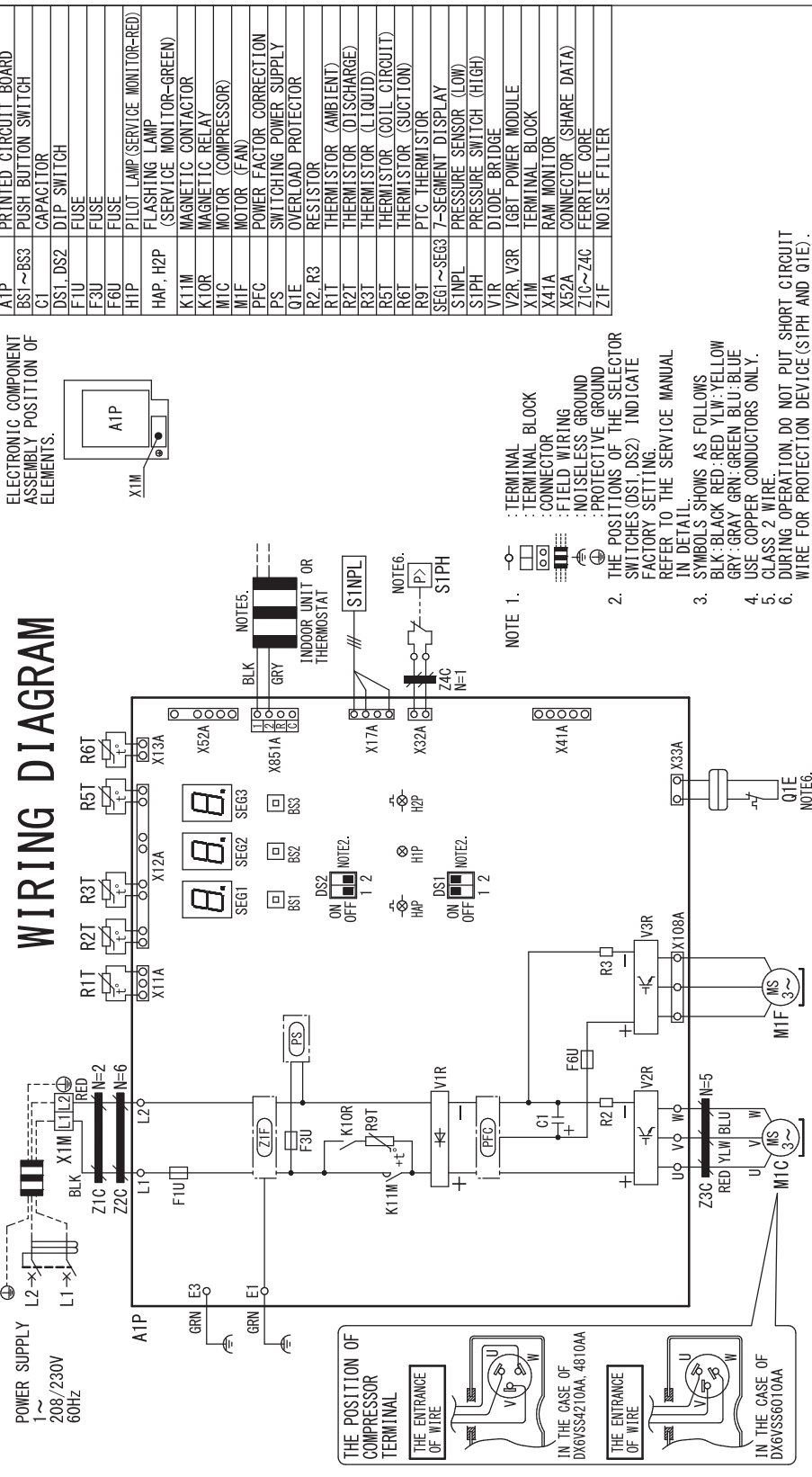

Wiring is subject to change. Always refer to the wiring diagram on the unit for the most up-to-date wiring.

TESTING CAPACITOR RESISTANCE



WARNING

AVOID CONTACT WITH THE CHARGED AREA.

• NEVER TOUCH THE CHARGED AREA BEFORE CONFIRMING THAT THE RESIDUAL VOLTAGE IS 50 VOLTS OR LESS.

1. SHUT DOWN THE POWER AND LEAVE THE CONTROL BOX FOR 10 MINUTES.
2. MAKE SURE TO TOUCH THE EARTH GROUND TERMINAL TO RELEASE THE STATIC ELECTRICITY FROM YOUR BODY (TO PREVENT FAILURE OF THE PC BOARD).
3. MEASURE THE RESIDUAL VOLTAGE IN THE SPECIFIED MEASUREMENT POSITION USING A VOM WHILE PAYING ATTENTION NOT TO TOUCH THE CHARGED AREA.
4. IMMEDIATELY AFTER MEASURING THE RESIDUAL VOLTAGE, DISCONNECT THE CONNECTORS OF THE OUTDOOR UNIT'S FAN MOTOR. (IF THE FAN BLADE ROTATES BY STRONG WIND BLOWING AGAINST IT, THE CAPACITOR WILL BE CHARGED, CAUSING THE DANGER OF ELECTRICAL SHOCK.)

English

<1.5 - 3.0 ton>

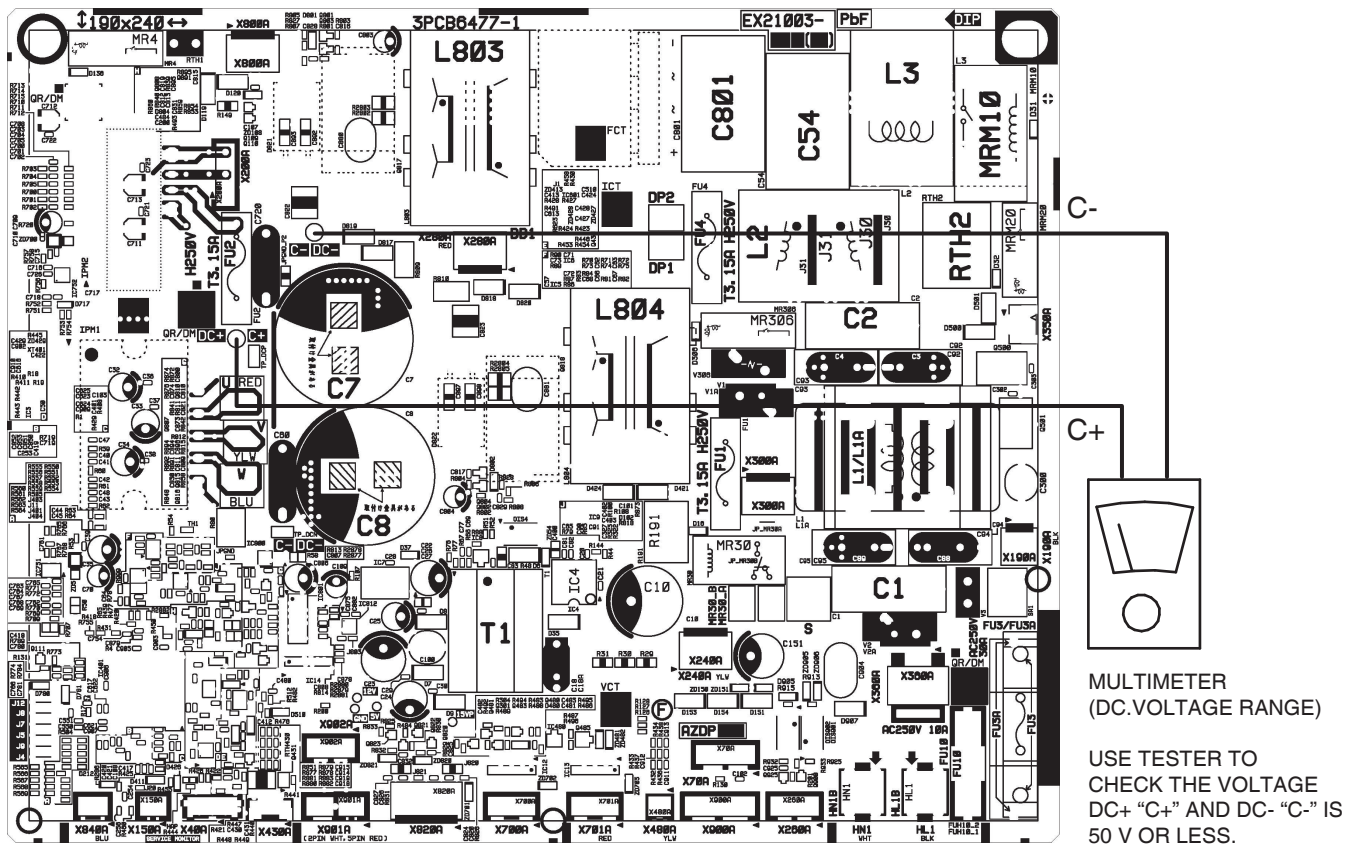

Capacitor Voltage

! WARNING

AVOID CONTACT WITH THE CHARGED AREA.

- NEVER TOUCH THE CHARGED AREA BEFORE CONFIRMING THAT THE RESIDUAL VOLTAGE IS 50 VOLTS OR LESS.
1. SHUT DOWN THE POWER AND LEAVE THE CONTROL BOX FOR 10 MINUTES.
 2. MAKE SURE TO TOUCH THE EARTH GROUND TERMINAL TO RELEASE THE STATIC ELECTRICITY FROM YOUR BODY (TO PREVENT FAILURE OF THE PC BOARD).
 3. MEASURE THE RESIDUAL VOLTAGE IN THE SPECIFIED MEASUREMENT POSITION USING A VOM WHILE PAYING ATTENTION NOT TO TOUCH THE CHARGED AREA.
 4. IMMEDIATELY AFTER MEASURING THE RESIDUAL VOLTAGE, DISCONNECT THE CONNECTORS OF THE OUTDOOR UNIT'S FAN MOTOR. (IF THE FAN BLADE ROTATES BY STRONG WIND BLOWING AGAINST IT, THE CAPACITOR WILL BE CHARGED, CAUSING THE DANGER OF ELECTRICAL SHOCK.)

<3.5 - 5.0 ton>

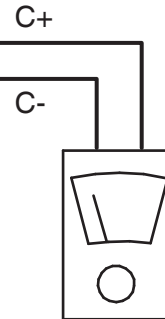
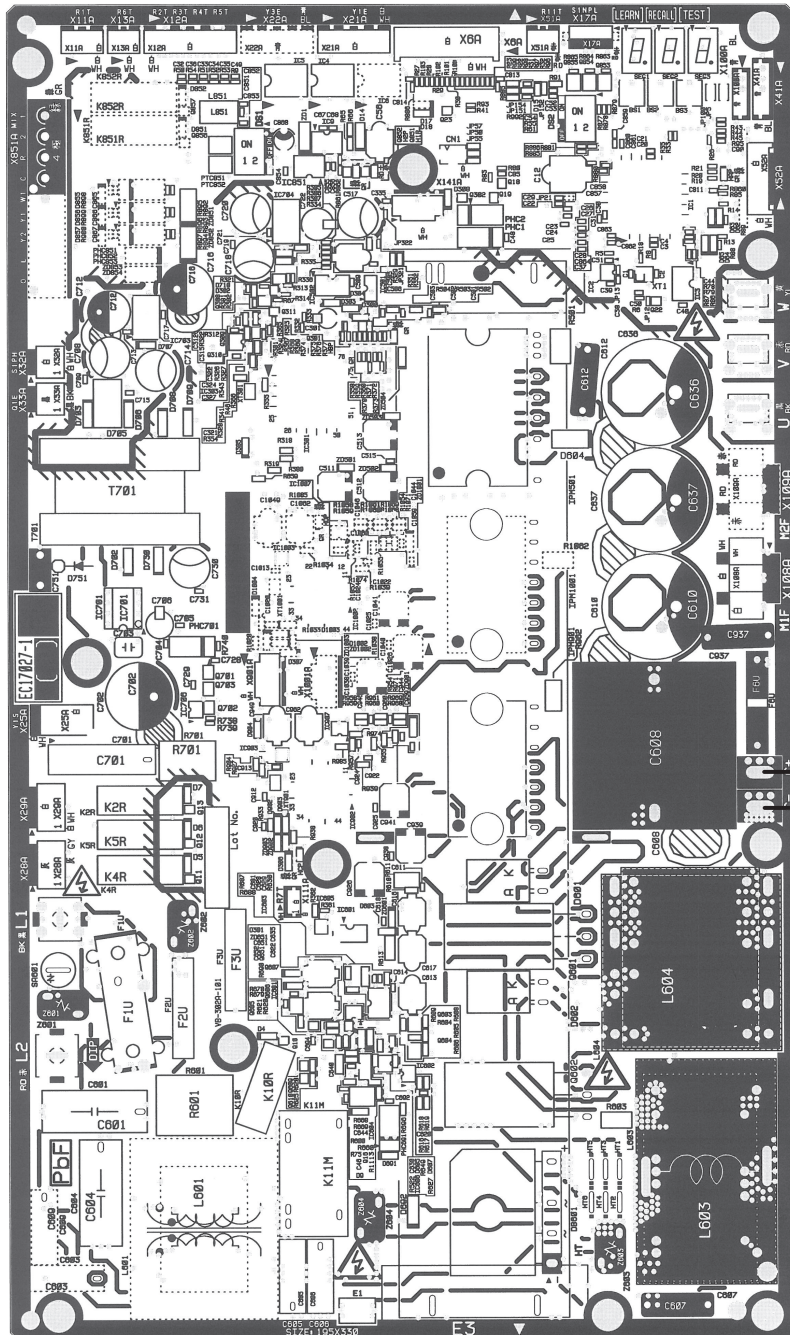

MULTIMETER
(DC.VOLTAGE RANGE)

USE TESTER TO
CHECK THE VOLTAGE
DC+ "C+" AND DC- "C-" IS
50 V OR LESS.

Capacitor Voltage

COOLING ANALYSIS CHART

POSSIBLE CAUSE X IN ANALYSIS GUIDE INDICATE "POSSIBLE CAUSE"	Comp discharge temp > 200F	Comp discharge temp < 105F	Comp discharge SH > 70F	Comp discharge SH < 20F	High pressure > 490PSIG	High pressure < 255PSIG	OD SSV SH > 20F	OD SSV SH < 4F	Low pressure > 185PSIG	Low pressure < 100PSIG	Repeated stop/start	Weak cooling	No switch cooling	Noise	Stop operation	Test Method Remedy
	Liquid stop valve does not fully open	X		X		X		X		X	X	X	X		X	
Gas stop valve does not fully open	X		X		X				X	X	X	X		X		Fully open gas stop valve
Line set restriction	X		X		X		X		X	X	X	X		X		Check line set
Line set length is too long	X		X		X		X		X	X	X	X		X		Check line set length; Change OD position if needed
Blocked filter-dryer	X		X		X		X		X	X	X	X		X		Replace filter-dryer
ID EEV coil failure	X	X	X	X	X	X	X	X	X	X	X	X		X	X	Check the connection to control board; Repair/replace if needed
ID EEV failure	X	X	X	X	X	X	X	X	X	X	X	X		X	X	Check ID EEV; Replace/repair if needed
High Pressure switch failure																Check resistance to verify operation; Replace if needed
Pressure sensor failure	X								X	X	X	X		X	X	Check resistance and connections to verify operation; Replace if needed
Suction temp sensor failure																Check resistance and connections to verify operation; Replace if needed
Discharge temp sensor failure	X	X	X	X							X	X		X	X	Check resistance and connections to verify operation; Replace if needed
Coil temp sensor failure			X	X	X	X					X	X		X	X	Check resistance and connections to verify operation; Replace if needed
Ambient temp sensor failure			X	X	X	X					X	X		X	X	Check resistance and connections to verify operation; Replace if needed
OD recirculation	X		X	X	X	X					X	X		X		Check resistance and connections to verify operation; Replace if needed
ID recirculation	X	X	X	X				X		X	X	X				Re-arrange OD position
Dirty OD heat-exchanger	X		X	X	X			X			X	X		X		Re-arrange ID position
Dirty ID heat-exchanger		X	X	X				X		X	X	X				Check OD heat-exchanger; Clean
Outdoor ambient temp is too high	X	X	X	X	X	X		X		X	X	X		X		Check ID heat-exchanger; Clean
Outdoor ambient temp is too low		X	X	X	X	X				X	X	X				-
ID return air temp is too high						X										-
ID return air temp is too low		X	X	X				X		X	X	X				-
Mixture of non-condensable gas	X		X	X	X	X	X	X	X	X	X	X		X		Recover refrigerant; evacuate pipe, and re-charge
OD fan motor failure	X		X	X	X	X					X	X		X	X	Replace OD fan motor
Over charge	X	X	X	X	X	X		X			X	X		X	X	Recover part of charge
Under charge	X	X	X	X	X	X				X	X	X		X	X	Test for leaks, Add refrigerant
Leak	X	X	X	X	X	X				X	X	X		X	X	Specify and repair the leak point
OD control board failure															X	Replace OD control board
ID failure	X	X	X	X	X	X	X	X	X	X	X	X	X		X	Replace ID
Compressor failure	X	X	X	X	X	X			X	X	X	X		X	X	Replace compressor
Compressor and gas furnace are operating at the same time																-
Cooling loop is not attached											X	X				Attach cooling loop to cold plate
Cooling loop grease is not enough											X	X				Add grease
Low ID CFM		X	X	X	X	X		X		X	X	X		X	X	Check airflow Trim, Check ID fan motor; Repair/replace if needed

Outdoor Normal Temperature Operating Range for Cooling Analysis: 67-115°F / Indoor Normal Temperature Operating Range: 65 - 85°F

HEATING ANALYSIS CHART

POSSIBLE CAUSE X IN ANALYSIS GUIDE INDICATE "POSSIBLE CAUSE"	TEST METHOD REMEDY															
	Comp discharge temp > 200F	Comp discharge temp < 105F	Comp discharge SH > 80F	Comp discharge SH < 20F	High pressure > 490PSIG	High pressure SSV < 270PSIG	High pressure LSV < 270PSIG	Low pressure < 40PSIG	Repeated stop/start	Weak heating	No switch heating	Noise	Incomplete defrost operation	Stop operation	Sweating liquid line	Test Method Remedy
Liquid stop valve does not fully open	X		X					X	X	X			X		X	Fully open liquid stop valve
Gas stop valve does not fully open	X		X					X	X	X			X		X	Fully open gas stop valve
Line set restriction	X		X						X	X			X		X	Check line set
Line set length is too long							X								X	Check line set length; Change OD position if needed
Blocked filter-dryer	X		X					X	X	X			X		X	Replace filter-dryer
OD EEV coil failure	X	X	X	X	X	X	X	X	X	X			X	X	X	Check OD EEV coil connection; Repair/replace if needed
OD EEV failure	X	X	X	X	X	X	X	X	X	X			X	X	X	Check OD EEV; Repair/replace if needed
ID EEV coil failure	X	X	X	X	X	X	X	X	X	X			X	X	X	Check the connection to control board; Repair/replace if needed
ID EEV failure	X	X	X	X	X	X	X	X	X	X			X	X	X	Check ID EEV; Replace/repair if needed
Check valve failure – Leakage		X							X	X					X	Check check valve; Repair/replace if needed
High Pressure switch failure			X												X	Check resistance to verify operation; Replace if needed
Pressure sensor failure			X	X	X	X	X	X	X	X					X	Check resistance and connections to verify operation; Replace if needed
Suction temp sensor failure	X	X	X	X	X	X	X	X	X	X					X	Check resistance and connections to verify operation; Replace if needed
Discharge temp sensor failure	X	X	X	X	X	X	X	X	X	X					X	Check resistance and connections to verify operation; Replace if needed
Coil temp sensor failure															X	Check resistance and connections to verify operation; Replace if needed
Defrost sensor failure															X	Check resistance and connections to verify operation; Replace if needed
Liquid temp sensor failure															X	Check resistance and connections to verify operation; Replace if needed
Ambient temp sensor failure															X	Check resistance and connections to verify operation; Replace if needed
OD recirculation	X		X		X	X	X	X	X	X						Re-arrange OD position
ID recirculation	X		X		X	X	X	X	X	X						Re-arrange ID position
Dirty OD heat-exchanger	X		X		X	X	X	X	X	X						Check OD heat-exchanger; Clean
Dirty ID heat-exchanger	X		X		X	X	X	X	X	X						Check ID heat-exchanger; Clean
Outdoor ambient temp is too high															X	-
Outdoor ambient temp is too low	X		X		X	X	X	X	X	X					X	-
ID return air temp is too high	X		X		X	X	X	X	X	X					X	-
ID return air temp is too low	X		X		X	X	X	X	X	X					X	-
Mixture of non-condensable gas	X		X		X	X	X	X	X	X					X	Recover refrigerant; evacuate pipe, and re-charge
OD fan motor failure	X		X		X	X	X	X	X	X					X	Replace OD fan motor
RV failure	X		X		X	X	X	X	X	X					X	Check RV; Repair/replace if needed
RV coil failure			X		X	X	X	X	X	X					X	Check RV coil; Repair/replace if needed
Over charge			X		X	X	X	X	X	X					X	Recover part of charge
Under charge	X	X	X	X	X	X	X	X	X	X					X	Test for leaks; Add refrigerant
Leak	X	X	X	X	X	X	X	X	X	X					X	Specify and repair the leak point
ID failure	X	X	X	X	X	X	X	X	X	X					X	Replace ID
OD control board failure			X		X	X	X	X	X	X					X	Replace OD control board
Compressor failure	X	X	X	X	X	X	X	X	X	X					X	Replace compressor
Cooling loop is not attached																Attach cooling loop to cold plate
Cooling loop grease is not enough																Add grease
Low ID CFM	X															Check airflow Trim, Check ID fan motor; Repair/replace if needed

Outdoor Normal Temperature Operating Range for Heating Analysis: 17 - 62°F / Indoor Normal Temperature Operating Range: 65 - 85°F

TROUBLESHOOTING

Thermostat display	Control board LED Display	Description	Probable Causes	Corrective Actions
12	E12	Indicates a general memory error.	<ul style="list-style-type: none"> High electrical noise Faulty control board 	<ul style="list-style-type: none"> Replace control board if necessary
13	E13	This error indicates the equipment is experiencing frequent high pressure faults. (CRITICAL)	<ul style="list-style-type: none"> Blocked/restricted outdoor unit coil and/or lines Stop valve not completely open Overcharge Outdoor fan not running High pressure switch (HPS) inoperable Faulty indoor and outdoor EEV coil Faulty indoor and outdoor EEV Faulty control board 	<ul style="list-style-type: none"> Check and clean outdoor unit coil and/or lines Check the opening of stop valve, should be full open; Repair/replace if needed Check refrigerant charge level; Adjust if needed Check outdoor fan motor & wiring; Repair/replace if needed Check indoor and outdoor EEV; Replace if needed Check indoor and outdoor EEV coil; Replace if needed Replace control board if necessary
14	-	This error indicates the equipment is experiencing frequent high pressure faults. Control has determined continued operation is acceptable. This indicates they may be a problem with the equipment. (MINOR)	<ul style="list-style-type: none"> Blocked/restricted outdoor unit coil and/or lines Stop valve not completely open Overcharge Outdoor fan not running High pressure switch (HPS) inoperable Faulty indoor and outdoor EEV coil Faulty indoor and outdoor EEV Faulty control board 	<ul style="list-style-type: none"> Check and clean outdoor unit coil and/or lines Check the opening of stop valve, should be full open; Repair/replace if needed Check refrigerant charge level; Adjust if needed Check outdoor fan motor & wiring; Repair/replace if needed Check indoor and outdoor EEV; Replace if needed Check indoor and outdoor EEV coil; Replace if needed Replace control board if necessary
15	E15	This error indicates the equipment is experiencing frequent low pressure faults. (CRITICAL)	<ul style="list-style-type: none"> Stop valve not completely open Restriction in refrigerant lines Low refrigerant charge Refrigerant leak Pressure sensor inoperable or not properly connected Indoor fan motor not functioning correctly Faulty indoor and outdoor EEV coil Faulty indoor and outdoor EEV Faulty control board 	<ul style="list-style-type: none"> Check the opening of stop valve, should be full open; Repair/replace if needed Check for restrictions in refrigerant line; Repair/replace if needed Check refrigerant charge level; Adjust if needed Test for system leaks using leak test procedure Check the connection to pressure sensor; Repair/replace if needed Check indoor and outdoor EEV; Replace if needed Check indoor and outdoor EEV coil; Replace if needed Check indoor blower motor & wiring; Repair/replace if needed Replace control board if necessary
16	-	This error indicates the equipment is experiencing frequent low pressure faults. Control has determined continued operation is acceptable. This indicates they may be a problem with the equipment. (MINOR)	<ul style="list-style-type: none"> Stop valve not completely open Restriction in refrigerant lines Low refrigerant charge Refrigerant leak Pressure sensor inoperable or not properly connected Indoor fan motor not functioning correctly Faulty indoor and outdoor EEV coil Faulty indoor and outdoor EEV Faulty control board 	<ul style="list-style-type: none"> Check the opening of stop valve, should be full open; Repair/replace if needed Check for restrictions in refrigerant line; Repair/replace if needed Check refrigerant charge level; Adjust if needed Test for system leaks using leak test procedure Check the connection to pressure sensor; Repair/replace if needed Check indoor and outdoor EEV; Replace if needed Check indoor and outdoor EEV coil; Replace if needed Check indoor blower motor & wiring; Repair/replace if needed Replace control board if necessary
17	E17	This error indicates the equipment is experiencing frequent compressor faults.	<ul style="list-style-type: none"> Stop valve not completely open The compressor wire is lost phase Compressor motor failure 	<ul style="list-style-type: none"> Check the opening of stop valve, should be full open; Repair/replace if needed Check the wire between control board and compressor Inspect compressor motor for proper function; Replace if necessary
18	E18	Indicates the control board may need to be replaced.	<ul style="list-style-type: none"> Outdoor fan motor not connected properly Faulty control board Electrical Noise 	<ul style="list-style-type: none"> Check wiring from Outdoor fan motor to control board; Repair if needed Replace control board if necessary
19	E19	This error indicates the equipment is experiencing frequent outdoor unit control board and/or motor faults.	<ul style="list-style-type: none"> Obstruction in fan rotation Outdoor fan motor not connected properly Outdoor fan not running Faulty control board Electrical Noise 	<ul style="list-style-type: none"> Check and clean grille of any debris Check wiring from Outdoor fan motor to control board; Repair if needed Check outdoor fan motor & wiring; Repair/replace if needed Replace control board if necessary
20	E20	This error indicates the equipment is experiencing outdoor EEV fault.	<ul style="list-style-type: none"> Outdoor EEV coil is not connected Faulty outdoor EEV coil Faulty control board 	<ul style="list-style-type: none"> Check outdoor EEV coil connection Repair/replace as needed Replace control board if necessary
21	E21	This error indicates the equipment is experiencing frequent low discharge superheat faults.	<ul style="list-style-type: none"> Thermistors inoperable or improperly connected Faulty indoor and outdoor EEV coil Faulty indoor and outdoor EEV Over charge Faulty pressure sensor Faulty control board 	<ul style="list-style-type: none"> Check the connection to thermistors; Repair/replace if needed Check indoor and outdoor EEV coil; Repair/replace if needed Check indoor and outdoor EEV; Replace/repair if needed Check refrigerant charge level; Adjust if needed Check pressure sensor; Repair/replace if needed Replace control board if necessary
22	E22	This error indicates the equipment is experiencing frequent high discharge temperature faults. Discharge thermistor is not put in correct position.	<ul style="list-style-type: none"> Discharge thermistor inoperable or improperly connected Discharge thermistor is put in incorrect position or off The compressor enclosure temperature is too high Low refrigerant charge Overcharge Faulty compressor 	<ul style="list-style-type: none"> Check discharge thermistor resistance and connections; Repair/replace as needed Check discharge thermistor position Check refrigerant charge level; Adjust if needed Check the compressor; Repair/replace if needed
23	E23	The control has detected that the Discharge Temperature Sensor is out of range.	<ul style="list-style-type: none"> Discharge thermistor inoperable or improperly connected 	<ul style="list-style-type: none"> Check discharge thermistor resistance and connections; Repair/replace as needed
24	E24	The high pressure switch is open.	<ul style="list-style-type: none"> High pressure switch (HPS) inoperable 	<ul style="list-style-type: none"> Check resistance on HPS to verify operation; Replace if needed

TROUBLESHOOTING

Thermostat display	Control board LED Display	Description	Probable Causes	Corrective Actions
25	E25	The outdoor air temperature sensor is open or shorted.	<ul style="list-style-type: none"> Faulty outdoor thermistor sensor or disconnect 	<ul style="list-style-type: none"> Inspect and test sensor; Replace sensor if needed
26	E26	The control determines that the pressure sensor is not reacting properly.	<ul style="list-style-type: none"> Pressure sensor inoperable or not properly connected 	<ul style="list-style-type: none"> Check the connection to pressure sensor; Repair/replace if needed
27	E27	The control has detected that the Outdoor Coil Defrost Temperature Sensor is out of range.	<ul style="list-style-type: none"> Outdoor defrost thermistor inoperable or not properly connected 	<ul style="list-style-type: none"> Check the connection to OD defrost thermistor; Repair/replace if needed
28	E28	The control has detected that the Outdoor Coil Temperature Sensor is out of range.	<ul style="list-style-type: none"> Outdoor coil thermistor inoperable or not properly connected 	<ul style="list-style-type: none"> Check the connection to OD coil thermistor; Repair/replace if needed
29	E29	The control has detected that the Liquid Temperature Sensor is out of range.	<ul style="list-style-type: none"> Liquid thermistor inoperable or not properly connected 	<ul style="list-style-type: none"> Check the connection to liquid thermistor; Repair/replace if needed
30	E30	Indicates the control board may need to be replaced.	<ul style="list-style-type: none"> Wiring to control board disconnected Faulty control board Electrical Noise 	<ul style="list-style-type: none"> Check wiring to control board; Repair as needed Replace control board if necessary
32	E32	This error indicates the equipment is experiencing high temperature faults on the outdoor unit control board.	<ul style="list-style-type: none"> Ambient air conditions too high Stop valve not completely open Cooling bracket screw(s) missing or not properly fastened <3.5 - 5.0 ton only> No or poor thermal grease coating between cooling plumbing and cooling bracket on control board <3.5 - 5.0 ton only> No flow or limited flow through control board cooling circuit (potential restriction in line or low refrigerant) <3.5 - 5.0 ton only> 	<ul style="list-style-type: none"> Cycle power; re-try during usable ambient temperature range Check grease applying condition <3.5 - 5.0 ton only> Check screw tightening condition <3.5 - 5.0 ton only> Check for restriction in line Check refrigerant charge level; Adjust if needed Check the opening of stop valve, should be full open; Repair/replace if needed
33	-	This error indicates the equipment is experiencing high temperature faults on the outdoor unit control board. Control has determined continued operation is acceptable. This indicates they may be a problem with the equipment.	<ul style="list-style-type: none"> Ambient air conditions too high Stop valve not completely open Cooling bracket screw(s) missing or not properly fastened <3.5 - 5.0 ton only> No or poor thermal grease coating between cooling plumbing and cooling bracket on control board <3.5 - 5.0 ton only> No flow or limited flow through control board cooling circuit (potential restriction in line or low refrigerant) <3.5 - 5.0 ton only> 	<ul style="list-style-type: none"> Cycle power; re-try during usable ambient temperature range Check grease applying condition <3.5 - 5.0 ton only> Check screw tightening condition <3.5 - 5.0 ton only> Check for restriction in line Check refrigerant charge level; Adjust if needed Check the opening of stop valve, should be full open; Repair/replace if needed
34	E34	Control board detected a high current condition. This indicates the potential for a short circuit.	<ul style="list-style-type: none"> Current spike in supply Stop valve not completely open The compressor wire is lost phase Faulty control board Faulty compressor 	<ul style="list-style-type: none"> Check power supply for in-rush current during start-up or steady state operation Check the opening of stop valve, should be full open; Repair/replace if needed Check the wire between control board and compressor Replace control board if necessary Check the compressor; Repair/replace if needed
35	E35	Control board detected a high current condition.	<ul style="list-style-type: none"> Short circuit condition Stop valve not completely open Overcharge Faulty control board Faulty compressor 	<ul style="list-style-type: none"> Check installation clearances. Check the opening of stop valve, should be full open; Repair/replace if needed Check refrigerant charge level; Adjust if needed Replace control board if necessary Check the compressor; Repair/replace if needed.
36	E36	The control encountered an abnormal condition during the startup procedure.	<ul style="list-style-type: none"> Blocked/restricted outdoor unit coil and/or lines The compressor wire is lost phase Inconsistent compressor load Faulty control board 	<ul style="list-style-type: none"> Check and clean outdoor unit coil and/or lines Check the wire between control board and compressor Replace control board if necessary
37	E37	Indicates the control board may need to be replaced.	<ul style="list-style-type: none"> Outdoor fan motor not connected properly Faulty control board 	<ul style="list-style-type: none"> Check wiring from Outdoor fan motor to control board; Repair if needed Replace control board if necessary
38	E38	The control has detected a voltage related issue with the compressor.	<ul style="list-style-type: none"> High or low voltage from supply The compressor wire is lost phase Faulty control board 	<ul style="list-style-type: none"> Correct low/high line voltage condition; Contact local utility if needed Check the wire between control board and compressor Replace control board if necessary
39	E39	Indicates the control board may need to be replaced.	<ul style="list-style-type: none"> Thermistors inoperable or improperly connected Faulty control board 	<ul style="list-style-type: none"> Check the connection to thermistors; Repair/replace if needed Replace control board if necessary
40	E40	Control determines that its compressor requirement is different than the compressor capability.	<ul style="list-style-type: none"> Memory card not correct Control board mismatch 	<ul style="list-style-type: none"> Check memory card data vs. outdoor unit model Verify control board size vs. outdoor unit model; Replace control board if necessary
41	E41	The control has detected a low refrigerant condition.	<ul style="list-style-type: none"> Refrigerant leak Low refrigerant charge Thermistors inoperable or not properly connected 	<ul style="list-style-type: none"> Test for system leaks using leak test procedure Check refrigerant charge level; Adjust if needed Check the connection to thermistor; Repair/replace if needed
42	E42	Control detects a low power supply voltage condition.	<ul style="list-style-type: none"> Low line voltage supply 	<ul style="list-style-type: none"> Check circuit breakers and fuses; Replace if needed Verify unit is connected to power supply as specified on rating plate Correct low line voltage condition; Contact local utility if needed

TROUBLESHOOTING

Thermostat Display	Control board LED Display	Description	Probable Causes	Corrective Actions
43	E43	Control detects a high power supply voltage condition.	<ul style="list-style-type: none"> High line voltage supply 	<ul style="list-style-type: none"> Verify unit is connected to power supply as specified on rating plate Correct high line voltage condition; Contact local utility if needed
44	E44	The control detects the outdoor temperature outside recommended operational range. Unit may continue to operate normally.	<ul style="list-style-type: none"> Ambient air conditions too high or low 	<ul style="list-style-type: none"> Cycle power; re-try during usable ambient temperature range
47	E47	The control is unable to start the System Verification test because indoor heat has been turned on by thermostat. Please set thermostat to off position.	<ul style="list-style-type: none"> Heat provided by secondary heating source 	<ul style="list-style-type: none"> Turn off Furnace or heater using thermostat before operation
49	E49	The control is unable to enter Charging Mode because indoor heat has been turned on by thermostat. Please set thermostat to off position.	<ul style="list-style-type: none"> Heat provided by secondary heating source 	<ul style="list-style-type: none"> Turn off heater using thermostat before operation
50	E50	This indicates there is a voltage issue on the control board. See service manual for troubleshooting information.	<ul style="list-style-type: none"> High or low voltage from supply voltage or frequency Faulty control board Noise 	<ul style="list-style-type: none"> Correct low/high line voltage condition; Contact local utility if needed Replace control board if necessary Contact local utility if needed
51*1	E51	This indicates potential communication issues have been detected by the outdoor unit control board.	<ul style="list-style-type: none"> Communication wiring disconnected 	<ul style="list-style-type: none"> Check communication wiring; Repair as needed
52	-	This error indicates the equipment is experiencing frequent compressor faults. Control has determined continued operation is acceptable. This indicates they may be a problem with the equipment.	<ul style="list-style-type: none"> Stop valve not completely open The compressor wire is lost phase Compressor motor failure 	<ul style="list-style-type: none"> Check the opening of stop valve, should be full open; Repair/replace if needed Check the wire between control board and compressor Inspect compressor motor for proper function; Replace if necessary
53	-	This error indicates the equipment is experiencing frequent outdoor unit control board and/or motor faults. Control has determined continued operation is acceptable. This indicates they may be a problem with the equipment.	<ul style="list-style-type: none"> Obstruction in fan rotation Outdoor fan motor not connected properly Outdoor fan not running Faulty control board Noise 	<ul style="list-style-type: none"> Check and clean grille of any debris Check wiring from Outdoor fan motor to control board; Repair if needed Check outdoor fan motor & wiring; Repair/replace if needed Replace control board if necessary
54	-	This error indicates the equipment is experiencing frequent low discharge superheat faults. Control has determined continued operation is acceptable. This indicates they may be a problem with the equipment.	<ul style="list-style-type: none"> Thermistors inoperable or improperly connected Faulty indoor EEV or indoor EEV coil (when cooling) Faulty control board Faulty outdoor EEV or outdoor EEV coil (when heating) 	<ul style="list-style-type: none"> Check the connection to thermistors; Repair/replace if needed Check indoor EEV; Replace if needed Check indoor EEV coil; Replace if needed Replace control board if necessary Check outdoor EEV; Replace if needed Check outdoor EEV coil; Replace if needed
55	-	This error indicates the equipment is experiencing frequent high discharge temperature faults. Control has determined continued operation is acceptable. This indicates they may be a problem with the equipment.	<ul style="list-style-type: none"> Discharge thermistor inoperable or improperly connected Discharge thermistor is put in incorrect position or off Low refrigerant charge Overcharge Faulty compressor 	<ul style="list-style-type: none"> Check discharge thermistor resistance and connections; Repair/replace as needed Check discharge thermistor position Check refrigerant charge level; Adjust if needed Check the compressor; Repair/replace if needed
56	E56	The control has detected if the Outdoor Suction Temperature Sensor is out of range.	<ul style="list-style-type: none"> Suction thermistor inoperable or not properly connected Faulty reversing valve 	<ul style="list-style-type: none"> Check the connection to suction thermistor; Repair/replace if needed Check reversing valve; Replace if needed
57	-	This indicates the control is sensing sweating on the cooling loop. <3.5 - 5.0 ton only>	<ul style="list-style-type: none"> Refrigerant Leak Low refrigerant charge Faulty indoor EEV or indoor EEV coil Thermistors inoperable or improperly connection 	<ul style="list-style-type: none"> Test for system leaks using leak test procedure Check refrigerant charge level; Adjust if needed Check indoor EEV; Replace if needed Check indoor EEV coil; Replace if needed Check the connection to thermistors; Repair/replace if needed

(*1) Network communication error (Refer to "NETWORK TROUBLESHOOTING")

TROUBLESHOOTING

Thermostat Display	Control board LED Display	Description	Probable Causes	Corrective Actions
58	E58	The Overload Protection sensor for Compressor is opened.	<ul style="list-style-type: none"> Overload protection (OL) sensor inoperable Jumper wire (X33A) is put in incorrect position or off 	<ul style="list-style-type: none"> Check resistance on OL sensor to verify operation; Replace if needed. Check OL sensor position on compressor body. Check jumper wire position (X33A)
B0	Eb0	The estimated airflow from indoor subsystem is near to 0 CFM.	<ul style="list-style-type: none"> Failed indoor blower motor Indoor fan motor not properly connected Too much static pressure 	<ul style="list-style-type: none"> Check ID fan motor wiring and connectors; Repair/replace if needed Check ID fan motor; Replace if needed Check the obstruction inside duct work.
B9	Eb9	Estimated airflow from motor is lower than the airflow requirement.	<ul style="list-style-type: none"> Failed indoor blower motor Indoor fan motor not properly connected Too much static pressure 	<ul style="list-style-type: none"> Check ID fan motor wiring and connectors; Repair/replace if needed Check ID fan motor; Replace if needed
D0	Ed0	Control board does not have the necessary data for it to properly perform its functions.	<ul style="list-style-type: none"> Outdoor unit is wired as part of a communicating system and integrated control module does not contain any shared data. 	<ul style="list-style-type: none"> Replace control board if necessary
D1	Ed1	Control board does not have the appropriate data needed to properly perform its functions.	<ul style="list-style-type: none"> Outdoor unit is wired as part of a communicating system and integrated control module contains invalid shared data or network data is invalid for the integrated control module. 	<ul style="list-style-type: none"> Replace control board if necessary
D2	Ed2	The airflow requirement is greater than the airflow capability of the indoor subsystem.	<ul style="list-style-type: none"> Outdoor unit is wired as part of a communicating system and outdoor unit requires airflow greater than indoor unit's airflow capability, or a type of indoor unit without EEV is connected to the system. Shared data is incompatible the system or missing parameters Communication wiring with indoor unit has loose connection. Airflow trim setting is out of range. See "SET THERMOSTAT TO ADJUST INDOOR AIR CFM TRIM" section. 	<ul style="list-style-type: none"> Check combination to be matched with rating list; correct if needed. Verify shared data is correct for your specific model; Repopulate data if required Check communication wiring and power supply wiring of indoor unit. Repair as needed. Verify trim setting and adjust if needed.
D3	Ed3	There is a mismatch between the shared data and the control physical hardware.	<ul style="list-style-type: none"> Shared data sent to integrated control module does not match hardware configuration. 	<ul style="list-style-type: none"> Verify shared data is correct for your specific model; Repopulate data if required
D4	Ed4	The memory card data has been rejected.	<ul style="list-style-type: none"> Shared data on memory card has been rejected. 	<ul style="list-style-type: none"> Verify shared data is correct for your specific model; Repopulate data if required

Items below are messages only displayed on the thermostat screen.

11	E11	This test is required at startup. Installer should navigate to the thermostat menu to run SYSTEM START-UP TEST. This code will clear once testing is complete.	<ul style="list-style-type: none"> Incomplete SYSTEM START-UP TEST SYSTEM START-UP TEST is running 	Run the SYSTEM START-UP TEST. (See the installation manual of the outdoor unit, "STEP3. SYSTEM START-UP TEST")
----	-----	--	--	--

TROUBLESHOOTING

NETWORK TROUBLESHOOTING

If a network communication error code has occurred, use the following steps to help troubleshoot the system. (For network communication error codes, refer to the table below and the tables of error codes for outdoor unit and indoor unit.)

After any wiring changes have been made or DS1 dip switches on the outdoor unit control board have been changed, apply power to the system and see if the error codes have cleared.

1. Confirm low voltage wiring is correct per installation instructions. Check for miswiring. (i.e. Terminal 1 and 2 is reversed.)

NOTE: A removable plug connector is provided with the control to make thermostat wire connections (3.5 - 5.0 ton only). This plug may be removed, wire connections made to the plug, and replaced. It is strongly recommended that you do not connect more than two wires into a single terminal in the field because there is a risk of the wires becoming loose, which may result in intermittent operation.

2. Check wires for damage. (i.e. Broken wire at terminal, broken inside wire nuts or damaged cable between units.)
3. Perform continuity check on wires to make sure cable is OK. Replace the cable if necessary
4. Change both dip switches of DS1 on the outdoor unit control board to the opposite position. See image below.

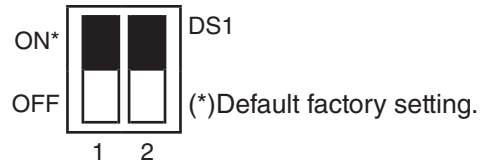

The integrated control module has some onboard tools that can be used to troubleshoot the network. These tools are: red communications LED, green receive (Rx) LED, and the learn button.

- Red communications LED – Indicates the status of the network. The table below indicates the LED status and the corresponding potential problem.
- Green receive LED – Indicates network traffic. The table below indicates the LED status and the corresponding potential problem.
- LEARN button – Used to reset the network. Press the button for approximately 5 seconds to reset the network.

LED COLOR	LED Status	Indication	Probable Causes	Corrective Actions
Red Communications LED Outdoor unit control board:(H1P) Indoor unit control board :(H2P)	Off	Normal condition	• None	• None
	1 Flash	Communications failure	• Unknown packet is received • Communications failure	• Depress learn button • Verify wiring connection
	2 Flash	Out-of-box reset	• Control power up • Learn button depressed	• None
Green Receive LED Outdoor unit control board:(H2P) Indoor unit control board:(H3P)	Off	No power Communications error	• No power to unit • Open fuse • Communication error	• Check circuit breakers and fuses; Reset/Replace if needed • Reset network by depressing learn button • Check communication wires (terminal 1/terminal 2 wires); Replace if needed • Check for shorts in low voltage wiring.
	1 Steady Flash	No network found	• Broken/disconnected communication wire(s) • Unit is installed as a legacy/traditional system	• Check communication wires (terminal 1/terminal 2 wires); Replace if needed • Check installation type (legacy/traditional or communicating)
	Rapid Flashing	Normal network traffic	• Control is "talking" on network as expected	• None
	On Solid	Terminal 1/Terminal 2 miss-wire	• Terminal 1 and Terminal 2 wires reversed at indoor unit, thermostat, or outdoor unit • Short between terminal 1 and terminal 2 wires • Short between terminal 1 or terminal 2 two wires and terminal C (24VAC) or terminal R (24VAC, COM)	• Check communication wires (terminal 1/terminal 2 wires); Replace if needed

SETTING THE MODE DISPLAY

MODE DISPLAY INTRODUCTION

A 3-digit display is provided on the printed circuit board (PCB) as a backup tool to the thermostat for reading faults, fault history, monitoring and setting up the outdoor unit. Follow the information provided in this section to learn how to use the mode display.

DISPLAY

The display consists of 3 digits.

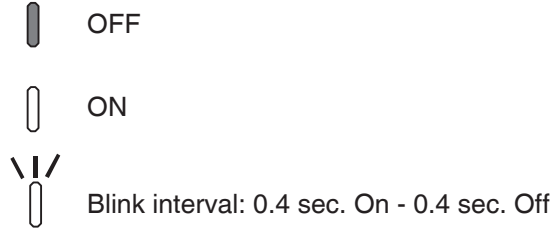
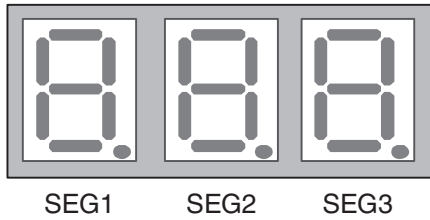

DISPLAY BUTTON LAYOUT

The display buttons shown can be used to navigate and select items:

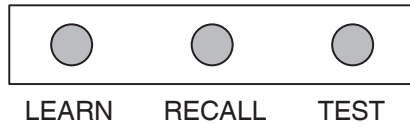

MODES

There are 5 modes which can be accessed using the setting display: "FAULT CODE, FAULT HISTORY, MONITORING, SETTING MODE 1" and "SETTING MODE 2".

To enter any of these modes, use the schemes shown in this section. Each mode has its own corresponding "Screen #" within the display itself which allows the user to navigate and use the features. (Example: The Fault Code is accessed and displayed from "Screen Zero" of the 7-segment display. The Fault History is accessed and displayed using "Screen One" of the display, etc.)

MODE	FUNCTION	DISPLAY SCREEN #
<i>Fault Code Display</i>	Present fault (if any).	0 (Default)
<i>Fault Code History</i>	6 Recent faults stored.	1
<i>Monitoring Mode</i>	*Monitors system values.	2
<i>Setting Mode 1</i>	*Can change system settings	3
<i>Setting Mode 2</i>	*Can change system settings.	4

**See tables at the end of this section.*

NAVIGATING THROUGH THE DISPLAY SCREENS

- SCREEN 0** The home or default screen on the display. This shows the most recent fault.
- SCREEN 1** To access, hold the "RECALL" button from screen 0 - 5 seconds.
- SCREEN 2** To access, hold the "RECALL" button from screen 1 - 5 seconds.
- SCREEN 3** To access, hold the "RECALL" button from screen 2 - 5 seconds.
- SCREEN 4** To access, hold the "RECALL" and "TEST" buttons simultaneously - 5 seconds.

To return to SCREEN 0 of the display, press the LEARN button.

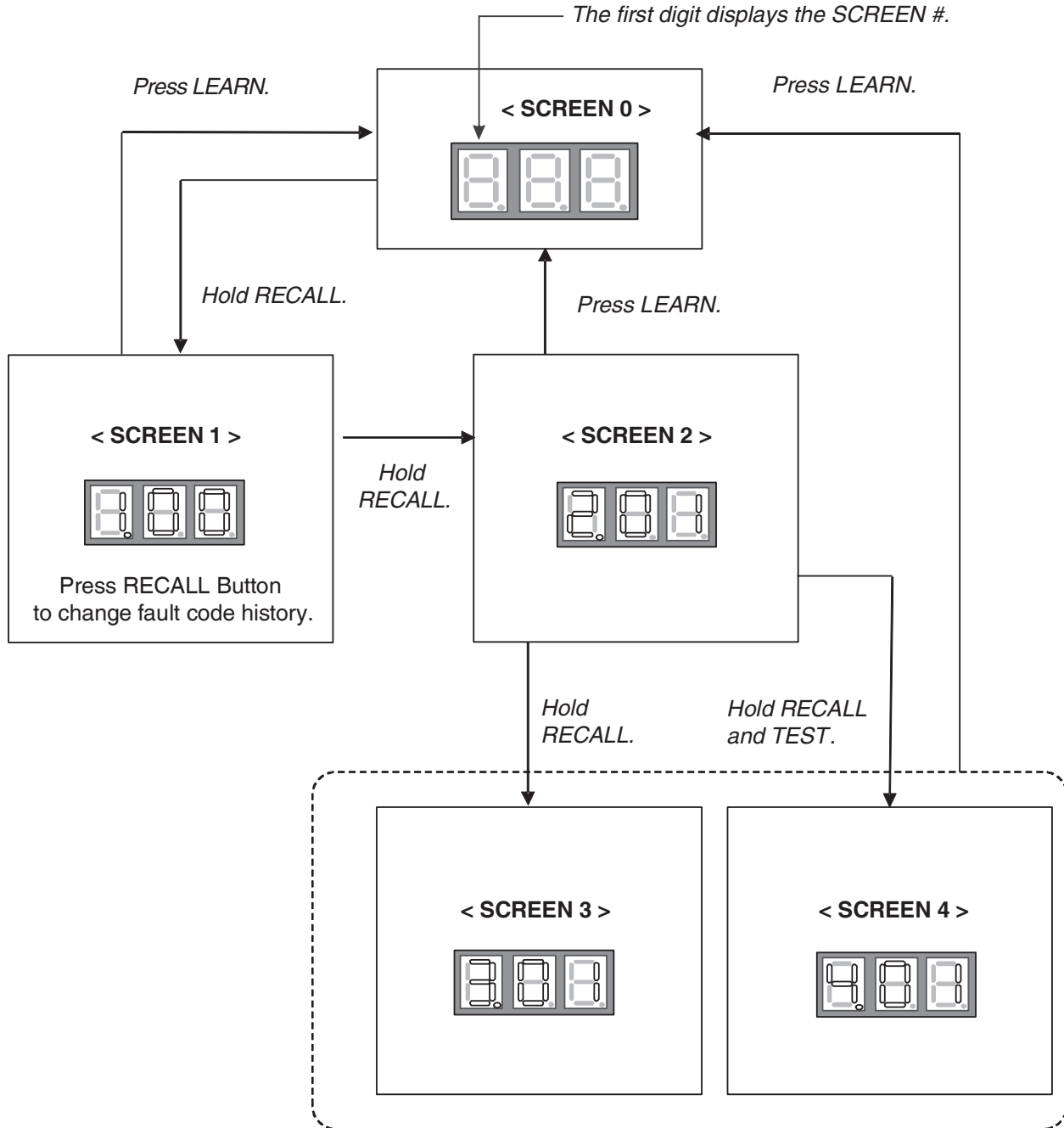

FAULT CODE HISTORY NAVIGATION

< SCREEN 1 >

This mode will allow the user to see the six most recent system faults.
For a list of the fault codes, please see the TROUBLESHOOTING tables in this document.

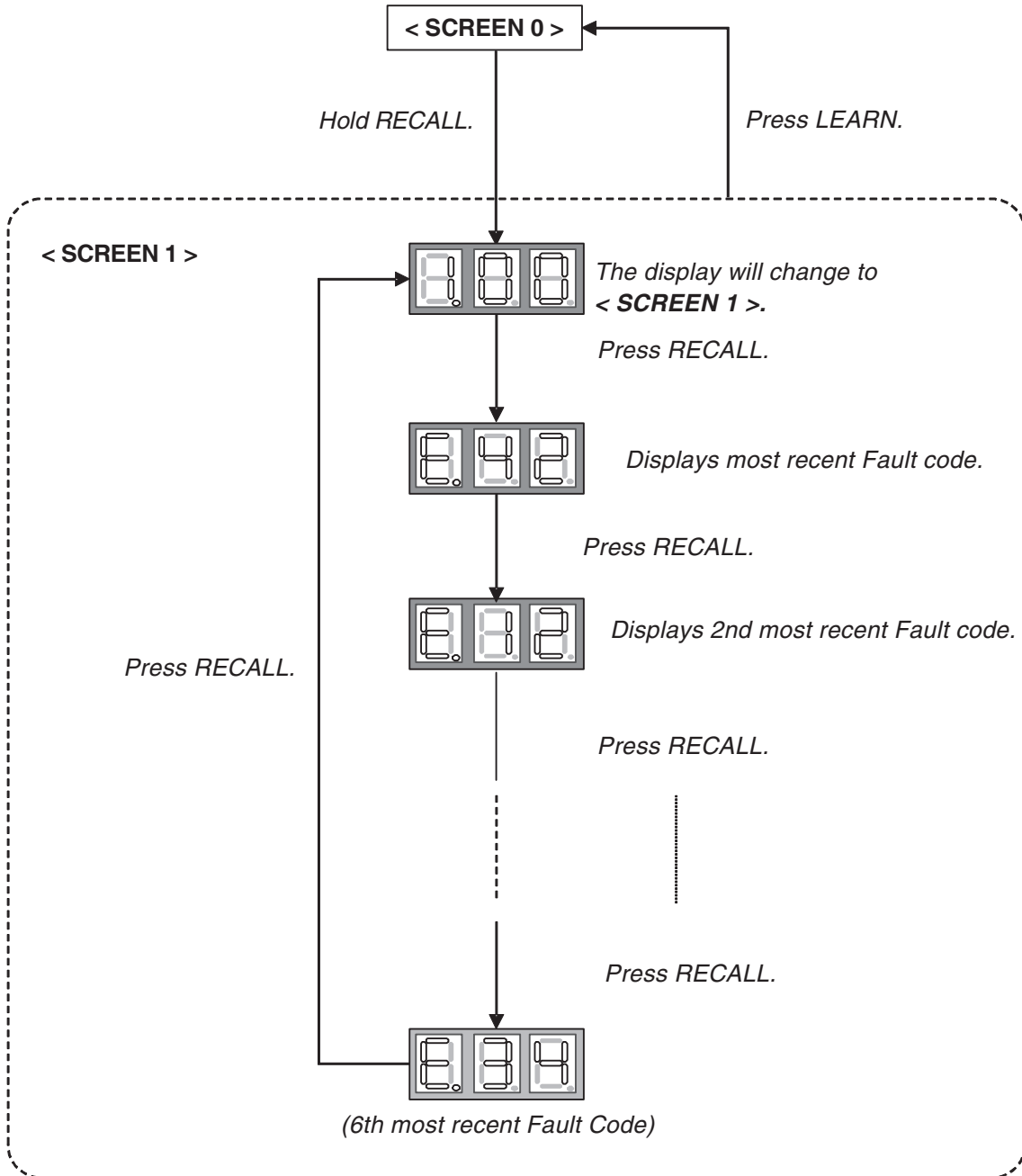



SETTING THE MODE DISPLAY

MONITORING MODE NAVIGATION

< SCREEN 2 >

This screen allows the user to monitor system variables as shown in the tables at the end of this section.

< SCREEN 0 >

-  OFF
-  ON
-  Blink interval:
0.4 sec. On - 0.4 sec. Off

< SCREEN 1 >

Hold *RECALL*.

Press *LEARN*.

< SCREEN 2 >

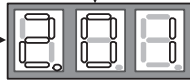

Press *RECALL*
to increase the value.

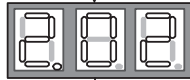

Press *RECALL*.



Press *RECALL*.

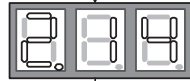

Press *TEST*
to confirm the status.

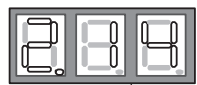

Item number

Display flickers at 1 second intervals.

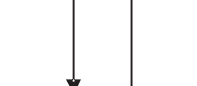

Value

Press *RECALL*.

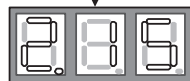

Press *RECALL*.

Press *RECALL*.



SETTING THE MODE DISPLAY

SETTINGS MODE 1 NAVIGATION

< SCREEN 3 >

Setting Mode 1 allows the user to adjust system settings as shown in the tables at the end of this section.

< SCREEN 0 >

-  OFF
-  ON
-  Blink interval:
0.4 sec. On - 0.4 sec. Off

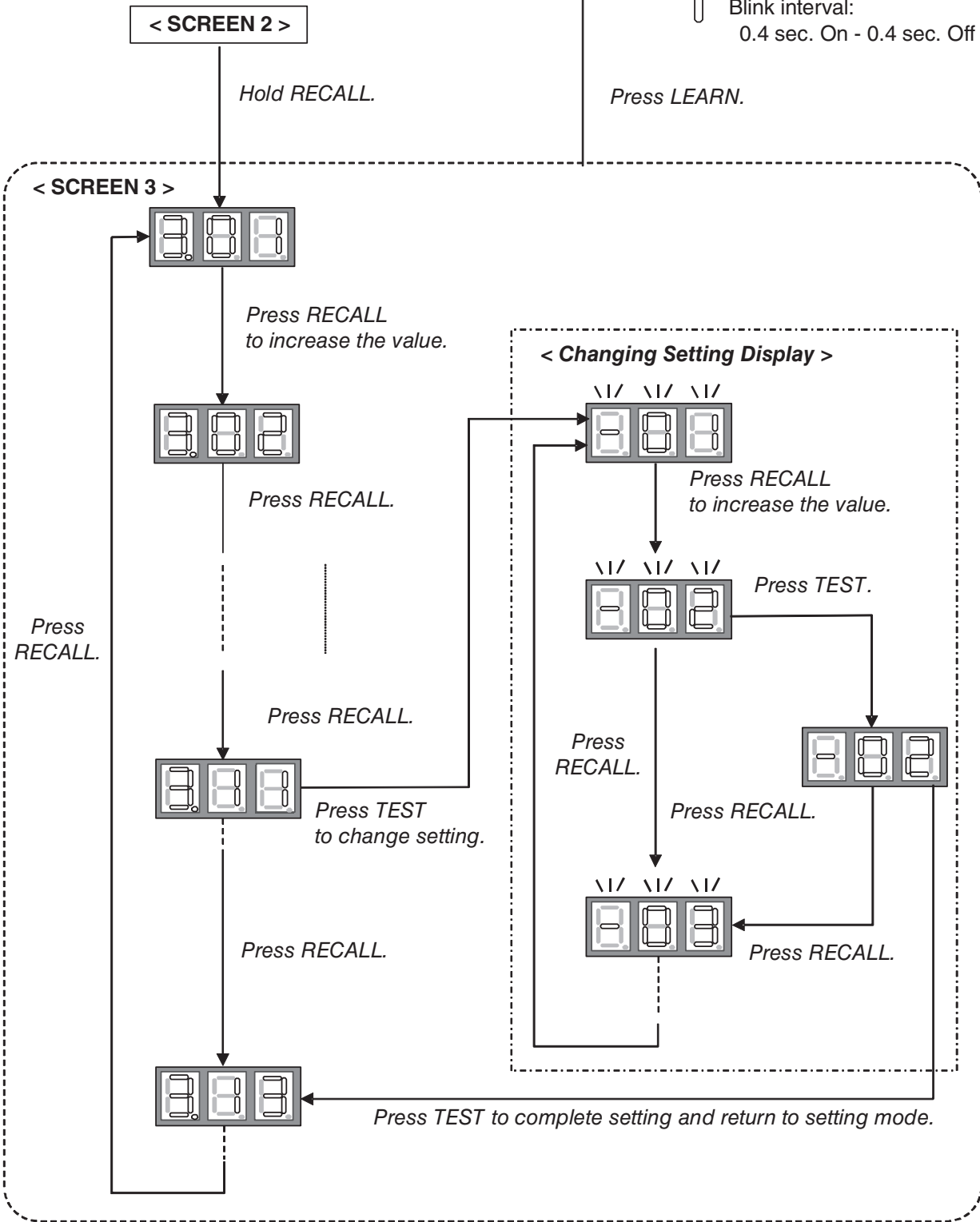

SETTING THE MODE DISPLAY

SETTINGS MODE 2

< SCREEN 4 >

Setting Mode 2 allows the user to change system settings. See table in back of this section.

< SCREEN 0 >

OFF

ON



Blink interval:

0.4 sec. On - 0.4 sec. Off

< SCREEN 3 >

Hold *RECALL* and *TEST*.

Press *LEARN*.

< SCREEN 4 >

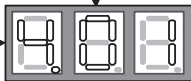

Press *RECALL* to increase the number.

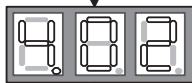

Press *RECALL*.

Press *RECALL*.

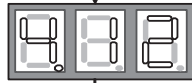

Press *TEST* to change setting.

Press *RECALL*.

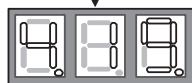

Press *TEST* to complete setting and return to setting mode.

Press *RECALL*.

< Changing setting display >

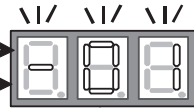

Press *RECALL*.

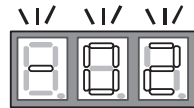

Press *TEST*.

Press *RECALL*.

Press *RECALL*.

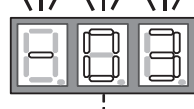

Press *RECALL*.

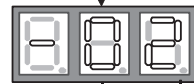

7-SEGMENT DISPLAY

SCREEN 0 (Display FAULT CODE)

Setting No.	Contents	Notes
1	Fault code (present)	

SCREEN 1 (Display FAULT CODES)

Setting No.	Contents	Notes
1	Fault code (latest)	Latest
2	Fault code (2nd)	2nd
3	Fault code (3rd)	3rd
4	Fault code (4th)	4th
5	Fault code (5th)	5th
6	Fault code (6th)	6th

SCREEN 2 (MONITOR MODE)

Setting No.	Contents	Notes
1	Compressor operation time	unit: hr (Multiply by 200)
2	Operation code	0: Stop 1: Cooling Start-up 2: Heating Start-up* ¹ 3: Oil Return Operation 4: Heating Operation* ¹ 5: Defrost Operation* ¹ 6: Cooling Operation
3	Compressor Reduction Mode	0:OFF, 1: ON
4	% Demand	unit: % (Cut off the decimal first place)
5	Act % demand	unit: % (Cut off the decimal first place)
6	Requested ID CFM	unit: CFM (Multiply by 10)
7	Reported ID CFM	unit: CFM (Multiply by 10)
8	Outdoor FAN RPM	unit: RPM (Multiply by 10)
9	Ta (Outdoor Air Temperature)	unit: F
10	Td (Discharge Temperature)	unit: F
11	Tm (Outdoor Coil Temperature)	unit: F
12	Tb (Defrost Sensor Temperature)* ¹	unit: F
13	TI (Liquid Temperature)	unit: F
14	Pressure sensor (Suction Pressure)	unit: PSIG
15	Ts (Suction Temperature)	unit: F

*¹ HP only

7-SEGMENT DISPLAY

SCREEN 3 (SETTING MODE 1)

Setting No.	Contents	Setting *2			Installer/Service Man Notes
1	Cool Airflow Trim High	0:-15% 1:-10% 2:-5% 3:0%	4:5% 5:10% 6:15%		
2	Cool Airflow Trim Int	0:-15% 1:-10% 2:-5% 3:0%	4:5% 5:10% 6:15% 7:20%	8:30% 9:Full	
3	Cool Airflow Trim Low	0:-15% 1:-10% 2:-5% 3:0%	4:5% 5:10% 6:15% 7:20%	8:30% 9:Full	
4	Cool Profiles	0:A 1:B	2:C	3:D	
5	Cool Airflow ON Delay	0:5sec. 1:10sec.	2:20sec.	3:30sec.	
6	Cool Airflow OFF Delay	0:30sec. 1:60sec.	2:90sec.	3:120sec.	
7	Dehumidification	0:STD 1:OFF 2:A 3:B 4:C			
8	Heat Airflow Trim High*1	0:-15% 1:-10% 2:-5% 3:0%	4:5% 5:10% 6:15%		
9	Heat Airflow Trim Int*1	0:-15% 1:-10% 2:-5% 3:0%	4:5% 5:10% 6:15%		
10	Heat Airflow Trim Low*1	0:-15% 1:-10% 2:-5% 3:0%	4:5% 5:10% 6:15%		
11	Heat Airflow ON Delay*1	0:5sec.	1:10sec.	2:15sec.	
12	Heat Airflow OFF Delay*1	0:30sec. 1:50sec.	2:70sec.	3:90sec.	
13	Airflow Trim Offset*3	0:0%	1:+2.5%		
14	Zoning Mode	0:OFF	1:ON		
15	Circulation Selection	0:OFF	1:ON		

NOTE: Parameters as per factory setting are highlighted in bold and underlined.

*1 HP only

*2 The setting items can be different from this table depending on the outdoor unit model revision.

To confirm the setting specifications implemented, please see the attached installation manual, or the setting items displayed on the thermostat.

*3 Used for additional trim setting by adding 2.5% to basic airflow trim setting. This setting affects all trim settings except +15% High (cooling or heating).

SPLIT SYSTEMS

We strongly recommend a bi-annual maintenance checkup be performed before the heating and cooling seasons begin by a qualified servicer.

REPLACE OR CLEAN FILTER

IMPORTANT NOTE: Never operate unit without a filter installed as dust and lint will build up on internal parts resulting in loss of efficiency, equipment damage and possible fire.

An indoor air filter must be used with your comfort system. A properly maintained filter will keep the indoor coil of your comfort system clean. A dirty coil could cause poor operation and/or severe equipment damage.

Your air filter or filters could be located in your air handler, in your furnace, in a blower unit, or in "filter grilles" in your ceiling or walls. The installer of your outdoor unit can tell you where your filter(s) are, and how to clean or replace them.

Check your filter(s) at least once a month. When they are dirty, replace or clean as required. Disposable type filters should be replaced. Reusable type filters may be cleaned.

You may want to ask your dealer about high efficiency filters. High efficiency filters are available in both electronic and non-electronic types. These filters can do a better job of catching small airborne particles.

COMPRESSOR

The compressor motor is hermetically sealed and does not require additional oiling.

MOTORS

Indoor and outdoor fan motors are permanently lubricated and do not require additional oiling.

CLEAN OUTSIDE COIL (QUALIFIED SERVICER ONLY)

 **WARNING**

HIGH VOLTAGE!

DISCONNECT ALL POWER BEFORE SERVICING.
MULTIPLE POWER SOURCES MAY BE PRESENT. FAILURE TO DO SO MAY CAUSE PROPERTY DAMAGE, PERSONAL INJURY OR DEATH.



Air must be able to flow through the outdoor unit of your comfort system. Do not construct a fence near the unit or build a deck or patio over the unit without first discussing your plans with your dealer or other qualified servicer. Restricted airflow could lead to poor operation and/or severe equipment damage.

Likewise, it is important to keep the outdoor coil clean. Dirt, leaves, or debris could also restrict the airflow. If cleaning of the outdoor coil becomes necessary, hire a qualified servicer. Inexperienced people could easily puncture the tubing in the coil. Even a small hole in the tubing could eventually cause a large loss of refrigerant. Loss of refrigerant can cause poor operation and/or severe equipment damage.

Do not use an outdoor unit cover to "protect" the outdoor unit. Outdoor unit fan may sometime start running regardless of demand from thermostat for system reliability reason.

BEFORE CALLING YOUR SERVICER

- Check the thermostat to confirm that it is properly set.
- Wait 15 minutes. Some devices in the outdoor unit or in programmable thermostats will prevent compressor operation for awhile, and then reset automatically. Also, some power companies will install devices which shut off outdoor units for several minutes on hot days. If you wait several minutes, the unit may begin operation on its own.
- Check the electrical panel for tripped circuit breakers or failed fuses. Reset the circuit breakers or replace fuses as necessary.
- Check the disconnect switch near the indoor furnace or blower to confirm that it is closed.
- Check for obstructions on the outdoor unit. Confirm that it has not been covered on the sides or the top. Remove any obstruction that can be safely removed. If the unit is covered with dirt or debris, call a qualified servicer to clean it.
- Check for blockage of the indoor air inlets and outlets. Confirm that they are open and have not been blocked by objects (rugs, curtains or furniture).
- Check the filter. If it is dirty, clean or replace it.
- Listen for any unusual noise(s), other than normal operating noise, that might be coming from the outdoor unit. If you hear unusual noise(s) coming from the unit, call a qualified servicer.

 **CAUTION**

TO AVOID THE RISK OF EQUIPMENT DAMAGE OR FIRE, INSTALL THE SAME AMPERAGE BREAKER OR FUSE AS YOU ARE REPLACING. IF THE CIRCUIT BREAKER OR FUSE SHOULD OPEN AGAIN WITHIN THIRTY DAYS, CONTACT A QUALIFIED SERVICER TO CORRECT THE PROBLEM.

IF YOU REPEATEDLY RESET THE BREAKER OR REPLACE THE FUSE WITHOUT HAVING THE PROBLEM CORRECTED, YOU RUN THE RISK OF SEVERE EQUIPMENT DAMAGE.



Start-up Checklist For Unitary Inverter

**Store in job file*

Date: _____

Model Number: _____

Serial Number: _____

Technician: _____

Pre Start-Up

(Check each item as completed)

- Verify all packaging material has been removed.
- Remove all shipping brackets per installation instructions.
- Verify the job site voltage agrees with the unit serial plate.
- Verify condensate connection is installed per installation instructions.
- Verify proper clearance around the unit for safety, service, maintenance and proper unit operation.
- Verify proper weatherproofing of all ductwork, roof curbs and electrical connections.
- Check line set for leaks.
- Verify gas pressure to the unit is within the range specified on the serial plate.
- Check to ensure that all fan blades and wheels are secure.
- Check refrigerant piping for rubbing and leaks. *Repair if necessary.*
- Check unit wiring to ensure it is not in contact with refrigerant piping or sharp metal edges.
- Check all electrical connections and terminals. *Tighten as needed.*
- Verify that the outdoor unit has been energized for 2 hours.
- Verify all accessories are installed and operating correctly.
- Check filters and replace if necessary.
- Verify the installation of the thermostat. A Daikin approved communicating thermostat is the only approved thermostat for the unitary inverter unit.



Start-up Checklist For Unitary Inverter

Start-Up
(Insert the values as each item is completed.)

ELECTRICAL

Supply Voltage L1 - L2 _____

BLOWER EXTERNAL STATIC PRESSURE

Return Air Static Pressure		IN. W.C.
Supply Air Static Pressure		IN. W.C.
Total External Static Pressure		IN. W.C.
Air Flow		CFM

TEMPERATURES

Outdoor Air Temperature		DB		WB
Return Air Temperature		DB		WB
Cooling Supply Air Temperature		DB		WB

PRESSURES

Suction line		PSIG		°F
Superheat / Subcooling				°F
Liquid line		PSIG		°F

English

NOTE

DAIKIN INDUSTRIES, LTD.

Head office:
Umeda Center Bldg., 2-4-12, Nakazaki-Nishi,
Kita-ku, Osaka, 530-8323 Japan

Tokyo office:
JR Shinagawa East Bldg., 2-18-1, Konan,
Minato-ku, Tokyo, 108-0075 Japan

DAIKIN NORTH AMERICA LLC

Daikin Texas Technology Park,
19001 Kermier Road,
Waller, TX, 77484, U.S.A.

CUSTOMER FEEDBACK

Daikin is very interested in all product comments.

Please fill out the feedback form on the following link:

<https://daikincomfort.com/contact-us>

You can also scan the QR code on the right to be directed to the feedback page.



PRODUCT REGISTRATION

Thank you for your recent purchase. Though not required to get the protection of the standard warranty, registering your product is a relatively short process, and entitles you to additional warranty protection, except that failure by California and Quebec residents to register their product does not diminish their warranty rights.

For Product Registration, please register by following this link:

<https://daikincomfort.com/owner-support/product-registration>

You can also scan the QR code on the right to be directed to the Product Registration page.



NOTE: SPECIFICATIONS AND PERFORMANCE DATA LISTED HEREIN ARE SUBJECT TO CHANGE WITHOUT NOTICE

© 2013, 2017-2019, 2022 **DAIKIN MANUFACTURING COMPANY, L.P.**

Visit our website at www.daikincomfort.com for information on:

- Products
- Warranties
- Customer Services
- Parts
- Contractor Programs and Training
- Financing Options



Intertek