



Installation, Operation, and Maintenance Manual

IOM 1242-4

Group: Chiller

Part Number: IOM1242-4

Date: April 2020

Pathfinder® Air-cooled Screw Chillers

Model AWW
100 to 565 Tons (350 to 1985 kW)
HFC-134a Refrigerant
60/50 Hz

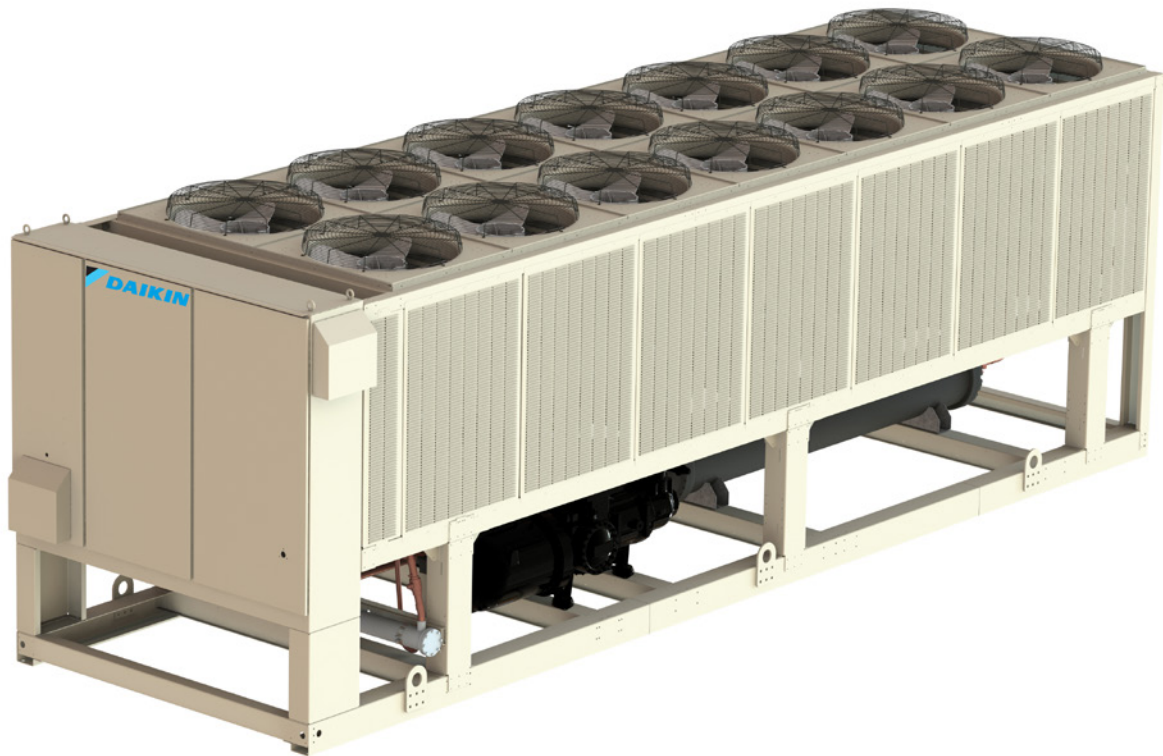

| | |
|---|-----------|
| Introduction | 5 |
| Installation and Application Considerations | 7 |
| Installation and Application Considerations - Remote Evaporators | 25 |
| Dimensions - Remote Evaporators | 32 |
| Dimensional Drawings | 35 |
| Isolator Information | 38 |
| Pressure Drop Data | 39 |
| Controller Operation | 42 |
| Unit Functions | 51 |
| Circuit Functions | 58 |
| Alarms and Events | 68 |
| Using the Controller | 80 |
| Startup and Shutdown | 82 |
| System Maintenance | 87 |
| Appendix | 92 |

Manufactured in an ISO 9001 & ISO 14001 certified facility



©2020 Daikin Applied. Illustrations and data cover the Daikin Applied product at the time of publication and we reserve the right to make changes in design and construction at any time without notice.



Pre-Start Checklist – Screw Chillers

Must be completed, signed and provided to Daikin Applied at least 2 weeks prior to requested start date.

| | | | | |
|---|------------|-----------|------------|-----------------|
| Job Name | | | | |
| Installation Location | | | | |
| Customer Order Number | | | | |
| Model Number(s) | | | | |
| G.O. Number(s) | | | | |
| Chilled Water and Condenser Water for Water-cooled Chiller | Yes | No | N/A | Initials |
| Piping complete | | | | |
| Water strainer(s) installed in piping per manual requirements | | | | |
| Water System – flushed, filled, and vented; Water treatment in place | | | | |
| Cooling tower flushed, filled, vented; Water treatment in place (if applicable) | | | | |
| Pumps installed and operational (rotation checked, strainers installed and cleaned) | | | | |
| Controls operational (3-way valves, face/bypass dampers, bypass valves, etc.) | | | | |
| Water system operated and tested; flow meets unit design requirements | | | | |
| Flow switch(es) - installed, wired, and calibrated | | | | |
| Vent installed on evaporator | | | | |
| Glycol at design % (if applicable) | | | | |
| Electrical | Yes | No | N/A | Initials |
| Building controls operational | | | | |
| *Power leads connected to power block or optional disconnect | | | | |
| Power leads have been checked for proper phasing and voltage | | | | |
| All interlock wiring complete and compliant with Daikin specifications | | | | |
| Power applied at least 24 hours before startup | | | | |
| Oil heaters energized at least 24 hours before startup (not applicable for WWV models) | | | | |
| Chiller components (EXV Sensors Transducers) installed and wired properly | | | | |
| *Wiring complies with National Electrical Code and local codes (see notes) | | | | |
| Remote EXV wired with shielded cable (if applicable) | | | | |
| Miscellaneous | Yes | No | N/A | Initials |
| Unit control switches all off | | | | |
| Remote Evaporator Piping factory reviewed and approved (if applicable) | | | | |
| All refrigerant components/piping leak tested, evacuated and charged | | | | |
| Thermometers, wells, gauges, control, etc., installed | | | | |
| Minimum system load of 80% capacity available for testing/adjusting controls | | | | |
| Document Attached: Technical Data Sheet from Selection Software | | | | |
| Document Attached: Final Order Acknowledgement | | | | |
| Document Attached: Remote evaporator piping approval (if applicable) | | | | |
| <p>Notes: The most common problems delaying start-up and affecting unit reliability are:</p> <ol style="list-style-type: none"> Field installed compressor motor power supply leads too small. Questions: Contact the local Daikin sales representative*. State size, number and type of conductors and conduits installed: <ol style="list-style-type: none"> From Power supply to chiller _____ <p>* Refer to NEC Article 430-22 (a)</p> <ol style="list-style-type: none"> Remote Evaporator piping incomplete or incorrect. Provide approved piping diagrams. Items on this list incorrectly acknowledged may result in delayed start and extra expenses incurred for return trips. | | | | |

Cut Here ✂

Contractor Representative

Signed: _____
 Name: _____
 Company: _____
 Date: _____
 Phone/Email: _____

Daikin Applied Sales Representative

Signed: _____
 Name: _____
 Company: _____
 Date: _____
 Phone/Email: _____

This manual provides installation, operation, and maintenance information for Daikin Pathfinder® model AWV screw chillers with the MicroTech® III controller.

NOTE: Installation and maintenance are to be performed only by qualified personnel who are familiar with local codes and regulations, and experienced with this type of equipment.

 DANGER

LOCKOUT/TAGOUT all power sources prior to starting, pressurizing, de-pressuring, or powering down the Chiller. Failure to follow this warning exactly can result in serious injury or death. Be sure to read and understand the installation, operation, and service instructions within this manual.

 WARNING

Electric shock hazard. Improper handling of this equipment can cause personal injury or equipment damage. This equipment must be properly grounded. Connections to and service of the MicroTech® III control panel must be performed only by personnel that are knowledgeable in the operation of the equipment being controlled.

 CAUTION

Static sensitive components. A static discharge while handling electronic circuit boards can cause damage to the components. Use a static strap before performing any service work. Never unplug any cables, circuit board terminal blocks, or power plugs while power is applied to the panel.

 CAUTION

When moving refrigerant to/from the chiller using an auxiliary tank, a grounding strap must be used. An electrical charge builds when halo-carbon refrigerant travels in a rubber hose. A grounding strap must be used between the auxiliary refrigerant tank and the chiller's end sheet (earth ground), which will safely take the charge to the ground. Damage to sensitive electronic components could occur if this procedure is not followed.

 CAUTION

This equipment generates, uses, and can radiate radio frequency energy. If not installed and used in accordance with this instruction manual, it may cause interference with radio communications. Operation of this equipment in a residential area may cause harmful interference in which case the owner will be required to correct the interference at the owner's own expense.

Daikin Applied disclaims any liability resulting from any interference or for the correction thereof.

HAZARD IDENTIFICATION INFORMATION

 DANGER

Dangers indicate a hazardous situation, which will result in death or serious injury if not avoided.

 WARNING

Warnings indicate potentially hazardous situations, which can result in property damage, severe personal injury, or death if not avoided.

 CAUTION

Cautions indicate potentially hazardous situations, which can result in personal injury or equipment damage if not avoided.

NOTE: Indicates important details or clarifying statements for information presented.

General Description

Daikin Pathfinder® model AWW chillers are complete, self-contained, automatically controlled, liquid-chilling units featuring variable speed screw compressors. All model AWW chillers are equipped with a single evaporator and microchannel condenser coils along with two compressors.

Pathfinder® chillers are designed for outdoor installation only. The chillers use refrigerant HFC-134a that has no ozone depletion level.

Only normal field connections such as water piping, electric power, and control interlocks are required, thereby simplifying installation and increasing reliability. Necessary equipment

protection and operating controls are included.

All Daikin Applied screw chillers must be commissioned by a Daikin Applied service technician or an authorized service provider. Failure to follow this startup procedure can affect the equipment warranty (see “Receiving and Handling” on page 7).

The standard limited warranty on this equipment covers parts that prove defective in material or workmanship. Specific details of this warranty can be found in the warranty statement furnished with the equipment.

NOMENCLATURE

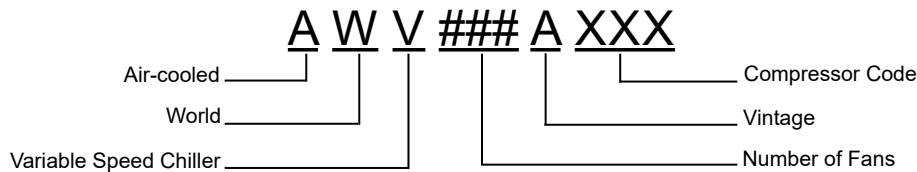

Table 1: Operating Limits for AWW Chillers

| | |
|---|---------------------------------|
| Maximum standby ambient temperature NOTE: Maximum operating ambient temperature is determined by unit configuration. | 130°F (54.4°C) |
| Minimum operating ambient temperature - standard ambient control | 32°F (0°C) |
| Minimum starting ambient temperature - low ambient control option | -10°F (-23.3°C) |
| Minimum operating ambient temperature - low ambient control & integrated waterside economizer options | -20°F (-28.9°C) |
| Leaving chilled water temperature | 40°F to 70°F (4.4°C to 21.1°C) |
| Leaving chilled fluid temperatures (with antifreeze) - NOTE: Unloading is not permitted with fluid leaving temperatures below 25°F (-3.9°C). | 17°F to 70°F (-8.3°C to 21.1°C) |
| Operating chilled water Delta T range | 6°F to 20°F (3.3°C to 11.1°C) |
| Maximum evaporator operating inlet fluid temperature | 88°F (31.1°C) |
| Maximum evaporator non-operating inlet fluid temperature | 100°F (38°C) |

Nameplates

Identification nameplates on the chiller:

- The unit nameplate is located on the exterior of the Unit Power Panel. Both the Model No. and Serial No. are located on the unit nameplate; the Serial No. is unique to the unit. These numbers should be used to identify the unit for service, parts, or warranty questions. This plate also has the unit refrigerant charge and electrical ratings.
- Vessel nameplate is located on the evaporator. They have a National Board Number (NB) and a serial number, either of which identify the vessel (but not the entire unit).
- Compressor nameplate is located on each compressor and gives pertinent electrical information.

Receiving and Handling

The unit should be inspected immediately after receipt for possible damage. All Daikin Applied screw air-cooled chillers are shipped FOB factory and all claims for handling and shipping damage are the responsibility of the consignee.

Startup by a Daikin Applied service representative is included on all Pathfinder® units sold for installation within the U.S. and Canada and must be performed by them to initiate the standard Limited Product Warranty. Startup by any party other than a Daikin Applied service representative will void the Limited Product Warranty. Two-week prior notification of startup is required. The contractor should obtain a copy of the Startup Scheduled Request Form from the sales representative or from the nearest Daikin Applied service office. Completed Request Form and check list on page 3 are required before startup can be scheduled.

Installation and maintenance are to be performed only by qualified personnel who are familiar with local codes and regulations, and experienced with this type of equipment.

CAUTION

Extreme care must be used when rigging the unit to prevent damage to the control panels and unit frame. See the certified dimension drawings included in the job submittal for the weights and center of gravity of the unit. If the drawings are not available, consult the local Daikin Applied sales office for assistance.

WARNING

Sharp edges and coil surfaces are a potential injury hazard. Avoid contact with them.

WARNING

Escaping refrigerant can displace air and cause suffocation. Immediately evacuate and ventilate the equipment area. If the unit is damaged, follow Environmental Protection Agency (EPA) requirements. Do not expose sparks, arcing equipment, open flame or other ignition source to the refrigerant.

DANGER

Improper rigging, lifting, or moving of a unit can result in property damage, severe personal injury or death. Follow rigging and moving instructions carefully.

Avoid rough handling shock due to impact or dropping the unit. Do not push or pull the unit. Never allow any part of the unit to fall during unloading or moving as this can result in serious damage.

To lift a standard AWW unit, lifting tabs with 3" (76 mm) diameter holes are provided on the base of the unit. All lifting holes must be used when lifting the unit. Spreader bars and cables should be arranged to prevent damage to the unit. (see Figure 1).

Figure 1: Rigging for Standard AWW Unit

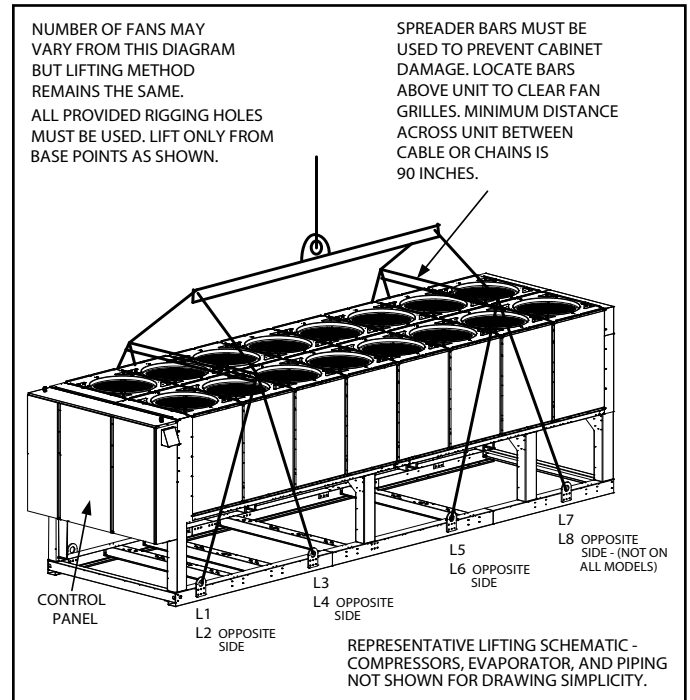

NOTE: 1. Crosswise and lengthwise spreader bars must be used to avoid damage to unit. The spreader bars in Figure 1 are a representation only and may not reflect the appearance of the actual spreader bars needed.

2. Unit with 8 lifting points illustrated above; the actual unit configuration may vary from this diagram. See the dimensional drawing section beginning on page 41 to identify the lifting point locations and weights based on specific unit model.

To lift an AWW unit with the Integrated Waterside Economizer (IWSE) option, lifting tabs with (1) or (2) 3" (76 mm) diameter holes are provided on the base of the unit. For double hole lifting lugs, the left lifting holes must be used when lifting the unit. Spreader bars and cables should be arranged according to the rigging label provided on the control panel to prevent damage to the unit. (see Figure 2 for an example).

Figure 2: Representative Rigging - AWW with IWSE Option

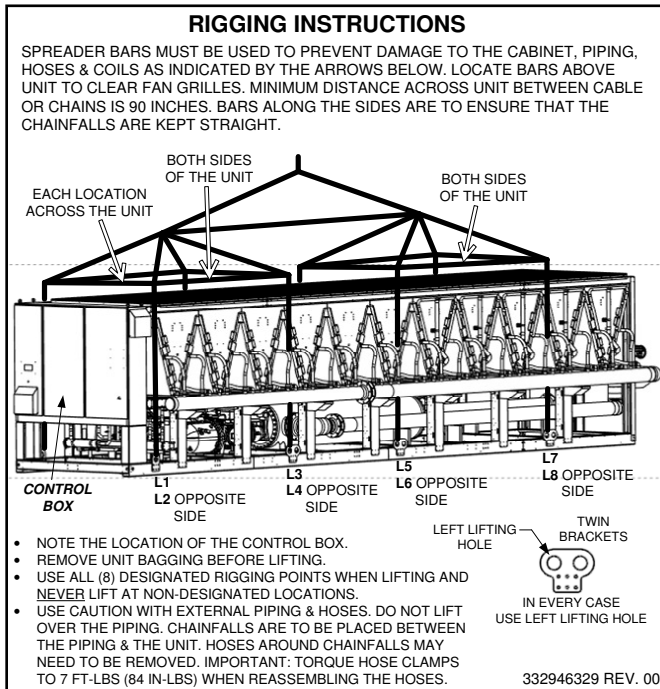

Unit Placement

Locate the unit outdoors and provide proper airflow to the condenser, see [Figure 3](#). Using less clearance than shown for required clearances can cause discharge air recirculation to the condenser and could significantly reduce unit performance.

Pathfinder® units are for outdoor applications and can be mounted either on a roof or at ground level. For roof mounted applications, install the unit on a steel channel or I-beam frame to support the unit above the roof. Spring isolators are recommended for all roof-mounted installations due to vibration transmission considerations. Isolator information can be found on [page 44](#).

For ground level applications, the unit must be installed on a substantial base that will not settle. Use a one-piece concrete slab with footings extended below the frost line. The foundation must be level within 13 mm (1/2 inch) over its length and width and strong enough to support the unit operating weight as listed in Dimensional Drawings beginning on [page 41](#). The addition of neoprene waffle pads (supplied by customer) under the unit may allow water to drain from inside the frame, which can act as a dam. Installation of optional spring or rubber-in-shear isolators can also assist with drainage, see [page 44](#) for information.

On ground level applications, protection against vandalism is recommended; either by the optional factory-installed lower wire mesh guards or louvers, or by a field installed screening fence. Note that the fence must allow free flow of air to the condenser coil for proper unit operation. Upper wire mesh coil guards are standard.

Mounting Hole Access

The inside of the base rail is open to allow access for securing mounting bolts, etc. Mounting location dimensions are given in Dimensional Drawings beginning on [page 41](#).

Service Access

The control panels are located on the end of the chiller and require a minimum of four feet of clearance in front of the panels. Compressors, filter-driers, and manual liquid line shutoff valves are accessible on each side or end of the unit. The evaporator heater is located on the barrel. Do not block access to the sides or ends of the unit with piping or conduit. These areas must be open for service access.

Minimum service clearance spacing on one side of the unit should be increased to 8 feet to allow for coil removal, see [Figure 4](#). The condenser fans and motors can be removed from the top of the unit. The complete fan/motor assembly can be removed for service. The fan blade must be removed for access to wiring terminals at the top of the motor.

⚠ DANGER

Disconnect, lockout and tag all power to the unit before servicing condenser fan motors or compressors. Failure to do so can cause bodily injury or death.

Figure 3: Air Flow

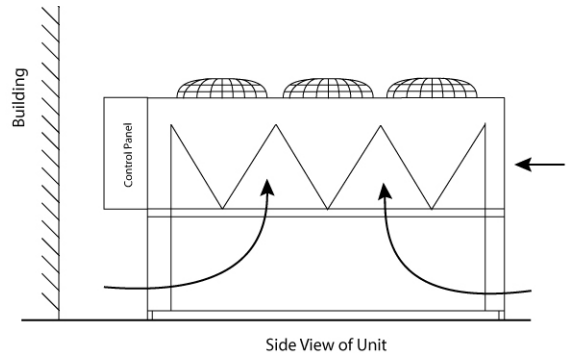

Clearance Requirements

Sufficient clearance must be maintained between the unit and adjacent walls or other units to allow the required unit air flow to reach the coils, see [Figure 3](#) and [Figure 4](#). Failure to do so will result in a capacity reduction and an increase in power consumption. Graphs on the following pages give the minimum clearance for different types of installations and also capacity reduction and power increase if closer spacing is used. The graphs are based on individual cases and should not be combined with other scenarios.

The clearance requirements shown are a general guideline, based on individual cases, and cannot account for all scenarios. Such factors as prevailing winds, additional equipment within the space, design outdoor air temperature, and numerous other factors may require more clearance than what is shown. Additional clearances may be required under

certain circumstances. No solid obstructions are allowed above the unit at any height, see Case 5 on page 15. If low ambient temperature operation is expected, optional louvers should be installed if the unit has no protection against prevailing winds.

Figure 4: Spacing Guidelines for Sufficient Airflow

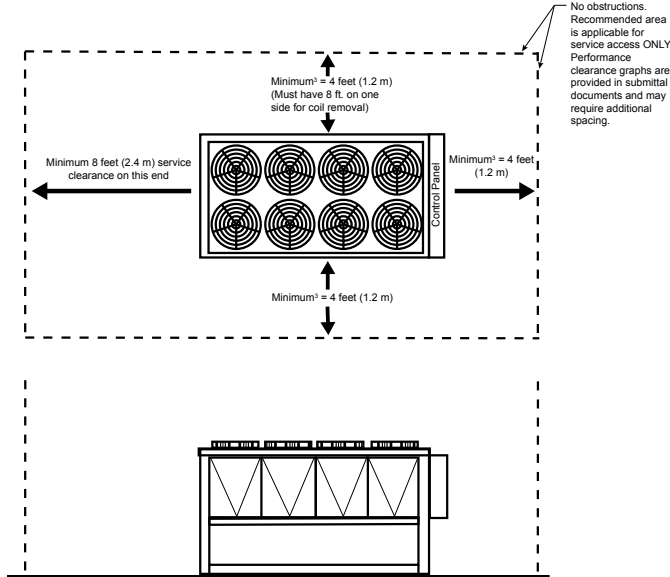

- NOTE:**
1. There should be no obstruction above the fan deck to interfere with fan discharge.
 2. Electrical conduit and field installed electrical devices should not block service access to any chiller components.
 3. Integrated Waterside Economizer (IWSE) units need a minimum side clearance of 5 ft (1.5 m) as measured from the outer base rail of the unit.
 4. For installations of 2 or more units, refer to Case 2 and Case 3.
 5. Stated spacing guidelines are for achieving sufficient airflow without incurring performance losses. See Cases 1 to 5 for capacity reduction and power increases when sufficient airflow cannot be achieved.

Case 1: Building or Wall on One Side of Unit

For most models, maintain a 4 foot minimum from a wall of any height; however, performance may be affected at this distance due to air recirculation and elevated condenser pressure. Assuming all service clearance requirements are met, Figure 6 to Figure 10 depict Case 1 performance adjustments as the wall height and distance increases. For AWW models with IWSE option, the minimum distance from a wall of any height is 5 feet as measured from the outer base rail of the unit and performance adjustments are represented in Figure 11 to Figure 13.

Figure 5: Building or Wall on One Side of Unit

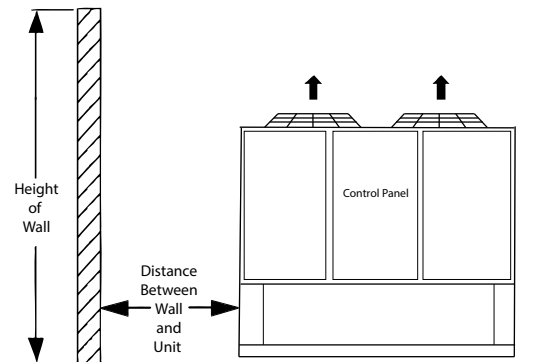

Figure 6: Case 1 for AWW 008-010 Models

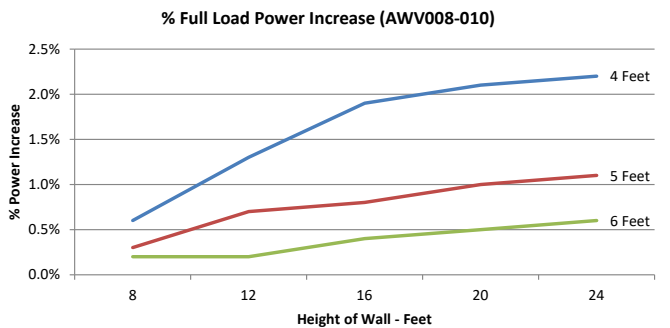
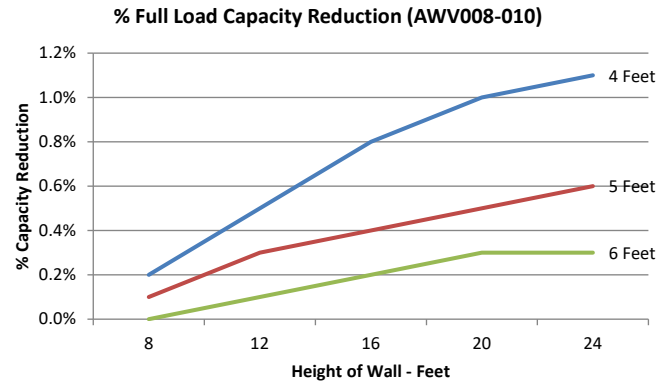

Figure 7: Case 1 for AWW012-014 Models

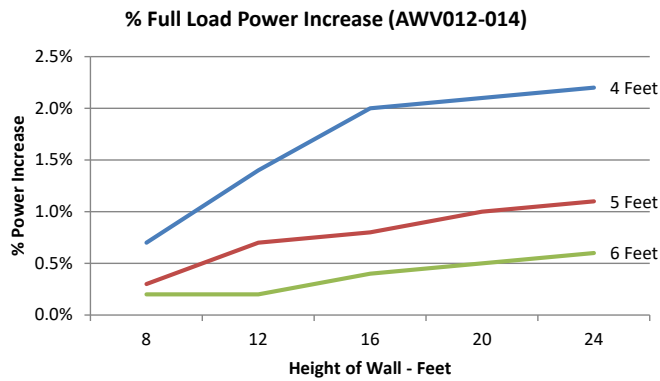
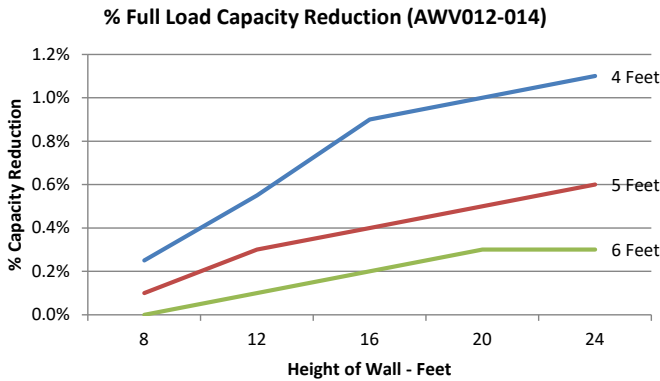

Figure 9: Case 1 for AWW020-024 Models

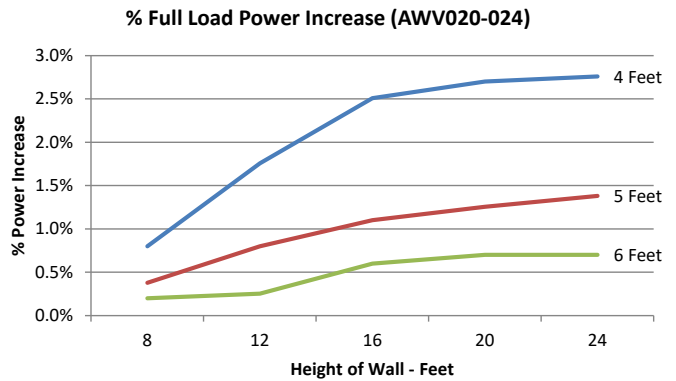
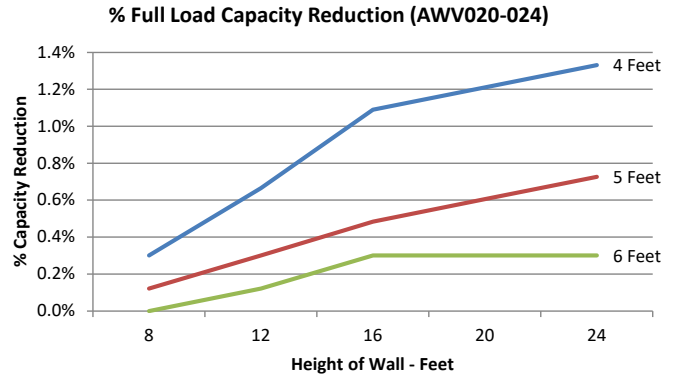

Figure 8: Case 1 for AWW016-018 Models

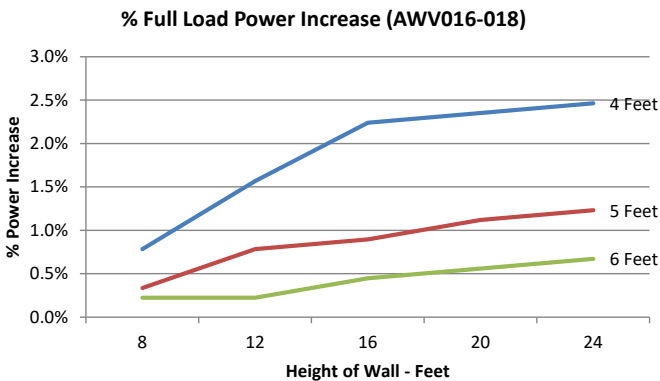
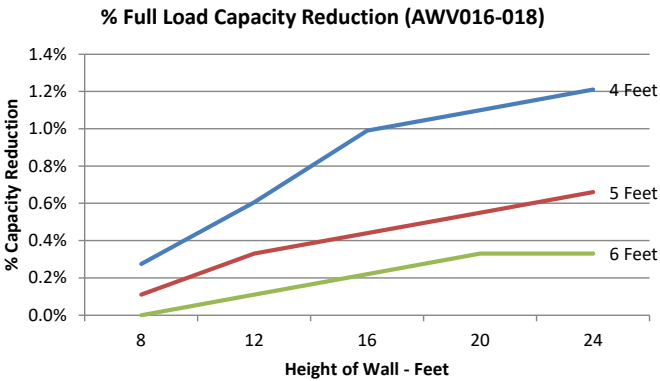

Figure 10: Case 1 for AWW026-030 Models

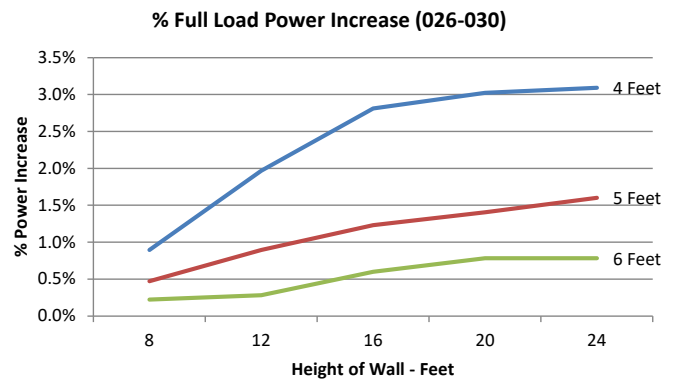
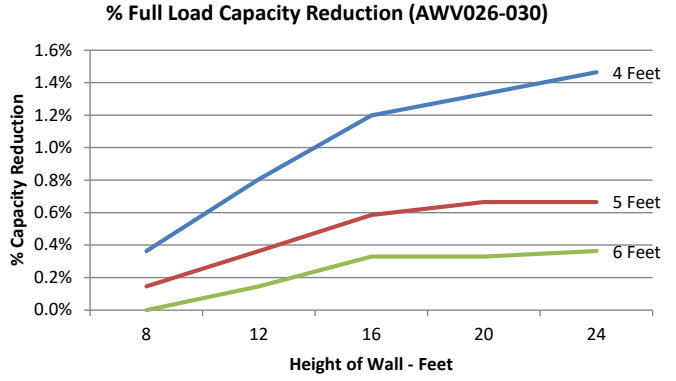
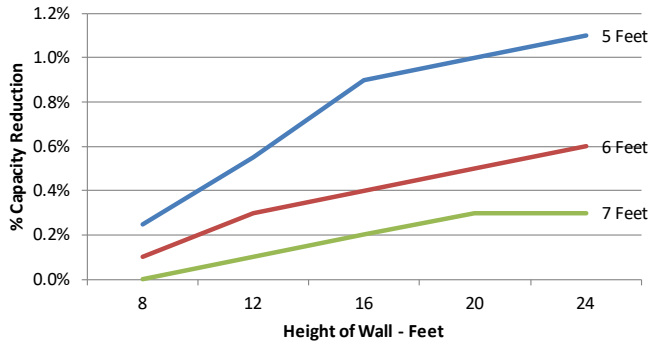

Figure 11: Case 1 for AWV 012-014 Models - IWSE Option
 % Full Load Capacity Reduction (AWV012-014)



% Full Load Power Increase (AWV012-014)

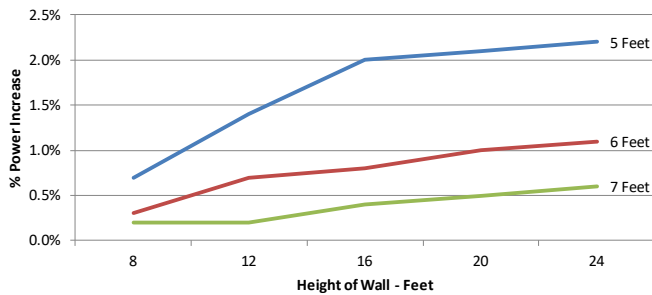
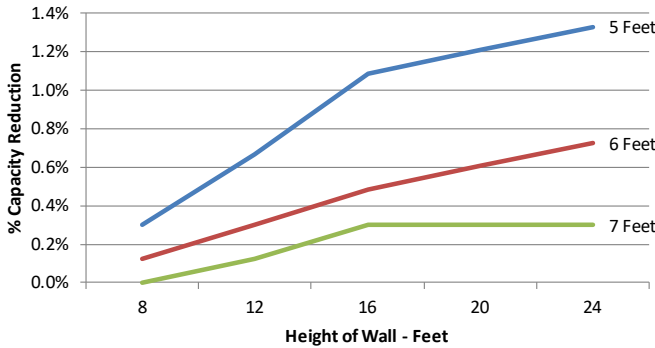

Figure 12: Case 1 for AWV 016-022 Models - IWSE Option

% Full Load Capacity Reduction (AWV016-022)



% Full Load Power Increase (AWV016-022)

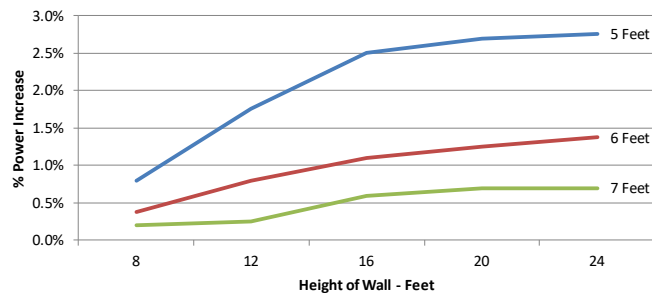
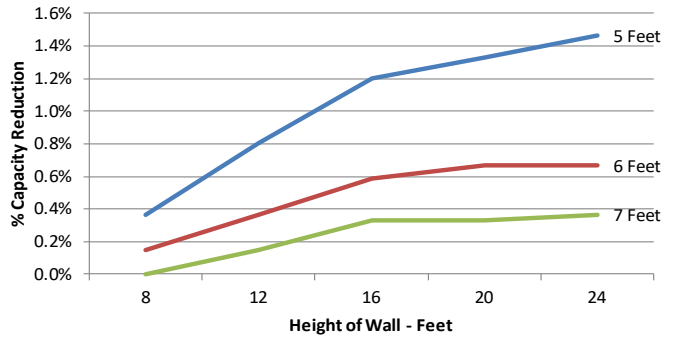
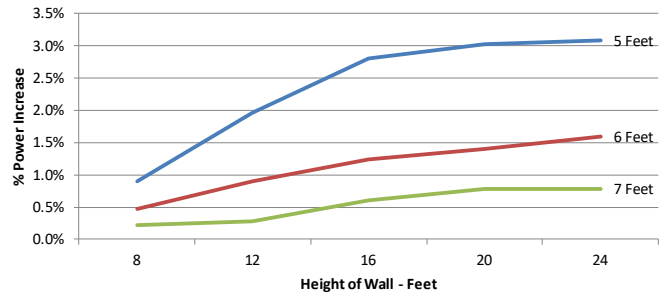

Figure 13: Case 1 for AWV 024-030 Models - IWSE Option
 % Full Load Capacity Reduction (AWV024-030)



% Full Load Power Increase (AWV024-030)



Case 2: Two Units Side-by-Side

For most models, there must be a minimum of 6 feet between two units placed side-by-side; however, performance may be affected at this distance due to air recirculation and elevated condenser pressure. Assuming all service clearance requirements are met, Figure 15 and Figure 16 depict Case 2 performance adjustments as the distance between two units increases. For AWV models with IWSE option, the minimum distance between two units side-by-side is 8 feet as measured from the outer base rail of the unit and performance adjustments are represented in Figure 17 and Figure 18.

Figure 14: Two Units, Side-by-Side

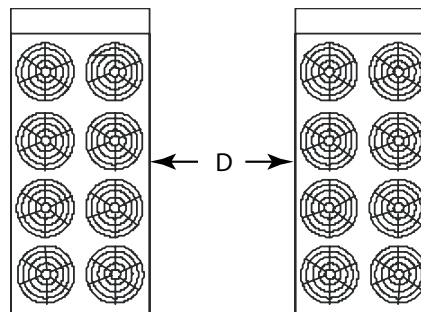

Figure 15: Case 2 - Full Load Capacity Reduction

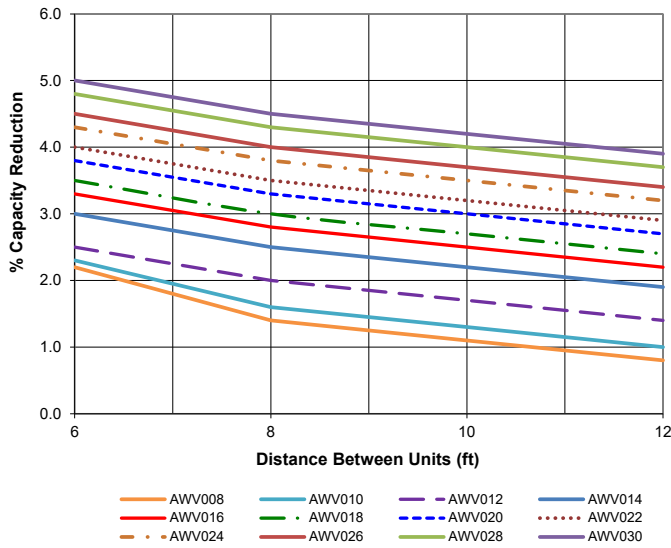

Figure 17: Case 2 - Full Load Capacity Reduction - IWSE Option

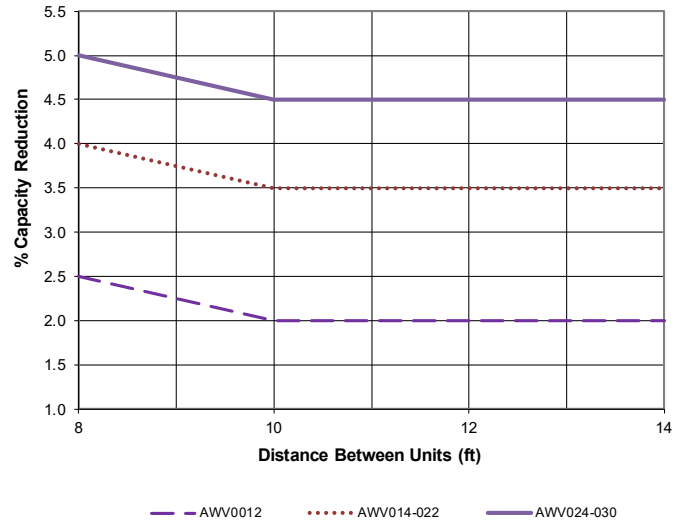

Figure 16: Case 2 - Power Increase

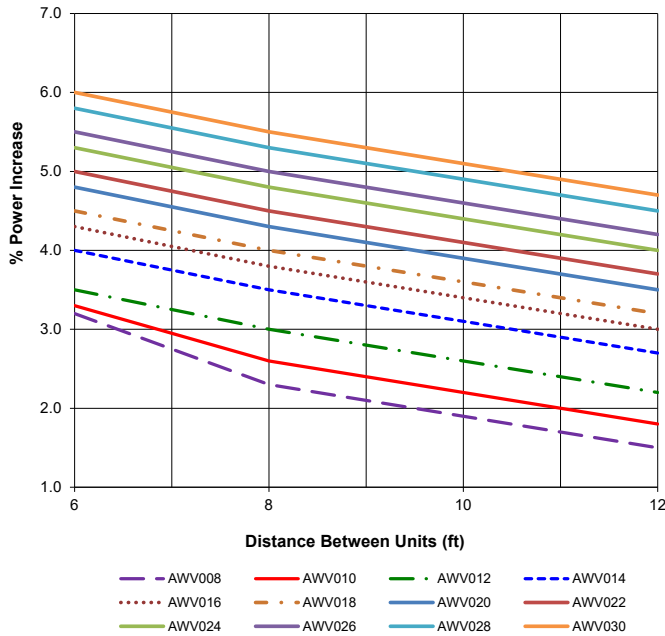
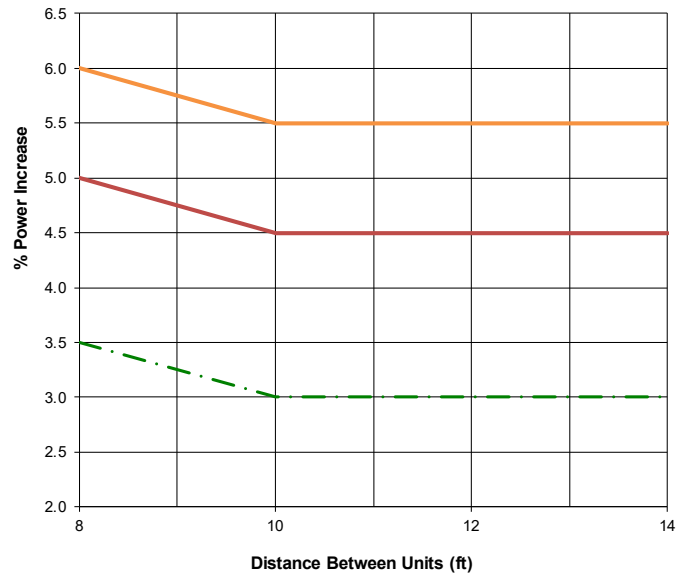

Figure 18: Case 2 - Power Increase - IWSE Option



Case 3: Three or More Units, Side-by-Side

For most models, there must be a minimum of 8 feet between any units placed side-by-side; however, performance may be affected at this distance. Figure 20 and Figure 21 depict Case 3 performance adjustments as the distance between units increases. For AWW models with IWSE option, the minimum distance between multiple units is 10 feet as measured from the outer base rail of the unit and performance adjustments are represented in Figure 22 and Figure 23.

NOTE: Data in Figure 20 to Figure 23 is for the middle unit with a unit on each side. See Case 2 adjustment factors for the two outside units.

Figure 19: Three or More Units, Side-by-Side

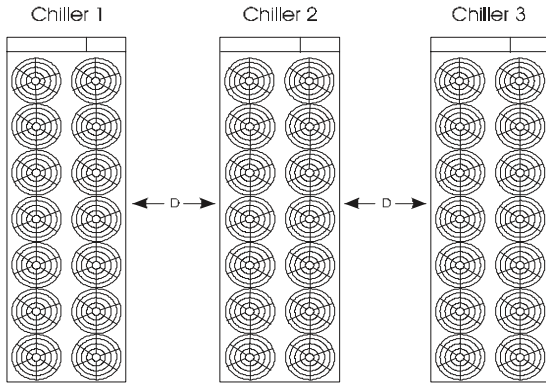

Figure 20: Case 3 - Full Load Capacity Reduction

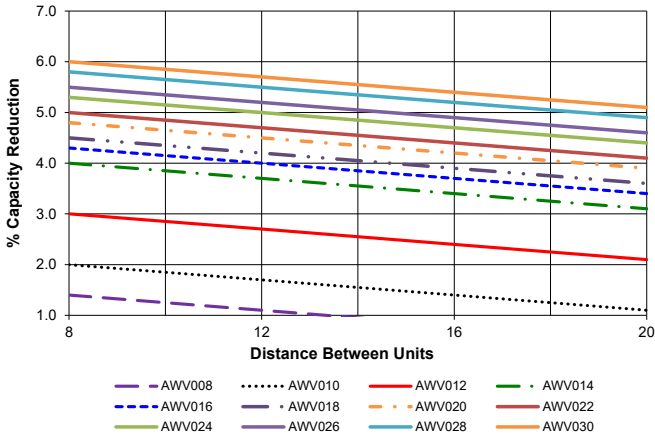

Figure 21: Case 3 - Power Increase

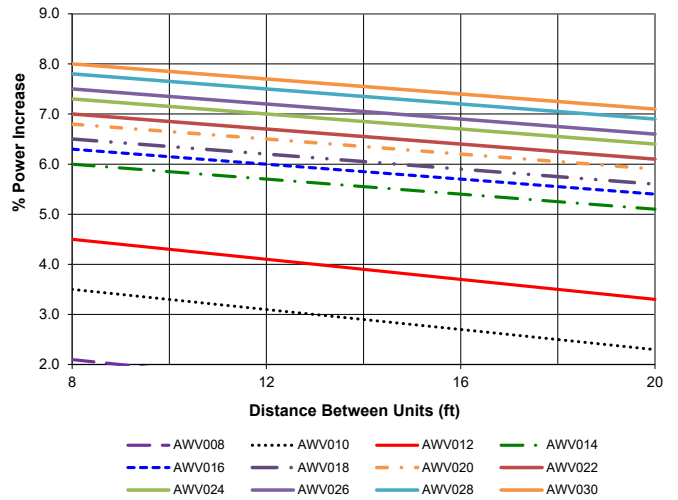

Figure 22: Case 3 - Full Load Capacity Reduction - IWSE Option

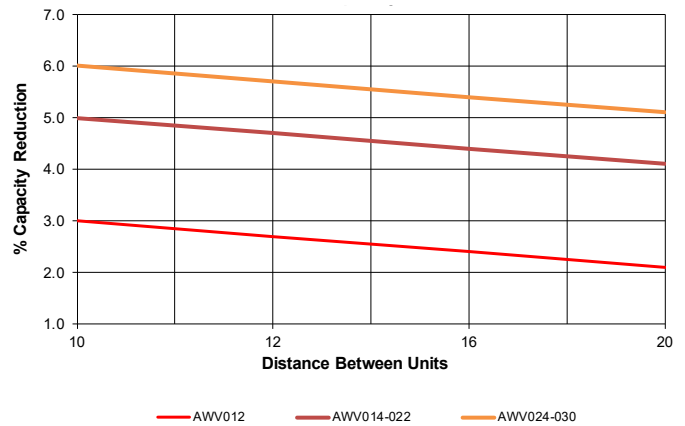

Figure 23: Case 3 - Power Increase - IWSE Option

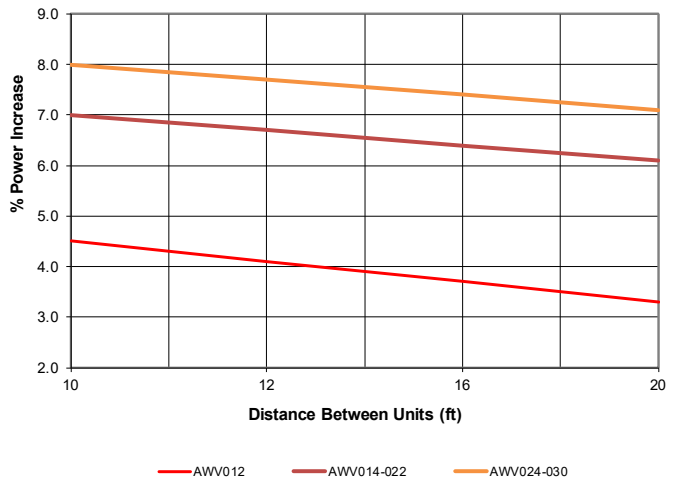

Figure 24: Case 4: Open Screening Walls

Decorative screening walls are often used to help conceal a unit either on grade or on a rooftop. When possible, design these walls such that the combination of their open area and distance from the unit (see Figure 25) do not require performance adjustment. If the wall opening percentage is less than recommended for the distance to the unit, it should be considered as a solid wall. It is assumed that the wall height is equal to or less than the unit height when mounted on its base support. If the wall height is greater than the unit height, see Case 5: Pit/Solid Wall Installation. The distance from the sides of the unit to the side walls must be sufficient for service, such as opening control panel doors. For uneven wall spacing, the distance from the unit to each wall can be averaged providing no distance is less than 4 feet for most models and 5 feet as measured from the outer base rail of the unit for IWSE models. Values are based on walls on all four sides.

Figure 25: Allowable Wall Open Area

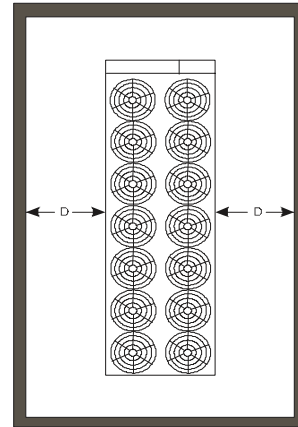

Figure 26: Case 4 - Adjustment Factor

Wall Free Area vs. Distance

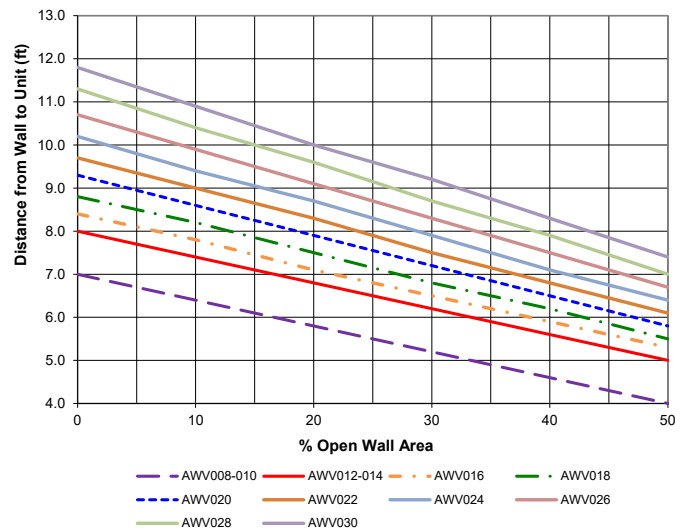
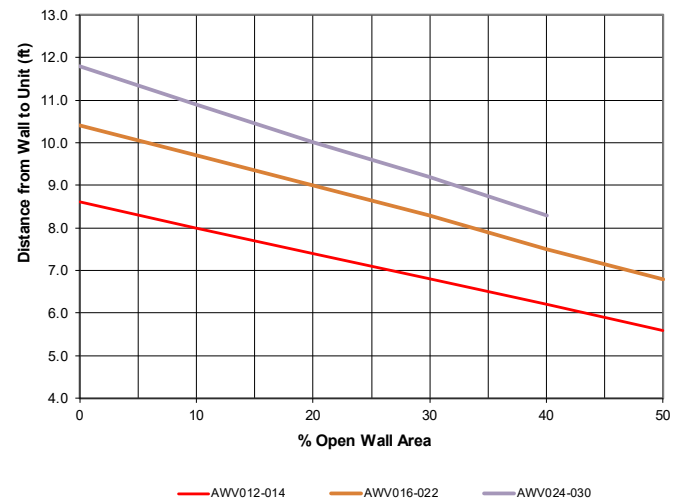

Figure 27: Case 4 - Adjustment Factor - IWSE Option

Wall Free Area vs. Distance



Case 5: Pit/Solid Wall Installation

Pit installations can cause operating problems resulting from air recirculation and restriction and require care that sufficient air clearance is provided, safety requirements are met and service access is provided. A solid wall surrounding a unit is substantially a pit and this data should be used. Derates are based on single chiller installation only. For IWSE chillers, distances are measured from the outer base rail of the unit.

Steel grating is sometimes used to cover a pit to prevent accidental falls or trips into the pit. The grating material and installation design must be strong enough to prevent such accidents, yet provide abundant open area to avoid recirculation problems. Have any pit installation reviewed by the Daikin Applied sales representative prior to installation to ensure it has sufficient air-flow characteristics and approved by the installation design engineer to avoid risk of accident.

Figure 28: Pit Installation

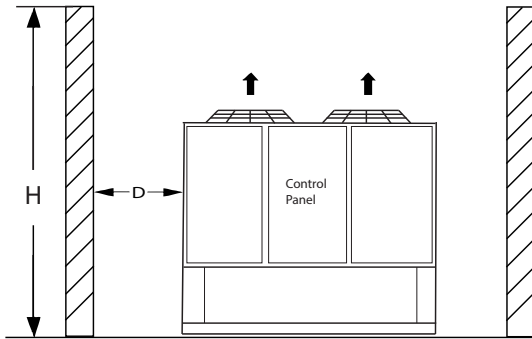

Figure 29: Case 5 for AWW008-010

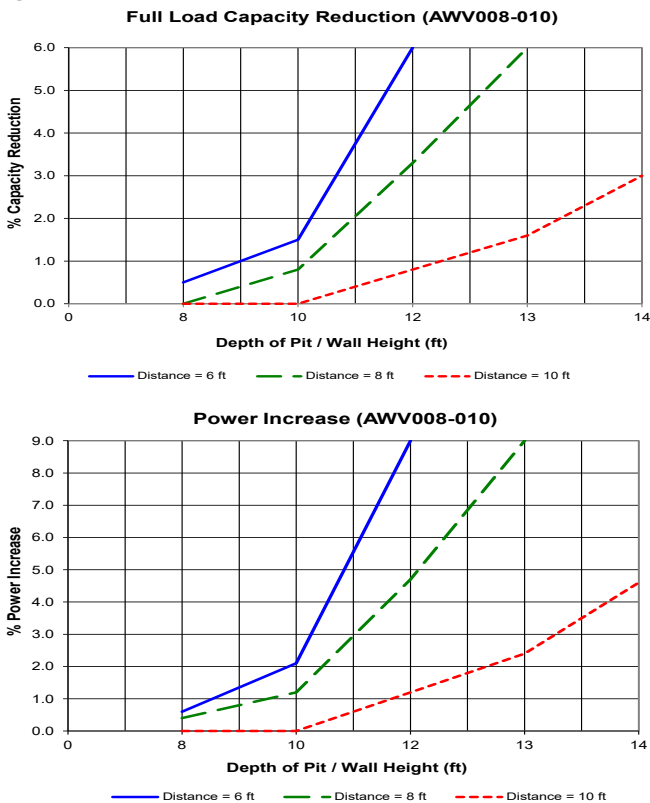

Figure 30: Case 5 for AWW012-014

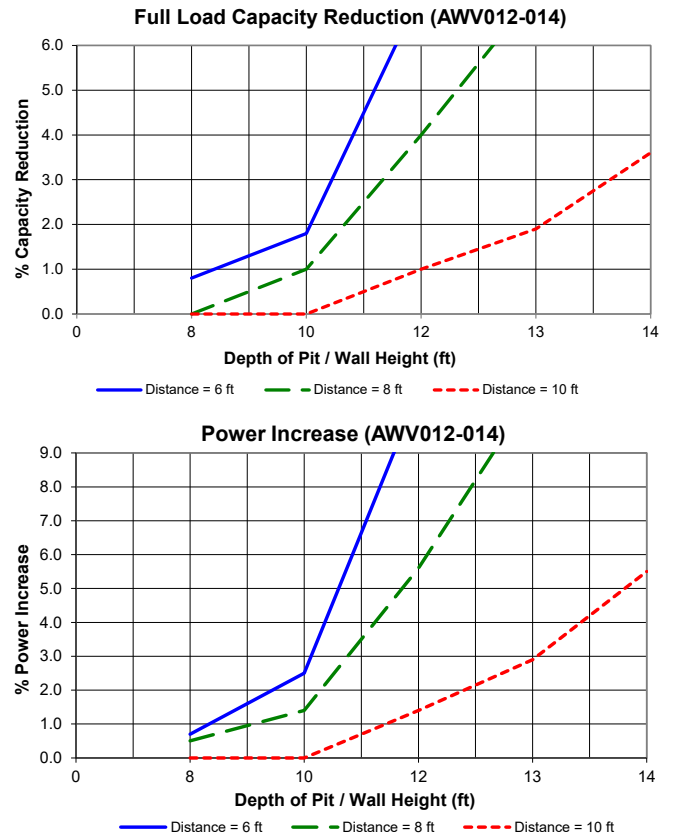

Figure 31: Case 5 for AWW016-018

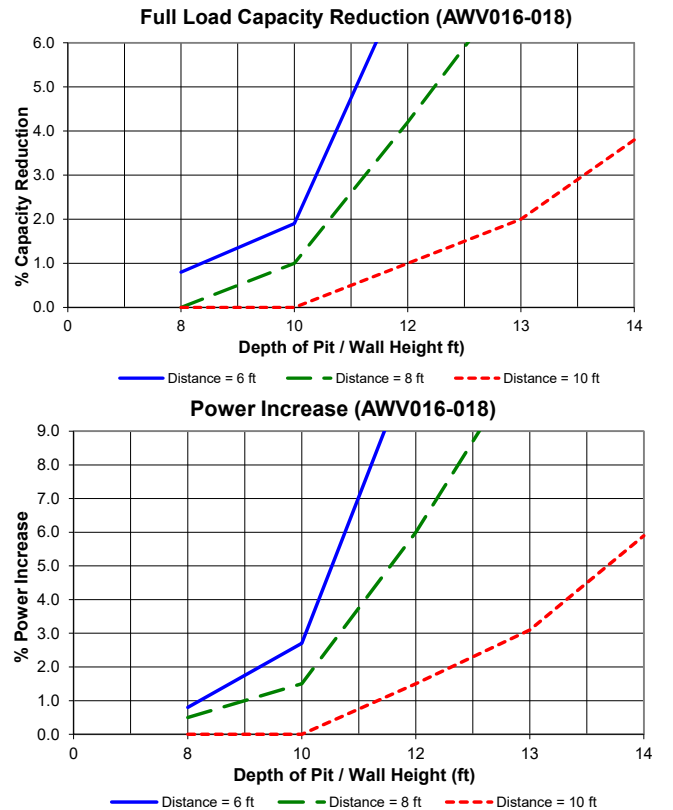

Figure 32: Case 5 for AWW020-024

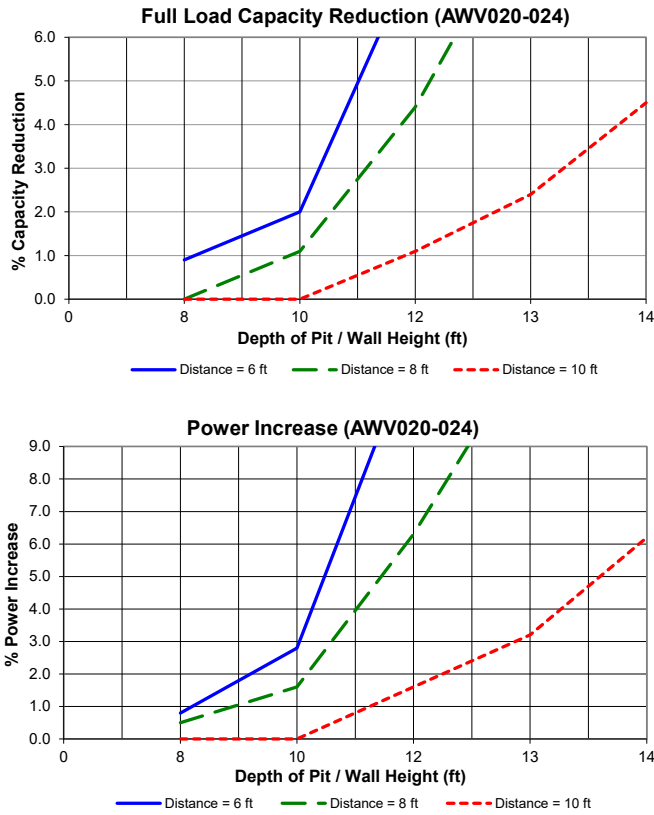

Figure 34: Case 5 for AWW012-014 - IWSE Option

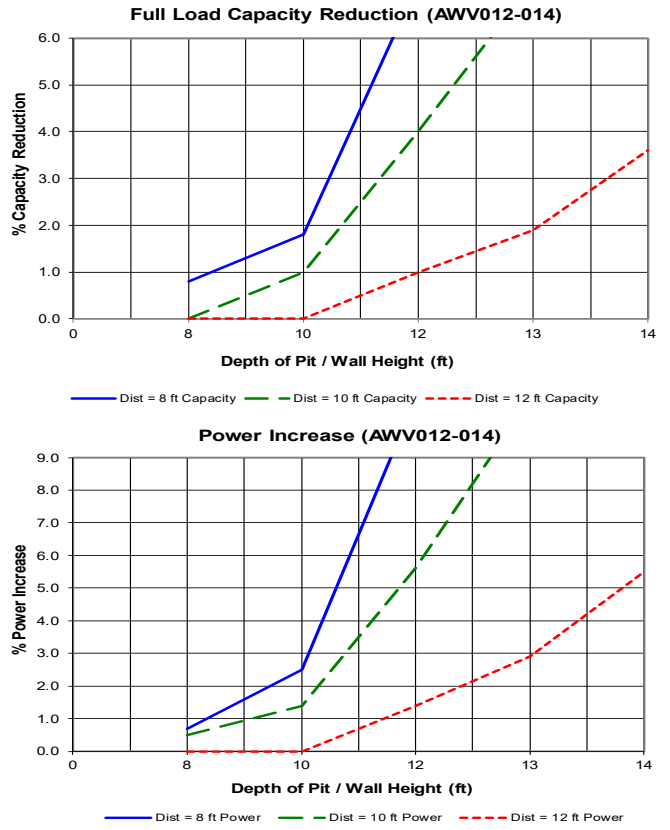

Figure 33: Case 5 for AWW026-030

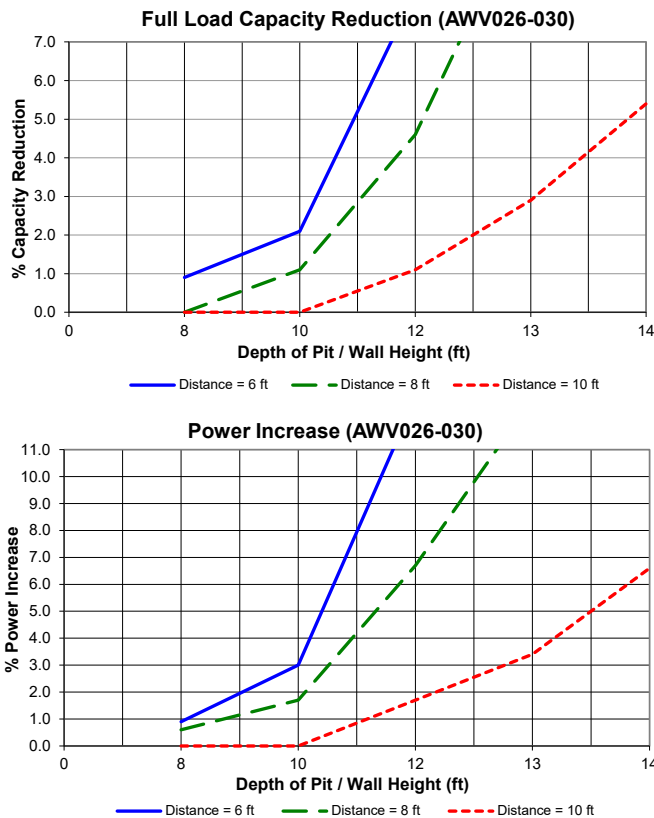

Figure 35: Case 5 for AWW016-022 - IWSE Option

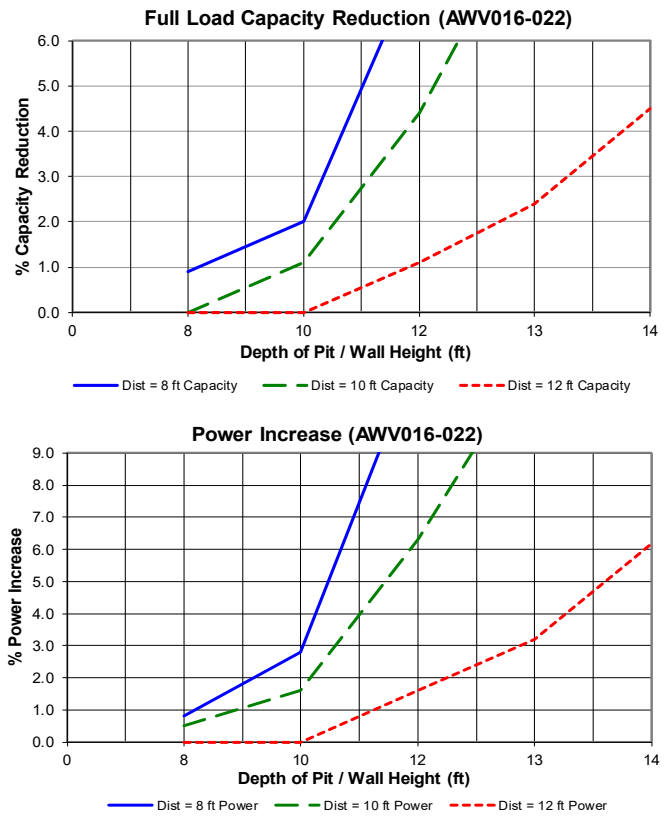
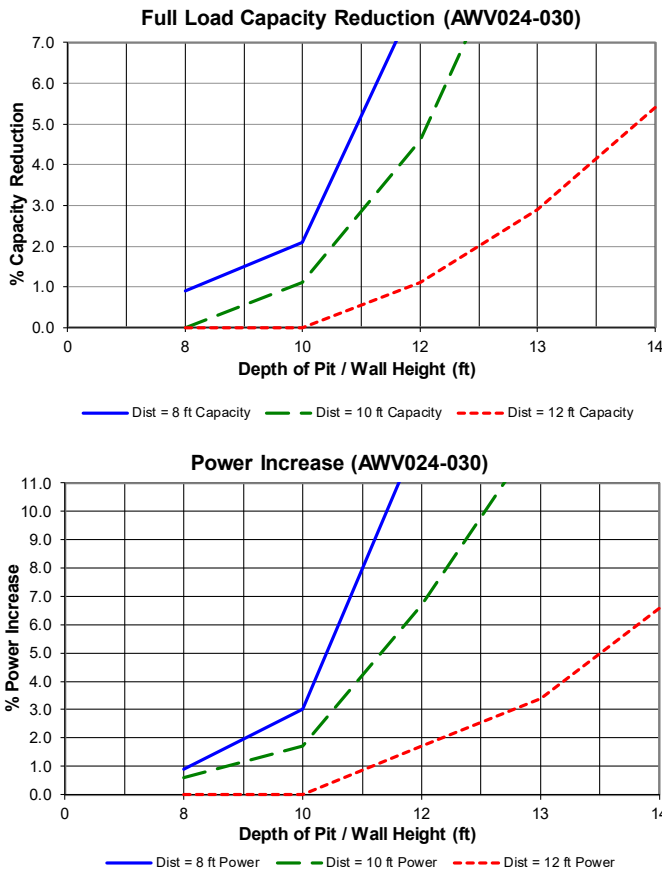

Figure 36: Case 5 for AWW024-030 - IWSE Option



Chilled Water Piping

Startup procedures should confirm that the chilled water piping system had been properly flushed out before being connected to the chiller vessel.

All evaporators have OGS-type grooved water connections (adhering to Standard AWWA C606) or optional flange connections. The installing contractor must provide matching mechanical connections. PVC and CPVC piping should not be used. Be sure water inlet and outlet connections match certified drawings and nozzle markings.

CAUTION

To prevent damage to the evaporator and potential chiller failure, a supply strainer is required in the inlet water piping which connects to the evaporator. This strainer must be installed prior to operation of the chilled liquid pumps.

Field installed water piping to the chiller **must** include:

- A cleanable strainer installed at the water inlet to the evaporator or IWSE connection to remove debris and impurities before they reach the evaporator. Install cleanable strainer within 5 feet (1500 mm) of pipe length from the evaporator inlet connection and downstream of any welded connections (no welded connections between strainer and evaporator). AWW models require a strainer as specified in Inlet Strainer Guidelines on [page 18](#).

- A water flow switch must be installed in the horizontal piping of the supply (evaporator outlet) water line to avoid evaporator freeze-up under low or no flow conditions. See [page 19](#) for more information.
- Purge air from the water system before unit startup to provide adequate flow through the evaporator.
- Piping for units with brazed plate evaporators must have a drain and vent connection provided in the bottom of the lower connection pipe and to the top of the upper connection pipe, respectively, see [Figure 37](#). These evaporators do not have drain or vent connections due to their construction.
- Adequate piping support, independent from the unit, to eliminate weight and strain on the fittings and connections.

It is **recommended** that the field installed water piping to the chiller include:

- Thermometers at the inlet and outlet connections of the evaporator.
- Water pressure gauge connection taps and gauges at the inlet and outlet connections of the evaporator for measuring water pressure drop.
- Shutoff valves to isolate the unit from the piping during unit servicing.
- Minimum bends and changes in elevation to minimize pressure drop.
- An expansion tank and regulating valve to maintain adequate water pressure. Tank becomes required for closed loop systems based on water volume and temperature ranges.
- Vibration eliminators in both the supply and return water lines to reduce transmissions to the building.
- Flushing the system water piping thoroughly **before** making connections to the unit evaporator.
- Piping insulation, including a vapor barrier, helps prevent condensation and reduces heat loss.
- Regular water analysis and chemical water treatment for the evaporator loop is recommended immediately at equipment startup.

WARNING

Daikin Applied recommends against the use of PVC and CPVC piping for chilled water systems. In the event the pipe is exposed to POE oil used in the refrigerant system, the pipe can be chemically damaged and pipe failure can occur.

Figure 37: Typical Chilled Water Piping, Braze Plate

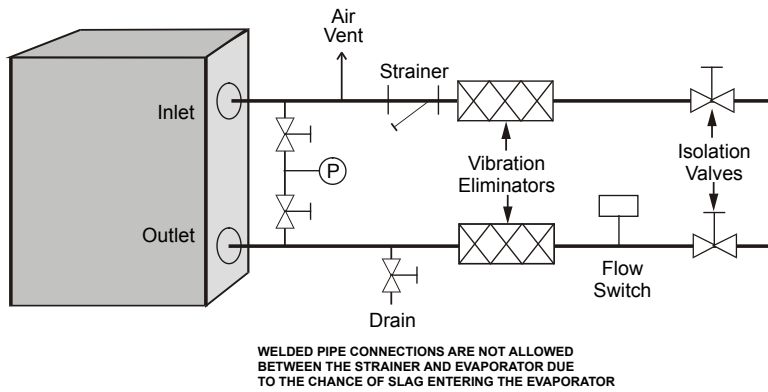
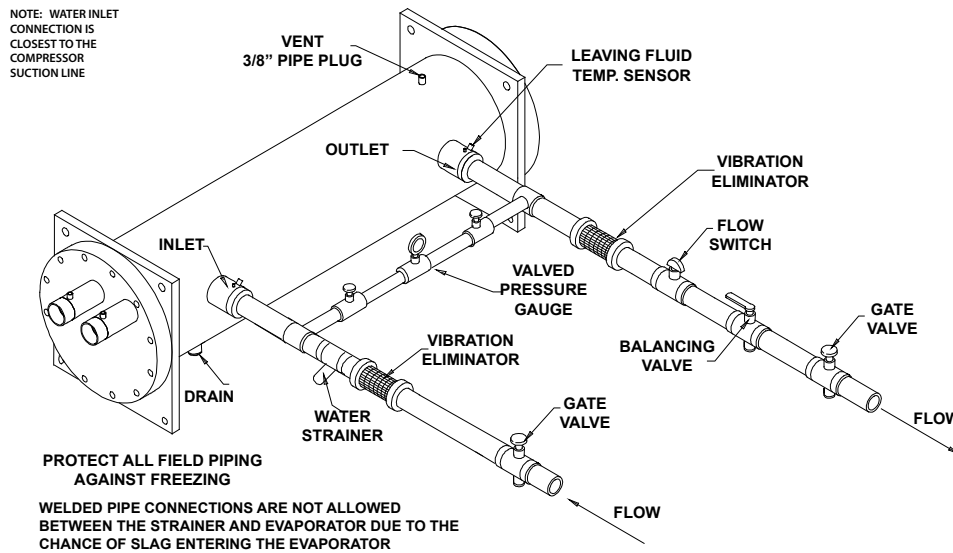

Figure 38: Typical Chilled Water Piping, Shell and Tube Evaporator



Inlet Strainer Guidelines

An inlet water strainer kit must be installed in the chilled water piping within 5 feet of the evaporator inlet or IWSE connection. Two paths are available to meet this requirement:

1. A field-installed kit shipped loose with the unit is available for all unit sizes and consists of:
 - Y-type area strainer with 304 stainless steel perforated basket, Grooved pipe connections and strainer cap
 - a strainer with perforations no larger than 0.031" (1/32", 0.8 mm) diameter for AWW models with the IWSE option
 - a strainer with perforations no larger than 0.063" (1/16", 1.6 mm) diameter for AWW models with a braze plate evaporator
 - a strainer with perforations no larger than 0.125" (1/8", 3.2 mm) diameter for AWW models with a direct expansion evaporator
 - Extension pipe with two couplings that may be used for gauges and sensors. The pipe provides sufficient

clearance from the evaporator for strainer basket removal.

- ½-inch blowdown valve
- Two grooved clamps

The strainer is sized per [Table 2](#). Connection sizes are given in the Pressure Drop Data section on [page 45](#).

2. A field-supplied strainer to same specifications as factory installed option.

Table 2: Strainer Sizing Data

| Application | Strainer Size (in.) | Maximum Perforation Size in. (mm) | Strainer Weight (lbs) |
|---------------------|---------------------|-----------------------------------|-----------------------|
| IWSE | 6 | 0.031" (1/32", 0.8 mm) | 154 |
| | 8 | | 273 |
| Braze Plate Evap | 6 | 0.063" (1/16", 1.6 mm) | 120 |
| Shell and Tube Evap | 6 | 0.125" (1/8", 3.2 mm) | 120 |
| | 8 | | 220 |
| | 10 | | 514 |

Installing Inlet Strainer (Field-installed Kit)

The extension pipe is located adjacent to the evaporator with the strainer then mounted to it. The strainer must be mounted per manufacturer's instruction with the arrows in the direction of flow; inlet and outlet are noted along with the arrows.

Use one grooved clamp to mount the extension pipe to the evaporator and the second to mount the strainer to the pipe. The clamps to mount the field piping to the strainer are field supplied. The piping and strainer must be supported to prevent any stress on the evaporator nozzle.

System Water Volume

All chilled water systems need adequate time to recognize a load change, respond to that load change and stabilize, without undesirable short cycling of the compressors or loss of control. In air conditioning systems, the potential for short cycling usually exists when the building load falls below the minimum chiller plant capacity or on close-coupled systems with very small water volumes. Some of the things the designer should consider when looking at water volume are the minimum cooling load, the minimum chiller plant capacity during the low load period and the desired cycle time for the compressors.

Assuming that there are no sudden load changes and that the chiller plant has reasonable turndown, a rule of thumb of "gallons of water volume equal to two to three times the chilled water gpm flow rate" is often used. A storage tank may have to be added to the system to reach the recommended system volume. Refer to Daikin Applied Chiller Application Guide, AG 31-003, for method of calculating "Minimum Chilled Water Volume".

The water quality provided by the owner/occupant/operator/user to a chiller system should minimize corrosion, scale buildup, erosion, and biological growth for optimum efficiency of HVAC equipment without creating a hazard to operating personnel or the environment. Strainers must be used to protect the chiller systems from water-borne debris. Daikin will not be responsible for any water-borne debris damage or water side damage to the chiller heat exchangers due to improperly treated water.

Water systems should be cleaned and flushed **prior** to chiller installation. Water testing and treatment should be verified during initial chiller installation/commissioning and maintained on a continuous basis by water treatment professionals (see Limited Product Warranty).

CAUTION

The improper use of detergents, chemicals, and additives in the chiller system water may adversely affect chiller performance and potentially lead to repair costs not covered by warranty. Any decision to use these products is at the discretion of the owner/occupant/operator/user as such they assume full liability/responsibility for any damage that may occur due to their use.

Flow Switch

A flow switch must be included in the chilled water system to prove that there is adequate water flow to the evaporator before the unit can start, or to shut down the unit if water flow is interrupted. A solid state, thermal dispersion flow switch that is factory-mounted in the chiller leaving water nozzle and factory-wired is available. A field-installed version is also available as an option.

Installation should be per manufacturer's instructions included with the switch. Flow switches should be calibrated to shut off the unit when operated below the minimum flow rate for the unit. Flow switch installation and calibration is further discussed on [page 90](#).

Evaporator Freeze Protection

Evaporator freeze-up can be a concern in the application of air-cooled water chillers in areas experiencing below freezing temperatures. To protect against freeze-up, insulation and an electric immersion heater are furnished with the evaporator. This helps protect the evaporator down to -20°F (-29°C) ambient air temperature. Although the evaporator is equipped with freeze protection, it does not protect water piping external to the unit or the evaporator itself if there is a power failure or heater burnout, or if the chiller is unable to control the chilled water pumps. Use one of the following recommendations for additional protection:

- If the unit will not be operated during the winter, drain evaporator and chilled water piping and flush with glycol. Drain and vent connections are provided on the evaporator for this purpose.
- Add a year-round glycol solution to the chilled water system to provide freeze protection. Freeze point should be approximately 10°F (5.6°C) below minimum design ambient temperature or 10°F (5.6°C) below the lowest design leaving water temperature, whichever is lower. The use of glycol antifreeze is generally considered the safest protection against freeze-up; however, it will reduce the performance of the unit, depending on the concentration. Take this into consideration during initial system design and selection. On glycol applications, a minimum fluid concentration should be based on Burst Protection limits.
- The field addition of thermostatically controlled heat tracing and insulation to exposed piping, dependent on power availability.
- Continuous circulation of water through the chilled water piping and evaporator, with ability to control temperature within chiller safety limits. (Dependent on power availability).
- The evaporator immersion heater is factory-wired to the 115-volt circuit in the control box. This power can be supplied from a separate source, or it can be supplied from the control circuit. Operation of the heater cable is automatic through the fluid sensing thermostat that energizes the evaporator heater cable for protection against freeze-up. Unless the evaporator is drained in

the winter, the disconnect switch to the evaporator heater must be closed. Conversely, do not apply heat to the evaporator if it is drained.

Chilled Water Pump

It is important that the chilled water pumps be wired to, and controlled by, the chiller’s microprocessor. The chiller controller has the capability to selectively send the signal to a pump relay (by others) to start pump A or B or automatically alternate pump selection and also has standby operation capability. The controller will energize the pump whenever at least one circuit on the chiller is enabled to run, whether there is a call for cooling or not. This helps ensure proper unit startup sequence. To help prevent evaporator freeze-up, the pump will also be turned on when the water temperature is equal to or goes below the Freeze Set Point for at least three seconds. Connection points are shown in the Field Wiring Diagrams on [page 24](#) and [page 25](#).

⚠ CAUTION

Adding glycol or draining the system is the recommended method of freeze protection. If the chiller does not have the ability to control the pumps and the water system is not drained in temperatures below freezing, catastrophic evaporator failure may occur.

Failure to allow pump control by the chiller may cause the following problems:

1. If any device other than the chiller attempts to start the chiller without first starting the pump, the chiller will lock out on the No Flow alarm and require manual reset.
2. If the evaporator water temperature drops below the “Freeze Set Point” the chiller will attempt to start the water pumps to avoid evaporator freeze. If the chiller does not have the ability to start the pumps, the chiller will alarm due to lack of water flow.
3. If the chiller does not have the ability to control the pumps and the water system is not to be drained in temperatures below freezing, the chiller may be subject to catastrophic evaporator failure due to freezing. The freeze rating of the evaporator is based on the immersion heater and pump operation. The immersion heater itself may not be able to properly protect the evaporator from freezing without circulation of water.

Variable Speed Pumping

Reducing evaporator flow in proportion to load can reduce system power consumption. Daikin Applied chillers are designed for variable water flow duty provided that the rate of change is less than ten percent of the design flow per minute, and the minimum and maximum flow rates for the evaporator, beginning on [page 45](#), are not exceeded. If flow drops below the minimum allowable, large reductions in heat transfer can occur. If the flow exceeds the maximum rate, excessive pressure drop and tube erosion can occur. For example, if the maximum design flow is 200 gpm and it will be reduced to a flow of 140 gpm, the change in flow is 60 gpm. Ten percent of

200 gpm equals 20 gpm change per minute, or a minimum of three minutes to go from maximum to desired flow.

Ice Mode

Optional double evaporator insulation is recommended for ice mode operation. The standard controller software will require “ice” set point changes and a digital signal into the controller is required to change to the ice mode and back to standard cooling. See the Field Wiring Diagrams on [page 24](#) and [page 25](#) for the connection location. In ice mode, the unit will operate at full load until the shutoff temperature set point is reached.

Glycol Solutions

The installed glycol level must align with the rated glycol percentage indicated on the submitted chiller technical data sheet. Failure to adhere to the rated glycol percentage may result in unit damage and loss of unit warranty

Test fluid with a clean, accurate glycol solution hydrometer (similar to that found in service stations) or refractometer to determine the freezing point. On glycol applications, the supplier normally recommends that a minimum of 25% solution by weight be used for protection against corrosion or that additional inhibitors should be employed.

⚠ CAUTION

Do not use automotive grade antifreeze. Industrial grade glycols must be used. Automotive antifreeze contains inhibitors that will cause plating on the copper tubes within the chiller evaporator. The type and handling of glycol used must be consistent with local codes.

Performance Adjustment Factors

AWV chillers are designed to operate with leaving antifreeze solution temperatures per software range limits. Consult the local Daikin Applied sales office for performance outside these temperatures. Leaving chilled fluid temperatures below 40°F (4.4°C) result in evaporating temperatures at or below the freezing point of water and a glycol solution is required. MicroTech® III control inhibits compressor unloading at leaving fluid temperatures below 25°F (-3.9°C).

Low fluid temperatures or high equipment room humidity for remote evaporators may require optional double evaporator insulation. The system designer should determine its necessity. The use of glycol will reduce unit performance depending on its concentration and should be considered during initial system design.

Figure 39: Integrated Waterside Economizer Option - Representative Model



Integrated Waterside Economizer

Pathfinder Model AWW chillers with an integrated system of waterside economizer coils may be able to satisfy 100% of cooling load without starting a compressor or may run in full mechanical operating mode. Figure 43 illustrates mechanical cooling only mode which would be necessary for high ambient temperatures. Cooling from the integrated waterside economizer (IWSE) coils, Figure 42, is possible when the outdoor air temperature is colder than the fluid temperature requirements. The minimum operating ambient is -20°F (-28.9°C).

The unit controller automatically adjusts two 2-way control valves to bring the IWSE coils in or out of the loop. Bypassing the IWSE coils during mechanical operation only mode avoids the additional pressure drop from the economizer coils.

Hybrid cooling mode operation further maximizes the efficiency of the system by rejecting some heat to the IWSE coils before sending the fluid to the evaporator. The mechanical cooling loop will further cool the fluid to the required setpoint but will use much less energy. Figure 40 shows how the two loops work together in hybrid cooling mode.

Figure 40: Hybrid Cooling Mode Operation

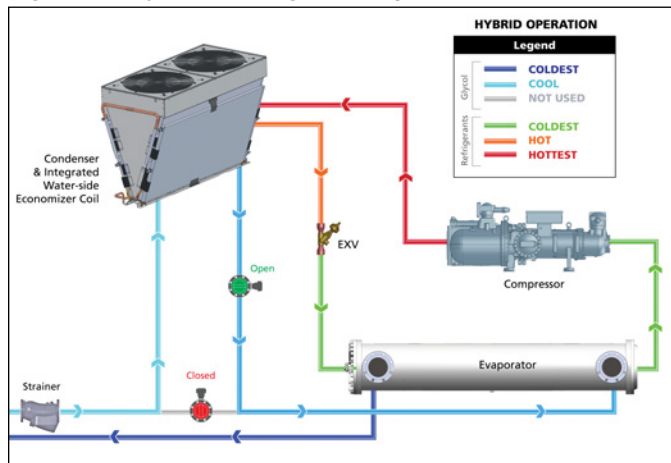

Waterside Economizer Operating Guidelines

1. **Fluid used in IWSE systems must contain glycol.**
The system glycol percentage must be high enough to avoid **burst** conditions at the lowest possible ambient temperature of the installed location, regardless of whether the unit is operating or turned off at that minimum temperature. The chiller fluid loop is required to be protected against **burst** conditions at least 5°F below minimum operating and non-operating ambient temperatures. It is recommended to protect the system against **freeze** conditions 5°F below minimum operating and non-operating ambient temperatures. Failure to ensure adequate glycol freeze protection may result in damage of the water-side economizer coils and coolant leakage from the system.
2. If the chiller is hydraulically isolated, some method of pressure relief must be added to the chiller side fluid loop such as a relief valve or expansion tank; see Figure 41 for connection port. Daikin supplied relief valve kit provides relief valve with ½" female NPT connection and allows for customer to pipe to blowdown tank or other receptacle as may be required by local building codes. The system must not have quick-acting valves or other sources of surge pressure in the fluid loop.
3. Maximum flow rates must be observed to protect IWSE coils and piping; see [Pressure Drop Data on page 45](#).
4. A strainer for the glycol system must meet the requirements of [Inlet Strainer Guidelines on page 18](#).
5. Inhibitors for steel, copper, brass, and aluminum must be included for all closed water loop systems. Some glycols include inhibitors and should be considered when commissioning the water system. Also, all chemicals and additives must be compatible with polypropylene pipe.
6. The glycol system should include a biocide to protect the system against biological growth. The biocide should be non-ionic, non-foaming, and non-oxidizing.

Figure 41: Connection Ports on IWSE Piping

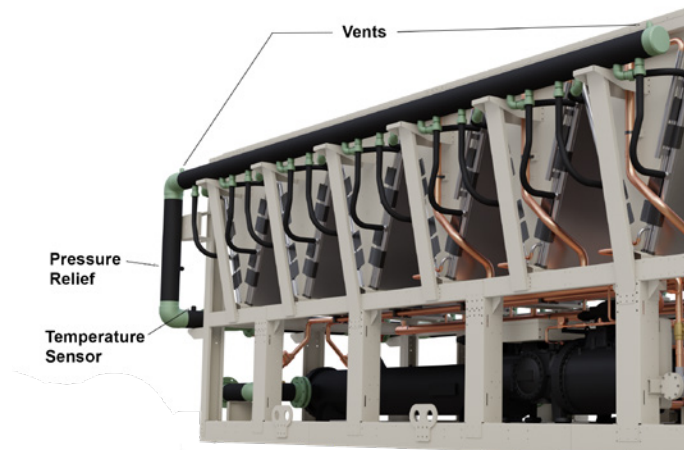

Figure 42: Integrated Waterside Economizer Operation

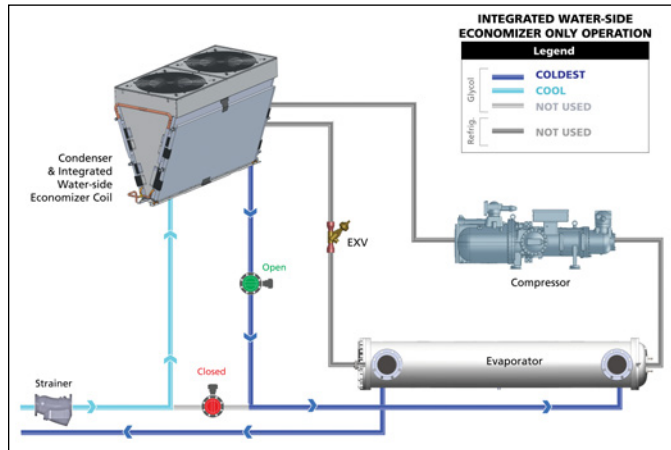
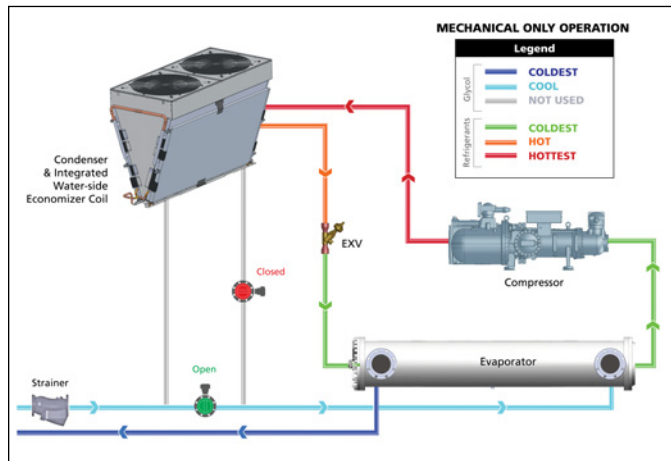

Figure 43: Mechanical Cooling Operation Only



Electrical Connections

Pathfinder® units can be ordered with either standard multi-point power or optional single point power connections and with various disconnect and circuit breaker options. Power wiring connections to the chiller may be done with either copper or aluminum wiring. All wiring must be done in accordance with applicable local and national codes, including NECA/AA 10402012, Standard for Installing Aluminum Building Wire and Cable (ANSI). Wiring within the unit is sized in accordance with the NEC®. Refer to the unit nameplate and the unit selection report for the correct electrical ratings.

⚠ DANGER

Qualified and licensed electricians must perform wiring. Disconnect, lockout, and tag all electrical power sources to the unit before servicing the compressor and/or removing refrigerant. An electrical shock hazard exists that can cause severe injury or death.

The field power wiring required varies depending on unit model. See [page 24](#) and [page 25](#) for wiring information. These wiring diagrams are also provided with the chiller.

NOTE: Wiring, fuse, and wire size must be in accordance with the NEC®. The voltage to these units must be within ±10% of nameplate voltage (415V units must have voltage within -13% and +6% of nameplate voltage) and the voltage unbalance between phases must not exceed 2%. Since a 2% voltage unbalance will cause a current unbalance of 6 to 10 times the voltage unbalance per the NEMA MG-1 Standard, it is most important that the unbalance between phases be kept at a minimum.

⚠ CAUTION

Do not use power factor correction capacitors with AWW chillers. Doing so can cause harmful electrical resonance in the system. Correction capacitors are not necessary since VFDs inherently maintain high power factors.

Table 3: SCCR Ratings (kAmps)

| Voltage/Hz | Standard Short Circuit Panel Rating | High Short Circuit Panel Rating |
|------------|-------------------------------------|---------------------------------|
| 380/60 | 10kA | 65kA |
| 460/60 | 10kA | 65kA |
| 575/60 | 5kA | 25kA |
| 400/50 | 10kA | 65kA |

Field-supplied disconnect switches are required if not factory-supplied with the unit. Disconnecting means are addressed by Article 440 of the NEC®, which requires “disconnecting means capable of disconnecting air conditioning and refrigerating equipment including motor-compressors, and controllers from the circuit feeder.” Select and locate the disconnect switch per the NEC® guidelines.

Terminals are provided in a unit control panel for optional field hookup of the control circuit to a separate fused 115-volt power supply in lieu of the standard factory installed control transformer.

Use with On-Site Generators

Switching from site grid power to generator power and vice versa requires that the chiller must either be powered down or the power must be off for more than five seconds to avoid sending out of phase voltage to the chiller. A properly installed, fully synchronized Automatic Transfer Switch must be used to transfer power if the chiller is running under load.

Generator Sizing

⚠ WARNING

Generator must be sized by an electrical engineer familiar with generator applications.

Transfer Back to Grid Power

Proper transfer from stand-by generator power back to grid power is essential to avoid chiller damage and must be used to ensure proper function of the unit.

⚠ WARNING

Stop the chiller before transferring supply power from the generator back to the utility power grid. Transferring power while the chiller is running can cause severe chiller damage.

The necessary procedure for reconnecting power from the generator back to the utility grid is as follows:

1. Set the generator to always run five minutes longer than the unit start-to-start timer, which can be set from two to sixty minutes, while keeping the chiller powered by the generator until the fully synchronized Automatic Transfer Switch properly hands over chiller power from the site.
2. Configure the transfer switch provided with the generator to automatically shut down the chiller before transfer is made. The automatic shut-off function can be accomplished through a BAS interface or with the "remote on/off" wiring connection shown in the field wiring diagrams.

A start signal can be given anytime after the stop signal since the start-to-start timer will be in effect. The default timer setting is 5 minutes but adjustable as low as 3 minutes.

Long Term Storage

This information applies to new units being stored waiting for startup or to existing units that may be inoperative for an extended period of time.

The chiller must be stored in a dry location and protected from any damage or sources of corrosion. A Daikin Applied service representative must perform an inspection and leak test of the unit on a minimum quarterly schedule, to be paid by the owner or contractor. Daikin Applied will not be responsible for any refrigerant loss during the storage time or for repairs to the unit during the period of storage, or while moving the unit from the original location to a storage facility and back to any new installation location. If there is concern about the possibilities of damage and loss of charge during storage, the customer can have the charge removed and stored in recovery cylinders.

⚠ CAUTION

If the temperature of where the chiller is located is expected to exceed 130°F (54.4°C), then the refrigerant must be removed.

For additional tasks required, contact a Daikin Applied service representative.

Figure 44: Field Wiring Diagram - Single Point Power

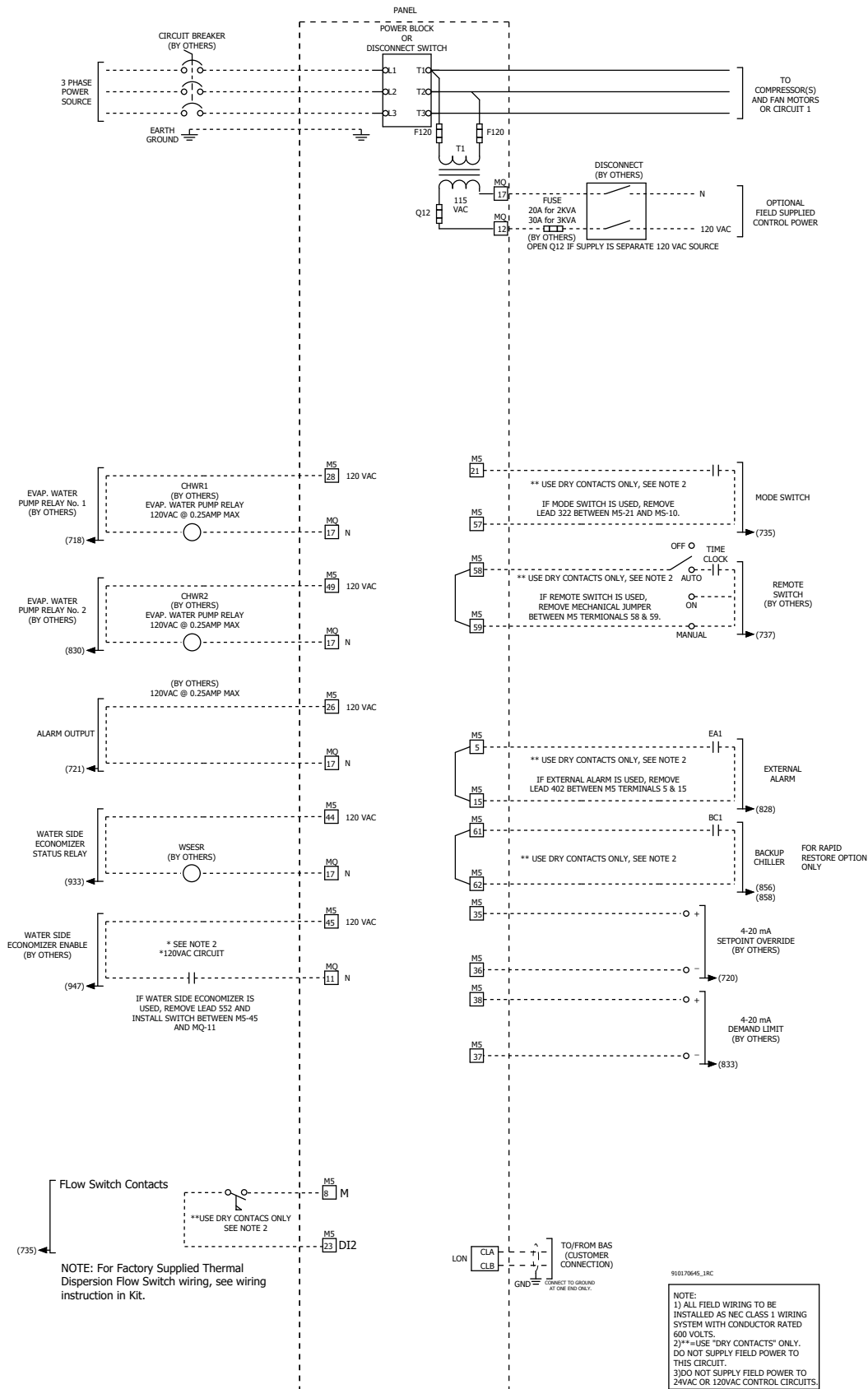
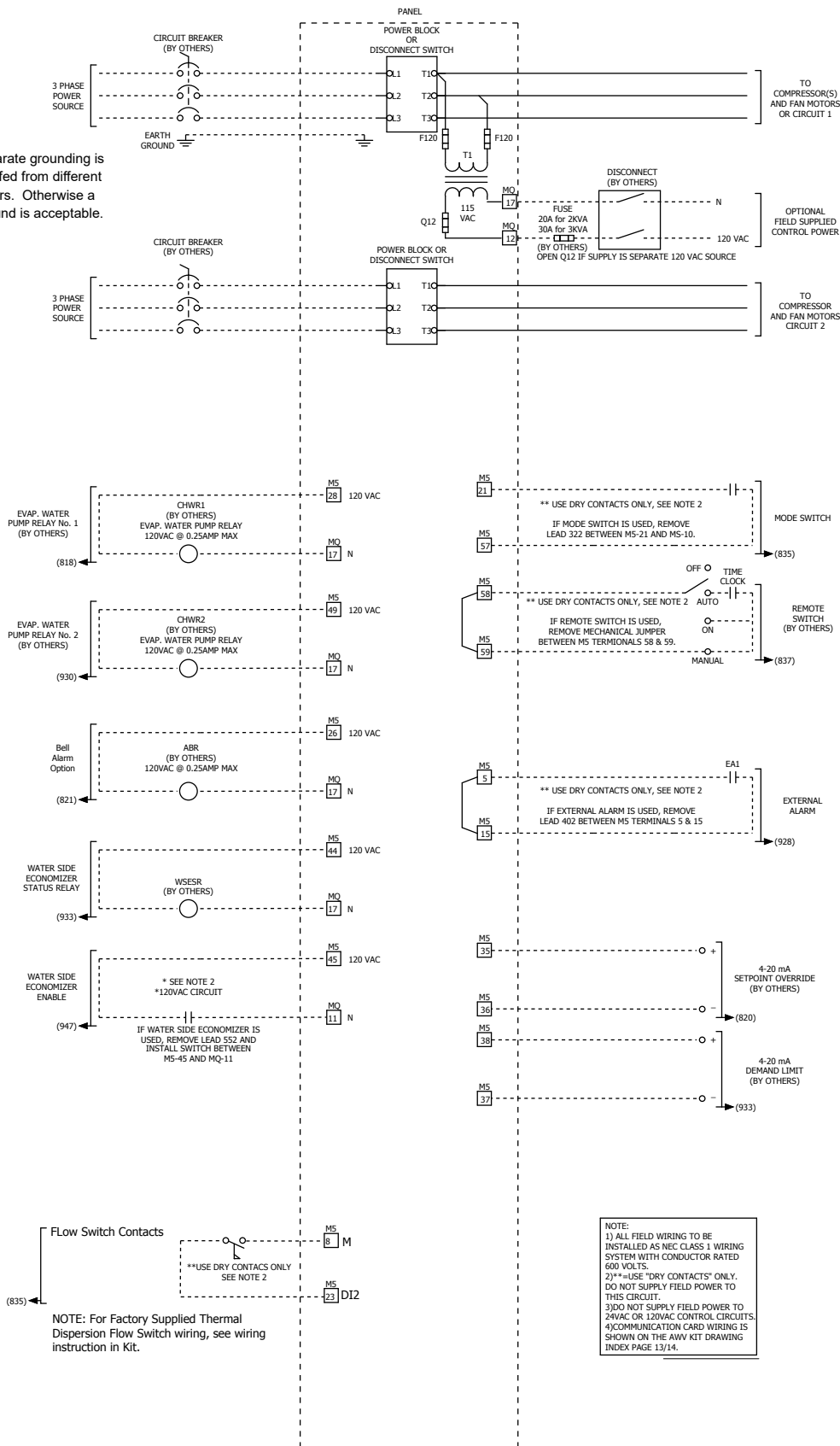

Figure 45: Field Wiring Diagram - Multiple Point Power

Note: Separate grounding is required if fed from different transformers. Otherwise a single ground is acceptable.



NOTE:
 1) ALL FIELD WIRING TO BE INSTALLED AS NEC CLASS 1 WIRING SYSTEM WITH CONDUCTOR RATED 600 VOLTS.
 2) **USE "DRY CONTACTS" ONLY. DO NOT SUPPLY FIELD POWER TO THIS CIRCUIT.
 3) DO NOT SUPPLY FIELD POWER TO 24VAC OR 120VAC CONTROL CIRCUITS.
 4) COMMUNICATION CARD WIRING IS SHOWN ON THE AWW KIT DRAWING INDEX PAGE 13/14.

Figure 46: Representative Refrigerant Diagram - Packaged Unit With Shell & Tube Evaporator Without Optional Economizer

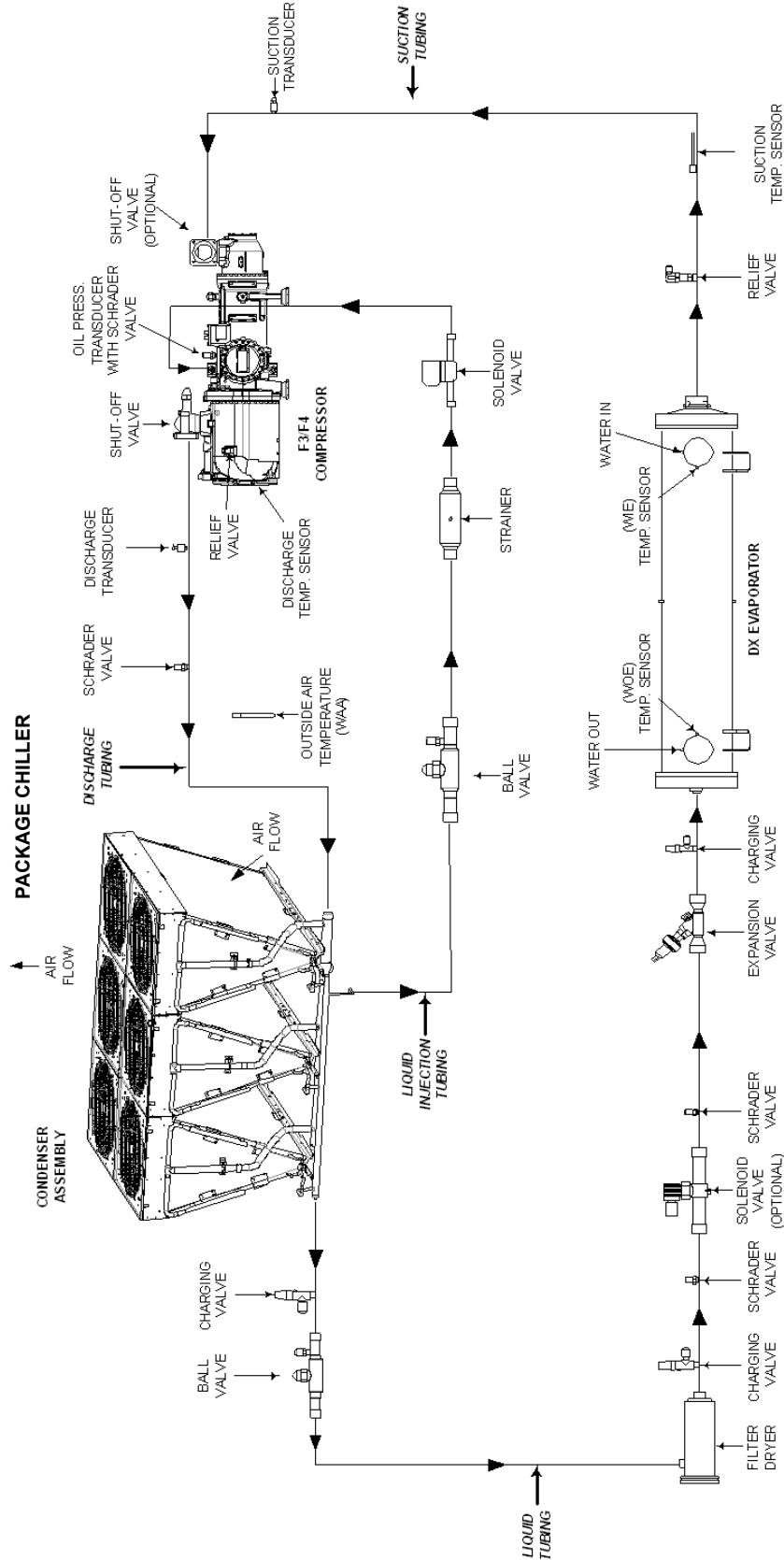

NOTE:
PIPING SHOWN FOR ONE SYSTEM OF UNIT.
UNIT HAS TWO INDEPENDANT SYSTEMS.

Figure 47: Representative Refrigerant Diagram - Packaged Unit With Shell & Tube Evaporator With Optional Economizer

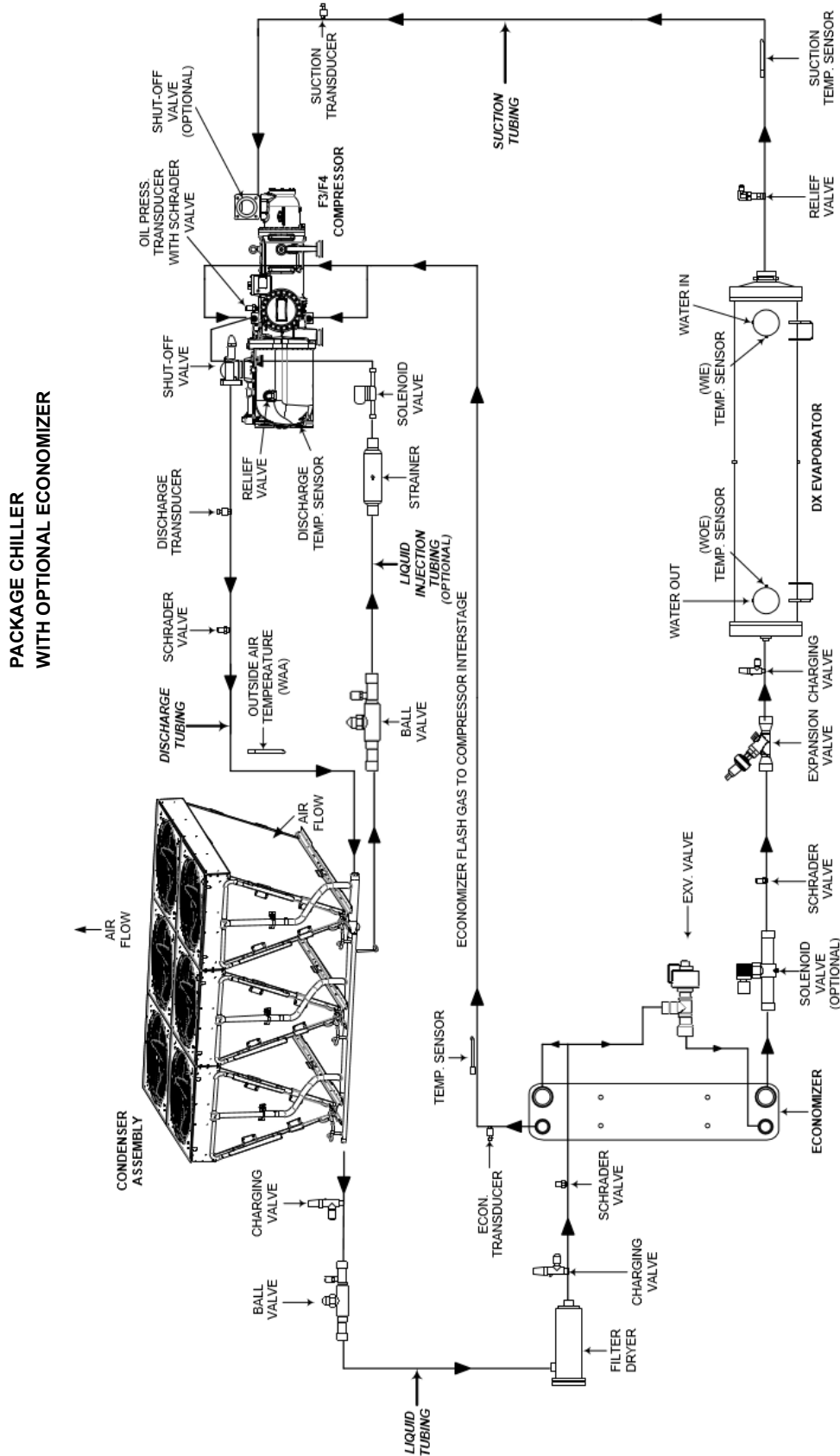

Figure 48: Representative Refrigerant Diagram - Packaged Unit With Braze Plate Evaporator Without Optional Economizer

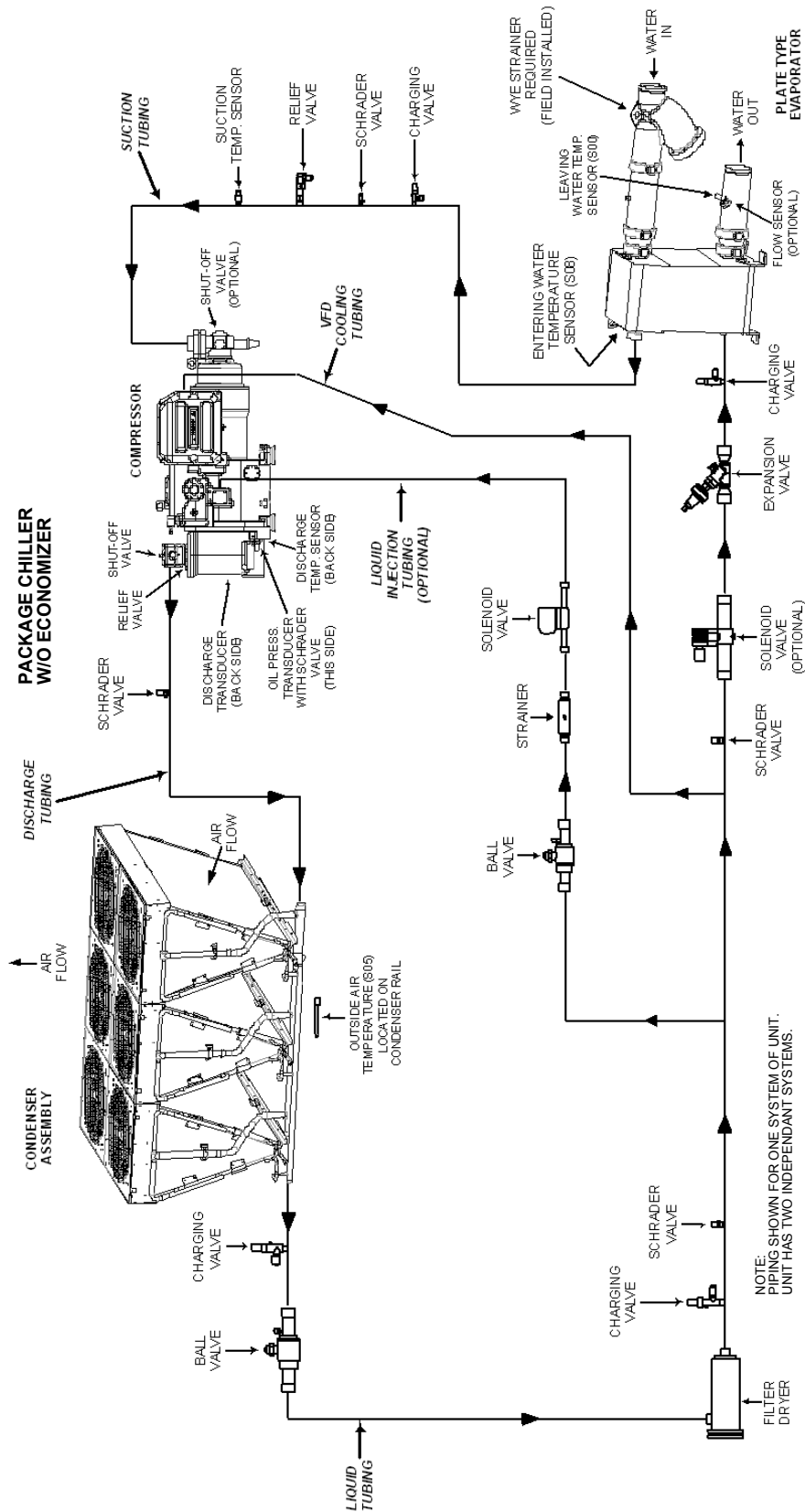

Figure 49: Representative Refrigerant Diagram - Packaged Unit With Braze Plate Evaporator With Optional Economizer

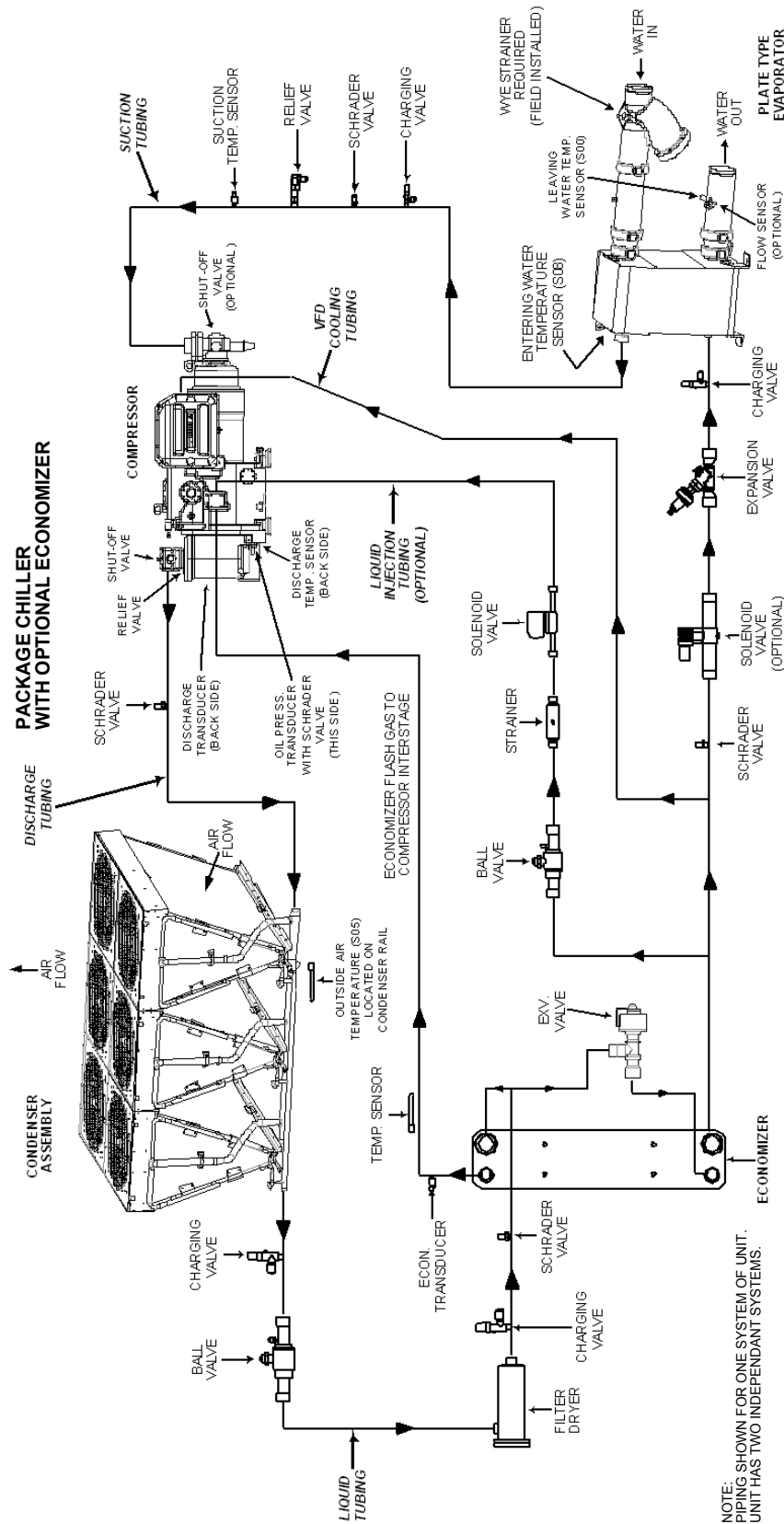
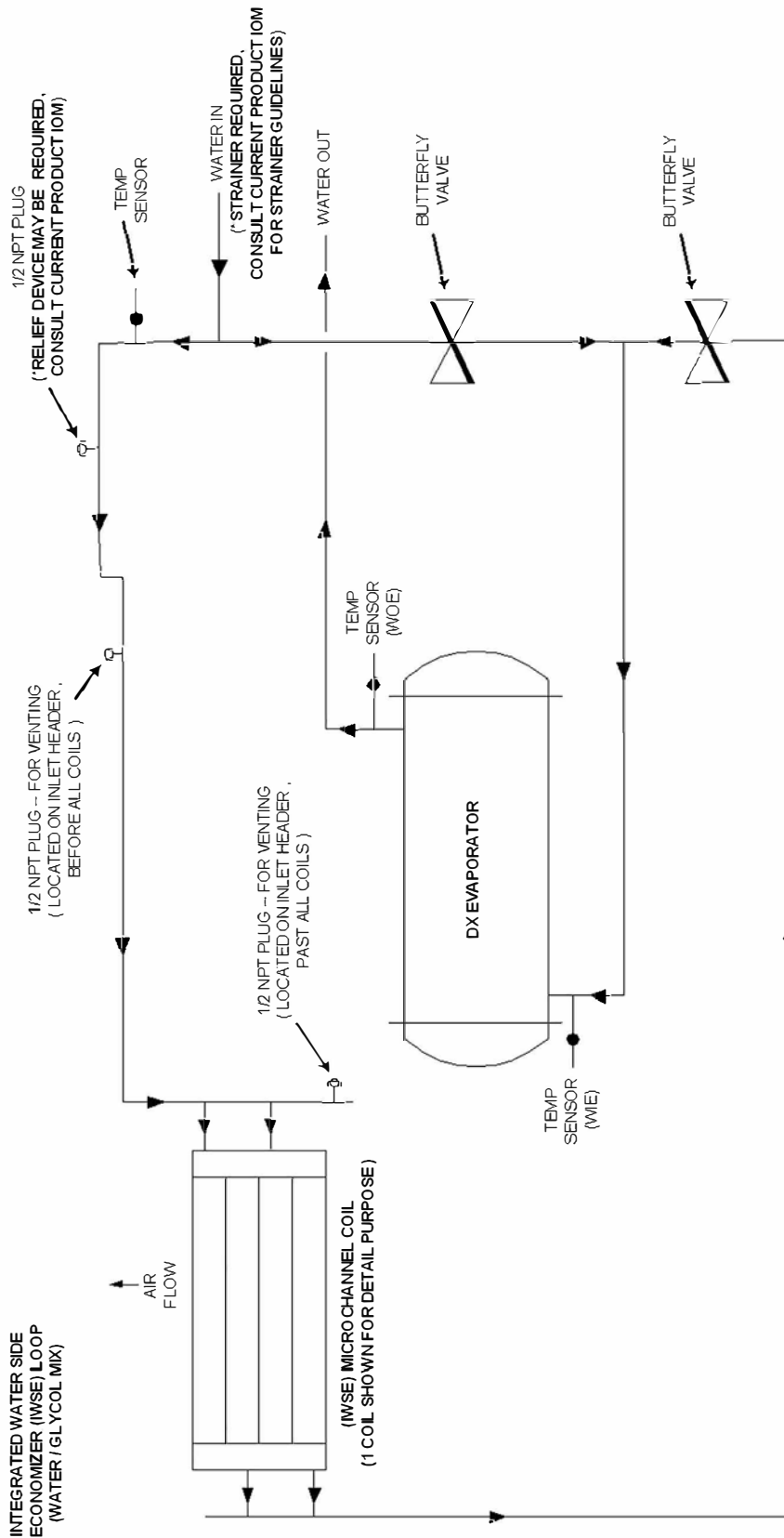

Figure 50: Representative Refrigerant Diagram - Packaged Unit With Optional Integrated Waterside Economizer



Shipment Method

AWV chillers with remote evaporators ship in three pieces.

- Outdoor condensing unit
- Remote evaporator
- Refrigerant specialties kit with the unit has the following components for field installation:
 - Filter-drier housing and cores for field piping
 - Sight glass
 - Electronic expansion valve
 - Solenoid valve
 - Evaporator vent and drain shutoff valves - waterside
 - Charging valve (on non-economizer models)
 - Suction coupling and flange to attachment evaporator
 - Schrader valve
 - Liquid/saturated coupling and flange to evaporator

Performance Data

AWV performance data is available from the current version of Daikin Sales Tools or the local sales office. There is a derate to the performance of an AWV with remote evaporator due to field installed refrigerant line losses, exceeding those found on the packaged arrangement. Use the recommended pipe sizes from Table 5 through Table 9 for design purposes.

Derate Procedure

1. Sketch the liquid and suction piping, including the actual pipe lengths and all fittings.
2. From Table 4, add up the equivalent pressure drop for the fittings in the suction line. Add this value to the actual linear feet of tubing to determine the total equivalent length (TEL) for the piping run.
3. Using Daikin Sales Tools, enter TEL values to determine adjusted unit performance. Consult the Daikin Technical Response Center for all remote evaporator piping installations for review and approval.

Remote Evaporator Refrigerant Piping

Careful design of refrigerant piping is necessary for proper system operation. Refer to the latest version of the ASHRAE Handbook and the Daikin Applied Refrigerant Piping Design Guide, AG31-011, for recommended refrigerant piping practices. Size piping per Table 5 to Table 9. Design the refrigerant piping to accomplish the following:

1. Assure proper refrigerant feed to the evaporator.
2. Provide practical and economical refrigerant line sizes without excess pressure drop.
3. Maintain uniform oil return to the compressor under all load conditions.
4. Keep the refrigerant suction line pressure drop to a maximum of 2°F in saturated temperature equivalent.
5. The velocity of each suction line must be sufficient to return oil at 25% of the circuit rating for the application.
6. When facing the unit control box, the left-hand compressor is circuit #1, and the right-hand is circuit #2.

7. The condenser cannot be used for refrigerant charge isolation for service. The circuit charge will need to be recovered for major service events.



IMPORTANT NOTE

Service Form SF99006 (current version available from the local sales office) must be submitted to Daikin Technical Response Center and reviewed at least two weeks prior to beginning piping installation.

The following applies to all size units:

- New refrigerant piping must be used for all equipment installations. Refrigerant piping must be properly sized for the circuit capacity and unit refrigerant.
- Piping system must be brazed if copper or welded if steel and have the proper lay out with all required components.
- Copper (Type L) piping is recommended; carbon steel piping is allowed (see Table 8). Piping must be installed per industry standards and local codes. Any welded pipe requires a replaceable suction line filter at chiller connect point.
- Measured actual pipe length cannot exceed 200 feet.
- Maximum total equivalent length (TEL) cannot exceed 300 feet (75 feet for vertical suction lines). The evaporator cannot be located more than 20 feet above or 30 feet below the outdoor unit.
- Suction line connection at unit = 4 1/8-inch OD each.
- Underground refrigerant piping is not permitted.
- Field piping must include adequate service taps for checking filter-drier, subcooling, and superheat.
- Insulate complete suction lines. Liquid lines may be insulated to prevent collection of condensation or loss of subcooling if required.
- Ensure the braze rod used is appropriate for the materials being joined.

Table 4: Fitting Losses Equivalent Feet of Pipe

| Line Size In. OD | Angle Valve | Globe Valve | 90-Degree Std. Radius Elbow | 90-Degree Long Radius Elbow |
|------------------|-------------|-------------|-----------------------------|-----------------------------|
| 2 5/8 | 29.0 | 69.0 | 6.0 | 4.1 |
| 3 1/8 | 35.0 | 84.0 | 7.5 | 5.0 |
| 3 5/8 | 41.0 | 100.0 | 9.0 | 5.9 |
| 4 1/8 | 47.0 | 120.0 | 10.0 | 6.7 |
| 5 1/8 | 58.0 | 140.0 | 13.0 | 8.2 |
| 6 1/8 | 70.0 | 170.0 | 16.0 | 10.0 |
| 6 Steel | 70.0 | 170.0 | 16.0 | 10.0 |

SOURCE: ASHRAE 2014 Handbook Refrigeration

NOTE: TEL values for the filter-drier and solenoid valve are already included and should not be added to the liquid line drop.

Remote Evaporator Field Wiring Notes:

1. The 110-V liquid line solenoid valves (LSV) have to be wired back to the outdoor unit. All the conduit and wiring is to be field supplied (14 gauge, red and white wires, 3/8" conduit with straight and 90 degree fittings). If additional length is required, use 14 gauge wire up to a maximum of an additional 100 feet. A din connector

is supplied with refrigerant specialties kits. Field to wire directly into compressor terminal box terminal block:

- **Compressor #1:** (LSV-1) wire 740-1A (red) wires into compressor #1 terminal box terminal block at TB1-2-9. Wire 740-1B (white) wires to TB1-2-10.
 - **Compressor #2:** (LSV-2) wire 740-2A (red) wires into compressor #2 terminal box terminal block at TB2-2-9. Wire 740-2B (white) wires to TB2-2-10.
2. Two evaporator water temperature sensors with 100 feet of cable coiled up and attached to the unit base for extension to the evaporator and insertion in fittings located on the side of the inlet and outlet nozzles.
 3. One suction line refrigerant temperature sensor per circuit with 100 feet of cable coiled up and attached to the unit base for extension to the evaporator.
 4. One suction line pressure transducer per circuit with 100 feet of cable coiled up and attached to the unit base for extension to the evaporator.
 5. The electronic expansion valve has a 30 foot long cable attached and can be used when the outdoor unit is less than 30 feet away. For lengths greater than 30 feet but no more than 200 feet, cut the factory supplied 22 AWG cable/wire as close to the M12 connector (connects to the EXV Stepper Motor) as possible to make a splice using 14 AWG Wire Gauge size, reference Figure 49. NOTE: 14 AWG will use Belden part number 83754 or equivalent. For distances greater than 200 feet, 12 AWG wire is recommended (Belden part number 83804 or equivalent).

The inner foil shield and the outer Braid Shield should be grounded as close as possible to the EXV module

in the control cabinet. Use water tight boxes at splice locations that may be exposed to weather. Individual connections must be soldered and shrink wrapped. An outer shrink wrap is also required and should be wrapped with electrical tape to be made more water resistant. The expansion valve wiring cannot run in conduit with other wiring that is over 24 Volts AC.

6. A flow switch must be installed in the leaving chilled water line per manufacturer's instructions and wired to terminals 8 and 23 on terminal block M5 in the chiller control panel. See Unit Field Wiring Diagrams - Figure 44 and Figure 45.
7. Do not reduce the wire lengths of factory wiring, except as specifically noted in item #5.

Piping Layout

Figure 50 shows the piping layout for one of the two refrigerant circuits for AWW units with a remote evaporator with and without the optional economizer circuit. The outdoor unit, the evaporator, and a kit of refrigerant components are shipped as separate pieces for field mounting, wiring, and piping. The suction shutoff valve is standard on remote evaporator units. All components between the "Field Connection Points" should be located as close to the evaporator as possible.

Note: Field insulation of the suction lines and the liquid line on circuits with economizers is required. The outdoor unit will have a refrigerant charge equal to that of a packaged unit pumped down into the condenser. Any additional charge of refrigerant and oil required by the field piping is supplied by the customer. The location and size of the refrigerant connections are shown on dimensional drawings available from a Daikin Applied sales representative.

Figure 49: Remote EXV Field Wiring

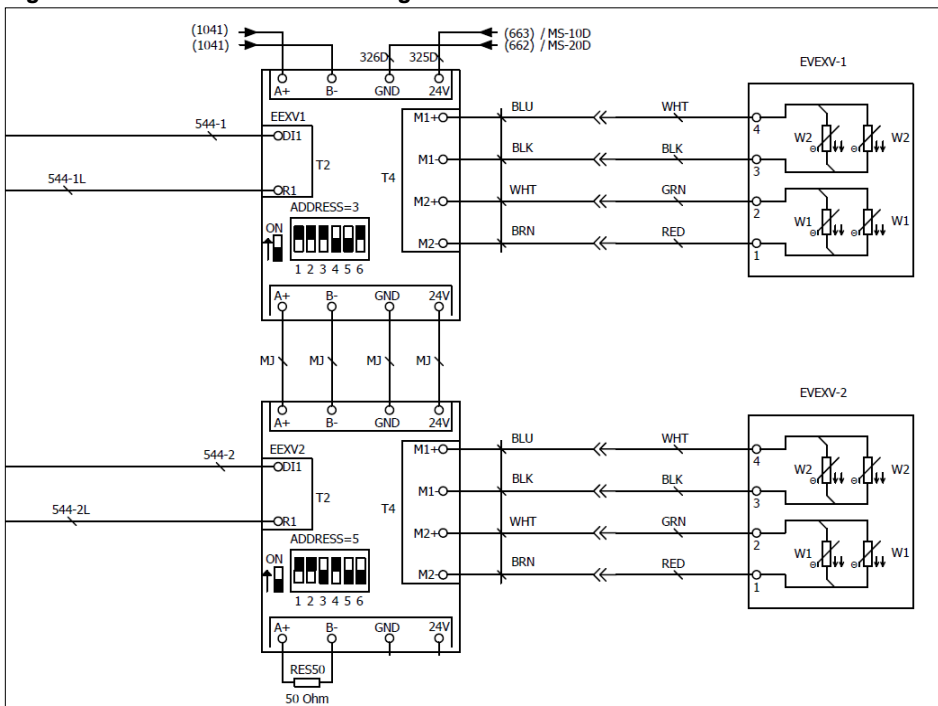

Figure 50: Piping Schematic, Remote Evaporator (One of Two Circuits)

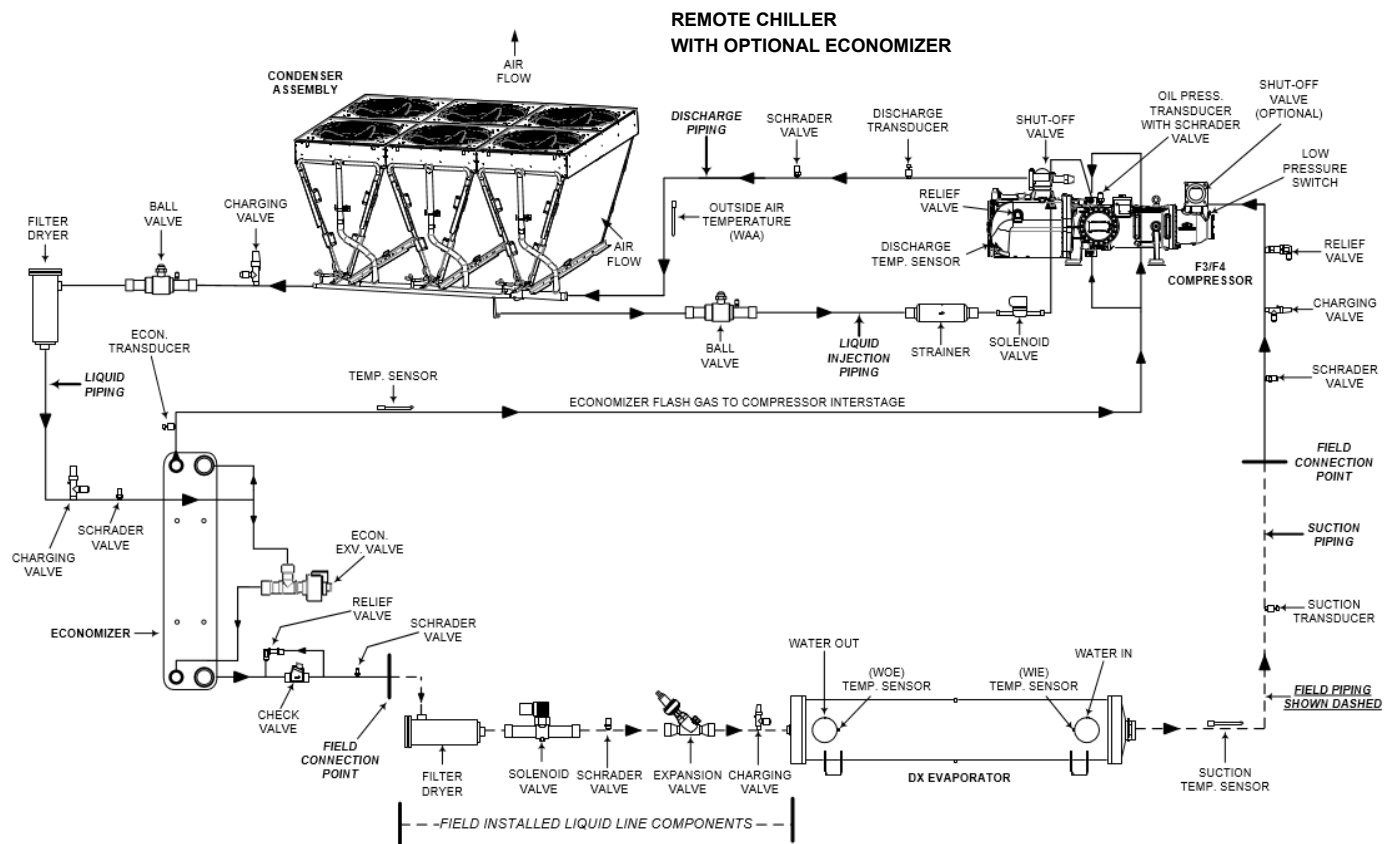
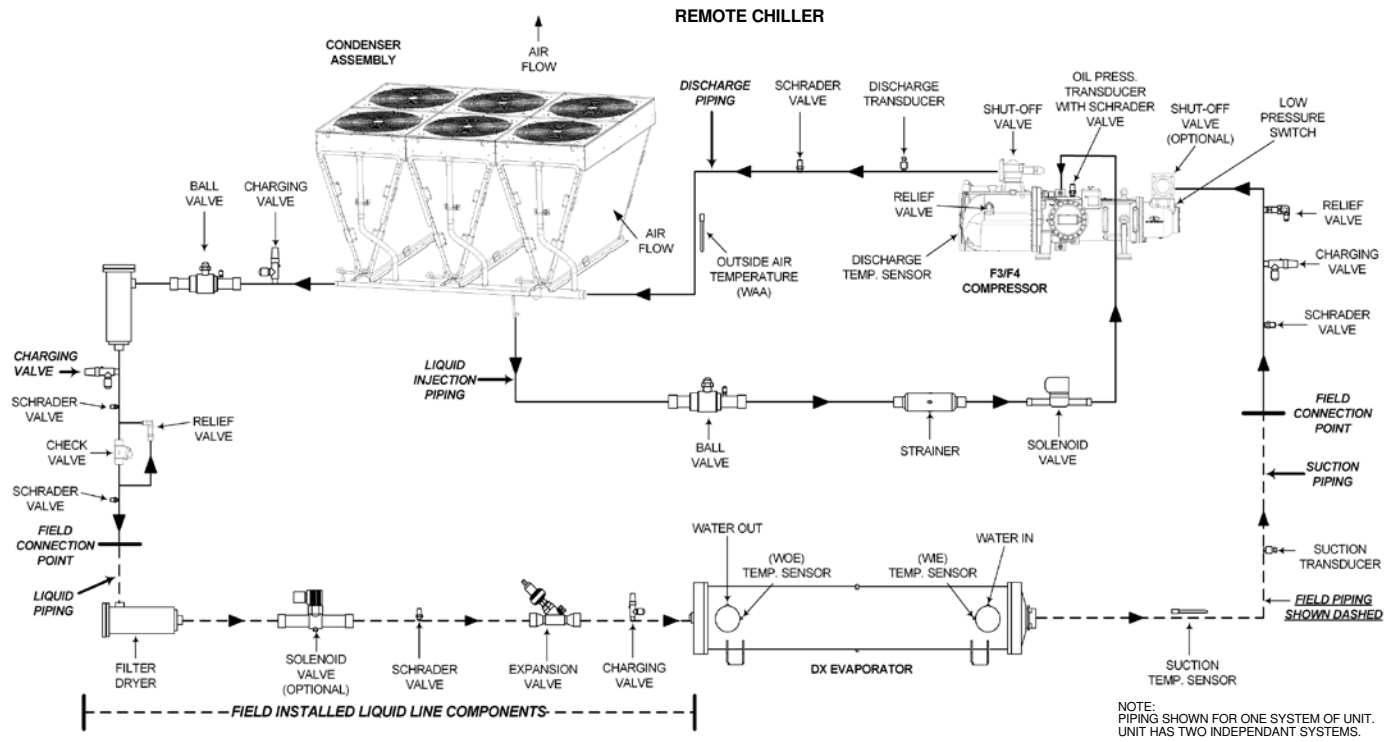

Table 5: Sizing Guidelines for Horizontal or Downflow Suction Lines and Liquid Lines

| Recommended Horizontal or Downflow Suction Line Size | | | |
|--|-------------------------|---------------|----------------------------|
| Nominal Circuit Capacity | Estimated Line TEL (ft) | Line Material | Suction Line Size (Inches) |
| 65 | 50 | Copper | 3 5/8 |
| 90 | 50 | Copper | 3 5/8 |
| 115 | 50 | Copper | 3 5/8 |
| 140 | 50 | Copper | 4 1/8 |
| 165 | 50 | Copper | 4 1/8 |
| 190 | 50 | Copper | 4 1/8 |
| 215 | 50 | Copper | 5 1/8 |
| 240 | 50 | Copper | 5 1/8 |
| 265 | 50 | Copper | 5 1/8 |
| 65 | 75 | Copper | 3 5/8 |
| 90 | 75 | Copper | 3 5/8 |
| 115 | 75 | Copper | 4 1/8 |
| 140 | 75 | Copper | 4 1/8 |
| 165 | 75 | Copper | 5 1/8 |
| 190 | 75 | Copper | 5 1/8 |
| 215 | 75 | Copper | 5 1/8 |
| 240 | 75 | Copper | 5 1/8 |
| 265 | 75 | Copper | 5 1/8 |
| 65 | 100 | Copper | 3 5/8 |
| 90 | 100 | Copper | 3 5/8 |
| 115 | 100 | Copper | 4 1/8 |
| 140 | 100 | Copper | 5 1/8 |
| 165 | 100 | Copper | 5 1/8 |
| 190 | 100 | Copper | 5 1/8 |
| 215 | 100 | Copper | 5 1/8 |
| 240 | 100 | Copper | 6 1/8 |
| 265 | 100 | Copper | 6 1/8 |
| 65 | 125 | Copper | 3 5/8 |
| 90 | 125 | Copper | 4 1/8 |
| 115 | 125 | Copper | 4 1/8 |
| 140 | 125 | Copper | 5 1/8 |
| 165 | 125 | Copper | 5 1/8 |
| 190 | 125 | Copper | 5 1/8 |
| 215 | 125 | Copper | 6 1/8 |
| 240 | 125 | Copper | 6 1/8 |
| 265 | 125 | Copper | 6 1/8 |

| Recommended Liquid Line Size | | | |
|------------------------------|-------------------------|---------------|---------------------------|
| Nominal Circuit Capacity | Estimated Line TEL (ft) | Line Material | Liquid Line Size (Inches) |
| 65 | 50 | Copper | 1 5/8 |
| 90 | 50 | Copper | 1 5/8 |
| 115 | 50 | Copper | 1 5/8 |
| 140 | 50 | Copper | 1 5/8 |
| 165 | 50 | Copper | 2 1/8 |
| 190 | 50 | Copper | 2 1/8 |
| 215 | 50 | Copper | 2 1/8 |
| 240 | 50 | Copper | 2 1/8 |
| 265 | 50 | Copper | 2 1/8 |
| 65 | 75 | Copper | 1 5/8 |
| 90 | 75 | Copper | 1 5/8 |
| 115 | 75 | Copper | 2 1/8 |
| 140 | 75 | Copper | 2 1/8 |
| 165 | 75 | Copper | 2 1/8 |
| 190 | 75 | Copper | 2 1/8 |
| 215 | 75 | Copper | 2 1/8 |
| 240 | 75 | Copper | 2 1/8 |
| 265 | 75 | Copper | 2 5/8 |
| 65 | 100 | Copper | 1 5/8 |
| 90 | 100 | Copper | 1 5/8 |
| 115 | 100 | Copper | 2 1/8 |
| 140 | 100 | Copper | 2 1/8 |
| 165 | 100 | Copper | 2 1/8 |
| 190 | 100 | Copper | 2 1/8 |
| 215 | 100 | Copper | 2 5/8 |
| 240 | 100 | Copper | 2 5/8 |
| 265 | 100 | Copper | 2 5/8 |
| 65 | 125 | Copper | 1 5/8 |
| 90 | 125 | Copper | 1 5/8 |
| 115 | 125 | Copper | 2 1/8 |
| 140 | 125 | Copper | 2 1/8 |
| 165 | 125 | Copper | 2 1/8 |
| 190 | 125 | Copper | 2 5/8 |
| 215 | 125 | Copper | 2 5/8 |
| 240 | 125 | Copper | 2 5/8 |
| 265 | 125 | Copper | 2 5/8 |

Table 6: Sizing Guidelines for Horizontal or Downflow Suction Lines and Liquid Lines

| Recommended Horizontal or Downflow Suction Line Size | | | |
|--|-------------------------|---------------|----------------------------|
| Nominal Circuit Capacity | Estimated Line TEL (ft) | Line Material | Suction Line Size (Inches) |
| 65 | 150 | Copper | 3 5/8 |
| 90 | 150 | Copper | 4 1/8 |
| 115 | 150 | Copper | 4 1/8 |
| 140 | 150 | Copper | 5 1/8 |
| 165 | 150 | Copper | 5 1/8 |
| 190 | 150 | Copper | 6 1/8 |
| 215 | 150 | Copper | 6 1/8 |
| 240 | 150 | Copper | 6 1/8 |
| 265 | 150 | Copper | 6 1/8 |
| 65 | 175 | Copper | 4 1/8 |
| 90 | 175 | Copper | 4 1/8 |
| 115 | 175 | Copper | 4 1/8 |
| 140 | 175 | Copper | 5 1/8 |
| 165 | 175 | Copper | 5 1/8 |
| 190 | 175 | Copper | 6 1/8 |
| 215 | 175 | Copper | 6 1/8 |
| 240 | 175 | Copper | 6 1/8 |
| 265 | 175 | Copper | 6 1/8 |
| 65 | 200 | Copper | 4 1/8 |
| 90 | 200 | Copper | 4 1/8 |
| 115 | 200 | Copper | 4 1/8 |
| 140 | 200 | Copper | 5 1/8 |
| 165 | 200 | Copper | 5 1/8 |
| 190 | 200 | Copper | 6 1/8 |
| 215 | 200 | Copper | 6 1/8 |
| 240 | 200 | Copper | 6 1/8 |
| 265 | 200 | Copper | 6 1/8 |
| 65 | 225 | Copper | 4 1/8 |
| 90 | 225 | Copper | 4 1/8 |
| 115 | 225 | Copper | 4 1/8 |
| 140 | 225 | Copper | 5 1/8 |
| 165 | 225 | Copper | 5 1/8 |
| 190 | 225 | Copper | 6 1/8 |
| 215 | 225 | Copper | 6 1/8 |
| 240 | 225 | Copper | 6 1/8 |
| 265 | 225 | Copper | 6 1/8 |

| Recommended Liquid Line Size | | | |
|------------------------------|-------------------------|---------------|---------------------------|
| Nominal Circuit Capacity | Estimated Line TEL (ft) | Line Material | Liquid Line Size (Inches) |
| 65 | 150 | Copper | 1 5/8 |
| 90 | 150 | Copper | 2 1/8 |
| 115 | 150 | Copper | 2 1/8 |
| 140 | 150 | Copper | 2 1/8 |
| 165 | 150 | Copper | 2 1/8 |
| 190 | 150 | Copper | 2 5/8 |
| 215 | 150 | Copper | 2 5/8 |
| 240 | 150 | Copper | 2 5/8 |
| 265 | 150 | Copper | 2 5/8 |
| 65 | 175 | Copper | 1 5/8 |
| 90 | 175 | Copper | 2 1/8 |
| 115 | 175 | Copper | 2 1/8 |
| 140 | 175 | Copper | 2 1/8 |
| 165 | 175 | Copper | 2 5/8 |
| 190 | 175 | Copper | 2 5/8 |
| 215 | 175 | Copper | 2 5/8 |
| 240 | 175 | Copper | 2 5/8 |
| 265 | 175 | Copper | 2 5/8 |
| 65 | 200 | Copper | 1 5/8 |
| 90 | 200 | Copper | 2 1/8 |
| 115 | 200 | Copper | 2 1/8 |
| 140 | 200 | Copper | 2 1/8 |
| 165 | 200 | Copper | 2 5/8 |
| 190 | 200 | Copper | 2 5/8 |
| 215 | 200 | Copper | 2 5/8 |
| 240 | 200 | Copper | 2 5/8 |
| 265 | 200 | Copper | 3 1/8 |
| 65 | 225 | Copper | 2 1/8 |
| 90 | 225 | Copper | 2 1/8 |
| 115 | 225 | Copper | 2 1/8 |
| 140 | 225 | Copper | 2 5/8 |
| 165 | 225 | Copper | 2 5/8 |
| 190 | 225 | Copper | 2 5/8 |
| 215 | 225 | Copper | 2 5/8 |
| 240 | 225 | Copper | 3 1/8 |
| 265 | 225 | Copper | 3 1/8 |

Table 7: Sizing Guidelines for Horizontal or Downflow Suction Lines and Liquid Lines

| Recommended Horizontal or Downflow Suction Line Size | | | |
|--|-------------------------|---------------|----------------------------|
| Nominal Circuit Capacity | Estimated Line TEL (ft) | Line Material | Suction Line Size (Inches) |
| 65 | 250 | Copper | 4 1/8 |
| 90 | 250 | Copper | 4 1/8 |
| 115 | 250 | Copper | 4 1/8 |
| 140 | 250 | Copper | 5 1/8 |
| 165 | 250 | Copper | 5 1/8 |
| 190 | 250 | Copper | 6 1/8 |
| 215 | 250 | Copper | 6 1/8 |
| 240 | 250 | Copper | 6 1/8 |
| 265 | 250 | Copper | 6 1/8 |
| 65 | 275 | Copper | 4 1/8 |
| 90 | 275 | Copper | 4 1/8 |
| 115 | 275 | Copper | 4 1/8 |
| 140 | 275 | Copper | 5 1/8 |
| 165 | 275 | Copper | 5 1/8 |
| 190 | 275 | Copper | 6 1/8 |
| 215 | 275 | Copper | 6 1/8 |
| 240 | 275 | Copper | 6 1/8 |
| 265 | 275 | Copper | 6 1/8 |
| 65 | 300 | Copper | 4 1/8 |
| 90 | 300 | Copper | 4 1/8 |
| 115 | 300 | Copper | 4 1/8 |
| 140 | 300 | Copper | 5 1/8 |
| 165 | 300 | Copper | 5 1/8 |
| 190 | 300 | Copper | 6 1/8 |
| 215 | 300 | Copper | 6 1/8 |
| 240 | 300 | Copper | 6 1/8 |
| 265 | 300 | Copper | 6 1/8 |

| Recommended Liquid Line Sizes | | | |
|-------------------------------|-------------------------|---------------|---------------------------|
| Nominal Circuit Capacity | Estimated Line TEL (ft) | Line Material | Liquid Line Size (Inches) |
| 65 | 250 | Copper | 2 1/8 |
| 90 | 250 | Copper | 2 1/8 |
| 115 | 250 | Copper | 2 1/8 |
| 140 | 250 | Copper | 2 5/8 |
| 165 | 250 | Copper | 2 5/8 |
| 190 | 250 | Copper | 2 5/8 |
| 215 | 250 | Copper | 2 5/8 |
| 240 | 250 | Copper | 3 1/8 |
| 265 | 250 | Copper | 3 1/8 |
| 65 | 275 | Copper | 2 1/8 |
| 90 | 275 | Copper | 2 1/8 |
| 115 | 275 | Copper | 2 1/8 |
| 140 | 275 | Copper | 2 5/8 |
| 165 | 275 | Copper | 2 5/8 |
| 190 | 275 | Copper | 2 5/8 |
| 215 | 275 | Copper | 3 1/8 |
| 240 | 275 | Copper | 3 1/8 |
| 265 | 275 | Copper | 3 1/8 |
| 65 | 300 | Copper | 2 1/8 |
| 90 | 300 | Copper | 2 1/8 |
| 115 | 300 | Copper | 2 1/8 |
| 140 | 300 | Copper | 2 5/8 |
| 165 | 300 | Copper | 2 5/8 |
| 190 | 300 | Copper | 2 5/8 |
| 215 | 300 | Copper | 3 1/8 |
| 240 | 300 | Copper | 3 1/8 |
| 265 | 300 | Copper | 3 1/8 |

Table 8: Alternate Sizing Guidelines for Horizontal or Downflow Suction Lines - Steel

| Recommended Horizontal or Downflow Suction Line Size | | | |
|--|-------------------------|---------------|----------------------------|
| Nominal Circuit Capacity | Estimated Line TEL (ft) | Line Material | Suction Line Size (Inches) |
| 240 | 100 | Steel | 6 |
| 265 | 100 | Steel | 6 |
| 215 | 125 | Steel | 6 |
| 240 | 125 | Steel | 6 |
| 265 | 125 | Steel | 6 |
| 190 | 150 | Steel | 6 |
| 215 | 150 | Steel | 6 |
| 240 | 150 | Steel | 6 |
| 265 | 150 | Steel | 6 |
| 190 | 175 | Steel | 6 |
| 215 | 175 | Steel | 6 |
| 240 | 175 | Steel | 6 |
| 265 | 175 | Steel | 6 |
| 190 | 200 | Steel | 6 |
| 215 | 200 | Steel | 6 |
| 240 | 200 | Steel | 6 |
| 265 | 200 | Steel | 6 |
| 190 | 225 | Steel | 6 |
| 215 | 225 | Steel | 6 |
| 240 | 225 | Steel | 6 |
| 265 | 225 | Steel | 6 |
| 190 | 250 | Steel | 6 |
| 215 | 250 | Steel | 6 |
| 240 | 250 | Steel | 6 |
| 265 | 250 | Steel | 6 |
| 190 | 275 | Steel | 6 |
| 215 | 275 | Steel | 6 |
| 240 | 275 | Steel | 6 |
| 265 | 275 | Steel | 6 |
| 190 | 300 | Steel | 6 |
| 215 | 300 | Steel | 6 |
| 240 | 300 | Steel | 6 |
| 265 | 300 | Steel | 6 |

NOTE: FOR STEEL LINES ONLY

For use in horizontal and down flow applications only where the evaporator is at or below the chiller elevation.

Recommend schedule 40 steel pipe.

Carbon steel pipe shall be ASTM Standard A 53 Grade B, Type E (electric resistance welded) or Type S (seamless); or ASTM Standard A 106 Grade B (seamless). Standard A 53 Type F is not permitted.

Refrigeration piping design and fabrication should be in accordance with the applicable sections of ASME B31.5 - Refrigeration Piping and Heat Transfer Components for the steel piping.

Table 9: Sizing Guidelines for Upflow Lines

| Recommended Upflow Suction Line Size | | | |
|--------------------------------------|---------------|----------------------------|-------------------------|
| Nominal Circuit Capacity | Line Material | Suction Line Size (Inches) | Estimated Line TEL (ft) |
| 65 | Copper | 3 5/8 | 50 |
| 90 | Copper | 3 5/8 | 50 |
| 115 | Copper | 3 5/8 | 50 |
| 140 | Copper | 4 1/8 | 50 |
| 165 | Copper | 4 1/8 | 50 |
| 190 | Copper | 5 1/8 | 50 |
| 215 | Copper | 5 1/8 | 50 |
| 240 | Copper | 5 1/8 | 50 |
| 265 | Copper | 5 1/8 | 50 |
| 65 | Copper | 3 5/8 | 75 |
| 90 | Copper | 3 5/8 | 75 |
| 115 | Copper | 3 5/8 | 75 |
| 140 | Copper | 4 1/8 | 75 |
| 165 | Copper | 4 1/8 | 75 |
| 190 | Copper | 5 1/8 | 75 |
| 215 | Copper | 5 1/8 | 75 |
| 240 | Copper | 5 1/8 | 75 |
| 265 | Copper | 5 1/8 | 75 |

Table 10: Evaporator Data for AWW Remote Evaporator Models

| Evaporator Model | Shipping Weight | | Operating Weight | | Water Volume | |
|------------------|-----------------|------|------------------|------|--------------|------|
| | (lb) | (kg) | (lb) | (kg) | (gal) | (L) |
| EV40271010/9 | 1197 | 543 | 1761 | 799 | 67 | 255 |
| EV40271111/7 | 1219 | 553 | 1773 | 804 | 66 | 250 |
| EV40271212/7 | 1239 | 562 | 1770 | 803 | 63 | 240 |
| EV50271414/7 | 1739 | 789 | 2631 | 1193 | 106 | 403 |
| EV50271717/5 | 1819 | 825 | 2648 | 1201 | 99 | 374 |
| EV50391212/11 | 2077 | 942 | 3365 | 1526 | 154 | 582 |
| EV66331515/7 | 2593 | 1176 | 4475 | 2030 | 225 | 851 |
| EV66391414/11 | 2875 | 1304 | 5145 | 2334 | 271 | 1027 |
| EV66391616/9 | 2956 | 1341 | 5157 | 2339 | 263 | 995 |
| EV66391717/7 | 2998 | 1360 | 5164 | 2342 | 259 | 979 |

Figure 51: Evaporator Model EV4027

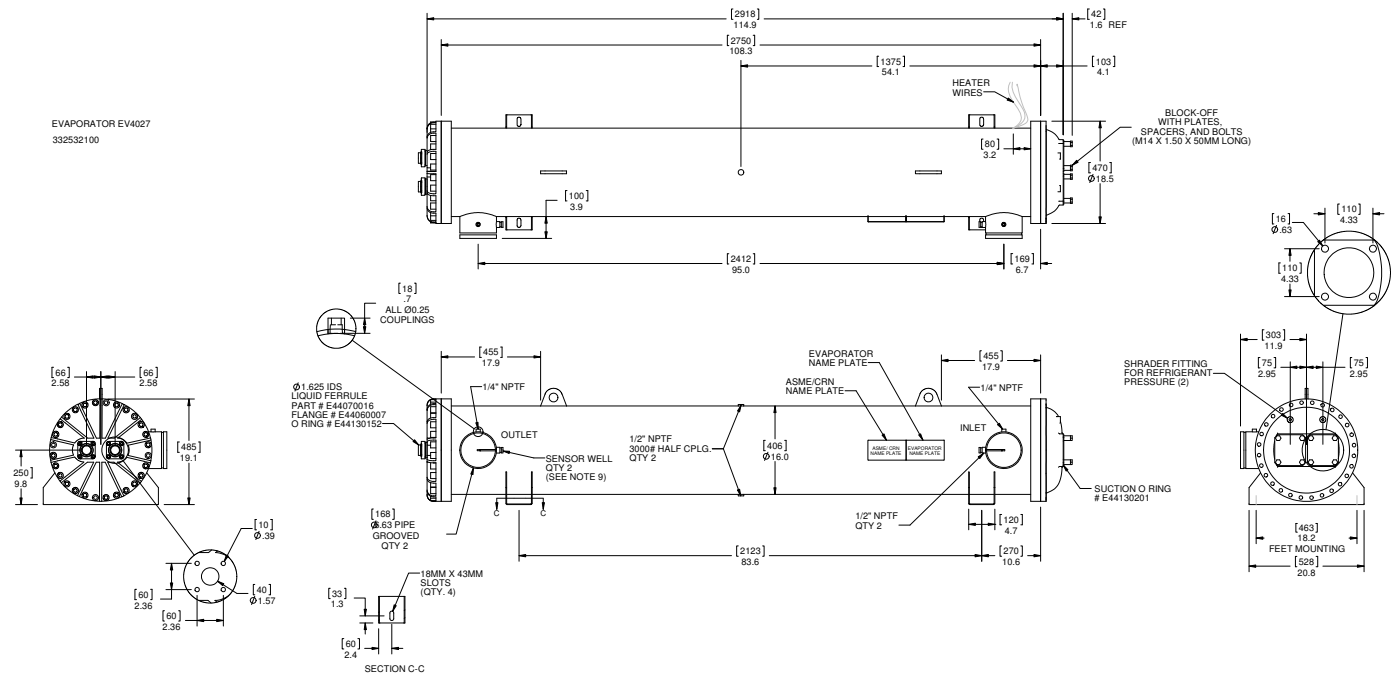

Figure 52: Evaporator Model EV5027

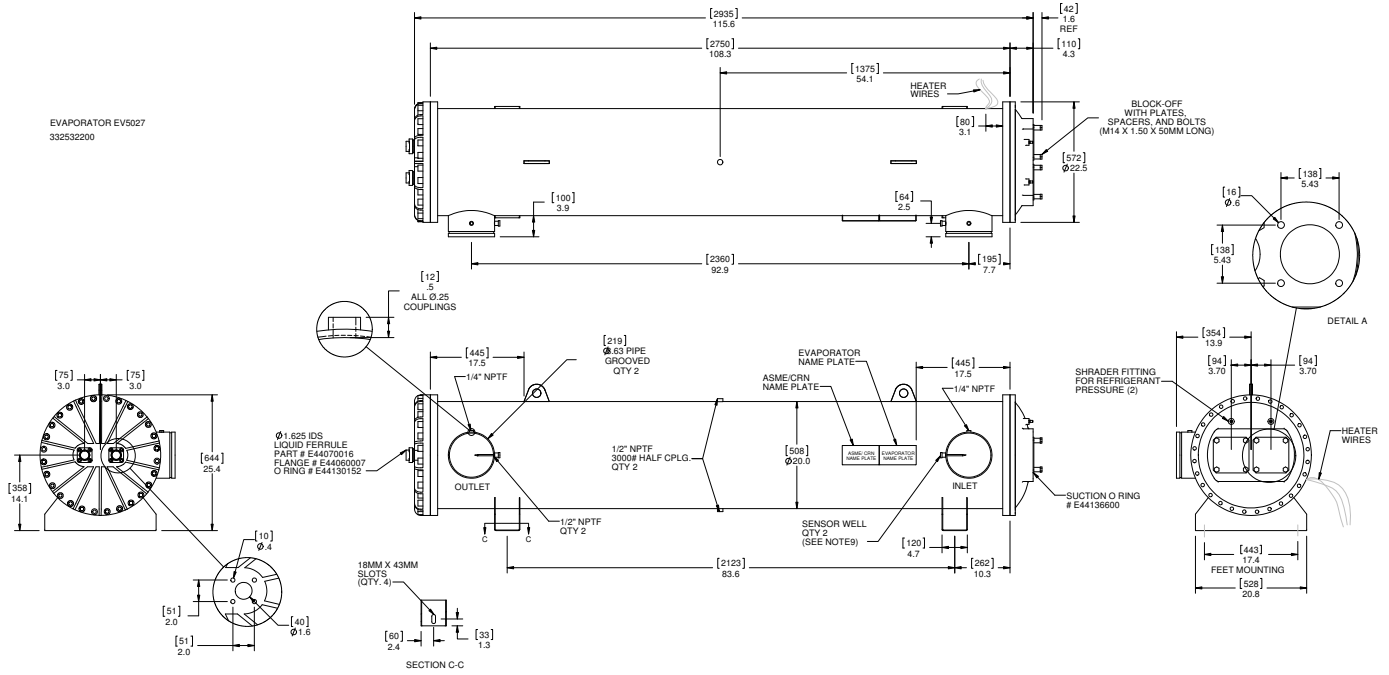

Figure 53: Evaporator Model EV5039

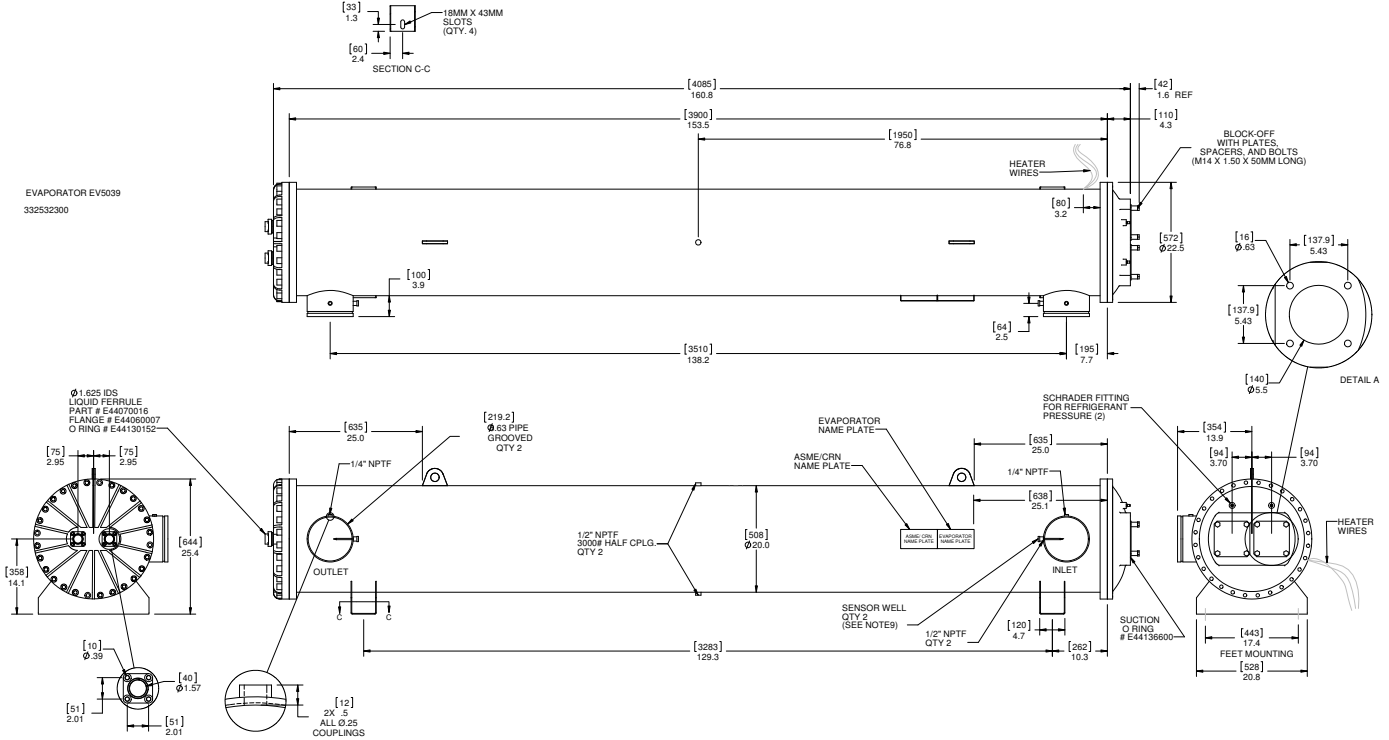

Figure 56: Reference Dimensional Drawing - 08 Fan to 14 Fan Configurations With Brazed Plate Evaporator

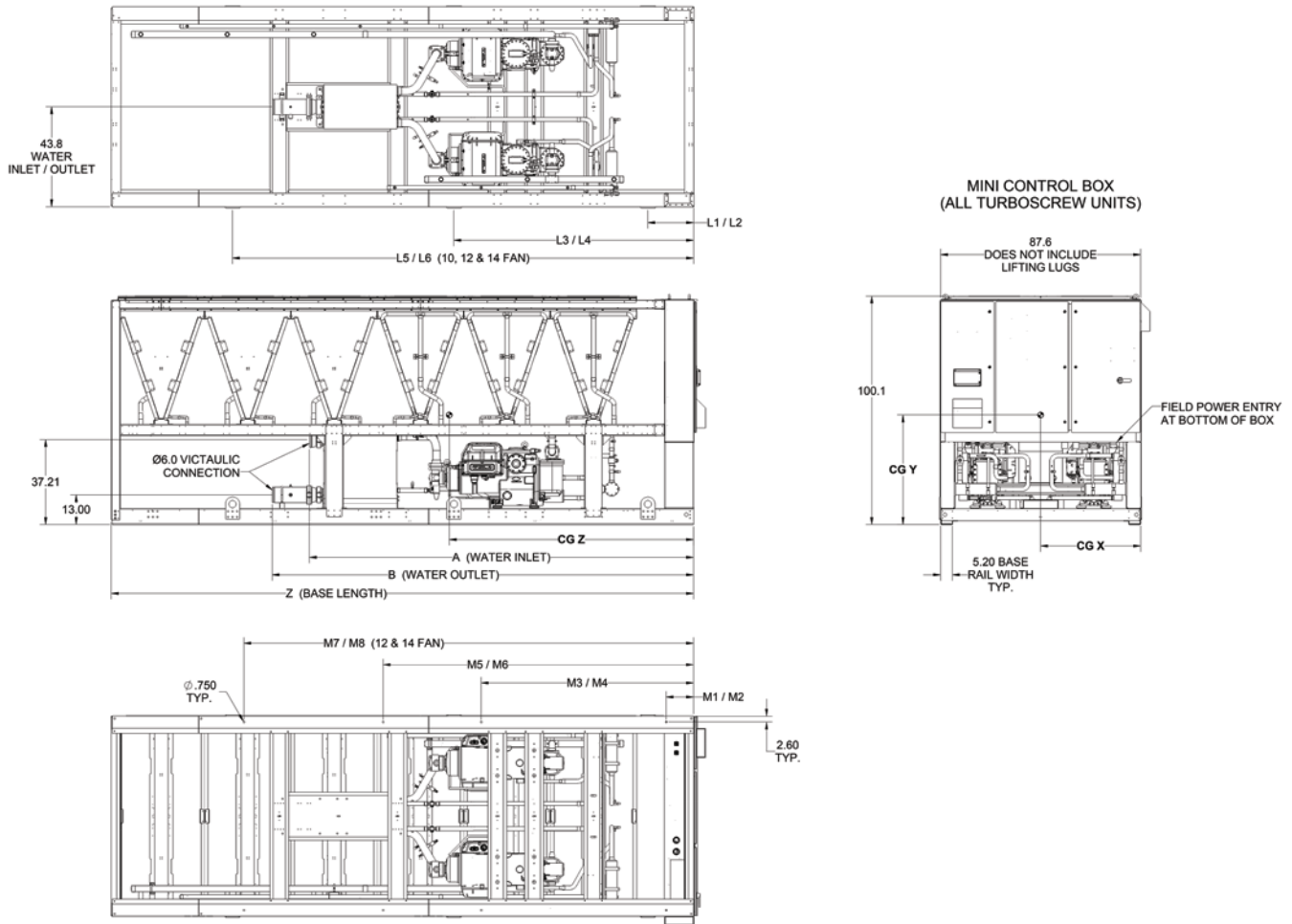

Table 11: Unit Dimensions by Configuration with Brazed Plate Evaporator

| # OF FANS | EVAP | A | B | Z | CG X | CG Y | CG Z | L1 / L2 | L3 / L4 | L5 / L6 | M1 / M2 | M3 / M4 | M5 / M6 | M7 / M8 | | | | | | | | |
|-----------|---------------|-------|-------|-------|--------------------------------------|------|------|---------|---------|---------|---------|---------|---------|---------|--|--|--|-------|-------|--|-------|-------|
| 8 | ACH1000DQ-166 | 152.8 | 169.1 | 179.3 | Refer to Submitted As-Built Drawings | CG Y | CG Z | 20 | 148 | N/A | 12 | 93 | 160 | N/A | | | | | | | | |
| | ACH1000DQ-206 | 156.5 | 172.8 | | | | | | | | | | | | | | | | | | | |
| 10 | ACH1000DQ-206 | 156.5 | 172.8 | 217.2 | | | | | | | | | | | | | | 105 | 169 | | 190 | |
| | ACH1000DQ-250 | 160.7 | 177 | | | | | | | | | | | | | | | | | | | |
| | ACH1000DQ-330 | 168.3 | 184.6 | | | | | | | | | | | | | | | | | | | |
| 12 | ACH1000DQ-206 | 156.5 | 172.8 | 255.1 | | | | | | | | | | | | | | 105 | 202 | | 136 | 197 |
| | ACH1000DQ-250 | 160.7 | 177 | | | | | | | | | | | | | | | | | | | |
| | ACH1000DQ-330 | 168.3 | 184.6 | | | | | | | | | | | | | | | | | | | |
| 14 | ACH1000DQ-250 | 160.7 | 177.0 | 293.0 | | | | | | | | | | | | | | 139.0 | 228.0 | | 136.0 | 250.0 |
| | ACH1000DQ-330 | 168.3 | 184.6 | | | | | | | | | | | | | | | | | | | |

Figure 57: Reference Dimensional Drawing - 12 Fan and 14 Fan Configurations with Shell and Tube Evaporator

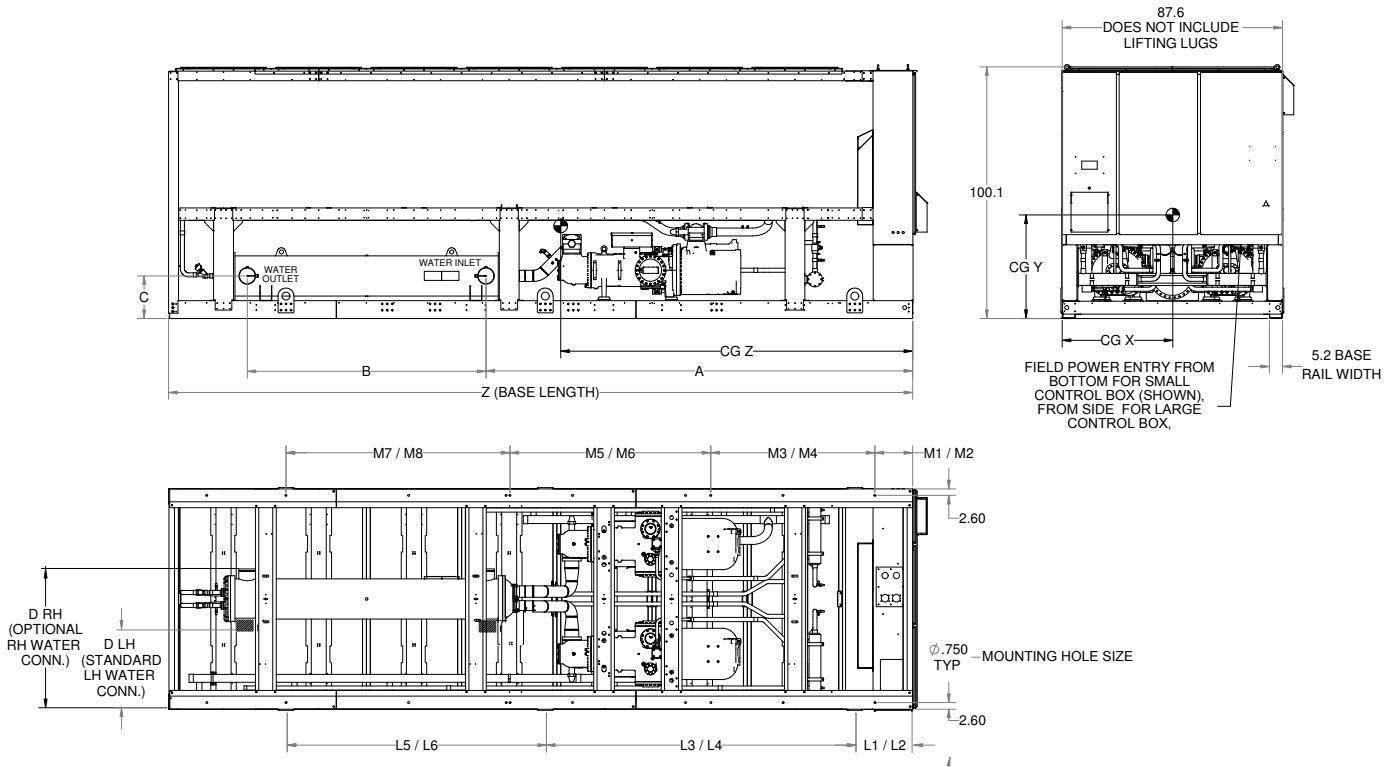
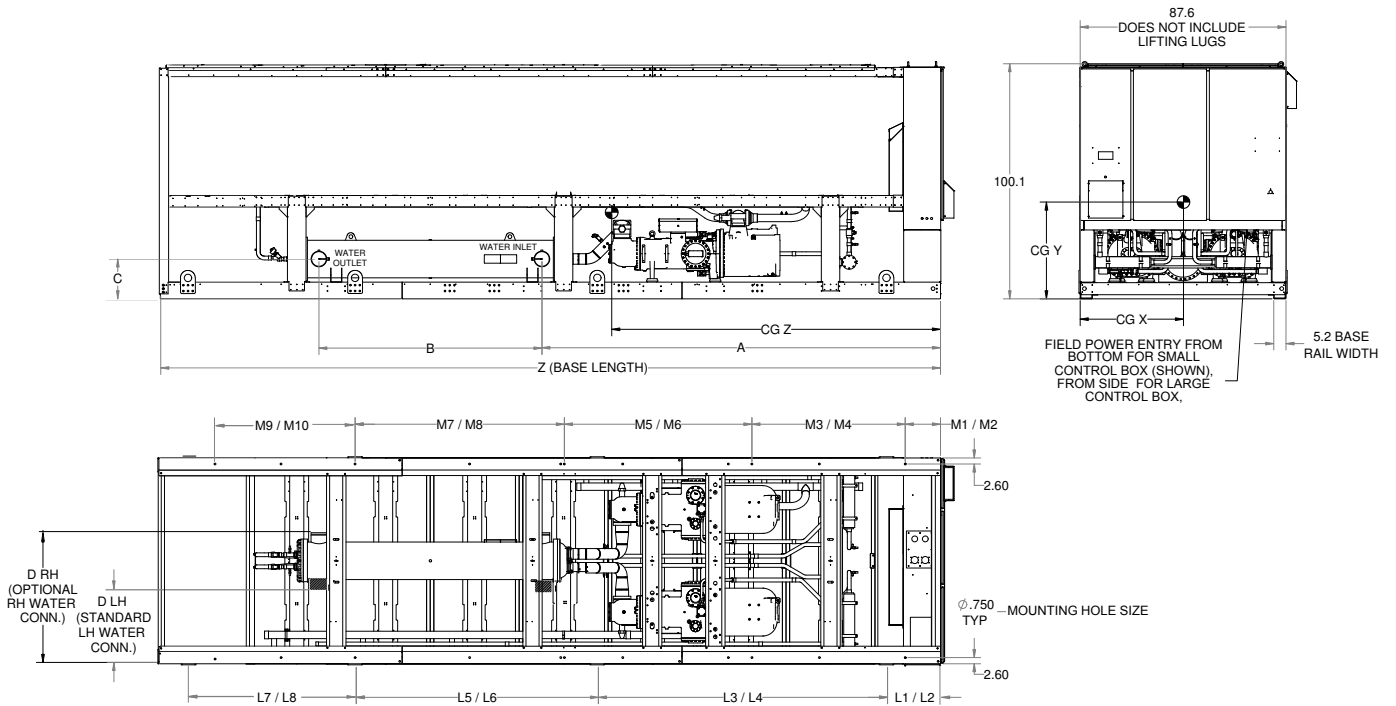

Figure 58: Reference Dimensional Drawing - 16 Fan - 30 Fan Configurations with Shell and Tube Evaporator



NOTE: Water connection sizes are given in Pressure Drop Data starting on [page 45](#).

“L” refers to Lifting Eye Point locations. “M” refers to Mounting Point locations.

IWSE option changes the operational dimensions of the unit; however, added piping is removable, if needed, for installation/service. Consult as-built submittal drawings for dimensional information of units configured with IWSE option.

Table 12: Unit Dimensions by Configuration with Shell and Tube Evaporator

| # OF FANS | EVAP | A | B | C | D LH | D RH | Z | CG X | CG Y | CG Z | L1 / L2 | L3 / L4 | L5 / L6 | L7 / L8 | M1 / M2 | M3 / M4 | M5 / M6 | M7 / M8 | M9 / M10 | | | |
|-----------|---------|-------|-------|------|------|------|-------|--------------------------------------|------|------|---------|---------|---------|---------|---------|---------|---------|---------|----------|-------|-------|-------|
| 12 | EV 4027 | 148.4 | 95.0 | 17.0 | 31.9 | 55.7 | 258.1 | Refer to Submitted As-Built Drawings | | | 23 | 121.3 | 199.6 | N/A | 15 | 80.3 | 135.3 | 200.5 | N/A | | | |
| 14 | EV 4027 | 169.7 | 95.0 | 17.0 | 31.9 | 55.7 | 296 | | | | 23 | 146.1 | 249.3 | | 15 | 80.3 | 160.2 | 249.3 | | | | |
| | EV 5027 | 171.1 | 92.9 | 21.2 | 29.9 | 57.8 | 296 | | | | | | | | | | | | | | | |
| 16 | EV 4027 | 169.7 | 95.0 | 17.0 | 31.9 | 55.7 | 334 | | | | | | | 23 | 78 | 190 | 319.3 | 15 | 80.3 | 135.3 | 200.5 | 290.5 |
| | EV 5027 | 171.1 | 92.9 | 21.2 | 29.9 | 57.8 | 334 | | | | | | | | | | | | | | | |
| | EV 5039 | 171.1 | 138.2 | 21.2 | 29.9 | 57.8 | 334 | | | | | | | | | | | | | | | |
| 18 | EV 4027 | 169.7 | 95.0 | 17.0 | 31.9 | 55.7 | 371.7 | | | | | | | 23 | 78 | 190 | 313 | 15 | 80.3 | 135.3 | 200.5 | 310 |
| | EV 5027 | 171.1 | 92.9 | 21.2 | 29.9 | 57.8 | 371.7 | | | | | | | | | | | | | | | |
| | EV 5039 | 171.1 | 138.2 | 21.2 | 29.9 | 57.8 | 371.7 | | | | | | | | | | | | | | | |
| 20 | EV 5027 | 171.1 | 92.9 | 21.2 | 29.9 | 57.8 | 409.6 | | | | | | | 23 | 135 | 209 | 320 | 15 | 80.3 | 160.2 | 238 | 363 |
| | EV 5039 | 171.1 | 138.2 | 21.2 | 29.9 | 57.8 | 409.6 | | | | | | | | | | | | | | | |
| | EV 6633 | 175.5 | 111.4 | 21.2 | 26.9 | 60.1 | 409.6 | | | | | | | | | | | | | | | |
| 22 | EV 5027 | 171.1 | 92.9 | 21.2 | 29.9 | 57.8 | 447.5 | | | | | | | 23 | 135 | 209 | 365 | 12 | 80.3 | 160.2 | 280 | 380 |
| | EV 5039 | 171.1 | 138.2 | 21.2 | 29.9 | 57.8 | 447.5 | | | | | | | | | | | | | | | |
| | EV 6633 | 175.5 | 111.4 | 21.2 | 26.9 | 60.1 | 447.5 | | | | | | | | | | | | | | | |
| | EV 6639 | 173.7 | 135.0 | 21.2 | 26.9 | 60.1 | 447.5 | | | | | | | | | | | | | | | |
| 24 | EV 5027 | 171.1 | 92.9 | 21.2 | 29.9 | 57.8 | 485.4 | | | | | | | 23 | 135 | 250 | 400 | 15 | 80.3 | 160.2 | 280 | 400 |
| | EV 5039 | 171.1 | 138.2 | 21.2 | 29.9 | 57.8 | 485.4 | | | | | | | | | | | | | | | |
| | EV 6633 | 175.5 | 111.4 | 21.2 | 26.9 | 60.1 | 485.4 | | | | | | | | | | | | | | | |
| | EV 6639 | 173.7 | 135.0 | 21.2 | 26.9 | 60.1 | 485.4 | | | | | | | | | | | | | | | |
| 26 | EV 6633 | 175.5 | 111.4 | 21.2 | 26.9 | 60.1 | 523.2 | | | | 23 | 135 | 250 | 400 | 15 | 80.3 | 160.2 | 280 | 450 | | | |
| | EV 6639 | 173.7 | 135.0 | 21.2 | 26.9 | 60.1 | 523.2 | | | | | | | | | | | | | | | |
| 28 | EV 6633 | 175.5 | 111.4 | 21.2 | 26.9 | 60.1 | 561.0 | | | | 23 | 135 | 250 | 447 | 15 | 80.3 | 160.2 | 280 | 450 | | | |
| | EV 6639 | 173.7 | 135.0 | 21.2 | 26.9 | 60.1 | 561.0 | | | | | | | | | | | | | | | |
| 30 | EV 6633 | 175.5 | 111.4 | 21.2 | 26.9 | 60.1 | 598.9 | | | | 23 | 135 | 321 | 488 | 15 | 80.3 | 200 | 280 | 490 | | | |
| | EV 6639 | 173.7 | 135.0 | 21.2 | 26.9 | 60.1 | 598.9 | | | | | | | | | | | | | | | |

Isolator Installation

Transfer and place the unit as indicated in the Installation section beginning on page 7. In all cases, set the unit in place and level. If anti-skid pads are used, do not use hold down bolts. If hold down bolts are used, do not use anti-skid pads.

Mounting locations for each model configuration can be found in the Dimensional Drawings section beginning on page 41 or in the Submittal As-Built Drawings, available from a Daikin Applied sales representative. Submittal As-Built Drawings also specify the correct isolator color for each mounting location, if ordered.

When spring isolators are required, install springs under the main unit supports. Then unit should be set initially on shims or blocks at the listed spring free height. Isolator springs should not be loaded until all unit installation tasks are complete, then the springs should be adjusted to the vendor listed compression for the load point. When securing the isolator, do not overtighten the mounting bolts. Overtightening may result in cracking of the cast isolator housing and will have a negative impact on the isolation effect.

Installation of spring isolators requires flexible piping connections and at least three feet of flexible electrical conduit to avoid straining the piping and transmitting vibration and noise.

Neoprene waffle pads, supplied by customers, should be mounted at the defined mounting point locations along the full rail width.

Figure 59: Rubber-in-Shear Isolator Schematic

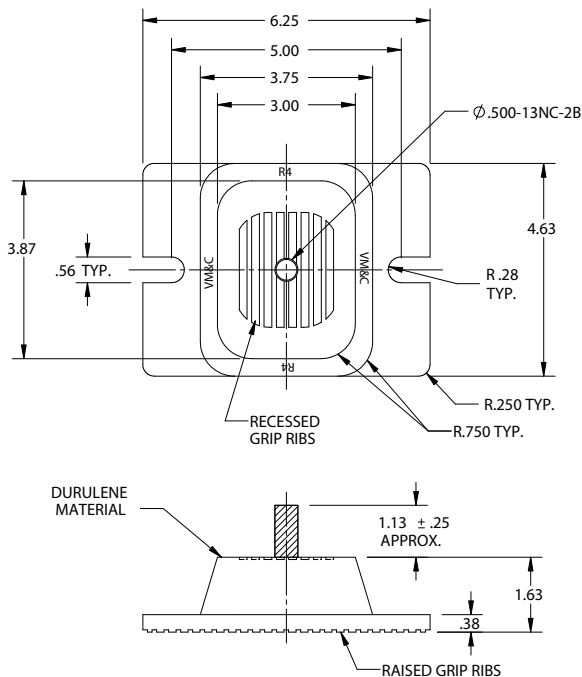

Figure 60: Spring Isolator - 2 Spring Schematic

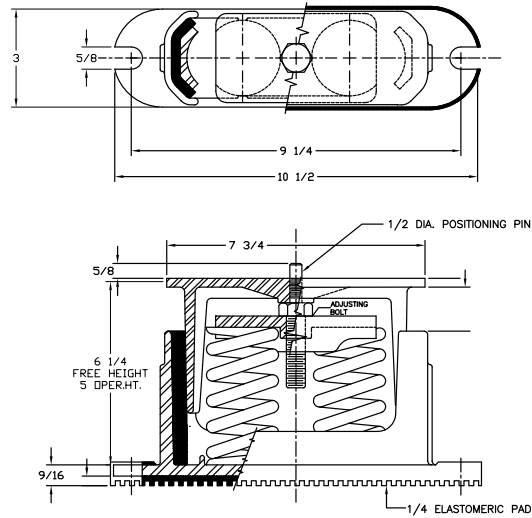

Figure 61: Spring Isolator - 4 Spring Schematic

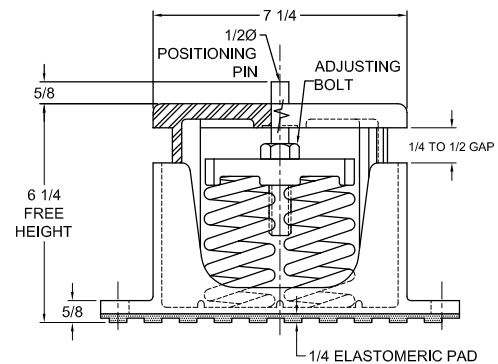
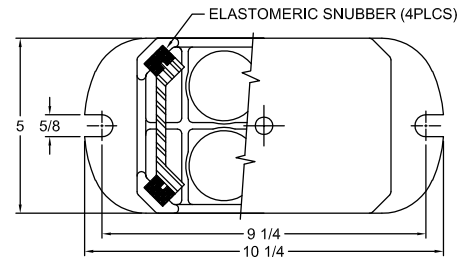

Figure 62: Mounting Location Reference Drawing

AWV - Approximate Mounting Locations
See Dimensional Drawing for exact location

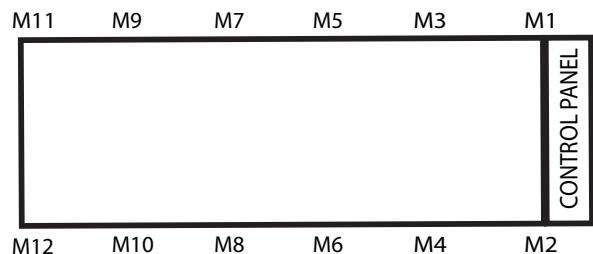
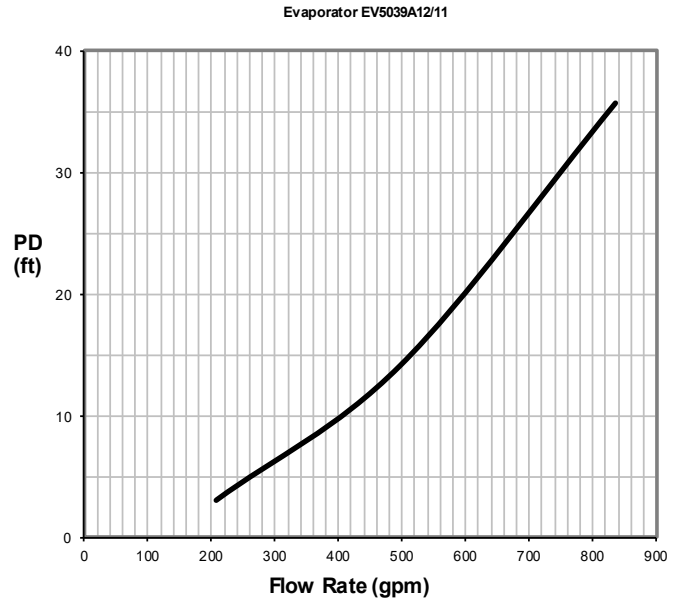

Table 13: Evaporator Flow Limits

| EVAP | Conn. | Minimum | | Maximum | |
|---------------------|------------|---------|------|---------|------|
| | Size (in.) | gpm | ft H | gpm | ft H |
| ACH1000DQ-166AH | 5 | 157.0 | 1.7 | 528.0 | 17.1 |
| ACH1000DQ-206AH | 5 | 197.0 | 2.0 | 660.0 | 16.9 |
| ACH1000DQ-250AH | 5 | 239.0 | 2.0 | 766.0 | 16.8 |
| ACH1000DQ-330AH | 5 | 315.0 | 2.3 | 925.0 | 16.9 |
| EV4027A10/09 | 6 | 148.8 | 2.1 | 595.7 | 26.7 |
| EV4027F10/10 | 6 | 120.5 | 2.2 | 585.0 | 34.5 |
| EV4027A11/07 | 6 | 188.0 | 2.0 | 748.0 | 26.0 |
| EV4027F11/08 | 6 | 152.3 | 2.2 | 585.0 | 21.7 |
| EV4027A12/07 | 6 | 188.0 | 2.3 | 748.0 | 28.1 |
| EV4027F12/08 | 6 | 152.3 | 2.5 | 585.0 | 22.8 |
| EV5027A14/07 | 8 | 219.3 | 2.4 | 876.6 | 28.4 |
| EV5027A17/05 | 8 | 290.6 | 2.6 | 1171.2 | 30.4 |
| EV5039A12/11 | 8 | 207.8 | 3.0 | 834.8 | 35.7 |
| EV6633A15/07 | 10 | 336.4 | 2.7 | 1329.7 | 30.4 |
| EV6633F15/08 - (22) | 10 | 249.9 | 2.5 | 1075.0 | 24.5 |
| EV6633F15/08 - (30) | 10 | 249.9 | 2.5 | 1450.0 | 43.1 |
| EV6639A14/11 | 10 | 260.6 | 3.7 | 1042.6 | 40.6 |
| EV6639A16/09 | 10 | 317.4 | 3.7 | 1261.9 | 41.6 |
| EV6639A17/07 | 10 | 398.5 | 2.7 | 1586.8 | 32.3 |

Figure 63: Model EV5039



NOTE: Flow rates and pressure drops reflect water only and do not apply to glycol solutions.
 (22) and (30) refer to specific fan configurations.

Figure 64: Model ACH1000DQ

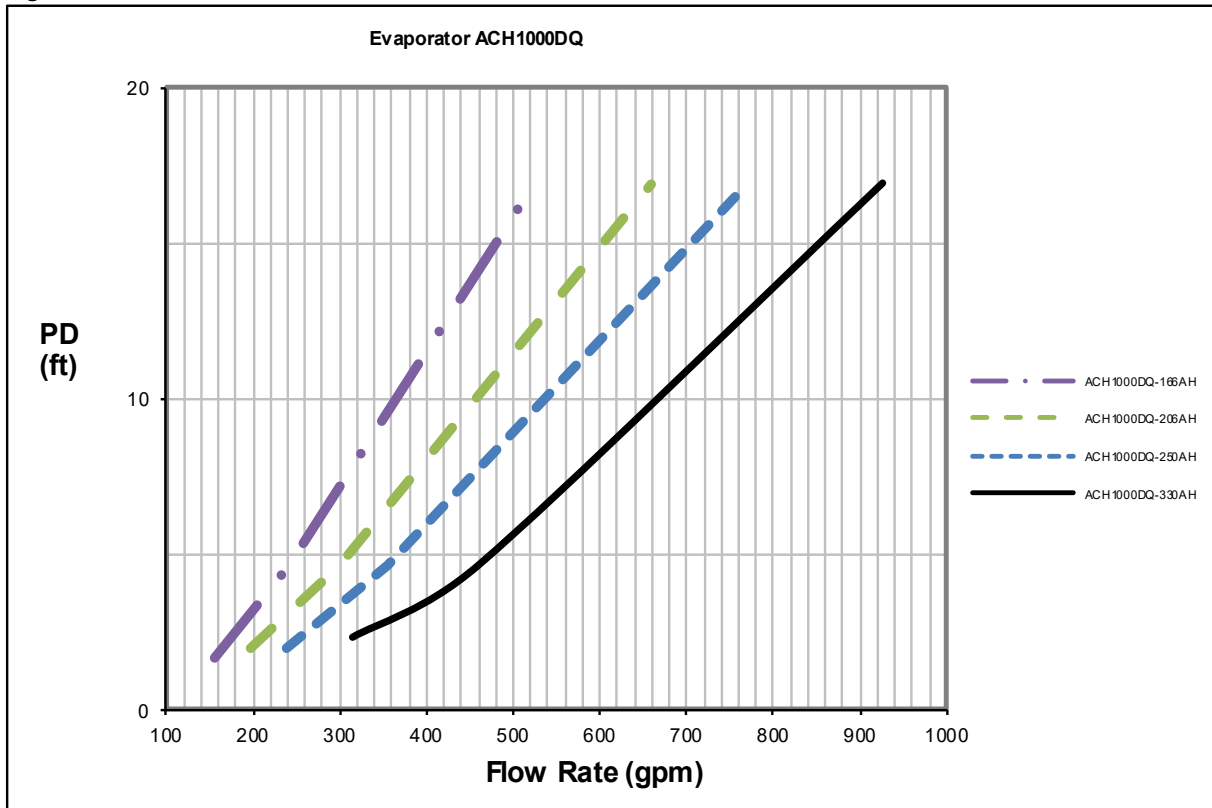

Figure 65: Model EV4027

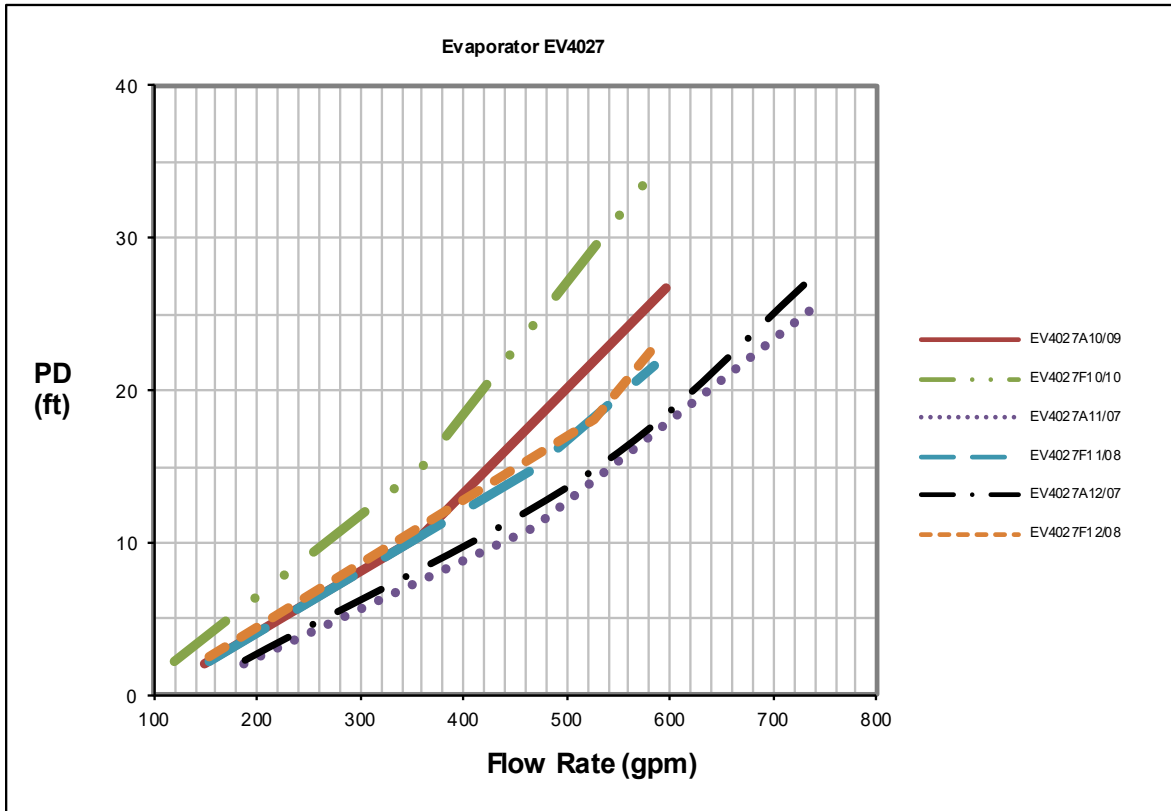

Figure 66: Model EV5027

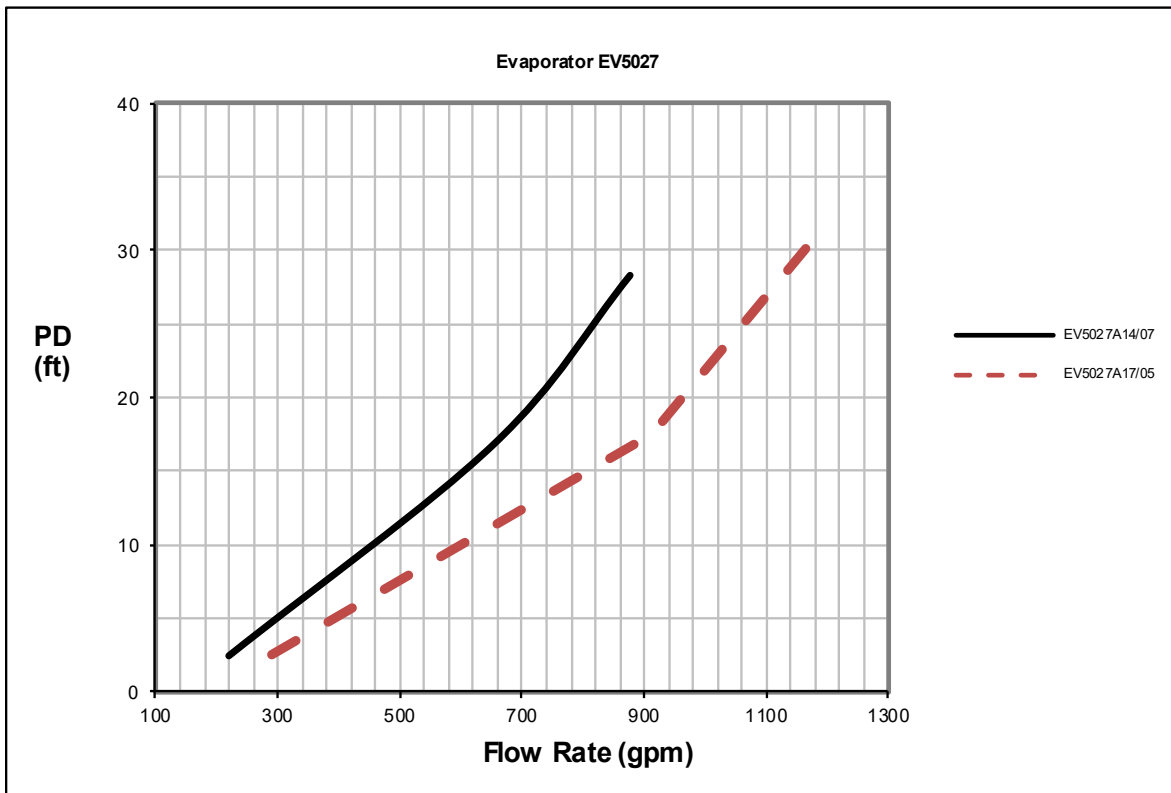

Figure 67: Model EV6633

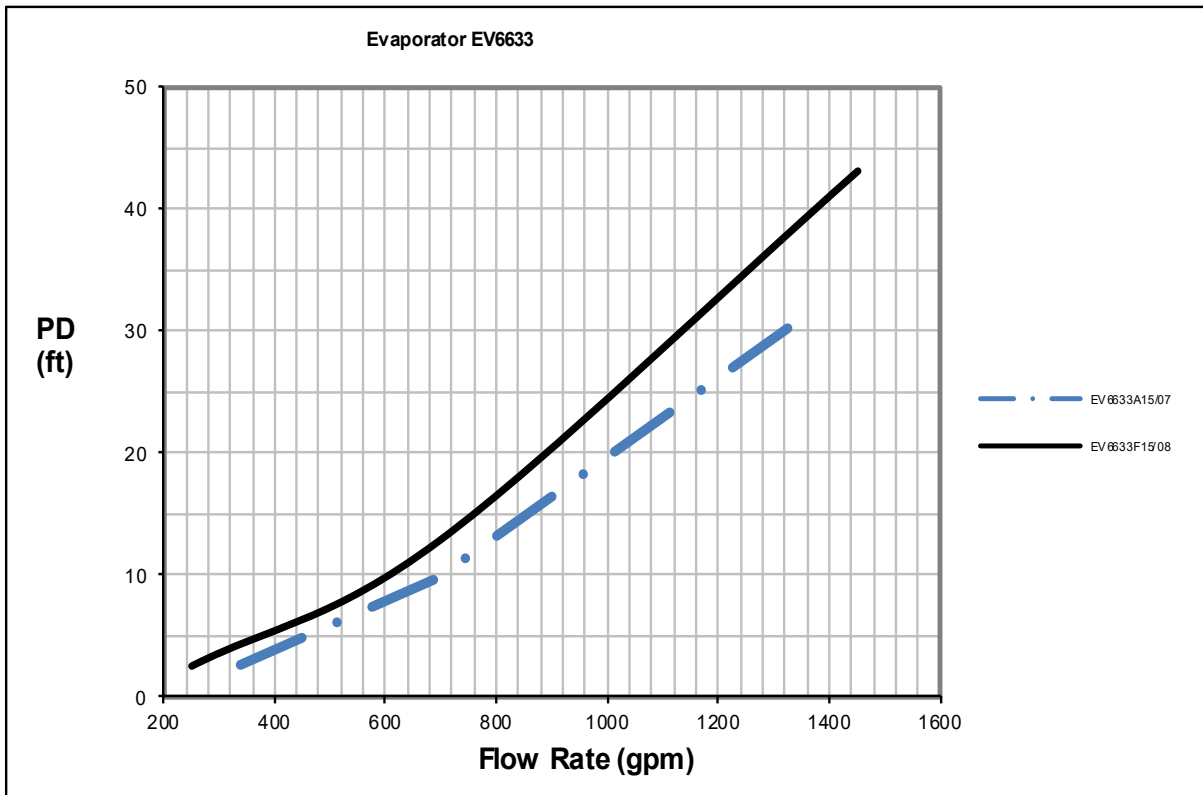
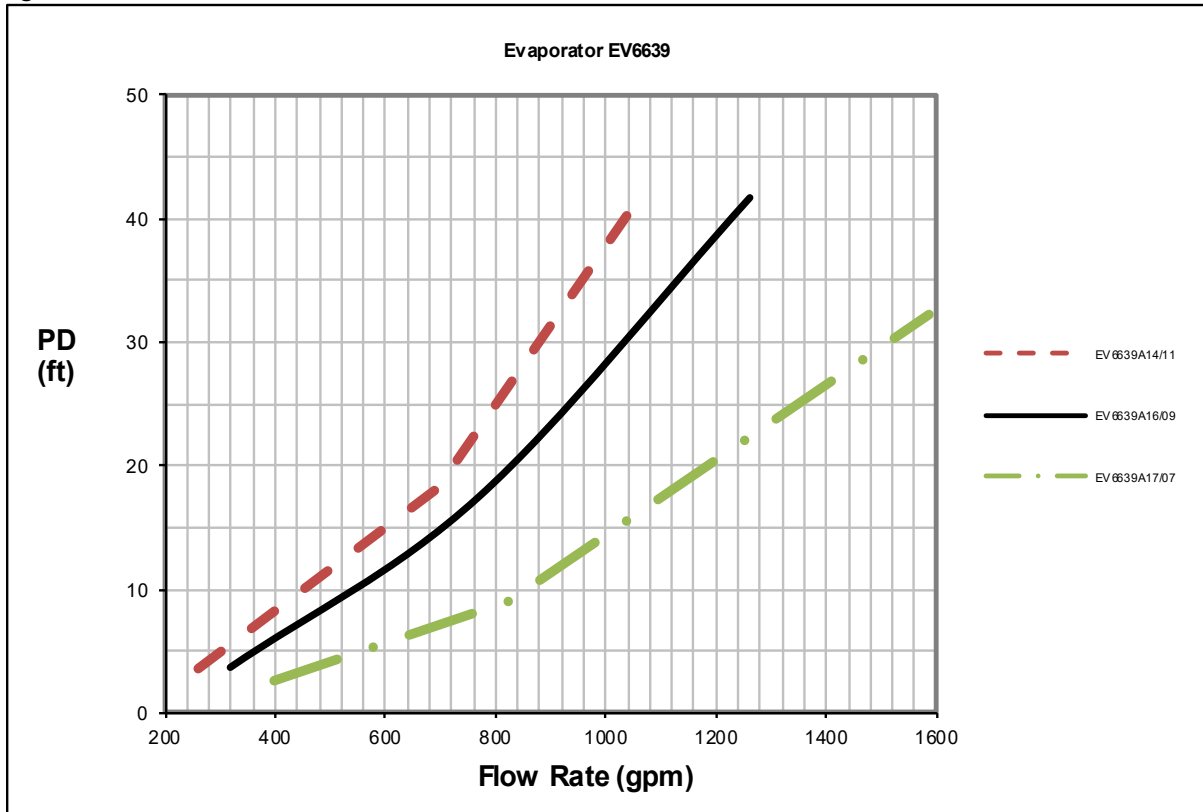

Figure 68: Model EV6639



Operator Responsibilities

It is important that the operator become familiar with the equipment and the system before attempting operation. During the initial startup of the chiller, the Daikin Applied service technician will be available to answer any questions and instruct the proper operating procedures. It is recommended that the operator maintain an operating log for each individual chiller unit. In addition, a separate maintenance log should be kept of the periodic maintenance and servicing activities.

Operator Schools

Training courses for Pathfinder® Air-Cooled Screw Maintenance and Operation are held throughout the year at the Daikin Learning Institute in Verona, Virginia. The class includes instruction on basic refrigeration, MicroTech® III controllers, enhancing chiller efficiency and reliability, MicroTech® III troubleshooting, system components, and other related subjects. For more information, refer to the back cover of this document for Training contact information.

Software Version

The unit software and BSP (Board Support Package) versions can be viewed using the keypad/display. From the Main Menu, turn the knob to the right to reach the About Chiller menu and press Enter (the knob). The software version is displayed as "App Version =". Scroll down in this menu (turn knob to the right), the BSP version will also be displayed ("BSP Version=").

WARNING

Electric shock hazard: can cause personal injury or equipment damage. This equipment must be properly grounded. Connections to, and service of, the MicroTech® III control panel must be performed only by personnel who are knowledgeable in the operation of this equipment.

CAUTION

Static sensitive components. A static discharge while handling electronic circuit boards can cause damage to the components. Use a static strap before performing any service work. Never unplug any cables, circuit board terminal blocks, or power plugs while power is applied to the panel.

NOTICE

This equipment generates, uses, and can radiate radio frequency energy and, if not installed and used in accordance with this instruction manual, can cause interference to radio communications. Operation of this equipment in a residential area can cause harmful interference, in which case the user will be required to correct the interference at the user's own expense. Daikin disclaims any liability resulting from any interference or for the correction thereof.

General Description

The MicroTech® III control system consists of a controller and a number of extension input/output (I/O) modules, which vary depending on the unit size and configuration. The control system provides the monitoring and functions required for the controlled, efficient operation of the chiller. The MicroTech® III controllers used on Pathfinder® chillers are not interchangeable with previous MicroTech® II controllers.

The operator can see all critical operating conditions by using the screen located on the main controller. In addition to providing all normal operating controls, the MicroTech® III control system will take corrective action if the chiller is operating outside of its normal design conditions.

The control panel is located on the front of the unit at the compressor end. There are three doors. The control panel is behind the left-hand door. The power panels are behind the middle and right-hand doors. The control power transformer is located in the power panel adjacent to the control panel.

Controller Features

- Readout of the following temperature and pressure readings:
 - Entering and leaving chilled water temperature
 - Saturated temperatures and pressures for evaporator and condenser
 - Outside air temperature
 - Suction and discharge temperatures with calculated superheat for discharge and suction lines
 - Oil pressure and temperature
 - Suction and discharge pressure
- Automatic control of primary and standby chilled water pumps. The control will start one of the pumps (based on lowest run-hours) when the unit is enabled to run (not necessarily running on a call for cooling) and when the water temperature reaches a point of freeze possibility.
- Three levels of security protection against unauthorized changing of set points and other control parameters.
- Warning and fault diagnostics to inform operators of conditions in plain language. All events and alarms are time and date-stamped for identification of when the fault condition occurred.
- Twenty-five previous alarms are available.
- Remote input signals for chilled water reset, demand limiting, and unit enable.
- Test mode allows the service technician to manually control the outputs and can be used for a system check.
- Building Automation System (BAS) communication capability via LonTalk®, Modbus®, or BACnet® standard protocols for all BAS manufacturers.
- Pressure transducers for direct reading of system pressures.

NOTE: The Emergency Switch Relay, located on the front of the control panel door when ordered, de-energizes the control power of all circuits when activated, causing an immediate compressor and fan shutdown.

System Architecture

The overall controls architecture uses the following:

- One MicroTech® III unit controller
- I/O extension modules (sometimes referred to as "controllers") as needed depending on the configuration of the unit
- Up to three BAS interface modules as needed based on installed options

Modbus Communication - Unit

The unit controller (UC) communicates to the compressor VFD's and the EXV modules via the Modbus RTU connection on the controller itself. Communication to the VFD's and EVAP EXV MODULE is required for operation in all configurations. Communication to ECON EXV MODULE is required only if the chiller is configured with economizers.

Figure 77: System Architecture Schematic

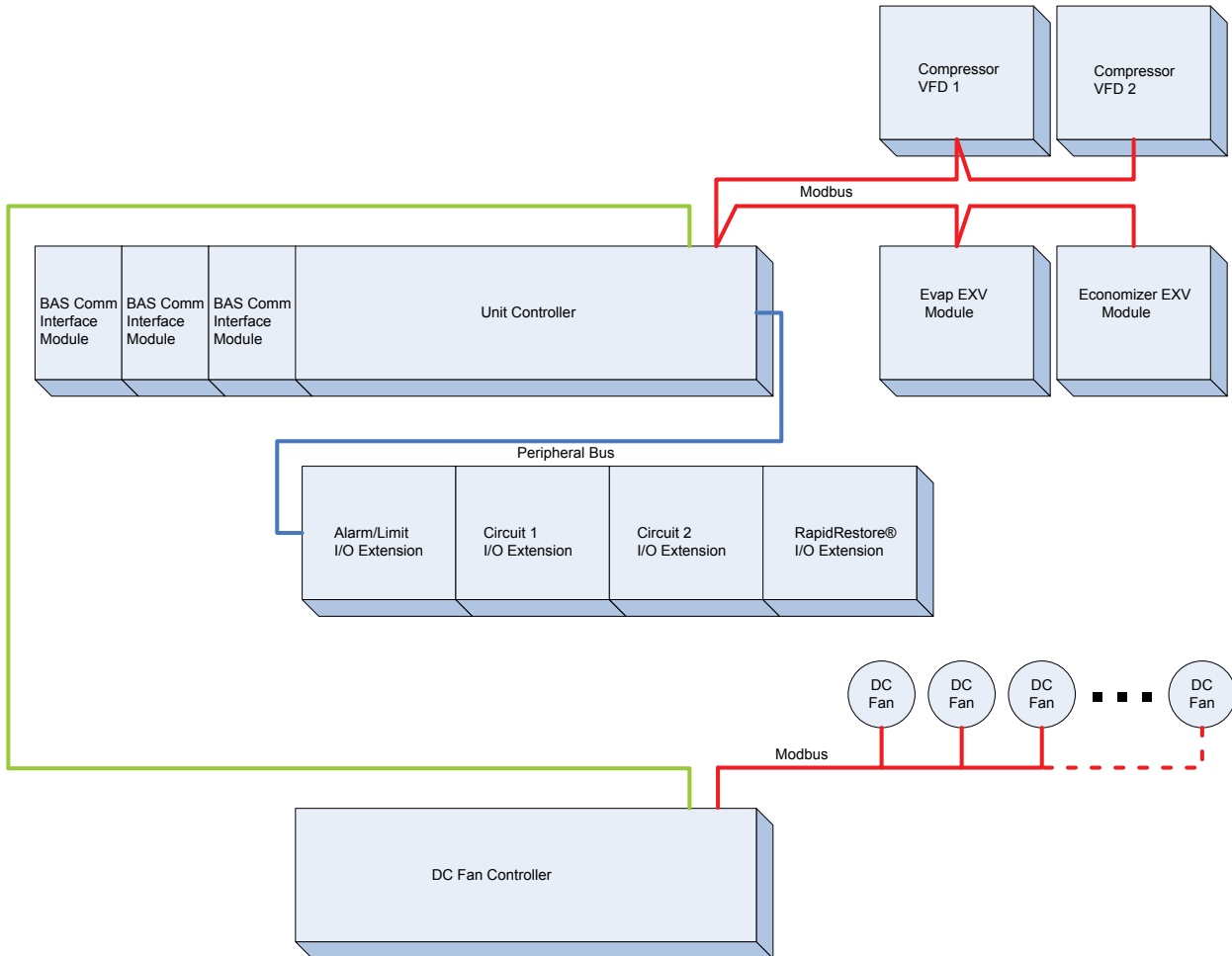

NOTE: Graphic shows typical chiller controller arrangement; individual chiller configurations will be as ordered.

MicroTech® III Inputs/Outputs

Unit Controller - UC Module

Table 14: Analog Inputs - Evaporator

| # | Description | Signal Source |
|-----|-----------------------------|---------------------------|
| AI1 | Evap Entering Water Temp | NTC Thermister (10K@25°C) |
| AI2 | Evap Leaving Water Temp | NTC Thermister (10K@25°C) |
| AI3 | Outside Ambient Temperature | NTC Thermister (10K@25°C) |
| X4 | LWT Reset | 4-20 mA Current |

Table 15: Analog Outputs - Fan VFD

| # | Description | Output Signal |
|----|-------------|---------------|
| X5 | Fan VFD #1 | 0-10 Vdc |
| X6 | Fan VFD #2 | 0-10 Vdc |

Table 16: Digital Inputs

| # | Description | Signal Off | Signal On |
|-----|------------------------|--------------|-------------|
| DI1 | GFP Relay 1 | Fault | No Fault |
| DI2 | Evaporator Flow Switch | No Flow | Flow |
| DI3 | Mode Switch | Cool mode | Ice mode |
| DI4 | Remote Switch | Unit disable | Unit enable |
| DI5 | Unit Switch | Unit disable | Unit enable |
| DI6 | Emergency Stop | Unit off | Unit enable |
| X8 | GFP Relay 2 | Fault | No Fault |

Table 17: Digital Outputs

| # | Description | Output OFF | Output ON |
|------|--------------------------|------------------|--------------|
| DO1 | Evaporator Water Pump 1 | Pump Off | Pump On |
| DO2 | Alarm Relay | Alarm not Active | Alarm Active |
| DO3 | Circuit #1 Fan Output #1 | Fan(s) Off | Fan(s) On |
| DO4 | Circuit #1 Fan Output #2 | Fan(s) Off | Fan(s) On |
| DO5 | Circuit #1 Fan Output #3 | Fan(s) Off | Fan(s) On |
| DO6 | Circuit #1 Fan Output #4 | Fan(s) Off | Fan(s) On |
| DO7 | Circuit #2 Fan Output #1 | Fan(s) Off | Fan(s) On |
| DO8 | Circuit #2 Fan Output #2 | Fan(s) Off | Fan(s) On |
| DO9 | Circuit #2 Fan Output #3 | Fan(s) Off | Fan(s) On |
| DO10 | Circuit #2 Fan Output #4 | Fan(s) Off | Fan(s) On |

CC Modules - Circuit #1 and #2

Table 18: Analog Inputs - For Each Circuit

| # | Description | Signal Source |
|----|-----------------------|---------------------------|
| X1 | Discharge Temperature | NTC Thermister (10K@25°C) |
| X2 | Suction Temperature | NTC Thermister (10K@25°C) |
| X5 | Evaporator Pressure | Ratiometric 0.5-4.5 Vdc |
| X6 | Oil Pressure | Ratiometric 0.5-4.5 Vdc |
| X7 | Condenser Pressure | Ratiometric 0.5-4.5 Vdc |

Table 19: Digital Outputs - For Each Circuit

| # | Description | Output Off | Output On |
|-----|------------------------|-----------------|---------------|
| DO1 | Compressor Run Command | Compressor Off | Compressor On |
| DO2 | Liquid Line SV | Solenoid Closed | Solenoid Open |
| DO3 | Liquid Injection SV | Solenoid Closed | Solenoid Open |
| DO4 | 100% VR SV | Solenoid Closed | Solenoid Open |
| DO5 | 75% VR SV | Solenoid Closed | Solenoid Open |
| DO6 | 50% VR SV | Solenoid Closed | Solenoid Open |
| X8 | Economizer SV | Solenoid Closed | Solenoid Open |

EEXV Modules - Circuit #1 and #2

Table 20: Digital Inputs

| # | Description | Signal Off | Signal On |
|-----|--------------------------------|------------|-----------|
| DI1 | Mechanical Low Pressure Switch | Fault | No Fault |

Table 21: Digital Outputs

| # | Description | Output OFF | Output ON |
|-----|---------------|-----------------|---------------|
| DO1 | Economizer SV | Solenoid Closed | Solenoid Open |

Table 22: EEXV Stepper Motor Output

| # | Description |
|-----|---|
| M1+ | Circuit # Evaporator EXV Stepper Coil 1 |
| M1- | |
| M2+ | Circuit # Evaporator EXV Stepper Coil 2 |
| M2- | |

Evaporator EXV Module

Table 23: EXV Stepper Outputs

| Driver | Description |
|--------|---------------------------|
| A | Evaporator EXV Circuit #1 |
| B | Evaporator EXV Circuit #2 |

Economizer EXV Module

Table 24: Analog Inputs

| # | Description | Signal Source |
|----|-----------------------------------|-------------------------|
| S1 | Economizer Pressure Circuit #1 | Ratiometric 0.5-4.5 Vdc |
| S2 | Economizer Temperature Circuit #1 | NTC 10K Thermister |
| S3 | Economizer Pressure Circuit #2 | Ratiometric 0.5-4.5 Vdc |
| S4 | Economizer Temperature Circuit #2 | NTC 10K Thermister |

Table 25: EXV Stepper Outputs

| Driver | Description |
|--------|---------------------------|
| A | Economizer EXV Circuit #1 |
| B | Economizer EXV Circuit #2 |

Alarm/Limit Module

Table 26: Analog Inputs

| # | Description | Signal Source |
|----|--------------|---------------|
| X3 | Demand Limit | 4-20 mA |

Table 27: Digital Inputs

| # | Description | Signal Off | Signal On |
|----|-------------------|-------------------------|--------------------|
| X1 | External Alarm | External Device Failure | External Device OK |
| X5 | Circuit #1 Switch | Circuit Off | Circuit On |
| X6 | Circuit #2 Switch | Circuit Off | Circuit On |

Table 28: Digital Outputs

| # | Description | Output Off | Output On |
|-----|--------------------------|------------|-----------|
| DO1 | Evaporator Water Pump 2 | Pump Off | Pump On |
| DO3 | Circuit #1 Fan Output #5 | Fan(s) Off | Fan(s) On |
| DO4 | Circuit #1 Fan Output #6 | Fan(s) Off | Fan(s) On |
| DO5 | Circuit #2 Fan Output #5 | Fan(s) Off | Fan(s) On |
| DO6 | Circuit #2 Fan Output #6 | Fan(s) Off | Fan(s) On |

RapidRestore® Module

Table 29: Digital Inputs

| # | Description | Signal Off | Signal On |
|-----|---------------------|-----------------|----------------|
| DI1 | RapidRestore Unlock | Lock Out Option | Unlock Option |
| DI2 | Backup Chiller | Normal Chiller | Backup Chiller |

Compressor VFDs

Table 30: Digital Inputs

| # | Description | Signal Off | Signal On |
|----|---------------------------------|------------|-----------|
| H1 | Circuit # | Alarm | No Alarm |
| S6 | Mechanical High Pressure Switch | | |

Waterside Economizer Module

Table 31: Analog Inputs

| # | Description | Signal Source |
|-------|---------------------------------------|--------------------|
| UC X1 | Waterside Economizer EWT | NTC 10k Thermistor |
| AC X7 | Waterside Economizer Valve 1 Position | 4 to 20 mA |
| AC X8 | Waterside Economizer Valve 2 Position | 4 to 20 mA |

Table 32: Analog Outputs

| # | Description | Signal Source |
|-------|---|---------------|
| AC X2 | Waterside Economizer Valve 1 Position Command | 4 to 20 mA |
| AC X4 | Waterside Economizer Valve 2 Position Command | 4 to 20 mA |

Table 33: Digital Inputs

| # | Description | Signal Off | Signal On |
|--------|-----------------------------|------------|-----------|
| AC DI1 | Waterside Economizer Enable | Disable | Enable |

Table 34: Digital Outputs

| # | Description | Signal Off | Signal On |
|--------|-----------------------------|------------|-----------|
| AC DO2 | Waterside Economizer Status | Inactive | Active |

Set Points

The following parameters are remembered during power off (permanent memory), are factory set to the Default value, and can be adjusted to any value in the Range column. Read and write access to these set points is determined by the Global HMI (Human Machine Interface) Standard Specification.

Unit Level Set Points

All of these settings require the unit switch to be off in order to make a change and require rebooting the controller in order to apply a change. Unit modes Cool/Ice and Ice will both require Evaporator Glycol set point to have Yes selected.

Table 35: Set Point Default and Range

| Description | Default | Range |
|-------------------------------------|---------------------|--|
| Basic Unit Configuration | | |
| Input Voltage | Not Set | Not Set, 380, 400, 460, 575 |
| Evaporator Configuration | Not Set | Not Set, Packaged, Remote |
| Ground Fault Protection Option | No | No, Single Point, Multi Point |
| Economizers | Yes | No, Yes |
| Economizer Piping | Not Set | Not Set, Steel, Copper |
| Liquid Line Solenoid Valves | No | No, Yes |
| Liquid Injection | No | No, Yes |
| Condenser Fan Configuration | Not Set | Not Set, No VFD, 1st Fan VFD, All Fan VFD |
| RapidRestore | No | No, Yes |
| Evaporator Glycol | No | No, Yes - Modes Cool/Ice and Ice will require Evaporator Glycol to be Yes. |
| Available Modes | Cool | Cool, Cool/Ice, Ice |
| Compressor VFD Parameter Set | No | No, Yes |
| Circuit #1 Compressor Type | Not Set | Not Set, F3ALVVR60, F3ALVVR86, F3BLVVR86, F4ALVVR80 |
| Circuit #2 Compressor Type | Not Set | Not Set, F3ALVVR60, F3ALVVR86, F3BLVVR86, F4ALVVR80 |
| Circuit #1 Compressor Max Speed | 45 Hz | 45 to 60, 45 to 70, 45 to 80, 45 to 86, 45 to 90 - Dependent on type |
| Circuit #2 Compressor Max Speed | 45 Hz | 45 to 60, 45 to 70, 45 to 80, 45 to 86, 45 to 90 - Dependent on type |
| Circuit 1 Compressor VFD Input RLA | 100 | 1 to 1000 amps |
| Circuit 2 Compressor VFD Input RLA | 100 | 1 to 1000 amps |
| Circuit #1 Number of Fans | Not Set | Not Set, 4, 6, 8, 10, 12, 14, 16 |
| Circuit #2 Number of Fans | Not Set | Not Set, 4, 6, 8, 10, 12, 14, 16 |
| Circuit #1 Evaporator EXV Type | Not Set | Not Set, E6V, ETS50, ETS100, ETS250, ETS400 |
| Circuit #2 Evaporator EXV Type | Not Set | Not Set, E6V, ETS50, ETS100, ETS250, ETS400 |
| Unit Mode and Enabling | | |
| Unit Enable | Enable | Disable, Enable |
| Unit Enable Initial Value | Enable | Disable, Enable |
| Control source | Local | Local, Network |
| Unit Test Mode | Off | Off, On |
| Staging and Capacity Control | | |
| Cool LWT | 6.67°C (44°F) | See Dynamic Set Point Ranges section |
| Ice LWT | -3.89°C (25°F) | -8.33°C to -2.22°C (17°F to 28°F) |
| Startup Delta T | 2.7°C (4.9°F) | 1.67 to 5.0°C (3 to 9.0°F) |
| Shut Down Delta T | 1.5°C (2.7°F) | 0 to 2°C (0 to 3.6°F) |
| Stage Up Delta T | 1.0°C (1.8°F) | 0 to 2°C (0 to 3.6°F) |
| Stage Down Delta T | 1.0°C (1.8°F) | 0 to 1.7°C (0 to 3.1°F) |
| Stage Up Delay | 3 minutes | 0 to 60 minutes |
| Stage Delay Clear | No | No, Yes |
| EWT Pulldown Limit Max | 3°C/min (5.4°F/min) | 2 to 6°C/min (3.6 to 10.8°F/min) |
| Light Load Stage Down | 40% | 20 to 50% |
| High Load Stage Up | 80% | 50 to 90% |
| Max Number of Circuits Running | 2 | 1-2 |
| Sequence Number Circuit #1 - #2 | 1 | 1-2 |
| Ice Cycle Delay | 12 | 1-23 hours |
| Clear Ice Delay | No | No, Yes |
| RapidRestore Max Power Off Time | 15 seconds | 15 to 180 seconds |

Table 36: Set Point Default and Range (continued)

| Description | Default | Range |
|--|---------------------------|--|
| Waterside Economizer Control | | |
| Waterside Economizer Option | No | No, Yes |
| Waterside Economizer Enable | Yes | No, Yes |
| BAS Waterside Econ Command | Disable | Disable, Enable |
| Waterside Economizer Valve 1 Test | 100% | 0 to 100% |
| Waterside Economizer Valve 2 Test | 0% | 0 to 100% |
| Evaporator Pump Control | | |
| Evap Pump Control Configuration | #1 Only | #1 Only, #2 Only, Auto, #1 Primary, #2 Primary |
| Evap Recirc Timer | 90 seconds | 0 to 300 seconds |
| Evap Pump 1 Run Hours | 0 | 0 to 999999 hours |
| Evap Pump 2 Run Hours | 0 | 0 to 999999 hours |
| Evap Pump 1 Starts | 0 | 0 to 999999 starts |
| Evap Pump 2 Starts | 0 | 0 to 999999 starts |
| Power Conservation and Limits | | |
| LWT Reset Enable | Disable | Disable, Enable |
| Max Reset | 5.0°C (9.0°F) | 0 to 10.0°C (0 to 18.0°F) |
| Demand Limit Enable | Off | Off, On |
| Unit Sensor Offsets | | |
| Evap LWT Sensor Offset | 0°C (0°F) | -5.0 to 5.0°C (-9.0 to 9.0°F) |
| Evap EWT Sensor Offset | 0°C (0°F) | -5.0 to 5.0°C (-9.0 to 9.0°F) |
| OAT Sensor Offset | 0°C (0°F) | -5.0 to 5.0°C (-9.0 to 9.0°F) |
| Circuit Configuration - Applied to All Circuits | | |
| Pumpdown Pressure Max | 160 kPa (23.2 psi) | 70 to 280 kPa (10.2 to 40.6 psi) |
| Pumpdown Time Limit | 120 seconds | 0 to 180 seconds |
| Liquid Injection Activation | 85.0°C (185.0°F) | 50.0°C to 110.0°C (122.0°F to 230.0°F) |
| Start-Start Time Delay | 20 minutes | 15-60 minutes |
| Stop-Start Time Delay | 5 minutes | 3-20 minutes |
| Alarm and Limit Settings - Unit | | |
| Evaporator Fluid Freeze | 2.2°C (36.0°F) | See Dynamic Set Point Ranges section |
| Evaporator Flow Loss Delay | 15 seconds | 5 to 15 seconds |
| Evaporator Recirculate Timeout | 3 minutes | 1 to 10 minutes |
| Low OAT Lockout | 0°C (32°F) | See Dynamic Set Point Ranges section |
| Low OAT Lockout Configuration ¹ | Lockout & Stop | Lockout & Stop, Lockout Only, Disabled |
| Low OAT Lockout BAS Alert | Off | Off, On |
| Alarm and Limit Settings - Circuits | | |
| Low Evap Pressure-Unload | 160 kPa (23.2 psi) | See Dynamic Set Point Ranges section |
| Low Evap Pressure-Hold Offset | 15 kPa (2.2 psi) | 10 to 50 kPa (1.5 to 7.3 psi) |
| High Oil Press Difference Delay | 60 seconds | 10-600 seconds |
| High Oil Press Difference Minimum | Compressor Type Dependant | Compressor Type Dependant |
| High Discharge Temperature | 110.0°C (230.0°F) | 65.0 to 110.0°C (149.0 to 230.0°F) |
| High Cond Pressure Delay | 5 seconds | 0 to 5 seconds |
| High Cond Pressure Hold Offset ² | 2.8°C (5°F) | 2.8 to 8.3°C (5 to 15°F) |
| High Cond Pressure Unload Offset | 1.7°C (3°F) | 1.7 to 7.2°C (3 to 13°F) |
| Low Pressure Differential/Ratio Delay | 120 seconds | 120 to 300 seconds |
| Low DSH Limit | 2.0°C (3.6°F) | 1.0°C to 15.0°C (1.8 to 27°F) |
| Pumpdown Time Limit | 120 seconds | 0 to 180 seconds |

- NOTE:**
1. Low Ambient Lockout Configuration will not be available unless Fan VFD Configuration is set to 1st Fan VFD or All Fan VFD.
 2. High Condenser Pressure Hold Offset is forced to be at least 1.1°C (2°F) greater than High Condenser Pressure Unload Offset.

Table 37: Unit Test Mode Set Points

| Description | Default | Range |
|-------------------------------|---------|---------|
| Test Unit Alarm Output | Off | Off, On |
| Test Evaporator Pump Output 1 | Off | Off, On |
| Test Evaporator Pump Output 2 | Off | Off, On |

NOTE: Unit test mode set points can be changed only when the unit mode is Test. When the unit mode is no longer Test, all unit test mode set points will be changed back to the 'off' values.

Table 38: Administration and Service Support

| Description | Default | Range |
|---|----------------------------|---|
| Unit G.O. Number | "Enter Data" | Alphanumeric string of up to 16 characters |
| Unit Serial Number | "Enter Data" | Alphanumeric string of up to 20 characters |
| Next Maintenance Month | January | January through December |
| Next Maintenance Year | 2009 | 2009 - 2100 |
| Service Support Reference | 999-999-9999 | Any 10 digit phone number |
| Controller Time | From Controller Time clock | 00:00:00 to 23:59:59 |
| Controller Date | From Controller Time clock | 1/1/2000 to 12/31/2050 |
| UTC Difference | -60 minutes | -3276 to 32767 minutes |
| Daylight Savings Time Enable | Yes | No, Yes |
| Daylight Savings Time Start Month | March | January through December |
| Daylight Savings Time Start Week | 2nd Week | 1st through 5th Week |
| Daylight Savings Time End Month | November | January through December |
| Daylight Savings Time End Week | 1st Week | 1st through 5th Week |
| Operator Password Disable | Off | Off, On |
| Apply Changes | No | No, Yes |
| Active Alarm Clear | Off | Off, On |
| Alarm Log Clear | No | No, Yes |
| Power Restore Event Log - Day Selection | Current | Current, 2nd Day, 3rd Day, 4th Day, 5th Day, 6th Day, 7th Day |
| Display Units | English | English, Metric |

Dynamic Set Point Ranges

The following settings have different ranges of adjustment based on other settings.

Table 39: Cool LWT Set Point Ranges

| Evaporator Glycol | Range |
|-------------------|-------------------------------|
| No | 4.44 to 21.12°C (40 to 70°F) |
| Yes | -3.89 to 21.12°C (25 to 70°F) |

Table 40: Evaporator Fluid Freeze

| Evaporator Glycol | Range |
|-------------------|-------------------------------|
| No | 1.1 to 6°C (34 to 42.8°F) |
| Yes | -28.89 to 6°C (-20 to 42.8°F) |

Table 41: Low Ambient Lockout

| Condenser Fan VFD | Range |
|--------------------------|------------------------------|
| None | 0 to 15°C (32 to 59°F) |
| 1st Fan VFD, All Fan VFD | -28.89 to 15°C (-20 to 59°F) |

NOTE: Unless Low Ambient Lockout is disabled.

Table 42: Low Evaporator Pressure Unload

| Evaporator Glycol | Range |
|-------------------|---------------------------------|
| No | 150 to 510 kPa (21.8 to 74 psi) |
| Yes | 0 to 510 kPa (0 to 74 psi) |

Circuit Level Set Points

The settings in this section all exist for each individual circuit.

Table 43: Set Points for Individual Circuits

| Description | Default | Range |
|------------------------------------|---|---|
| Mode, Enabling, Configuration | | |
| Circuit Mode | Enable | Disable, Enable, Test |
| Capacity Control | Auto | Auto, Manual |
| Manual Speed | See Note 1 | |
| Condenser Control | | |
| Condenser Temp Target Max | 50.0°C (122°F) | 30.0°C to 55.0°C (86°F to 131°F) |
| Fan Staging Deadbands | See Table 44 and Table 45 | 1 to 10°C (1.8 to 18°F) |
| Sensor Offsets | | |
| Evap Pressure Offset | 0 kPa (0 psi) | -100 to 100 kPa (-14.5 to 14.5 psi) |
| Cond Pressure Offset | 0 kPa (0 psi) | -100 to 100 kPa (-14.5 to 14.5 psi) |
| Oil Pressure Offset | 0 kPa (0 psi) | -100 to 100 kPa (-14.5 to 14.5 psi) |
| Economizer Pressure Offset | 0 kPa (0 psi) | -100 to 100 kPa (-14.5 to 14.5 psi) |
| Suction Temp Offset | 0°C (0°F) | -5.0 to 5.0°C (-9.0 to 9.0°F) |
| Discharge Temp Offset | 0°C (0°F) | -5.0 to 5.0°C (-9.0 to 9.0°F) |
| Economizer Temp Offset | 0°C (0°F) | -5.0 to 5.0°C (-9.0 to 9.0°F) |
| Administrative and Service Support | | |
| Clear Cycle Timers | No | No, Yes |
| Service Pumpdown | Off | Off, On |
| Compressor Run Hours | 0 | 0 to 999999 hours |
| Compressor Starts | 0 | 0 to 65535 |
| Event Log - Event Selection | Low Pressure Hold | Low Press Hold, Low Press Unload, High Press Hold, Hi Press Unload, Low Pr Diff/Ration, Hi Motor Amps Hold, Hi Motor Amps Unload, Hi VFD Amps Hold, Hi VFD Amps Unld, Hi VFD Temp Hold, Hi VFD Temp Unld, Comp Start Fail, Part Load Shutdown |
| Event Log - Day Selection | Current | Current, 2nd Day, 3rd Day, 4th Day, 5th Day, 6th Day, 7th Day |

NOTE: The Manual Speed value will follow the compressor speed command while Speed Control = Auto. When Speed Control = Manual, the Manual Speed set point can be set to the desired value. Manual Speed set point should have a maximum value equal to the Maximum Compressor Speed set point for that circuit.

Fan Staging Deadbands

Fan Stage Deadband settings will only be visible if Fan VFD Configuration is set to None or 1st Fan VFD. The condenser fan staging deadbands have different default values based on the Fan VFD Configuration set point. When that set point is changed, a set of default values for the fan staging deadbands is loaded as shown.

Table 44: Fan VFD Configuration = None

| Set Point | Default Value Loaded |
|---------------------------|----------------------|
| Fan Stage Up Deadband 0 | 4°C (7.2°F) |
| Fan Stage Up Deadband 1 | 5°C (9°F) |
| Fan Stage Up Deadband 2 | 5.5°C (9.9°F) |
| Fan Stage Up Deadband 3 | 6°C (10.8°F) |
| Fan Stage Up Deadband 4 | 6.5°C (11.7°F) |
| Fan Stage Up Deadband 5 | 6.5°C (11.7°F) |
| Fan Stage Down Deadband 1 | 10°C (18°F) |
| Fan Stage Down Deadband 2 | 8°C (14.4°F) |
| Fan Stage Down Deadband 3 | 5.5°C (9.9°F) |
| Fan Stage Down Deadband 4 | 4°C (7.2°F) |
| Fan Stage Down Deadband 5 | 4°C (7.2°F) |

Table 45: Fan VFD Configuration = 1st Fan VFD

| Set Point | Default Value Loaded |
|---------------------------|----------------------|
| Fan Stage Up Deadband 0 | 2.5°C (4.5°F) |
| Fan Stage Up Deadband 1 | 2.5°C (4.5°F) |
| Fan Stage Up Deadband 2 | 4°C (7.2°F) |
| Fan Stage Up Deadband 3 | 5°C (9°F) |
| Fan Stage Up Deadband 4 | 4°C (7.2°F) |
| Fan Stage Up Deadband 5 | 4°C (7.2°F) |
| Fan Stage Down Deadband 1 | 4°C (7.2°F) |
| Fan Stage Down Deadband 2 | 3.5°C (6.3°F) |
| Fan Stage Down Deadband 3 | 3°C (5.4°F) |
| Fan Stage Down Deadband 4 | 2.5°C (4.5°F) |
| Fan Stage Down Deadband 5 | 2.5°C (4.5°F) |

Circuit Test Mode Set Points

Circuit test mode set points can be changed when either the unit mode is Test, or the circuit mode is Test. When neither the unit nor the circuit are in Test mode, all the circuit test mode set points for the circuit are automatically changed back to their 'off' values.

| Description | Default | Range |
|---------------------------------------|----------------|--------------|
| Test 100% VR Solenoid Output | Off | Off, On |
| Test 75% VR Solenoid Output | Off | Off, On |
| Test 50% VR Solenoid Output | Off | Off, On |
| Test Liquid Line Solenoid Output | Off | Off, On |
| Test Liquid Injection Solenoid Output | Off | Off, On |
| Test Evaporator EXV Position | 0% | 0 to 100% |
| Test Economizer EXV Position | 0% | 0 to 100% |
| Test Condenser Fan Output 1 | Off | Off, On |
| Test Condenser Fan Output 2 | Off | Off, On |
| Test Condenser Fan Output 3 | Off | Off, On |
| Test Condenser Fan Output 4 | Off | Off, On |
| Test Condenser Fan Output 5 | Off | Off, On |
| Test Condenser Fan Output 6 | Off | Off, On |
| Test Condenser Fan VFD Speed | 0% | 0 to 100% |

NOTE: Settings for outputs should be available based on the selected unit configuration settings.

Calculations

Evaporator

Error

LWT Error = Evaporator LWT - Active LWT Set Point

Slope

The slope represents the change or trend in either EWT or LWT over a time frame of one minute. It is calculated by taking readings of the temperature every 10 seconds and subtracting them from the previous value, over a rolling one minute interval.

Pulldown Rate

A pulldown rate is calculated by inverting the slope value and limiting to a minimum value of 0°C/min.

Unit

Capacity

The unit capacity is the total of the circuit target capacities divided by the number of circuits.

Total Power

An estimate of the total unit power is calculated by adding the power estimate for each circuit. All values are in units of kW.

Unit Enable

Enabling and disabling the chiller is accomplished using set points and inputs to the chiller. The Unit Switch, Remote Switch Input, and Unit Enable Set Point are all required to be On/Enable for the unit to be enabled when the control source is set to Local. The same is true if the control source is set to Network, with the additional requirement that the BAS Enable set point be Enable.

Table 42: Enable Combinations

| Unit Switch | Control Source Set Point | Remote Switch Input | Unit Enable Set Point | BAS Enable Set Point | Unit State |
|-------------|--------------------------|---------------------|-----------------------|----------------------|------------|
| Off | - | - | - | - | Disable |
| - | - | - | Disable | - | Disable |
| - | - | Disable | - | - | Disable |
| On | Local | Enable | Enable | - | Enable |
| - | Network | - | - | Disable | Disable |
| On | Network | Enable | Enable | Enable | Enable |

NOTE: A “-” indicates that the value is ignored.

All of the methods for disabling the chiller, discussed in this section, will cause a normal shutdown of any running circuits.

When the controller is powered up, the Unit Enable Set Point will be initialized to Disable if the Unit Enable Initial Set Point is set to Disable. The chiller will remain disabled after powering up until the Unit Enable Set Point is set to Enable.

Unit Mode Selection

The operating mode of the unit is determined by set points and inputs to the chiller. The Available Modes set point determines what modes of operation can be used. This set point also determines whether the unit is configured for glycol use. The Control Source set point determines where a command to change modes will come from. The Mode Switch digital input switches between cool mode and ice mode if they are available and the control source is set to Local. The BAS mode request switches between cool mode and ice mode if they are both available and the control source is set to Network.

The Available Modes Set Point should only be changed when the unit switch is off. This is to avoid changing modes of operation inadvertently while the chiller is running.

Unit Mode is set according to the following table.

Table 43: Unit Mode Combinations

| Available Modes Set Point | Control Source Set Point | Mode Switch | BAS Request | Unit Mode |
|---------------------------|--------------------------|-------------|-------------|-----------|
| Cool | - | - | - | Cool |
| Cool/Ice | Local | Off | - | Cool |
| Cool/Ice | Local | On | - | Ice |
| Cool/Ice | Network | - | Cool | Cool |
| Cool/Ice | Network | - | Ice | Ice |
| Ice | - | - | - | Ice |

NOTE: A “-” Indicates that the value is ignored.

Glycol Configuration

If the Available Modes set point is set to an option “w/Glycol,” then Evaporator Glycol set point must be selected as Yes. Glycol operation opens up the ranges for several set points to allow lower values.

Unit Control States

The unit will always be in one of three states:

1. Off – Unit is not enabled to run.
2. Auto – Unit is enabled to run.
3. Pumpdown – Unit is doing a normal shutdown.

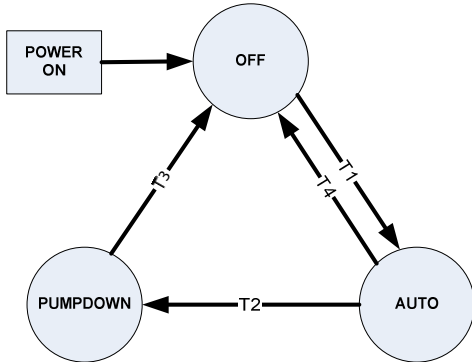

T1 - Off to Auto. All of the following are required:

- Unit is enabled
- No unit alarm requiring shutdown is active
- At least one circuit is enabled to start
- If unit mode = Ice, Ice Delay is not active
- Low Ambient Lockout is not active
- Basic unit configuration is complete
- Control system has rebooted since configuration changed
- If Cond Fan Config = All Fan VFD, DC controller = Auto

T2 - Auto to Pumpdown. Any of the following are required:

- Unit is disabled
- Unit Mode = Ice and LWT target is reached
- Unit alarm requiring normal shutdown is active
- Low Ambient Lockout is active

T3 - Pumpdown to Off. Any of the following are required:

- Unit alarm requiring normal shutdown is active
- All circuits complete pumpdown
- Cond Fan Config = All Fan VFD, DC controller = Auto

T4 - Auto to Off. Any of the following are required:

- Unit alarm requiring normal shutdown is active
- No circuits enabled and all circuits in Off state

Unit Status

Unit Status is displayed to indicate the general condition of the unit. The following table lists the text displayed for each unit status and the conditions that enable each status. If more than one status is enabled at the same time, the highest numbered status overrides the others and is displayed.

Table 44: Unit Status Conditions

| Enum | Status | Conditions |
|------|------------------------|---|
| 1 | Auto | Unit State = Auto |
| 2 | Auto: Sound Reduction | Unit State = Auto and Sound Reduction is active |
| 3 | Off: Ice Mode Timer | Unit State = Off, Unit Mode = Ice, and Ice Delay = Active |
| 4 | Off: Low OAT Lockout | Unit State = Off and Low OAT Lockout is active |
| 5 | Off DC not ready | Unit State = Off, Condenser Fan Configuration = All Fan VFD, and DC controller is not in auto control |
| 6 | Off: All Cir Disabled | Unit State = Off and all circuits unavailable to start (temporary conditions are not considered) |
| 7 | Off: Unit Alarm | Unit State = Off and manual reset Unit Alarm active |
| 8 | Off: Keypad Disable | Unit State = Off and Unit Enable Set Point = Disable |
| 9 | Off: Remote Switch | Unit State = Off and Remote Switch input is off |
| 10 | Off: BAS Disable | Unit State = Off, Control Source = Network, and BAS Enable = false |
| 11 | Off: Unit Switch | Unit State = Off and Unit Switch input is off |
| 12 | Off: Test Mode | Unit State = Off and Unit Test Mode = On |
| 13 | Auto: Wait for Load | Unit State = Auto, no circuits running, and LWT is less than the active set point + startup delta |
| 14 | Auto: Evap Recirculate | Unit State = Auto and Evaporator State = Start |
| 15 | Auto: Wait for flow | Unit State = Auto, Evaporator State = Start, and Flow Switch input is off |
| 16 | Auto: Pumpdown | Unit State = Pumpdown |
| 17 | Auto: Max Circuit Run | Unit State = Auto, Unit Mode = Cool, number of running circuits is limited by the Max Cir Run set point |
| 18 | Auto: Unit Cap Limit | Unit State = Auto, unit capacity limit has been met or exceeded |
| 19 | Auto: RapidRestore | Unit State = Auto, unit is performing RapidRestore operation |
| 20 | Off: Invalid Config | The unit configuration is not a valid combination or not complete. |
| 21 | Off: Cfg Chg, Rst Ctlr | Unit configuration set point has changed, and reboot of controller is required |

Ice Mode Start Delay

An adjustable start-to-start Ice Cycle Delay timer will limit the frequency with which the chiller may start in Ice Mode. The timer starts when the first compressor starts while the unit is in Ice Mode. While this timer is active, the chiller cannot restart in Ice Mode. The time delay is user adjustable. The Ice Cycle Delay timer may be manually cleared to force a restart in Ice Mode. A set point specifically for clearing the Ice Cycle Delay is available, Clear Ice Delay. Cycling controller power will also clear the timer.

Low Ambient Lockout

The operation of the chiller in response to OAT dropping below the Low OAT Lockout set point is configurable if the Fan VFD Configuration set point is set to 1st Fan VFD or All Fan VFD. In that case, there are three options:

- Lockout and Stop – chiller will shut down and lockout
- Lockout only – chiller does not shut down running circuits, will lock out circuits that are off
- Disabled – chiller does not shut down or lock out

If the Fan VFD Configuration set point is set to None, there is no configuration and the chiller will always operate according to the first option shown above. Descriptions of the operation for each option are in the following sections.

Lockout and Stop Operation

If the OAT drops below the low ambient lockout set point and the OAT sensor fault is not active, then low ambient lockout is triggered. The unit will go into the pumpdown state if any circuits are running. If no circuits are running the unit will go directly into the off state. Once all circuits complete pumpdown, the unit will remain in the off state until the lockout has cleared. This condition will clear when OAT rises to the lockout set point plus 2.5°C (4.5°F).

Lockout Only Operation

If OAT drops below the low ambient lockout set point and any circuits are running, then those circuits will be allowed to remain running and the unit will not enter the low ambient lockout condition. Circuits that are not running will enter a circuit level lockout condition when OAT drops below the lockout set point. This condition will clear at the circuit level when OAT rises to the lockout set point plus 2.5°C (4.5°F).

If the OAT is below the low ambient lockout set point, the OAT sensor fault is not active, and no circuits are running, then low ambient lockout is triggered. The unit will go directly into the off state and will remain in the off state until the lockout has cleared. This condition will clear when OAT rises to the lockout set point plus 2.5°C (4.5°F).

Disabled Operation

When low ambient lockout is disabled, the unit will not enter the low ambient lockout condition or shut down any running circuits, regardless of the OAT.

BAS Annunciation

Low Ambient Lockout is not an alarm, but it can be annunciated to the BAS as if it is one. When the Low OAT Lockout BAS Alert set point is set to On and the low ambient lockout is active, the following will occur:

- Chiller alarm status parameter will show alarm state
- Active Problem Alarm Code will be set to 16642 (assuming no higher code is active)
- Active Problem Alarm Index will be set to 65 (assuming no higher index is active)
- Digital parameter AmbTempLow will show alarm state
- Intrinsic alarming will show low ambient temperature via the LowOATemp object

Evaporator Pump Control

Only one source can be in control of the pumps at any given time. Three evaporator pump control states for control of the evaporator pumps:

1. Off - No pump on.
2. Start – Pump is on, water loop is being recirculated.
3. Run – Pump is on, water loop has been recirculated, and circuits can start if needed.

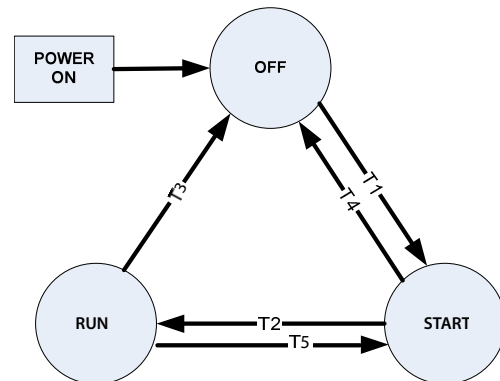

T1 - Off to Start - All of the following are required:

- Unit state = Auto
- Freeze protection started

T2 - Start to Run - Requires the following to be true:

- Flow ok for time longer than evaporator recirculate time set point

T3 - Run to Off - Requires all of the following to be true:

- Unit state = Off
- Freeze protection not active

T4 - Start to Off. - Requires all of the following to be true:

- Unit state = Off
- Freeze protection not active

T5 - Run to Start. - Requires the following to be true:

- Flow switch input is low for longer than the flow proof set point

Freeze Protection

To protect the evaporator from freezing, the evaporator pump will start if the manual reset flow loss alarm is not active and either of the following are true:

- LWT equal to or less than the Evap Freeze set point for at least three seconds and LWT sensor fault is not active
- EWT equal to or less than the Evap Freeze set point for at least three seconds and EWT sensor fault is not active

Freeze protection will end when manual reset flow loss alarm is active or all of the following are true:

- LWT is at least 1.11°C (2°F) above the Evap Freeze set point or LWT sensor fault is active
- EWT is at least 1.11°C (2°F) above the Evap Freeze set point or EWT sensor fault is active
- Pump has been running for at least 15 minutes

Pump Selection

The pump output used when evaporator state is Run will be determined by Evap Pump Control set point. This setting allows the following configurations:

- #1 only – Pump 1 will always be used
- #2 only – Pump 2 will always be used
- Auto – The primary pump is the one with the least run hours, the other is used as a backup
- #1 Primary – Pump 1 is used normally, with pump 2 as a backup
- #2 Primary – Pump 2 is used normally, with pump 1 as a backup

Primary/Standby Pump Staging

The pump designated as primary will start first. If the evaporator state is Start for a time greater than the recirculate timeout set point and there is no flow, then the primary pump will shut off and the standby pump will start. When the evaporator is in the run state, if flow is lost for more than half of the Flow Loss Delay set point value, the primary pump will shut off and the standby pump will start. Once the standby pump is started, the flow loss alarm logic will apply if flow cannot be established in the evaporator start state, or if flow is lost in the evaporator run state.

Auto Control

If auto pump control is selected, the primary/standby logic above is still used. When the evaporator is not in the run state, the run hours of the pumps will be compared. The pump with the least hours will be designated as the primary at this time.

Leaving Water Temp (LWT) Reset

LWT Target

The evaporator LWT Target varies based on settings and inputs and is selected as follows:

Table 45: LWT Targets Control Source

| Available Modes Set Point | Control Source Set Point | Mode Switch | BAS Mode Command | BAS LWT Target |
|---------------------------|--------------------------|-------------|------------------|--------------------|
| Cool | Local | - | - | Cool LWT Set Point |
| Cool | Network | - | - | BAS Cool Set Point |
| Cool/Ice | Local | Off | - | Cool LWT Set Point |
| Cool/Ice | Local | On | - | Ice LWT Set Point |
| Cool/Ice | Network | - | Cool | BAS Cool Set Point |
| Cool/Ice | Network | - | Ice | BAS Ice Set Point |
| Ice | Local | - | - | Ice LWT Set Point |
| Ice | Network | - | - | BAS Ice Set Point |

The base LWT target may be reset to a higher value if the unit is in Cool Mode and it is configured for a reset. The type of reset to be used is determined by the LWT Reset Type set point.

When the active reset increases, the Active LWT Target is changed at a rate of 0.1°C (0.18°F) every 10 seconds. When the active reset decreases, the Active LWT Target is changed all at once.

After resets are applied, the LWT target can never exceed a value of 21.12°C (70°F). Since the Cool LWT set point can be set as high as 21.12°C, the amount of reset may be limited in order to meet this requirement to clamp the active LWT target to 21.12°C.

Reset Type – None

The Active LWT target is set equal to the base LWT target.

4-20 mA External Signal Reset

The Active LWT target is adjusted by the 4-20 mA reset analog input. Parameters used:

1. Max Reset set point
2. LWT Reset signal

Reset is 0 if the reset signal is less than or equal to 4 mA. Reset is equal to the Max Reset Delta T set point if the reset signal equals or exceeds 20 mA. The amount of reset will vary linearly between these extremes if the reset signal is between 4 mA and 20 mA. An example of the operation of 4-20 mA reset in Cool Mode follows.

Figure 78: 4-20 mA Reset - Cool Mode

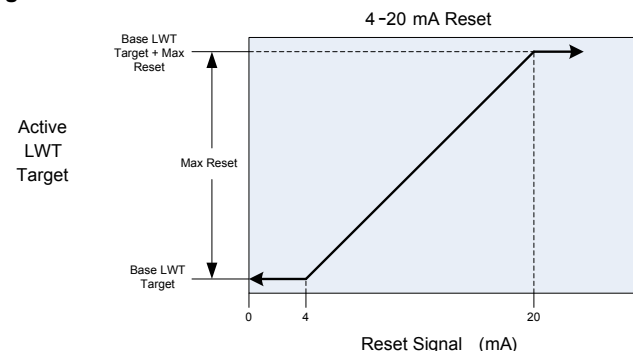

Unit Capacity Control

Unit capacity control will be performed as described in this section. A combination of starting/stopping compressors and loading/unloading compressors is used to control the overall unit capacity.

Maximum Circuits Running

If the number of compressors running is equal to the Max Circuits Running set point, no additional compressors should be started. This applies in both Cool Mode and Ice Mode operation.

When both circuits are running and the Max Circuits Running set point is changed to one, a circuit should shut down.

Cool Mode Operation

In Cool Mode, unit capacity is adjusted via circuit staging and capacity changes on each circuit. LWT error and EWT pulldown rate are the primary factors in unit capacity adjustments. This section details all the logic for unit capacity control in Cool Mode.

Staging Sequence

This section defines which circuit is the next one to start or stop if the logic does not call for simultaneous start or stop of both circuits. In general, circuits with fewer starts will normally start first, and circuits with more run hours will normally stop first. Staging sequence can also be determined by an operator defined sequence via set points.

The next circuit to start must meet the following requirements:

Lowest sequence number of those circuits available to start

- if sequence numbers are equal, it must have the least starts
- if starts are equal, it must have least run hours
- if run hours are equal, it must be the lowest numbered circuit

The next circuit to shut down must meet the following requirements:

Lowest sequence number of the circuits that are running

- if sequence numbers are equal, it must have the most run hours
- if run hours are equal, it must have the least starts
- if starts are equal, it must be the lowest numbered circuit

Load/Unload Sequence

This section defines which circuit is the next one to load or unload if the logic does not call for simultaneous load or unload of both circuits.

The next circuit to load must meet the following requirements:

Lowest capacity of the running circuits

- if capacities are equal, it must have the lowest sequence number of the circuits that are running
- if the sequence numbers are equal, it must have the least

starts

- if starts are equal, it must have the least run hours
- if run hours are equal, it must be the lowest numbered circuit

The next compressor to unload must meet the following requirements:

Highest capacity of the running compressors

- if capacities are equal, it must have the lowest sequence number of the compressors that are running
- if sequence numbers are equal, it must have the most run hours
- if run hours are equal, it must have the least starts
- if starts are equal, it must be the lowest numbered compressor

Stage Up Delay

Any time the number of running circuits changes, the stage up delay will start and run for a time equivalent to the Stage Up Delay set point.

Any time there are no circuits running, the stage up delay will be cleared.

For the purpose of this section, a “running” circuit is a circuit in the Preopen, Start, or Run state.

Staging Circuits On

Unit capacity control will command at least one circuit to start if all of the following are true:

- Unit State = Auto
- Evaporator Pump State = Run
- LWT error > Startup Delta T set point
- Pulldown Hold is not active

Both circuits are able to start at the same time if the following conditions are true (in addition to the above conditions):

- Demand limit > 40% if Demand Limit = Enable
- Network limit set point > 40% if Control Source = Network

If one circuit is running, unit capacity control will command the second circuit to start if all of the following are true:

- One circuit running at full capacity (see circuit details for determination of full capacity)
- Stage Up Delay has completed
- LWT Error > Stage Up Delta T set point
- Capacity Increase command is active
- Max Number Circuits Running set point = 2

Staging Circuits Off

Unit capacity control will command a single circuit to shut down if both circuits are running and any of the following are true:

- LWT error < - (Stage Down Delta T set point)
- LWT error < Stage Up Delta T set point, both circuits speed < Light Load Stage Down set point, and neither circuit has an active capacity hold event
- A unit capacity limit is active, both circuits capacity < Light Load Stage Down set point, and neither circuit has an active capacity hold event
- Max Number Circuit Running set point changes to 1

If one circuit is running the capacity control logic will command it to shut down if the following conditions are true for 15 minutes:

- Compressor running at 14 Hz
- LWT Error < -0.4°C

Unit capacity control will command all circuits to shut down if LWT Error < - (Shut Down Delta T set point).

Circuit Capacity Change Commands

Load commands are issued when the following are true:

- LWT Error > Load Deadband
- Time > Load Delay has passed since the last unit capacity increase
- EWT Pulldown Rate Hold is not active

Unload commands are issued when:

- Either LWT Error < - (Unload Deadband), or EWT Pulldown Rate Unload is active
- Time > Load Delay has passed since the last unit capacity decrease

Load Balancing

In Cool Mode, capacity of the circuits is controlled so that when possible their capacities are balanced. Circuits will generally maintain a capacity imbalance that does not exceed 15%.

If a capacity change has not occurred for at least one minute and the difference in capacity between the two running circuits is more than 15%, then the circuit capacities will be adjusted. The circuit at the lower capacity will load and the circuit at the higher capacity will unload simultaneously.

If either circuit is running in manual capacity control or running with active capacity limiting events, then no load balancing adjustments will be made.

Ice Mode Operation

In Ice Mode, running circuits will load up simultaneously at the maximum possible rate that allows for stable operation of the individual circuits.

Staging Of Circuits

Both circuits should start when LWT error is greater than the Startup Delta T set point and the Max Circuits Running set point is set to 2. If only one circuit can start, the other circuit should start as soon as possible after the stage up delay has expired.

Both circuits should be staged off when LWT error is 0 or less.

Unit Capacity Limits

Unit capacity limits are used to limit total unit capacity in Cool Mode only. Multiple limits may be active at any time, and the lowest limit is always used in the unit capacity control.

Soft load, demand limit, and network limit use a deadband around the actual limit value, such that unit capacity increase is not allowed within this deadband. If unit capacity is above the deadband, capacity is decreased until it is back within the deadband, which is 8%.

The unit capacity will be adjusted as needed via circuit staging and capacity changes to meet the lowest active limit, but the last running compressor cannot be turned off to meet a limit lower than the minimum unit capacity.

Demand Limit

The maximum unit capacity can be limited by a 4-20 mA signal on the Demand Limit analog input at the unit controller. This function is only enabled if the Demand Limit set point is set to ON.

As the signal varies from 4 mA up to 20 mA, the maximum unit capacity changes from 100% to 0%.

Network Limit

The maximum unit capacity can be limited by a network command. This function is only enabled if the unit control source is set to Network. The signal will be received through the BAS interface on the unit controller.

This network limit command directly sets a maximum unit capacity from 0% to 100%.

RapidRestore®

The option allows the capability to restart more quickly and to load faster than normal when power is lost and restored.

Enabling

Changing the RapidRestore® set point to Enable will require the following to be true:

- RapidRestore® module is present at address 22
- DI1 on the RapidRestore® module has a signal

If any of the above are no longer true, the RapidRestore® set point will be changed to Disable.

Operation Following Cycling of Power

The chiller will enter RapidRestore® upon powering up when the following conditions are met:

- RapidRestore® is enabled
- Power failure lasts less than the value of the Max Power Failure Time set point
- Power failure lasts at least one second
- Unit is enabled
- LWT Error is at least equal to the Stage Up Delta T set point

RapidRestore® will end if any of the following conditions occur:

- LWT Error is less than the Stage Up Delta T set point
- Unit capacity = 100%
- All circuits become disabled for any reason
- Unit becomes disabled for any reason
- 10 minutes have passed since unit powered up

Unit Level Changes

During RapidRestore® operation, unit capacity control logic allows both circuits to start simultaneously.

In the event that both circuits do not start simultaneously, the requirement for the running circuit to reach maximum capacity will be ignored for staging the other circuit on.

Circuit Level Changes

When RapidRestore® is triggered, all compressor cycle timers are cleared to allow for starting more quickly. The limit of four starts per hour will remain in effect and will not be cleared by triggering RapidRestore®.

Circuit Functions

Components controlled at the circuit level include:

- Compressor VFD
- Compressor VR Solenoid Valves
- Evaporator EXV
- Economizer EXV
- Liquid Line Solenoid Valve
- Liquid Injection Solenoid Valve
- Condenser Fans

Calculations

Calculations are for each circuit.

Approach Values

Evaporator Approach = LWT – Evap Saturated Temp

Condenser Approach = Cond Saturated Temp – OAT

Superheat Values

Suction superheat = Suction Temp – Evap Saturated Temp

Discharge superheat = Discharge Temp – Cond Saturated Temp

Economizer Superheat = Econ Temp – Econ Saturated Temp

Differential Pressure Values

Oil Pressure Differential = Cond Pressure - Oil Pressure

Pressure Difference = Cond Pressure – Evap Pressure

Pressure Ratio

Pressure Ratio = (Cond Press + 101.325) ÷ (Evap Press + 101.325)

Feedback Capacity

Feedback capacity is a representation of the actual capacity as a percentage of full capacity based on feedback regarding the actual speed of the compressor.

Compressors vary capacity via changes to the speed. The actual compressor speed is read from the VFD. Feedback capacity for a compressor with a VFD is:

$$\text{Actual Compressor Speed} \times 100 \div \text{Maximum Speed}$$

Saturated Condenser Temperature Limit

The maximum saturated condenser temperature calculation is based on the compressor operational envelope. This value is used for triggering high condenser pressure alarms and as a reference for the trigger values of the high pressure hold and unload events. Chiller software is designed to calculate a dynamic maximum saturated condenser temperature. High saturated condenser hold and unload offset values are described as follows.

Table 46: Saturated Condenser Temperature Conditions

| Condition | Saturated Evap Temp or LWT | Max Cond Saturated Temp (°C) |
|-------------------------------------|----------------------------|------------------------------|
| EXV state is Start Pressure Control | LWT ≤ 0°C | 1.589 X LWT + 68.3 |
| | LWT > 0°C | 68.3 |
| EXV state is SSH or MOP Control | Te ≤ 0°C | 1.589 X Te + 68.3 |
| | Te > 0°C | 68.3 |
| All other conditions | n/a | 68.3 |

High Saturated Condenser – Hold Value

High Cond Hold Value = Max Saturated Cond Value – High Cond Press Hold Offset set point

High Saturated Condenser – Unload Value

High Cond Unload Value = Max Saturated Cond Value – High Cond Press Unload Offset set point

High Motor Current Limits

Max Motor Current = Minimum of (VFD Rated Current, Motor Rated Current)

where:

- VFD Rated Current is read from the compressor VFD
- Motor Rated Current is determined by the compressor type and the voltage configuration:

| Compressor Type | Motor Rated Current (Amps) | | | |
|-----------------|----------------------------|-------|-------|-------|
| | 380V | 400V | 460V | 575V |
| F3ALVVR60 | 222.8 | 222.8 | 183.3 | 167.0 |
| F3ALVVR86 | 375.6 | 375.6 | 311 | 253.5 |
| F3BLVVR86 | 527.9 | 527.9 | 434.1 | N/A |
| F4ALVVR80 | 692.1 | 692.1 | 574.8 | N/A |

Pumpdown Target Value

The pressure target for pumpdown when the circuit enters the pumpdown state is selected as follows:

If Service Pumpdown set point = Disable

Then Pumpdown Target = Evaporator Pressure at pumpdown start – 20 kPa with value limited to the range from 35 kPa to the Pumpdown Pressure Max set point

If Service Pumpdown set point = Enable

Then Pumpdown Target = 35 kPa

Circuit Availability

A circuit is available to start if the following conditions are true:

- Circuit switch input is on
- No manual reset circuit fault alarms are active
- Circuit Mode set point is set to Enable
- BAS Circuit Mode set point is set to Auto
- No cycle timers are active
- Oil Sump Check = Ready

Oil Sump Check

Oil sump check is to make sure that oil in the sump is of sufficient quality prior to starting the compressor.

Oil sump check is set to Ready when

$Discharge\ Temperature > Saturated\ Oil\ Temperature + 5^{\circ}C$

Oil sump check is set to Not Ready when

$Discharge\ Temperature < Saturated\ Oil\ Temperature + 4.5^{\circ}C$

Circuit States

There are five distinct states of control for the circuit as shown.

Figure 79: Circuit State Transitions

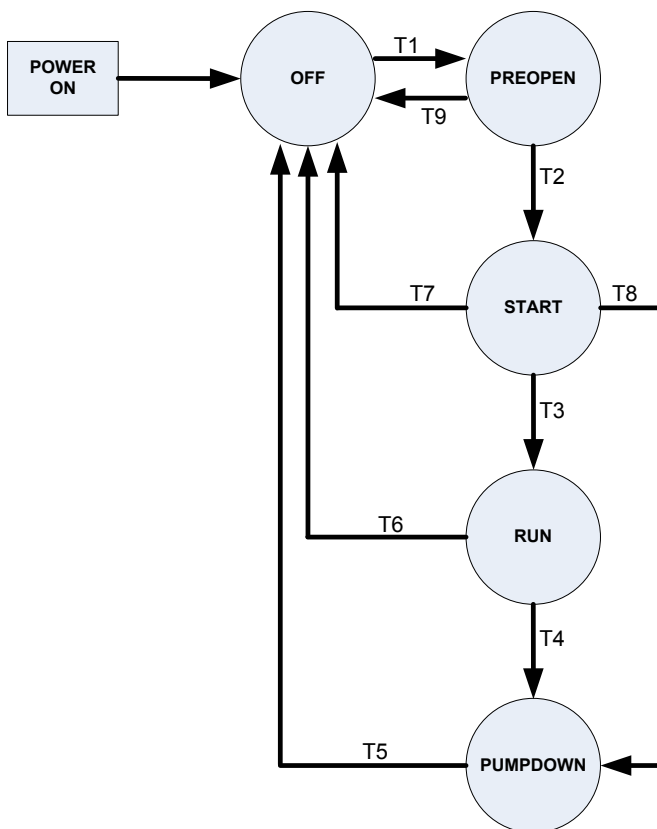

T1 – Off to Preopen - All of the following are required:

- Circuit is available to start per the previous section
- Adequate pressure in the evaporator and condenser (see No Pressure At Start Alarm)
- Unit capacity control logic requires the circuit to start

T2 – Preopen to Start

Evaporator EXV completes preopen operation.

T3 – Start to Run

Compressor speed ≥ 19 Hz for at least 30 seconds

T4 – Run to Pumpdown - Any of the following are required:

- Unit capacity control logic requires this circuit to stop
- Unit state is pumpdown
- A pumpdown alarm occurs on the circuit
- Circuit switch input is off
- Control Source = Network and BAS Circuit Mode = Off

T5 – Pumpdown to Off - Any of the following are required:

- Evaporator Pressure drops below Pumpdown Target Value
- Circuit state has been pump down for longer than the Pumpdown Time Limit set point
- Unit state is Off
- Rapid stop alarm occurs on the circuit

T6 – Run to Off - Any of the following are required:

- Unit state is Off
- Rapid stop alarm occurs on the circuit

T7 – Start to Off - Any of the following are required:

- Unit state is Off
- Rapid stop alarm occurs on the circuit

T8 – Start to Pumpdown - Any of the following are required:

- Unit capacity control logic requires this circuit to stop
- Unit state is pumpdown
- A pumpdown alarm occurs on the circuit
- Circuit switch is open
- Control Source = Network and BAS Circuit Mode = Off

T9 – Preopen to Off - Any of the following are required:

- Unit state is Off
- A rapid stop alarm occurs on the circuit
- A pumpdown alarm occurs on the circuit
- Circuit switch input is off
- Control Source = Network and BAS Circuit Mode = Off

Circuit Status

Circuit Status is displayed to indicate the general condition of the circuit. The following table lists the text displayed for each circuit status and the conditions that enable each status. If more than one status is enabled at the same time, the highest numbered status overrides the others and is displayed.

Table 47: Circuit Status

| Enum | Status | Conditions |
|------|------------------------|---|
| 1 | Off:Ready | Circuit is ready to start when needed |
| 2 | Off:Cycle Timer | Circuit is off & cannot start due to active cycle timer |
| 3 | Off:OAT Low | Circuit is off & cannot start due to low ambient lockout |
| 4 | Off: Max Starts Per Hr | Circuit is off & cannot start due to exceeding 4 starts/hr |
| 5 | Off:BAS Disable | Circuit is off & cannot start due to BAS Circuit Mode input being set to Off |
| 6 | Off:Keypad Disable | Circuit is off & cannot start due to Circuit Mode set point on HMI is set to Disable |
| 7 | Off:Circuit Switch | Circuit is off & circuit switch is off |
| 8 | Off:Oil Heating | Circuit is off & Oil Sump Check = Not Ready |
| 9 | Off:Alarm | Circuit is off & cannot start due to active circuit alarm |
| 10 | Off:Test Mode | Circuit is in test mode |
| 11 | EXV Preopen | Circuit is in preopen state |
| 12 | Run:Pumpdown | Circuit is in pumpdown state |
| 13 | Run:Normal | Circuit is in run state & running normally |
| 14 | Run:Evap Press Low | Circuit is in start or run state & cannot load due to low evaporator pressure |
| 15 | Run:Cond Press High | Circuit is in start or run state & cannot load due to high condenser pressure |
| 16 | Run:VFD Current High | Circuit is in start or run state & cannot load due to high VFD line current |
| 17 | Run:VFD Temp High | Circuit is in start or run state & cannot load due to high VFD temperature |
| 18 | Run:Motor Current High | Circuit is in start or run state & cannot load due to high motor current |
| 19 | Run:High LWT Limit | Circuit is in start or run state & cannot load due to the evaporator LWT exceeding the limit for allowing full capacity |

Compressor Control

The compressor is controlled via:

- a digital output to give the run command to compressor VFD
- a modbus speed command to control compressor speed
- digital outputs for compressor VR solenoids to control VR
- a digital output for liquid injection to the compressor

Run Command Output

The compressor run command output should be on when the circuit state is Start, Run, or Pumpdown. It should be off when the circuit state is Off or Preopen.

Cycle Timers

A minimum time must pass between starts of each compressor. When the compressor starts, a timer starts which will run for a time determined by the Start-Start Timer set point.

A minimum time must pass between the stop and start of each compressor. When the compressor stops, a timer starts which will run for a time determined by the Stop-Start Timer set point.

While either timer is running, the compressor cannot start. Both cycle timers will be enforced even through cycling of power to the chiller. These timers may be cleared via the Clear Cycle Timers set point.

Starts Per Hour Limit

In addition to the cycle timers, a limit of four starts per hour is enforced. A buffer of start times for the last four starts is maintained. If the current time is an hour or less after the first timestamp in the buffer, the next start will be delayed.

This limit is cleared if the Clear Cycle Timers set point is set to Yes.

Capacity Control

The compressor will vary capacity via changes to the motor speed (frequency).

Auto Capacity Control

The normal speed change is 1 Hz for all compressor configurations.

Circuit State = Off - Speed command is 0 Hz.

Circuit State = Preopen - Speed command is set to the minimum for the configuration.

Circuit State = Start - Immediately after starting, the compressor speed will be set to the minimum for the configuration and held there while circuit state is Start.

Circuit State = Run - After the circuit enters the Run state, changes to the speed are performed based on load and unload commands coming from the unit capacity control logic (see unit capacity control section). The speed is constrained to a range from the minimum based on the configuration up to the Compressor Maximum Speed set point.

When a capacity increase occurs, a time delay starts; and when a capacity decrease occurs, a separate time delay starts. While either of these delays is active, no normal capacity changes will occur. The load and unload delay times are calculated values.

Circuit State = Pumpdown - Speed command will drop 2 Hz every second until reaching the minimum for the configuration.

Manual Speed Control

The speed of the compressor may be controlled manually. Manual speed control is enabled via a set point with choices of Auto or Manual. Another set point allows setting the compressor speed. However, the resulting compressor speed is still limited to the range from the minimum speed based on configuration up to the Compressor Maximum Speed set point.

The compressor speed will be stepped up or down until it is equal to the speed that corresponds to the manual speed set point. Changes to the speed will be made as fast as allowed by the calculated load and unload delays. Speed control may be set to Manual only when circuit state is Start or Run.

Capacity control shall revert back to automatic control if either:

- the circuit state changes from Start or Run to another state
- capacity control has been set to Manual for four hours

Load and Unload Delay

LWT Error determines the delays for load and unload commands.

Table 48: Load and Unload Delay Conditions

| LWT Error | Delay |
|---|--|
| LWT Error > Startup Delta T set point | Load command delay is 5 seconds |
| 0.1°C ≤ LWT Error ≤ Startup Delta T set point | Load command delay will vary from 5 seconds to 10 seconds |
| – (Stage Down Delta T set point) ≤ LWT Error ≤ -0.1°C | Unload command delay will vary from 3 seconds to 6 seconds |
| LWT Error < -(Stage Down Delta T set point) | Unload command delay is 3 seconds |

VR Solenoid Valve Control

There are three solenoid valves for changing volume ratio of the compressor:

- 50 VR solenoid valve
- 75 VR solenoid valve
- 100 VR solenoid valve

The compressor should start with all three solenoid valves off. After compressor has been running for at least 20 seconds, the control logic will “stage” the solenoid valves. Table 49 shows which VR solenoid valves are on at each stage as well as stage up and stage down conditions. These staging conditions must be active for 30 seconds to trigger each stage up or down.

Table 49: VR Solenoid Valve Control Stages

| Stage | VR | 50 VR SV | 75 VR SV | 100 VR SV | Stage Up Condition | Stage Down Condition |
|-------|-----|----------|----------|-----------|-----------------------|-----------------------|
| 0 | 1.6 | Off | Off | Off | Pressure Ratio > 2.10 | n/a |
| 1 | 1.8 | On | Off | Off | Pressure Ratio > 2.85 | Pressure Ratio < 1.90 |
| 2 | 2.4 | Off | On | Off | Pressure Ratio > 3.85 | Pressure Ratio < 2.65 |
| 3 | 3.1 | On | On | On | n/a | Pressure Ratio < 3.65 |

When the circuit state becomes Pumpdown or Off, all VR solenoids should be turned off.

Condenser Fan Control

Condenser fan control will vary in operation based on the Fan VFD Configuration set point.

Table 50: Condenser Fan Control Configurations

| Fan VFD Configuration | Control Type | Control Mechanism |
|-----------------------|---|------------------------------|
| None | Staging only | Contactors |
| 1st Fan VFD | Staging and speed control of 1st fan on the circuit | Contactors and VFD |
| All Fan VFD | Staging and speed control of all fans | Integrated VFD on each motor |

Physical Fan Layout

Fans are numbered as shown below (top view of chiller). Fan numbers start on the left side of the circuit, closest to the control box when facing the control box.

Circuit #1 fans start at 101 and can run through 116 depending on the number of fans on the circuit. Circuit #2 fans start at 201 and can run through 214 depending on the number of fans on the circuit.

Figure 80: Fan Numbering Diagram - Representative

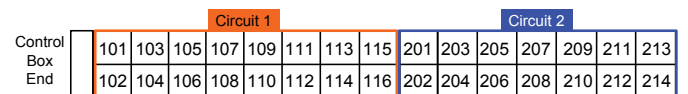

NOTE: Number of fans vary by unit configuration

Condenser Fan Control State

There are only two control states: Off and Condensing Temperature Control.

When the circuit state is Off or Preopen, condenser fan control will be in the Off state. All fans will be off.

When circuit state is Start, Run, or Pumpdown, the condenser fan control will be in the Condensing Temperature Control state. Fan staging and speed will be controlled as needed to drive the saturated condenser temperature to the target.

Saturated Condenser Temp Target

There are two purposes to have a variable condenser saturated temperature target:

- a. Maintain pressure difference and pressure ratio above low limit for compressor to run within operational envelope
- b. Achieve best performance at various conditions

The target value is displayed on the controller screen and is

equal to the base target, but also constrained to a calculated range defined by the Minimum Target value and Maximum Target value.

Base Target

$$\text{Base Target } (^\circ\text{C}) = 0.979264 \times \text{OAT} + 10.7$$

Minimum Target Value

Minimum Target value is designed to keep the compressor in its operational envelope. This value is calculated by the controller based on the pressure difference, pressure ratio and fan stage down deadband.

First 10 minutes after compressor start, the minimum target is 38°C (100.4°F).

After the first 10 minutes, the minimum target range is gradually decreased to the calculated value at a rate of 0.1°C/sec.

Fan Control – No VFD or 1st Fan VFD

Fans On Each Digital Output

The tables below show which fan numbers are on each of the fan digital outputs.

Table 51: Fan Numbers for Each Fan Digital Output

| Circuit 1 | | | | | | | | |
|--------------|---|---|---------|---------|---------|-------------|-----------------|-----------------|
| # Fans | 4 | 6 | 8 | 10 | 12 | 14 | 16 | |
| Fan Output # | 1 | - | 101 | 101 | 101 | 101 | 101 | |
| | 2 | - | 102 | 102 | 102 | 102 | 102 | |
| | 3 | - | 103 | 103 | 103,105 | 103,105 | 103,105 | 103,105 |
| | 4 | - | 104,106 | 104 | 104,106 | 104,106 | 104,106 | 104,106,107,108 |
| | 5 | - | 105 | 105,107 | 107,109 | 107,109,111 | 107,109,111,113 | 109,111,113,115 |
| | 6 | - | - | 106,108 | 108,110 | 108,110,112 | 108,110,112,114 | 110,112,114,116 |

| Circuit 2 | | | | | | | | |
|--------------|---|-----|---------|---------|---------|-------------|-----------------|---|
| # Fans | 4 | 6 | 8 | 10 | 12 | 14 | 16 | |
| Fan Output # | 1 | 201 | 201 | 201 | 201 | 201 | - | |
| | 2 | 202 | 202 | 202 | 202 | 202 | - | |
| | 3 | 203 | 203 | 203 | 203,205 | 203,205 | 203,205 | - |
| | 4 | 204 | 204,206 | 204 | 204,206 | 204,206 | 204,206 | - |
| | 5 | - | 205 | 105,107 | 207,209 | 207,209,211 | 207,209,211,213 | - |
| | 6 | - | - | 106,108 | 208,210 | 208,210,212 | 208,210,212,214 | - |

Fan Outputs Per Fan Stage

The table below shows which digital outputs are energized for each stage.

Table 52: Digital Outputs Energized for Each Stage

| # Fans On Circuit | 4 | 6 | 8 | 10 | 12 | 14 | 16 |
|-------------------|---------|-----------|-------------|-------------|-------------|-------------|-------------|
| 0 | 0 | 0 | 0 | 0 | 0 | 0 | 0 |
| 1 | 1 | 1 | 1 | 1 | 1 | 1 | 1 |
| 2 | 1,3 | 1,3 | 1,3 | 1,2 | 1,2 | 1,2 | 1,2 |
| 3 | 1,2,3 | 1,3,5 | 1,5 | 1,3 | 1,3 | 1,3 | 1,3 |
| 4 | 1,2,3,4 | 1,2,3,5 | 1,3,5 | 1,2,3 | 1,5 | 1,2,3 | 1,2,3 |
| 5 | - | 1,3,4,5 | 1,2,3,5 | 1,3,5 | 1,2,5 | 1,5 | 1,5 |
| 6 | - | 1,2,3,4,5 | 1,2,3,4,5 | 1,2,3,5 | 1,3,5 | 1,2,5 | 1,2,5 |
| 7 | - | - | 1,2,3,5,6 | 1,3,4,5 | 1,2,3,5 | 1,3,5 | 1,3,5 |
| 8 | - | - | 1,2,3,4,5,6 | 1,2,3,4,5 | 1,3,4,5 | 1,2,3,5 | 1,2,3,5 |
| 9 | - | - | - | 1,3,4,5,6 | 1,2,3,4,5 | 1,3,4,5 | 1,4,5 |
| 10 | - | - | - | 1,2,3,4,5,6 | 1,2,3,5,6 | 1,2,3,4,5 | 1,2,4,5 |
| 11 | - | - | - | - | 1,3,4,5,6 | 1,3,5,6 | 1,3,4,5 |
| 12 | - | - | - | - | 1,2,3,4,5,6 | 1,2,3,5,6 | 1,2,3,4,5 |
| 13 | - | - | - | - | - | 1,3,4,5,6 | 1,4,5,6 |
| 14 | - | - | - | - | - | 1,2,3,4,5,6 | 1,2,4,5,6 |
| 15 | - | - | - | - | - | - | 1,3,4,5,6 |
| 16 | - | - | - | - | - | - | 1,2,3,4,5,6 |

Staging Concept

As long as the condenser saturated temperature is within the band defined by the active stage up deadband and active stage down deadband, the fan stage will not change. When saturated condenser temperature is outside of the deadbands, error is accumulated and will cause a change in the fan stage.

Figure 81: Fan Staging Conditions

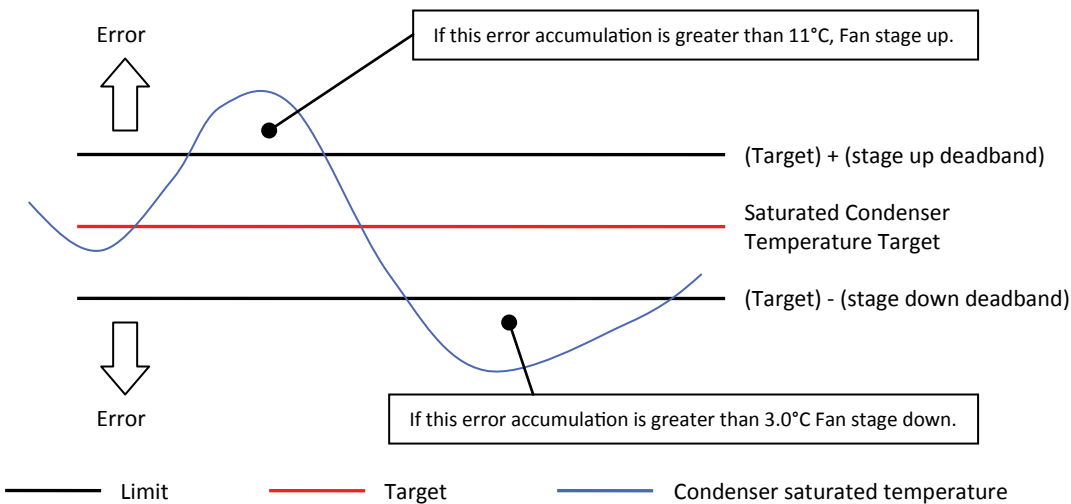

Staging Up

When the saturated condenser temperature is above the Target + the active deadband, a Stage Up error is accumulated.

$$\text{Stage Up Error Step} = \text{saturated condenser temperature} - (\text{target} + \text{Stage Up Deadband})$$

The Stage Up Error Step is added to Stage Up Accumulator once every five seconds, only if the saturated condenser temperature is not falling. When the Stage Up Error Accumulator is greater than 11°C (19.8°F) fan stage is increased by 1. When a stage up occurs or the saturated condenser temperature falls back within the Stage Up deadband the Stage Up Accumulator is reset to zero.

The first fan will turn on when condenser saturated temperature is above the target rather than using the error accumulator.

Staging Down

When the saturated condenser refrigerant temperature is below the Target – the active deadband, a Stage Down error is accumulated.

$$\text{Stage Down Error Step} = (\text{target} - \text{Stage Down deadband}) - \text{saturated condenser temperature}$$

The Stage Down Error Step is added to Stage Down Accumulator once every 5 seconds. When the Stage Down Error Accumulator is greater than 3°C (5.4°F), a fan stage is removed.

When a stage down occurs or the saturated condenser temperature rises back within the Stage Down deadband the Stage Down Error Accumulator is reset to zero.

Active Deadbands

Stage Up and Stage Down deadbands are determined by set points as shown in the following table:

Table 53: Stage Deadbands

| Fan stage | Stage Up Setting | Stage Down Setting |
|-----------|-------------------------|---------------------------|
| 0 | Fan Stage Up Deadband 0 | --- |
| 1 | Fan Stage Up Deadband 1 | Fan Stage Down Deadband 1 |
| 2 | Fan Stage Up Deadband 2 | Fan Stage Down Deadband 2 |
| 3 | Fan Stage Up Deadband 3 | Fan Stage Down Deadband 3 |
| 4 | Fan Stage Up Deadband 4 | Fan Stage Down Deadband 4 |
| 5 to 16 | Fan Stage Up Deadband 5 | Fan Stage Down Deadband 5 |

VFD on 1st Fan of Each Circuit

As an option, the first fan may be driven by a VFD. The VFD control will vary the fan speed to drive the saturated condenser temperature to a target value. The target value is normally the same as the saturated condenser temperature target.

VFD Speed Control

The VFD speed should always be 0% when the fan stage is 0. When the fan stage is greater than 0, the VFD speed will be calculated to control the saturated condenser temperature to the VFD target. The minimum and maximum speed are set by the VFD Min Speed and VFD Max Speed set points.

Stage Up Compensation

In order to create a smoother transition when the fan stage increases, the VFD compensates by slowing down initially. This is accomplished by adding the new fan stage up deadband to the VFD target. The higher target causes the VFD logic to decrease fan speed. Then, every 2 seconds, 0.1°C (0.18°F) is subtracted from the VFD target until it is equal to the saturated condenser temperature target set point.

Speed Signal to VFD

The fan VFD is controlled using a 0-10 volt signal. When the fan should be off, the signal will be 0 Vdc. When the fan should be running, the signal will vary based on the percent speed calculation.

$$\text{Speed Signal} = \text{Percent Speed} / 10$$

Fan Control In Water Side Econ State

Fan control when the cooling state is Water Side Econ includes fan staging and fan VFD control. The general concept is to stage fans to control Water Side Economizer capacity and trim the capacity with the fan VFD speeds. During Water Side Econ state, if a circuit is disabled then it should not run the fans for Water Side Economizer.

If transition from Hybrid Cooling to Water Side Econ occurs, it is ok for fans to start staging on during pumpdown of running circuit(s).

During Water Side Econ mode operation, the unit will change to control the chilled fluid setpoint based on the evaporator entering fluid sensor rather than the leaving sensor. Since the evaporator is not producing any cooling effect in this mode, the evaporator entering fluid temperature sensor is representative of the leaving fluid temperature the system will see.

Fan Control In Hybrid Cooling Modulation State

Fans on a circuit with a running compressor should operate the same as they normally do in Mechanical Cooling Only (based on condenser pressure control).

Fans on a circuit NOT running the compressor should all be turned on if that circuit is enabled to run (but not all at once) upon entering the Hybrid Cooling Modulation state. After the cooling state is Hybrid Cooling Modulation for five minutes the fans on a circuit not running the compressor can start turning on. A minimum of 20 seconds should pass between fan stage increases and it should only increase if LWT Error is within the dead band calculated for unloading the running compressor. These requirements ensure the running compressor is given a chance to unload in compensation for adding Water Side Economizer capacity.

Fan Control - All Fans with VFD

If Fan VFD Configuration is set to All Fan VFD, different control logic will be used. All fan motors are DC fan motors which have integrated inverters and are controlled via modbus. This configuration requires the DC Fan Controller.

System Architecture

Architecture of the control system components involved in control of the DC fan motors is shown below. Data flows in both directions on the communication link as well as the Modbus connection.

Figure 82: Controller Communication Architecture

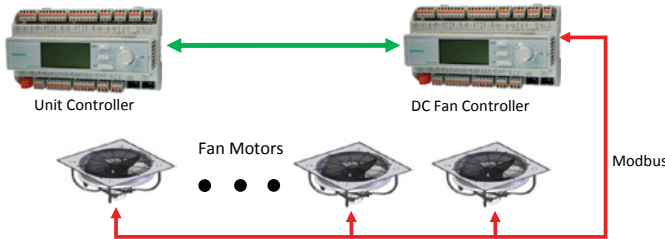

The following control logic will reside in the DC Fan Controller:

- Automatic control
- Alarm handling per individual fan motor
- Fan motor addressing process
- Fan motor testing control

Normal Control

When Control Mode is set to Auto, the logic in this section will automatically control the DC fan motors for normal chiller operation.

The VFD speed should always be 0% when the fan stage is 0. When the fan stage is greater than 0, the VFD speed will be calculated to control the saturated condenser temperature to the VFD target.

Speed Command To Motors

All fan motors will be sent a speed command via modbus. The speed command is in units of rpm with 800 rpm corresponding to 100% and will vary based on the percent speed calculation.

$$\text{Speed Command} = \text{Percent Speed Calculation} \times 8$$

Normally the same speed command is sent to all motors on a circuit.

Staging

Calculated RPM is a value used in the fan staging logic.

When the circuit run flag is 0, the fan stage is always 0. Once the fan stage is more than 0, it will not be allowed to drop back to 0 until the circuit run flag is 0.

The maximum fan stage is equal to the number of fans on the circuit. When fan stage is 0, it will be set to the maximum fan

stage when the PI (proportional integral) loop reaches 100%. This does not occur any time other than when the fan stage is 0.

Test Mode Control

When Control Mode is set to Test, the fan motors can be manually controlled for test purposes.

The test settings allow selecting values from 0% to 100%. When the test setting for a fan is set to 12.5% or higher, the speed command corresponding to the test setting will be sent and the run command will be sent to the fan.

$$\text{Speed Command} = \text{Test setting} \times 8$$

When Control Mode is no longer set to Test, the following actions should occur:

- all the test settings set back to 0%
- stop command sent to all motors
- speed command of 0 rpm sent to all motors

Evaporator EXV Control

This section outlines the positioning logic for the Evaporator EXV, which is the EXV installed in the liquid line feeding the evaporator.

- EXV will initially be positioned to control evaporator pressure
- EXV will normally be positioned to control SSH (suction superheat)
- SSH target will vary based on DSH (discharge superheat)
- In some conditions, EXV will be positioned to control evaporator pressure to keep all parameters within operating envelope

There are five EXV control states:

- Closed – EXV is closing or in the closed position
- Preopen – EXV is opening prior to compressor start
- Start Pressure Control – EXV is controlling to pressure target after compressor start
- SSH Control – EXV is controlling suction superheat
- MOP Control – EXV is controlling to maximum operating pressure for compressor

Closed State

If the unit is configured without liquid line solenoid valves, the EXV position should be 0% any time the EXV is in a closed state. The 0% position command also causes the evaporator EXV module driver to re-initialize the valve to the zero position.

If the unit is configured with liquid line solenoid valves, the EXV position should be 0% when the EXV initially enters the closed state, while it is re-initializing to the zero position. After the EXV position command has been 0% for one minute, the EXV should be moved to 5% to prevent excessive pressure buildup between the EXV and liquid line solenoid valve.

Preopen Operation

When the EXV state is Preopen, the EXV position command will be 30%.

Pressure Control State

In Start Pressure Control, the EXV is positioned to control the evaporator pressure to a target.

Pressure Target

The pressure target is calculated based on evaporator LWT, then limits are applied to keep the target in an acceptable range.

The base target value varies from 65 kPa to 420 kPa as LWT varies from -5°C to 30°C.

Figure 83: Evaporator EXV Pressure Target

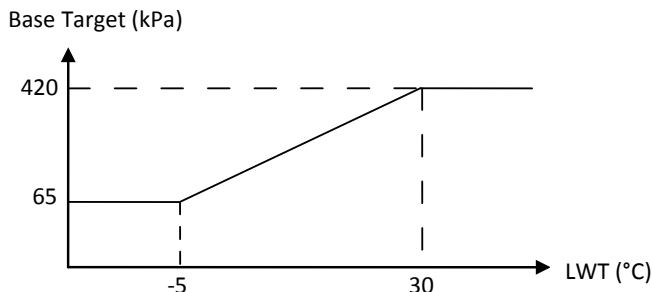

This base target is then limited to a range as defined by the Minimum Limit and Maximum Limit shown below:

- Minimum Limit = Low Pressure Hold set point + 25 kPa
- Maximum Limit = $\text{Min} \{(\text{Cond Pr} + 101.325) / 1.7 - 101.325, \text{Cond Pr} - 180\}$
- If Maximum Limit < Minimum Limit, then Pressure Target = Minimum Limit

MOP Control State

In MOP (Maximum Operating Pressure) Control, the EXV is positioned to control the evaporator pressure to a target.

MOP Target

The MOP Target is $\text{Min} \{450, (\text{Cond Pr} + 101.325) / 1.7 - 101.325, \text{Cond Pr} - 180\}$.

Superheat Control State

In superheat control, the EXV is positioned to control suction superheat (SSH) to the SSH Target.

SSH Target

The SSH target varies linearly based on discharge superheat (DSH). This target is updated every 10 seconds and averaged over a 100 second period (with sampling every 10 seconds).

Evaporator EXV Suction Superheat Target

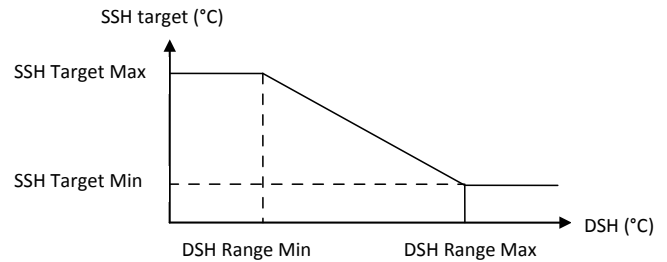

When the EXV transitions to the superheat control state, the target will ramp up or down until it meets the calculated SSH target.

- If $\text{SSH Target Min} \leq \text{current SSH} \leq \text{SSH Target Max}$, the target will start at the current SSH value and increase or decrease by 0.1°C every 10 seconds until it meets calculated SSH target.
- If $\text{current SSH} > \text{SSH Target Max}$, the target value will start ramping from SSH Target Max. Then the target will decrease by 0.1°C every 10 seconds until it meets calculated SSH target.
- If $\text{current SSH} < \text{SSH Target Min}$, the target value will start ramping from SSH Target Min. Then the target will increase by 0.1°C every 10 seconds until it meets calculated SSH target.

Economizer EXV Control

The economizer circuit is activated and modulated using an EXV. This is an optional feature that will only be enabled if the Economizer Configuration set point is set to Yes. If the configuration set point is set to No, then the economizer position should remain 0%.

Control Concept

- EXV will be positioned using control algorithm
- Maintain DSH above requirements for compressor
- Maximize circuit performance at the operating conditions

EXV States

There are three economizer EXV states:

- Closed: EXV is closing or closed
- Purge: EXV is opening to release condensed liquid in a controlled manner
- Superheat: EXV is controlling economizer gas superheat

Operation – Closed State

The EXV position command should be 0% any time the EXV is in the closed state. The 0% position command also causes the EVD driver to re-initialize the valve to the zero position. After one minute, the EXV position command should be set to 25% open and remain there until the state changes.

Operation – Purge State

In the Purge state, the economizer EXV position is 0%.

Operation – Superheat Control State

In the Superheat control state, the EXV will be positioned to control economizer gas superheat.

Liquid Injection Solenoid Valve

As an option, the chiller can be equipped with liquid injection on the compressors. When configured with this option, the Liquid Injection Configuration setting should be set to Yes and the liquid injection solenoid valve outputs can be activated.

Liquid injection solenoid valve output is activated if both of the following are true:

- Circuit state is Run
- Discharge Temperature > Liquid Injection Activation set point

Liquid injection solenoid valve output will be turned off if either of the following are true:

- Discharge Temperature < Liquid Injection Activation set point - 15°C
- Circuit state is no longer Run

Liquid Line Solenoid Valve

As an option, the chiller can be equipped with liquid line solenoid valves. When configured with this option, the Liquid Line Solenoid Valve Configuration setting should be set to Yes.

If the chiller is configured with liquid line solenoid valves, the liquid line solenoid valve output should be activated when the circuit enters the Preopen state and remain on during the Start and Run states. The output should be turned off 10 seconds after the circuit enters the Pumpdown state or when the circuit state is Off.

Circuit Capacity Overrides

The following conditions override automatic capacity control as described. These overrides keep the circuit from entering a condition in which it is not designed to run.

High Water Temperature Capacity Limit

If the evaporator LWT is 25°C (77°F) or higher, the circuit capacity will be limited. If circuit capacity resulting from the next compressor speed increase is 81.5% or more, the circuit cannot increase in capacity.

If the circuit capacity is higher than 81.5%, the circuit will reduce capacity until it is at 81.5% or lower.

Once this limit is triggered, it will be in effect until evaporator LWT is less than 25°C (77°F) for at least one minute.

Situations may arise that require some action from the chiller, or that should be logged for future reference. The alarm digital output will be operated based on active alarm scenarios as shown in the table below.

| State | Scenario |
|----------|--|
| Off | No alarms preventing the chiller or an individual circuit from running |
| Blinking | One, and only one, circuit has an alarm preventing it from running |
| On | Unit alarm preventing chiller from running or both circuits have alarms preventing them from running |

For the Blinking state, the output should cycle five seconds on then five seconds off while the indicated scenario is active.

Alarm Logging

All alarms appear in the active alarm list while active. All alarms are added to the alarm log when triggered and when cleared. Entries in the log representing the occurrence of an alarm will be preceded by '+' while entries representing the clearing of an alarm will be preceded by '-'.

When an alarm occurs, the alarm type, date, and time are stored in the active alarm buffer corresponding to that alarm (viewed on the Alarm Active screens), and also in the alarm history buffer (viewed on the Alarm Log screens). The active alarm buffers hold a record of all current alarms.

The alarm log can be exported to a formatted SD card in the controller. A setting called "Alarm Log Export" will be used to initiate this when set to Yes. The exported log will be saved in a text file on the SD card with each line representing an entry in the log. Only what is in the actual alarm log will be saved to the file when the export was initiated.

Signaling Alarms

The following actions will signal that an alarm has occurred:

- The unit or circuit executes a rapid or pumpdown shutoff.
- An alarm bell icon will be displayed in the upper right-hand corner of all controller screens, including the optional remote user interface panel's screens.
- An optional field supplied and wired remote alarm device will be activated.

Clearing Alarms/Faults

Active alarms can be cleared through the keypad/display or a BAS network. Alarms are automatically cleared when controller power is cycled. Alarms are cleared only if the conditions required to initiate the alarm no longer exist. All alarms and groups of alarms can be cleared via the keypad or network via LON using nviClearAlarms and via BACnet using the ClearAlarms object.

To use the keypad, follow the Alarm links to the Alarms screen, which will show Active Alarms and Alarm Log. Select Active Alarm and press the wheel to view the Alarm List (list of current active alarms). They are in order with the most recent on top. The second line on the screen shows Alm Cnt (number of alarms currently active) and the status of the alarm clear function. An active password is not necessary to clear alarms.

If the problem(s) causing the alarm have been corrected, the alarms will be cleared, disappear from the Active Alarm list and be posted in the Alarm Log. If not corrected, the On will immediately change back to OFF and the unit will remain in the alarm condition.

Description of Alarms

Details for each alarm are listed in a table format as shown below. The table below explains each row in the tables.

| | |
|-----------------|---|
| Alarm: | Description of the alarm |
| Displayed Text: | Text displayed on HMI in the alarm lists |
| Trigger: | Conditions required to trigger the alarm |
| Action Taken: | Actions that should be taken when the alarm triggers |
| Reset: | Method by which the alarm can be cleared and conditions required for doing so, if any |

Unit Alarms

Unit GFP Fault

| | |
|-----------------|---|
| Alarm: | Unit GFP Fault |
| Displayed Text: | Unit Ground Fault |
| Trigger: | All of the following are true: <ul style="list-style-type: none"> • Ground Fault Protection Option set point = Single Point • GFP Relay 1 input is off for 1 second |
| Action Taken: | Rapid shutdown all circuits and lock out unit from running |
| Reset: | Auto reset when GFP Relay 1 input is on for 5 seconds |

Circuit 1 GFP Fault

| | |
|-----------------|---|
| Alarm: | Circuit 1 GFP Fault |
| Displayed Text: | C1 Ground Fault |
| Trigger: | All of the following are true: <ul style="list-style-type: none"> • Ground Fault Protection Option set point = Multi Point • GFP Relay 1 input is off for 1 sec |
| Action Taken: | Rapid shutdown all circuits and lockout unit from running. |
| Reset: | Auto reset when GFP Relay 1 input is on for 5 seconds |

Circuit 2 GFP Fault

| | |
|-----------------|---|
| Alarm: | Circuit 2 GFP Fault |
| Displayed Text: | C2 Ground Fault |
| Trigger: | All of the following are true: <ul style="list-style-type: none"> • Ground Fault Protection Option set point = Multi Point • GFP Relay 2 input is off for 1 sec |
| Action Taken: | Rapid shutdown all circuits and lockout unit from running. |
| Reset: | Auto reset when GFP Relay 2 input is on for 5 seconds |

Evaporator Flow Loss

| | |
|-----------------|---|
| Alarm: | Evaporator Flow Loss |
| Displayed Text: | Evap Water Flow Loss |
| Trigger: | <p>1: Evap Pump State = Run AND Evap Flow Digital Input = No Flow for time > Flow Proof set point AND at least one circuit is not in the Off state</p> <p>2: Evap Pump State = Start for time greater than Recirculate Timeout set point and all pumps have been tried and Evap Flow Digital Input = No Flow</p> |
| Action Taken: | <p>Rapid shutdown all circuits and:</p> <ul style="list-style-type: none"> -if an auto reset occurrence has triggered, keep unit enabled and allow the evaporator recirculation sequence to proceed -if a manual reset occurrence has been triggered, lock out unit from running |
| Reset: | <p>This alarm can be cleared at any time manually via the keypad or via the BAS clear alarm command.</p> <p>If active via trigger condition 1:</p> <p>When the alarm occurs due to this trigger, it can auto reset the first two times each day, with the third occurrence being manual reset. When the auto reset occurrences are triggered, the unit will remain enabled to run (rather than going to an off state).</p> <p>For the auto reset occurrences, the alarm will reset automatically when the evaporator state is Run again. This means the alarm stays active while the unit waits for flow, then it goes through the recirculation process after flow is detected. Once the recirculation is complete, the evaporator goes to the Run state which will clear the alarm. After three occurrences, the count of occurrences is reset and the cycle starts over if the manual reset flow loss alarm is cleared.</p> <p>If active via trigger condition 2:</p> <p>If the flow loss alarm has occurred due to this trigger, it is always a manual reset alarm.</p> |

Evaporator Water Freeze Protect

| | |
|-----------------|---|
| Alarm: | Evaporator Water Freeze Protect |
| Displayed Text: | Evap Water Freeze |
| Trigger: | Evaporator LWT or EWT equal to or less than Evaporator Freeze Protect set point for a time at least as long as the evaporator recirculation time. If the sensor fault is active for either LWT or EWT, then that sensor value cannot trigger the alarm. |
| Action Taken: | Rapid shutdown all circuits and lock out unit from running |
| Reset: | This alarm can be cleared manually via the keypad, but only if evaporator LWT and EWT are both above the Evaporator Freeze Protect set point or have a sensor fault (meaning the temperature reading is not valid). |

Evaporator Water Temperatures Inverted

| | |
|-----------------|---|
| Alarm: | Evaporator Water Temperatures Inverted |
| Displayed Text: | EvapWaterTempInverted |
| Trigger: | <p>All of the following are true for at least 60 seconds:</p> <ul style="list-style-type: none"> • Evap EWT < Evap LWT – 1°C • at least one circuit is in Start or Run state • EWT sensor fault not active • LWT sensor fault not active |
| Action Taken: | Normal shutdown all circuits and lock out unit from running |
| Reset: | This alarm can be cleared manually via the keypad or via BAS command. |

Evaporator LWT Sensor Fault

| | |
|-----------------|---|
| Alarm: | Evaporator LWT Sensor Fault |
| Displayed Text: | Evap LWT SenFault |
| Trigger: | <p>If any of the following occur for more than one second:</p> <ul style="list-style-type: none"> • Resistance value is < 340 Ω • Resistance value is > 300 kΩ • Reliability value reported for input is anything other than 'NoFault' |
| Action Taken: | Rapid shutdown all circuits and lock out unit from running |
| Reset: | <p>This alarm can be cleared manually via the keypad or BAS command if the following are true for at least 5 seconds:</p> <ul style="list-style-type: none"> • Resistance value is from 340 Ω to 300 kΩ • Reliability value reported for input is 'NoFault' |

Evaporator EWT Sensor Fault

| | |
|-----------------|--|
| Alarm: | Evaporator EWT Sensor Fault |
| Displayed Text: | Evap EWT SenFault |
| Trigger: | If any of the following occur for more than one second: <ul style="list-style-type: none"> Resistance value is < 340 Ω Resistance value is > 300 kΩ Reliability value reported for input is anything other than 'NoFault' |
| Action Taken: | Normal shutdown all circuits and lock out unit from running |
| Reset: | This alarm can be cleared manually via the keypad or BAS command if the following are true for at least 5 seconds: <ul style="list-style-type: none"> Resistance value is from 340 Ω to 300 kΩ Reliability value reported for input is 'NoFault' |

OAT Sensor Fault

| | |
|-----------------|---|
| Alarm: | OAT Sensor Fault |
| Displayed Text: | OAT SenFault |
| Trigger: | If any of the following occur for more than one second: <ul style="list-style-type: none"> Resistance value is < 340 Ω Resistance value is > 300 kΩ Reliability value reported for input is anything other than 'NoFault' |
| Action Taken: | Normal shutdown all circuits and lock out unit from running |
| Reset: | This alarm can be cleared manually via the keypad or BAS command if the following are true for at least five seconds: <ul style="list-style-type: none"> Resistance value is from 340 Ω to 300 kΩ Reliability value reported for input is 'NoFault' |

External Alarm

| | |
|-----------------|--|
| Alarm: | External Alarm |
| Displayed Text: | External Alarm |
| Trigger: | External alarm input is open for at least 1 second. |
| Action Taken: | Rapid shutdown all circuits and lock out unit from running |
| Reset: | Auto clear when external alarm input is closed for five seconds. |

Emergency Stop

| | |
|-----------------|---|
| Alarm: | Emergency Stop |
| Displayed Text: | Emergency Stop Switch |
| Trigger: | Emergency Stop input off for 1 second |
| Action Taken: | Rapid shutdown all circuits and lock out unit from running |
| Reset: | This alarm can be cleared manually via the keypad or via BAS command after the emergency switch input is on for five seconds. |

AC Module Comm Failure

| | |
|-----------------|---|
| Alarm: | AC Module Comm Failure |
| Displayed Text: | AC Module Comm Fail |
| Trigger: | Communication with the module has failed. Specifically, this means the reliability value reported for the module is anything other than 0 for at least 3 seconds. |
| Action Taken: | Rapid shutdown all circuits and lock out unit from running |
| Reset: | This alarm can be cleared manually via the keypad or BAS command after reliability value reported for the module is 0 for at least five seconds. |

Evaporator EXV Module Comm Failure

| | |
|-----------------|---|
| Alarm: | Evaporator EXV Module Comm Failure |
| Displayed Text: | EvapExvModCommFail |
| Trigger: | When evaporator Expansion Valve Type is set as E6V model number (see Table 35), communication with the EVD module called EEXV1 has failed. Specifically, this means that 10 consecutive failures of read/write command blocks for this modbus address have occurred. |
| Action Taken: | Rapid shutdown all circuits and lock out unit from running |
| Reset: | This alarm can be cleared manually via the keypad or BAS command after communication is restored for at least five seconds. |

DC Fan Controller Comm Failure

| | |
|-----------------|--|
| Alarm: | DC Fan Controller Comm Failure |
| Displayed Text: | DcFanCtrlCommFail |
| Trigger: | Condenser Fan VFD Configuration set point is set to All Fan VFD and heartbeat from DC fan controller is not received for 30 seconds. |
| Action Taken: | Normal shutdown all circuits and lock out unit from running |
| Reset: | This alarm can be cleared manually via the keypad or BAS command if heartbeat from DC fan controller has been received in the last 30 seconds. |

Evaporator Pump #1 Failure

| | |
|-----------------|---|
| Alarm: | Evaporator Pump #1 Failure |
| Displayed Text: | Evap Pump 1 Fault |
| Trigger: | Unit is configured with primary and backup pumps, pump #1 is running, and the pump control logic switches to pump #2. |
| Action Taken: | Backup pump is used |
| Reset: | This alarm can be cleared manually via the keypad or BAS command. |

Evaporator Pump #2 Failure

| | |
|-----------------|---|
| Alarm: | Evaporator Pump #2 Failure |
| Displayed Text: | Evap Pump 2 Fault |
| Trigger: | Unit is configured with primary and backup pumps, pump #2 is running, and the pump control logic switches to pump #1. |
| Action Taken: | Backup pump is used |
| Reset: | This alarm can be cleared manually via the keypad or BAS command. |

Bad Demand Limit Input

| | |
|-----------------|---|
| Alarm: | Bad Demand Limit Input |
| Displayed Text: | Bad Demand Lim Input |
| Trigger: | Demand limit input out of range and Demand Limit set point is set to On. For this alarm, out of range is considered to be a signal less than 3 mA or more than 21 mA. |
| Action Taken: | Demand limit function and signal are ignored |
| Reset: | Auto clear when Demand Limit set point is set to Off or demand limit input back in range for 5 seconds. |

Bad LWT Reset Input

| | |
|-----------------|---|
| Alarm: | Bad LWT Reset Input |
| Displayed Text: | Bad LWT Reset Input |
| Trigger: | LWT Reset Type set point is 4-20 mA and LWT reset input out of range. For this alarm out of range is considered to be a signal less than 3 mA or more than 21 mA. |
| Action Taken: | LWT reset signal and 4-20 mA function are ignored |
| Reset: | Auto clear when LWT Reset Type set point is not 4-20 mA or LWT reset input back in range for five seconds. |

Economizer EXV Module Comm Failure

| | |
|-----------------|--|
| Alarm: | Economizer EXV Module Comm Failure |
| Displayed Text: | EconExvModCommFail |
| Trigger: | Economizer Configuration set point is set to Yes and communication with the economizer EXV module has failed. Specifically, this means that 16 consecutive failures of read/write command blocks for this address have occurred. |
| Action Taken: | Economizer valve command is set to 0% in control logic, though without communication the module is left to operate per logic embedded in it. It should be set up to automatically close the valves when communication is lost. |
| Reset: | This alarm can be cleared manually via the keypad or BAS command after communication is restored for at least 5 seconds. |

Water Side Economizer EWT Sensor Fault

| | |
|-----------------|--|
| Alarm: | Water Side Economizer EWT Sensor Fault |
| Displayed Text: | WSE EWT SenFault |
| Trigger: | If any of the following occur for more than one second: <ul style="list-style-type: none"> Resistance value is < 340 Ω Resistance value is > 300 kΩ Reliability value reported for input is anything other than 'NoFault' |
| Action Taken: | Cannot use water side economizer |
| Reset: | This alarm can be cleared manually via the keypad or BAS command if the following are true for at least 5 seconds: <ul style="list-style-type: none"> Resistance value is from 340 Ω to 300 kΩ Reliability value reported for input is 'NoFault' |

Water Side Economizer Valve Fault

| | |
|-----------------|---|
| Alarm: | Water Side Economizer Valve Fault |
| Displayed Text: | WSE Valve Fault |
| Trigger: | If the following conditions are true for 90 seconds the alarm should be triggered: <ul style="list-style-type: none"> WSE water valve 1 command = 100% WSE water valve 1 position < 90% Or, if the following conditions are true for 90 seconds the alarm should be triggered: <ul style="list-style-type: none"> WSE water valve 2 command = 0% WSE water valve 2 position > 10% |
| Action Taken: | Disable and lock out chiller from running |
| Reset: | This alarm can be cleared manually via the controller HMI or BAS command. |

Water Side Economizer Valve Problem

| | |
|-----------------|--|
| Alarm: | Water Side Economizer Valve Problem |
| Displayed Text: | WSE Valve Problem |
| Trigger: | <p>If the following conditions are true for 90 seconds the alarm should be triggered:</p> <ul style="list-style-type: none"> • WSE water valve 2 command = 100% • WSE water valve 2 position < 90% <p>Or if the following conditions are true for 90 seconds the alarm should be triggered:</p> <ul style="list-style-type: none"> • WSE water valve 1 command = 0% • WSE water valve 1 position > 10% |
| Action Taken: | Make Water Side Econ unavailable (can still operate in mechanical cooling state) |
| Reset: | This alarm can be cleared manually via the controller HMI or BAS command. |

Circuit Alarms

Low Evaporator Pressure

| | |
|---------------|--|
| Alarm: | Low Evaporator Pressure |
| Text: | Cn EvapPressLow |
| Trigger: | <p>When circuit state = Start and OAT ≥ -8°C, any of the following can trigger:</p> <ul style="list-style-type: none"> • Evap Pressure < 0 kPa for 5 seconds • Evap Pressure < -50 kPa for 2 seconds <p>When circuit state = Start and OAT < -8°C, any of the following can trigger:</p> <ul style="list-style-type: none"> • Evap Pressure < 0 kPa for 20 seconds • Evap Pressure < -50 kPa for 5 seconds <p>Note: for this condition where OAT is lower than -8°C, the first two times any of the trigger conditions are met in a day the circuit will only shut down and the alarm will not trigger. On the third occurrence in a day, the circuit will shut down and the alarm will be triggered.</p> <p>For first 5 minutes circuit state = Run, any of the following can trigger:</p> <ul style="list-style-type: none"> • Evap Pressure < 0 kPa for 5 seconds • Evap Pressure < -50 kPa for 2 seconds • Evap Pressure < Low Pressure Unload set point for 100 seconds <p>After circuit state = Run for 5 minutes, any of the following can trigger:</p> <ul style="list-style-type: none"> • Evap Pressure < 30 kPa for 5 seconds • Evap Pressure < -30 kPa for 2 seconds • Evap Pressure < Low Pressure Unload set point for time > Freeze Time <p>Where:</p> <ul style="list-style-type: none"> • Freeze Time = 70 – 0.906 x Freeze Error, limited to range of 20-70 seconds • Freeze Error = Low Evap Pressure Unload – Evap Pressure <p>For any trigger condition, the alarm cannot trigger if the evaporator pressure sensor fault is active.</p> |
| Action Taken: | Rapid shutdown of circuit and lock out from running |
| Reset: | This alarm can be cleared manually via the Unit Controller keypad. |

High Condenser Pressure

| | |
|-----------------|--|
| Alarm: | High Condenser Pressure |
| Displayed Text: | Cn CondPressHigh |
| Trigger: | Saturated Condenser Temp > Max Saturated Condenser Value for time longer than High Condenser Pressure Delay set point. |
| Action Taken: | Rapid shutdown of circuit and lock out from running |
| Reset: | This alarm can be cleared manually via the Unit Controller keypad if Saturated Condenser Temp < Max Saturated Condenser Value. |

Low Pressure Difference Or Ratio

| | |
|-----------------|---|
| Alarm: | Low Pressure Difference Or Ratio |
| Displayed Text: | Cn LowPrDiffOrRatio |
| Trigger: | This alarm is triggered on the third occurrence of the below conditions within two hours. Prior occurrences are events. |
| Trigger 1: | <p>Pressure ratio is < 1.6 for longer than the Low Pressure Diff/Ratio Delay set point after circuit state transition to Run. Pressure ratio is calculated as shown with pressures in kPa:</p> $Ratio = (Cond\ Press + 101.325) / (Evap\ Press + 101.325)$ |
| Trigger 2: | <p>Pressure difference is less than 180 kPa for longer than the Low Press Diff/Ratio Delay set point after circuit state transition to Run. Press difference is calculated as shown in kPa:</p> $Difference = (Cond\ Pressure) - (Evap\ Pressure)$ <p>Alarm/event cannot trigger for 5 minutes after circuit state transitions to Preopen if OAT < 7°C, however the trigger logic will still run during this window.</p> |
| Action Taken: | Rapid shutdown of circuit and lock out from running |
| Reset: | This alarm should auto reset every time until it has triggered 3 times within 2 hours and be cleared manually via Unit Controller keypad or BAS. |

Figure 84: Low Evaporator Pressure Fault Diagram

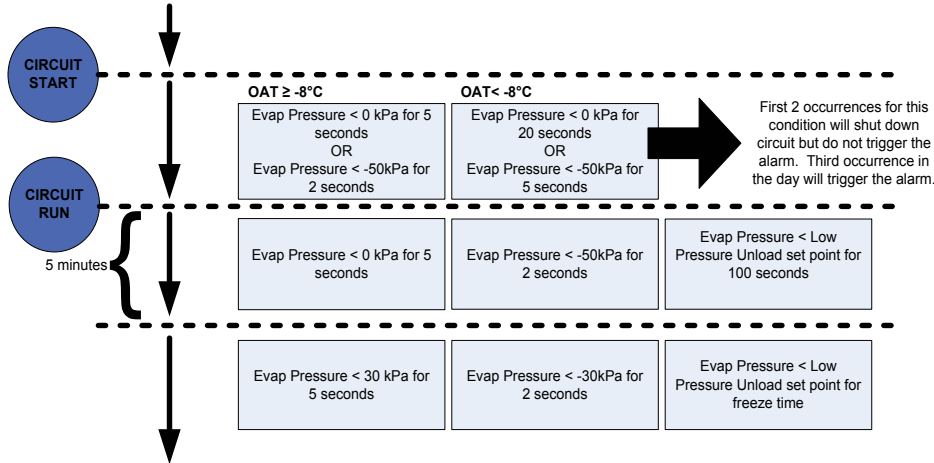

Mechanical High Pressure Switch

| | |
|-----------------|---|
| Alarm: | Mechanical High Pressure Switch |
| Displayed Text: | Cn MHP Switch |
| Trigger: | Compressor VFD reports Safe Disable Input alarm. This is the case when the alarm code reported by the VFD is either 003BH or 003CH. |
| Action Taken: | Rapid shutdown of circuit and lock out from running. Note that VFD will shut down compressor directly in response to this alarm in the VFD. Controller then needs to move circuit to the off state, but compressor should already be turned off by the VFD. |
| Reset: | This alarm can be cleared manually via the Unit Controller keypad after the VFD is no longer reporting the Safe Disable Input alarm. |

High Oil Pressure Drop

| | |
|-----------------|---|
| Alarm: | High Oil Pressure Drop |
| Displayed Text: | Cn Oil PD High |
| Trigger: | Circuit is in the Start or Run state and Oil Pressure Drop > High Oil Pressure Drop value for a time longer than High Oil Pressure Drop Delay set point. High Oil Pressure Drop value is calculated as shown below. <i>Operating PD = Condenser Pressure – Evaporator Pressure</i> <i>Minimum for High Oil Pressure Difference = High Oil Pressure Difference Minimum set point</i> <i>Maximum for High Oil Pressure Difference = High Oil Pressure Difference Minimum set point + 500 kPa</i> Note that the set point exists individually for each circuit. |
| Action Taken: | Rapid shutdown of circuit and lock out from running |
| Reset: | This alarm can be cleared manually via the Unit Controller keypad or via BAS command. |

High Discharge Temperature

| | |
|-----------------|--|
| Alarm: | High Discharge Temperature |
| Displayed Text: | Cn DiscTempHigh |
| Trigger: | The following are true for 5 seconds: <ul style="list-style-type: none"> Discharge Temp > High Discharge Temp set point Discharge temp sensor fault is not active |
| Action Taken: | Rapid shutdown of circuit and lock out from running |
| Reset: | This alarm can be cleared manually via the Unit Controller keypad or via BAS command when Discharge Temp is below the High Discharge Temp set point. |

Figure 85: High Oil Pressure Difference Values

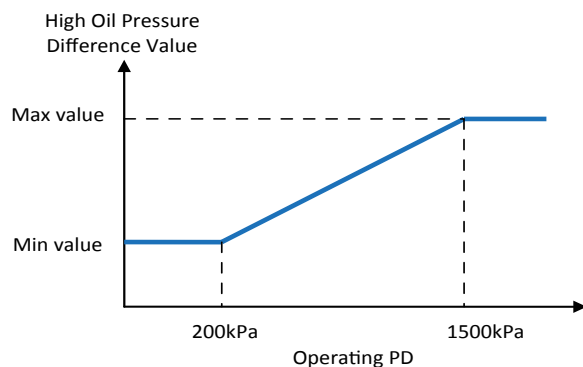

High Motor Temperature

| | |
|-----------------|--|
| Alarm: | High Motor Temperature |
| Displayed Text: | Cn Motor Temp High |
| Trigger: | Compressor VFD reports motor overheat fault. The fault code for this is 0020H. |
| Action Taken: | Rapid shutdown of circuit and lock out from running |
| Reset: | This alarm can be cleared manually via the Unit Controller keypad when compressor has been off for at least 5 minutes. When the alarm is cleared in the unit controller, the command to clear the fault in the VFD will be sent. |

Compressor Multiple Start Failure

| | |
|-----------------|--|
| Alarm: | Compressor Multiple Start Failure |
| Displayed Text: | Cn CompMultiStartFail |
| Trigger: | This alarm is triggered on the third occurrence of the below conditions within 2 hours. Prior occurrences are events. All of the following must be true to trigger: <ul style="list-style-type: none"> • Compressor Run command is on • Compressor VFD Communication Failure is not active • Either VFD Actual Speed = 0 for more than 15 seconds <u>or</u> VFD Actual Speed < 13 Hz for more than 30 seconds |
| Action Taken: | Rapid shutdown of circuit and lock out from running |
| Reset: | This alarm can be cleared manually via the Unit Controller keypad or via BAS command. |

No Pressure At Start

| | |
|-----------------|--|
| Alarm: | No Pressure At Start |
| Displayed Text: | Cn No Press At Start |
| Trigger: | All of the following must be true to trigger: <ul style="list-style-type: none"> • Circuit start requested • Condenser Fan VFD Configuration set point = None • Either Evaporator Pressure or Condenser Pressure are less than 35 kPa (5.1 psi) |
| Action Taken: | Abort start of circuit and lock out from running |
| Reset: | This alarm can be cleared manually via the Unit Controller keypad or BAS command if Evap Pressure and Cond Pressure are at least 35 kPa (5.1 psi). |

Low Discharge Superheat

| | |
|-----------------|--|
| Alarm: | Low Discharge Superheat |
| Displayed Text: | Cn Disc SH Low |
| Trigger: | If all of the following are true for at least 30 minutes, the alarm is triggered: <ul style="list-style-type: none"> • Circuit state is Start or Run • Liquid injection is off • DSH < Low DSH Limit set point |
| Action Taken: | Normal shutdown of circuit |
| Reset: | This alarm can be cleared manually via the Unit Controller keypad or via BAS command. |

Compressor VFD Current Output High

| | |
|-----------------|--|
| Alarm: | High Compressor VFD Output Current |
| Displayed Text: | Cn CmpVFD Curr Out Hi |
| Trigger 1: | VFD Output Current > Max Motor Current x 1.05 for at least 30 seconds |
| Trigger 2: | [VFD Output Current > Max Motor Current x 0.99 AND Compressor Speed < 20 Hz] for at least 180 seconds . See the section covering circuit level calculations for the details on the Max Motor Current value. |
| Action Taken: | Rapid shutdown of circuit and lock out from running |
| Reset: | This alarm can be cleared manually via the Unit Controller keypad or via BAS command. |

Compressor VFD Current Input High

| | |
|-----------------|--|
| Alarm: | High Compressor VFD Input Current |
| Displayed Text: | Cn CmpVFD Curr In Hi |
| Trigger: | Alarm will trigger when all of the following are true for at least 5 seconds: <ul style="list-style-type: none"> • Unit mode is Ice • Compressor is running • VFD Input Current > Compressor RLA set point x 105% Compressor RLA set point for each circuit is part of the unit configuration. |
| Action Taken: | Rapid shutdown of circuit and lock out from running |
| Reset: | This alarm can be cleared manually via the Unit Controller keypad or via BAS command. |

Compressor VFD Temperature High

| | |
|-----------------|--|
| Alarm: | Compressor VFD Temperature High |
| Displayed Text: | Cn CompVfdTempHigh |
| Trigger: | VFD Heatsink temperature > Max VFD Temperature for 5 seconds |
| Action Taken: | Rapid shutdown of circuit and lock out from running |
| Reset: | This alarm can be cleared manually via the Unit Controller keypad or via BAS command if temperature ≤ Max VFD Temperature. |

Compressor VFD Temperature Low

| | |
|-----------------|--|
| Alarm: | Compressor VFD Temperature Low |
| Displayed Text: | Cn CompVfdTempLow |
| Trigger: | This alarm is triggered if the Compressor Type is set as 3120 or 3122 and Compressor VFD Temp ≤ -10°C for at least 5 seconds |
| Action Taken: | Rapid shutdown of circuit and lock out from running |
| Reset: | This alarm can be cleared manually via the Unit Controller keypad or via BAS command if Compressor VFD temperature > -5°C. |

Compressor VFD Comm Failure

| | |
|-----------------|---|
| Alarm: | Compressor VFD Comm Failure |
| Displayed Text: | Cn CompVfdCommFail |
| Trigger: | Unit has compressor VFD's and there is either a modbus configuration error or there are 10 consecutive modbus commands that failed to receive a valid response. |
| Action Taken: | Normal shutdown of circuit and lock out from running |
| Reset: | This alarm can be cleared manually via the Unit Controller keypad or via BAS command if communication has been restored. |

Compressor VFD Fault

| | |
|-----------------|--|
| Alarm: | Compressor VFD Fault |
| Displayed Text: | Cn Comp Vfd Fault |
| Trigger: | F3/F4 compressor types: Fault flag from VFD is set and fault code is not 0020H. Other alarms trigger in response to specific fault codes so if the fault is due to those codes, this alarm should not trigger. |
| Action Taken: | Rapid shutdown of circuit and lock out from running |
| Reset: | This alarm can be cleared manually via the Unit Controller keypad or via BAS command. When alarm is cleared, command to reset fault should be sent to VFD. |

CC Module Comm Failure

| | |
|-----------------|---|
| Alarm: | CC Module Comm Failure |
| Displayed Text: | CCn Module Comm Fail |
| Trigger: | Communication with the module has failed. Specifically, this means the reliability value reported for the module is anything other than 0 for at least 3 seconds. |
| Action Taken: | Rapid shutdown of circuit and lock out from running |
| Reset: | This alarm can be cleared manually via the keypad or BAS command after reliability value reported for the module is 0 for at least 5 seconds. |

EEXV Module Comm Failure

| | |
|-----------------|--|
| Alarm: | EEXV Module Comm Failure |
| Displayed Text: | EEXVn Mod Comm Fail |
| Trigger: | Evaporator Expansion Valve Type is set as an ETS model number (see Table 35) and communication with the module has failed. Specifically, this means the reliability value reported for the module is anything other than 0 for at least 3 seconds. |
| Action Taken: | Rapid shutdown of circuit and lock out from running |
| Reset: | This alarm can be cleared manually via the keypad or BAS command after reliability value reported for the module is 0 for at least 5 seconds. |

Evaporator Pressure Sensor Fault

| | |
|-----------------|--|
| Alarm: | Evaporator Pressure Sensor Fault |
| Displayed Text: | Cn EvapPressSenFault |
| Trigger: | Trigger any time sensor input voltage is less than 400 mv and UC communication with CC module is OK for at least 1 second. Trigger when sensor input voltage is more than 4600 mv and UC communication with CC module is OK for at least 1 second. However, this trigger should only occur after circuit state is Start or Run for at least 90 seconds. Trigger if the evaporator approach is less than 1.11°C for more than 30 seconds. This trigger should only be enabled after the circuit state is start or run for 30 seconds. The purpose of this trigger condition is to prevent operation if the sensor is reading high but not out of range. |
| Action Taken: | Rapid shutdown of circuit and lock out from running |
| Reset: | This alarm can be cleared manually via the keypad or BAS command if sensor input voltage is 400 mv to 4600 mv for at least 5 seconds. |

Condenser Pressure Sensor Fault

| | |
|-----------------|---|
| Alarm: | Condenser Pressure Sensor Fault |
| Displayed Text: | Cn CondPressSenFault |
| Trigger: | Trigger any time sensor input voltage is less than 400 mv or more than 4600 mv and UC communication with CC module is OK for at least 1 second. |
| Action Taken: | Rapid shutdown of circuit and lock out from running |
| Reset: | This alarm can be cleared manually via the keypad or BAS command if sensor input voltage is 400 mv to 4600 mv for at least 5 seconds. |

Oil Pressure Sensor Fault

| | |
|-----------------|---|
| Alarm: | Oil Pressure Sensor Fault |
| Displayed Text: | Cn OilPressSenFault |
| Trigger: | Trigger any time sensor input voltage is less than 400 mv or more than 4600 mv and UC communication with CC module is OK for at least 1 second. |
| Action Taken: | Normal shutdown of circuit and lock out from running |
| Reset: | This alarm can be cleared manually via the keypad or BAS command if sensor input voltage is 400 mv to 4600 mv for at least 5 seconds. |

Suction Temperature Sensor Fault

| | |
|-----------------|---|
| Alarm: | Suction Temperature Sensor Fault |
| Displayed Text: | Cn SuctTempSenFault |
| Trigger: | Trigger if any of the following are true for at least 1 second: <ul style="list-style-type: none"> • Sensor input value < 340 Ω • Sensor input value > 300 kΩ • Sensor reliability reported by control system ≠ 'No Fault' |
| Action Taken: | Normal shutdown of circuit and lock out from running |
| Reset: | This alarm can be cleared manually via the keypad or BAS command if sensor input value is 340 Ω to 300 kΩ and sensor reliability = 'No Fault' for at least 5 seconds. |

Discharge Temperature Sensor Fault

| | |
|-----------------|---|
| Alarm: | Discharge Temperature Sensor Fault |
| Displayed Text: | Cn DiscTempSenFault |
| Trigger: | Trigger if any of the following are true for at least 1 second: <ul style="list-style-type: none"> • Sensor input value < 340 Ω • Sensor input value > 300 kΩ • Sensor reliability reported by control system ≠ 'No Fault' |
| Action Taken: | Normal shutdown of circuit and lock out from running |
| Reset: | This alarm can be cleared manually via the keypad or BAS command if sensor input value is 340 Ω to 300 kΩ and sensor reliability = 'No Fault' for at least 5 seconds. |

Evaporator EXV Motor Error

| | |
|-----------------|--|
| Alarm: | Evaporator EXV Motor Error |
| Displayed Text: | Cn EvapExvMotorErr |
| Trigger: | If EEXV Type is set to E6V and driver in Evaporator EXV module reports EXV motor error. Driver A is for circuit #1 and Driver B is for circuit #2. |
| Action Taken: | Rapid shutdown of circuit and lock out from running |
| Reset: | This alarm can be cleared manually via the keypad or BAS command if EXV motor error is no longer being reported. |

Power Loss While Running

| | |
|-----------------|---|
| Alarm: | Power Loss While Running |
| Displayed Text: | Cn PwrLossWhileRun |
| Trigger: | Circuit running when controller loses power |
| Action Taken: | None |
| Reset: | N/A |

Failed Pumpdown

| | |
|-----------------|---|
| Alarm: | Failed Pumpdown |
| Displayed Text: | Cn Pumpdown Fail |
| Trigger: | Circuit state = pumpdown for time > Pumpdown Time set point |
| Action Taken: | Shut down circuit |
| Reset: | N/A |

Economizer Pressure Sensor Fault

| | |
|-----------------|--|
| Alarm: | Economizer Pressure Sensor Fault |
| Displayed Text: | Cn EconPressSenFault |
| Trigger: | The following conditions must be true to trigger: <ul style="list-style-type: none"> • Economizer Configuration set point = Yes • 8 seconds have passed since UC booted up • Communication with EVD module is OK • Value reported is more than 3083 kPa or less than 3.85 kPa for at least 1 second. |
| Action Taken: | Economizer forced to closed state and will remain closed. |
| Reset: | This alarm will automatically clear if value reported is from 3.85 to 3083 kPa for 5 seconds. |

Economizer Temperature Sensor Fault

| | |
|-----------------|---|
| Alarm: | Economizer Temperature Sensor Fault |
| Displayed Text: | Cn EconTempSenFault |
| Trigger: | The following conditions must be true to trigger: <ul style="list-style-type: none"> • Economizer Configuration set point = Yes • Communication with EVD module is OK • Value reported is more than 150°C or less than -40°C for at least 1 second |
| Action Taken: | Economizer forced to closed state and will remain closed. |
| Reset: | This alarm will automatically clear if value reported is from -40°C to 150°C for 5 seconds. |

Economizer EXV Motor Error

| | |
|-----------------|---|
| Alarm: | Economizer EXV Motor Error |
| Displayed Text: | Cn EconExvMotorErr |
| Trigger: | Driver in Economizer EXV module reports EXV motor error. Driver A is for circuit #1 and Driver B is for circuit #2. |
| Action Taken: | Economizer forced to closed state and will remain closed. |
| Reset: | Automatically clear when EXV motor error is not being reported for 5 seconds. |

DC Fan Motor Fault

| | |
|-----------------|--|
| Alarm: | DC Fan Motor Fault |
| Displayed Text: | Cn DcFanMotorFault |
| Trigger: | Any DC fan motor on the circuit has a fault as indicated by a flag sent from the DC controller. |
| Action Taken: | None |
| Reset: | Fault flag is not set for at least one second. This alarm can be cleared manually via the keypad or BAS command if trigger condition is not true. When the alarm clear command is set via keypad or BAS, a request to clear alarms is sent to the DC controller. |

Events

Situations may arise that require some action from the chiller or that should be logged for future reference, but aren't severe enough to track as alarms. These events are stored in a log separate from alarms but accessed through the alarm menu. This log shows the time and date of the latest occurrence, the count of occurrences for the current day, and the count of occurrences for each of the previous seven days.

Unit Power Restore

| | |
|---------------|--------------------------------|
| Trigger: | Unit controller is powered up. |
| Action Taken: | None |
| Reset: | N/A |

Low Evaporator Pressure - Hold

| | |
|---------------|--|
| Trigger: | This event will trigger when the unit mode is Cool, the circuit state is Run, and evaporator pressure drops below the low evaporator pressure hold value for 5 seconds. Low evaporator pressure hold value = Low Evaporator Pressure Unload set point + Low Evaporator Pressure Hold Offset set point |
| Action Taken: | Circuit will not be able to increase in capacity. |
| Reset: | This event is reset when the evaporator pressure rises at least 14 kPa (2.03 psi) above the low evaporator pressure hold value for 3 seconds. It is also reset if the circuit is no longer in the Run state or the unit operating mode is changed to Ice. |

Low Evaporator Pressure - Unload

| | |
|---------------|--|
| Trigger: | This event will trigger when the unit mode is Cool, the circuit state is Run, and evaporator pressure drops below the Low Evaporator Pressure Unload set point for 5 seconds. |
| Action Taken: | Compressor speed will decrease by 1 Hz every second. |
| Reset: | This event is reset when the evaporator pressure rises above the Low Evap Pressure Unload set point for 5 seconds. It is also reset if the circuit is no longer in the Run state or the unit operating mode is changed to Ice. |

High Condenser Pressure - Hold

| | |
|---------------|---|
| Trigger: | This event will trigger when the unit mode = Cool, compressor is running, and saturated condenser temperature > high saturated condenser hold value for at least 5 seconds. |
| Action Taken: | Compressor will not be able to increase |
| Reset: | This event is cleared when the saturated condenser temperature drops at least 2°C below the high saturated condenser hold value for at least 3 minutes. It is also cleared if the circuit is no longer in the Run state or the unit operating mode is changed to Ice. |

High Condenser Pressure - Unload

| | |
|---------------|---|
| Trigger: | This event will trigger when the unit mode = Cool, compressor is running, and saturated condenser temperature > high saturated condenser unload value for at least one second. |
| Action Taken: | The compressor speed will decrease 1 Hz every second. |
| Reset: | This event is cleared when saturated condenser temperature < high saturated condenser unload value for at least 5 seconds. It is also cleared if the compressor is no longer in the Run state or the unit operating mode is changed to Ice. |

Low Pressure Difference Or Ratio Shutdown

| | |
|---------------|---|
| Trigger: | This event will trigger on the first and second occurrence of the below conditions within 2 hours. A third occurrence within a 2 hour window triggers the alarm. Trigger 1: Pressure ratio is less than 1.6 for longer than the Low Pressure Diff/Ratio Delay set point after circuit state transition to Run. Pressure ratio is calculated as shown with pressures in kPa: $Ratio = (Condenser\ Pressure + 101.325) / (Evaporator\ Pressure + 101.325)$ Trigger 2: Pressure difference is less than 180 kPa for longer than the Low Pressure Diff/Ratio Delay set point after circuit state transition to Run. Pressure difference is calculated as shown with pressures in kPa: $Difference = (Condenser\ Pressure) - (Evaporator\ Pressure)$ Alarm/event cannot trigger for 5 minutes after circuit state transitions to Preopen if OAT < 7°C, however the trigger logic will still run during this window. |
| Action Taken: | Rapid shutdown of circuit |
| Reset: | This event resets immediately after triggering. |

High VFD Output Current – Hold

| | |
|---------------|--|
| Trigger: | This event will trigger when all of the following are true for at least for 10 seconds. <ul style="list-style-type: none"> • Unit mode is Cool • Compressor is running • VFD Output Current > Max Motor Current x 0.97 |
| Action Taken: | Compressor will not be able to increase in capacity/speed. |
| Reset: | This event is set when VFD Output Current < Max Motor Current x 0.94 for at least 60 seconds. It is also reset if the compressor is not running or the unit operating mode is changed to Ice. |

High VFD Output Current - Unload

| | |
|---------------|---|
| Trigger: | This event will trigger when all of the following are true for at least 3 seconds. <ul style="list-style-type: none"> • Unit mode is Cool • Compressor is running • VFD Output Current > Max Motor Current x 0.99 |
| Action Taken: | Compressor speed will be reduced at a rate equivalent to 1 Hz every 2 seconds. |
| Reset: | This event is cleared when VFD Output Current < Max Motor Current x 0.99. It is also reset if the compressor is not running or the unit operating mode is changed to Ice. |

High VFD Temperature Hold

| | |
|---------------|--|
| Trigger: | This event will trigger when all of the following are true for at least for 30 seconds. <ul style="list-style-type: none"> • Unit mode is Cool • Compressor is running • VFD Heatsink Temp > Max VFD Temperature - 6°C |
| Action Taken: | Compressor will not be able to increase speed/capacity. |
| Reset: | This event is reset when VFD Heatsink Temp < Max VFD Temperature - 6°C for at least 60 seconds. It is also reset when the compressor is not running or the unit operating mode is changed to Ice. |

High VFD Line Current Hold

| | |
|---------------|---|
| Trigger: | This event will trigger when all of the following are true for at least for 5 seconds. <ul style="list-style-type: none"> • Unit mode is Cool • Compressor is running • VFD Line Current > Compressor RLA set point <p>Compressor RLA set point for each circuit is part of the unit configuration.</p> |
| Action Taken: | Compressor will not be able to increase speed/capacity. |
| Reset: | This event is reset when VFD Line Current < Compressor RLA set point x 0.99 for at least 3 minutes. It is also reset when the compressor is not running or the unit operating mode is changed to Ice. |

High VFD Temperature Unload

| | |
|---------------|--|
| Trigger: | This event will trigger when all of the following are true for at least for 30 seconds. <ul style="list-style-type: none"> • Unit mode is Cool • Compressor is running • VFD Heatsink Temp > Max VFD Temperature - 3°C |
| Action Taken: | Compressor speed reduced by 1 Hz every 10 seconds. |
| Reset: | This event is reset when VFD Heatsink Temp ≤ Max VFD Temperature - 3°C. It is also reset when the compressor is not running or the unit operating mode is changed to Ice. |

High VFD Line Current Unload

| | |
|---------------|--|
| Trigger: | This event will trigger when all of the following are true for at least for 5 seconds. <ul style="list-style-type: none"> • Unit mode is Cool • Compressor is running • VFD Line Current > Compressor RLA set point x 105% <p>Compressor RLA set point for each circuit is part of the unit configuration.</p> |
| Action Taken: | Compressor speed reduced 1 Hz every 2 seconds. |
| Reset: | This event is reset when VFD Line Current ≤ Compressor RLA set point x 105%. It is also reset when the compressor is not running or the unit operating mode is changed to Ice. |

Compressor Start Failure

| | |
|---------------|--|
| Trigger: | This event will trigger on the first and second occurrence of the below conditions within 2 hours. A third occurrence within a 2 hour window triggers the alarm. All of the following must be true to trigger: <ul style="list-style-type: none"> • Compressor Run command is on • Compressor VFD Communication Failure is not active • Either VFD Actual Speed = 0 for more than 15 seconds <u>or</u> VFD Actual Speed < 13 Hz for more than 30 seconds. |
| Action Taken: | Rapid shutdown of circuit |
| Reset: | N/A |

Unit Controller Operation

Figure 86: Unit Controller

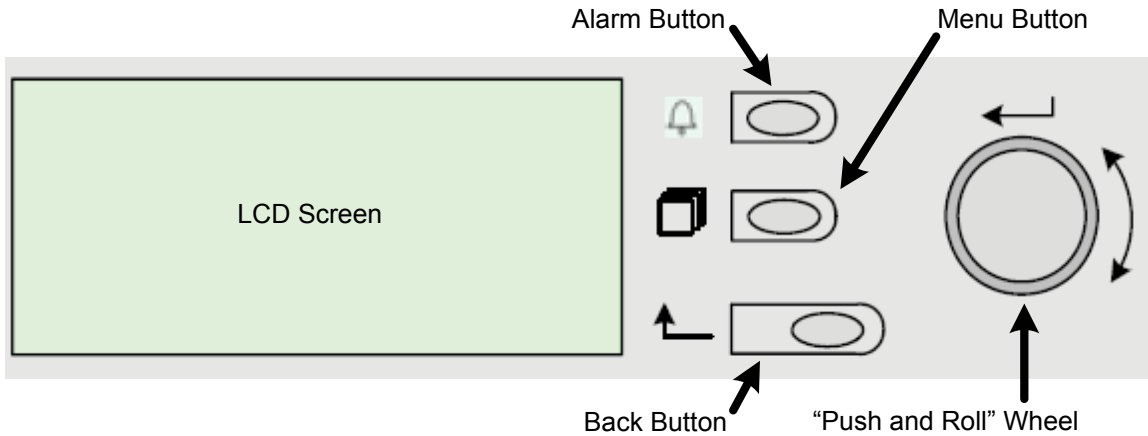

The keypad/display consists of a 5-line by 22-character display, three buttons (keys) and a “push and roll” navigation wheel. There is an Alarm Button, Menu (Home) Button, and a Back Button. The wheel is used to navigate between lines on a screen (page) and to increase and decrease changeable values when editing. Pushing the wheel acts as an Enter Button and will jump from a link to the next set of parameters.

Figure 87: Typical Screen

| | | |
|-----|--------------------|---|
| ▲ ▼ | View/Set Unit | 3 |
| | Status/Settings | > |
| | Set Up | > |
| | Temperatures | > |
| | Date/Time/Schedule | > |

Three types of lines exist:

- Menu title, displayed in the first line as in Figure 87.
- Link (also called Jump) having an arrow (>) in the right of the line and used to link to the next menu.
- Parameters with a value or adjustable set point.

The first line visible on each display includes the menu title and the line number to which the cursor is currently “pointing”, in the above menu representation, “Temperatures” is highlighted.

The leftmost position of the title line includes an “up” arrow ▲ to indicate there are lines (parameters) “above” the currently displayed line; and/or a “down” arrow ▼ to indicate there are lines (parameters) “below” the currently displayed items or an “up/down” arrow to indicate there are lines “above and below” the currently displayed line.

Each line on a screen can contain status-only information or include changeable data fields (set points).

A line in a menu may also be a link to further menus. This is often referred to as a jump line, meaning pushing the navigation wheel will cause a “jump” to a new menu. An arrow

is displayed to the far right of the line to indicate it is a “jump” line and the entire line is highlighted when the cursor is on that line.

Navigating

When power is applied to the control circuit, the controller screen will be active and display the Home screen, which can also be accessed by pressing the Menu button. The navigating wheel is the only navigating device necessary, although the Menu, Alarm, and Back buttons can provide shortcuts as explained later.

Passwords

There are four levels of access for the user interface:

- No password
- Operator level - 5321
- Technician/Manager level - will be provided at startup
- Daikin Applied service technician level

Enter passwords from the Main Menu:

- Enter Password links to the Entry screen, which is an editable screen. Pressing the wheel goes to the edit mode where the password can be entered. The first (*) will be highlighted; rotate the wheel clockwise to the first number and set it by pressing the wheel. Repeat for the remaining three numbers. The password will time out after 10 minutes with no keypad activity, and is cancelled if a new password is entered or the control powers down.
- Not entering a password allows access to a limited number of parameters.

Information presented at the controller is relative to the password access level; the most extensive menus are available to service technicians.

Entering an invalid password has the same effect as not entering a password.

Once a valid password has been entered, the controller allows further changes and access without requiring the user to enter a password until either the password timer expires or a different password is entered. The default value for this password timer is 10 minutes.

Navigation Mode

When the navigation wheel is turned clockwise, the cursor moves to the next line (down) on the page. When the wheel is turned counterclockwise the cursor moves to the previous line (up) on the page. The faster the wheel is turned the faster the cursor moves. Pushing the wheel acts as an “Enter” button.

When the Back button is pressed, the display reverts back to the previously displayed page. If the Back button is repeatedly pressed, the display continues to revert one page back along the current navigation path until the “main menu” is reached.

When the Menu (Home) button is pressed the display reverts to the “main page.”

When the Alarm button is depressed, the Alarm Lists menu is displayed.

Edit Mode

The Edit Mode is entered by pressing the navigation wheel while the cursor is pointing to a line containing an editable field. Once in the Edit Mode, pressing the wheel again causes the editable field to be highlighted. Turning the wheel clockwise while the editable field is highlighted causes the value to be increased. Turning the wheel counterclockwise while the editable field is highlighted causes the value to be decreased. The faster the wheel is turned the faster the value is increased or decreased. Pressing the wheel again will cause the new value to be saved and the keypad/display to leave the Edit Mode and return to Navigation Mode.

Figure 88: Example of Screen Menu

| |
|-------------------------|
| Main Menu |
| Enter Password |
| Quick Menu |
| View/Set Unit |
| View/Set Circuit |
| Unit Status |
| Active Setpoint |

NOTE: Installation and maintenance are to be performed only by qualified personnel who are familiar with local codes and regulations, and experienced with this type of equipment.

⚠ DANGER

LOCKOUT/TAGOUT all forms of hazardous energy and power sources prior to starting, pressurizing, de-pressuring, or powering down the chiller. Failure to follow this warning exactly can result in serious injury or death. Be sure to read and understand the installation, operation, and service instructions within this manual.

Pre-startup

Inspect the chiller to ensure no components became loose or damaged during shipping or installation, including leak test and wiring check. Complete the pre-start checklist at the front of this manual and return to Daikin Applied prior to startup date.

NOTICE

Daikin Applied service personnel or factory authorized service agency must perform initial startup in order to activate warranty. Return the “Screw Compressor Equipment Warranty Form” within 10 working days to Daikin Applied as instructed on the form to obtain full warranty benefits.

⚠ CAUTION

Most relays and terminals in the unit control center are powered when S1 is closed and the control circuit disconnect is on. Therefore, do not close S1 until ready for startup or the unit may start unintentionally and possibly cause equipment damage.

Startup

1. Verify requirements from “Chilled Water Piping” on page 17 are met. including flushing the system water piping **before** connecting to the unit.
2. Verify chilled water flow rate and calibrate thermal dispersion flow switch - see instructions on page 90.
3. Double check that the discharge shutoff valve and the optional compressor suction butterfly valves are open.
4. Check that the manual liquid line shutoff valves at the outlet of the subcooler coils are open.
5. Check the leaving chilled water temperature set point on the MicroTech® III controller to be sure it is set at the desired chilled water temperature.
6. Start the auxiliary equipment for the installation by turning on the time clock, and/or remote on/off switch, and chilled water pump.
7. Check to see that pumpdown switches Q1 and Q2 are in the “Pumpdown and Stop” (open) position. Throw the S1 switch to the “Auto” position.
8. Repeat step 7 for Q2

9. Under the “Control Mode” menu of the keypad, place the unit into the automatic Cool Mode.
10. Start the system by moving pumpdown switch Q1 to the “Auto” position.

Temporary Shutdown

Move pumpdown switches Q1 and Q2 to the “Pumpdown and Stop” position. After the compressors have pumped down, turn off the chilled water pump.

⚠ CAUTION

Do not turn the unit off using the “Override Stop” switch, without first moving Q1 and Q2 to the “Stop” position, unless it is an emergency, as this will prevent the unit from going through a proper shutdown/pumpdown sequence, resulting in possible equipment damage.

⚠ CAUTION

The unit has a onetime pumpdown operation. When Q1 and Q2 are in the “Pumpdown and Stop” position, the unit will pump down once and not run again until the Q1 and Q2 switches are moved to the “Auto” position. If Q1 and Q2 are in the “Auto” position and the load has been satisfied, the unit will go into onetime pumpdown and will remain off until the MicroTech® III control senses a call for cooling and starts the unit.

⚠ CAUTION

Water flow to the unit must not be interrupted before the compressors pump down to avoid freeze-up in the evaporator. Interruption will cause equipment damage.

⚠ CAUTION

If all power to the unit is turned off, the compressor heaters will become inoperable. Once power is resumed to the unit, the compressor and oil separator heaters must be energized a minimum of 12 hours before attempting to start the unit. Failure to do so can damage the compressors due to excessive accumulation of liquid in the compressor.

Startup After Temporary Shutdown

1. Insure that the compressor and oil separator heaters have been energized for at least 12 hours prior to starting the unit.
2. Start the chilled water pump.
3. With system switch Q0 in the “On” position, move pumpdown switches Q1 and Q2 to the “Auto” position.
4. Observe the unit operation until the system has stabilized.

Extended (Seasonal) Shutdown

1. Move the Q1 and Q2 switches to the Manual Pumpdown position.
2. After the compressors have pumped down, turn off the chilled water pump.
3. Turn off all power to the unit and to the chilled water pump.
4. If fluid is left in the evaporator, confirm that the evaporator heaters are operational.
5. Move the emergency stop switch S1 to the "Off" position.
6. Close the compressor discharge valve and the optional compressor suction valve (if so equipped) as well as the liquid line shutoff valves.
7. Tag all opened compressor disconnect switches to warn against startup before opening the compressor suction valve and liquid line shutoff valves.
8. If glycol is not used in the system, drain all water from the unit evaporator and chilled water piping if the unit is to be shutdown during winter and temperatures below -20°F can be expected. The evaporator is equipped with heaters to help protect it down to -20°F. Chilled water piping must be protected with field-installed protection. Do not leave the vessels or piping open to the atmosphere over the shutdown period.
9. Do not apply power to the evaporator heaters if the system is drained of fluids as this can cause the heaters to burn out.

- from the system piping. Open all water flow valves and start the chilled water pump. Check all piping for leaks and recheck for air in the system. Verify the correct flow rate by taking the pressure drop across the evaporator and compare to the graphs beginning on [page 45](#).
8. Set the chilled water set point to the required temperature. The system water temperature must be greater than the total of the leaving water temperature set point plus one-half the control band plus the startup Delta-T before the MicroTech® III controller will stage on cooling.
 9. Under the "Control Mode" menu of the keypad, place the unit into the automatic Cool Mode.
 10. Start the system by moving pumpdown switches to the "Auto" position.

Startup After Extended (Seasonal) Shutdown

1. With all electrical disconnects locked and tagged out, check all screw or lug-type electrical connections to be sure they are tight for good electrical contact.
2. Check the voltage of the unit power supply and see that it is within the $\pm 10\%$ tolerance that is allowed. Voltage unbalance between phases must be within $\pm 2\%$.
3. See that all auxiliary control equipment is operative and that an adequate cooling load is available for startup.
4. Check all compressor flange connections for tightness to avoid refrigerant loss. Always replace valve seal caps.
5. Make sure system switch Q0 is in the "Stop" position and pumpdown switches Q1 and Q2 are set to "Pumpdown and Stop". Throw the main power and control disconnect switches to "On." This will energize the crankcase heaters. Wait a minimum of 12 hours before starting up unit. Turn compressor circuit breakers to "Off" position until ready to start unit.
6. Open the optional compressor suction butterfly valves, the liquid line shutoff valves, and compressor discharge valves.
7. Vent the air from the evaporator water side as well as

Flow Switch Installation and Calibration

A thermal dispersion flow switch uses heat to determine flow and therefore must be calibrated during system startup. A thermal dispersion flow switch can be an acceptable replacement for paddle type flow switches and differential pressure switches but care must be taken regarding wiring.

The thermal dispersion flow switch supplied by Daikin Applied, shown in Figure 1, comes as a 2 part unit consisting of a flow switch and an adapter labeled E40242 by the supplier.

Figure 90: Thermal Dispersion Flow Switch and Adapter



IMPORTANT: Flow switch MUST be calibrated before chiller operation. Failure to properly calibrate the switch may result in severe chiller damage and/or void warranty.



Mounting

Figure 91 highlights the position of the electrical connector and indentation 'mark' on flow switch.

Figure 91: Flow Switch Details

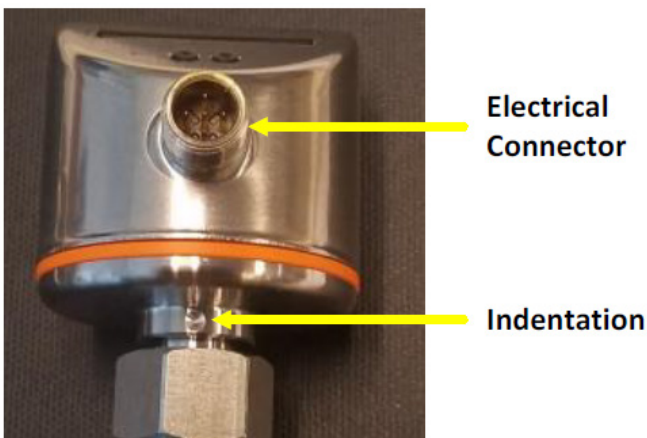

It is recommended, if possible, that the flow switch be mounted such that the electrical connection and indentation 'mark' are pointed in the direction of flow as shown in Figure 92. It is important that the flow switch be mounted so that the probe is sufficiently inserted into the fluid stream. It may not be mounted directly on top or directly on the bottom of a horizontal pipe.

If the flow sensor is to be mounted away from the unit, the sensor should be mounted on the wall of the outlet pipe to the evaporator, or in a run of straight pipe that allows 5 to 10 pipe diameters prior to the sensor and 3 to 5 pipe diameters of straight pipe after the sensor. Flow switch is placed in outlet pipe to reflect flow leaving the barrel. If installation on the inlet pipe is necessary, contact Chiller Technical Response at TechResponse@DaikinApplied.com to review the jobsite details.

NOTE: DO NOT alter or relocate factory installed flow switch. If issues exist, contact Chiller Technical Response at TechResponse@DaikinApplied.com.

Figure 92: Remote Mounting Guidelines for Flow Switch

| General | | |
|-------------|--|--|
| Recommended | | |
| To avoid | | |

If needed, the adapter is threaded into the pipe using pipe sealant appropriate for the application. The flow sensor is mounted onto the adapter using silicone grease. Carefully apply lubricant to the inside threads and o-ring so temperature probe does not become coated with lubricant. Torque the adapter/sensor connection to 18.5 ft/lbs.

Wiring

Refer to wiring diagram in the unit control panel.

Either AC or DC is used to power the flow switch. The unit controller's digital input is a DC signal which is supplied through the switch output of the flow switch for flow indication. It is required that the AC and DC commons of power be separated. Contact Chiller Technical Response for alternate wiring scenarios.

Flow Switch Setup

The flow switch comes from the factory set at a default velocity of 20 cm/s. This value is typically well below the minimum water flow specified for the unit's evaporator so field adjustment is required for adequate low flow protection. Table 54 are the calculated gallons per minute (gpm) for Schedule 40 steel pipe for various fluid velocities from 20 cm/s to 300 cm/s. The flow switch has an overall range of adjustment from 3 cm/s to 300 cm/s.

Table 54: Flow Volume Calculation

| Pipe Size (inch) | Inside Pipe Diameter (inch) | US GPM at the velocities indicated below | | | | | | | | | GPM adjustment per '+' or '-' key input |
|------------------|-----------------------------|--|-----------|-----------|-----------|-----------|------------|------------|------------|------------|---|
| | | Default | 20 cm/sec | 30 cm/sec | 50 cm/sec | 75 cm/sec | 100 cm/sec | 150 cm/sec | 200 cm/sec | 250 cm/sec | |
| 2 | 2.06 | 6.86 | 10.3 | 17.2 | 25.7 | 34.3 | 51.5 | 68.6 | 85.8 | 102.9 | 1.72 |
| 2.5 | 2.46 | 9.79 | 14.7 | 24.5 | 36.7 | 49.0 | 73.4 | 97.9 | 122.4 | 146.9 | 2.42 |
| 3 | 3.07 | 15.1 | 22.7 | 37.8 | 56.7 | 75.6 | 113.4 | 151.2 | 189.0 | 226.8 | 3.78 |
| 3.5 | 3.55 | 20.2 | 30.3 | 50.6 | 75.8 | 101.1 | 151.7 | 202.2 | 252.8 | 303.3 | 5.06 |
| 4 | 4.03 | 26.0 | 39.1 | 65.1 | 97.7 | 130.2 | 195.3 | 260.4 | 325.5 | 390.5 | 6.51 |
| 5 | 5.05 | 40.9 | 61.4 | 102.3 | 153.5 | 204.6 | 306.9 | 409.2 | 511.5 | 613.7 | 10.2 |
| 6 | 6.07 | 59.1 | 88.6 | 147.7 | 221.6 | 295.5 | 443.2 | 590.9 | 738.7 | 886.3 | 14.8 |
| 8 | 7.98 | 102.3 | 153.5 | 255.8 | 383.7 | 511.6 | 767.5 | 1023.3 | 1279.1 | 1534.7 | 25.6 |
| 10 | 10.02 | 161.3 | 241.9 | 403.2 | 604.8 | 806.5 | 1209.7 | 1612.9 | 2016.2 | 2419.1 | 39.0 |
| 12 | 11.94 | 229.0 | 343.4 | 572.4 | 858.6 | 1144.7 | 1717.1 | 2289.5 | 2861.9 | 3433.8 | 57.2 |
| 14 | 13.13 | 276.8 | 415.2 | 692.0 | 1037.9 | 1383.9 | 2075.9 | 2767.8 | 3459.8 | 4151.3 | 69.2 |
| 16 | 15.00 | 361.5 | 542.2 | 903.6 | 1355.5 | 1807.3 | 2710.9 | 3614.6 | 4518.2 | 5421.2 | 90.4 |
| 18 | 16.88 | 457.5 | 686.3 | 1143.8 | 1715.7 | 2287.6 | 3431.4 | 4575.2 | 5719.0 | 6862.1 | 114.4 |
| 20 | 18.81 | 572.4 | 853.0 | 1421.6 | 2132.4 | 2843.2 | 4264.8 | 5686.4 | 7108.0 | 8528.6 | 142.2 |

Step 1: Adjust flow through the evaporator to the minimum desired operating gpm. Maintain this flow throughout the setup procedure.

Step 2: Once steady state minimum desired operating flow is obtained, perform the 'Teach' function on the flow switch. The 'Teach' function is initiated by holding down the minus '-' button on the face of the flow switch for 15 seconds. During this 15 second period, LEDs '0' and '9' will be lit green. Once the 'Teach' function is completed, the outer LEDs will flash green as shown in Figure 93.

Figure 93: Automatic Teach of Set point

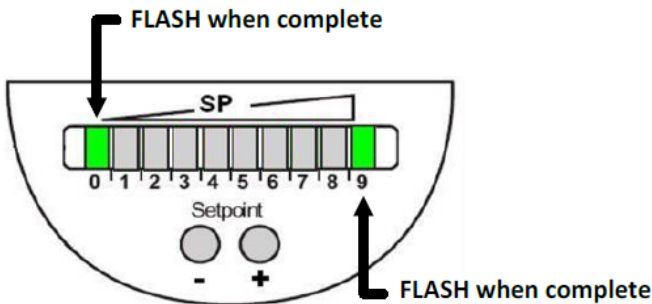

Step 3: After the 'Teach' function is completed and the outer LEDs flashed, the flow switch will indicate a new set point based upon the current flow which should still be at the steady state minimum desired operating flow. Figure 94 shows a typical display for this condition. All LEDs to the left of the SP LED are lit green. The SP LED is lit RED (or may toggle amber) which indicates that the flow switch is OPEN. Typically, an increase in fluid flow is between 15% to 30% above the 'Teach' function flow is required for the SP LED to turn AMBER

and the flow switch to CLOSE indicating acceptable flow.

Figure 94: Teach Adjustment Complete

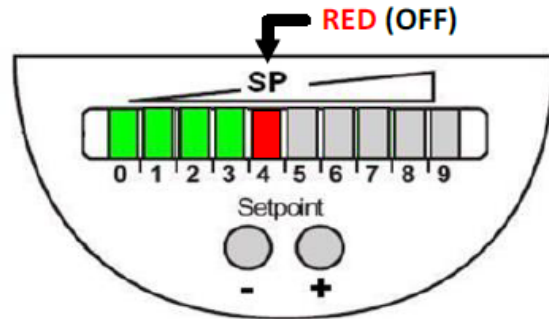

In Step 3, the 'Teach' function re-adjusted the flow switch set point (SP) while flow was at the minimum desired operating flow. The chiller will not operate at this flow because the flow switch is OPEN after performing the 'Teach' function. The benefit of the 'Teach' function is to quickly set the set point within the desired operating range. Additional 'manual' adjustment of set point is required in order to allow for chiller operation at this minimum flow. The '+' and '-' buttons on the face of the flow switch allow for the manual adjustment of the SP. Pressing the '+' button reduces the flow set point while pressing the '-' button increases the flow set point. Each button press, '+' or '-', changes the flow set point by 2.5 cm/s.

Step 4: Press the '+' button until LED '9' begins to flash, as shown in Figure 95. Opening of flow switch should now occur at approximately 80% to 90% of minimum flow.

Figure 95: Upper Range of Minimum Flow

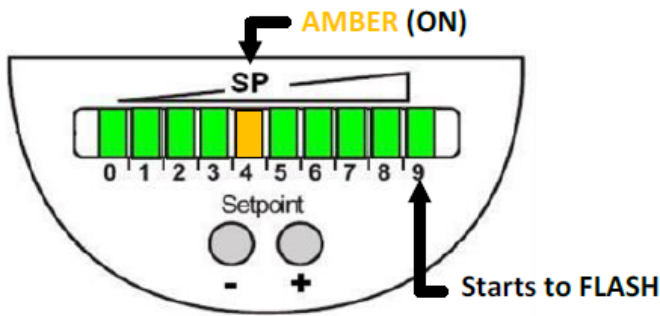

Step 5: Once the SP is set, it is recommended that the sensor be locked to avoid inadvertent readjustment. This can be performed by pressing both the '+' and '-' buttons simultaneously for 10 seconds. The indication goes out momentarily indicating the unit is locked. To unlock, the same procedure is performed to toggle to unlocked.

- NOTE:**
1. The LED window display on flow switch represents a velocity range of 50 cm/s. The window centers on the set point (SP). For example, if the SP was set to 200 cm/s, then the LED labeled '0' would represent a velocity of 180 cm/s when lit and the LED labeled 9 would represent a velocity of 230 cm/s when lit.
 2. Each LED represents 5 cm/s, or two presses of the '+' or '-' buttons.
 3. When power is initially applied to the flow switch, all green LEDs light and go out step by step. During this time, the output is closed. The unit is in the operating mode.
 4. When making manual adjustments to the set point (SP), if no button is pressed for 2 seconds, the unit returns to the operating mode with the newly set value.

Flow below display range: The SP LED will be lit red and the leftmost LED will be flashing green. For example, if the SP was set to 200 cm/s, the flashing labeled '0' would indicate that the flow was below 180 cm/s. This would be shown if no flow through chiller or lowered than desired flow.

Figure 96: Display for Flow Below Range

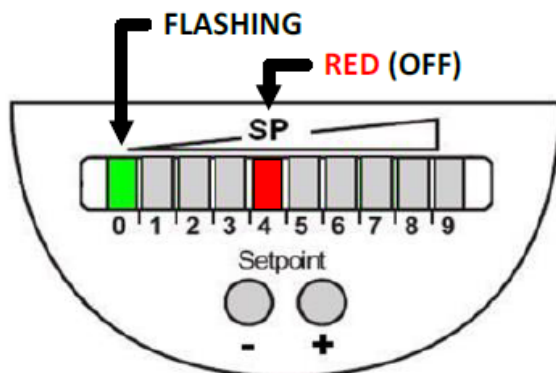

Flow above display range: The SP LED will be lit amber, all LEDs to the left and right of the SP LED will be green with the rightmost LED flashing green. For example, if the SP was set to 200 cm/s, the flashing LED labeled '9' would indicate that the flow was above 230 cm/s. This may be a normal display depending on range by which flow varies through chiller.

Figure 97: Display for Flow Above Range

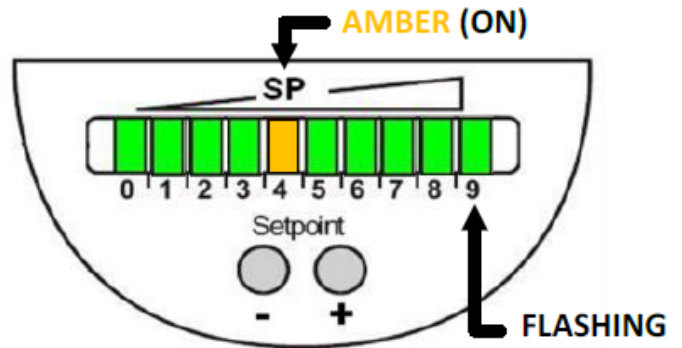

General

On initial startup and periodically during operation, it will be necessary to perform certain routine service checks. Among these are checking the liquid line sight glasses, and the compressor oil level sight glass. In addition, check the MicroTech® III controller temperature and pressure readings with gauges and thermometers to see that the unit has normal condensing/suction pressure and superheat/subcooling readings.

A Periodic Maintenance Log is located at the end of this manual. It is suggested that the log be copied and a report be completed on a regular basis. The log will serve as a useful tool for a service technician in the event service is required.

Initial startup date, vibration readings, and oil analysis information should be kept for reference baseline data.

If the service technician has determined that the refrigerant charge has been contaminated, the charge should be recovered and tested for contaminants or noncondensables. Appropriate actions should be taken based on testing and Clean Air Act regulations.

Vibration Monitoring (Optional)

Vibration readings are often used as an indicator of a possible problem requiring maintenance. If vibration monitoring is part of the site PM program, the compressor can be checked with a vibration analyzer on an annual basis. When doing the annual testing, the load should be maintained as closely as possible to the load of the original test. The initial vibration analysis test provides a benchmark of the compressor, and when performed routinely, can give a warning of impending problems.

Lubrication

The fan motor bearings are permanently lubricated. No further lubrication is required. Excessive fan motor bearing noise is an indication of a potential bearing failure.

POE type oil is used for compressor lubrication. This type of oil is extremely hygroscopic, which means it will quickly absorb moisture if exposed to air and form acids that can be harmful to the chiller. Avoid prolonged exposure of refrigerant to the atmosphere to prevent this problem.

CAUTION

POE oil must be handled carefully using proper protective equipment (gloves, eye protection, etc.). The oil must not come into contact with certain polymers (e.g. PVC) as it may absorb moisture from this material. Also, do not use oil or refrigerant additives to the system.

It is important that only the manufacturer's recommended oil be used. Acceptable POE oil types are:

- CPI/Lubrizol Emkarate RL68H
- Exxon/Mobil EAL Arctic 68
- Hatcol 3693

The compressor oil heater is 250 watts and is on when the compressor is off and off when the compressor is on.

Table 55: Oil Charge per Compressor

| Compressor Designation | Oil Quantity (gallons) |
|------------------------|------------------------|
| 3120, 3122 | 3.43 |
| 3AL, 3BL | 4.7 |
| 4AL | 6.6 |

Oil Filter Removal and Renewal

Prior to this procedure, pump out the compressor. Isolate the electrical supply to the control panels and compressor motor terminal. Filter should be changed when pressure drop delta goes above the linear line in Figure 98.

Figure 98: Pressure Drop to Change Oil Filter

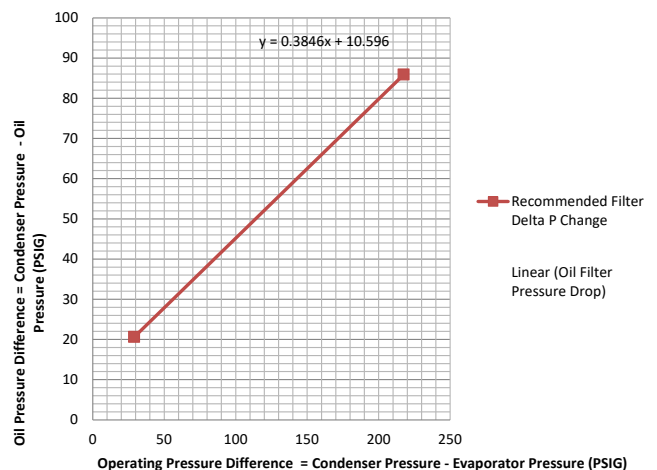

WARNING

After the compressor has been pumped down and isolated, the oil contained inside the filter housing will remain hot enough to cause burns for some time afterwards. Always allow sufficient time for the oil to cool down so that it is cool enough not to be a danger when drained off (less than 35°C is recommended). Severe injury from burns can result.

Figure 99: Oil Filter Location (Including Cutaway View)

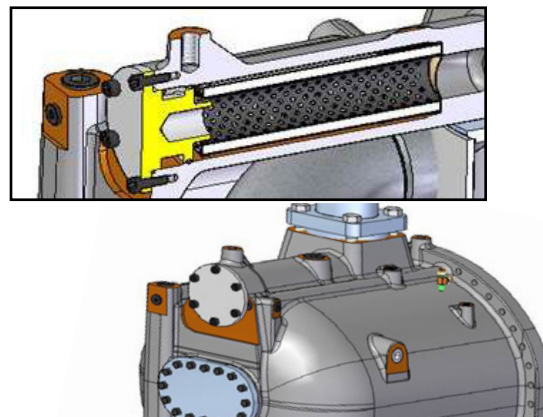
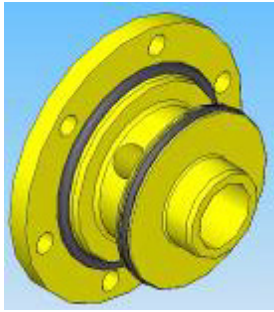

Figure 100: Oil Filter Housing Cover Plate



Oil filter assembly components are:

- Oil Filter – 250 mm
- Oil Filter Housing Cover
- O-Ring – 89.5x3
- O-Ring – 76.1x3.4
- (6) M8 Bolts

Disassembly Procedure

1. Unscrew and remove two hex head side cover bolts 180° apart. Insert M8 guide studs into the vacant holes.
2. Remove remaining bolts and oil filter housing cover.
3. Pull the oil filter off of the spigot and withdraw the oil filter from the housing and clean the housing.



4. Clean oil filter housing cover plate and all other components.

Fitting a New Oil Filter Element – Reassembly

Before reassembly, remove any paint from joint faces. Inspect parts individually for damage and ensure they are completely clean before laying them out on a clean surface in a logical order ready for reassembly.

Use fresh refrigerant oil to lubricate parts during reassembly.

1. Install new O-rings on the oil filter housing cover.
2. Insert new oil filter into the housing, ensuring the filter sits tightly on the sealing spigot.
3. Replace the oil filter housing cover.

4. Evacuate air and noncondensables before valving refrigerant back into the compressor.

Electrical Terminals

⚠ DANGER

Electric equipment can cause electric shock which will cause severe personal injury or death. Turn off, lock out and tag all power before continuing with following service. Panels can have more than one power source.

⚠ CAUTION

Periodically check electrical terminals for tightness and tighten as required. Always use a backup wrench when tightening electrical terminals.

All-Aluminum Condenser Coils

The condenser coils are an all-aluminum design including the connections, microchannel, fins (an oven brazing process brazes the fins to the microchannel flat tube), and headers (see “[Microchannel Coil Cross Section](#)”), which eliminates the possibility of corrosion normally found between dissimilar metals of standard coils.

During the condensing process, refrigerant in the coil passes through the microchannel flat tubes, resulting in higher efficiency heat transfer from the refrigerant to the airstream. In the unlikely occurrence of a coil leak, contact Daikin Applied to receive a replacement coil module.

Figure 101: Microchannel Coil Cross Section

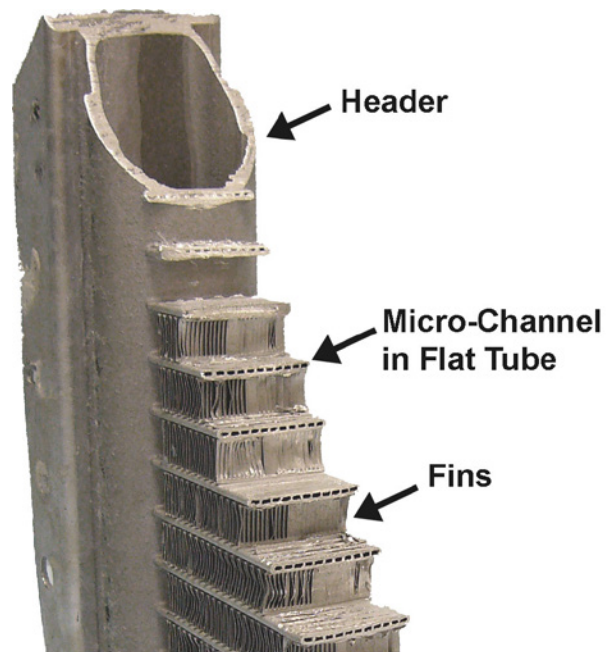

Cleaning Microchannel Aluminum Coils

Maintenance consists primarily of the routine removal of dirt and debris from the outside surface of the fins.

WARNING

Prior to cleaning the unit, turn off and lock out the main power switch to the unit and close all access panels.

Remove Surface Loaded Fibers

Surface loaded fibers or dirt should be removed prior to water rinse to prevent further restriction of airflow. If unable to back wash the side of the coil opposite that of the coils entering air side, then surface loaded fibers or dirt should be removed with a vacuum cleaner. If a vacuum cleaner is not available, a soft non-metallic bristle brush may be used. In either case, the tool should be applied in the direction of the fins.

NOTE: Use of a water stream, such as a garden hose, against a surface loaded coil will drive the fibers and dirt into the coil. This will make cleaning efforts more difficult. Surface loaded fibers must be completely removed prior to using low velocity clean water rinse.

Periodic Clean Water Rinse

A monthly clean water rinse is recommended for coils that are applied in coastal or industrial environments to help to remove chlorides, dirt and debris. An elevated water temperature (not to exceed 130°F) will reduce surface tension, increasing the ability to remove chlorides and dirt. Pressure washer pressure must not exceed 600 psig and the nozzle should remain at least one foot from the coil to avoid damaging fin edges.

High Velocity Water or Compressed Air

High velocity water from a pressure washer or compressed air should only be used at a very low pressure to prevent fin and/or coil damages. The force of the water or air jet may bend the fin edges and increase airside pressure drop. Reduced unit performance or nuisance unit shutdowns may occur.

No maintenance is ordinarily required except the routine removal of dirt and debris from the outside surface of the fins. Daikin recommends the use of non-caustic, non-acidic cleaners available at most air conditioning supply outlets. Flush the coil from the inside out.

Cleaning Epoxy Coated Coils

The following additional cleaning procedures are recommended as part of the routine maintenance activities for epoxy coated coils. Documented routine cleaning of epoxy coated coils is required to maintain warranty coverage.

Routine Quarterly Cleaning of Epoxy Coil

Quarterly cleaning is essential to extend the life of an epoxy coated coil and is required to maintain warranty coverage. Coil cleaning shall be part of the unit's regularly scheduled maintenance procedures. Failure to clean an epoxy coated coil will void the warranty and may result in reduced efficiency and durability in the environment.

For routine quarterly cleaning, first remove surface debris and then clean the coil with an approved coil cleaner (see approved products list in Table 56). After cleaning the coils with the approved cleaning agent, use the approved chloride remover to remove soluble salts and revitalize the unit.

Recommended Coil Cleaner

The following cleaning agents, assuming they are used in accordance with the manufacturer's directions on the container for proper mixing and cleaning, have been approved for use on epoxy coated coils to remove mold, mildew, dust, soot, greasy residue, lint and other particulate:

Table 56: Epoxy Coil Recommended Cleaning Agents

| Cleaning Agent | Reseller | Part Number |
|-------------------------|---|---------------|
| Enviro-Coil Concentrate | Hydro-Balance Corp P.O. Box 730 Prosper, TX 75078 800-527-5166 | H-EC01 |
| Enviro-Coil Concentrate | Home Depot | H-EC01 |
| Chloride Remover | Chlor*Rid Int'l, Inc. P.O. Box 908 Chandler, AZ 85244 800-422-3217 | Chlor*Rid DTS |

CHLOR*RID DTS™ should be used to remove soluble salts from the epoxy coated coil, but the directions must be followed closely. This product is not intended for use as a degreaser. Any grease or oil film should first be removed with the approved cleaning agent.

1. Remove Barrier - Soluble salts adhere themselves to the substrate. For the effective use of this product, the product must be able to come in contact with the salts. These salts may be beneath any soils, grease or dirt; therefore, these barriers must be removed prior to application of this product. As in all surface preparation, the best work yields the best results.
2. Apply CHLOR*RID DTS - Apply CHLOR*RID DTS directly onto the substrate. Sufficient product must be applied uniformly across the substrate to thoroughly wet out surface with no areas missed. This may be accomplished by use of a pump-up sprayer or conventional spray gun. The method does not matter, as long as the entire area to be cleaned is wetted. After the substrate has been thoroughly wetted, the salts will be soluble and is now only necessary to rinse them off.
3. Rinse - It is highly recommended that a hose be used as a pressure washer will damage the fins. The water used for the rinse is recommended to be of potable quality, though a lesser quality of water may be used if a small amount of CHLOR*RID DTS is added. Check with CHLOR*RID International, Inc. for recommendations on lesser quality rinse water.

Harsh Chemical and Acid Cleaners

Harsh chemicals, household bleach or acid cleaners should not be used to clean epoxy coated coils. These cleaners can be very difficult to rinse out of the coil and can accelerate corrosion and attack the epoxy coating. If there is dirt below the surface of the coil, use the recommended coil cleaners as described above.

 **WARNING**

Use caution when applying coil cleaners. They can contain potentially harmful chemicals. Wear breathing apparatus and protective clothing. Carefully follow the cleaner manufacturer's MSDS sheets. Thoroughly rinse all surfaces to remove any cleaner residue. Do not damage the fins.

Liquid Line Sight Glass

Observe the refrigerant sight glasses weekly. A clear glass of liquid indicates that there is adequate refrigerant charge in the system to provide proper feed through the expansion valve.

Bubbling refrigerant in the sight glass, during stable run conditions, may indicate that there can be an EXV problem since the EXV regulates refrigerant flow. Refrigerant gas flashing in the sight glass could also indicate an excessive pressure drop in the liquid line, possibly due to a clogged filter-drier or a restriction elsewhere in the liquid line.

An element inside the sight glass indicates the moisture condition corresponding to a given element color. If the sight glass does not indicate a dry condition after about 12 hours of operation, an oil acid test is recommended.

Do not use the sight glass on the EXV body for refrigerant charging. Its purpose is to view the position of the valve.

Lead-Lag

A feature on all Daikin Pathfinder® air-cooled chillers is a system for alternating the sequence in which the compressors start to balance the number of starts and run hours. Lead-Lag of the refrigerant circuits is accomplished automatically

through the MicroTech® III controller. When in the auto mode, the circuit with the fewest number of starts will be started first. If all circuits are operating and a stage down in the number of operating compressors is required, the circuit with the most operating hours will cycle off first. The operator can override the MicroTech® III controller, and manually select the lead circuit as circuit #1 or #2.

Pump Operation

It is highly recommended that the chiller unit control the chilled water pump(s). The integral chiller control system has the capability to selectively start pump A or B or automatically alternate pump selection at each start and also has pump standby operation capability.

Failure to have the chiller control the pumps may cause the following problems:

1. If any device, other than the chiller, should try to start the chiller without first starting the pumps, the chiller will lock out on the No Flow alarm and require a manual reset to restart. This can be disruptive to the normal cooling process.
2. In areas where freeze-up is a concern, the chiller control senses the chilled water temperature and turns on an immersion heater in the evaporator. It also signals the chilled water pump to start, providing flow through the evaporator and additional protection against evaporator and outside pipe freeze-up. Other pump starting methods will not automatically provide this protection.

Note: The owner/operator must be aware that when the water temperature falls below freezing temperatures it is imperative NOT to stop the pump(s) as immediate freeze-up can occur.

This method of freeze protection is only effective as long as the facility and the chiller have power. The only positive freeze protection during power failures is to drain the evaporator and blow out each tube or add the appropriate concentration of glycol to the system.

Compressor VFD

Table 57: Compressor VFD Inspection Areas

| Inspection Area | Inspection Points | Corrective Action |
|-----------------------|--|--|
| General | Inspect equipment for discoloration from overheating or deterioration. | Replace damaged equipment as required. |
| | Inspect for dirt, foreign particles, or dust collection on components | Inspect door seal if so equipped. Use dry air to clear foreign matter. |
| Conductors and Wiring | Inspect wiring and connections for discoloration, damage or heat stress. | Repair or replace damaged wire. |
| Terminals | Inspect terminals for loose, stripped, or damaged connections. | Tighten loose screws and replace damaged screws or terminals. |
| Relays and Contactors | Inspect contactors and relays for excessive noise during operation. | Check coil voltage for over or under voltage condition. |
| | Inspect coils for signs of overheating such as melted or cracked insulation. | Replace damaged removable relays, contactors or circuit board. |

Table 58: Preventative Maintenance Schedule

| Operation | Weekly | Monthly (Note 1) | Annual (Note 2) |
|--|--------|------------------|-----------------|
| General | | | |
| Complete unit log and review (Note 3) | X | | |
| Inspect unit for loose or damaged components and visible leaks | | X | |
| Inspect thermal insulation for integrity | | | X |
| Clean and paint as required | | | X |
| Electrical (* including the VFDs) | | | |
| Sequence test controls * | | | X |
| Check contactors for pitting, replace as required * | | | X |
| Check terminals for tightness, tighten as necessary * | | | X |
| Verify solenoid plug(s) tightness and gasket integrity | | | X |
| Clean control panel interior * | | | X |
| Clean control box fan filter * (Note 7) | X | | |
| Visually inspect components for signs of overheating * | | X | |
| Verify compressor and oil heater operation | | X | |
| Refrigeration/Lubricant | | | |
| Leak test | | X | |
| Check liquid line sight glasses for clear flow | X | | |
| Check compressor oil sight glass for correct level (lubricant charge) | X | | |
| Check filter-drier pressure drop (Note 6) | | X | |
| Perform compressor vibration test (optional) | | | X |
| Perform oil analysis test on compressor oil | | | X |
| Condenser (air-cooled) | | | |
| Clean condenser coils (Note 4) | | | X |
| Check fan blades for tightness on shaft (Note 5) | | | X |
| Check fans for loose rivets and cracks, check motor brackets | | | X |
| Check coil fins for damage and straighten as necessary | | | X |
| For IWSE coils, torque all hose clamp connections to a minimum of 7 ft-lbs (84 in-lbs) | | | X |

NOTE: 1 Monthly operations include all weekly operations.

2 Annual (or spring startup) operations include all weekly and monthly operations.

3 Log readings can be taken daily for a higher level of observation.

4 Coil cleaning can be required more frequently in areas with a high level of airborne particles.

5 Be sure fan motors are electrically locked out.

6 Replace the filter if pressure drop exceeds 20 psi.

7 The weekly fan filter cleaning schedule can be modified to meet job conditions. It is important that the filter allows full air flow.

Definitions

Active Set Point

The active set point is the setting in effect at any given moment. This variation occurs on set points that can be altered during normal operation. Resetting the chilled water leaving temperature set point by one of several methods, such as return water temperature, is an example.

Active Capacity Limit

The active set point is the setting in effect at any given moment. Any one of several external inputs can limit a compressor's capacity below its maximum value.

Deadband

The deadband is a range of values surrounding a set point such that a change in the variable occurring within the deadband range causes no action from the controller. For example, if a temperature set point is 44°F and it has a deadband of ± 2°F, nothing will happen until the measured temperature is less than 42°F or more than 46°F.

DIN

Digital input, usually followed by a number designating the number of the input.

Error

In the context of this manual, "Error" is the difference between the actual value of a variable and the target setting or set point.

Evaporator Approach

The evaporator approach is calculated for each circuit.

$$\text{Evaporator Approach} = \text{LWT} - \text{Evap Saturated Temp}$$

Evap Recirc Timer

A timing function, with a 30-second default, that holds off any reading of chilled water for the duration of the timing setting. This delay allows the chilled water sensors (especially water temperatures) to take a more accurate reading of the chilled water system conditions.

EXV

Electronic expansion valve, used to control the flow of refrigerant to the evaporator.

Load Limit

An external signal from the keypad, the BAS or a 4-20 mA signal that limits the compressor loading to a designated percent of full load. Frequently used to limit unit power input.

Load Balance

Load balance is a technique that equally distributes the total unit load among the running compressors on a unit or group of units.

LWT

Leaving water temperature. The "water" is any fluid used in the chiller circuit.

ms

Millisecond

OAT

Outside ambient air temperature

Offset

Offset is the difference between the actual value of a variable (such as temperature or pressure) and the reading shown on the controller as a result of the sensor signal.

Refrigerant Saturated Temperature

Refrigerant saturated temperature is calculated from the pressure sensor readings for each circuit. The pressure is fitted to an R-134a temperature/pressure curve to determine the saturated temperature.

Soft Loading

Soft Loading is a configurable function used to ramp up the unit capacity over a given time period, usually used to influence building electrical demand by gradually loading the unit.

SP

Set point

Suction Superheat (SSH)

Suction superheat is calculated for each circuit using the following equation:

$$\text{Suction Superheat} = \text{Suction Temp} - \text{Evap Saturated Temp}$$

Stage Up/Down Accumulator - Fans

The accumulator can be thought of as a bank storing occurrences that indicate the need for an additional fan.

Stage up/Stage down Delta-T

Staging is the act of starting or stopping a compressor or fan when another is still operating. The Delta-T is the "deadband" on either side of the set point in which no action is taken.

Stage Up Delay

The time delay from the start of the first compressor to the start of the second.

Startup Delta-T

Number of degrees above the LWT set point required to start the first compressor.

Stop Delta-T

Number of degrees below the LWT set point required for the last compressor to stop.

Vdc

Volts, direct current



**DAIKIN APPLIED AMERICAS INC.
LIMITED PRODUCT WARRANTY
(North America)**

Daikin Applied Americas Inc. dba Daikin Applied (“Company”) warrants to contractor, purchaser and any owner of the product (collectively “Owner”) that Company, at its option, will repair or replace defective parts in the event any product manufactured by Company, including products sold under the brand name Daikin and used in the United States or Canada, proves defective in material or workmanship within twelve (12) months from initial startup or eighteen (18) months from the date shipped by Company, whichever occurs first. Authorized replaced parts are warranted for the duration of the original warranty. All shipments of such parts will be made FOB factory, freight prepaid and allowed. Company reserves the right to select carrier and method of shipment.

In addition, labor to repair or replace warranty parts is provided during Company normal working hours on products with rotary screw compressors and centrifugal compressors. Warranty labor is not provided for any other products.

Company’s liability to Owner under this warranty shall not exceed the lesser of the cost of correcting defects in the products sold or the original purchase price of the products.

PRODUCT STARTUP ON CENTRIFUGAL AND SCREW COMPRESSOR PRODUCTS IS MANDATORY and must be performed by a Daikin Applied or a Company authorized service representative.

It is Owner’s responsibility to complete and return the Registration and Startup Forms accompanying the product to Company within ten (10) days of original startup. If this is not done, the ship date and the startup date will be deemed the same for warranty period determination, and this warranty shall expire twelve (12) months from that date.

EXCEPTIONS

1. If free warranty labor is available as set forth above, such free labor does not include diagnostic visits, inspections, travel time and related expenses, or unusual access time or costs required by product location.
2. Refrigerants, fluids, oils and expendable items such as filters are not covered by this warranty.
3. This warranty shall not apply to products or parts which (a) have been opened, disassembled, repaired, or altered by anyone other than Company or its authorized service representative; or (b) have been subjected to misuse, negligence, accidents, damage, or abnormal use or service; or (c) have been operated, installed, or startup has been provided in a manner contrary to Company’s printed instructions, or (d) were manufactured or furnished by others and which are not an integral part of a product manufactured by Company; (e) have been exposed to contaminants, or corrosive agents, chemicals, or minerals, from the water supply source, or (f) have not been fully paid for by Owner.

ASSISTANCE

To obtain assistance or information regarding this warranty, please contact your local sales representative or a Daikin Applied office.

SOLE REMEDY

THIS WARRANTY CONSTITUTES THE OWNER’S SOLE REMEDY. IT IS GIVEN IN LIEU OF ALL OTHER WARRANTIES. THERE IS NO IMPLIED WARRANTY OF MERCHANTABILITY OR FITNESS FOR A PARTICULAR PURPOSE. IN NO EVENT AND UNDER NO CIRCUMSTANCE SHALL COMPANY BE LIABLE FOR INCIDENTAL, INDIRECT, SPECIAL, CONTINGENT OR CONSEQUENTIAL DAMAGES, WHETHER THE THEORY BE BREACH OF THIS OR ANY OTHER WARRANTY, NEGLIGENCE OR STRICT LIABILITY IN TORT.

No person (including any agent, sales representative, dealer or distributor) has the authority to expand the Company’s obligation beyond the terms of this express warranty or to state that the performance of the product is other than that published by Company.

For additional consideration, Company will provide an extended warranty(ies) on certain products or components thereof. The terms of the extended warranty(ies) are shown on a separate extended warranty statement.

Form No. 933-430285Y-01-A (05/17)



Daikin Applied Training and Development

Now that you have made an investment in modern, efficient Daikin Applied equipment, its care should be a high priority. For training information on all Daikin Applied HVAC products, please visit us at www.DaikinApplied.com and click on Training, or call 540-248-9646 and ask for the Training Department.

Warranty

All Daikin Applied equipment is sold pursuant to its standard terms and conditions of sale, including Limited Product Warranty. Consult your local Daikin Applied representative for warranty details. To find your local Daikin Applied representative, go to www.DaikinApplied.com.

Aftermarket Services

To find your local parts office, visit www.DaikinApplied.com or call 800-37PARTS (800-377-2787). To find your local service office, visit www.DaikinApplied.com or call 800-432-1342.

This document contains the most current product information as of this printing. For the most up-to-date product information, please go to www.DaikinApplied.com.

Products manufactured in an ISO Certified Facility.