

Group: **Chiller**

Part Number: **OMM1130-3**

Date: **August 2016**

## **Water-Cooled Scroll Compressor Chillers**

**WGZ030DW to WGZ200DW, Packaged Water-Cooled Chiller**

**WGZ030DA to WGZ200DA, Chiller with Remote Condenser**

**30 to 200 Tons, 105 to 700 kW**

**R-410a**

**50-60 Hertz**



# Table of Contents

|                                     |           |  |           |
|-------------------------------------|-----------|--|-----------|
| <b>Introduction .....</b>           | <b>3</b>  | <b>Using the Controller.....</b>       | <b>51</b> |
| General Description .....           | 3         | Menu Screens.....                      | 52        |
| Nomenclature .....                  | 3         | Menu Descriptions .....                | 53        |
| Water Pressure Drop .....           | 3         | <b>BAS Interface .....</b>             | <b>72</b> |
| Components .....                    | 6         | Parameter Details .....                | 73        |
| <b>Unit Configuration .....</b>     | <b>7</b>  | <b>Compressor Motor protection</b>     |           |
| Field Wiring Diagrams.....          | 8         | <b>Module.....</b>                     | <b>76</b> |
| Control Panel Layout .....          | 10        | <b>Optional Controls.....</b>          | <b>78</b> |
| Motor Protection Module.....        | 10        | Phase/Voltage Monitor (Optional) ..... | 78        |
| <b>Start-Up and Shutdown .....</b>  | <b>11</b> | Hot Gas Bypass (Optional) .....        | 78        |
| <b>Sequence of Operation .....</b>  | <b>13</b> | <b>System Maintenance .....</b>        | <b>79</b> |
| Start-up/Compressor Staging .....   | 13        | General.....                           | 79        |
| <b>MicroTech II Controller.....</b> | <b>17</b> | Electrical Terminals .....             | 79        |
| Controller Software Version.....    | 17        | POE Lubrication .....                  | 80        |
| General Description .....           | 17        | Sightglass and Moisture Indicator..... | 80        |
| Expansion I/O Controller .....      | 20        | Crankcase Heaters.....                 | 80        |
| Setpoints.....                      | 21        | Maintenance Schedule .....             | 81        |
| Automatic Adjusted Limits .....     | 23        | <b>System Service .....</b>            | <b>82</b> |
| Dynamic Defaults .....              | 24        | Troubleshooting Chart .....            | 84        |
| <b>Events &amp; Alarms .....</b>    | <b>24</b> | <b>Warranty Statement .....</b>        | <b>85</b> |
| Unit Stop Alarms.....               | 24        |  |           |
| Limit Events.....                   | 28        |  |           |
| <b>Controller Operation.....</b>    | <b>31</b> |  |           |
| EXV Control .....                   | 49        |  |           |

Products manufactured in an ISO Certified facility



Cover Picture: WGZ130DW without piping insulation installed for clarity

© 2016 Daikin Applied. Illustrations and data cover the Daikin Applied product at the time of publication and we reserve the right to make changes in design and construction at anytime without notice.

™® The following are trademarks or registered trademarks of their respective companies: BACnet from ASHRAE; LONMARK, LonTalk, LONWORKS, and the LONMARK logo are managed, granted and used by LONMARK International under a license granted by Echelon Corporation; Compliant Scroll from Copeland Corporation; Modbus from Schneider Electric; MicroTech II, Open Choices from Daikin Applied.

# Introduction

## General Description

Daikin Type WGZ water chillers are designed for indoor installations. Equipment room temperature for operating and standby conditions is 40°F to 122°F (4.4°C to 50°C). They are available with water-cooled condensers (Model DW), or arranged for use with remote air-cooled or evaporative condensers (Model DA). Each water-cooled unit is completely assembled and factory wired before evacuation, charging and testing. They consist of hermetic scroll compressors, brazed-plate evaporator, water-cooled condenser (WGZ-DW), and complete refrigerant piping.

Units manufactured for use with remote condensers (Models WGZ-DA) have all refrigerant specialties factory-mounted and connection points for refrigerant discharge and liquid lines.

Liquid line components that are included are manual liquid line shutoff valves, charging valves, filter-driers, liquid line solenoid valves, sight glass/moisture indicators, and thermal expansion valves. Other features include compressor crankcase heaters, and a MicroTech II™ microprocessor controller.

The electrical control center includes all equipment protection and operating controls necessary for dependable automatic operation.

**NOTE:** This manual contains information on the chiller unit control software operating with various refrigerants as follows:

- R-410A, used with the current “D” vintage of the WGZ chiller.
- R-134a, used with only with Model TGZ Templifiers. The operating manual devoted exclusively to Templifiers is OMM 1136.

## BOOT & BIOS

BOOT Version: 3.0F

BIOS Version 3.56

**Manuals:** Information in unit initial installation and routine maintenance is contained in Installation and Maintenance Manual IM 1131.

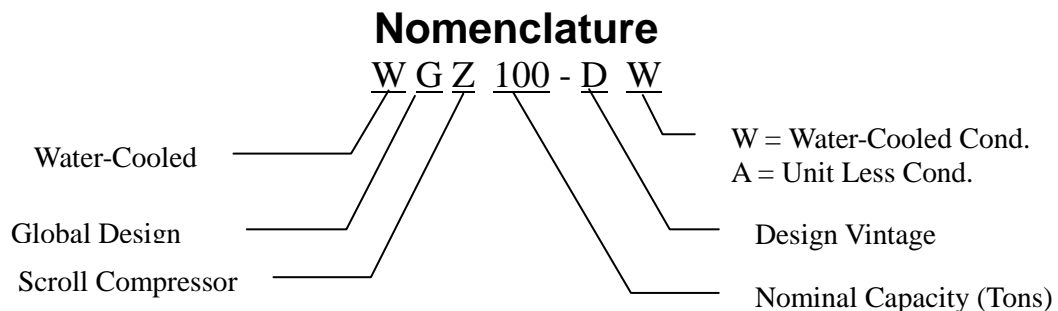

## Water Pressure Drop

Water flow rates should be maintained as closely as possible to job design values. The vessel flow rates must fall between the minimum and maximum values shown on the appropriate evaporator and condenser curves.

Measure the water pressure drop through the vessels at field-installed pressure taps and check the flow rate using the following tables. Do not include valves or strainers in these readings.

The evaporator flow rates and pressure drops shown on the following page are for full load design purposes. The maximum flow rate and pressure drop are based on a 6-degree temperature drop. Avoid higher flow rates with resulting lower temperature drops to prevent potential control problems resulting from very small control bands and limited start up/shut off temperature changes.

The minimum flow and pressure drop is based on a full load evaporator temperature drop of 16-degrees.

Figure 1, Evaporator Pressure Drop, WGZ030D – WGZ200D

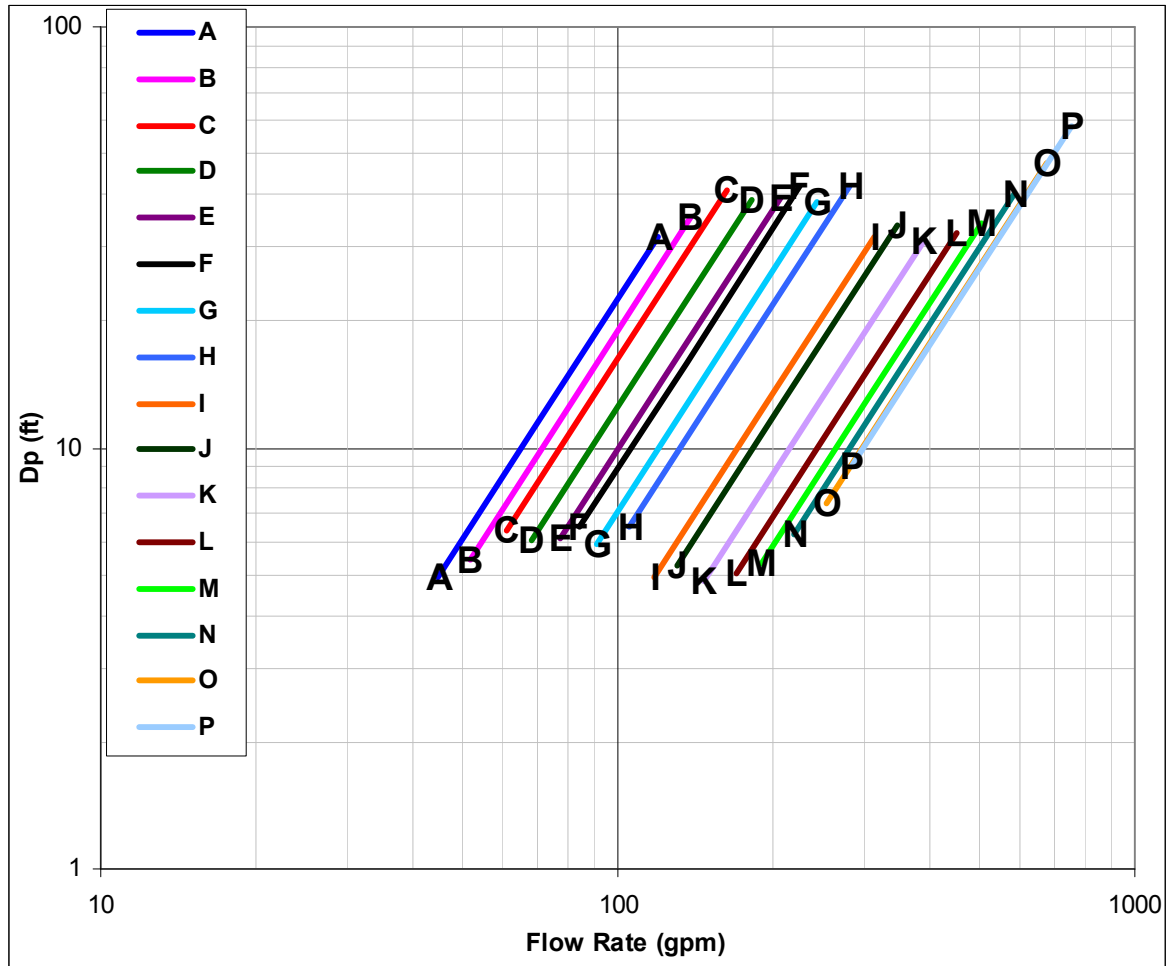

| Model   | Curve Ref | Minimum Flow & Pr. Drop |     |      |      | Nominal Flow & Pr. Drop |      |      |      | Maximum Flow & Pr. Drop |      |      |       |
|---------|-----------|-------------------------|-----|------|------|-------------------------|------|------|------|-------------------------|------|------|-------|
|         |           | Inch-Pound              |     | S.I. |      | Inch-Pound              |      | S.I. |      | Inch-Pound              |      | S.I. |       |
|         |           | GPM                     | Ft  | L/S  | kPa  | GPM                     | Ft   | L/S  | kPa  | GPM                     | Ft   | L/S  | kPa   |
| WGZ030D | A         | 45.0                    | 4.9 | 2.8  | 14.7 | 72.0                    | 12.0 | 4.5  | 35.9 | 120.0                   | 31.7 | 7.5  | 94.7  |
| WGZ035D | B         | 51.9                    | 5.4 | 3.2  | 16.3 | 83.0                    | 13.3 | 5.2  | 39.8 | 138.3                   | 35.1 | 8.6  | 104.9 |
| WGZ040D | C         | 61.1                    | 6.3 | 3.8  | 19.0 | 97.7                    | 15.5 | 6.1  | 46.3 | 162.8                   | 40.9 | 10.2 | 122.3 |
| WGZ045D | D         | 68.3                    | 6.0 | 4.3  | 18.0 | 109.2                   | 14.7 | 6.8  | 43.9 | 182.0                   | 38.8 | 11.4 | 116.0 |
| WGZ050D | E         | 77.1                    | 6.1 | 4.8  | 18.2 | 123.4                   | 14.9 | 7.7  | 44.5 | 205.7                   | 39.3 | 12.9 | 117.6 |
| WGZ055D | F         | 84.6                    | 6.5 | 5.3  | 19.3 | 135.4                   | 15.8 | 8.5  | 47.2 | 225.7                   | 41.7 | 14.1 | 124.7 |
| WGZ060D | G         | 90.8                    | 5.9 | 5.7  | 17.7 | 145.2                   | 14.5 | 9.1  | 43.3 | 242.0                   | 38.3 | 15.1 | 114.4 |
| WGZ070D | H         | 105.3                   | 6.5 | 6.6  | 19.3 | 168.5                   | 15.8 | 10.5 | 47.2 | 280.8                   | 41.7 | 17.6 | 124.7 |
| WGZ080D | I         | 117.4                   | 4.9 | 7.3  | 14.7 | 187.9                   | 12.0 | 11.7 | 35.9 | 313.2                   | 31.7 | 19.6 | 94.7  |
| WGZ090D | J         | 130.6                   | 5.2 | 8.2  | 15.7 | 209.0                   | 12.8 | 13.1 | 38.3 | 348.3                   | 33.8 | 21.8 | 101.0 |
| WGZ100D | K         | 146.7                   | 4.8 | 9.2  | 14.4 | 234.7                   | 11.8 | 14.7 | 35.3 | 391.2                   | 31.1 | 24.4 | 93.1  |
| WGZ115D | L         | 169.4                   | 5.0 | 10.6 | 15.1 | 271.0                   | 12.3 | 16.9 | 36.8 | 451.7                   | 32.5 | 28.2 | 97.0  |
| WGZ130D | M         | 190.1                   | 5.3 | 11.9 | 15.9 | 304.1                   | 13.0 | 19.0 | 38.9 | 506.8                   | 34.3 | 31.7 | 102.6 |
| WGZ150D | N         | 222.3                   | 6.2 | 13.9 | 18.6 | 355.7                   | 15.2 | 22.2 | 45.4 | 592.8                   | 40.1 | 37.1 | 119.9 |
| WGZ170D | O         | 253.9                   | 7.4 | 15.9 | 22.0 | 406.3                   | 18.0 | 25.4 | 53.8 | 677.2                   | 47.5 | 42.3 | 142.0 |
| WGZ200D | P         | 282.1                   | 9.0 | 17.6 | 26.9 | 451.4                   | 22.0 | 28.2 | 65.8 | 752.3                   | 58.1 | 47.0 | 173.6 |

Notes: Minimum, nominal, and maximum flows are at a 16° F, 10° F, and 6° F chilled water temperature range respectively at AHRI tons.

Figure 2, Condenser Pressure Drop, WGZ030D – WGZ200D

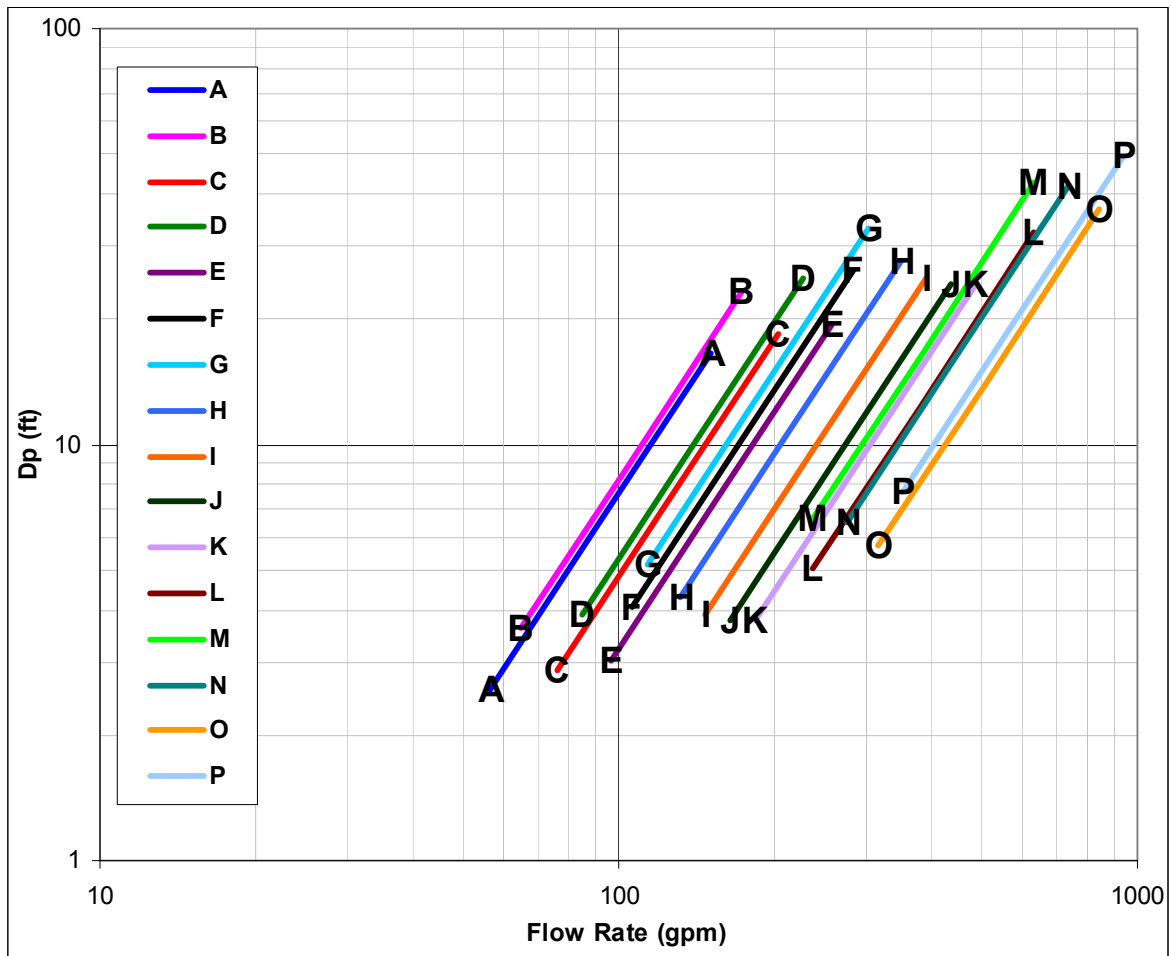

| Model   | Curve Ref | Minimum Flow & Pr. Drop |     |      |      | Nominal Flow & Pr. Drop |      |      |      | Maximum Flow & Pr. Drop |      |      |       |
|---------|-----------|-------------------------|-----|------|------|-------------------------|------|------|------|-------------------------|------|------|-------|
|         |           | Inch-Pound              |     | S.I. |      | Inch-Pound              |      | S.I. |      | Inch-Pound              |      | S.I. |       |
|         |           | GPM                     | Ft  | L/S  | kPa  | GPM                     | Ft   | L/S  | kPa  | GPM                     | Ft   | L/S  | kPa   |
| WGZ030D | A         | 56.3                    | 2.6 | 3.5  | 7.7  | 90.0                    | 6.3  | 5.6  | 18.8 | 150.0                   | 16.6 | 9.4  | 49.7  |
| WGZ035D | B         | 64.9                    | 3.6 | 4.1  | 10.8 | 103.8                   | 8.8  | 6.5  | 26.3 | 173.0                   | 23.2 | 10.8 | 69.4  |
| WGZ040D | C         | 76.3                    | 2.9 | 4.8  | 8.6  | 122.1                   | 7.0  | 7.6  | 20.9 | 203.5                   | 18.5 | 12.7 | 55.2  |
| WGZ045D | D         | 85.3                    | 3.9 | 5.3  | 11.6 | 136.5                   | 9.5  | 8.5  | 28.4 | 227.5                   | 25.1 | 14.2 | 74.9  |
| WGZ050D | E         | 96.4                    | 3.0 | 6.0  | 9.1  | 154.2                   | 7.4  | 9.6  | 22.1 | 257.0                   | 19.5 | 16.1 | 58.4  |
| WGZ055D | F         | 105.8                   | 4.1 | 6.6  | 12.1 | 169.2                   | 9.9  | 10.6 | 29.6 | 282.0                   | 26.1 | 17.6 | 78.1  |
| WGZ060D | G         | 113.4                   | 5.2 | 7.1  | 15.4 | 181.5                   | 12.6 | 11.3 | 37.7 | 302.5                   | 33.3 | 18.9 | 99.4  |
| WGZ070D | H         | 131.6                   | 4.3 | 8.2  | 12.8 | 210.6                   | 10.5 | 13.2 | 31.4 | 351.0                   | 27.7 | 21.9 | 82.8  |
| WGZ080D | I         | 146.8                   | 3.9 | 9.2  | 11.6 | 234.9                   | 9.5  | 14.7 | 28.4 | 391.5                   | 25.1 | 24.5 | 74.9  |
| WGZ090D | J         | 163.3                   | 3.8 | 10.2 | 11.3 | 261.3                   | 9.2  | 16.3 | 27.5 | 435.5                   | 24.3 | 27.2 | 72.6  |
| WGZ100D | K         | 183.4                   | 3.8 | 11.5 | 11.3 | 293.4                   | 9.2  | 18.3 | 27.5 | 489.0                   | 24.3 | 30.6 | 72.6  |
| WGZ115D | L         | 237.6                   | 5.0 | 14.8 | 15.1 | 380.1                   | 12.3 | 23.8 | 36.8 | 633.5                   | 32.5 | 39.6 | 97.0  |
| WGZ130D | M         | 237.6                   | 6.6 | 14.8 | 19.8 | 380.1                   | 16.2 | 23.8 | 48.4 | 633.5                   | 42.8 | 39.6 | 127.8 |
| WGZ150D | N         | 277.9                   | 6.5 | 17.4 | 19.3 | 444.6                   | 15.8 | 27.8 | 47.2 | 741.0                   | 41.7 | 46.3 | 124.7 |
| WGZ170D | O         | 317.4                   | 5.7 | 19.8 | 17.1 | 507.9                   | 14.0 | 31.7 | 41.8 | 846.5                   | 37.0 | 52.9 | 110.5 |
| WGZ200D | P         | 352.7                   | 7.7 | 22.0 | 23.0 | 564.3                   | 18.8 | 35.3 | 56.2 | 940.5                   | 49.6 | 58.8 | 148.3 |

# Components

**Figure 3, Compressor Locations**

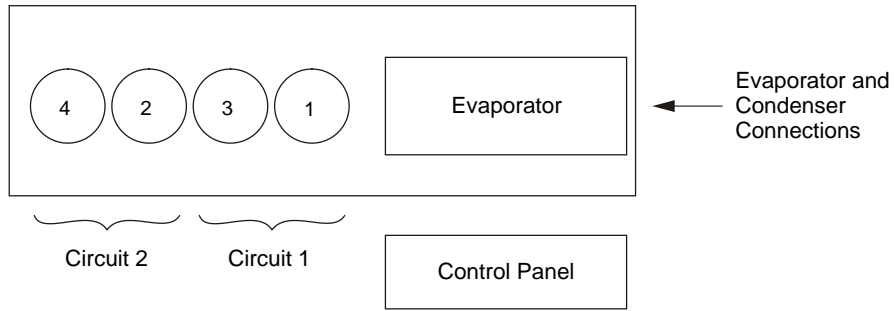

**NOTE:** Models WGZ150 to WGZ200 add a #5 compressor to circuit #1 and a #6 compressor to circuit #2.

# Unit Configuration

The chiller units have two refrigerant circuits, Models WGZ 030 to WGZ 130 have two tandem scroll compressors (total of four), a single two-circuited brazed plate evaporator, a single two-circuited water-cooled condenser, interconnecting refrigerant piping and a control panel with associated sensors and transducers.

Models WGZ 150 to WGZ 200 have two refrigerant circuits, two trio scroll compressors (total of six), a single two-circuited shell-and-tube evaporator, a single two-circuited water-cooled condenser, interconnecting refrigerant piping and a control panel with associated sensors and transducers.

**Figure 4, Schematic Piping Diagram (One of Two Circuits for WGZ030D – 130D)**

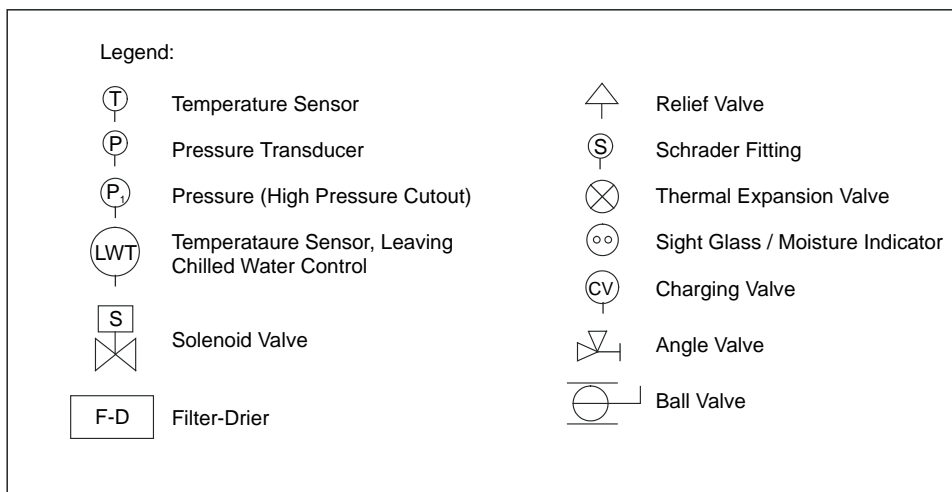
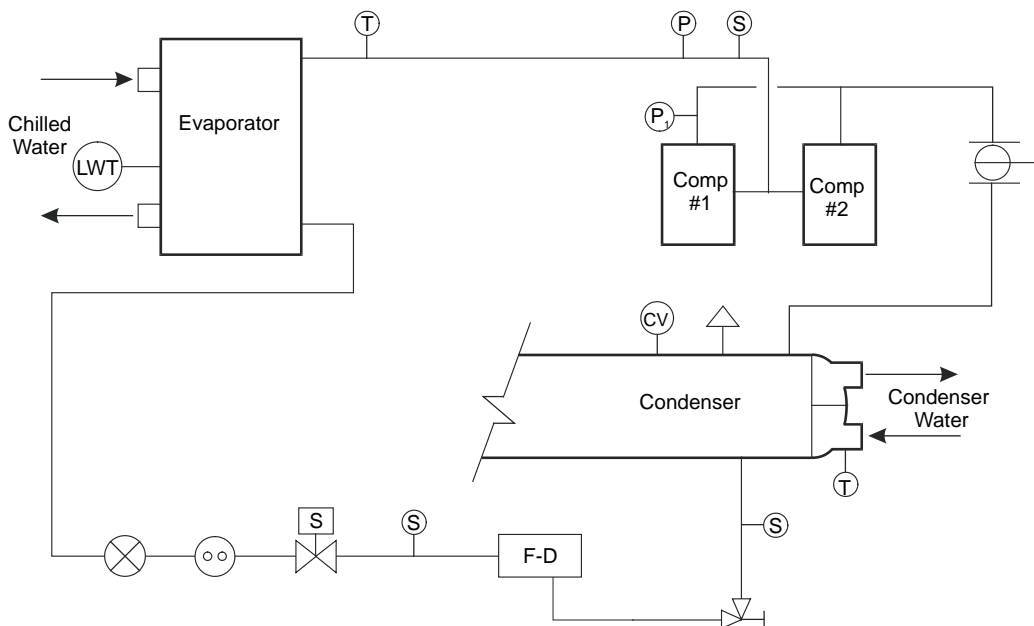

**NOTE:** WGZ 150 to WGZ 200 have a shell-and-tube evaporator, three compressors per circuit, and electronic expansion valves.

# Field Wiring Diagrams

Figure 5, WGZ030DW – WGZ200DW Field Wiring Diagram (Packaged Unit)

NOTE: ALL FIELD WIRING TO BE INSTALLED AS NEC CLASS 1 WIRING SYSTEM WITH CONDUCTOR RATED 600 VOLTS.

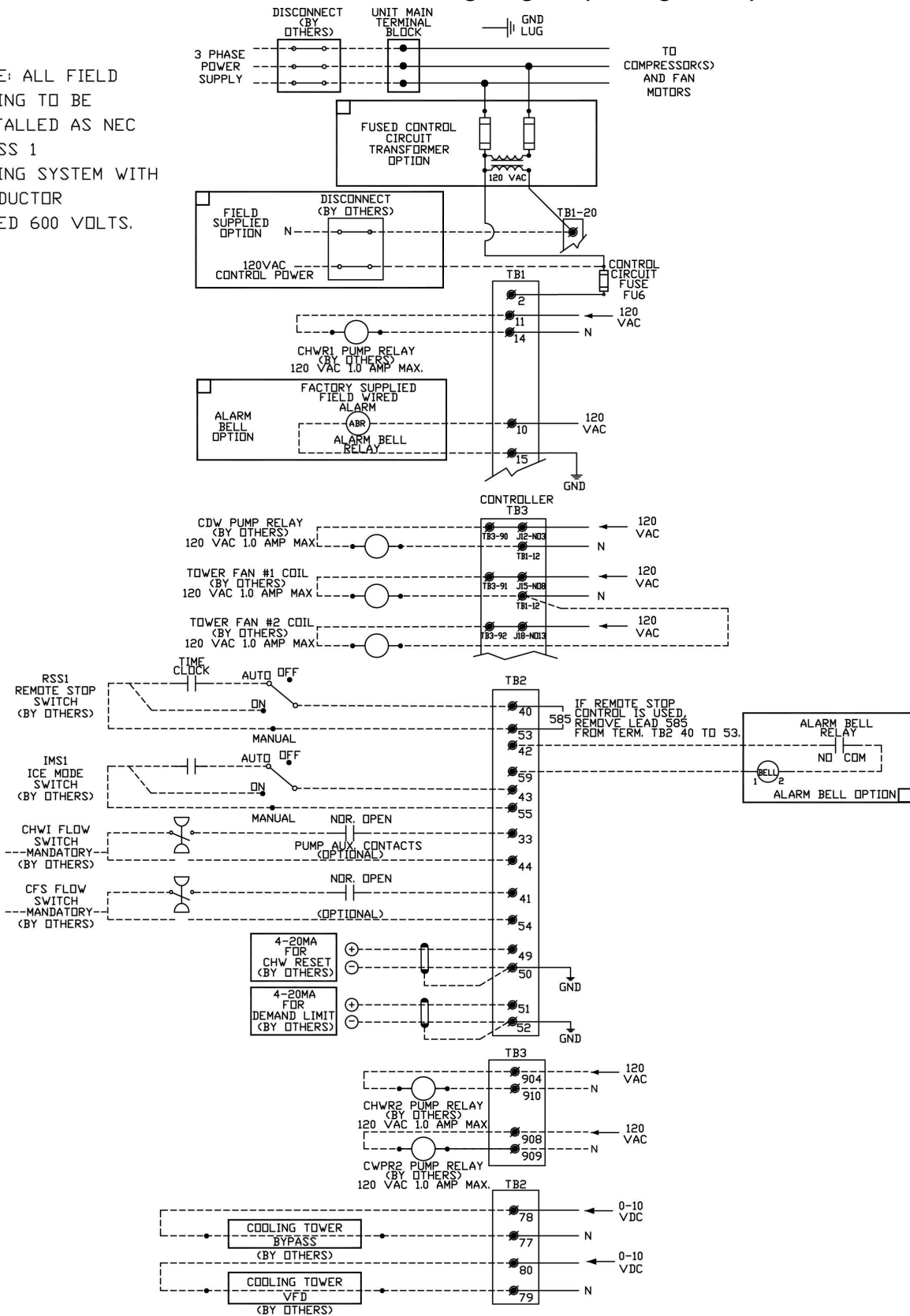



**Figure 6, WGZ030DA – WGZ200DA Field Wiring Diagram (Remote Condenser)**

NOTE: ALL FIELD WIRING TO BE INSTALLED AS NEC CLASS 1 WIRING SYSTEM WITH CONDUCTOR RATED 600 VOLTS.

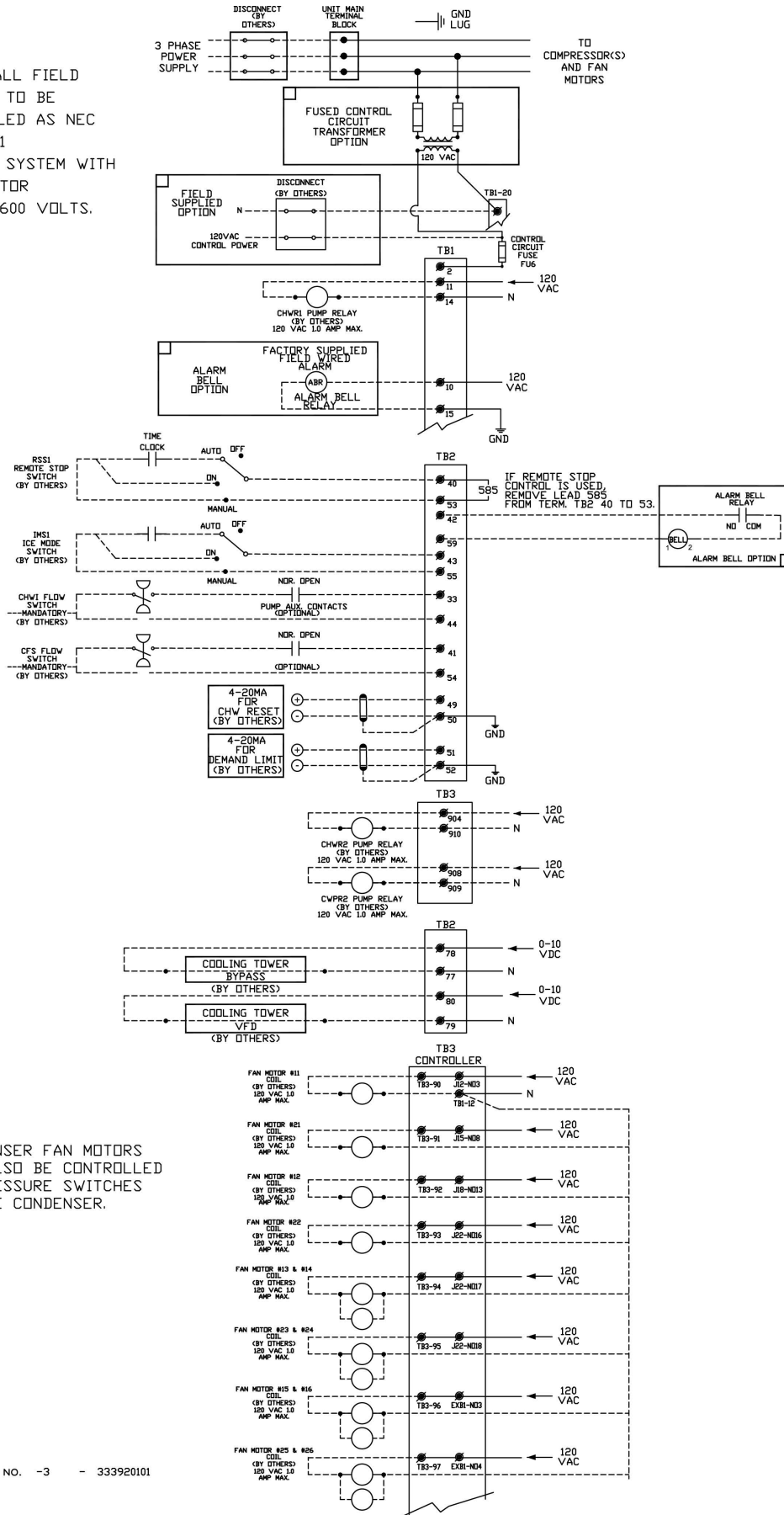

# Control Panel Layout

**Table 1, Typical Control Panel, 4-Compressor Unit**

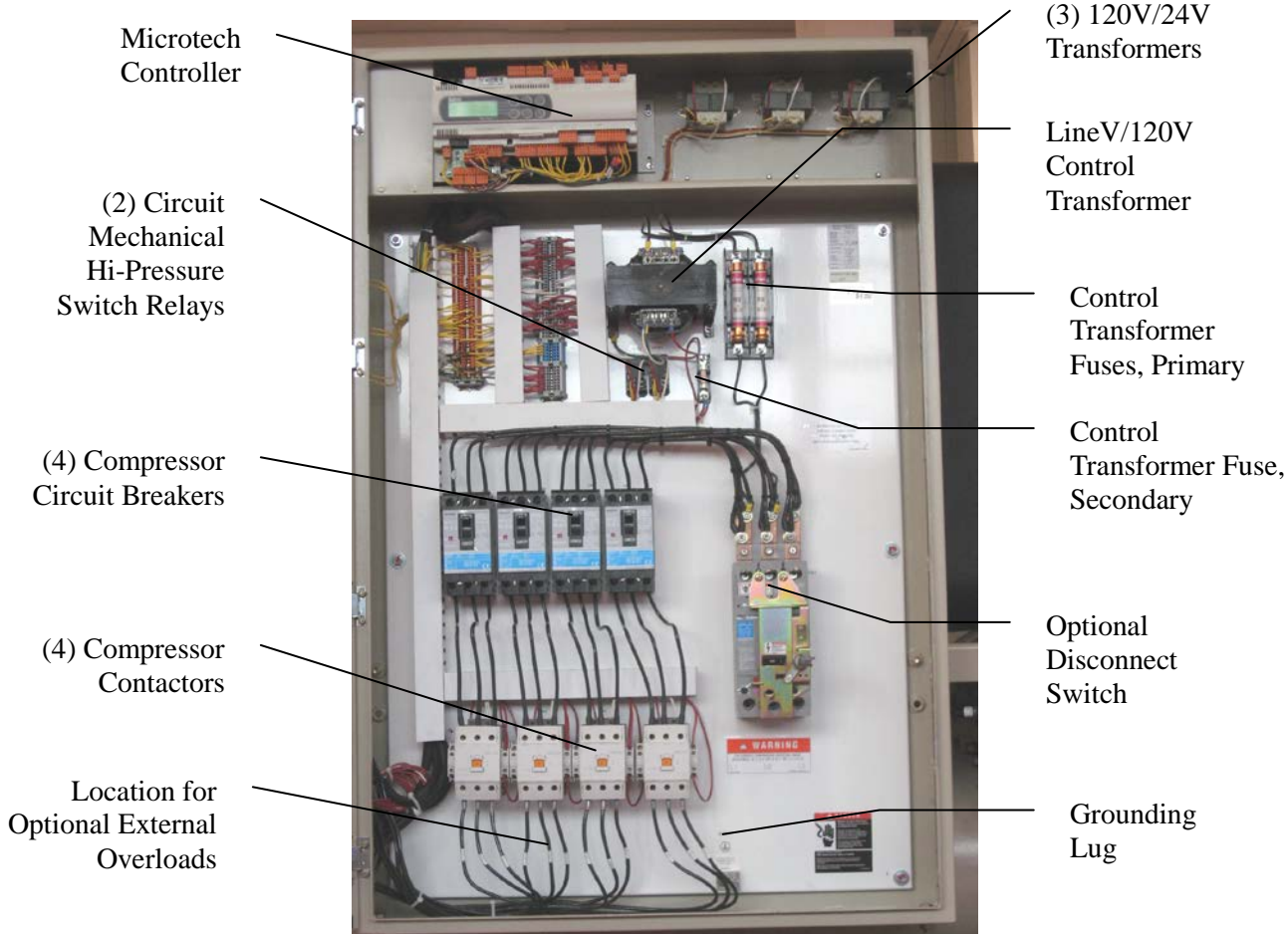

**NOTES:**

1. Additional space provided in the upper right section for optional multiple point power connection and optional circuit breakers.
2. Front door has a slot opening at the top for access to the MicroTech II controller for viewing display and making keypad entries without opening the panel door.

## Motor Protection Module

The motor protection system consists of an external control module, located on each compressor, motor terminal box, connected to a series of thermistors located in the motor windings and the compressor discharge port. If the windings experience an over-temperature condition or the discharge temperature is excessive, the module will trip and shut off the compressor.

**⚠ Warning**

Disconnect the compressor three-phase power before removing the terminal box cover Removal of the terminal box cover will expose the three-phase power connections. Contact with them can cause serious injury or death..

# Start-Up and Shutdown

---

## Pre Start-up

1. The chilled-water system should be flushed and cleaned. Proper water treatment is required to prevent corrosion and organic growth.
2. With main disconnect open, check all electrical connections in control panel and starter to be sure they are tight and provide good electrical contact. Although connections are tightened at the factory, they can loosen enough in shipment to cause a malfunction.
3. Check and inspect all water piping. Make sure flow direction is correct and piping is made to correct connection on evaporator and condenser.
4. Open all water flow valves to the condenser and evaporator.
5. Flush the cooling tower and system piping to be sure the system is clean. Start evaporator pump and manually start condenser pump and cooling tower. Check all piping for leaks. Vent the air from the evaporator and condenser water circuit, as well as from the entire water system. The cooler circuit should contain clean, treated, non-corrosive water.
6. Check to see that the evaporator water thermostat sensor is securely installed.
7. Making sure control stop switch S1 is open (off) and pumpdown switches PS1 and PS2 are on “manual pumpdown,” place the main power and control disconnect switches to “on.” This will energize the crankcase heaters. Wait a minimum of 12 hours before starting the unit.
8. Check compressor oil level. Prior to start-up, the oil level should cover at least one-third of the oil sight glass located in the equalizing line between the compressors or on the compressor.
9. Note the water pressure drop across evaporator and condenser on pages 4 and 5 and check that water flow is correct per the system design flow rates.
10. Check the actual line voltage to the unit to make sure it is the same as called for on the compressor nameplate, within + 10%, and that phase voltage unbalance does not exceed 3%. Verify that adequate power supply and capacity is available to handle load.
11. Make sure all wiring and fuses are of the proper size. Also make sure that all interlock wiring is completed per Daikin Applied diagrams.
12. Verify that all mechanical and electrical inspections by code authorities have been completed.
13. Make sure all auxiliary load and control equipment is operative and that an adequate cooling load is available for initial start-up.

## Start-up

1. Open the compressor discharge shutoff valves until backseated. Always replace valve seal caps.
2. Open the two manual liquid line shutoff valves.
3. Check to see that the unit circuit breakers are in the “off” position.
4. Check to see that the pumpdown switches, PS1 and PS2, are in the “manual pumpdown” position and the control system switch S1 is in the “off” position.
5. Put the main power and control circuit disconnects to the “on” position.
6. Verify crankcase heaters have operated for at least 12 hours prior to start-up. Crankcase should be warm to the touch.
7. Check that the MicroTech II controller is set to the desired chilled water temperature.
8. Start the system auxiliary equipment for the installation by turning on the time clock, ambient thermostat and/or remote on/off switch and water pumps.
9. Check resets of all equipment protection controls.
10. Switch on the unit circuit breakers.
11. Set pumpdown switches PS1 and PS2 to “auto” for restart and normal operation.

12. Start the system by setting the system switch S1 to on.
13. After running the unit for a short time, check the oil level in each compressor crankcase, rotation of condenser fans (if any), and check for flashing in the refrigerant sight glass.
14. After system performance has stabilized, it is necessary that the “Compressorized Equipment Warranty Form” (Form No. 206036A) be completed to establish commencement of the warranty period. Be sure to list the pressure drop across both vessels. This form is shipped with the unit and after completion should be returned to Daikin Applied service department through your sales representative.

### **Weekend or Temporary Shutdown**

Move pumpdown switches PS1 and PS2 to the “manual pumpdown” position. *After* the compressors have pumped down, turn off the chilled water pump. Note: With the unit in this condition, it will not restart until these switches are turned back on. The unit has one-time pumpdown. It is important that the compressors pump down before the water flow to the unit is interrupted to avoid freeze-up in the evaporator.

Leave S1 on and power to the unit so that the crankcase heaters will remain energized.

### **Start-up after Temporary Shutdown**

1. Start the water pumps.
2. With the control system switch S1 in the “on” position, move the pumpdown switches PS1 and PS2 to the “auto pumpdown” position.
3. Observe the unit operation for a short time, noting unusual sounds or possible cycling of compressors.
4. Check compressor crankcase heaters.

### **Extended Shutdown**

Close the manual liquid line shutoff valves.

After the compressors have pumped down, turn off the water pumps.

Turn off all power to the unit.

Move the control service switch S1 to the “off” position.

Close the discharge shutoff valves on the compressor(s) and the liquid outlet valves at the condenser.

Tag all opened disconnect switches to warn against start-up before opening the compressor suction and discharge valves.

Drain all water from the unit evaporator, condenser, and chilled water piping if the unit is to be shut down during the winter and exposed to below freezing temperatures. Do not leave the vessels or piping open to the atmosphere over the shutdown period.

### **Start-up after Extended Shutdown**

1. Inspect all equipment to see that it is in satisfactory operating condition.
2. Remove all debris that has collected on the surface of the condenser coils (remote condenser models) or check the cooling tower, if present.
3. Backseat the compressor discharge valves. Always replace valve seal caps.
4. Open the manual liquid line shutoff valves.
5. Check circuit breakers. They must be in the “off” position.
6. Check to see that the pumpdown switches PS1 and PS2 are in the “manual shutdown” position and the control system switch S1 is in the “off” position.
7. Put the main power and control circuit disconnects to the “on” position.
8. Allow the crankcase heaters to operate for at least 12 hours prior to start-up.
9. Start the chilled water pump and purge the water piping as well as the evaporator in the unit.
10. Start the system auxiliary equipment for the installation by turning on the time clock, ambient thermostat and/or remote on/off switch.

11. Check that the MicroTech II controller is set to the desired chilled water temperature.
12. Check resets of all equipment protection controls.
13. Switch the unit circuit breakers to “on.”
14. Start the system by setting the system switch S1 to “on.”

### CAUTION

Most relays and terminals in the control center are powered when S1 is closed and the control circuit disconnect is on. Therefore, do not close S1 until ready for start-up or serious equipment damage can occur.

15. Set pumpdown switches PS1 and PS2 to the “auto pumpdown” position for restart and normal operation.
16. After running the unit for a short time, check the oil level in the compressor oil sight glass or in the compressor’s equalizing lines for flashing, indicating possible refrigerant in the oil.

### **Low Ambient Start**

The low ambient start logic is for starting units with remote air-cooled condensers during periods of low ambient air temperatures.

A low ambient start takes place if the saturated condenser temperature is less than 85.0°F when the first compressor starts. The low ambient start is active for a time defined by the Low OAT Start Timer set point. This set point is found on screen three in the alarm set points menus.

During the low ambient start, the freezestat logic for the low-pressure stop alarm and the low-pressure events are disabled. The low-pressure stop alarm can still be triggered if the evaporator pressure drops below 5.0 psi at any time while the circuit is in the ‘Run’ state. Also, during the low ambient start, the second compressor is not allowed to start. The evaporator pressure is checked at the end of the low ambient start time frame. If the pressure is less than the Low Pressure Unload set point, then the low ambient start is not successful and the compressor will shut off. This will not be a manual reset alarm until three consecutive attempts have failed. The circuit alarm triggered after the third failed attempt is a Low OAT Restart fault. The Low OAT Restart faults are Circuit alarms so each circuit will attempt to start either compressor three times before the Low OAT Restart fault is indicated.

### **Fan High Ambient Rapid Start**

The following logic exists to get condenser fans started earlier than normal during unit starts with warm ambient air temperatures.

- If the outside air temperature higher than 75.0°F the condenser fan staging logic changes to bring on the first fan on when the condenser pressure is greater than 140 psi.
- The standard condenser fan staging logic would start the first condenser fan when the condenser pressure is higher than 200.0 psi.
- The last condenser fan on each circuit will not shut down until the condenser pressure drops below 140.0 psi regardless of the outside air temperature

## **Sequence of Operation**

---

The following sequence of operation is typical for WGZ water chiller models. The sequence can vary slightly depending upon options.

### **Compressor Heaters**

With the control circuit power on and the control stop switch S1 off, 115V power is applied through the control circuit fuse F1 to the compressor crankcase heaters HTR1, HTR2, HTR3, and HTR4.

### **Start-up/Compressor Staging**

**When compressors start and stop.**

**Stage Up Temp** is the LWT temperature at which the next compressor to start will stage up (start) after at least one compressor on the unit has started and is running.

**Start Up Temp** is the LWT at which the first compressor starts. The start up temperature equals the stage up temperature plus the Start Delta temperature. A high Start Delta will keep the unit off longer and reduce unit cycling at low loads. However, this high Start Delta will cause a larger excursion from the LWT setpoint before the unit starts.

Stated another way, the Start Delta is the number of degrees *above* the Evap LWT setpoint, plus ½ the Dead Band, that determines when the *first* compressor starts. The Start Delta is in effect for only the first start after *all* compressors have been off. Additional compressor starts and stops are determined by the LWT in respect to the dead band only. The dead band is automatically set at 30% of the EvapDeltaT selected in menu 3. The following sequence would occur for the settings shown below:

EvapDelta T=10.0°F Dead Band=3.0°F StartDelta=5.0°F StopDelta=2.0°F LWT=40.0°F

**Figure 7, Staging/Starting Temperatures**

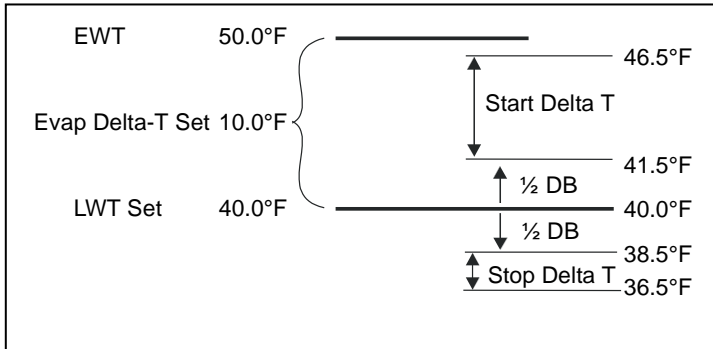

For a warm start-up (no compressors running), the first compressor will start at any temperature above 46.5°F. Each subsequent compressor will start after the Stage Up Timer has timed out and if the temperature is above the dead band, 41.5°F in this case.

If the LWT stays above 41.5°F, all of three (or 5) remaining compressors will eventually stage on after the Stage Up Timer times out between each stage.

At some point, the chilled water temperature will be dropping and begin to approach the point when compressors should begin staging off, which is the LWT setpoint minus ½ of the Dead Band, 38.5°F in this case. If the LWT remains below LWT setpoint minus ½ Dead Band and the Stage Down Timer times out, additional compressors will stage off. The *last* compressor will stage off when the LWT falls below the LWT Setpoint minus ½ the Dead Band minus the Stop Delta T. The stop Delta T is in effect for only the last compressor running.

If the temperature climbs above 38.5°F all running compressors will remain on. No compressor staging occurs within the Dead Band. The next-on compressor will start when the chilled water temperature reaches 41.5°F and the Stage Up Timer times out.

*However*, in some circumstances this methodology can cause the LWT to drop to dangerously low levels, with the evaporating temperature below the freeze point, before stopping. In the example shown in Figure 7, the Shutdown Temp (last compressor off) would be 36°F.

This would result in a refrigerant evaporating temperature approaching freezing, so the rule is amended to read:

If the Cool Leaving Water Temperature (LWT) set point is less than half the Control Band above 39.0° F the Stage Down temperature is calculated as:

*Stage Down Temperature* = Cool LWT – (Cool LWT - 39.0° F), and the

*Shutdown Temperature* = Cool LWT – (Cool LWT - 39.0° F) – Stop Delta T

This keeps the Stage Down Temp above 39°F and the Shutdown Temp above 36°F, as the maximum Stop Delta T allowed is 3-degrees.

**Which compressor starts and stops.** One compressor per circuit will start before starting the second compressor (or third) on any circuit. In other words, the compressor with the lowest number of starts will start first. The compressor with the lowest number of starts on the *other* circuit will start next, so that one compressor on each circuit will be running. The third compressor on will be the compressor on *either* circuit with the fewest starts. The remaining compressor will be the last on. If a circuit is unavailable for any reason, the second compressor on the operating circuit will stage on. Only two (or three) compressors (on the one circuit) will be operating.

There is a 150 second delay after power-up before any compressor is allowed to start.

When staging down, one compressor on each circuit will be left on until each circuit has only one compressor running. In other words, the compressor, on either circuit, with the most run-hours will stop first. The compressor with the most run-hours on the *other* circuit will stop next. One compressor on each circuit will be running. The third compressor off will be the one, on *either* circuit, with the most run-hours. The remaining compressor will be the last off. See the following description of pumpdown.

**Table 2, Staging in Cool and Glycol Mode**

| Description                      | Occurs When:   | Action Taken  |
|----------------------------------|--|---|
| Stage #1 ON<br>(See Notes Below) | Lvg Evap T > Evap LWT SP + (DB/2) + Startup Delta T                                  | Available compressor with least starts, ON                      |
| Stage #2 ON                      | After Stage Up Delay times out then, LVG Evap T > Evap LWT SP + (DB/2)               | Available compressor on the other circuit with least starts, ON |
| Stage #3 ON                      | After Stage Up Delay times out, then LVG Evap T > Evap LWT SP + (DB/2)               | Available compressor on either circuit with least starts, ON    |
| Stage #4 ON                      | After Stage Up Delay times out then, LVG Evap T > Evap LWT SP + (DB/2)               | Remaining compressor, ON  |
| Stage #4 OFF                     | After Stage Down Delay times out then, LVG Evap T < Evap LWT SP – (CB/2)             | Compressor with most run hours, OFF                             |
| Stage #3 OFF                     | After Stage Down Delay times out then, LVG Evap T < Evap LWT SP – (DB/2)             | Compressor on the other circuit with most run hours, OFF        |
| Stage #2 OFF                     | After Stage Down Delay times out then, LVG Evap T < Evap LWT SP – (DB/2)             | Compressor on either circuit with most run hours, OFF           |
| Stage #1 OFF                     | After Stage Down Delay times out then, LVG Evap T < Evap LWT SP – (DB/2)-StopDelta T | Remaining compressor, OFF                                       |

Note 1: DB (Dead Band) = Evap Water Delta T x .3

### Manual Compressor Disable Logic

Logic is available that allows the operator to manually enable and disable compressors. When a compressor is disabled, it is considered unavailable to start in the staging logic. This allows a damaged compressor to be taken offline while the remaining compressor can still provide some cooling

- The Compressor Disable set points are found on Compressor Set Points screens three and four.
- A running compressor cannot be disabled until it has been shutdown.
- If all of the compressors on a circuit are disabled, then the circuit will be disabled.
- If both circuits have all of their compressors disabled, then the Unit State will remain Off

### Automatic Pumpdown

WGZ units are equipped with single pumpdown control. When the last compressor running on either circuit is ready to shut off, the liquid line solenoid valve (LLSV) is closed first and the compressor continues to run until the pumpdown pressure is reached, at which time the compressor shuts off. The shut off pressure is set at 15 psi below the Low Evaporator pressure Unload setpoint.

When the first compressor on a circuit starts, the LLSV opens simultaneously.

### Manual Pumpdown

When the Pumpdown Switch is in the pumpdown position, all compressors except #1 and #2 will shut off. Then the Liquid Line and Hot Gas Bypass Valves will close. The operating compressor will pump out the refrigerant. When the Suction Pressure is at 40 psig, the compressors will stop.

### Chilled Water and Condenser Water Pumps

The chiller MicroTech II controller can be programmed to start and stop the system chilled water and condenser water pumps. They may also be controlled by the BAS or manually. Programming directions and the sequence of operation can be found beginning on page 38.

### Cooling Tower Control

The cooling tower fans and/or the tower bypass valve can be controlled by the MicroTech II controller. This provides a simple and direct method to control the unit's discharge pressure. Programming

directions and the sequence of operation can be found on page 65. Some means of discharge pressure control must be installed if the condenser water temperature can fall below 60°F (16°C).

## Condenser Fan Control

Model AC chillers equipped with air-cooled or evaporative-cooled condensers usually require some form of discharge pressure control. The MicroTech II controller can be programmed to provide this function by cycling condenser fans based on the unit discharge pressure. Directions on the pressure settings can be found on page 65. The following charts illustrate how four controller outputs can control six fan steps.

### Circuit 1

|         | Number of Fans = 4 |       |         | Number of fans = 6 |       |       |         | Number of fans = 8 |       |       |       |
|---------|--------------------|-------|---------|--------------------|-------|-------|---------|--------------------|-------|-------|-------|
| Stage # | Fan 1              | Fan 3 | Stage # | Fan 1              | Fan 3 | Fan 5 | Stage # | Fan 1              | Fan 3 | Fan 5 | Fan 7 |
| 1       | ON                 |       | 1       | ON                 |       |       | 1       | ON                 |       |       |       |
| 2       | ON                 | ON    | 2       | ON                 | ON    |       | 2       | ON                 | ON    |       |       |
|         |                    |       | 3       | ON                 | ON    | ON    | 3       | ON                 | ON    | ON    |       |
|         |                    |       |         |                    |       |       | 4       | ON                 | ON    | ON    | ON    |

|         | Number of fans = 8 |       |         |         | (R410A)Number of fans = 10 |       |         |       |         | (R410A)Number of fans = 12 |       |         |          |
|---------|--------------------|-------|---------|---------|----------------------------|-------|---------|-------|---------|----------------------------|-------|---------|----------|
| Stage # | Fan 1              | Fan 3 | Fan 5&7 | Stage # | Fan 1                      | Fan 3 | Fan 5&7 | Fan 9 | Stage # | Fan 1                      | Fan 3 | Fan 5&7 | Fan 9&11 |
| 1       | ON                 |       |         | 1       | ON                         |       |         |       | 1       | ON                         |       |         |          |
| 2       | ON                 | ON    |         | 2       | ON                         | ON    |         |       | 2       | ON                         | ON    |         |          |
| 3       | ON                 |       | ON      | 3       | ON                         |       | ON      |       | 3       | ON                         |       | ON      |          |
| 4       | ON                 | ON    | ON      | 4       | ON                         | ON    | ON      |       | 4       | ON                         | ON    | ON      |          |
|         |                    |       |         | 5       | ON                         | ON    | ON      | ON    | 5       | ON                         |       | ON      | ON       |
|         |                    |       |         |         |                            |       |         |       | 6       | ON                         | ON    | ON      | ON       |

### Circuit 2

|         | Number of Fans = 4 |       |         | Number of fans = 6 |       |       |         | Number of fans = 8 |       |       |       |
|---------|--------------------|-------|---------|--------------------|-------|-------|---------|--------------------|-------|-------|-------|
| Stage # | Fan 2              | Fan 4 | Stage # | Fan 2              | Fan 4 | Fan 6 | Stage # | Fan 2              | Fan 4 | Fan 6 | Fan 8 |
| 1       | ON                 |       | 1       | ON                 |       |       | 1       | ON                 |       |       |       |
| 2       | ON                 | ON    | 2       | ON                 | ON    |       | 2       | ON                 | ON    |       |       |
|         |                    |       | 3       | ON                 | ON    | ON    | 3       | ON                 | ON    | ON    |       |
|         |                    |       |         |                    |       |       | 4       | ON                 | ON    | ON    | ON    |

|         | Number of fans = 8 |       |         |         | (R410A)Number of fans = 10 |       |         |        |         | (R410A)Number of fans = 12 |       |         |           |
|---------|--------------------|-------|---------|---------|----------------------------|-------|---------|--------|---------|----------------------------|-------|---------|-----------|
| Stage # | Fan 2              | Fan 4 | Fan 6&8 | Stage # | Fan 2                      | Fan 4 | Fan 6&8 | Fan 10 | Stage # | Fan 2                      | Fan 4 | Fan 6&8 | Fan 10&12 |
| 1       | ON                 |       |         | 1       | ON                         |       |         |        | 1       | ON                         |       |         |           |
| 2       | ON                 | ON    |         | 2       | ON                         | ON    |         |        | 2       | ON                         | ON    |         |           |
| 3       | ON                 |       | ON      | 3       | ON                         |       | ON      |        | 3       | ON                         |       | ON      |           |
| 4       | ON                 | ON    | ON      | 4       | ON                         | ON    | ON      |        | 4       | ON                         | ON    | ON      |           |
|         |                    |       |         | 5       | ON                         | ON    | ON      | ON     | 5       | ON                         |       | ON      | ON        |
|         |                    |       |         |         |                            |       |         |        | 6       | ON                         | ON    | ON      | ON        |

## ICE

In ICE mode, the compressors stage to 100% load until the LWT is less than the ICE LWT SP. Then Compressors #3 and #4 shut down. Following that, Compressors #1 and #2 shut down after going through normal pumpdown on both circuits. There is a programmable, start-to-start, Ice Mode Start Delay that limits the frequency of starts when in the ice mode. The timer can be manually cleared to force a restart.



# MicroTech II Controller

---

## Controller Software Version

This manual is based on software version WGZD20102F. The “02F” is the version descriptor. The version installed in a unit can be viewed by pressing the MENU and ENTER keys simultaneously, then pressing MENU to return to the regular menu screen.

## General Description

The MicroTech II controller’s state-of-the-art design will not only permit the chiller to run more efficiently but will also simplify troubleshooting if a system failure occurs. Every MicroTech II controller is programmed and tested prior to shipment to assist in a trouble-free start-up. The MicroTech II controller can be used to cycle fans on remote air-cooled condensers for head pressure control when the setpoint Water Cooled=N is selected in one of the setpoint menu screens. Water Cooled=Y sets the chiller for operation with the water-cooled condenser.

## Operator Friendly

The MicroTech II controller menu structure is separated into three distinct categories, which provide the operator or service technician with a full description of

1. current unit status,
2. control parameters (setpoints)
3. alarms. Security protection prevents unauthorized changing of the setpoints and control parameters.

The MicroTech II controller continuously performs self-diagnostic checks, monitoring all system temperatures, pressures and protection devices, and will automatically shutdown a compressor, a refrigerant circuit or the entire unit should a fault occur. The cause of the shutdown and date stamp are retained in memory and can be easily displayed in plain English for operator review, which is an extremely useful feature for troubleshooting. In addition to displaying alarm diagnostics, the MicroTech II chiller controller also provides the operator with a warning of pre-alarm conditions.

## Staging

The four scroll (or six) compressors are staged on and off as a function of leaving chilled water temperature, number of starts and run-hours. See Sequence of Operation.

## Equipment Protection

The unit is protected by alarms that shut it down and require manual reset, and also by limit alarms that limit unit operation in response to some out-of-limit condition. Shut down alarms activate an alarm signal that can be wired to a remote device.

## Unit Enable Selection

Enables unit operation from local keypad or digital input

## Unit Mode Selection

Selects standard cooling, ice, glycol, or test operation mode

## Keypad/Display

A 4-line by 20-character/line liquid crystal display and 6-key keypad is mounted on the unit controller. Its layout is shown below.

**Figure 8, Keypad and Display in MENU Mode**

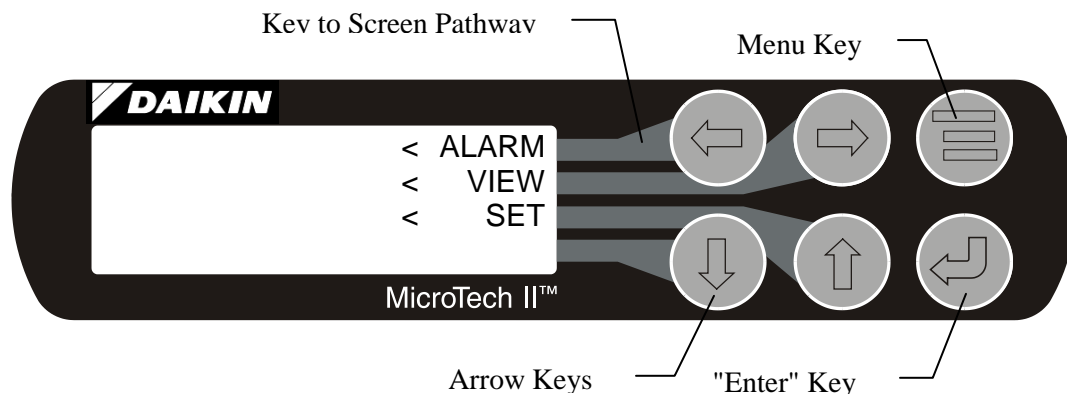

The four arrow keys (UP, DOWN, LEFT, RIGHT) have three modes of use.

Scroll between data screens as indicated by the arrows (default mode).

Select a specific data screen in a hierarchical fashion using dynamic labels on the right side of the display (this mode is entered by pressing the MENU key).

Change field values in edit mode according to the following table:

|      |           |       |           |
|------|-----------|-------|-----------|
| LEFT | Default   | RIGHT | Cancel    |
| UP   | Increment | DOWN  | Decrement |

These four edit functions are indicated by one-character abbreviation on the right side of the display (this mode is entered by pressing the ENTER key).

## Inputs/Outputs

**Table 3, Analog Inputs**

C1 = Refrigerant Circuit #1, C2 = Refrigerant Circuit #2, UT = Unit, \*n = Refrig. Dependent

| #  | Description  | Type | Signal Source                | Range          |
|----|--|------|------------------------------|----------------|
| *1 | Evaporator Refrigerant Pressure #1 (R1342)   | C1   | 0.1 to 0.9 VDC               | 0 to 132 psi   |
| *1 | Evaporator Refrigerant Pressure #1 (R410a)   | C1   | 0.1 to 0.9 VDC               | 0 to 350 psi   |
| *2 | Evaporator Refrigerant Pressure #2 (R134a)   | C2   | 0.1 to 0.9 VDC               | 0 to 132 psi   |
| *2 | Evaporator Refrigerant Pressure #2 (R410a)   | C2   | 0.1 to 0.9 VDC               | 0 to 350 psi   |
| *3 | Condenser Refrigerant Pressure #1 (R134a)  | C1   | 0.1 to 0.9 VDC               | 3.6 to 410 psi |
| *3 | Condenser Refrigerant Pressure #1 (R410a)  | C1   | 0.1 to 0.9 VDC               | 0 to 700 psi   |
| 4  | Leaving Evaporator Water Temperature   | UT   | NTC Thermister<br>(10k@25°C) | -58 to 212°F   |
| 5  | Condenser Entering Water Temperature or Outside Ambient Temperature (See Note below) | UT   | NTC Thermister<br>(10k@25°C) | -58 to 212°F   |
| *6 | Condenser Refrigerant Pressure #2 (R134a)  | C2   | 0.1 to 0.9 VDC               | 3.6 to 410 psi |
| *6 | Condenser Refrigerant Pressure #2 (R410a)  | C2   | 0.1 to 0.9 VDC               | 0 to 700 psi   |
| 7  | Reset of Leaving Water Temperature   | UT   | 4-20 mA Current              | 0-(10 to 80°F) |
| 8  | Demand Limit (R410A)   | UT   | 4-20 mA Current              | 0-100 % Load   |
| 9  | Compressor Suction Temperature #1  | C1   | NTC Thermister<br>(10k@25°C) | -58 to 212°F   |
| 10 | Compressor Suction Temperature #2  | C2   | NTC Thermister<br>(10k@25°C) | -58 to 212°F   |

### Notes:

1. If Water Cooled = Y, then Entering Condenser. If Water Cooled = N, then Outside Ambient.
2. Selection of R134a in unit setpoint screen will modify unit operation for Tempifier application.

**Table 4, Analog Outputs**

| # | Description                           | Output Signal | Range          |
|---|---------------------------------------|---------------|----------------|
| 1 | Cooling Tower Bypass Valve Position   | 0 to 10 VDC   | 0 to 100% Open |
| 2 | Cooling Tower VFD Speed               | 0 to 10 VDC   | 0 to 100%      |
| 3 | Circuit #1 Electronic Expansion Valve | 0 to 10 VDC   | 0 to 100%      |
| 4 | Circuit #2 Electronic Expansion Valve | 0 to 10 VDC   | 0 to 100%      |

**NOTE:** Analog outputs 3 & 4 are for R410A and R134a units only.

**Table 5, Digital Inputs**

The following parameters are digital inputs to this controller.

C1 = Refrigerant Circuit #1, C2 = Refrigerant Circuit #2, UT = Unit, \*n = Refrigerant Dependent

| #   | Description                               | Type | Signal          | Signal            |
|-----|---|------|-----------------|-------------------|
| 1   | Unit OFF Switch                           | UT   | 0 VAC (Stop)    | 24 VAC (Auto)     |
| 2   | Pump Down Switch #1                       | C1   | 0 VAC (Stop)    | 24 VAC (Start)    |
| 3   | Evaporator Water Flow Switch              | UT   | 0 VAC (No Flow) | 24 VAC (Flow)     |
| *4  | Motor Protection #1                       | C1   | 0 VAC (Fault)   | 24 VAC (No Fault) |
| *4  | Open                                      |      |                 |                   |
| 5   | Open                                      |      |                 |                   |
| 6   | Pump Down Switch #2                       | C2   | 0 VAC (Stop)    | 24 VAC (Start)    |
| *7  | Motor Protection #2                       | C2   | 0 VAC (Fault)   | 24 VAC (No Fault) |
| *7  | Open                                      |      |                 |                   |
| *8  | Open                                      |      |                 |                   |
| *8  | Condenser Water Flow Switch (R134a,R410a) | UT   | 0 VAC (No Flow) | 24 VAC (Flow)     |
| 9   | Phase Voltage Fault #1 (See Note 1 Below) | C1   | 0 VAC (Fault)   | 24 VAC (No Fault) |
| 10  | Phase Voltage Fault #2 (See Note 1 Below) | C2   | 0 VAC (Fault)   | 24 VAC (No Fault) |
| 11  | Ground Fault Prot. #1 (See Note 2 Below)  | C1   | 0 VAC (Fault)   | 24 VAC (No Fault) |
| 12  | Ground Fault Prot. #2 (See Note 2 Below)  | C2   | 0 VAC (Fault)   | 24 VAC (No Fault) |
| 13  | Remote Start/Stop                         | UT   | 0 VAC (Stop)    | 24 VAC (Start)    |
| *14 | Condenser Water Flow Switch               | UT   | 0 VAC (No Flow) | 24 VAC (Flow)     |
| *14 | Open (                                    |      |                 |                   |
| *15 | Open                                      |      |                 |                   |
| *15 | Motor Protection #1 (R134a,R410a)         | C1   | 0 VAC (Fault)   | 24 VAC (No Fault) |
| *16 | Open                                      |      |                 |                   |
| *16 | Motor Protection #2 (R134a,R410a)         | C2   | 0 VAC (Fault)   | 24 VAC (No Fault) |
| 17  | Ice Mode Switch                           | UT   | 0 VAC (Normal)  | 24 VAC (Ice)      |
| 18  | Heat Mode Switch                          | UT   | 0 VAC (Normal)  | 24 VAC (Heat)     |

**Notes:**

- See Safety Alarms Table for "Phase Voltage Protection". Units with single point electrical connection will have one PVM with Inputs 9 and 10 wired together. Units with multiple point connection will have two PVM's with Input 9 for Electrical Circuit #1 and Input 10 for Electrical Circuit #2.
- See Safety Alarms Table for "Ground Fault Protection". Units with single point electrical connection will have one GFP with Inputs 11 and 12 wired together. Units with multiple point connection will have two GFP's with Input 11 for Electrical Circuit #1 and Input 12 for Electrical Circuit #2.

**Table 6, Digital Outputs**

The following parameters are digital outputs from this controller.

C1 = Refrigerant Circuit #1, C2 = Refrigerant Circuit #2, UT = Unit, \*n = Refrigerant Dependent

| # | Description  | Type     | Load                             | Output OFF     | Output ON     |
|---|--|----------|----------------------------------|----------------|---------------|
| 1 | Alarm  | C1,C2,UT | Alarm Indicator                  | Alarm OFF      | Alarm ON      |
| 2 | Evaporator Water Pump  | UT       | Pump Contactor                   | Pump OFF       | Pump ON       |
| 3 | Condenser Fan #1 – Water Cooled = N /<br>Condenser Water Pump – Water Cooled = Y | C1 / UT  | Fan Contactor/<br>Pump Contactor | Fan OFF        | Fan ON        |
| 4 | Motor Control Relay #1 = Compr#1   | C1       | Starter                          | Compressor OFF | Compressor ON |

Continued next page.

**Table 6, Continued**

| #   | Description   | Type    | Load          | Output OFF     | Output ON     |
|-----|---|---------|---------------|----------------|---------------|
| 5   | Motor Control Relay #3 = Compr#3                                | C1      | Starter       | Compressor OFF | Compressor ON |
| *6  | Condenser Fan #3- Water Cooled =N /Tower Fan #2-Water Cooled=Y  | C1 / UT | Fan Contactor | Fan OFF        | Fan ON        |
| *6  | Motor Control Relay #5 = Compr#5 (R134a,R410a)                  | C1      | Starter       | Compressor OFF | Compressor ON |
| 7   | Liquid Line #1  | C1      | Solenoid      | Cooling OFF    | Cooling ON    |
| 8   | Condenser Fan #2 – Water Cooled =N /Tower Fan #1-Water Cooled=Y | C2 / UT | Fan Contactor | Fan OFF        | Fan ON        |
| 9   | Motor Control Relay #2 = Compr#2                                | C2      | Starter       | Compressor OFF | Compressor ON |
| 10  | Motor Control Relay #4 = Compr#4                                | C2      | Starter       | Compressor OFF | Compressor ON |
| *11 | Condenser Fan #4  | C2      | Fan Contactor | Fan OFF        | Fan ON        |
| *11 | Motor Control Relay #6 = Compr#6 (R134a,R410a)                  | C2      | Starter       | Compressor OFF | Compressor ON |
| 12  | Liquid Line #2  | C2      | Solenoid      | Cooling OFF    | Cooling ON    |
| 13  | Condenser Fan #5  | C1      | Fan Contactor | Fan OFF        | Fan ON        |
| 14  | Hot Gas Bypass #1   | C1      | Solenoid      | Cooling OFF    | Cooling ON    |
| 15  | Hot Gas Bypass #2   | C2      | Solenoid      | Cooling OFF    | Cooling ON    |
| *16 | Condenser Fan #6  | C2      | Fan Contactor | Fan OFF        | Fan ON        |
| *16 | Condenser Fan #4  | C2      | Fan Contactor | Fan OFF        | Fan ON        |
| *17 | Condenser Fan #7  | C1      | Fan Contactor | Fan OFF        | Fan ON        |
| *17 | Condenser Fan #5&7 (R134a,R410a)                                | C1      | Fan Contactor | Fan OFF        | Fan ON        |
| 18  | Condenser Fan #8  | C2      | Fan Contactor | Fan OFF        | Fan ON        |
| 18  | Condenser Fan #6&8  | C2      | Fan Contactor | Fan OFF        | Fan ON        |

## Expansion I/O Controller

### Digital Outputs

The following parameters are digital outputs from this controller.

Types: C1 = Refrigerant Circuit #1, C2 = Refrigerant Circuit #2, UT = Unit

| # | Description               | Type | Output Off | Output On |
|---|---------------------------|------|------------|-----------|
| 1 | Evap Water Pump Output #2 | UT   | Pump Off   | Pump On   |
| 2 | Cond Water Pump Output #2 | UT   | Pump Off   | Pump On   |
| 3 | Condenser Fan #9          | C1   | Fan OFF    | Fan ON    |
| 4 | Condenser Fan #10         | C2   | Fan OFF    | Fan ON    |

### Analog Inputs

The following parameters are digital outputs from this controller for Templifier operation only.

Types: C1 = Refrigerant Circuit #1, C2 = Refrigerant Circuit #2, & UT = Unit

| # | Description                                   | Type | Output Off                | Output On    |
|---|---|------|---------------------------|--------------|
| 1 | Entering Evaporator Water Temperature (R134a) | UT   | NTC Thermister (10k@25°C) | -58 to 212°F |
| 2 | Demand Limit (R134a)                          | UT   | 4-20 mA Current           | 0-100 % Load |
| 3 | Liquid Line Temperature #1 (R134a)            | C1   | NTC Thermister (10k@25°C) | -58 to 212°F |
| 4 | Liquid Line Temperature #2 (R134a)            | C2   | NTC Thermister (10k@25°C) | -58 to 212°F |

# Setpoints

The following parameters are remembered during power off, are factory set to the **Default** value, and can be adjusted to any value in the **Range** column.

The **PW** (password) column indicates the password level that must be active in order to change the setpoint. Passwords are as follows:

O = Operator [0100]      M = Manager [2001]

**Table 7, Setpoints (setpoints with \* are set at Daikin Applied factory)**

| Description   | Default  | Range  | PW |
|---|----------|--|----|
| Unit Enable   | Off      | Off, On  | O  |
| *Unit Mode (R407C, R410A)                                 | Cool     | Cool, Cool w/Glycol, Ice w/Glycol, Test  | O  |
| Unit Mode (R134a)   | Cool     | Cool, Cool w/Glycol, Heat, Test  |    |
| Control source  | Switches | Keypad, Network, Switches  | O  |
| *Available Modes (R407C,R410A)                            | Cool     | Cool, Cool w/Glycol, Cool/Ice w/Glycol<br>Ice w/Glycol, Test   | M  |
| *Available Modes (R134a)                                  | Cool     | Test, Cool, Cool w/Glycol, Cool/Heat, COOL/HEAT<br>w/Glycol, Heat w/Glycol,  | M  |
| Evap LWT  | 44.0 °F  | Without Glycol: 40.0 to 60.0°F<br>40.0 to 85.0°F (R134a Only)<br>With Glycol: 20.0 to 60.0°F (R407C)<br>10.0 to 60.0°F (R410A)<br>20.0 to 85.0°F (R134a) | O  |
| Ice LWT   | 40.0 °F  | 15.0 to 40.0 °F  | O  |
| Heat LWT (R134a only)                                     | 110.0°F  | 110 to 165°F   | O  |
| Evap Delta T  | 10.0 °F  | 6.0 to 16.0 °F   | O  |
| Startup Delta T   | 10.0 °F  | 1.0 to 15.0 °F   | O  |
| Stop Delta T  | 0.5 °F   | 0 to 3.0 °F  | O  |
| Max Pulldown Rate   | 1.0 °F   | 0.5 to 5.0 °F  | M  |
| Evap Recirculate Timer                                    | 30       | 15 to 300 seconds  | M  |
| Evap Pump<br>(Refrigerant = R410a,R134a)                  | #1 Only  | #1 Only, #2 Only, Auto, #1 Prim,<br>#2 Prim  | M  |
| Cond Delta T (R134a only)                                 | 20.0°F   | 5.0 to 40.0°F  |    |
| Cond Pump Recirculate Timer<br>(Water-cooled = Yes)       | 30       | 15 to 90 seconds   | M  |
| Cond Pump<br>(Water-cooled=Yes & Ref=R410A or R134a)      | #1 Only  | #1 Only, #2 Only, Auto, #1 Prim, #2 Prim   | M  |
| Low Ambient Lockout(Water-Cooled = No)                    | 35.0 °F  | 35 to 70 °F<br>If Speedtrol = Yes<br>-2.0 to 70.0°F (R407C)<br>-10.0 to 70.0 (R410A)<br>N/A (R134a)  | M  |
| Demand Limit  | Off      | Off, On  | M  |
| * Water Cooled  | Off      | Off, On  | M  |
| Ice Time Delay  | 12 hrs   | 1 to 23 hrs  | M  |
| Clear Ice Delay   | No       | No, Yes  | M  |
| Hot Gas Delay Time  | 30 sec.  | 30 to 180 seconds  | M  |
| BAS Protocol  | Modbus   | BACnet, LonWorks, Modbus   | M  |
| Ident number  | 001      | 000-200  | M  |
| Baud rate   | 9600     | 1200,2400,4800,9600,19200  | M  |
| Units   | F/psi    | F/psi (only)   |    |
| Language  | English  | English (only)   |    |
| * Refrigerant Select                                      | None     | R407C, R410A, R134a  |    |
| Cooling Reset Type  | None     | None, 4-20mA, [Return( Refrig = R134a only)]   | O  |
| Cooling Maximum Reset                                     | 10 °F    | 0 to 16 °F   | O  |
| Cooling Start Reset Delta T                               | 10 °F    | 0 to 16 °F (Refrig = R134a only)   | O  |
| <b>Compressor</b>   |          |  |    |
| # of Compressors<br>(Refrig = R410A or R134a to select 6) | 4        | 4, 6   | M  |
| Clear Cycle Tmr   | Off      | On/Off   | M  |
| Stage Up Delay  | 240 sec  | 90 to 480 seconds  | M  |
| Stage Down Delay  | 30       | 20 to 60 sec   | M  |
| Start-Start   | 15 min   | 10 to 60 min   | M  |
| Stop-Start  | 5 min    | 3 to 20 min  | M  |

**Table 7, Continued**

| Description  | Default  | Range  | PW |
|--|--|--|----|
| Expansion Valve Type                               | Electronic                                       | Thermal, Electronic  | M  |
| Circuit 1 EXV Control                              | Auto   | Auto, Manual   | M  |
| Circuit 1 EXV Position                             | N/A  | 0-100%   | M  |
| Circuit 2 EXV Control                              | Auto   | Auto, Manual   | M  |
| Circuit 2 EXV Position                             | N/A  | 0-100%   | M  |
| MaxOpPress   | 156  | 142 – 170 psig   | M  |
| SuperheatTarg                                      | 10   | 8-12°F   | M  |
| <b>Alarms</b>                                      |  |  |    |
| Low Evap Pressure-Hold                             | See following section; Automatic Adjusted Limits |  | M  |
| Low Evap Pressure-Unload                           |  |  | M  |
| High Cond Pressure – Unload                        | Water: 405 psig<br>Air: 550 psig                 | Water: 355 – 425 psig<br>Air: 410- - 555 psig                                    | M  |
| High Cond Pressure – Stop                          | Water: 420 psig<br>Air: 565 psig                 | Water: 375 – 435 psig<br>Air: 425 – 570 psig                                     | M  |
| Evap. Freeze                                       | 38.0 °F  | 37.0 to 42.0 °F<br>Glycol: 17.5 to 42.0°F (R134a,R407C)<br>7.5 to 42.0°F (R410A) | M  |
| Cond. Freeze                                       | 34.0 °F  | 18 to 42 °F  | M  |
| High Condenser Pressure Stop<br>(Water-Cooled = Y) | 280 psi<br>420 psi                               | 260 to 380 psi (R407C) 375<br>TO 435 psi (R410A)                                 | M  |
| High Condenser Pressure Stop<br>(Water Cooled = N) | 380 psi<br>565 psi                               | 260 to 380 psi (R407C) 425<br>to 570 psi (R410A)                                 | M  |
| High Condenser Pressure Stop (R134a)               | 185 psi  | 170 to 425 psi   | M  |
| Evap Flow Proof                                    | 5 sec.   | 5 to 15 seconds  | M  |
| Cond Flow Proof                                    | 5 sec.   | 5 to 15 seconds  | M  |
| Recirc Timeout                                     | 3 min.   | 1 to 10 minutes  | M  |
| * Phase Voltage Protection                         | N  | N,Y  | M  |
| * Ground Fault Protection                          | N  | N,Y  | M  |
| Low OAT Start Time                                 | 60 sec.  | 30 to 240 seconds  | M  |
| <b>Condenser Fans (Water Cooled = N)</b>           |  |  |    |
| Number of fans                                     | 4  | 4 to 8 (10 for R410a)  | M  |
| Speedtrol Option                                   | No   | No,Yes   | M  |
| Stg on Deadband Stg 2                              | 15 °F  | 15 to 25°F   | M  |
| Stg on Deadband Stg 3                              | 10°F   | 10 to 15°F   | M  |
| Stg on Deadband Stg 4                              | 10°F   | 10 to 15°F   | M  |
| Stg Off Deadband Stg 1                             | 20°F   | 15 to 20°F   | M  |
| Stg Off Deadband Stg 2                             | 15°F   | 10 to 15°F   | M  |
| Stg Off Deadband Stg 3                             | 10°F   | 6 to 10°F  | M  |
| Stg Off Deadband Stg 4                             | 10°F   | 6 to 10°F  | M  |
| Cond Sat Temp Target                               | 100°F  | 80 to 120°F  | M  |
| Forced Fan 1 (>75°F)                               |  |  |    |
| Forced Fan 2 (>90°F)                               |  |  |    |
| Forced Fan 3 (>105°F)                              |  |  |    |
| <b>Cooling Tower (Water Cooled = Y)</b>            |  |  |    |
| Tower Control                                      | None   | None, Temperature  | M  |
| Tower Stages                                       | 2  | 0 to 2   | M  |
| Stage Up Time                                      | 2 min  | 1 to 60 min  | M  |
| Stage Down Time                                    | 5 min  | 1 to 60 min  | M  |
| Stage Differential                                 | 3.0 °F   | 1.0 to 10.0 °F   | M  |
| Stage #1 On  | 70 °F  | 40 to 120 °F   | M  |
| Stage #2 On  | 75 °F  | 40 to 120 °F   | M  |
| Valve/VFD Control                                  | None   | None, Valve Set point, Valve Stage, VFD<br>Stage, Valve SP/VFD Stage             | M  |
| Valve Setpoint                                     | 65 °F  | 60 to 120 °F   | M  |
| Valve Deadband                                     | 2.0 °F   | 1.0 to 10.0 °F   | M  |
| Stage Fan Down @                                   | 20%  | 0 to 100%  | M  |
| Stage Fan Up @                                     | 80%  | 0 to 100%  | M  |
| Valve Control Range (Min)                          | 10%  | 0 to 100%  | M  |
| Valve Control Range(Max)                           | 90%  | 0 to 100%  | M  |
| Valve Type   | NC to tower                                      | NC, NO   | M  |
| Minimum Start Position                             | 0%   | 0 to 100%  | M  |
| Minimum Position @                                 | 60 °F  | 0 to 100 °F  | M  |
| Maximum Start Position                             | 100%   | 0 to 100%  | M  |
| Maximum Position @                                 | 90 °F  | 0 to 100 °F  | M  |
| Error Gain   | 25   | 10 to 99   | M  |
| Slope Gain   | 25   | 10 to 99   | M  |

## Automatic Adjusted Limits

The following are set points that will be limited based on the option selected.

### Evaporator Leaving Water Temperature

| Mode                      | Refrigerant Type | Range      |
|---------------------------|------------------|------------|
| Unit Mode = Cool          | R134a, R410A     | 40 to 60°F |
| Unit Mode = Cool w/Glycol | R134a            | 20 to 60°F |
| Unit Mode = Cool w/Glycol | R410a            | 15 to 60°F |
| Unit Mode = Ice           | R410A            | 20 to 40°F |

### Condenser Leaving Water Temperature

| Mode            | Refrigerant Type | Range        |
|-----------------|------------------|--------------|
| Unit Mode= HEAT | R134a            | 110 to 160°F |

### Evaporator Freeze Temperature

| Mode                                    | Refrigerant Type | Range        |
|---|------------------|--------------|
| Unit Mode = Cool                        | R134a, R410A     | 36 to 42°F   |
| Unit Mode = Cool w/Glycol, Ice w/Glycol | R134a            | 18 to 42°F   |
| Unit Mode = Cool w/Glycol, Ice w/Glycol | R410A            | 12.5 to 42°F |

### Ice Leaving Water Temperature

| Refrigerant Type | Range      |
|------------------|------------|
| R134a            | N/A        |
| R407C            | 20 to 40°F |
| R410A            | 15 to 40°F |

### Low Evaporator Pressure Inhibit Loading and Unloading

| Mode                                    | Refrigerant Type | Range         |
|---|------------------|---------------|
| Unit Mode = Cool                        | R134a            | 26 to 54 psi  |
|   | R410A            | 97 to 115 psi |
| Unit Mode = Cool w/Glycol, Ice w/Glycol | R134a            | 12 to 54 psi  |
|   | R410A            | 48 to 115 psi |

### Low Ambient Lockout Temperature

| Speedtrol     | Range     |
|---------------|-----------|
| Speedtrol = N | 35 – 70°F |
| Speedtrol = Y | -2 – 70°F |

**NOTE:** The backup mechanical high pressure cutout is set at 450 psi for water cooled applications and 600 psi for air cooled for air-cooled applications.

## Dynamic Defaults

Some set points will have a particular default value loaded when another setting is changed.

### Refrigerant Dependent Defaults

| Set Point                      | Refrigerant Type |                          |
|--------------------------------|------------------|--------------------------|
|                                | R134a            | R410A                    |
| Low Evaporator Pressure Hold   | 29 psi           | 101 psi                  |
| Low Evaporator Pressure Unload | 28 psi           | 100 psi                  |
| High Condenser Pressure Unload | 170 psi          | 550 psi AC<br>405 psi WC |
| High Condenser Pressure        | 185 psi          | 565 psi AC<br>420 psi WC |

AC = Air Cooled, WC = Water Cooled (R134a is water cooled ONLY)

### Number of Fans Dependent Defaults

When the number of fans setting is changed, the forced fan set points will default to values as shown in the following table:

| Set Point             | Number of Fans Set Point |   |   |    |
|-----------------------|--------------------------|---|---|----|
|                       | 4                        | 6 | 8 | 10 |
| Forced Fan 1 (>75°F)  | 1                        | 1 | 1 | 1  |
| Forced Fan 2 (>90°F)  | 1                        | 1 | 2 | 2  |
| Forced Fan 3 (>105°F) | 2                        | 2 | 3 | 3  |

## Events & Alarms

---

Situations may arise that require some action from the chiller or that should be logged for future reference. Conditions that cause a shutdown and require manual reset is known as a stop alarm. Other conditions can trigger what is known as an event, which may or may not require action in response. All stop alarms and events are logged.

### Unit Stop Alarms

The alarm output and red button is turned ON when any stop alarm occurs and turned off when all alarms have been cleared.

### Evaporator Flow Loss

**Alarm description (as shown on screen):** Evaporator Flow Loss

**Trigger:**

- 1: Evaporator Pump State = Run AND Evaporator Flow Digital Input = No Flow for time > Evap Flow Proof Set Point AND at least one compressor running.
- 2: Evaporator Pump State = Start for time greater than Recirc Timeout Set Point AND all pumps have been tried AND Evaporator Flow Digital Input = No Flow.

**Action Taken:** Rapid stop all circuits.

**Reset:**

This alarm can be cleared at any time manually via the keypad or via the BAS clear alarm signal.

If active via trigger condition 1:



When the alarm occurs due to this trigger, it can auto reset the first two times each day, with the third occurrence being manual reset.

For the auto-reset occurrences, the alarm will reset automatically when the evaporator state is Run again. This means the alarm stays active while the unit waits for flow, then it goes through the recirculation process after flow is detected. Once the recirculation is complete, the evaporator goes to the Run state which will clear the alarm. After three occurrences, the count of occurrences is reset and the cycle starts over if the manual reset flow loss alarm is cleared.

If active via trigger condition 2:

If the flow loss alarm has occurred due to this trigger, it is always a manual reset alarm.

## Condenser Flow Loss (Note: WaterCooled = On & TGZ units Only)

**Alarm description (as shown on screen):** Condenser Flow Loss

**Trigger:**

- 1: Condenser Pump State = Run AND Condenser Flow Digital Input = No Flow for time > Cond Flow Proof Set Point AND at least one compressor running.
- 2: Condenser Pump State = Start for time greater than Recirc Timeout Set Point AND all pumps have been tried AND Condenser Flow Digital Input = No Flow.

**Action Taken:** Rapid stop all circuits.

**Reset:**

This alarm can be cleared at anytime manually via the keypad or via the BAS clear alarm signal.

If active via trigger condition 1:

When the alarm occurs due to this trigger, it can auto reset the first two times each day, with the third occurrence being manual reset.

For the auto-reset occurrences, the alarm will reset automatically when the condenser pump state is Run again. This means the alarm stays active while the unit waits for flow, then it goes through the recirculation process after flow is detected. Once the recirculation is complete, the condenser pump goes to the Run state which will clear the alarm. After three occurrences, the count of occurrences is reset and the cycle starts over if the manual reset flow loss alarm is cleared.

If active via trigger condition 2:

If the flow loss alarm has occurred due to this trigger, it is always a manual reset alarm.

## Low Evaporator Pressure

**Alarm description (as shown on screen):** Evap Press Low Cir N

**Trigger:** [Circuit State = Run AND Freezestat trip AND Low OAT Start not active]  
OR Evaporator Press < Absolute Low Pressure Limit AND Circuit State = Run

The absolute low pressure limit is 5 psi with R134a and R407C refrigerants and 20 psi with R410A refrigerant.

Freezestat logic allows the circuit to run for varying times at low pressures. The lower the pressure, the shorter the time the compressor can run. This time is calculated as follows:

*Freeze error* = Low Evaporator Pressure Unload – Evaporator Pressure

*Freeze time* =

[60 – 2.7 x freeze error] with R134a refrigerant, limited to a range of 20-60 seconds

[60 – 1.6 x freeze error] with R407C refrigerant, limited to a range of 20-60 seconds [60 –

freeze error] with R410A refrigerant, limited to a range of 20-60 seconds

When the evaporator pressure goes below the Low Evaporator Pressure Unload set point, a timer starts. If this timer exceeds the freeze time, then a 'Evap Press Low Cir N' alarm trip occurs. If the evaporator pressure rises to the unload set point or higher, and the freeze time has not been exceeded, the timer will reset.

**Action Taken:** Rapid stop circuit

**Reset:** This alarm can be cleared manually via the keypad if the evaporator pressure is above the absolute low-pressure limit.

### High Condenser Pressure

**Alarm description (as shown on screen):** Cond Press High Cir N

**Trigger:** Condenser Pressure > High Condenser Pressure Set Point

**Action Taken:** Rapid stop circuit

**Reset:** This alarm can be cleared manually via the keypad.

### Mechanical High Pressure/Motor Protect

**Alarm description (as shown on screen):** MHP or Motor Prot N

**Trigger:** MHP/MP input is low and over 150 seconds lapsed since controller boot-up

**Action Taken:** Rapid stop circuit

**Reset:** This alarm can be cleared manually via the keypad if the MHP/MP input is high.

### Phase Voltage Protection

**Alarm description (as shown on screen):** Phase/Voltage Cir N

**Trigger:** PVM input is low and Phase Voltage set point = enable.

**Action Taken:** Rapid stop circuit

**Reset:** Auto reset when PVM input is high

### Ground Fault Protection

**Alarm description (as shown on screen):** Ground Fault Cir N

**Trigger:** GFP input is low and Ground Fault set point = enable.

**Action Taken:** Rapid stop circuit

**Reset:** This alarm can be cleared manually via the keypad.

### Low OAT Restart Fault

**Alarm description (as shown on screen):** Low OAT Start Fail N

**Trigger:** Circuit has failed three low OAT start attempts

**Action Taken:** Rapid stop circuit

**Reset:** This alarm can be cleared manually via the keypad.

### Evaporator Water Freeze Protect

**Alarm description (as shown on screen):** Evap Water Freeze

**Trigger:** Evaporator LWT drops below evaporator freeze protect set point AND Unit State = Auto

**Action Taken:** Rapid stop all circuits

**Reset:** This alarm can be cleared manually via the keypad or via the BAS clear alarm signal, but only if the alarm trigger conditions no longer exist.

### Leaving Evaporator Water Temperature Sensor Fault

**Alarm description (as shown on screen):** Evap LWT Sens Fault

**Trigger:** Sensor shorted or open

**Action Taken:** Normal stop all circuits

**Reset:** This alarm can be cleared manually via the keypad, but only if the sensor is back in range.

### Leaving Condenser Water Temperature Sensor Fault

**Alarm description (as shown on screen):** CondLWT Sens Fault

**Trigger:** Sensor shorted or open AND TGZ unit (refrig = R134a) AND operating in 'heat' mode.

**Action Taken:** Normal stop all circuits

**Reset:** This alarm can be cleared manually via the keypad, but only if the sensor is back in range.

### **Suction Temperature Sensor Fault**

**Alarm description (as shown on screen):** SuctT Sensor Fail N

**Trigger:** Sensor shorted or open AND Expansion Valve Type = Electronic

**Action Taken:** Rapid stop circuit

**Reset:** This alarm can be cleared manually via the keypad, but only if the sensor is back in range.

### **Evaporator Pressure Sensor Fault**

**Alarm description (as shown on screen):** EvapP Sensor Fail N

**Trigger:** Sensor shorted or open. If failing high (open), logic has been added that requires the Leaving Evaporator Temperature to be below 75°F. This will prevent nuisance trips due to conditions where the evaporator water temperature is high which could cause false alarms.

**Action Taken:** Rapid stop circuit

**Reset:** This alarm can be cleared manually via the keypad, but only if the sensor is back in range.

### **Condenser Pressure Sensor Fault**

**Alarm description (as shown on screen):** CondP Sensor Fail N

**Trigger:** Sensor shorted or open

**Action Taken:** Rapid stop circuit

**Reset:** This alarm can be cleared manually via the keypad, but only if the sensor is back in range.

### **Condenser Entering or Outdoor Air Temperature Sensor Fault**

**Alarm description (as shown on screen):** OAT Sensor Fault

**Trigger:** Sensor shorted or open

**Action Taken:** Normal stop all circuits

**Reset:** This alarm can be cleared manually via the keypad, but only if the sensor is back in range

### **Evaporator Water Freeze Protect**

**Alarm description (as shown on screen):** Evap Water Freeze

**Trigger:** Evaporator LWT drops below evaporator freeze protect set point AND Unit State = Auto

**Action Taken:** Rapid stop all circuits

**Reset:** This alarm can be cleared manually via the keypad or via the BAS clear alarm signal, but only if the alarm trigger conditions no longer exist.

### **No Pressure Change at Start**

**Alarm description (as shown on screen):** NoPressChgAtStartN

**Trigger:** Circuit has failed twice on a No Pressure Change at Start Condition. A No Pressure Change at Start Condition indicates that after the start of the first compressor on the circuit, at least a 1 psi drop in evaporator pressure OR a 1 psi increase in condenser pressure has not occurred after 15 seconds of compressor operation.

**Action Taken:** Rapid stop circuit

**Reset:** This alarm can be cleared manually via the keypad.

### **EXB Comm Failure on CP1**

**Alarm description (as shown on screen):** No EXB comm CP1

**Trigger:** CP1 does not have communication with either EXB1 for 60 seconds after power up. This alarm will only occur if 10 Fan, evaporator pump #2, or condenser pump #2 operation is selected. After communication is established, when communication is lost to either EXB an immediate shutdown occurs.

**Action Taken:** Rapid stop all circuits

**Reset:** Auto clear when EXB1 is communicating with CP1.

## Alarm Log

An alarm log stores the last 25 alarms and/or events to occur. When an alarm or event occurs, it is put into the first slot in the alarm log and all others are moved down one, dropping the last entry. In the alarm log, the date and time the alarm occurred are stored, as well as a list of other parameters. These parameters include compressor states, evaporator pressure, condenser pressure, number of fans on, OAT, and evaporator LWT.

## Active Alarms

When an alarm occurs, it appears in the active alarm list. The active alarm list holds a record of all active alarms, which includes the date and time each occurred.

## Clearing Alarms

A password is NOT required to clear an active alarm. Active alarms must be cleared at the unit controller. To clear active alarms scroll down to the end of the Active Alarm list press Enter to clear all active alarms. If the user attempts to clear an alarm while the alarm condition still exists, a new alarm will be generated immediately.

## Limit Events

The following events do not cause a rapid stop but limit operation of the chiller in some way as described in the Action Taken. All limit events do NOT appear in the Active Alarm window and are NOT logged in the Alarm Log

### Low Evaporator Pressure - Hold

**Event description (as shown on screen):** Evap Press Low HoldN

**Trigger:**

This event is triggered if all of the following are true:

- circuit state = Run
- circuit is not currently in a low OAT start
- has been at least 30 seconds since a compressor has started on the circuit.
- evaporator pressure  $\leq$  Low Evaporator Pressure - Hold set point

**Action Taken:** Inhibit staging on of additional compressors on the circuit.

**Reset:** While still running, the event will be reset if evaporator pressure  $>$  (Low Evaporator Pressure - Hold set point + 8psi for R134a/R407C or 13 psi for R410A). The event is also reset if the circuit state is no longer run.

### Low Evaporator Pressure - Unload

**Event description (as shown on screen):** EvapPressLow Unload N

**Trigger:**

This event is triggered if all of the following are true:

- circuit state = Run
- more than one compressor is running on the circuit
- circuit is not currently in a low OAT start
- has been at least 30 seconds since a compressor has started on the circuit.
- evaporator pressure  $\leq$  Low Evaporator Pressure - Unload set point for a time greater than half of the current freezestat time

**Action Taken:** Stage off one compressor on the circuit every 10 seconds, except the last one.

**Reset:** While still running, the event will be reset if evaporator pressure  $>$  (Low Evaporator Pressure - Hold set point + 8psi for R134a/R407C or 13 psi for R410A). The event is also reset if the circuit state is no longer run.

## High Condenser Pressure - Unload

**Event description (as shown on screen):** CondPressHighUnloadN

**Trigger:**

This event is triggered if all of the following are true:

- circuit state = Run
- more than one compressor is running on the circuit
- condenser pressure > High Condenser Pressure – Unload set point

**Action Taken:** Stage off one compressor on the circuit every 10 seconds, except the last one.

**Reset:** While still running, the event will be reset if condenser pressure drops below the “Hold Clear @” value which is displayed on that circuit’s VIEW CIRCUIT n (1) screen. The “Hold Clear @” is calculated based on number of compressors, refrigerant, and number of High Condenser Pressure – Unload occurrences since the circuit has cycled off or since midnight. See table below:

| Condenser Configuration | Compressors | R410A   | R134a  | Step Increase |
|-------------------------|-------------|---------|--------|---------------|
| Water-Cooled            | 4           | 40 psi  | 30 psi | 10 psi        |
|                         | 6           | 30 psi  | 20 psi | 10 psi        |
| Air-Cooled              | 4           | 100 psi | N/A    | 15 psi        |
|                         | 6           | 80 psi  | N/A    | 15psi         |

## Failed Pumpdown

**Event description (as shown on screen):** Pumpdown Fail Cir N

**Trigger:** Circuit state = pumpdown for time > 60 seconds

**Action Taken:** Shutdown circuit

**Reset:** N/A

## Condenser Freeze Event

**Event description (as shown on screen):** Cond Freeze Circ N

**Trigger:** Cond Sat Refr Temperatre < Condenser Freeze Set Point AND Condenser Pump State = OFF

**Action Taken:** Start condense pump.

**Reset:** N/A

## Condenser Freeze Event (Water Cooled = Y Only)

**Event description (as shown on screen):** Cond Freeze Circ N

**Trigger:** Cond Sat Refr Temp < Condenser Freeze Set Point AND Condenser Pump State = OFF

**Action Taken:** Start condenser pump.

**Reset:** Cond Sat Refr Temp > Condenser Freeze Set Point plus 2°F.

## Suction Temperature Sensor Fail

**Event description (as shown on screen):** SuctT Sensor Fail N

**Trigger:** Sensor shorted or open.

**Action Taken:** None.

**Reset:** N/A

## Entering Evaporator Water Temperature Sensor Fail (TGZ unit only)

**Event description (as shown on screen):** Evap EWT Sensor Fail

**Trigger:** Sensor shorted or open.

**Action Taken:** None.

**Reset:** N/A

### **Liquid Line Temperature Sensor Fail (TGZ unit only)**

**Event description (as shown on screen):** Low Source Temp

**Trigger:** Sensor shorted or open.

**Action Taken:** None.

**Reset:** N/A

### **Low Source Water Temperature (TGZ unit in 'heat' mode only)**

**Event description (as shown on screen):** LiqL Sensor Fail N

**Trigger:** Unit is in heat mode and the leaving evaporator water temperature drops below the Low Source Temperature set point.

**Action Taken:** Stage off one compressor immediately and the remaining being staged off based upon the "InterStage Dn" set point time interval.

**Reset:** N/A

### **EXB Comm Failure on CP1 (TGZ unit only)**

**Event description (as shown on screen):** No EXB comm CP1

**Trigger:** CP1 does not have communication with either EXB1 for 60 seconds after power up. This event is only active when the expansion board is not intended to operate evaporator or condenser pump #2.

**Action Taken:** None.

**Reset:** N/A.

### **Event Log**

An Event Log similar to the Alarm Log stores the last 25 Event occurrences. There must be an active password for access to the Event Log. To navigate to the Event log press the Left Arrow key from any Alarm Log screen. When an event occurs, it is recorded in the first slot in the Event Log. All other entries are moved down in the Event Log and the last entry is dropped if 25 earlier event occurrences have been logged. Each Event Log entry includes an event description and a time and date stamp for the event occurrence.

# Controller Operation

---

## Calculations

The Control Band defines the temperatures around the Controlling Leaving Water Temperature set point where compressors will be staged on or off. In cool mode, the controlling leaving water temperature set point will be Evap LWT. In heat mode, the controlling leaving water temperature set point will be Heat LWT.

**In cooling mode**, the Control Band is calculated as follows:

*Control Band = Evap Delta Temperature Set Point \* 0.3 Four compressor units*

*Control Band = Evap Delta Temperature Set Point \* 0.2 Six compressor units*

**In heating mode**, the Control Band is calculated as follows:

*Control Band = Cond Delta Temperature Set Point \* 0.3 Four compressor units*

*Control Band = Cond Delta Temperature Set Point \* 0.2 Six compressor units*

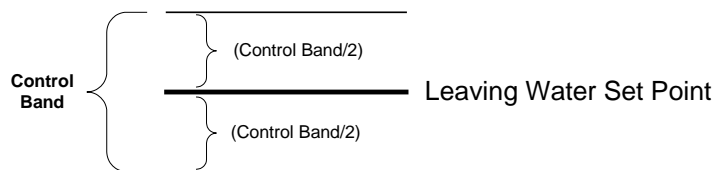

### If the Unit mode is Cool:

When the Cool Leaving Water Temperature set point is more than half the Control Band above 39.0° F the Stage Up temperature is calculated as follows:

$$\text{Stage Up Temperature} = \text{Cool LWT} + (\text{Control Band}/2)$$

The Stage Down temperature is calculated as:

$$\text{Stage Down Temperature} = \text{Cool LWT} - (\text{Control Band}/2)$$

If the Cool Leaving Water Temperature set point is less than half the Control Band above 39.0° F the Stage Down temperature is calculated as:

$$\text{Stage Down Temperature} = \text{Cool LWT} - (\text{Cool LWT} - 39.0^\circ\text{F})$$

Stage Up temperature is calculated as:

$$\text{Stage Up temperature} = \text{Cool LWT} + \text{Control Band} - (\text{Cool LWT} - 39.0^\circ\text{F})$$

In all other Unit modes the compressor staging temperatures are calculated as shown below:

$$\text{Stage Up Temperature} = \text{Cool LWT} + (\text{Control Band}/2)$$

$$\text{Stage Down Temperature} = \text{Cool LWT} - (\text{Control Band}/2)$$

The Cool Start up and Shutdown temperatures are calculated from the Control Band. The Start Up temperature determines when the first compressor on the unit will start. The Start Up temperature calculation is shown below:

$$\text{Start Up Temperature} = \text{Stage Up Temperature} + \text{Start Up Delta Temperature}$$

The Shutdown temperature defines when the last running compressor will shutdown. The Shutdown temperature calculation is:

$$\text{Shutdown Temperature} = \text{Stage Down Temperature} - \text{Shutdown Delta Temperature}$$

### If the Unit mode is Heat:

Stage Up temperature is calculated as follows:

$$\text{Stage Up Temperature} = \text{Heat LWT} - (\text{Control Band}/2)$$

The Stage Down temperature is calculated as:

$$\text{Stage Down Temperature} = \text{Heat LWT} + (\text{Control Band}/2)$$

The Heat Start up and Shutdown temperatures are calculated from the Control Band. The Start Up temperature determines when the first compressor on the unit will start. The Start Up temperature calculation is shown below:

$$\text{Start Up Temperature} = \text{Stage Up Temperature} - \text{Start Up Delta Temperature}$$

The Shutdown temperature defines when the last running compressor will shutdown. The Shutdown temperature calculation is:

$$\text{Shutdown Temperature} = \text{Stage Down Temperature} + \text{Shutdown Delta Temperature}$$

## Leaving Water Temperature (LWT) Reset

The active leaving water set point is set to the current Leaving Water Temperature (LWT) set point unless the unit is in either cool or heat mode and any of the reset methods below are selected. The type of reset in effect is determined by the LWT Reset Type set point.

### Reset Type = NONE

The Active Leaving Water Temperature set point is set equal to the current LWT set point. IN cool mode, this will be Evap LWT and in heat mode this will be Heat LWT.

### Reset Type = 4-20 mA

The Active Leaving Water set point is adjusted by the 4 to 20 mA reset analog input.

#### Cooling Mode

The Active Leaving Water set point is adjusted by the 4 to 20 mA reset analog input.

Parameters used:

1. Evaporator Leaving Water Temperature set point (Evap LWT)
2. Cooling Maximum Reset set point (Clg MaxRes)
3. LWT Reset signal 4-20mA

Reset is 0°F and the active leaving water set point is equal to the Evap LWT set point if the reset signal is less than or equal to 4 mA. Reset is equal to the Max Reset set point and the active leaving water set point is equal to the Evap LWT plus Max Reset set points if the reset signal equals or exceeds 20 mA. The amount of reset will vary linearly between these extremes if the reset signal is between 4 mA and 20 mA. An example of the operation of 4-20 reset in Cool mode is shown below.

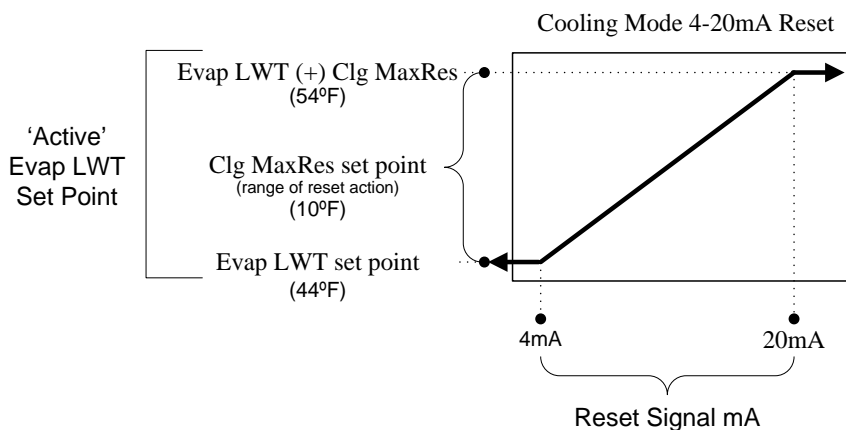

#### Heating Mode (only for TGZ unit Refrig = R134a)

The Active Leaving Water set point is adjusted by the 4 to 20 mA reset analog input.



Parameters used:

1. Heating Leaving Water Temperature set point (Heat LWT)
2. Heating Maximum Reset set point (Htg MaxRes)
3. LWT Reset signal 4-20mA

Reset is 0°F and the active leaving water set point is equal to the Heat LWT set point if the reset signal is less than or equal to 4 mA. Reset is equal to the Max Reset set point and the active leaving water set point is equal to the Heat LWT minus Max Reset set points if the reset signal equals or exceeds 20 mA. The amount of reset will vary linearly between these extremes if the reset signal is between 4 mA and 20 mA. An example of the operation of 4-20 mA reset in Heat mode is shown below.

## Reset Type = Return (only for TGZ unit, Refrig = R134a)

### Cooling Mode

The Active Cooling Leaving Water set point is adjusted based upon the difference between the chiller's entering and leaving evaporator water temperatures.

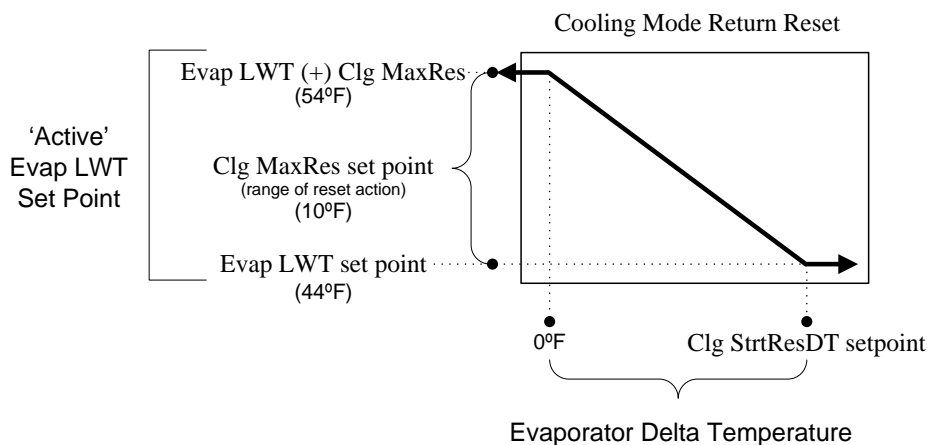

The active cooling leaving water set point is reset using the following parameters:

1. Evaporator Leaving Water Temperature set point (Evap LWT)
2. Cooling Maximum Reset set point (Clg MaxRes)
3. Cooling Start Reset Delta Temperature (Clg StrtResDT)
4. Evaporator Delta Temperature (evaporator entering water temperature minus leaving temperature)

Reset is accomplished by changing the Active Cooling Leaving Water set point from the Evap LWT set point to the sum of Evap LWT (+) Cooling Maximum Reset set points as the evaporator delta temperature (entering minus leaving) varies from the Cooling Start Reset Delta T set point towards 0° F delta temperatures.

### Heating Mode

The Active Heating Leaving Water set point is adjusted based upon the difference between the chiller's entering and leaving condenser water temperatures.

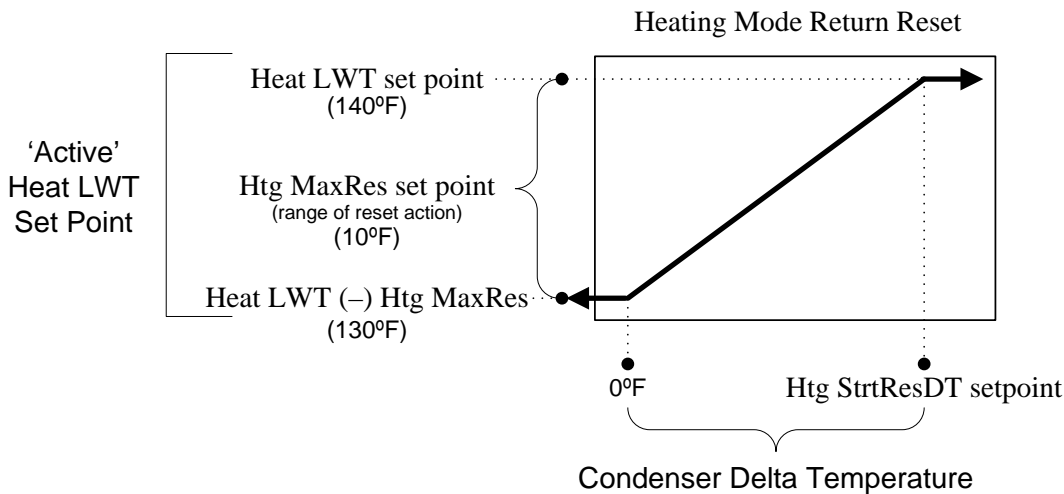

The active heating leaving water set point is reset using the following parameters:

1. Heating Leaving Water Temperature set point (Heat LWT)
2. Heating Maximum Reset set point (Htg MaxRes)
3. Heating Start Reset Delta Temperature (Htg StrtResDT)
4. Condenser Delta Temperature (condenser leaving water temperature minus entering temperature)

Reset is accomplished by changing the Active Heating Leaving Water set point from the Heat LWT set point to the value of [Heat LWT (-) Heating Maximum Reset set points] as the condenser delta temperature (leaving minus entering) varies from the Heating Start Reset Delta T set point towards 0°F delta temperature.

## Active LWT Set Point

The active LWT set point represents the current control set point based on unit mode and reset. If unit mode is ice, then the active set point is equal to the ice set point. If the unit mode is cool, the active set point is the cool set point plus the leaving water reset value. If the unit mode is heat, the active set point is the heat set point minus the leaving water reset value.

## LWT Error

LWT error compares the actual LWT to the active LWT set point.

The equation for cool mode is:

$$LWT\ error = LWT - active\ LWT\ set\ point$$

The equation for heat mode is:

$$LWT\ error = active\ LWT\ set\ point - LWT$$

## LWT Slope

LWT slope is calculated such that the slope represents a time frame of one minute.

Every 12 seconds, the current LWT is subtracted from the value 12 seconds back. This value is added to a buffer containing values calculated at the last five intervals. The final result is a slope value that is an average over the past 60 seconds.

## Pull Down Rate

The slope value calculated above will be a negative value as the water temperature is dropping. For use in some control functions, the negative slope is converted to a positive value by multiplying by -1.

## Evaporator Saturated Temperature

Evaporator saturated temperature is calculated from the evaporator pressure for each circuit.

### R410a Evaporator Saturated Temperatures

When R410a refrigerant is selected the refrigerant pressure will be fitted to a curve made up of 24 straight-line segments. The accuracy of calculated saturated temperatures are less than +/- 0.5°F when compared to standard look up tables for R410a.

### R134a Evaporator Saturated Temperatures (Templifiers only)

When R134a refrigerant is selected the refrigerant pressure will be fitted to a curve made up of 12 straight-line segments. The accuracy of calculated saturated temperatures is +/- 0.5° F when compared to standard look up tables for R134a refrigerant.

## Condenser Saturated Temperature

Condenser saturated temperature shall be calculated from the condenser pressure for each circuit.

### R410a Evaporator Saturated Temperatures

When R410a refrigerant is selected the refrigerant pressure will be fitted to a curve made up of 24 straight-line segments. The accuracy of calculated saturated temperatures are less than +/- 0.5°F when compared to standard look up tables for R410a.

### R134a Evaporator Saturated Temperatures (Templifiers only)

When R134a refrigerant is selected the refrigerant pressure will be fitted to a curve made up of 12 straight-line segments. The accuracy of calculated saturated temperatures is +/- 0.5° F when compared to standard look up tables for R134a refrigerant.

## Evaporator Approach

The evaporator approach is calculated for each circuit.

For R134a and R410A refrigerant the equation is:

$$\text{Evaporator Approach} = \text{LWT} - \text{Evaporator Saturated Temperature}$$

For R407c refrigerant the equation is:

$$\text{Evaporator Approach} = \text{LWT} - \text{Evaporator Saturated Temperature} + 4.0^\circ \text{ F}$$

## Suction Superheat

Suction superheat is calculated for each circuit using the following equation:

$$\text{Suction superheat} = \text{Suction Temperature} - \text{Evaporator Saturated (Dew for R407c) Temperature}$$

## Pumpdown Pressure

The pressure to which a circuit will pump down is based on the Low Evaporator Pressure Unload set point. The equation is as follows:

$$\text{Pumpdown pressure} = \text{Low evap pressure unload} - 15 \text{ psi}$$

The low limit for the calculated Pumpdown Pressure set point is 10.0 psi

## Unit Enable

The Unit Enable Set Point controls enabling and disabling the unit. The Unit Enable Set Point has options of OFF and ON. The Unit OFF input, Remote input, keypad entry, and BAS request can alter this set point. The Control Source Set Point determines which sources can change the Unit Enable Set Point with options of SWITCHES, KEYPAD or NETWORK.

Changing the Unit Enable Set Point is accomplished according to the following table.

NOTE: An “x” indicates that the value is ignored.

| Unit Off Input | Control Source Set Point | Remote Input | Key-pad Entry | BAS Request | Unit Enable |
|----------------|--------------------------|--------------|---------------|-------------|-------------|
| OFF            | X                        | x            | x             | x           | OFF         |
| x              | SWITCHES                 | OFF          | x             | x           | OFF         |
| ON             | SWITCHES                 | ON           | x             | x           | ON          |
| ON             | KEYPAD                   | x            | OFF           | x           | OFF         |
| ON             | KEYPAD                   | x            | ON            | x           | ON          |
| ON             | NETWORK                  | x            | x             | OFF         | OFF         |
| ON             | NETWORK                  | OFF          | x             | x           | OFF         |
| ON             | NETWORK                  | ON           | x             | ON          | ON          |

## Unit Mode

The overall operating mode of the chiller is set by the Unit Mode Set Point with options of COOL, COOL w/Glycol, ICE w/Glycol, and TEST. This set point can be altered by the keypad, BAS, and Mode input. Changes to the Unit Mode Set Point are controlled by two additional set points.

- Available Modes Set Point: Determines the operational modes available at any time with options of COOL, COOL w/Glycol, COOL/ICE w/Glycol, ICE w/Glycol and TEST
- Control Source Set Point: Determines the source that can change the Unit Mode Set Point with options of KEYPAD, NETWORK, or SWITCHES.

When the Control source is set to KEYPAD, the Unit Mode shall stay at its previous setting until changed by the operator. When the Control source is set to BAS, the most recent BAS mode request shall go into effect even if it changed while the Control source was set to KEYPAD or DIGITAL INPUTS.

Changing the Unit Mode Set Point can be accomplished according to the following table.

NOTE: An “x” indicates that the value is ignored.

| Control Source Set Point | Mode Input | Keypad Entry  | BAS Request | Available Modes Set Point | Unit Mode     |
|--------------------------|------------|---------------|-------------|---------------------------|---------------|
| X                        | X          | x             | x           | COOL                      | COOL          |
| X                        | x          | x             | x           | COOL w/Glycol             | COOL w/Glycol |
| SWITCHES                 | OFF        | x             | x           | COOL/ICE w/Glycol         | COOL w/Glycol |
| SWITCHES                 | ON         | x             | x           | COOL/ICE w/Glycol         | ICE w/Glycol  |
| KEYPAD                   | x          | COOL w/Glycol | x           | COOL/ICE w/Glycol         | COOL w/Glycol |
| KEYPAD                   | x          | ICE w/Glycol  | x           | COOL/ICE w/Glycol         | ICE w/Glycol  |
| NETWORK                  | x          | x             | COOL        | COOL/ICE w/Glycol         | COOL w/Glycol |
| NETWORK                  | x          | x             | ICE         | COOL/ICE w/Glycol         | ICE w/Glycol  |
| X                        | x          | x             | x           | ICE w/Glycol              | ICE w/Glycol  |
| X                        | x          | x             | x           | TEST                      | TEST          |

## Unit Test Mode

The unit test mode allows manual testing of controller outputs. Entering this mode requires the following conditions:

- Unit Switch = OFF
- Manager password active.
- Available Unit Mode set point = TEST

A test menu can then be selected to allow activation of the outputs. It shall be possible to switch each digital output ON or OFF and set the analog outputs to any value.

## Circuit Available

A circuit is available if the circuit switch is in the on position and no circuit alarms are active. Timers that delay startup or staging of a circuit do not render it unavailable.

## Power Up Start Delay

After powering up the unit, the motor protector modules may not reset for up to 150 seconds. After the control is powered up, no compressor can start for 150 seconds. Motor protect inputs are ignored during this time so as to avoid tripping a false alarm.

## Ice Mode Start Delay

An adjustable start to start ice delay timer will limit the frequency with which the chiller may start in Ice mode. The timer starts when the first compressor starts while the unit is in ice mode. While this timer is active, the chiller cannot restart in Ice mode. The time delay is user adjustable.

The ice delay timer may be manually cleared to force a restart in ice mode. A set point specifically for clearing the ice mode delay is available. In addition, cycling the power to the controller will clear the ice delay timer.

## Low Ambient Lockout

This feature is only available on air cooled units (WaterCooled=Off).

If the OAT drops below the low ambient lockout set point, then all running circuits will do a normal stop. Once the lockout has been triggered, no compressors will start until the OAT rises to the lockout set point plus 5°F.

## Unit State

The Unit will always be in one of three states. These states are Off, Auto, and Pumpdown. Transitions between these states are shown in the diagram on the following page.

**T1:** Off to Auto

Unit Enable = True AND

No Unit Alarm AND

IF Unit Mode = Cir 1 Available OR Cir 2 Available

**T2:** Auto to Pumpdown

Keypad Enable = Off OR

BAS Enable = Off OR

Remote Switch = Off OR

**T3:** Pumpdown to Off

Unit Alarm OR

Unit Switch Off OR

No Compressors Running

**T4:** Auto to Off

Unit Alarm OR

Unit Switch Off OR

No Compressors Running AND [Unit Mode = Ice AND Ice Delay Active] OR

No Compressors Running AND [No Circuit Available]

### Unit State Diagram

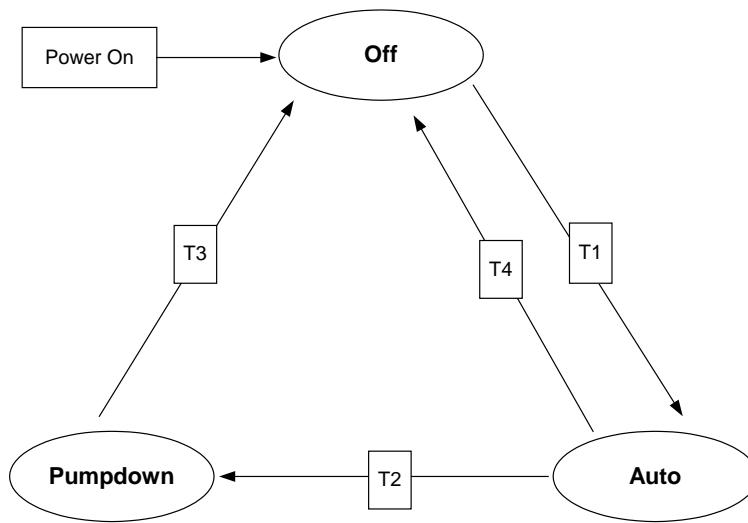

### Evaporator Water Pump State Control (Evap State)

The state-transition diagram shown below controls operation of the evaporator pump.

### Evaporator Pump State Diagram

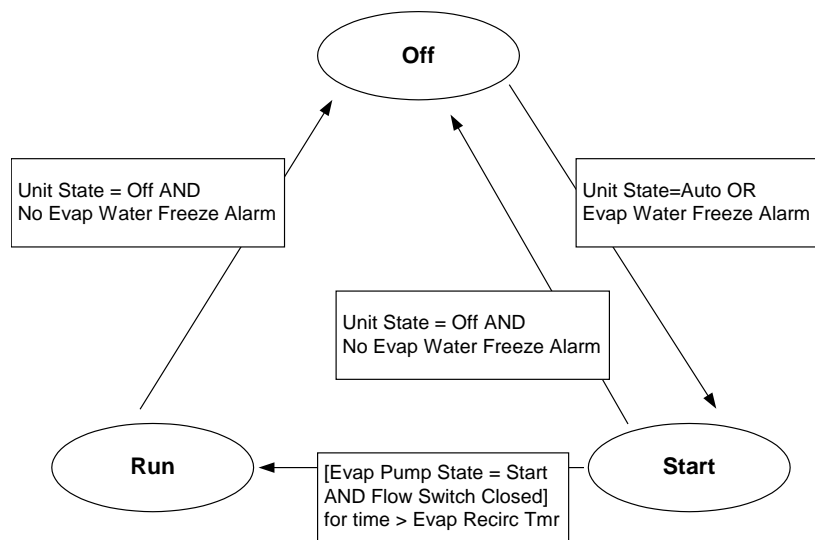

### Pump Selection

The pump output used will be determined by the Evap Pump Control set point. The setting allows the following configurations:

- #1 only – Pump 1 will always be used.
- #2 only – Pump 2 will always be used.
- Auto – The primary pump is the one with the least run hours, the other is used as a backup.
- #1 Primary – Pump 1 is used normally, with pump 2 as a backup.
- #2 Primary – Pump 2 is used normally, with pump 1 as a backup.

## Primary/Standby Pump Staging

The pump designated as primary will start first. If the evaporator state is start for a time greater than the recirculate timeout set point and there is no flow, then the primary pump will shut off and the standby pump will start. When the evaporator is in the run state, if flow is lost for more than half of the flow proof set point value, the primary pump will shut off and the standby pump will start. Once the standby pump is started, the flow loss alarm logic will apply if flow cannot be established in the evaporator start state, or if the flow is lost in the evaporator run state.

### Auto Control

If auto pump control is selected, the primary/standby logic above is till used. When the evaporator is not in the run state, the run hours of the pumps will be compared. The pump with the least hours will be designated as the primary at this time.

## Evaporator Water Flow Loss

The Evaporator Water Flow Loss logic allows the Unit to shutdown compressors on a loss of flow up to two times every twenty-four hours before locking the unit out on a Evaporator Flow Loss Alarm.

- If there are no compressors running when Evaporator Water Flow Loss is indicated the Unit Status changes to Auto:Wait for flow. The evaporator water pump state changes to Start and no alarms are indicated.
- If an Evaporator Water Flow Loss occurs while a compressor is running all of the running compressors will be shutdown. The alarm indicators are turned On and the Circuit Status for any circuit with running compressors becomes Off: Ready, the Unit Status becomes Auto: Wait For Flow and the evaporator water pump state changes to Start
- When flow is reestablished the Unit Status becomes Auto: Recirculate while the Evaporator Flow Recirculation Timer counts down. If there is continuous evaporator water flow while the Evaporator Recirculation Timer counts down the Alarm indicator is turned off, and the unit resumes normal start up procedures based on water temperature and cycle timers.
- If second Evaporator Water Flow Loss occurs within twenty-four hours the process described above is repeated.
- If a third loss of flow is indicated in a twenty-four hour time frame the unit will shut down on an Evaporator Water Flow Loss alarm and it will be locked out until this alarm is manually cleared.
- The twenty-four hour timer that limits the auto restart is reset when the control clock rolls over 00:00 each night.

## Condenser Fans – Air Cooled

Air-cooled condenser fan control is active only when the water cooled set point is set to off.

### Fantrol

Fans 1, 3, 5, 7, 9, 11 are for circuit #1, and fans 2, 4, 6, 8, 10, 12 are for circuit 2. Fans 1 and 2 start with the first compressor on the respective circuit when the ambient temperature is greater than 75°F. Below 75°F, these fans start when the condenser saturated temperature gets up to the condenser saturated temperature target. The compressor must be running in order to run any fans. R407C units are limited to 8 fans.

### Fan Stages

There are 2, 3, 4, 5 or 6 fans available per circuit. On 8, 10, and 12 fan units, fans 5/7, 6/8, 9/11 and 10/12 are controlled by one contactor for each pair, using virtual stages to allow a difference of only one fan between stages, See tables below:

#### 4 and 6-Fan Remote Condenser

| Stage | Fans Operating on Circuit 1 | Fans Operating on Circuit 2 |
|-------|-----------------------------|-----------------------------|
| 1     | Fan 1                       | Fan 2                       |
| 2     | Fans 1 & 3                  | Fans 2 & 4                  |
| 3     | Fans 1, 3, 5                | Fans 2, 4, 6                |

### 8-Fan Remote Condenser, R407C

| Stage | Fans Operating on Circuit 1 | Fans Operating on Circuit 2 |
|-------|-----------------------------|-----------------------------|
| 1     | Fan 1                       | Fan 2                       |
| 2     | Fans 1, 3                   | Fans 2, 4                   |
| 3     | Fans 1, 3, 5                | Fans 2, 6, 8                |
| 4     | Fans 1, 3, 5, 7             | Fans 2, 4, 6, 8             |

### 8-Fan Remote Condenser, R410A

| Stage | Fans Operating on Circuit 1 | Fans Operating on Circuit 2 |
|-------|-----------------------------|-----------------------------|
| 1     | Fan 1                       | Fan 2                       |
| 2     | Fans 1, 3                   | Fans 2, 4                   |
| 3     | Fans 1, 5, 7                | Fans 2, 6, 8                |
| 4     | Fans 1, 3, 5, 7             | Fans 2, 4, 6, 8             |

### 10 Fan Remote Condenser, R410A

| Stage | Fans Operating on Circuit 1 | Fans Operating on Circuit 2 |
|-------|-----------------------------|-----------------------------|
| 1     | Fan 1                       | Fan 2                       |
| 2     | Fans 1, 3                   | Fans 2, 4                   |
| 3     | Fans 1, 5, 7                | Fans 2, 6, 8                |
| 4     | Fans 1, 3, 5, 7             | Fans 2, 4, 6, 8             |
| 5     | Fans 1, 3, 5, 7, 9          | Fans 2, 4, 6, 8, 10         |

### 12Fan Remote Condenser, R410A

| Stage | Fans Operating on Circuit 1 | Fans Operating on Circuit 2 |
|-------|-----------------------------|-----------------------------|
| 1     | Fan 1                       | Fan 2                       |
| 2     | Fans 1, 3                   | Fans 2, 4                   |
| 3     | Fans 1, 5, 7                | Fans 2, 6, 8                |
| 4     | Fans 1, 3, 5, 7             | Fans 2, 4, 6, 8             |
| 5     | Fans 1, 3, 5, 7, 9          | Fans 2, 4, 6, 8, 10         |
| 6     | Fans 1, 3, 5, 7, 9, 11      | Fans 2, 4, 6, 8, 10, 12     |

### Normal Operation – Staging Up

At startup, the first fan will start when the saturated condenser temperature rises above the target. After this, the stage up deadbands apply.

When the saturated condenser temperature is above the Target + the active deadband, a Stage Up error is accumulated.

Stage Up Error Step = Saturated Condenser Refrigerant temperature – (Target + Stage Up dead band)

The Stage Up Error Step is added the Stage Up Accumulator once every Stage Up Error Delay seconds. When Stage Up Error Accumulator is greater than the Stage Up Error Set Point another stage is started.

When a stage up occurs or the saturated condenser temperature falls back within the Stage Up dead band the Stage Up Accumulator is reset to zero.

### Normal Operation – Staging Down

There are four Stage Down dead bands, one for each stage.

When the saturated condenser refrigerant temperature is below the condenser saturated temperature target – the active dead band, a Stage Down error is accumulated.

*Stage Down Error Step = (Target – Stage Down dead band) – Saturated Condenser Refrigerant temperature*

The Stage Down Error Step is added to Stage Down Accumulator once every Stage Down Error Delay seconds. When the Stage Down Accumulator is greater than the Stage Down Error Set Point another stage of condenser fans turn off. The last stage on will not shut off until the circuit is in an off state.



When stage down occurs or the saturated temperature rises back within the Stage Down dead band the Stage Down Error Accumulator is reset to zero.

### Forced Fan Stage at Start

Fans may be started simultaneously with the compressor based on outdoor ambient temperature. When the compressor starts, and after compressor operation is verified by either a 1 psi drop in evaporator or 1 psi rise in condenser pressures, a Fantrol stage is forced based on the following table.

| OAT    | Fantrol Stage At Start |
|--------|------------------------|
| >75°F  | Forced Fan 1 SP        |
| >90°F  | Forced Fan 2 SP        |
| >105°F | Forced Fan 3 SP        |

Up to four fans may be forced on when the compressor starts.

After forcing fans on, the saturated condenser temperature may temporarily stay below the target by some amount. In order to keep the fans from staging off, no stage down error can be accumulated until either the OAT drops below 75°F or the saturated condenser temperature goes above the target.

### Condenser Pump and Tower Control – Water Cooled

Condenser pump and cooling tower control logic requires that the unit be configured as water-cooled in order to be active.

### Condenser Water Pump State Control (Cond State)

If the unit is configured as water-cooled, then the state-transition diagram shown below defines the condenser pump control logic.

**Condenser Pump State Diagram**

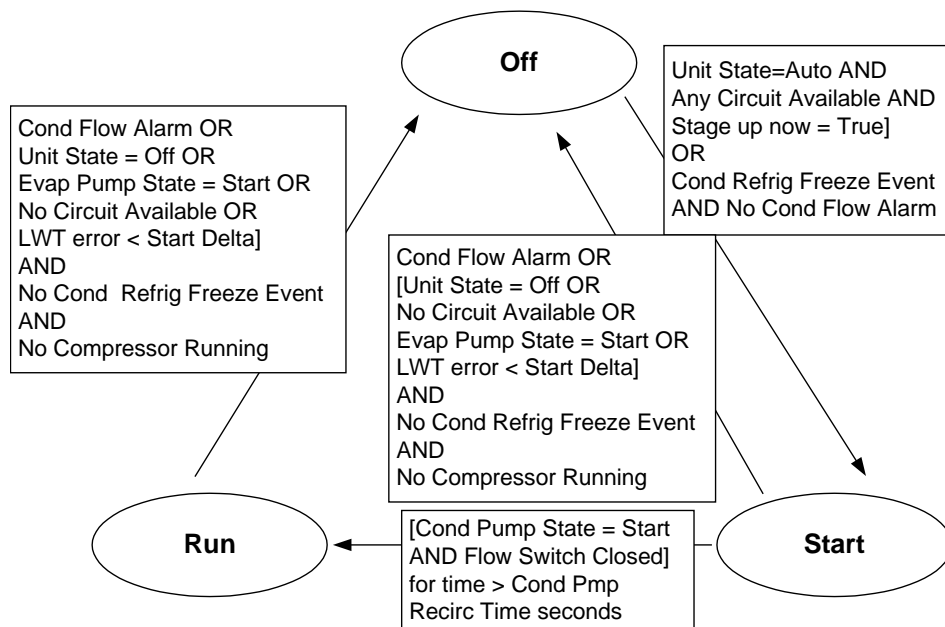

### Pump Selection

The pump output used will be determined by the Cond Pump Control set point. The setting allows the following configurations:

- #1 only – Pump 1 will always be used.
- #2 only – Pump 2 will always be used.

Auto – The primary pump is the one with the least run hours, the other is used as a backup.

#1 Primary – Pump 1 is used normally, with pump 2 as a backup.

#2 Primary – Pump 2 is used normally, with pump 1 as a backup.

## Primary/Standby Pump Staging

The pump designated as primary will start first. If the condenser state is start for a time greater than the re-circulate timeout set point and there is no flow, then the primary pump will shut off and the standby pump will start. When the condenser is in the run state, if flow is lost for more than half of the flow proof set point value, the primary pump will shut off and the standby pump will start. Once the standby pump is started, the flow loss alarm logic will apply if flow cannot be established in the condenser start state, or if the flow is lost in the condenser run state.

## Auto Control

If auto pump control is selected, the primary/standby logic above is still used. When the condenser is not in the run state, the run hours of the pumps will be compared. The pump with the least hours will be designated as the primary at this time

## Condenser Water Flow Loss

The Condenser Water Flow Loss logic allows the Unit to shutdown compressors on a loss of flow up to two times every twenty-four hours before locking the unit out on a Condenser Flow Loss Alarm.

- If there are no compressors running when Condenser Water Flow Loss is indicated the Unit Status changes to Auto:Wait for flow. The condenser water pump state changes to Start and no alarms are indicated.
- If a Condenser Water Flow Loss occurs while a compressor is running all of the running compressors will be shutdown. The Alarm indicators are turned On and the Circuit Status for any circuit with running compressors becomes Off: Ready, the Unit Status becomes Auto: Wait For Flow and the condenser water pump state changes to Start
- When flow is reestablished the Unit Status becomes Auto: Recirculate while the Condenser Flow Recirculation Timer counts down. If there is continuous evaporator water flow while the Condenser Recirculation Timer counts down the Alarm indicator is turned off, and the Unit resumes normal start up procedures based on water temperature and cycle timers.
- If second Condenser Water Flow Loss occurs within twenty-four hours the process described above is repeated.
- If a third loss of flow is indicated in twenty-four hour time frame the Unit will shut down on an Condenser Water Flow Loss alarm and it will be locked out until this alarm is manually cleared.
- The twenty-four hour timer that limits the auto restart is reset when the control clock rolls over 00:00 each night.

## Tower Fans

Tower fan control is active when the unit is set up as water cooled (WaterCooled=On), Tower Control is set to Temperature, and the condenser pump is in the RUN state. Staging is based on Entering Condenser Water Temperature (ECWT). Operation depends on the following parameters.

Condenser pump state

ECWT

Stage up and stage down timer values

Tower set points (Tower Control, Tower Stages, Stage Up Time, Stage Down Time, Stage Differential ,Stage #1 ON, Stage #2 ON, Stage Down @, Stage Up @)

When the condenser pump starts, the stage up timer shall start. The first stage shall turn ON when the following conditions are met:

The stage up timer completes

The ECWT is > Stage #1 ON set point

Bypass valve position is > the Stage Up @ set point (only if Valve/VFD Control set point = Valve Stage)

Additional stages can turn on (up to the number specified by the Tower Stages set point) when above conditions are met for the next stage plus the following condition:  
 VFD Speed is > the Stage Up @ set point (only if Valve/VFD Control set point = VFD Stage OR Valve SP/VFD Stage)

Down staging shall occur when the following conditions are met:

The stage down timer completes

The ECWT is < Stage #X ON (Temp) set point – Stage Differential (Temp) set point

Bypass valve position is < the Stage Down @ set point (only if Valve/VFD Control set point = Valve Stage)

VFD Speed is < the Stage Down @ set point (only if Valve/VFD Control set point = VFD Stage OR Valve SP/VFD Stage)

Each stage up or stage down event will restart both the stage up and stage down timers. Only one fan output will be switched at a time (except that all outputs switch OFF when the condenser pump state equals OFF).

### Cooling Tower Bypass Valve

When the Valve/VFD Control set point is set to None OR VFD Stage, this output will be set to 0.

Otherwise, it shall be controlled as described below.

### Initial Valve Position

When the condenser pump is not in the RUN state, the valve output will be set as a function of entering condenser water temperature (ECWT) per the following graph.

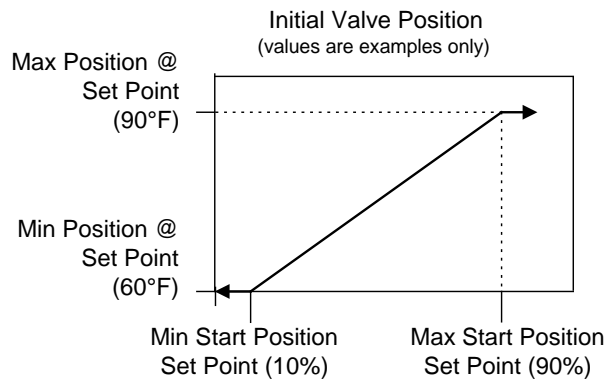

### Operation After Start

When the condenser pump is in the RUN state, the valve output will be controlled in one of two modes as specified by the Valve/VFD Control set point. The controlled parameter will be the condenser entering water temperature. When the desired output signal varies from 0 to 100%, the output voltage will vary as shown below.

0 to 10 VDC (Valve Type = NC to tower)

10 to 0 VDC (Valve Type = NO to tower)

### Valve Set Point Mode

This mode is operational when the Valve/VFD Control set point is set to Valve Set Point OR Valve SP/VFD Stage. In this mode the valve output is varied with a proportional-derivative (PD) algorithm (with dead band) in order to maintain the controlled parameter (CP) at the desired value. The output is always limited between the Valve Control Range (Min) set point and the Valve Control Range (Max) set point. A valve increment shall be computed once every 5 seconds according to the following equation.  

$$\text{Increment} = [(\text{Error}) * (\text{Error Gain set point})] + [(\text{Slope}) * (\text{Slope Gain set point})]$$

Where: Error = ECWT – Valve Set Point Slope = (Present CP) – (Previous CP)

When the Error is > the Valve Deadband set point, the valve position analog output (% of full scale) is updated according to the following equation.

$$\text{New \%Position} = \text{Old \%Position} + \text{Increment}/10.$$

## Valve Stage Mode

This mode is only operational when the Valve/VFD Control set point is set to Valve Stage. In this mode the valve output is controlled as for Valve Set Point mode (above) except that the active set point for the controlled parameter is selected according to the following table.

| Number Of Fans ON | Active Set Point |
|-------------------|------------------|
| 0                 | Valve Set Point  |
| 1                 | Stage #1 ON      |
| 2                 | Stage #2 ON      |

## Cooling Tower Fan VFD

When the Valve/VFD Control set point is set to None, Valve Setpoint, OR Valve Stage, this output will be set to 0. Otherwise, it will be controlled in a manner identical to Valve Stage Mode (above) except that (1) it will be kept at zero until the first fan stage is ON and (2) the following set points do not apply.

Valve Control Range (Min)

Valve Control Range (Max)

Valve Type

## Compressor Start/Stop Timing

This section determines when to start or stop a compressor. There are two separate functions used, one for staging up and one for staging down.

### Stage Up Now

The **Stage Up Now** flag is set based on the following tests:

If Unit mode = Cool AND  
no compressors are running AND  
LWT error > Start delta + 0.5 \* Control Band AND  
Motor Protect Timer expired AND  
Stage up timer expired THEN  
**Stage Up Now** = True

If Unit Mode = Cool AND  
At least one compressor is running AND  
LWT error > 0.5 \* Control band AND  
Pulldown rate <= Max pulldown rate AND  
Compressors running < unit capacity limit AND  
Stage up timer expired THEN  
**Stage Up Now** = True

If Unit mode = Heat AND  
no compressors are running AND  
LWT error > Start delta + 0.5 \* Control Band AND  
Motor Protect Timer expired AND  
Stage up timer expired THEN  
**Stage Up Now** = True

If Unit Mode = Heat AND  
At least one compressor is running AND  
LWT error > 0.5 \* Control band AND  
Pulldown rate <= Max pulldown rate AND  
Compressors running < unit capacity limit AND  
Stage up timer expired THEN  
**Stage Up Now** = True

## Stage Down Now

The **Stage Down Now** flag is set based on the following tests:

If Unit Mode = Cool AND  
LWT error <  $-0.5 * \text{Control band}$  AND  
More than one compressor running AND  
Stage down timer expired THEN  
**Stage Down Now** = True

If Unit Mode = Cool AND  
LWT error <  $(-0.5 * \text{Control band} - \text{stop delta})$  AND  
One compressor running AND  
Stage down timer expired THEN  
**Stage Down Now** = True

If Unit Mode = Cool AND  
Number of compressors running > Demand limit AND  
Stage down timer expired THEN  
**Stage Down Now** = True

If Unit Mode = Heat AND  
LWT error <  $-0.5 * \text{Control band}$  AND  
More than one compressor running AND  
Stage down timer expired THEN  
**Stage Down Now** = True

If Unit Mode = Heat AND  
LWT error <  $(-0.5 * \text{Control band} - \text{stop delta})$  AND  
One compressor running AND  
Stage down timer expired THEN  
**Stage Down Now** = True

## Compressor Sequencing

Compressor staging is based primarily on compressor run hours and starts. Compressors that have less starts will normally start before those with more starts. Compressors that have more run hours will normally shut off before those with less run hours. In the event of a tie on number of starts, the lower numbered compressor starts first. In the event of a tie on run hours, the lower numbered compressor shuts off first. Run hours are compared in terms of tens of hours.

If possible, only one compressor per circuit will start before starting the second compressor on any circuit. If a circuit is unavailable for any reason, the other circuit shall be allowed to stage the second compressor on. When staging down, one compressor on each circuit shall be left on until each circuit has only one compressor running.

## Low Ambient Start (WaterCooled = NO)

In order to avoid low evaporator pressure alarms at startup, low OAT start logic allows for running at low evaporator pressures for a longer time than normal as well allowing multiple compressor restart attempts before locking out the circuit.

### Low Ambient Start Procedure

A low OAT start is initiated if the condenser refrigerant saturated temperature is less than 85.0°F when the first compressor starts. Once the compressor starts the circuit is in a low OAT start state for a time equal to the Low OAT Start Time set point. During Low OAT Starts, the freezestat logic and low evaporator pressure events are disabled. The absolute limit for low evaporator pressure is enforced and the

compressor will shutdown if the evaporator pressure gets down to 5.0 psi. For R410a, the absolute limit for low evaporator pressure is 20.0 psi.

When the Low OAT Start Timer has expired, if the evaporator pressure is greater than or equal to the Low Evaporator Pressure Unload set point, the start is considered successful and normal alarm and event logic is reinstated. If the evaporator pressure is less than the Low Evaporator Pressure Unload set point when the Low OAT Start Timer expires, the start is unsuccessful and the compressor will shutdown.

Three compressor restarts per circuit are allowed when a circuit fails to start a compressor in a Low Ambient Start attempt. On the third failed Low Ambient Start attempt the Restart Alarm is triggered and the circuit will not attempt to restart a compressor until the Restart alarm has been cleared.

### Circuit Capacity Overrides

The following conditions shall override the automatic capacity control when the chiller is in cool mode only. These overrides keep a circuit from entering a condition in which it is not designed to run.

#### Low Evaporator Pressure

If a compressor in a circuit is running and the evaporator pressure drops below the Low Evaporator Pressure Hold set point, no more compressors will be allowed to start on that circuit. The limit shall be active until the evaporator pressure reaches the hold Low Evaporator Hold set point plus 8.0 psi for R134a and R407C or 13.0 psi for R410A. On that circuit's VIEW CIRCUITn (1) screen is displayed the "Hold Clear @" value which is the limit by which the evaporator pressure must reach to allow for additional loading. A Low Evaporator Pressure Hold event will be recorded in the Event Log.

If two or more compressors are running in a circuit and the evaporator pressure drops below the Low Evaporator Pressure Unload set point, the circuit will begin reducing capacity. If two compressors are running, one of the compressors will be stopped after a time delay has expired which is one-half the calculated freeze time (lower pressure then shorter time). If three compressors are running, one compressor will stop after a this time delay which is one-half the calculated freeze time and, ten seconds later, if the pressure has not risen above the unload set point an additional compressor will be stopped. The last compressor on a circuit will not stop due to the unload condition. The low evaporator pressure unload event will clear when the evaporator pressure rises either 8.0 psi for R134a and R407C or 13.0 psi for R410A above the Low Evaporator Pressure Hold set point. A Low Evaporator Pressure Unload event will be recorded in the Event Log.

If the evaporator pressure drops below the Low Evaporator Pressure Unload set point and one compressor on the circuit is running then the following table applies.

| Description | Low Evap Press Time    | Requirement to continue              |
|-------------|------------------------|--------------------------------------|
| Check #1    | 15 seconds after start | Evap Press >(0.48*Low Evap Press SP) |
| Check #2    | 30 seconds after start | Evap Press >(0.66*Low Evap Press SP) |
| Check #3    | 45 seconds after start | Evap Press >(0.83*Low Evap Press SP) |
| Check #4    | 60 seconds after start | Evap Press > Low Evap Press SP       |

#### High Condenser Pressure – Unload Logic

If the discharge pressure rises above the High Condenser Pressure Unload set point and more than one compressor on the circuit is running, the circuit will stage down. One compressor will shut down as soon as the pressure rises above the unload set point and if two remain running then one more will shut down 10 seconds later if the pressure is still above the unload set point. On that circuit's VIEW CIRCUITn (1) screen is displayed the "Hold Clear @" value which is the limit by which the condenser pressure must drop to allow for additional loading. A High Condenser Pressure Unload event will be recorded in the Event Log.

No stage up will be allowed on the circuit until the condenser pressure drops below the unload set point less an offset value which is calculated based on 1) type refrigerant, 2) number of compressors, 3) condenser configuration, and 4) how many high pressure unload occurrences since the previous mid-night. See below for initial offset value and step-increase for each additional occurrence.

Hold Clear Reset Value =

$High\ Pressure\ Unload\ set\ point - [“Initial\ Offset” + [“Step-Increase” \times [“number\ of\ occurrence” - 1]]]$

**Initial Offset & Step Increase**

| Condenser Configuration | No. of Compressors | R410A   | R407C  | R134a  | Step Increase |
|-------------------------|--------------------|---------|--------|--------|---------------|
| Water-Cooled            | 4                  | 40 psi  | 30 psi | 30 psi | 10 psi        |
|                         | 6                  | 32 psi  | N/A    | 20 psi | 10 psi        |
| Air-Cooled              | 4                  | 100 psi | 70 psi | N/A    | 15 psi        |
|                         | 6                  | 80 psi  | N/A    | N/A    | 15 psi        |

**Example of Operation:** Assume a packaged water-cooled WGZ unit with 4 compressors using R410A as the refrigerant. Circuit number one is fully loaded (both compressors running) when that circuit’s condenser pressure exceeds the High Condenser Pressure Unload set point. Circuit number one will unload by turning one of the two compressors off immediately. This circuit will not be allowed to load back up until its condenser pressure decreases below the “Hold Clear @” value which is displayed on the “VIEW CIRCUIT 1 (1)” screen. Since this is the first High Condenser Pressure – Unload occurrence for that circuit, the circuit will be allowed to load once the condenser pressure drops below the High Condenser Pressure Unload set point minus 40 psi. If using default value (405 psi) this will be 365 psi. After some time, the condenser pressure is allowed to decrease below this value and circuit number one is again allowed to load up. Again its condenser pressure exceeds the High Condenser Pressure Unload set point and it unloads. Because this is the second High Condenser Pressure – Unload occurrence for that circuit, the circuit will not be allowed to load until the condenser pressure drops below the High Condenser Pressure Unload set point minus 50 psig (40 psi plus step-increase 10psi). If using default values, this will be 355 psi. As you can see, for each occurrence the discharge pressure must get lower and lower (based on Step-Increase value) before the circuit is allowed to again load. This logic is intended to prevent excessive cycling of compressors.

**Unit Capacity Overrides**

The following conditions override the automatic capacity control when the chiller is in cool mode only.

**Demand Limit**

The maximum unit capacity can be limited by a 4 to 20 mA signal on the Demand Limit analog input. This function is only enabled if the Demand Limit set point is set to ON. The maximum unit capacity stage is determined as shown in the following graph.

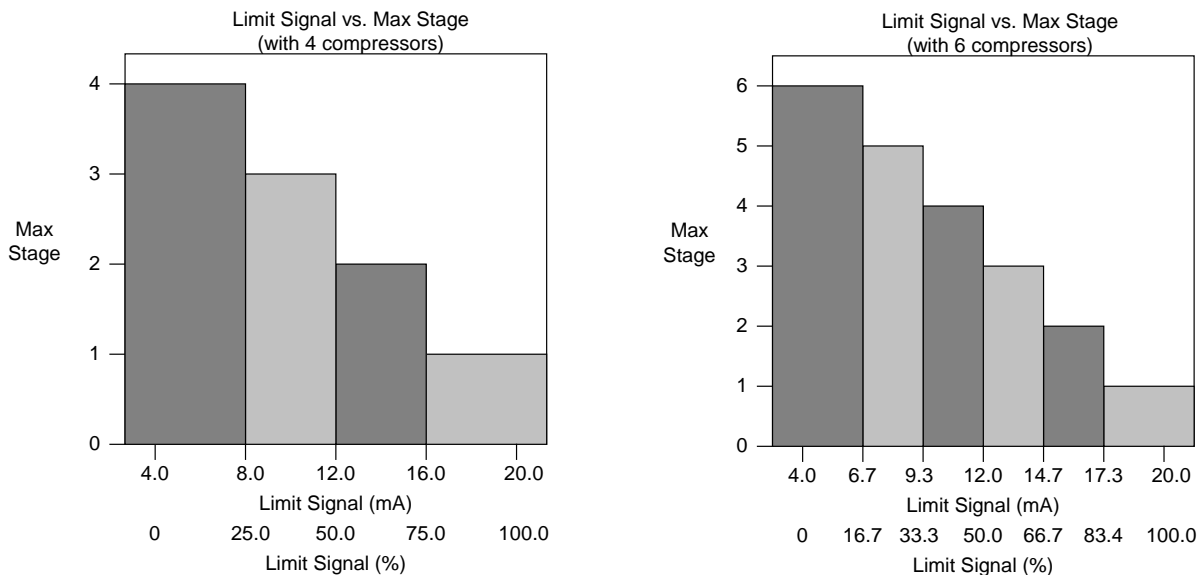

Any signal less than 4 mA does not limit the chiller capacity.

## Network Limit

The maximum unit capacity can be limited by a network signal. This function is only enabled if the unit control source is set to network. The maximum unit capacity stage is based on the network limit value received from the BAS, and is determined as shown in the following graph.

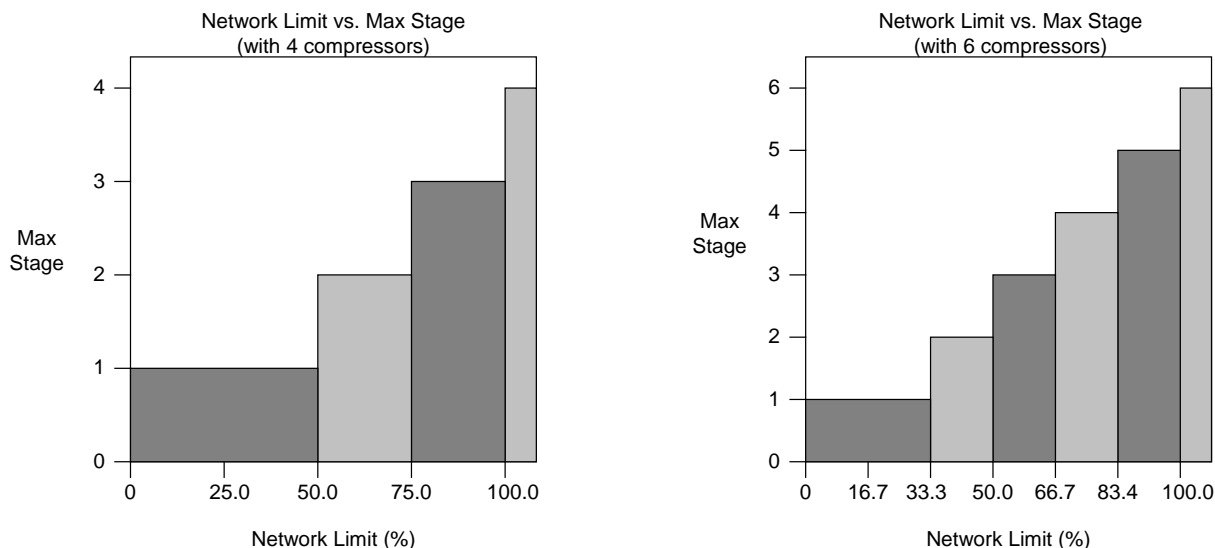

In order to allow all stages to run, a signal of 100.0% is required.

## Maximum LWT Rate

The maximum rate at which the leaving water temperature can drop is limited by the Maximum Pull Down Rate set point when the unit mode is cool. If the rate exceeds this set point, no more compressors shall be started until the pull down rate is less than the set point. Running compressors will not be stopped as a result of exceeding the maximum pull down rate.

## Low Ambient Lockout (Water Cooled = NO Only)

If the OAT drops below the low ambient lockout set point, then all running circuits will do a normal stop, after the compressors have stopped the evaporator water pump will stop. Once the lockout has been triggered, the evaporator water pump will remain off and no compressors will start until the OAT rises to the lockout set point plus 5°F.

## Manual Compressor Control

The operator can manually enable and disable individual compressors. When a compressor has been disabled it is considered unavailable to start in the staging logic. With Manual Compressor control it is possible to take a damaged compressor offline while the remaining compressors on the circuit can still provide some cooling.

A running compressor cannot be disabled until it has been shutdown. If both of the compressors on a circuit have been disabled then the circuit is disabled. If both circuits have all of their compressors disabled, the Unit state will remain "Off".

## Normal Circuit Shutdown

If a condition arises that requires a circuit to shut down, but it is not an emergency situation, then the circuit will do a pump down. A normal circuit shutdown will be initiated when any of the following occur:

- Unit State = Pump Down
- Circuit Switch = Off
- Low Ambient Lockout



- A normal stage down occurs, and only one compressor on the circuit is running
- Unit mode = Ice AND the ice set point is reached

### Pump Down Procedure

- If both compressors are running, shut off the appropriate compressor based on sequencing logic
- With one compressor left running, turn off hot gas output and liquid line output
- Keep running until evaporator pressure reaches the pump down pressure, then stop compressor
- If evaporator pressure does not reach pump down pressure within two minutes, stop compressor and record a Failed Pumpdown event in the Event Log.

### Rapid Circuit Shutdown

A situation may arise that requires a circuit to shut down immediately, without doing a pumpdown. This rapid shutdown will be triggered by any of the following:

Unit State = Off  
 Circuit Alarm  
 Low ambient start attempt failed

All compressors, hot gas, and liquid line outputs should be turned off immediately for a rapid shutdown.

### Liquid Line Solenoid

The liquid line output shall be on any time a compressor on the circuit is running and the circuit is not performing a pump down. This output should be off at all other times.

### Hot Gas Bypass Solenoid

This output shall be on when one compressor on the circuit is running and the circuit is not performing a pump down. The output should be off at all other times including the delay time described below.

The hot gas bypass valve opening will be delayed for Hot Gas Bypass Time set point seconds (the default is 30 seconds) when the first compressor starts on each circuit.

### EXV Control

The EXV control logic is active regardless of the expansion valve type setting. While a circuit is in the run state, the EXV controls suction superheat. The superheat target is 8°F. PID logic will be used to control the superheat to the target value.

Any time the circuit is not in the run state, the EXV position should be 0.

### EXV Control Range

The table below shows the EXV range based on the number of compressors running and number of compressors on unit.

| Number of Compressors | Valve Position | Compressors Running |      |     |
|-----------------------|----------------|---------------------|------|-----|
|                       |                | 1                   | 2    | 3   |
| 4                     | EXV Min        | 8%                  | 8%   | -   |
|                       | EXV Max        | 60%                 | 100% | -   |
| 6                     | EXV Min        | 8%                  | 8%   | 8%  |
|                       | EXV Max        | 35%                 | 45%  | 65% |

## **Manual EXV Control**

The EXV position can be set manually. Manual control can only be selected when the circuit is in the run state. At any other time, the EXV control set point is forced to auto.

When EXV control is set to auto, the manual EXV position setting follows the auto control position. When EXV control is set to manual, the EXV position is equal to the manual EXV position setting.

## **Maximum EXV Operating Pressure**

This logic only applies to TGZ units (Refrig = R134a) equipped with electronic expansion valves. The purpose of this logic is to prevent the operating circuit's evaporator pressure from exceeding the 'MaxOpPress' set point (found on "SET COMP SPs (6) screen) and overloading the compressors. The electronic expansion valves (EEV) will close to prevent the operating circuit's evaporator pressure from exceeding the 'MaxOpPress' set point.

# Using the Controller

---

## Getting Started

There are two basic procedures to learn in order to utilize the MicroTech II controller:

- Navigating through the menu matrix to reach a desired menu screen and knowing where a particular screen is located.
- Knowing what is contained in a menu screen and how to read that information or how to change a setpoint contained in the menu screen.

## Navigating Through the Menus

The menus are arranged in a matrix of screens across a top horizontal row. Some of these top-level screens have sub-screens located under them. The general content of each screen and its location in the matrix are shown in Figure 10. (A detailed description of each menu begins on page 53.) There are two ways to navigate through the menu matrix to reach a desired menu screen.

One is to scroll through the matrix from one screen to another using the four ARROW keys.

The other way is to use shortcuts to work through the matrix hierarchy. From any menu screen, pressing the MENU key will take you to the top level of the hierarchy. The display will show ALARM, VIEW, and SET as shown in Figure 8. This corresponds to the second row of screens on Figure 10. One of these groups of screens can then be selected by pressing the key connected to it via the pathway shown in Figure 8 on page 18.

For example, selecting ALARM will go the next row of menus under ALARM (ALARM LOG or ACTIVE ALARM). Selecting VIEW will go the next level of screens under VIEW (VIEW UNIT STATUS or VIEW UNIT TEMP). Selecting SET will go to a series of screens for looking at and changing setpoints.

After pressing the MENU button, the top-level menu screen will show:

```
< ALARM
< VIEW
< SET
<
```

After pressing the "VIEW" menu button, a menu screen will show:

```
VIEW < COMPRESSOR
< UNIT
< EVAPORATOR
< FANS
```

After pressing the "EVAPORATOR" menu button, the selected data screen will show:

```
VIEW EVAP
(screen data)
(screen data)
(screen data)
```

The arrow keys will automatically return to the "scroll" mode at this time.

## MENU Key

The MENU key is used to switch between the shortcut method (known as the MENU mode and as shown in Figure 8) and scrolling method (known as the SCROLL mode). The MENU mode is the shortcut to specific groups of menus used for checking ALARMS, for VIEWING information, or to SET setpoint values. The SCROLL mode allows the user to move about the matrix (from one menu to another, one at a time) by using the four ARROW keys. A typical menu screen is shown in the following figure. Pressing the MENU key from any menu screen will automatically return you to the MENU mode.

**Figure 9, Display in the Shortcut (SCROLL) Mode and Keypad Layout**

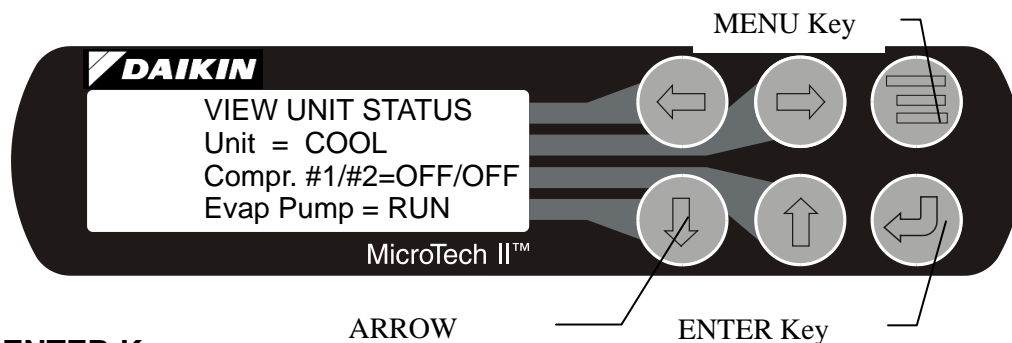

### **ENTER Key**

Pressing the ENTER key changes the function of the ARROW keys to the editing function as shown below:

LEFT key Default, changes a value to the factory-set default value.

RIGHT key Cancel, cancels any change made to a value and returns to the original setting.

UP key Increment, increases the value of the setting

DOWN key Decrement decreases the value of a setting.

These four edit functions are indicated by one-character abbreviation on the right side of the display (this mode is entered by pressing the ENTER key).

Most menus containing setpoint values have several different setpoints shown on one menu. When in a setpoint menu, the ENTER key is used to proceed from the top line to the second line and on downward. The cursor will blink at the entry point for making a change. The ARROW keys (now in the edit mode) are used to change the setpoint as described above. When the change has been made, press the ENTER key to enter it. Nothing is changed until the ENTER key is pressed.

For example, to change the chilled water setpoint:

1. Press MENU key to go to the MENU mode.
2. Press SET (the UP Key) to go to the setpoint menus.
3. Press UNIT SPs (the Right key) to go to setpoints associated with unit operation.
4. Press the DOWN key to scroll down through the setpoint menus to the third menu which contains Evap LWT=XX.X°F.
5. Press the ENTER key to move the cursor down from the top line to the second line in order to make the change.
6. Use the ARROW keys (now in the edit mode as shown above) to change the setting.
7. When the desired value is achieved, press ENTER to enter it and also move the cursor down.

At this point, the following actions can be taken:

1. Change another setpoint in this menu by scrolling to it with the ENTER key.
2. Using the ENTER key, scroll to the first line in the menu. From there the ARROW keys can be used to scroll to different menus.

## **Menu Screens**

Various menus are shown in the controller display. Each menu screen shows specific information, in some cases menus are only to *view* status of the unit, in some cases for checking *alarms*, and in some cases they are used to *set* setpoint values that can be changed.

The menus are arranged in a matrix of screens across a top horizontal row. Some of these top-level screens have sub-screens located under them. The content of each screen and its location in the matrix are shown in Figure 10. A description of each menu begins on page 53.

The arrow keys on the controller are used to navigate through the menus. The keys are also used to change numerical setpoint values contained in certain menus.

**Figure 10, Menu Matrix**

| "VIEW" MENUS         |                    |                         |                         |                                 |                                 |                    |                |
|----------------------|--------------------|-------------------------|-------------------------|---------------------------------|---------------------------------|--------------------|----------------|
| UNIT                 |                    | CIRCUITS                |                         | REFRIGERANT                     |                                 | FANS               | EVENTS         |
| VIEW UNIT STATUS (1) | VIEW UNIT TEMP (1) | VIEW CIRC #1 STATUS (1) | VIEW CIRC #2 STATUS (1) | VIEW REFRIGERANT CIRCUIT #1 (1) | VIEW REFRIGERANT CIRCUIT #2 (1) | VIEW FAN/TOWER (1) | VIEW EVENT (1) |
| VIEW UNIT STATUS (5) | VIEW UNIT TEMP (2) | VIEW COMP #1 STATUS (3) | VIEW CIRC #2 STATUS (3) | VIEW EVAP (2)                   | VIEW EVAP (2)                   | VIEW FAN/TOWER (n) | VIEW EVENT (n) |

"MENU" →

← Continued ←

(Right side of matrix continued from above)

| "ALARM" MENUS               |  | "SET" MENUS               |                  |                      |                             |                  | TEST          |
|-----------------------------|--|---------------------------|------------------|----------------------|-----------------------------|------------------|---------------|
| ALARM LOG (LAST) TYPE, TIME | ACTIVE ALARM (1) TYPE, TIME            | SET UNIT SPs, (1)         | SET COMP SPs (1) | SET LIMIT ALARMS (1) | SET FANS (1) STAGES FANTROL | SET TOWER (1)    | TEST UNIT (1) |
| ALARM LOG (NEXT TO LAST)    | ACTIVE ALARM (2) TYPE, TIME ADDITIONAL | SET UNIT SPs, (2)         | SET COMP SPs (2) | SET LIMIT ALARMS (2) | SET FANS (2) STAGE ON       | SET TOWER (2)    |               |
| ALARM LOG (SECOND TO LAST)  | ACTIVE ALARM (3) CLEAR/VIEW            | SET UNIT SPs, (3)         |                  | SET LIMIT ALARMS (3) | SET FANS (3) STAGE OFF      | SET TOWER (3)    |               |
| ALARM LOG LAST 25 SHOWN     |  | SET UNIT SPs, (4) (to 13) |                  |                      |                             | SET TOWER (to n) | TEST UNIT (7) |

Selection can be made within the matrix by using the LEFT/RIGHT keys to move between columns and the UP/DOWN keys to move between rows.

## Menu Descriptions

This section contains information on each screen. The menu screens are in order of the matrix in Figure 10 going from left to right and down when there are sub-menus. Many menus are self-explanatory. A Setpoint menu allows selection of whether the unit has a water-cooled condenser, WaterCooled = Y (Yes) or a remote condenser, WaterCooled = N (No). This selection will alter some menus as appropriate to the type of condenser.

### Screen Definitions – MENU

Top level menu:

|   |       |
|---|-------|
| < | ALARM |
| < | VIEW  |
| < | SET   |
| < |       |

ALARM menu:

|       |   |        |
|-------|---|--------|
| ALARM | < | ACTIVE |
|       | < | LOG    |
|       | < |        |
|       | < |        |

### VIEW menu:

```
VIEW < COMPRESSOR
      <          UNIT
      < EVAPORATOR
      < FANS/TOWER
```

### VIEW UNIT menu:

```
VIEW <          TEMP
UNIT  <          STATUS
      < REFRIGERANT
```

### SET menu:

```
SET < ALARM LIMITS
     <          UNIT SPs
     < COMPRESSOR SPs
     < FANS/TOWER SPs
```

## Screen Definitions – VIEW

### View Unit Status

```
VIEW UNIT STATUS (1)
Auto
Cooling Stage = 0
Evap Pump = RUN
```

Unit states can be OFF, COOL, GYLCOL, ICE, or ALARM as determined from the Unit Mode setpoint, the Unit Enable, and the presence of an alarm.

Circuit states can be OFF/OFF, ON/OFF, OFF/ON, and ON/ON.

Evaporator Pump States can be OFF, STRT, or RUN.

When more than one screen are stacked (i.e., relate to each other on the same subject), they are numbered sequentially with the numbers appearing in the upper-right corner.

```
VIEW UNIT STATUS (2)
Demand Limit=Stg 4
Network Limit=Stg 4
```

```
VIEW UNIT STATUS (3)
Stg Up Delay=XXX sec
Stg Dn Delay=XXX sec
Ice Delay=XXh XXm
```

```
VIEW UNIT STATUS (4)
D.O.      111111111
123456789012345678
000000000000000000
```

This menu gives the status of digital outputs (D.O.), 1=ON, 0=OFF. Numbers are 1 through 18. See Table 6 on page 19 for number reference.

```
VIEW UNIT STATUS (5)
D.I.      111111111
123456789012345678
000000000000000000
```

This menu gives the status of digital inputs (D.I.), 1=ON, 0=OFF. Numbers are 1 through 18. See Table 5 on page 19 for number reference.

```
VIEW UNIT STATUS (6)
  Analog Output
  (volts x 100)
  1 = 000.0  2 =
000.0
```

```
VIEW UNIT STATUS (7)
  Analog Output
  (volts x 100)
  3 = 000.0  4 =
000.0
```

```
VIEW UNIT STATUS (8)
EXB1 Online
D.O.  1  2  3  4
      0  0  0  0
```

### View Unit Temperatures

Water Cooled = Y

#### TGZ in Cool Mode

```
VIEW UNIT TEMP (1)
Evap LWT = XX.X°F
Cond EWT = XXX.X°F
LWT Target = XX.X°F
```

Water Cooled = N

```
VIEW UNIT TEMP (1)
Evap LWT = XX.X°F
OAT = XXX.X°F
LWT Target = XX.X°F
```

#### TGZ Unit in Heat Mode (R134a)

```
VIEW UNIT TEMP (1)
Evap LWT = XX.X°F
Cond EWT = XXX.X°F
LWT Target = XX.X°F
```

The difference between the three screens above is that water-cooled units and the TGZ units will give the entering condenser water temperature and air-cooled units will give the outside air temperature (OAT). The outside-air temperature sensor is furnished with the unit, inside the control panel, wired to the correct terminals. It must be installed outdoors in a location that will give the true outdoor temperature that the condenser coils will see. Splicing of the sensor lead may be required. The unit will not operate without the sensor installed.

#### WGZ unit

```
VIEW UNIT TEMP (2)
LWT Pulldn= XX.X °F
Control Band= XX.X°F
```

#### TGZ Unit (R134a)

```
VIEW UNIT TEMP (2)
LWT Pulldn= XX.X °F
Control Band= XX.X°F
```

```
VIEW UNIT TEMP (3)
Control Temps
Start Up XX.X°F
Stage Up XX.X°F
```

```
VIEW UNIT TEMP (4)
Control Temps
Stage Down XX.X°F
Shut Down XX.X°F
```

**TGZ Unit Only in Cool Mode**

```
VIEW UNIT TEMP (5)
Cond LWT XX.X°F
Evap EWT XX.X°F
```

**TGZ Unit Only in Heat Mode**

```
VIEW UNIT TEMP (5)
Cond LWT XX.X°F
Evap EWT XX.X°F
```

**View Circuit**

```
VIEW CIRCUIT#1 (1)
OFF
```

```
VIEW CIRCUIT#1 (2)
Comp 1 = OFF
Hours = XXXXX
Starts = XXXXX
```

```
VIEW CIRCUIT#1 (3)
Comp 3 = OFF
Hours = XXXXX
Starts = XXXXX
```

**If # of Compressors = 6  
Only for R410A or R134a**

```
VIEW CIRCUIT 1 (4)
Comp5=Off
Hours = XXXXX
Starts = XXXXX
```

```
VIEW CIRCUIT 2 (1)
Off
```

```
VIEW CIRCUIT#2 (2)
Comp 2 = OFF
Hours = XXXXX
Starts = XXXXX
```



```
VIEW CIRCUIT#2 (3)
Comp 4 = OFF
Hours = XXXXX
Starts = XXXXX
```

If # of Compresors = 6  
Only for R410A or R134a

```
VIEW CIRCUIT 1 (4)
Comp6=Off
Hours = XXXXX
Starts = XXXXX
```

### View Refrigerant

```
VIEW REFRG Cir 1 (1)
Evap Press XXX.X psi
Cond Press XXX.X psi
```

### R 134a, R410A

```
VIEW REFRG Cir 1 (2)
Sat Evap XXX.X °F
Sat Cond XXX.X °F i
```

```
VIEW REFRG Cir 1 (3)
SuctionTemp=XXX.X°F
Surperheat = XXX.X°F
EvapApproach= XX.X°F
```

### TGZ Only (R134a)

```
VIEW REFRG Cir 1 (4)
LiqLineTemp=XXX.X°F
Subcooling = XXX.X°F
CondApproach= XX.X°F
```

### Units with EEV only

```
VIEW REFRG Cir 1 (5)
EXV Ctrl = XXX
EXV Pos = XXX.X%
SH Target = XX.X°F
```

### TGZ Units Only (R134a)

```
VIEW REFRG Cir 1 (6)
EXV Ctrl Range
XX.X% ---XX.X%
```

### R407C

```
VIEW REFRG Cir 1 (2)
Evap Dew XXX.X °F
Cond. Mid XXX.X °F
```

```
VIEW REFRG Cir 2 (1)
Evap Press XXX.X psi
Cond Press XXX.X psi
```

#### R 134a, R410A

```
VIEW REFRG Cir 2 (2)
Sat Evap XXX.X °F
Sat Cond XXX.X °F i
```

#### R407C

```
VIEW REFRG Cir 2 (2)
Evap Dew XXX.X °F
Cond. Mid XXX.X °F
```

```
VIEW REFRG Cir 2 (3)
SuctionTemp=XXX.X°F
Surperheat = XXX.X°F
EvapApproach= XX.X°F
```

#### TGZ Only (R134a)

```
VIEW REFRG Cir 2 (4)
LiqLineTemp=XXX.X°F
Subcooling = XXX.X°F
CondApproach= XX.X°F
```

#### Units with EEV only

```
VIEW REFRG Cir 2 (5)
EXV Ctrl = XXX
EXV Pos = XXX.X%
SH Target = XX.X°F
```

#### TGZ Units Only (R134a)

```
VIEW REFRG Cir 2 (6)
EXV Ctrl Range
XX.X% ---XX.X%
```

#### Water Cooled = Y Only or TGZ Unit (R134a)

```
VIEW TOWER (1)
Stages ON = 1 of 2
EntCondTemp = XXX °F
Setpoint = XXX °F
```

The first Stages ON value is the number of fan stages ON. The second number is the Tower Stages setpoint (0 if Tower Control = None). This screen shows the number of tower fans “on” for each circuit. This screen will show the fans “on” whether they are actually connected to and controlled by the MicroTech II controller or not.

**Water Cooled = Y Only or  
TGZ Unit (R134a)**

```
VIEW TOWER (2)
Bypass Valve = XXX%
VFD Speed     = XXX%
```

The Bypass Valve value shall be “None” (in place of XXX%) if the Valve/VFD Control setpoint = None or VFD Stage. The VFD Speed value shall be “None” if the Valve/VFD Control setpoint = None, Valve Setpoint, or Valve Stage.

**Water Cooled = N Only**

```
VIEW FANS (1)
Fans On Circuit#1 =XX
Fans On Circuit#2 =XX
```

This screen shows the number of air-cooled condenser fans “on” for each circuit. This screen will show the fans “on” whether they are actually connected to and controlled by the MicroTech II controller or not.

```
VIEW FANS (2)
Stg Error Up   Down
Cir 1 =   XXX   XXX
Cir 2 =   XXX   XXX
```

```
VIEW FANS (3)
Sat Cond Target =
XXX.X
```

**Screen Definitions – ALARM**

```
ALARM ACTIVE (X)
Time      Date
Alarm Description
```

OR

```
ALARM ACTIVE (X)
No more alarms
Press ENTER to clear
all active alarms
```

If the unit is off on a shutdown alarm or running, but in a limit alarm condition, the cause and date will appear in the upper screen. If there is a simultaneous occurrence of more than one alarm, the others will appear in additional screens below the first one, accessed by the DOWN ARROW.

Either type alarm will light a red light in back of the LEFT-ARROW KEY. The light will go out when the fault is cleared. To clear the fault, scroll down to the last screen and press ENTER. If other faults have appeared, they will all be cleared at the same time. It is not necessary to have a password open to clear alarms.

```
ALARM LOG (X)
Alarm Description
Time      Date
Data Edit and scroll
```

The last 25 alarms, either shutdown or limit, are shown in this menu and subsequent menus located under it. ARROW DOWN from this menu will go to the next-to-last alarm, ARROW DOWN again will go to the second from last, and so on through the last 25 occurrences. The screens are numbered (1), (2), (3), etc.

## Screen Definitions – EVENT LOG

```
EVENT LOG (X)
Event Description
Time      Date
```

## Screen Definitions – SET

### Set Unit Setpoints

```
SET UNIT SPs (1)
Unit Enable = OFF
Unit Mode   = COOL
Source     = KEYPAD
```

Unit Enable settings can be OFF and ON as determined from the Unit Enable setpoint.

Unit Enable is an external signal or a keypad setting that keeps the unit off when the setting is OFF and *allows* it to run if there is a call for cooling when the setting is ON. The source for the signal is selected in the 4<sup>th</sup> line and can be:

- KEYPAD, in which case the selection is made in line 2 and would be normally selected as ON. This is the normal setting when no external signals are controlling the unit.
- SWITCHES, in which an external switch is wired across terminals #40 and #53. (See wiring diagram page 8 or 9.)
- NETWORK, used with BAS signal, which is wired to the three communication ports.
- Unit Mode settings can be
- COOL, normal setting used with chilled water air-condition applications.
- COOL w/GLYCOL, used with low temperature, glycol applications. It allows a lower LWT setpoint to be used.
- ICE w/GLYCOL, used with ice storage systems, allows changing from chilled glycol operation to lower temperature ICE operation. In ICE, the unit runs at full load until the ICE setpoint is reached, at which time the unit shuts off. A three-position switch wired to terminals #28 and #38 initiates the change from glycol cooling to making ice. (See wiring diagrams on page 8 or 9.)

Unit Mode settings can be COOL COOLw/Glycol, or ICEw/Glycol, as determined from the Unit Mode setpoint.

Source settings can be KEYPAD, SWITCHES, or NETWORK as determined from the Mode Source setpoint.

```
SET UNIT SPs (2)
Available Modes
=COOL
Set w/Unit Switch Off
```

```
SET UNIT SPs (3)
Evap LWT = XX.X°F
Ice LWT = XX.X°F
EvapDeltaT= XX.X°F
```

|                     |
|---------------------|
| SET UNIT SPs (4)    |
| Start Delta= XX.X°F |
| Stop Delta= XX.X°F  |
| Demand Limit = ON   |

See page 13 for an explanation of compressor staging.

**WGZ Units Only**

|                      |
|----------------------|
| SET UNIT SPs (5)     |
| Max Pulldn=X.X°F/min |
| Evap Recirc= XXX sec |
| Evap Pump = #1 Only  |

**TGZ Units Only (R134a)**

|                      |
|----------------------|
| SET UNIT SPs (5)     |
| Max Pulldn=X.X°F/min |
| Evap Recirc= XXX sec |
| Evap Pump = #1 Only  |

Evap Pump choices are; #1 Only, #2 Only, Auto, #1 Primary, #2 Primary.

**Water-Cooled = ON**

|                     |
|---------------------|
| SET UNIT SPs (6)    |
| Water Cooled = ON   |
| Cond Recirc=XXX sec |
| Cond Pump = #1 Only |

**Water-Cooled = OFF**

|                     |
|---------------------|
| SET UNIT SPs (6)    |
| Water Cooled = Off  |
| LowAmbLock XXX.X °F |

**TGZ Units (R134a)**

|                     |
|---------------------|
| SET UNIT SPs (6)    |
| Water Cooled = Off  |
| LowAmbLock XXX.X °F |

**Water Cooled = On** is the setting for units with on-board water-cooled condensers. Pump choices are; #1 Only, #2 Only, Auto, #1 Primary, #2 Primary.

**WaterCooled = OFF** is used for units with remote condensers, usually air cooled.

|                      |
|----------------------|
| SET UNIT SPs (7)     |
| Ice Time Delay=Xxsec |
| Clear Ice Delay=No   |
| H.G. Delay = XX sec  |

H.G. Delay, hot gas bypass delay, keeps the hot gas solenoid valve closed when the first compressor on a circuit starts. This delay allows sufficient condenser pressure to build up.

|                  |
|------------------|
| SET UNIT SPs (8) |
| CLOCK            |
| dd/mm/yy         |
| hh:mm:ss         |

|                  |                  |
|------------------|------------------|
| SET UNIT SPs (9) | SET UNIT SPs (9) |
| Units = °F/psi   | Units = °F/psi   |
| Lang = ENGLISH   | Lang = ENGLISH   |
| Refrig = None    | Refrig = R407C   |

|   |   |
|---|---|
| <b>SET UNIT SPs (9)</b><br>Units = °F/psi<br>Lang = ENGLISH<br>Refrig = R410A | <b>SET UNIT SPs (9)</b><br>Units = °F/psi<br>Lang = ENGLISH<br>Refrig = R134a |
|---|---|

Refrigerant type is factory-set.

|   |
|---|
| <b>SET UNIT SPs (10)</b><br>Protocol = Modbus<br>Ident Number=001<br>Baud Rate=9600 |
|---|

BAS interface settings, available mid-2003.

|   |
|---|
| <b>SET UNIT SPs (11)</b><br>Evap Press Sensor<br>Cir 1 Offset XX.X psi<br>Cir 2 Offset XX.X psi |
|---|

The pressure offsets on menus 11 and 12 and the temperature offsets on menus 10, 11 and 12 correct the controller's display of the parameters. The sensors used in these units have a high degree of repeatability but may need correction (offset). An accurate pressure gauge or thermometer is used to determine the correct temperature or pressure. A positive or negative offset value is then entered to make the controller reading agree with the measured value.

|   |
|---|
| <b>SET UNIT SPs (12)</b><br>Cond Press Sensor<br>Cir 1 Offset XX.X psi<br>Cir 2 Offset XX.X psi |
|---|

|   |
|---|
| <b>SET UNIT SPs (13)</b><br>Evap Leaving Water<br>Temperature Sensor<br>Offset= 00.0 °F |
|---|

|   |
|---|
| <b>SET UNIT SPs (13)</b><br>LWT Sensors<br>Evap Offset = 00.0 °F<br>Cond Offset = 00.0 °F |
|---|

**TGZ Units (Refrig = R134a)**

|   |
|---|
| <b>SET UNIT SPs (14)</b><br>OAT/Cond Lvg Water<br>Temperature Sensor<br>Offset= 00.0 °F |
|---|

|   |
|---|
| <b>SET UNIT SPs (14)</b><br>LWT Sensors<br>Evap Offset = 00.0 °F<br>Cond Offset = 00.0 °F |
|---|

|   |
|---|
| <b>SET UNIT SPs (15)</b><br>Suction Temp Sensor<br>Cir1 Offset 00.0 °F<br>Cir2 Offset 00.0 °F |
|---|

**WGZ Unit (R407C,R410A)**

|   |
|---|
| <b>SET UNIT SPs (16)</b><br>Clg ResType = X<br>Clg MaxRes = XX.X °F |
|---|

**TGZ Unit (Refrig = 134a)**

|  |
|--|
| <b>SET UNIT SPs (16)</b><br>Liq Line Temp Sensors<br>Circl1 Offset = 00.0 °F<br>Circ2 Offset = 00.0 °F |
|--|

### WGZ Unit (R407C,R410A)

```
SET UNIT SPs      (17)
ENTER PASSWORD: XXXX
Active Password
Level: None
```

### TGZ Unit (Refrig = 134a)

```
SET UNIT SPs      (17)
Clg ResType = X
Clg MaxRes = XX.X °F
Clg StrtRes = XX.X °F
```

### TGZ Unit in CoolingMode .

```
SET UNIT SPs      (17)
ENTER PASSWORD: XXXX
Active Password
Level: None
```

### TGZ Unit in Heat Mode.

```
SET UNIT SPs      (17)
Htg ResType = X
Htg MaxRes = XX.X °F
Htg StrtRes = XX.X °F
```

### TGZ Unit Heat Mode.

```
SET UNIT SPs      (18)
ENTER PASSWORD: XXXX
Active Password
Level: None
```

Two four-digit passwords provide OPERATOR and MANAGER levels of access to changeable parameters. The passwords are preprogrammed into the controller. Either password must be entered using the ENTER PASSWORD (12) screen before a protected setting can be changed. The operator password is 0100. The manager level is 2001.

This screen can be accessed either through the SET OTHER menu or by simply pressing the ENTER key while on one of the SET screens. The controller will automatically go from the screen with the setting change to this screen. After the correct password has been entered, the controller will automatically return to the original set screen.

Once a password has been entered, it remains valid for 15 minutes after the last key-press.

### Set Compressor Setpoints

```
SET COMP SPs      (1)
# of Compressors = X
Stop-Start =XXmin
Start-Start =XXmin
```

This menu sets the anti-recycle timers. Stop-Start is the time required before starting a compressor after it has *stopped*. Start-Start is the time required before starting a compressor after the last time it has *started*. It is recommended that the default values of 5 minutes and 15 minutes not be changed.

```
SET COMP SPs      (2)
InterStgUp =XXXsec
InterStgDown= XXsec
Clear Cycle Tmr = NO
```

InterStageUp is the time delay since the last stage change before a compressor can stage on, default is 120 sec.

InterStageDn is the time delay since the last stage change before a compressor can stage off normally (not by an alarm). Default is 30 sec. It is recommended that these settings not be changed.

# of Compressors = 4

```
SET COMP SPs (3)
Comp 1 = Enable
Comp 3 = Enable
```

# of Compressors = 6

```
SET COMP SPs (3)
Comp 1 = Enable
Comp 3 = Enable
Comp 5 = Enable
```

# of Compressors = 4

```
SET COMP SPs (4)
Comp 2 = Enable
Comp 4 = Enable
```

# of Compressors = 6

```
SET COMP SPs (4)
Comp 2 = Enable
Comp 4 = Enable
Comp 6 = Enable
```

Enable screens #3 and #4 require the manager password to change.

**TGZ Units Only (R134a)**

```
SET COMP SPs (5)
Expansion Valve
Type = Thermal
```

```
SET COMP SPs (5)
Expansion Valve
Type = Electronic
MaxOpPress=XXX.X psi
```

**Expansion Valve Type = Electronic**

```
SET COMP SPs (6)
Cir 1 EXV
EXV Control = Auto
Manual EXV Pos=XXX.X
```

**Expansion Valve Type = Electronic**

```
SET COMP SPs (7)
Cir 2 EXV
EXV Control = Auto
Manual EXV Pos=XXX.X
```

**Expansion Valve Type = Electronic Only**

```
SET COMP SPs (8)
SuperheatTarg= XX.X
```

### SET ALARM LIMITS

```
SET ALARM LMTS (1)
Low EVAP Pressure
Hold=XXXpsi
Unload=XXXpsi
```

The Hold and Unload have the same default value of 59 psi. If two compressors are running, the LowEvPrUnld is in effect and the lag compressor will be shut off to unload the unit. If one compressor is running, the LowEvPrHold is in effect and the lag compressor is prevented from starting, thereby holding the unit capacity.



The last action to take place is the shutoff of all compressors running when the LowEvPrStop setting is reached (default is 58 psi). Reducing these time intervals will increase detrimental compressor cycling. It is recommended that these settings not be changed.

```
SET ALARM LMTS (2)
High Cond Pressure
  Unload= XX.X°F
  Stop=XXXsec
```

Unload is a limit alarm that unloads the unit at 370 psi in an attempt to prevent total shutdown from the HighCondPr at 380 psi. The stage down is set at 370 psi. It is recommended that these settings not be changed.

Stop (the unit high-discharge-pressure shutdown) is a stop alarm that shuts off the unit when the discharge pressure reaches the setting. The default setting is 380 psi.

LowEvPrDelay is a time delay on the low pressure trip that reduces nuisance low-pressure trips. The default setting is 30 seconds.

```
SET ALARM LMTS (3)
GroundFault = N
PhaseVoltage = N
Low OATstartTMR=XXsec
```

GroundFault and PhaseVoltage entries are Y (Yes) or N (No) depending on whether the options are on the unit.

CondFreeze is an alarm that reduces the chance of freezing the water in the condenser (when compressors are not running). An alarm is registered and the condenser pump is energized at the same time. The alarm setpoint is 34°F saturated condenser temperature and it resets at +2°F above the setpoint.

```
SET ALARM LMTS (4)
Evap Freeze = XX.X°F
EvapFlowProff=XXXsec
Recirc Timeout=XXmin
```

Evap Freeze (the unit freeze protection shutdown) is actually a stop alarm and shuts off the unit when the LWT reaches 36°F. It is cleared by going to the CLEAR ALARM menu in the ACTIVE ALARM hierarchy.

EvapFlowProof is the flow switch interlock. Closing the flow switch and therefore proving the existence of chilled water flow resets this trip. It is recommended that these settings not be changed.

LowAmbientLock applies to units with air-cooled condensers and prevents unit operation below the setting. The available range is -2°F to 60°F with a default of 35°F.

**WaterCooled=ON**

```
SET ALARM LIMITS (5)
Cond Freeze= XX.X °F
CondFlowProof= XX sec
```

**TGZ in Heat Mode**

```
SET ALARM LIMITS (6)
LowSourceTmp = XX.X°F
LowSourceDif = XX.X°F
```

## Set Air-Cooled Condenser Fans

Water-cooled = Off

|                  |     |
|------------------|-----|
| SET FANS SPs     | (1) |
| Fan Stages=X     |     |
| Speedtrol=Yes/No |     |

Water-cooled = Off

|                        |      |      |
|------------------------|------|------|
| SET FANS SPs           | (2)  |      |
| Stage ON Deadband (°F) |      |      |
| Stg2                   | Stg3 | Stg4 |
| XXX                    | XXX  | XXX  |

Water-cooled = Off

|                         |      |      |
|-------------------------|------|------|
| SET FANS SPs            | (3)  |      |
| Stage Off Deadband (°F) |      |      |
| Stg2                    | Stg3 | Stg4 |
| XXX                     | XXX  | XXX  |

The SET FANS SP screens 2 through 5 establish the temperature that will stage the condenser fans on and off. These screens apply only to units set up for use with air-cooled condensers (WaterCooled=No). On such units, the settings do not have to be entered if the unit controller is not used to stage condenser fans for head pressure control. If the MicroTech II unit controller is not used to control the fans, some other method must be used.

Water cooled=Off

|                      |     |
|----------------------|-----|
| SET FANS SPs         | (4) |
| Cond Sat Temp Target |     |
| Set Point= XXX.X °F  |     |

Water cooled=Off

|                      |       |        |
|----------------------|-------|--------|
| SET FANS SPs         | (5)   |        |
| # Fans On At Startup |       |        |
| >75°F                | >90°F | >105°F |
| X                    | X     | X      |

## Set Cooling Tower Control

The MicroTech II controller is capable of controlling cooling tower water temperature on chillers using water-cooled condensers. Output wiring connection points are shown on the field wiring diagrams.

[Water Cooled = Y] - Condenser Pump on with first Compressor on. Tower fan control is active when the Tower Control setpoint is set to Temperature and the condenser pump is in the RUN state. Staging is based on Entering Condenser Water Temperature (ECWT). Operation depends on the following.

Condenser pump state

ECWT OR Lift pressure

Stage up and stage down timer values

Tower setpoints (Tower Control, Tower Stages, Stage Up Time, Stage Down Time, Stage Differential, Stage #1 ON, Stage #2 ON, Stage Down @, Stage Up @)

When the condenser pump starts, the stage up timer shall start. The first stage shall turn ON when the following conditions are met:

The stage up timer completes

The ECWT is > Stage #1 ON setpoint

Bypass valve position is > the Stage Up @ setpoint (only if Valve/VFD Control setpoint = Valve Stage)  
Additional stages can turn on (up to the number specified by the Tower Stages setpoint) when above conditions are met for the next stage plus the following condition:  
VFD Speed is > the Stage Up @ setpoint (only if Valve/VFD Control setpoint = VFD Stage OR Valve SP/VFD Stage)

Down staging shall occur when the following conditions are met:

The stage down timer completes

The ECWT is < Stage #X ON (Temp) setpoint – Stage Differential (Temp) setpoint

Bypass valve position is < the Stage Down @ setpoint (only if Valve/VFD Control setpoint = Valve Stage)

VFD Speed is < the Stage Down @ setpoint (only if Valve/VFD Control setpoint = VFD Stage OR Valve SP/VFD Stage)

Each stage up or stage down event shall restart both the stage up and stage down timers. Only one fan output shall be switched at a time (except that all outputs switch OFF when the condenser pump state equals OFF).

### Water-cooled On

```
SET TOWER SPs (1)
Tower Control= None
Tower Stages = X
StageUP/DN=XXX/XXX%
```

When Tower Control is None the control of condenser water temperature is not by the MicroTech II controller and assumed to be furnished elsewhere.

Tower Stages is the number of tower fans to be staged by the controller, choices are 0, 1, or 2. "0" indicates control will be by a bypass valve or variable speed pump controlled by the MicroTech II controller.

StageUP/DN imposes a time delay between fan stages when turning on or turning off.

### Water-cooled On

```
SET TOWER SPs (2)
Stage ON (Temp)°F
#1 #2
XXX XXX
```

Stage ON Temp is the entering condenser water temperature (ECWT) that will turn on tower fan #1 and #2. Default settings are 70°F and 75°F. Cold condenser water will improve unit efficiency but too cold can cause erratic operation. Settings below 60°F are not recommended.

### Water-cooled On

```
SET TOWER SPs (3)
StageDiff = XX.X°F
Stage Up Tmr=XX min
StageDn Tmr=XX min
```

StageDiff is the number of degrees below the Stage ON that will turn off the tower fans. For example, if Stage ON #1 is 70°F and StageDiff is 5°F, tower fan #1 will stage off when the ECWT drops to 65°F and stage the fan on when the ECWT rises to 70°F. The same is true for fan #2.

Stage Up timer is the number of minutes that must elapse between the condenser pump starting (it starts with the unit) and fan #1 starting or the time between fan #1 starting and fan #2 starting.

StageDown is the elapsed time between staging down the fan motors.

## Water-cooled = Y

|   |
|---|
| <b>SET TOWER SPs (4)</b><br><b>Valve/VFD Control=</b><br><b>ValveSP/VFDStage</b><br><b>Valve Type=NC to Twr</b> |
|---|

Valve/VFD Control settings are None, Valve Setpoint, Valve Stage, VFD Stage, or ValveSP/VFDStage. Default is None which results in no control of the tower from the MicroTech II controller.

Valve Setpoint, the valve will control (bypass tower) to hold the minimum temperature as established by the Set Tower SPs in screen (5) below.

This mode is operational when the Valve/VFD Control setpoint is set to Valve Setpoint OR Valve SP/VFD Stage. In this mode the valve output is varied with a proportional-derivative (PD) algorithm (with deadband) in order to maintain the controlled parameter (CP) at the desired value. The output is always limited between the Valve Control Range (Min) setpoint and the Valve Control Range (Max) setpoint. A valve increment shall be computed once every 5 seconds according to the following equation. (Error Gain and Slope Gain are set in menu screen #8.)

$$\text{Increment} = [(\text{Error}) * (\text{Error Gain setpoint})] + [(\text{Slope}) * (\text{Slope Gain setpoint})]$$

Where: Error = ECWT – Valve Setpoint

$$\text{Slope} = (\text{Present CP}) - (\text{Previous CP})$$

When the Error is > the Valve Deadband setpoint, the valve position analog output (% of full scale) is updated according to the following equation.

$$\text{New \%Position} = \text{Old \%Position} + \text{Increment}/10$$

Valve Stage, controls from the fan stage setpoint in use. It is recommended that the Valve Setpoint method explained above be used rather than this mode.

This mode is only operational when the Valve/VFD Control setpoint is set to Valve Stage. In this mode the valve output is controlled as for Valve Setpoint mode (above), except that the active setpoint for the controlled parameter is selected according to the following table.

| # Of Fans ON | Active Setpoint |
|--------------|-----------------|
| 0            | Valve Setpoint  |
| 1            | Stage #1 ON     |
| 2            | Stage #2 ON     |
| 3            | Stage #3 ON     |
| 4            | Stage #4 ON     |

VFD Stage, ValveSP/VFDStage, When the Valve/VFD Control setpoint is set to None, Valve Setpoint, OR Valve Stage, this output is set to 0. Otherwise, it will be controlled in a manner identical to Valve Stage Mode (above) except that (1) it shall be kept at zero until the first fan stage is ON, and (2) the following setpoints do not apply.

Valve Control Range (Min)

Valve Control Range (Max)

Valve Type

Valve Type settings are NC (normally closed to tower) or NO (normally open).

These settings establish the operation of a tower bypass valve (must be a 3-way valve).

### Initial Valve Position

When the condenser pump is not in the RUN state, the valve output shall be set as a function of entering condenser water temperature (ECWT) per the following graph.

**Figure 11, Initial Valve Position**

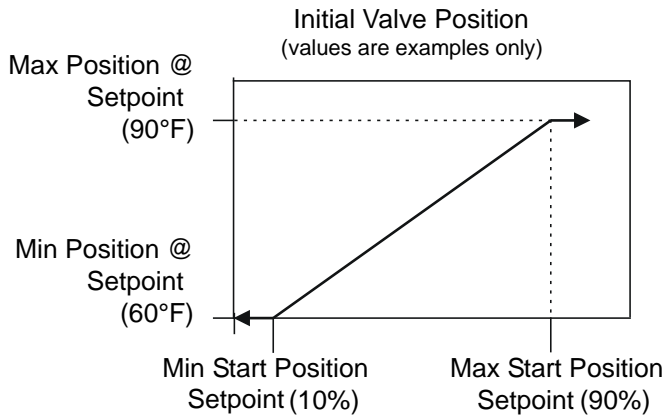

### Operation After Start

When the condenser pump is in the RUN state, the valve output shall be controlled in one of two modes as specified by the Valve/VFD Control setpoint. The controlled parameter shall be the condenser entering water temperature. When the desired output signal varies from 0 to 100%, the output voltage shall vary as shown below.

0 to 10 VDC (Valve Type = NC)

10 to 0 VDC (Valve Type = NO)

**Water-cooled = Y**

```
SET TOWER SPs (5)
Valve SP = XXX °F
Valve DB = XX.X °F
```

Valve SP is the minimum tower water temperature acceptable, default is 65°F.

Valve DB is the dead-band in degrees, default is 2.0°F.

**Water-cooled = Y**

```
SET TOWER SPs (6)
ValveStartPosition
  Min = XXX% @XXX°F
  Max = XXX% @XXX°F
```

The ValveStartPosition is the position of the valve when the unit starts. Default for minimum start position is 0%, and 100% for maximum position.

**Water-cooled = Y**

```
SET TOWER SPs (7)
Valve Control Range
  Min = XXX%
  Max = XXX%
```

Defaults are 10% minimum and 90% maximum.

**Water-cooled = Y**

```
SET TOWER SPs (8)
PD Control Loop
  Error Gain = XX
  Slope Gain = XX
```

Defaults are 25 for both error and slope.

## TEST

The test screens are only available when the unit is in TEST mode. Using these screens, any digital output can be controlled manually.

### R407C

```
TEST UNIT          (1)
Alarm Signal =OFF
Evap Pump 1 = OFF
```

### # of Compressors = 4

```
TEST UNIT          (2)
Liq Line Sol #1= OFF
CompressorHG1 = OFF
1= OFF  3= OFF
```

### # of Compressors = 4

```
TEST UNIT          (3)
Liq Line Sol #2=OFF
Compressor HG2 = OFF
2= OFF  4= OFF
```

### Water Cooled = ON

```
TEST UNIT          (4)
Cond Pump 1 = OFF
Cond Pump 2 = OFF
TwrFan1=OFF Fan2=OFF
```

### Water Cooled = ON

```
TEST UNIT          (5)
Twr Bypass= XXX.X %
Twr VFD=      XXX.X %
```

```
TEST UNIT          (6)
EXV Cir 1= XXX.X %
EXV Cir 2= XXX.X %
```

### R410A

```
TEST UNIT          (1)
Alarm Signal =OFF
Evap Pump 1 = OFF
Evap Pump 2 = OFF
```

### # of Compressors = 6

```
TEST UNIT          (1)
Liq Line Sol #1= OFF
Compressor HG1 = OFF
1= OFF  3= OFF  5= OFF
```

### # of Compressors = 6

```
TEST UNIT          (3)
Liq Line Sol #2=OFF
Compressor HG2 = OFF
2= OFF  4= OFF  6= OFF
```

### Water Cooled = OFF

```
TEST UNIT          (4)
Fan 1=OFF  Fan 3=OFF
Fan 5/7=OFF
Fan 9=OFF
```

### Water Cooled = OFF

```
TEST UNIT          (5)
Fan 2=OFF  Fan 4=OFF
Fan 6/8=OFF
Fan 10=OFF
```

## Editing Review

Editing shall be accomplished by pressing the ENTER key until the desired field is selected. This field shall be indicated by a blinking cursor under it. The arrow keys shall then operate as defined below.

CANCEL (Right) Reset the current field to the value it had when editing began.

DEFAULT (Left) Set value to original factory setting.

INCREMENT (Up) Increase the value or select the next item in a list.

DECREMENT (Down) Decrease the value or select the previous item in a list.

During edit mode, the display shall show a two-character wide menu pane on the right as shown below.

|                  |    |
|------------------|----|
| SET UNIT SPs (X) | <D |
| (data)           | <C |
| (data)           | <+ |
| (data)           | <- |

Additional fields can be edited by pressing the ENTER key until the desired field is selected. When the last field is selected, pressing the ENTER key switches the display out of “edit” mode and returns the arrow keys to “scroll” mode.

### Alarms

When an alarm occurs, the alarm type, limit value (if any), date, and time are stored in the active alarm buffer corresponding to that alarm (viewed on the Alarm Active screens) and also in the alarm history buffer (viewed on the Alarm Log screens). The active alarm buffers hold a record of the last occurrence of each alarm and whether or not it has been cleared. The alarm can be cleared by pressing the Edit key. A separate buffer is available for each alarm (High Cond Pressure, Evaporator Freeze Protect, etc.). The alarm history buffer holds a chronological account of the last 25 alarms of any type.

### Security

Two four-digit passwords provide OPERATOR and MANAGER levels of access to changeable parameters. Either password can be entered using the ENTER PASSWORD screen which can be accessed either through the SET OTHER menu or by simply pressing the ENTER key while on one of the SET screens. The password can then be entered by pressing the ENTER key, scrolling to the correct value with the UP and DOWN arrow keys, and pressing ENTER again. Once the correct password has been entered, the previously selected screen will reappear. Once a password has been entered, it will remain valid for 15 minutes after the last key-press.

# BAS Interface

The BAS interface will use the supervisor port on the controller as a connection point.

## Protocols Supported

The following building automation system (BAS) protocols are supported. It is possible to change the building automation interface without loading different software.

### BACnet®

When protocol is set to BACnet, the baud rate and ident set points are not accessible. The ident setting is locked at 1 for BACnet, and the baud rate is locked to 19200.

### LONworks®

With protocol set to LON, the baud rate and ident set points are not accessible. The ident setting is locked at 1 for LON, and the baud rate is locked to 4800.

### Modbus®

With the protocol set to Modbus, the baud rate and ident set points are accessible.

## Available Parameters

Types: A = Analog, I= Integer, D= Digital

I/O: I = Input only, O = Output only , I/O = Input/Output

| Type | Index | I/O | Description                        | LONWORKS | BACnet | Modbus |
|------|-------|-----|------------------------------------|----------|--------|--------|
| A    | 1     | I/O | Network Cool LWT set point         | x        | x      | x      |
| A    | 2     | O   | Active LWT set point               | x        | x      | x      |
| A    | 3     | I/O | Network limit set point            | x        | x      | x      |
| A    | 6     | O   | Evap LWT                           | x        | x      | x      |
| A    | 7     | O   | Cond EWT                           | x        | x      | x      |
| A    | 10    | O   | Unit capacity (%)                  | x        | x      | x      |
| A    | 11    | I   | Network Cool LWT set point default | x        |        |        |
| A    | 15    | O   | Suction temp                       | x        | x      | x      |
| A    | 16    | O   | Evap sat temp                      | x        | x      | x      |
| A    | 17    | O   | Evap pressure                      | x        | x      | x      |
| A    | 20    | O   | Cond sat temp                      | x        | x      | x      |
| A    | 21    | O   | Cond pressure                      | x        | x      | x      |
| A    | 39    | O   | OAT                                | x        | x      | x      |
| A    | 42    | O   | Active Capacity Limit              | x        | x      | x      |
| A    | 50    | I/O | Network Ice LWT set point          | x        | x      | x      |
|      |       |     |                                    |          |        |        |
| I    | 1     | O   | Active alarms 1                    | x        | x      | x      |
| I    | 2     | O   | Active alarms 2                    | x        | x      | x      |
| I    | 3     | O   | Active alarms 3                    | x        | x      | x      |
| I    | 4     | O   | Active alarms 4                    | x        | x      | x      |
| I    | 5     | O   | Active alarms 5                    | x        | x      | x      |
| I    | 6     | O   | Active alarms 6                    | x        | x      | x      |
| I    | 7     | O   | Active alarms 7                    | x        | x      | x      |
| I    | 8     | O   | Active alarms 8                    | x        | x      | x      |
| I    | 9     | O   | Active alarms 9                    | x        | x      | x      |
| I    | 10    | O   | Active alarms 10                   | x        | x      | x      |

Continued next page.



**Table continued**

| Type | Index | I/O | Description  | LONworks | BACnet | Modbus |
|------|-------|-----|--|----------|--------|--------|
| I    | 11    | O   | Active alarms 11   | x        | x      | x      |
| I    | 12    | O   | Active alarms 12   | x        | x      | x      |
| I    | 13    | O   | Active alarms 13   | x        | x      | x      |
| I    | 14    | O   | Active alarms 14   | x        | x      | x      |
| I    | 15    | O   | Active alarms 15   | x        | x      | x      |
| I    | 16    | O   | Active alarms 16   | x        | x      | x      |
| I    | 17    | I   | Network chiller mode set point   | x        | x      | x      |
| I    | 18    | O   | LON Chiller run mode   | x        |        | x      |
| I    | 19    | O   | Active chiller mode  | x        | x      | x      |
| I    | 20    | I   | Network demand limit default set point   | x        |        |        |
| I    | 21    | I   | Network chiller mode default set point   | x        |        |        |
| I    | 22    | O   | Sequence Status<br>Bit 1 – Unit Full Load Flag<br>Bit 2 – Circuit One Available Flag<br>Bit 3 – Circuit Two Available Flag | x        | x      | x      |
| I    | 28    | O   | Unit model type, refrigerant   | x        | x      | x      |
| I    | 29    | O   | Unit language  | x        | x      | x      |
| I    | 30    | O   | Unit software version  | x        | x      | x      |
| I    | 32    | I   | Compressor select  | x        | x      | x      |
| I    | 35    | I/O | Clock year   |          | x      | x      |
| I    | 36    | I/O | Clock month  |          | x      | x      |
| I    | 37    | I/O | Clock day of month   |          | x      | x      |
| I    | 38    | I/O | Clock day of week  |          | x      | x      |
| I    | 39    | I/O | Clock hours  |          | x      | x      |
| I    | 40    | I/O | Clock minutes  |          | x      | x      |
| I    | 45    | O   | Compressor starts  |          | x      | x      |
| I    | 46    | O   | Compressor run hours   |          | x      | x      |
| D    | 1     | I/O | Network chiller enable set point   | x        | x      | x      |
| D    | 2     | O   | Chiller enable status  | x        | x      | x      |
| D    | 3     | O   | Active alarm indicator   | x        | x      | x      |
| D    | 4     | O   | Chiller run enabled  | x        | x      | x      |
| D    | 5     | O   | Chiller local control  | x        | x      | x      |
| D    | 6     | O   | Chiller capacity limited   | x        | x      | x      |
| D    | 7     | O   | Evap flow  | x        | x      | x      |
| D    | 8     | O   | Cond flow  | x        | x      | x      |
| D    | 9     | I   | Network chiller enable default set point   | x        |        |        |
| D    | 10    | I   | Ignore network defaults  | x        |        |        |
| D    | 24    | I   | Network clear alarm signal   | x        | x      | x      |

## Parameter Details

### Units of Measure

Parameters will be expressed in different units dependant on the protocol selected.

| Parameter Type | Modbus Units | BACnet Units | LONworks Units |
|----------------|--------------|--------------|----------------|
| Temperature    | °F X 10      | °F X 10      | °C X 100       |
| Pressure       | PSI X 10     | PSI X 10     | KPa X 10       |
| Percentage     | % X 10       | % X 10       | % X 200        |

## Chiller Mode

Applies to Integer 17 and Integer 19. Network Chiller Mode Set Point and Active Chiller Mode use the same numbering scheme to represent ice mode or cool mode. The output representing the mode is shown below for each protocol.

| Mode | LONworks | BACnet | Modbus |
|------|----------|--------|--------|
| Heat | 1        | 3      | 3      |
| Cool | 3        | 2      | 2      |
| Ice  | 11       | 1      | 1      |

Any time the chiller is not in Ice mode, Cool mode will be assumed.

## LON Chiller Run Mode

Applies to Integer 18. The LON Chiller Run Mode parameter indicates the unit state as follows:

| State   | LONworks | BACnet | Modbus |
|---------|----------|--------|--------|
| Off     | 0        | 1      | 1      |
| Run     | 2        | 3      | 3      |
| Service | 4        | 5      | 5      |

State = Off any time the state is not Run or Service

State = Run when the unit state is Auto

State = Service when the unit is in Test mode

## Unit Identification

Integer 28 indicates the unit model type and refrigerant. For the WGZD with R-22, R407c, R410A and TGZ with R134a, the refrigerant the output is 3.

Integer 29 indicates the unit language. For the WGZD the language can only be English, so output is 1.

Integer 30 indicates the software version and revision. The hundreds digit represents the version, and the remaining part represents the revision letter.

## Compressor Select

Compressor Select is used to select the compressor for which the associated parameters will be sent to the BAS interface. The input should equal the number of the compressors for which data is desired. If a 0 is sent from the BAS, this will also select compressor 1.

## Timeclock Setting

The chiller time and date may be changed through the BAS interface. Time and date are updated by first setting the values for the time and date inputs on the BAS. When the BAS sets digital index 12 high, the time and date in the controller is set to the values supplied by the BAS. The values used are as follows:

Year: Integer # 35 (00 to 99)

Month: Integer # 36 (1 to 12)

Day of Month: Integer # 37 (1 to 31)

Day of Week: Integer # 38 (1 to 7)

Hour: Integer # 39 (0 to 23)

Minute: Integer # 40 (0 to 59)

## Network Defaults

The network set point default values are used only for the LONworks protocol. Digital index 10 determines whether the network defaults should be loaded at startup. The startup process is as follows.

Immediately after the controller powers up, the protocol is checked. If the protocol is LONworks, then the current status of the BAS unit enable set point, digital 1, is stored in a temporary location and the BAS enabled set point is set to disable. A ten second timer should lapse, then the “ignore network defaults”

setting is checked. If this is set low, then the defaults for BAS cool set point, network limit, unit enable, and unit mode will be loaded. If the setting is set high, then no defaults are loaded and the status of the BAS enable set point is restored to the original value.

### Other Digital Output Parameters

| Type | Index | I/O | Description              | Details   |
|------|-------|-----|--------------------------|---|
| D    | 2     | O   | Chiller enable status    | Set whenever the chiller is enabled by all settings and switches  |
| D    | 3     | O   | Active alarm indicator   | Set when any alarm is active. Active events do not set this output  |
| D    | 4     | O   | Chiller run enabled      | Set when the unit state is auto   |
| D    | 5     | O   | Chiller local control    | Set when the unit control source is set to keypad or switches.  |
| D    | 6     | O   | Chiller capacity limited | Set when a unit capacity limit is active, any circuit is disabled, or any circuit is limited in capacity. |
| D    | 7     | O   | Evap flow                | Set when evap flow switch is closed   |
| D    | 8     | O   | Cond flow                | Set when cond flow switch is closed and watercooled = yes.  |

More information on the BAS installation and operation can be found in the following manuals shipped with the unit and also available on [www.DaikinApplied.com](http://www.DaikinApplied.com):

|                       |          |
|-----------------------|----------|
| LonWorks              | IM 735-2 |
| Modbus                | IM 743-3 |
| BACnet Ethernet or IP | IM 837   |
| BACnet (MS/TP)        | IM 906   |

# Compressor Motor protection Module

The 20, 26, and 30 HP compressors are equipped with an module that provides protection against:

- High motor temperature
- High scroll temperature
- Phase missing
- Phase reversal
- Low control circuit voltage

The module also has a LED display in the upper right-hand corner that gives information on compressor operation.

The module is accessible by removing the compressor motor cover. Additional information can be downloaded by authorized service technicians using special equipment.

**NOTE:** If a compressor with CoreSense Communications fails in the field, the CoreSense module should remain with the failed compressor so the manufacturer can download the CoreSense data to assist with determining the root cause of compressor failure.



## ⚠ Warning

Disconnect the compressor three-phase power before removing the terminal box cover. Removal of the terminal box cover will expose the three-phase power connections. Contact with them can cause serious injury or death. Servicing should be done by technicians familiar with this equipment.

### Warning Codes (Green LED Flash Code)

- Code 1 – Loss of Communication: The module will flash the green **Warning** LED one time indicating the module has not communicated with the master controller for longer than 5 minutes. Once communication is reinitiated, the **Warning** will be cleared.
- Code 2 – Reserved For Future Use
- Code 3 – Short Cycling: The module will flash the green **Warning** LED three times indicating the compressor has short cycled more than 48 times in 24 hours. A short cycle is defined as compressor runtime of less than 1 minute. The **Warning** will be activated when the “Short Cycling” dipswitch (#10) is “off” or in the “down” position. When fewer than 48 short cycles are accumulated in 24 hours the **Warning** code will be cleared.
- Code 4 – Open/Shorted Scroll Thermistor. The module will flash the green **Warning** LED four times indicating the scroll NTC thermistor has a resistance value that indicates an open/shorted thermistor (see **Table 2**). The **Warning** will be cleared when the resistance value is in the normal range.

### Alert/Lockout Codes (Red LED Flash Code)

Code 1 – Motor High Temperature: The module will flash the red **Alert** LED one time indicating the motor PTC circuit has exceeded 4.5K Ohms. A code 1 **Alert** will open the M2-M1 contacts. The **Alert** will reset after 30 minutes and the M2-M1 contacts will close if the resistance of the motor PTC circuit is below 2.75K Ohms. Five consecutive Code 1 **Alerts** will lockout the compressor. Once the module has locked out the compressor, a power cycle or Modbus reset command will be required for the lockout to be cleared.

Code 2 – Open/Shorted Motor Thermistor: The module will flash the red **Alert** LED two times indicating the motor PTC thermistor circuit has a resistance value that indicates an open/shorted thermistor chain (see **Table 2**). A Code 2 **Alert** will open the M2-M1 contacts. The **Alert** will reset after 30 minutes and the M2-M1 contacts will close if the resistance of the motor PTC circuit is back in the normal range. The module will lockout the compressor if the trip condition exists for

longer than 6 hours. Once the module has locked out the compressor, a power cycle or Modbus reset command will be required to clear the lockout.

Code 3 – Short Cycling: The module will flash the red **Alert** LED three times indicating the compressor is locked out due to short cycling. A Code 3 **Alert** will open the M2-M1 contacts. Code 3 will be enabled when the "Short Cycling" dipswitch (#10) is "on" or in the "up" position and the compressor has exceeded the number of short cycles configured by the user in a 24 hour period. Once the module has locked out the compressor, a power cycle or Modbus reset command will be required to clear the lockout.

Code 4 – Scroll High Temperature: The module will flash the red Alert LED four times indicating the scroll NTC circuit is less than 2.4K Ohms. A Code 4 Alert will open the M2-M1 contacts. The Alert will reset after 30 minutes and the M2-M1 contacts will close if the resistance of the scroll NTC circuit is higher than 5.1K Ohms. The module will lockout the compressor if the number of Code 4 Alerts exceeds the user configurable number of Code 4 events within a 24 hour period. Once the module has locked out the compressor, a power cycle or Modbus reset command will be required to clear the lockout.

Code 5 – Reserved for Future Use

Code 6 – Missing Phase: The module will flash the red Alert LED six times indicating a missing phase in one of the three leads to the compressor. A Code 6 Alert will open the M2-M1 contacts. The Alert will reset after 5 minutes and the M2-M1 contacts will close if the missing phase condition is not present. The module will lockout the compressor after 10 consecutive Code 6 Alerts. Once the module has locked out the compressor, a power cycle or Modbus reset command will be required to clear the lockout.

Code 7 – Reverse Phase: The module will flash the red Alert LED seven times indicating a reverse phase in two of the three leads to the compressor. A Code 7 Alert will open the M2-M1 contacts. The module will lockout the compressor after one Code 7 Alert. A power cycle or Modbus reset command will be required to clear the lockout.

Code 8 – Reserved For Future Use

Code 9 – Module Low Voltage

The module will flash the red Alert LED nine times indicating low module voltage (see Table 2) on the T2-T1 terminals for more than 5 seconds. A Code 9 Alert will open the M2-M1 contacts. The Alert will reset after 5 minutes and the M2-M1 contacts will close if the T2-T1 voltage is above the reset value

### **Resetting Alert Codes**

Resetting **Alert** codes can be accomplished in two different ways. First, **Alert** codes can be reset manually by cycling power to the module (disconnect T2 or T1 for 5 seconds). The second way to reset **Alert** codes is to send a Modbus reset command from the master controller. If the fault that initiated the **Alert** code is absent after one of the above resets is performed, the **Alert** code will be cleared and CoreSense will allow normal operation. If the fault is still present after the reset is performed the fault code will continue to be displayed via the green or red flashing LED.

# Optional Controls

---

## Phase/Voltage Monitor (Optional)

The phase/voltage monitor is a device that provides protection against three-phase electrical motor loss due to power failure conditions, phase loss, and phase reversal. Whenever any of these conditions occur, an input relay is deactivated, disconnecting power to the thermostatic control circuit. The compressor does a rapid shutdown including a pump down cycle.

The input relay remains deactivated until power line conditions return to an acceptable level. Trip and reset delays have been provided to prevent nuisance tripping due to rapid power fluctuations.

When three-phase power has been applied, the input relay should close and the “run light” should come on. If the relay does not close, perform the following tests.

1. Check the voltages between L1-L2, L1-L3, and L2-L3. These voltages should be approximately equal and within +10% of the rated three-phase line-to-line voltage.
2. If these voltages are extremely low or widely unbalanced, check the power system to determine the cause of the problem.
3. If the voltages are good, turn off the power and inter-change any two of the supply power leads at the disconnect switch.

This may be necessary, as the phase/voltage monitor is sensitive to phase reversal. Turn on the power. The relay should now close after the appropriate delay.

### Factory settings are as follows:

Voltage Setting, set at nameplate voltage.

Trip Delay Time, 2 seconds

Restart Delay Time, 60 seconds

## Hot Gas Bypass (Optional)

This option allows passage of discharge gas to the evaporator, permitting operation at lower loads than available with compressor unloading. It also keeps the velocity of refrigerant gas high enough for proper oil return at light load conditions.

The pressure regulating valve is a Sporlan SHGBE-8 and factory set to begin opening at 69 psig and can be changed by changing the pressure setting. The adjustment range is 0 to 100 psig. To raise the pressure setting, remove the cap on the bulb and turn the adjustment screw clockwise. To lower the setting, turn the screw counterclockwise. Do not force the adjustment beyond the range it is designed for, as this will damage the adjustment assembly. The regulating valve opening point can be determined by slowly reducing the system load while observing the suction pressure. When the bypass valve starts to open, the refrigerant line on the evaporator side of the valve will begin to feel warm to the touch.

### Warning

The hot gas line can become hot enough to cause personal injury in a very short time; care should be taken during valve checkout.

# System Maintenance

## General

To provide smooth operation at peak capacity and to avoid damage to package components, a program of periodic inspections should be set up and followed. The following items are intended as a guide to be used during inspection and must be combined with sound refrigeration and electrical practices to provide trouble-free performance.

The liquid line sight glass/moisture indicator on all circuits must be checked to be sure that the glass is full and clear and that the moisture indicator indicates a dry condition. If the indicator shows that a wet condition exists or if bubbles show in the glass, even with a full refrigerant charge, the filter-drier element must be changed.

Water supplies in some areas can tend to foul the water-cooled condenser to the point where cleaning is necessary. The fouled condenser will be indicated by an abnormally high condenser approach temperature (saturated discharge temperature minus leaving condenser water temperature) and can result in nuisance trip-outs. To clean the condenser, mechanical cleaning or a chemical descaling solution should be used according to the manufacturer's directions.

Remote air-cooled condensers require periodic cleaning of the finned surface of the condenser coil.

Cleaning can be accomplished by using a cold water spray, brushing, vacuuming, or high-pressure air. No tools should be used that could damage the coil tubes or fins.

The compressor oil level must be checked periodically to be sure that the level is at the center of the oil sightglass located in the compressor's equalizing line or on the compressor itself. Low oil level can cause inadequate lubrication and if oil must be added, use oils referred to in the following "Compressor Lubrication" section.

A pressure tap has been provided on the liquid line downstream of the filter-drier and solenoid valve but before the expansion valve. An accurate subcooled liquid pressure and temperature can be taken here. The pressure read here could also provide an indication of excessive pressure drop through the filter-drier and solenoid valve due to a clogging filter-drier. Note: A normal pressure drop through the solenoid valve is approximately 3 psig (20.7 kPa) at full load conditions.

### CAUTION

Warranty may be affected if wiring is not in accordance with specifications. Before replacing blown fuse or restarting compressor, the trouble must be found and corrected. It is important to have a qualified control panel electrician service this panel. Unqualified tampering with the controls can cause serious damage to equipment and void the warranty.

### DANGER

The panel is always energized to ground even when the system switch is off. To de-energize the complete panel including crankcase heaters, pull the main unit disconnect. Failure to do so can result in severe personal injury or death.

## Electrical Terminals

### WARNING

To avoid injury from electric shock hazard, turn off all power and perform lockout and tag-out of source before continuing with the following service. Note that the unit might be powered from multiple sources.

All power electrical terminals should be re-tightened every six months, as they tend to loosen due to normal heating and cooling of the wire.

## POE Lubrication

POE type oil is used for compressor lubrication. This type of oil is extremely hygroscopic, which means it will quickly absorb moisture if exposed to air and may form acids that can be harmful to the chiller. Avoid prolonged exposure of POE oil to the atmosphere to prevent this problem. For more details on acceptable oil types, contact your Daikin Applied service representative.

### CAUTION

POE oil must be handled carefully using proper protective equipment (gloves, eye protection, etc.) The oil must not come in contact with certain polymers (e.g. PVC), as it may absorb moisture from this material. Also, do not use oil or refrigerant additives in the system.

It is important that only the manufacturer's recommended oils be used. Acceptable POE oil types are:

- CPI/Lubrizol Emkarate RL32-3 MAF
- Exxon/Mobil EAL Arctic 22 CC\*
- Hatcol 22CC\*
- Everest 22CC\*
- Copeland Ultra 32-3 MAF
- Parker Emkarate RL32-3MAF
- Virginia LE323MAF
- Nu Calgon 4314-66

Note - \* These types of oils can only be used as "Top Off" oils. This is defined as adding less than 50% of the total amount of oil in the unit.

## Sightglass and Moisture Indicator

The refrigerant sight glasses should be observed periodically. A monthly observation should be adequate. A clear glass of liquid indicates that there is adequate refrigerant charge in the system to provide proper feed through the expansion valve. The sight glass should be clear when:

- Ambient temperature is above 75°F (23°C)
- Both compressors on a circuit are running
- All fans on a circuit are running

Bubbling refrigerant in the sight glass may occur at other conditions and *may* indicate that the system is short of refrigerant charge. Refrigerant gas flashing in the sight glass could also indicate an excessive pressure drop in the line, possibly due to a clogged filter-drier or a restriction elsewhere in the system. An element inside the sight glass indicates what moisture condition corresponds to a given element color. If the sight glass does not indicate a dry condition after about 12 hours of operation, the unit should be pumped down and the filter-driers changed.

If the system is suspected of being short of refrigerant, a qualified service technician with EPA certification should be contacted to thoroughly check out the unit and add refrigerant if necessary.

## Crankcase Heaters

The compressors are equipped with crankcase heaters. The function of the heater is to keep the temperature in the crankcase high enough to prevent refrigerant from migrating to the crankcase and condensing in the oil during off-cycle. When a system is to be started up initially, the power to the heaters should be turned on for at least 12 hours before the compressors are started. The crankcase should be up to about 80°F (26.7°C) before the system is started up, to minimize lubrication problems or liquid slugging of compressor on start-up.

If the crankcase is cool (below 80°F) (26.7°C) and the oil level in the sight glass is full to top, allow more time for oil to warm before starting the compressor. The crankcase heaters are on whenever power is supplied to the unit and the compressor is not running.



# Maintenance Schedule

|  | Monthly | Quarterly | Semi-Annually | Annually | As Required By Performance |
|--|---------|-----------|---------------|----------|----------------------------|
| <b>I. Compressor</b>                                       |         |           |               |          |                            |
| A. Performance Evaluation (Log & Analysis) *               | O       |           |               |          |                            |
| B. Motor   |         |           |               |          |                            |
| • Meg. Windings  |         |           | X             |          |                            |
| • Ampere Balance (within 10%)                              |         | X         |               |          |                            |
| • Terminal Check (tight connections, porcelain clean)      |         |           |               | X        |                            |
| • Motor Cooling (check temperature)                        |         | X         |               |          |                            |
| C. Lubrication System                                      |         |           |               |          |                            |
| • Oil Level  | O       |           |               | X        |                            |
| • Oil Appearance (clear color, quantity)                   | O       |           |               |          |                            |
| • Oil change if indicated by oil analysis                  |         |           |               |          | X                          |
| <b>II. Controls</b>  |         |           |               |          |                            |
| A. Operating Controls                                      |         |           |               |          |                            |
| • Check Settings and Operation                             |         |           | X             |          |                            |
| B. Protective Controls                                     |         |           |               |          |                            |
| • Test Operation of:                                       |         |           |               |          |                            |
| Alarm Relay  |         | X         |               |          |                            |
| Pump Interlocks  |         | X         |               |          |                            |
| High and Low Pressure Cutouts                              |         | X         |               |          |                            |
| <b>III. Condenser</b>                                      |         |           |               |          |                            |
| B. Test Water Quality                                      |         | X         |               |          |                            |
| C. Clean Condenser Tubes (or as required)                  |         |           |               | X        |                            |
| D. Eddycurrent Test - Tube Wall Thickness                  |         |           |               |          | X                          |
| E. Seasonal Protection                                     |         |           |               |          | X                          |
| <b>IV. Evaporator</b>                                      |         |           |               |          |                            |
| B. Test Water Quality                                      |         | X         |               |          |                            |
| C. Clean Evaporator Tubes (or as required)                 |         |           |               |          | X                          |
| D. Eddycurrent Test - Tube Wall thickness (or as required) |         |           |               |          | X                          |
| E. Seasonal Protection                                     |         |           |               |          | X                          |
| <b>V. Expansion Valves</b>                                 |         |           |               |          |                            |
| A. Performance Evaluation (Superheat Control)              |         | X         |               |          |                            |
| <b>VI. Compressor - Chiller Unit</b>                       |         |           |               |          |                            |
| A. Performance Evaluation                                  | O       |           |               |          |                            |
| B. Leak Test:  |         |           |               |          |                            |
| • Compressor Fittings and Terminal                         |         | X         |               |          |                            |
| • Piping Fittings  |         | X         |               |          |                            |
| • Vessel Relief Valves                                     |         | X         |               |          |                            |
| C. Vibration Isolation Test                                |         | X         |               |          |                            |
| D. General Appearance:                                     |         |           |               |          |                            |
| • Paint  |         |           |               | X        |                            |
| • Insulation   |         |           |               | X        |                            |
| <b>VII. Starter(s)</b>                                     |         |           |               |          |                            |
| A. Examine Contactors (hardware and operation)             |         | X         |               |          |                            |
| B. Verify Overload Setting and Trip                        |         | X         |               |          |                            |
| C. Test Electrical Connections                             |         | X         |               |          |                            |
| <b>VIII. Optional Controls</b>                             |         |           |               |          |                            |
| A. Hot Gas Bypass (verify operation)                       |         | X         |               |          |                            |

Key: O = Performed by in-house personnel      X = Performed by service personnel

# System Service

---

## DANGER

**Service on this equipment is to be performed only by qualified refrigeration personnel. Causes for repeated tripping of equipment protection controls must be investigated and corrected. Disconnect all power before doing any service inside the unit or serious personal injury or death can occur.**

---

NOTE: Anyone servicing this equipment must comply with the requirements set forth by the EPA concerning refrigerant reclamation and venting.

---

### **Filter-Driers**

To change the filter-drier, pump the unit down (with the compressor running) by closing the manual liquid line shutoff valve(s). The unit will start pumping down until it reaches the low-pressure cutoff setting of 58 psi.

Close the discharge valve. Remove the refrigerant in the liquid line with a recovery unit to EPA required pressure. Remove and replace the filter-drier(s). Evacuate the lines through the liquid line manual shutoff valve(s) to remove noncondensables that may have entered during filter replacement. A leak check is recommended before returning the unit to operation.

### **Liquid Line Solenoid Valve**

The liquid line solenoid valve(s), which are responsible for automatic pumpdown during normal unit operation, do not normally require any maintenance. However, in the event of failure they can require replacement of the solenoid coil or of the entire valve assembly.

The solenoid coil can be removed from the valve body without opening the refrigerant piping by moving pumpdown switch(es) PS1 and PS2 to the “manual” position.

The coil can then be removed from the valve body by simply removing a nut or snap-ring located at the top of the coil. The coil can then be slipped off its mounting stud for replacement. Be sure to replace the coil on its mounting stud before returning pumpdown switch(es) PS1 and PS2 to the “auto pumpdown” position.

To replace the entire solenoid valve, follow the steps for changing a filter-drier.

### **Thermostatic Expansion Valve**

The expansion valve is responsible for allowing the proper amount of refrigerant to enter the evaporator regardless of cooling load. It does this by maintaining a constant superheat. (Superheat is the difference between refrigerant temperature as it leaves the evaporator and the saturation temperature corresponding to the evaporator pressure). All WGZ chillers are factory set for between 8°F and 12°F (4.4°C to 6.7°C) superheat at full load.

To increase the superheat setting of the valve, remove the cap at the bottom of the valve to expose the adjustment screw. Turn the screw clockwise (when viewed from the adjustment screw end) to increase the superheat and counterclockwise to reduce superheat. Allow time for system rebalance after each superheat adjustment.

The expansion valve, like the solenoid valve, should not normally require replacement, but if it does, the unit must be pumped down by following the steps involved when changing a filter-drier.

If the problem can be traced to the power element only, it can be unscrewed from the valve body without removing the valve, but only after pumping the unit down.

**Table 8, Thermostatic Expansion Valve**

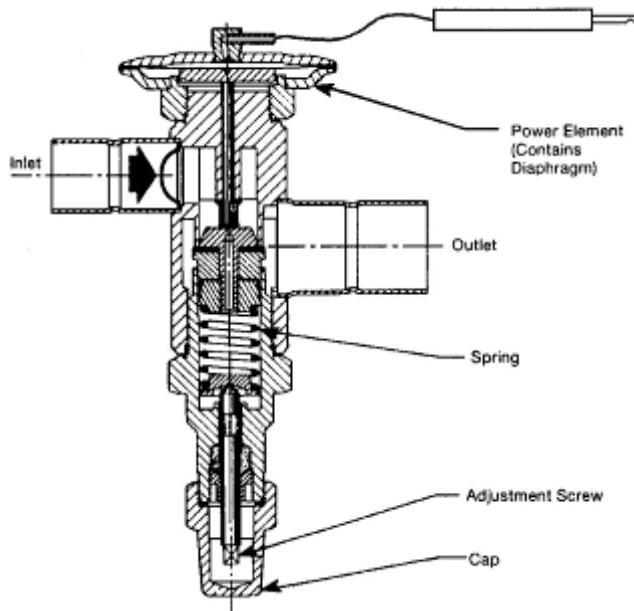

**⚠ CAUTION**

**Adjustment of expansion valve should only be performed by a qualified service technician. Failure to do so can result in improper unit operation.**

**Note:** Superheat will vary with compressor unloading, but should be approximately as follows: between 8°F and 12°F (4.4°C and 6.7°C) at full load; between 6°F and 10°F at part load.

**Water-cooled Condenser**

The condenser is of the shell-and-tube type with water flowing through the tubes and refrigerant in the shell. External finned copper tubes are rolled into steel tube sheets and to the center dividing tube sheet. Integral subcoolers are incorporated on all units. All condensers are equipped with 500 psig (3104 kPa) relief valves. Normal tube cleaning procedures can be followed.

**Evaporator**

The evaporator is a sealed, brazed-stainless steel plate unit. Normally no service work is required on the evaporator.

# Troubleshooting Chart

| PROBLEM                       | POSSIBLE CAUSES   | POSSIBLE CORRECTIVE STEPS   |
|-------------------------------|---|---|
| Compressor Will Not Run       | <ol style="list-style-type: none"> <li>1. Main switch, circuit breakers open.</li> <li>2. Fuse blown.</li> <li>3. Thermal overloads tripped or fuses blown.</li> <li>4. Defective contactor or coil.</li> <li>5. System shut down by equipment protection devices.</li> <li>6. No cooling required.</li> <li>7. Liquid line solenoid will not open.</li> <li>8. Motor electrical trouble.</li> <li>9. Loose wiring.</li> </ol>  | <ol style="list-style-type: none"> <li>1. Close switch</li> <li>2. Check electrical circuits and motor winding for shorts or grounds. Investigate for possible overloading. Replace fuse or reset breakers after fault is corrected.</li> <li>3. Overloads are auto reset. Check unit closely when unit comes back on line.</li> <li>4. Repair or replace.</li> <li>5. Determine type and cause of shutdown and correct it before resetting protection switch.</li> <li>6. None. Wait until unit calls for cooling.</li> <li>7. Repair or replace coil.</li> <li>8. Check motor for opens, short circuit, or burnout.</li> <li>9. Check all wire junctions. Tighten all terminal screws.</li> </ol> |
| Compressor Noisy or Vibrating | <ol style="list-style-type: none"> <li>1. Flooding of refrigerant into crankcase.</li> <li>2. Improper piping support on suction or liquid line.</li> <li>3. Worn compressor.</li> </ol>  | <ol style="list-style-type: none"> <li>5. Check superheat setting of expansion valve.</li> <li>6. Relocate, add or remove hangers.</li> <li>7. Replace.</li> </ol>  |
| High Discharge Pressure       | <ol style="list-style-type: none"> <li>15. Condenser water insufficient or temperature too high.</li> <li>16. Fouled condenser tubes (water-cooled condenser). Clogged spray nozzles (evaporative condenser). Dirty tube and fin surface (air cooled condenser).</li> <li>17. Noncondensables in system.</li> <li>18. System overcharge with refrigerant.</li> <li>19. Discharge shutoff valve partially closed.</li> <li>20. Condenser undersized (air-cooled).</li> <li>21. High ambient conditions.</li> </ol> | <ol style="list-style-type: none"> <li>17. Readjust temperature control or water regulating valve. Investigate ways to increase water supply.</li> <li>18. Clean.</li> <li>19. EPA purge the noncondensables.</li> <li>20. Remove excess refrigerant.</li> <li>21. Open valve.</li> <li>22. Check condenser rating tables against the operation.</li> <li>23. Check condenser rating tables against the operation.</li> </ol>   |
| Low Discharge Pressure        | <ol style="list-style-type: none"> <li>1. Faulty condenser temp. regulation.</li> <li>2. Insufficient refrigerant in system.</li> <li>3. Low suction pressure.</li> <li>4. Condenser too large.</li> <li>5. Low ambient conditions.</li> </ol>  | <ol style="list-style-type: none"> <li>1. Check condenser control operation.</li> <li>2. Check for leaks. Repair and add charge.</li> <li>3. See corrective steps for low suction pressure below.</li> <li>4. Check condenser rating table against the operation.</li> <li>5. Check condenser rating tables against the operation.</li> </ol>   |
| High Suction Pressure         | <ol style="list-style-type: none"> <li>1. Excessive load.</li> <li>2. Expansion valve overfeeding.</li> </ol>   | <ol style="list-style-type: none"> <li>1. Reduce load or add additional equipment.</li> <li>2. Check remote bulb. Regulate superheat.</li> </ol>  |
| Low Suction Pressure          | <ol style="list-style-type: none"> <li>1. Lack of refrigerant.</li> <li>2. Evaporator dirty.</li> <li>3. Clogged liquid line filter-drier.</li> <li>4. Clogged suction line or compressor suction gas strainers.</li> <li>5. Expansion valve malfunctioning.</li> <li>6. Condensing temperature too low.</li> <li>7. Compressor will not unload.</li> <li>8. Insufficient water flow.</li> </ol>  | <ol style="list-style-type: none"> <li>1. Check for leaks. Repair and add charge.</li> <li>2. Clean chemically.</li> <li>3. Replace cartridge(s).</li> <li>4. Clean strainers.</li> <li>5. Check and reset for proper superheat. Replace if necessary.</li> <li>6. Check means for regulating condensing temperature.</li> <li>7. See corrective steps for failure of compressor to unload.</li> <li>8. Adjust flow.</li> </ol>   |
| Little or No Oil Pressure     | <ol style="list-style-type: none"> <li>1. Clogged suction oil strainer.</li> <li>2. Excessive liquid in crankcase.</li> <li>3. Low oil level.</li> <li>4. Flooding of refrigerant into crankcase.</li> </ol>  | <ol style="list-style-type: none"> <li>1. Clean.</li> <li>2. Check crankcase heater. Reset expansion valve for higher superheat. Check liquid line solenoid valve operation.</li> <li>3. Add oil.</li> <li>4. Adjust thermal expansion valve.</li> </ol>  |

| <b>PROBLEM</b>                                 | <b>POSSIBLE CAUSES</b>  | <b>POSSIBLE CORRECTIVE STEPS</b>   |
|--|---|--|
| Compressor Loses Oil                           | <ul style="list-style-type: none"> <li>8. Lack of refrigerant.</li> <li>9. Velocity in risers too low (A-C only).</li> <li>10. Oil trapped in line.</li> </ul>  | <ul style="list-style-type: none"> <li>1. Check for leaks and repair. Add refrigerant.</li> <li>2. Check riser sizes.</li> <li>3. Check pitch of lines and refrigerant velocities.</li> </ul>  |
| Motor Overload Relays or Circuit Breakers Open | <ul style="list-style-type: none"> <li>1. Low voltage during high load conditions.</li> <li>2. Defective or grounded wiring in motor or power circuits.</li> <li>3. Loose power wiring.</li> <li>4. High condensing temperature.</li> <li>5. Power line fault causing unbalanced voltage.</li> <li>6. High ambient temperature around the overload relay</li> </ul> | <ul style="list-style-type: none"> <li>1. Check supply voltage for excessive line drop.</li> <li>2. Replace compressor-motor.</li> <li>3. Check all connections and tighten.</li> <li>4. See corrective steps for high discharge pressure.</li> <li>5. Check Supply voltage. Notify power company. Do not start until fault is corrected.</li> <li>6. Provide ventilation to reduce heat.</li> </ul> |
| Compressor Thermal Switch Open                 | <ul style="list-style-type: none"> <li>1. Operating beyond design conditions.</li> <li>2. Discharge valve partially shut.</li> </ul>  | <ul style="list-style-type: none"> <li>4. Add facilities so that conditions are within allowable limits.</li> <li>5. Open valve.</li> </ul>  |
| Freeze Protection Opens                        | <ul style="list-style-type: none"> <li>1. Thermostat set too low.</li> <li>2. Low water flow.</li> <li>3. Low suction pressure.</li> </ul>  | <ul style="list-style-type: none"> <li>3. Reset to 42°F (6°C) or above.</li> <li>4. Adjust flow.</li> <li>5. See "Low Suction Pressure."</li> </ul>  |





**DAIKIN APPLIED AMERICAS INC.  
LIMITED PRODUCT WARRANTY  
(North America)**

Daikin Applied Americas Inc. dba Daikin Applied (“Company”) warrants to contractor, purchaser and any owner of the product (collectively “Owner”) that Company, at its option, will repair or replace defective parts in the event any product manufactured by Company, including products sold under the brand name Daikin and used in the United States or Canada, proves defective in material or workmanship within twelve (12) months from initial startup or eighteen (18) months from the date shipped by Company, whichever occurs first. Authorized replaced parts are warranted for the duration of the original warranty. All shipments of such parts will be made FOB factory, freight prepaid and allowed. Company reserves the right to select carrier and method of shipment.

In addition, labor to repair or replace warranty parts is provided during Company normal working hours on products with rotary screw compressors, centrifugal compressors and on absorption chillers. Warranty labor is not provided for any other products.

Company’s liability to Owner under this warranty shall not exceed the lesser of the cost of correcting defects in the products sold or the original purchase price of the products.

**PRODUCT STARTUP ON CENTRIFUGAL AND SCREW COMPRESSOR PRODUCTS IS MANDATORY** and must be performed by a Daikin Applied or a Company authorized service representative.

It is Owner’s responsibility to complete and return the Registration and Startup Forms accompanying the product to Company within ten (10) days of original startup. If this is not done, the ship date and the startup date will be deemed the same for warranty period determination, and this warranty shall expire twelve (12) months from that date.

**EXCEPTIONS**

1. If free warranty labor is available as set forth above, such free labor does not include diagnostic visits, inspections, travel time and related expenses, or unusual access time or costs required by product location.
2. Refrigerants, fluids, oils and expendable items such as filters are not covered by this warranty.
3. This warranty shall not apply to products or parts which (a) have been opened, disassembled, repaired, or altered by anyone other than Company or its authorized service representative; or (b) have been subjected to misuse, negligence, accidents, damage, or abnormal use or service; or (c) have been operated, installed, or startup has been provided in a manner contrary to Company’s printed instructions, or (d) were manufactured or furnished by others and which are not an integral part of a product manufactured by Company; (e) have been exposed to contaminants, or corrosive agents, chemicals, or minerals, from the water supply source, or (f) have not been fully paid for by Owner.

**ASSISTANCE**

To obtain assistance or information regarding this warranty, please contact your local sales representative or a Daikin Applied office.

**SOLE REMEDY**

**THIS WARRANTY CONSTITUTES THE OWNER’S SOLE REMEDY. IT IS GIVEN IN LIEU OF ALL OTHER WARRANTIES. THERE IS NO IMPLIED WARRANTY OF MERCHANTABILITY OR FITNESS FOR A PARTICULAR PURPOSE. IN NO EVENT AND UNDER NO CIRCUMSTANCE SHALL COMPANY BE LIABLE FOR INCIDENTAL, INDIRECT, SPECIAL, CONTINGENT OR CONSEQUENTIAL DAMAGES, WHETHER THE THEORY BE BREACH OF THIS OR ANY OTHER WARRANTY, NEGLIGENCE OR STRICT LIABILITY IN TORT.**

No person (including any agent, sales representative, dealer or distributor) has the authority to expand the Company’s obligation beyond the terms of this express warranty or to state that the performance of the product is other than that published by Company.

For additional consideration, Company will provide an extended warranty(ies) on certain products or components thereof. The terms of the extended warranty(ies) are shown on a separate extended warranty statement.

### ***Daikin Applied Training and Development***

Now that you have made an investment in modern, efficient Daikin Applied equipment, its care should be a high priority. For training information on all Daikin Applied HVAC products, please visit us at [www.DaikinApplied.com](http://www.DaikinApplied.com) and click on training, or call 540-248-9646 and ask for the Training Department.

### ***Warranty***

All Daikin Applied equipment is sold pursuant to Daikin Applied standard terms and conditions of sale, including Limited Product Warranty. Consult your local Daikin Applied representative for warranty details. To find your local Daikin Applied representative, go to [www.DaikinApplied.com](http://www.DaikinApplied.com).

This document contains the most current product information as of this printing. For the most up-to-date product information, please go to [www.DaikinApplied.com](http://www.DaikinApplied.com).

