



Installation and Maintenance Manual

IM 930-12

Group: **WSHP**

Part Number: **910301837**

Date: **January 2020**

Enfinity™ Vertical Water Source Heat Pumps

Model VFC Standard Range & VFW Geothermal

Unit Sizes 009 – 070 / R-410A Refrigerant



Receiving and Storage	5	MicroTech III Unit Controller with Optional EC Motor, and I/O Expansion Module 208/230/460/60/3-Phase 28
Pre-Installation	5	MicroTech III Unit Controller with PSC Motor, and I/O Expansion Module for Hot Gas Reheat Control (Unit Sizes 019-070) 208/230/60/1-Phase.
Locating The Unit	6	29
Unit Installation	7	Thermostat Connections
Ductwork and Attenuation	7	7-Day Programmable Electronic Thermostat (P/N 668375301).
Discharge Ducting	7	30
Return Air Ducting	7	Non-Programmable Electronic Thermostat (P/N 668375401).
Ventilation Air	8	30
Cleaning & Flushing Water System.	8	Optional Remote Sensor (P/N 66720401)
Water System Quality	9	30
Operating Limits	10	MicroTech III Wall-Mounted Room Temperature Sensors (Kit P/N 669529101, 669529201, 669529001).
Antifreeze Correction Factors	10	31
Piping	11	Wiring Sensors to the MicroTech III Unit Controller . 31
Electrical Connections.	12	Additional Accessories – General
MicroTech® III Unit Controller	13	Motorized Isolation Valve & Relay.
I/O Expansion Module	17	32
MicroTech III Controller With LONWORKS® Communication Module	19	Pump Restart Relay Kit P/N 061419001
MicroTech III Controller with BACnet Communication Module	20	32
Prior To Start-up	22	Multiple Unit Control (up to 3 units) (P/N 056794201)
Changing PSC Fan Motor Speed	22	32
Start-up	24	Hot Gas/Water Reheat Dehumidification (Option) (Unit Sizes 019 – 070).
Typical Wiring Diagrams	25	33
MicroTech III Unit Controller (Standalone) – 208/230/460/575/60Hz/3-Phase	25	Troubleshooting
MicroTech III Unit Controller with Optional EC Motor, and I/O Expansion Module - 208/230/265/277/60 Hz/1-Phase	26	The in and outs of R-410A
MicroTech III Unit Controller with Optional EC Motor, Electric Heat Coil & I/O Expansion Module – 208/230/460/60 Hz/3-Phase	27	34
		Lubrication.
		34
		Charging
		34
		General Maintenance
		34
		MicroTech III Unit Controller LED Faults
		35
		Typical Refrigeration Cycles
		38
		General Use and Information
		39
		Water Source Heat Pump Equipment Check, Test and Start Form
		40

Hazard Identification Information

 **WARNING**

This Installation and Maintenance bulletin is intended to provide the proper procedures for installing a Daikin Console Water Source Heat Pump. Failure to follow these procedures can cause property damage, severe personal injury or death. Additional, failure to follow these procedures can cause premature failure of this equipment or cause erratic unit operation, resulting in diminished unit performance. Disregarding these directions may further lead to suspension or revocation of the manufacturer's warranty.

 **DANGER**

Dangers indicate a hazardous situation, which will result in death or serious injury if not avoided.

 **CAUTION**

Cautions indicate potentially hazardous situations, which can result in personal injury or equipment damage if not avoided.

 **WARNING**

Warnings indicate potentially hazardous situations, which can result in property damage, severe personal injury, or death if not avoided.

Note: *Indicates important details or clarifying statements for information presented.*

Category	Code Item	Code Option	Code Designation & Description
Product Category	01	1	W = Water Source Heat Pump
Product Identifier	02	2-4	VFC = R410A, Floor Mounted, Standard Range VFW = R410A, Floor Mounted, Geothermal Range
Design Series (Vintage)	03	5	1 = A Design 2 = B Design 3 = C Design 4 = D Design
Nominal Capacity	04	6-8	009 = 9,000 Btuh Nominal Cooling 012 = 12,000 Btuh Nominal Cooling 015 = 15,000 Btuh Nominal Cooling 019 = 19,000 Btuh Nominal Cooling 024 = 24,000 Btuh Nominal Cooling 030 = 30,000 Btuh Nominal Cooling 036 = 36,000 Btuh Nominal Cooling 042 = 42,000 Btuh Nominal Cooling 048 = 48,000 Btuh Nominal Cooling 060 = 60,000 Btuh Nominal Cooling 070 = 70,000 Btuh Nominal Cooling
Controls	05	9	B = MicroTech® III Unit Controller C = MicroTech III Unit Controller w/LonWorks® Communication Module D = MicroTech III Unit Controller w/BACnet® Communication Module F = Microtech III Unit Controller w/BACnet Comm Module - WSHP System
Voltage	06	10	A = 115-60-1 (Sizes 007-012 only) E = 208-230/60/1 J = 265/277-60-1 F = 208-230/60/3 K = 460/60/3* L = 575/60/3
Return Air	08	12	L = Left R = Right
Discharge Air	09	13	T = Top
Blower Motor	10	14-15	01 = Standard PSC 04 = ECM
Construction Type	12	18	B = Standard w/2" Filter Rack C = Standard w/Compressor Sound Blanket D = Standard w/Compressor Sound Blanket and 2" Filter Rack E = Indoor Air Quality (IAQ) Closed-Cell Foam Insulation F = Indoor Air Quality (IAQ) w/2" Filter Rack G = Indoor Air Quality (IAQ) w/Compressor Sound Blanket H = Indoor Air Quality (IAQ) w/Compressor Sound Blanket and 2" Filter Rack
Heating Options	14	20	A = 5.0 kW Electric Heat B = 10.0 kW Electric Heat
Dehumidification	15	21-22	AA = Hot Gas Reheat Coil
Refrigerant	20	33	A = R410A
Cabinet Electrical	22	35-37	75VA = 75VA Control Transformer
Water Flow Control	23	38	C = 2-Way Motorized 1/2" Isolation Valve, General Close-Off Pressure N.C. V = 2-Way Motorized 1/2" Isolation Valve, General Close-Off Pressure N.O. H = 2-Way Motorized 1/2" Isolation Valve, High Close-Off Pressure N.C. D = 2-Way Motorized 3/4" Isolation Valve, General Close-Off Pressure N.C. K = 2-Way Motorized 3/4" Isolation Valve, General Close-Off Pressure N.O. J = 2-Way Motorized 3/4" Isolation Valve, High Close-Off Pressure N.C.
Color	24	39	A = Antique Ivory Y = None
Extended Warranty, Parts Only	28	43	Y = None E = 1-Year, Entire Unit Parts Only C = 4-Year Parts (Compressor Only) R = 4-Year Parts (Refrigerant Circuit)

Notes: * A 460 volt, 3-phase unit that utilize an EC fan motor will need a 4-wire WYE voltage supply with 3 hot leads and a neutral wire. To power the EC motor with neutral and one hot for 277/60/1 voltage to the EC motor.

⚠ CAUTION

Sharp edges can cause personal injury. Avoid contact with them. Use care and wear protective clothing, safety glasses and gloves when handling parts and servicing heat pumps.

Upon receipt of the equipment, check carton for visible damage. Make a notation on the shipper's delivery ticket before signing. If there is any evidence of rough handling, immediately open the cartons to check for concealed damage. If any damage is found, notify the carrier within 48 hours to establish your claim and request their inspection and a report. The Warranty Claims Department should then be contacted.

Do not stand or transport the machines on end. For storing, each carton is marked with "up" arrows.

In the event that elevator transfer makes up-ended positioning unavoidable, do not operate the machine until it has been in the normal upright position for at least 24 hours.

Temporary storage at the job site must be indoor, completely sheltered from rain, snow, etc. High or low temperatures naturally associated with weather patterns will not harm the units. Excessively high temperatures, 140°F (60°C) and higher, may deteriorate certain plastic materials and cause permanent damage.

IMPORTANT

This product was carefully packed and thoroughly inspected before leaving the factory. Responsibility for its safe delivery was assumed by the carrier upon acceptance of the shipment. Claims for loss or damage sustained in transit must therefore be made upon the carrier as follows:

VISIBLE LOSS OR DAMAGE

Any external evidence of loss or damage must be noted on the freight bill or carrier's receipt, and signed by the carrier's agent. Failure to adequately describe such external evidence of loss or damage may result in the carrier's refusal to honor a damage claim. The form required to file such a claim will be supplied by the carrier.

CONCEALED LOSS OR DAMAGE

Concealed loss or damage means loss or damage which does not become apparent until the product has been unpacked. The contents may be damaged in transit due to rough handling even though the carton may not show external damages. When the damage is discovered upon unpacking, make a written request for inspection by the carrier's agent within fifteen (15) days of the delivery date and file a claim with the carrier.

Pre-Installation

⚠ WARNING

The installer must determine and follow all applicable codes and regulations. This equipment presents hazards of electricity, rotating parts, sharp edges, heat and weight. Failure to read and follow these instructions can result in property damage, severe personal injury or death. This equipment must be installed by experienced, trained personnel only.

1. To prevent damage, do not operate this equipment for supplementary heating and cooling during the construction period.
 2. Inspect the carton for any specific tagging numbers indicated by the factory per a request from the installing contractor. At this time the voltage, phase and capacity should be checked against the plans.
 3. Check the unit size against the plans to verify that the unit is being installed in the correct location.
 4. Before installation, check the available closet dimensions versus the dimensions of the unit.
 5. Note the location and routing of water piping, condensate drain piping, and electrical wiring. The locations of these items are clearly marked on submittal drawings.
 6. The installing contractor will find it beneficial to confer with piping, sheet metal, and electrical foremen before installing any unit.
- Note:** *Check the unit data plate for correct voltage with the plans before installing the equipment. Also, make sure all electrical ground connections are made in accordance with local code.*
7. The contractor shall cover the units to protect the machines during finishing of the building. This is critical while spraying fireproofing material on bar joists, sandblasting, spray painting and plastering.
 8. The overall opening of the doorway to mechanical room must be 2" wider than the unit for easy installation and/or removal.

Table 1: Overall Unit Dimensions

Unit Size	Dimensions
009 – 012	22¼"D x 20"W x 37"H
015 – 024	24¼"D x 23"W x 46½"H
030 – 036	24¼"D x 23"W x 50½"H
042 – 048	32½"D x 25"W x 46½"H
060 – 070	32½"D x 25"W x 58½"H

Note: *Dimensions are approximate.*

1. Locate the unit in an area that allows for easy removal of the filter and access panels, and has enough space for service personnel to perform maintenance or repair. Provide sufficient room to make water, electrical and duct connections.
2. Make sure that sufficient access has been provided for installing the unit, including clearance for duct collars and fittings at water and electrical connections.
3. Allow adequate room around the unit for a condensate piping.
4. The unit can be installed “free standing” in an equipment room. However, closet installations are more common for small vertical type units.

Generally, the unit is located in the corner of a closet with the non-ducted return air facing 90° to the door and the major access panels facing the door as in Figure 1. Alternatively, the unit can have a ducted return air with the opening facing the door and the major access panels facing 90° to the door as in Figure 2.

5. Unit must be located on top of a vibration absorbing material such as a rubber (Isolation pad) that is the same size as the base of the unit, to minimize vibration and noise. See Figure 9 on page 10.

Minimum distance requirement from return air duct collar to wall for non-ducted units.

Model	Distance
009 – 012.....	5 inches
015 – 024.....	5 inches
030 – 036.....	6 inches
042 – 048.....	8 inches
060 – 070.....	10 inches

Figure 1: Typical closet installation with louver door return (non-ducted)

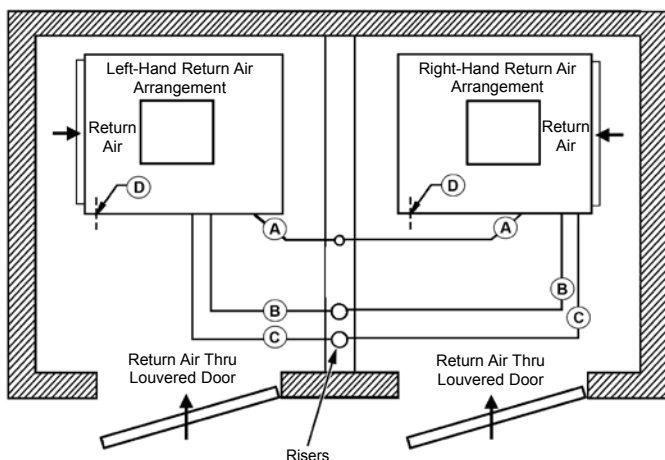

- A Condensate
- B Water Return
- C Water Supply
- D Low Voltage Control Wiring (Electric Entrance)

Figure 2: Typical closet installation with ducted return

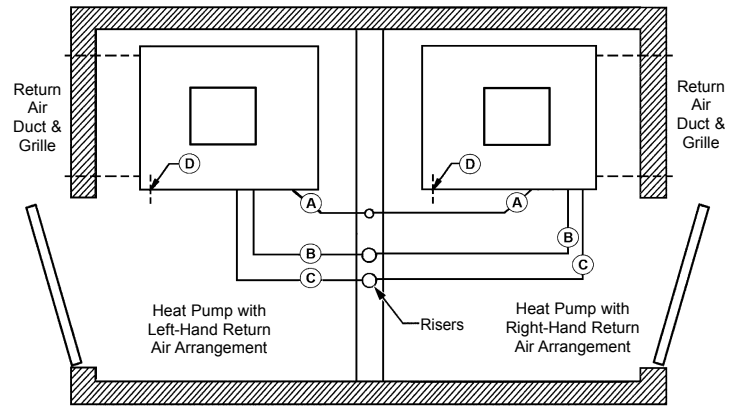

- A Condensate
- B Water Return
- C Water Supply
- D Low Voltage Control Wiring (Electric Entrance)
- E Line Voltage Unit Power (Electric Entrance)

Figure 3: Unit Electrical and Piping Locations

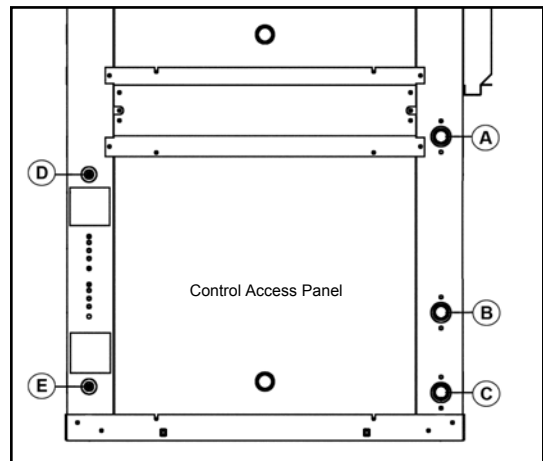

Ductwork and Attenuation

Discharge ductwork is normally used with these units. Where return air ductwork is required, the unit is supplied with a 1" filter rack/duct collar for connection of return air ductwork. An optional 2" return air duct collar filter rack is available as a field-installed accessory or a factory-installed, selectable option. The 2" filter rack allows tool less entry for easy filter replacement.

Figure 4: Sizes 007 thru 070 Optional 2" Return Air Duct Collar Filter Rack

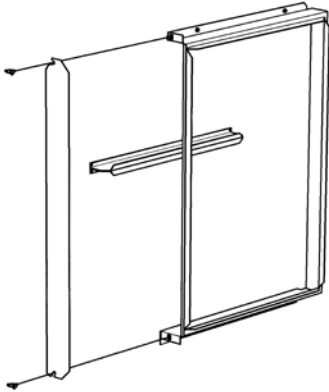

Discharge Ducting

All ductwork should conform to industry standards of good practice as described in ASHRAE Systems Guide. A field supplied discharge duct system will normally consist of a flexible connector at the unit, a non-insulated transition piece to the full duct size, a short run of duct, an elbow without vanes, and a trunk duct teeing into a branch circuit with discharge diffusers as shown in Figure 5.

Figure 5: Suggested Unit Ducting

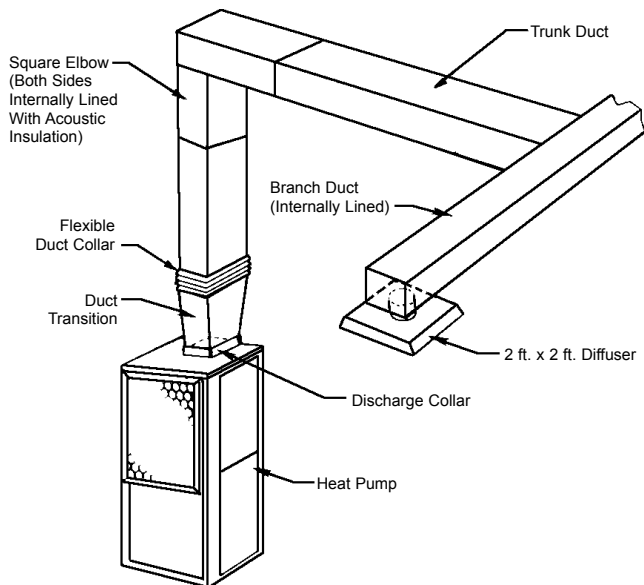

The transition piece must not have an angle greater than 30° or severe loss of air performance can result. Do not connect the full duct size to the unit without using a transition piece down to the size of the discharge collar on the unit. With metal duct material, the sides of the elbow and entire branch duct should be internally lined with acoustic insulation for sound attenuation. Glass fiber duct board material is more absorbing and may permit omission of the flexible connector.

The ductwork should be laid out so that there is no line of sight between the unit discharge and the distribution diffusers.

Return Air Ducting

Return air ducts can be brought in through a wall grille and then to the unit. The return duct system will normally consist of a flexible connector at the unit and a trunk duct to the return air grille. With metal duct material, the return air duct should be internally lined with acoustic insulation for sound attenuation. Glass fiber duct board material is more absorbing and may permit omission of the flexible connector.

Return air ductwork to the unit requires the 1" (25mm) standard return air duct collar or the optional 2" (51mm) filter rack kit (see Figure 4). The 2" filter rack kit allows for side filter removal. A flexible duct collar can then be attached between a duct transition and the return air ductwork. The return air duct transition must be the same size as the return air coil face area.

Connections of supply and return air ductwork should be made at the duct collar of the unit. Do not puncture the unit cabinet with sheet metal screws as this can damage the drain pan or the coil.

Figure 6: Suggested Return Air Unit Ducting

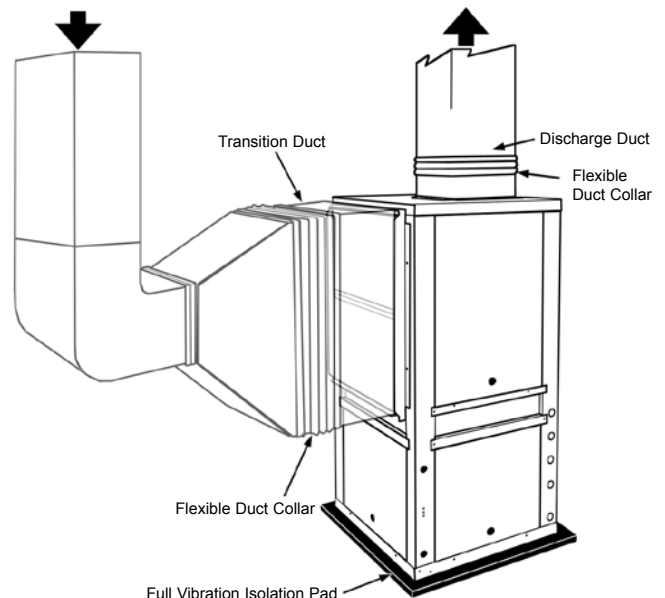

Ventilation Air

Outside air may be required for ventilation. The temperature of the ventilation air must be controlled so that mixture of outside air and return air entering the unit does not exceed application limits. It is also general practice to close off the ventilation air system during unoccupied periods (night setback).

The ventilation air system is generally a separate building subsystem with distribution ductwork. To provide thorough mixing of the outside and return air, introduce the outside air in close proximity to the return air plenum inlet. Do not duct outside air directly to the unit inlet. See "Operating Limits" on page 9.

CAUTION

Prior to making piping connections, contractor must clean and flush water loop system. Failure to clean/flush system may result in nuisance tripping and premature component failure.

Cleaning & Flushing Water System

1. Prior to first operation of any unit, the water circulating system must be cleaned and flushed of all construction dirt and debris. If the units are equipped with water shutoff valves, either electric or pressure operated, the supply and return runouts must be connected together at each unit location. This will prevent the introduction of dirt into the unit. See Figure 7.

Figure 7: Connect the runouts together

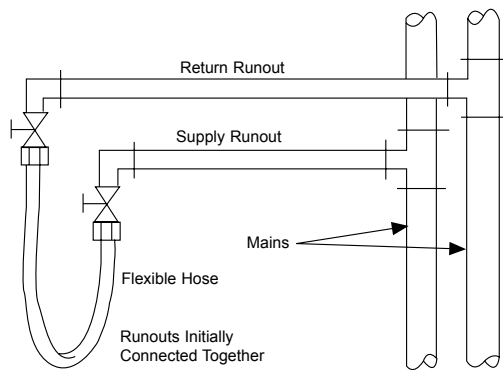

2. Fill the system at the city water makeup connection with all air vents open. After filling, close all air vents. The contractor should start main circulator with the pressure reducing valve open. Check vents in sequence to bleed off any trapped air, ensuring circulation through all components of the system. Power to the heat rejector unit should be off, and the supplementary heat control set at 80°F (27°C).

While circulating water, the contractor should check and repair any leaks in the unit and surrounding piping. Drains at the lowest point(s) in the system should be opened for initial flush and blow-down, making sure city water fill valves are set to make up water at the same rate. Check the pressure gauge at pump suction and manually adjust the makeup to hold the same positive steady pressure both before and after opening the drain valves. Flush should continue for at least two hours or longer until the drain water is clean and clear.

CAUTION

Units must be checked for water leaks upon initial water system start-up. Water leaks may be a result of mishandling or damage during shipping. Failure by the installing contractor to check for leaks upon start-up of the water system could result in property damage.

3. Shut off supplemental heater and circulator pump and open all drains and vents to completely drain down the system. Short circuited supply and return runouts should now be connected to the unit supply and return connections. Do not use sealers at the swivel flare connections of hoses.
4. Flush system with water for 2 hours or longer until water is clean.
5. Refill the system with clean water. Test the water using litmus paper for acidity, and treat as required to leave the water slightly alkaline (pH 7.5 to 8.5). The specified percentage of antifreeze may also be added at this time. Use commercial grade antifreeze designed for HVAC systems only. Do not use automotive grade antifreeze. Once the system has been filled with clean water and antifreeze (if used), precautions should be taken to protect the system from dirty water conditions.

Note: Contact a local water treatment company to confirm water clarity prior to unit operation.

Dirty water will result in system wide degradation of performance and solids may clog system-wide valves, strainers, flow regulators, etc. Additionally, the heat exchanger may become clogged which reduces compressor service life or causes premature failure.

6. Set the loop water controller heat add setpoint to 70°F (21°C) and the heat rejection setpoint to 85°F (29°C). Supply power to all motors and start the circulating pumps. After full flow has been established through all components including the heat rejector (regardless of season) and the vented air and loop temperatures have been stabilized, each of the units will be ready for check, test and start-up, air balancing, and water balancing.

Water System Quality

The cleaning, flushing and chemical treatment of a water source heat pump system is fundamental to efficient operation and the life expectancy of the system.

Potential system problems produced by the use of water fall into three general categories:

- **Scale formation** – Mineral deposits which result from the crystallization and precipitation of dissolved salts in the water. The deposits form an insulating barrier, reducing the heat transfer rate and impeding the circulation of fluids due to increased pressure drop.
- **Corrosion** – Decomposition of the metal caused by absorption of gases from the air. Corrosion may occur in any metal component of the system.
- **Organic growths** – Slime and algae which form under certain environmental conditions, and can reduce the heat transfer rate by forming an insulating coating or can promote corrosion by pitting.

The system water should be evaluated for degrees of impurity, with testing available from independent testing labs, health departments or state agencies.

Table 2 is a list of water characteristics, the potential impurities and their results and the recommended treatment.

Avoiding Potential Problems

As shown in Table 2, all water contains some degree of impurities which may affect the performance of a heat pump system. The use of a cupro-nickel coil can help avoid potential problems. Water flow rates should:

- Be high enough that the temperature rise through the heat exchanger does not exceed 10° F when operating in the cooling mode.
- Not exceed 4 GPM per nominal ton. Flow rates that have velocities of 10 feet per second or more may cause pipe erosion and heat exchanger failure.

Table 2: Water quality conditions & applications

Potential Problem	Chemical(s) or Condition	Range for Copper Heat Exchangers	Range of Cupronickel Heat Exchanger
Scaling	Calcium & Magnesium Carbonate	Less than 350 ppm	Less than 350 ppm
Corrosion	pH Range	7 – 9	5 – 9
	Total Dissolved Solids	Less than 1000 ppm	Less than 1500 ppm
	Ammonia, Ammonium Hydroxide	Less than 0.5 ppm	Less than 0.5 ppm
	Ammonium Chloride, Ammonium Nitrate	Less than 0.5 ppm	Less than 0.5 ppm
	Calcium Chloride/ Sodium Chloride	Less than 125 ppm	Less than 125 ppm - Note 4
	Chlorine	Less than 0.5 ppm	Less than 0.5 ppm
Biological Growth	Hydrogen Sulfide	None Allowed	None Allowed
	Iron Bacteria	None Allowed	None Allowed
Erosion	Iron Oxide	Less than 1 ppm	Less than 1 ppm
	Suspended Solids	Less than 10 ppm	Less than 10 ppm
	Water Velocity	Less than 8 ft./s	Less than 12 ft./s

- Notes:**
1. Water hardness in ppm is equivalent to hardness in mg/L.
 2. Grains/gallon = ppm divided by 17.1.
 3. Copper and cupronickel heat exchangers are not recommended for pool applications for water outside the range of the table. Secondary heat exchangers are required for applications not meeting the requirements shown above.
 4. Salt water applications (approx. 25,000 ppm) require secondary heat exchangers due to copper piping between the heat exchanger and the unit fittings.

Operating Limits

This equipment is designed for indoor installation only. Sheltered locations such as attics, garages, etc., generally will not provide sufficient protection against extremes in temperature and/or humidity, and equipment performance, reliability, and service life may be adversely affected.

Table 3: Air limits in °F (°C)

Air Limits	Standard Range Units		Geothermal Range Units	
	Cooling	Heating	Cooling	Heating
Minimum Ambient Air	50°F (10°C)	50°F (10°C)	40°F (4°C)	40°F (4°C)
Rated Ambient	80°F (27°C)	70°F (21°C)	80°F (27°C)	70°F (21°C)
Maximum Ambient Air	100°F (38°C)	85°F (29°C)	100°F (38°C)	85°F (29°C)
Minimum Entering Air	50°F (10°C)	50°F (10°C)	50°F (10°C)	40°F (4°C)
Rated Entering Air	80/67°F (27°/19°C)	70°F (21°C)	80/67°F (27°/19°C)	70°F (21°C)
Maximum Entering Air	100/83°F (38/28°C)	80°F (27°C)	100/83°F (38/28°C)	80°F (27°C)

Table 4: Water limits

Water Limits	Standard Range Units		Geothermal Range Units	
	Cooling	Heating	Cooling	Heating
Minimum Entering Water	55°F (13°C)	55°F (13°C)	30°F (-1°C)	20°F (-6°C)
Normal Entering Water	85°F (29°C)	70°F (21°C)	77°F (25°C)	40°F (4°C)
Maximum Entering Water	110°F (43°C)	90°F (32°C)	110°F (43°C)	90°F (32°C)
Minimum GPM/Ton	1.5			
Nominal GPM/Ton	3.0			
Maximum GPM/Ton	4.0			

Notes: 1. Maximum and minimum values may not be combined. If one value is at maximum or minimum, the other two conditions may not exceed the normal condition for standard units. Extended range units may combine any two maximum conditions, but not more than two, with all other conditions being normal conditions.

2. This is not a normal or continuous operating condition. It is assumed that such a start-up is for the purpose of bringing the building space up to occupancy temperature.

Antifreeze Correction Factors

Table 5: Ethylene Glycol

	10%	20%	30%	40%	50%
Cooling Capacity	0.9950	0.9920	0.9870	0.9830	0.9790
Heating Capacity	0.9910	0.9820	0.9770	0.9690	0.9610
Pressure Drop	1.0700	1.1300	1.1800	1.2600	1.2800

Table 6: Propylene Glycol

	10%	20%	30%	40%	50%
Cooling Capacity	0.9900	0.9800	0.9700	0.9600	0.9500
Heating Capacity	0.9870	0.9750	0.9620	0.9420	0.9300
Pressure Drop	1.0700	1.1500	1.2500	1.3700	1.4200

Table 7: Methanol

	10%	20%	30%	40%	50%
Cooling Capacity	0.9980	0.9720	–	–	–
Heating Capacity	0.9950	0.9700	–	–	–
Pressure Drop	1.0230	1.0570	–	–	–

Table 8: Ethanol

	10%	20%	30%	40%	50%
Cooling Capacity	0.9910	0.9510	–	–	–
Heating Capacity	0.9950	0.9600	–	–	–
Pressure Drop	1.0350	0.9600	–	–	–

Piping

1. All units should be connected to supply and return piping in a two-pipe reverse return configuration. A reverse return system is inherently self-balancing and requires only trim balancing where multiple quantities of units with different flow and pressure drop characteristics exist in the same loop. Check for proper water balance by measuring differential temperature reading across the water connections. For proper water flow, the differential temperature should be 12°F to 14°F (5°C to 8°C) for units in cooling mode. A direct return system may also work, but proper water flow balancing is more difficult to achieve and maintain.
1. The piping must comply with local codes.

⚠ WARNING

Polyester Oil, commonly known as POE oil is a synthetic oil used in many refrigeration systems, and may be present in this Daikin product. POE oil, if ever in contact with PVC/CPVC will coat the inside wall of PVC/CPVC pipe causing environmental stress fractures. Although there is no PVC/CPVC piping in this product, please keep this in mind when selecting piping materials for your application, as system failure and property damage could result.

2. Supply and return runouts usually join the unit via short lengths of high pressure flexible hose which are sound attenuators for both unit operating noise and hydraulic pumping noise. One end of the hose should have a swivel fitting to facilitate removal for service. Hard piping also can be brought directly to the unit. This option is not recommended since no vibration or noise attenuation can be accomplished. The hard piping must have unions to facilitate unit removal. See Figure 8, Figure 9, and Figure 10 for typical piping details.

Figure 8: Typical Vertical Unit Piping

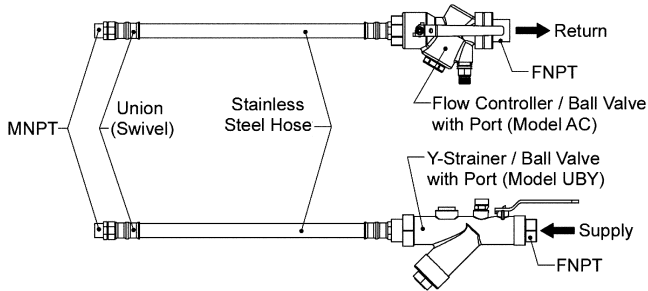

3. Some flexible hose threaded fittings are supplied with sealant compound. If not, apply Teflon tape for a tight seal.
4. Supply and return shutoff valves are required at each unit. The return valve is used for balancing and should have a "memory stop" so that it can always be closed off but can only be reopened to the proper position for the flow required.
5. Do not connect any unit to the supply and return piping until the water system has been cleaned and flushed completely. After the cleaning and flushing has taken

place, the initial connection should have all valves wide open in preparation for water system flushing (see "Cleaning & Flushing Water System" on page 7).

6. Condensate piping should be installed per local codes. Each unit includes a condensate connection.
7. Units are internally trapped.
8. Do not locate any point in the drain system above the drain connection of any unit.
9. Automatic flow controlled devices must not be installed prior to system cleaning and flushing.
10. A high point of the piping system must be vented.
11. Check local code for the need for dielectric fittings.

Note: Do not over-torque fittings. The maximum torque without damage to fittings is 30 foot pounds. If a torque wrench is not available, use as a rule of thumb, finger-tight plus one quarter turn.

Figure 9: Typical Vertical Installation and Unit Piping

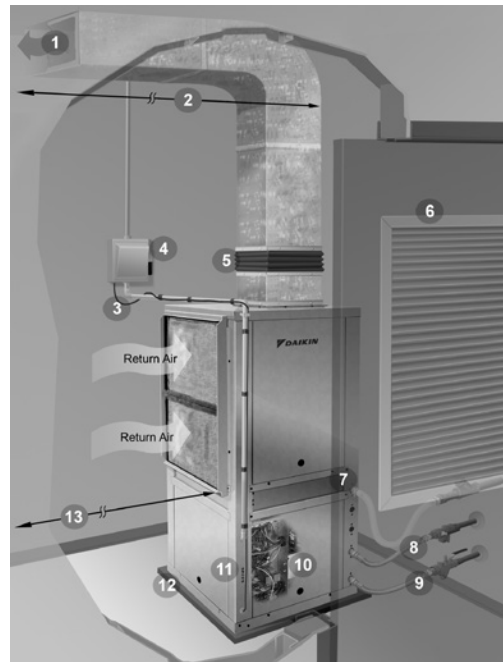

- 1 Supply Air Ducting
- 2 Acoustical Thermal Lining (10 ft.)
- 3 Line Voltage - 7/8" (22 mm) Hole
- 4 Low Voltage - 7/8" (22 mm) Hole
- 5 Flexible Duct Collar
- 6 Louvered Door for Return Air
- 7 Condensate Drain Connection
- 8 Flexible Return Hose with Flow Controller/Ball Valve (3/4" FPT)
- 9 Flexible Supply Hose with Y-Strainer/Ball Valve (3/4" FPT)
- 10 Access Panel to Controller
- 11 LED Annunciator Status Lights
- 12 Vibration Isolation Pad

Electrical Connections

Note: *Installation and maintenance must be performed only by qualified personnel who are familiar with local codes and regulations, and are experienced with this type of equipment.*

WARNING



Hazardous Voltage! The installer must determine and follow all applicable codes and regulations. This equipment presents hazards of electricity, rotating parts, sharp edges, heat and weight. Failure to read and follow these instructions can result in property damage, severe personal injury or death.

CAUTION

Sharp edges can cause personal injury. Avoid contact with them.

Figure 10: Unit Electrical and Piping Locations

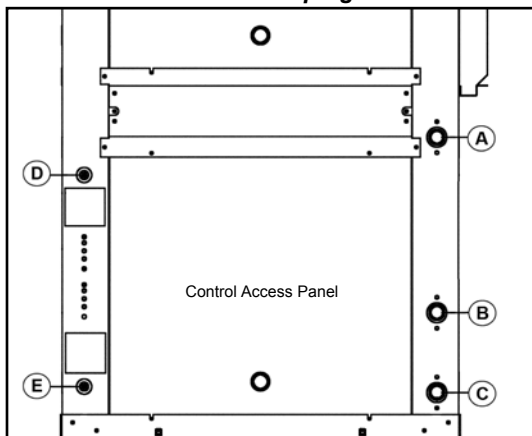

- A Condensate
- B Water Return
- C Water Supply
- D Low Voltage Control Wiring (Electric Entrance)
- E Line Voltage Unit Power (Electric Entrance)

Operating Voltages

115/60/1	104 volts min.; 127 volts max.
208-230/60/1	197 volts min.; 253 volts max.
265/60/1.....	238 volts min.; 292 volts max.
460/60/3.....	414 volts min.; 506 volts max.
575/60/3.....	515 volts min.; 632 volts max.

Note: *Voltages listed are to show voltage range. However, units operating with over voltage and under voltage for extended periods of time will experience premature component failure. Three phase system unbalance should not exceed 2%.*

General

1. Verify the compatibility between the voltage and phase of the available power and that shown on the unit data plate. Line and low voltage wiring must comply with local codes or the National Electrical Code, whichever applies.
2. Apply correct line voltage to the unit. A 7/8" (22mm) hole. A disconnect switch near the unit is required by code. Power to the unit must be sized correctly and have dual element (Class RK5) fuses or an HACR circuit breaker for branch circuit overcurrent protection. See the data plate for correct ratings.
3. Connect the thermostat/subbase wiring with the power "off" to the unit.

230 Volt Operation

All 208-230 volt single-phase and three-phase units are factory wired for 208 volt operation. For 230 phase operation, the line voltage tap on the 24-volt transformer must be changed. Disconnect and cap the red lead wire and interchange it with the orange lead wire on the primary of the 24-volt transformer.

Fan Assembly

All fan motors are multi-speed PSC or optional ECM (sizes 019-070) type with integral mounting brackets and thermal overload protection. The motor is isolated from the fan housing for minimum vibration transmission. PSC Fan motors have a terminal strip on the motor body for simple motor speed change without going back to the control box. See "Changing PSC Fan Motor Speed" on page 21.

All the fan/motor assemblies have a removable orifice ring on the housing to accommodate motor and fan wheel removal without disconnecting the ductwork. The fan housing protrudes through the cabinet allowing adequate material for connection of flexible duct. Each model unit is shipped from the factory for maximum performance and minimum sound requirements. Fan sound levels and performance can be affected by external static pressure.

MicroTech® III Unit Controller

The MicroTech III Unit Controller includes built-in features such as random start, compressor time delay, shutdown, condensate overflow protection, defrost cycle, brownout, and LED/fault outputs. Refer to Table 11 on page 14.

The unit has been designed for operation with a microelectronic wall thermostat selected by the manufacturer. Do not operate the unit with any other type of wall thermostat.

Each unit has a printed circuit board control system. The low voltage output from the low voltage terminal strip is AC voltage to the wall thermostat. R is A/C voltage output to the wall stat.

The 24 volt low voltage terminal strip is set up so R-G energizes the fan, R-Y1 energizes the compressor for cooling operation, R-W1 energizes the compressor and reversing valve for heating operation. The reversing valve is energized in the heating mode. The circuit board has a fan interlock circuit to energize the fan whenever the compressor is on if the thermostat logic fails to do so.

The output to the wall stat is AC current. Terminal (R) on the wall stat can be connected to terminal (R) on the PC board for AC voltage.

R = AC current **R to G** = fan only

R to Y1 = cooling **R to W1** = heat

The MicroTech III unit controller has a lockout circuit to stop compressor operation if any one of its safety switches opens (high pressure switch and low pressure switch. If compressor low suction temperature is detected, the unit will go into the cooling mode for 60 seconds to defrost any slush in the water-to-refrigerant heat exchanger. If the condensate sensor detects a filled drain pan, the compressor operation will be suspended only in the cooling mode. The unit is reset by opening and closing the disconnect switch on the main power supply to the unit in the event the unit compressor operation has been suspended due to low temperature (freezestat) switch, high pressure switch, or low pressure switch. The unit does not have to be reset on a condensate overflow detection.

The MicroTech III unit controller fault output sends a signal to an LED on a wall thermostat. Table 10 on page 13 shows for which functions the fault output is “on” (sending a signal to the LED), when the “A” terminal is configured by JP4 being open.

Remote Reset of Automatic Lockouts

The Remote Reset feature provides the means to remotely reset some lockouts.

There are (3) means to reset an automatic lockout condition:

1. Using the thermostat create 2 demands for capacity within 30 seconds

2. Press the room sensor or thermostat timed override/reset button for more than 10 seconds
3. Turn the unit power off

When the cause of the fault condition has been cleared, and the unit transitions from not requiring any capacity to needing any capacity twice within 30 seconds (accomplished by user manipulation of the Heat/Cool/Auto/Off switch on the thermostat), an alarm reset equivalent to a tenant override button reset is generated. The intelligent reset counter and the 24 hour timer are cleared when this type of alarm reset is generated.

Note: *This feature only applies to thermostat controlled systems.*

For room sensor controlled units, pressing the “Override” or “Reset” button for more than 10 seconds will apply a ground signal to the tenant override in (screw terminal connection at TB1 pin 4) will clear the lockout alarm once the cause of the fault condition has been cleared.

A unit power cycle can also be used to clear an automatic lockout if the conditions causing the fault have been cleared.

The Intelligent Alarm Reset feature helps to minimize nuisance trips of automatic reset lockouts caused by low temperature faults. This feature clears faults the first two times they occur within a 24-hour period and triggers an automatic lockout on the 3rd fault. The retry count is reset to zero every 24 hours.

The MicroTech III unit controller has built-in night setback operation. A “grounded” signal to the “U” terminal on TB3 of the unit control puts the unit into the unoccupied mode for night setback operation. Fan operation terminates and unit control will only respond to signal at the W2 terminal. Daytime heating and cooling operation is locked out. +24VAC to W2 energizes the compressor and reversing valve for heating operation. Night setback operation can be overridden for two hours by energizing the O on the TB2 terminal of the unit control for 4 to 10 seconds. Day thermostat setpoints then control the heating and cooling operation. The MicroTech III unit controller also accommodates shutdown operation on receipt of a “grounded” signal to the “E” input, respectively, on TB3 input terminal of the unit control.

The IV/PR(H8) terminals of the MicroTech III unit controller are used for motorized valve / pump restart. This terminal passes a voltage signal whenever the unit compressor is turned on. This signal is detected by a pump restart relay providing a N.O. or N.C. set of contacts for heat pump loop circulation pump or motorized valve control. When used with a system control (by others), the relay operation accommodates turning off circulation pumps during unoccupied periods with a safety override dependent, at minimum, on WSHP’s need.

Table 9: MicroTech® III Unit Controller Terminals Locations and Descriptions

H1 – 1	24	24 VAC Power Input
H1 – 2	C	24 VAC common
H2 – 1	SL1	Fan Low Speed Output – Switched L1
H2 – 2		Blank Terminal
H2 – 3	N	Fan Low Speed Output – Neutral
H3 – 1	HP1-1	Comp High Pressure Switch (HP1) Input Terminal 1
H3 – 2	HP1-2	Comp High Pressure Switch (HP1) Input Terminal 2
H4 – 1	1	Discharge Air Temp Sensor – Common
H4 – 2		Discharge Air Temp Sensor – Signal
H4 – 3		Leaving Water Temp Sensor – Common
H4 – 4		Leaving Water Temp Sensor – Signal
H5 – 1	1	I/O Expansion Module Common (Gnd)
H5 – 2		I/O Expansion Module Common (Gnd)
H5 – 3		I/O Expansion Module +5 VDC
H5 – 4		I/O Expansion Module SPI CE1
H5 – 5		I/O Expansion Module SPI CLK
H5 – 6		I/O Expansion Module SPI OUT
H5 – 7		I/O Expansion Module SPI IN
H5 – 8		I/O Expansion Module +12 VDC
H5 – 9		I/O Expansion Module 24 VAC
H5 – 10		I/O Expansion Module 24 VAC
H5 – 11		No Connection
H5 – 12		No Connection
H6 – 1	1	Condensate Overflow Signal Input
H6 – 2		Compressor Suction Temp Sensor (LT1) – Common
H6 – 3		Compressor Suction Temp Sensor (LT1) – Signal
H6 – 4		Compressor Low Pressure Switch (LP1) – Source Voltage
H6 – 5		Compressor Low Pressure Switch (LP1) – Signal
H6 – 6		Reversing Valve – Common
H6 – 7		Reversing Valve – Output
H7 – 1	1	No Connection

H7 – 2		No Connection
H7 – 3		Red LED Output
H7 – 4		Green LED Output
H7 – 5		Yellow LED Output
H7 – 6		Red-Green-Yellow LED Common
H8 – 1	1	Isolation Valve/Pump Request Relay N/O
H8 – 2		Isolation Valve/Pump Request Relay N/C
H8 – 3		24 VAC Common
H9 – 1	1	Room Temp Sensor & Tenant Override – Signal
H9 – 2		Room Temp Sensor & Tenant Override – Common
TB1 – 1	1	Room Sensor – Status LED Output
TB1 – 2	2	Room Sensor – Fan Mode & Unit Mode Switches
TB1 – 3	3	Room Sensor – Setpoint Adjust Potentiometer
TB1 – 4	4	Room Sensor – Room Temp Sensor & Tenant Override
TB1 – 5	5	Room Sensor – DC Signal Common
TB2 – 1	R	24 VAC
TB2 – 2	A	Alarm Output
TB2 – 3	W2	Thermostat – Heat Stage #2 Input
TB2 – 4	W1	Thermostat – Heat Stage #1 Input
TB2 – 5	Y2	Thermostat – Cool Stage #2 Input
TB2 – 6	Y1	Thermostat – Cool Stage #1 Input
TB2 – 7	G	Thermostat – Fan Input
TB2 – 8	O	Thermostat – Tenant Override Input
TB2 – 9	C	24 VAC Common
TB3 – 1	E	Emergency Shutdown Input
TB3 – 2	U	Unoccupied/Occupied Input
L1 – 1	L1 - 1	Line Voltage Terminal 1
L1 – 2	L1 - 2	Line Voltage Terminal 2
L1 – 3	L1 - 3	Line Voltage Terminal 3
N1	N1	Neutral Terminal 1
N2	N2	Neutral Terminal 2
N3	N3	Neutral Terminal 3
COMP Relay	SWL1	Switch – L1 Voltage
	L1	No Connection

Table 10: MicroTech III Controller Configuration Jumper Settings

Baseboard Description	Jumper(s)	Jumper Setting	Function
Normal / Test Mode	JP1	Open	Normal Operation
		Shorted	Service / Test Mode
Fan Operation	JP2	Open	Continuous Fan Operation (On)
		Shorted	Cycling Fan Operation (Auto)
Loop Fluid	JP3 (see warning)	Open	Water freeze protection (factory default setting)
		Shorted	Systems with anti-freeze protection
Alarm "A" Terminal Output Polarity	JP4	Open	Fault de-energizes alarm output to 0VAC.
		Shorted	Fault energizes alarm output to 24VAC.
Room Sensor Setpoint Potentiometer Range	JP5	Open	Short Range: -3 to +3 °F (-1.67 to +1.67 °C)
		Shorted	Long Range: 55 to 95 °F (12.78 to 35 °C)
Thermostat / Room Sensor	JP6	Open	Thermostat Control
		Shorted	Room Sensor Control
Not Used	JP7	Open	–
Not Used	JP8	Open	–

⚠ WARNING

Proper antifreeze/water solution is required to minimize the potential of fluid freeze-up. Jumper JP3 is factory set for water freeze protection with the jumper open. Operation with anti-freeze protection requires JP3 to be field configured for the jumper closed. If unit is employing a fresh water system (no anti-freeze protection), it is extremely important that JP3 jumper setting remains in the open position (factory default setting) in order to shut down the unit at the appropriate water temperature to protect your heat pump from freezing. Failure to do so can result in unit damage and fluid leaks."

Table 11: MicroTech III Controller Status LED's

Description	Type*	Yellow	Green	Red
Emergency Shutdown	Mode	OFF	Flash	OFF
Low Voltage Brownout	Fault	OFF	Flash	OFF
High Pressure (HP1)	Fault	OFF	OFF	Flash
Low Pressure (LP1)	Fault	OFF	OFF	ON
Low Suction Temp (LT1) Sensor Fail	Fault	Flash	Flash	ON
Low Suction Temp (LT1)	Fault	Flash	OFF	OFF
Room Temp Sensor Fail (with Room Sensor Control Only)	Fault	Flash	Flash	ON
Condensate Overflow (Cooling & Dehumidification Modes Only)	Fault	ON	OFF	OFF
Low Entering Water Temp (Heating Compressor Inhibit; No Display with Boilerless EH)	Fault	Flash	OFF	Flash
Serial EEPROM Corrupted	Fault	ON	ON	ON
Service Test Mode Enabled	Mode	Flash	Flash	Flash
Unoccupied Mode	Mode	ON	ON	OFF
Occupied, Bypass, Standby, or Tenant Override Modes	Mode	OFF	ON	OFF

*Note: * Mode / Faults are listed in order of priority.*

Note: A random start delay time between 300 and 360 seconds is generated at power up.

Figure 11: MicroTech III Unit Controller Terminal Locations

Figure 12: Location of Configuration Jumpers on the MicroTech III Unit Controller

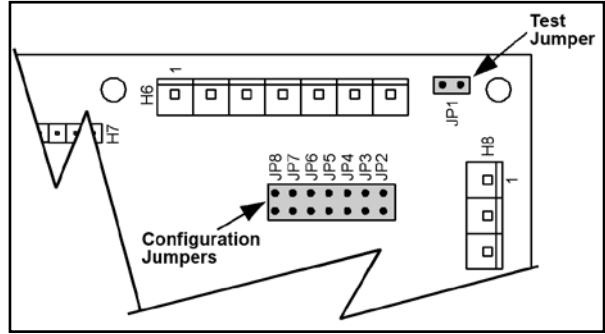
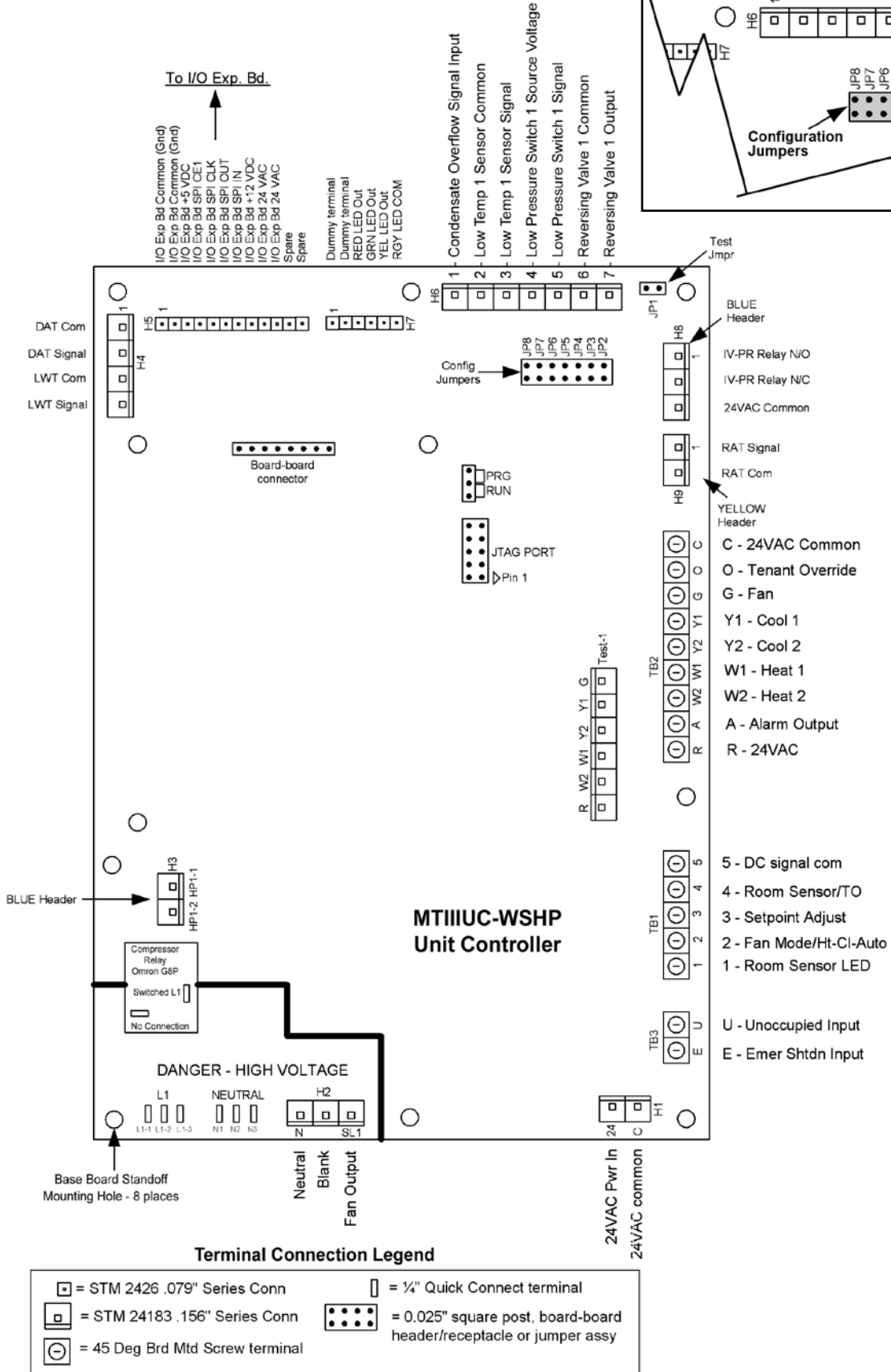

I/O Expansion Module

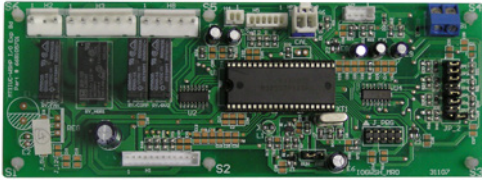

This manual covers the installation of a Daikin Vertical Floor Unit - Model VFC, VFW Water Source Heat Pump. For installation and operation information on MicroTech III unit controller and other ancillary components, see:

- IM 927 - MicroTech III Unit Controller for Water Source Heat Pumps (LONWORKS).

The I/O Expansion Module is a field-installed option. It is an extension of the MicroTech III unit controller and provides extra functionality.

The I/O Expansion Module has 4 main purposes:

- The MicroTech III unit controller in combination with the I/O Expansion Module will be the standard control system for two-stage Water Source Heat Pump equipment. (i.e. large vertical units).
- The I/O Expansion Module has outputs to control electric heat on a standard Water Source Heat Pump.
- The I/O Expansion Module has outputs for multi-speed fans on a standard Water Source Heat Pump.
- The I/O Expansion Module has an independent LED annunciator to identify operational fault conditions on second stage equipment.

Figure 13: I/O Expansion Module Configuration Jumper Terminals

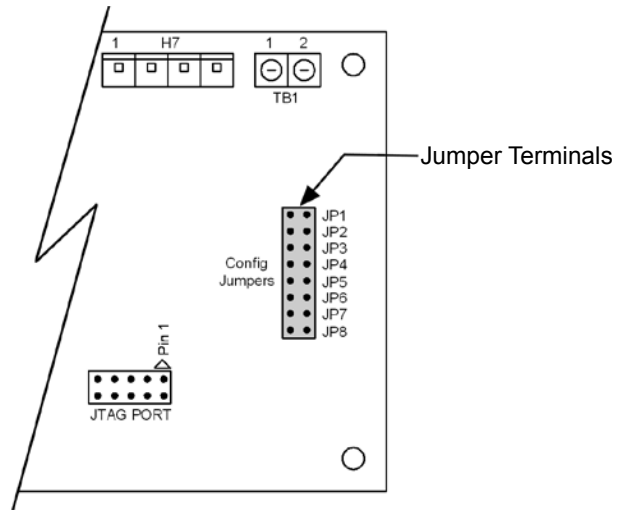

Features

Standard Heat Pumps / Single Circuit Units

- Monitors entering water temperature for boilerless electric heat control
- Outputs for medium and high speed fan controls.

Table 12: I/O Expansion Module Jumper Settings

I/O Expansion Description	Jumper(s)	Jumper Setting		Model
Compressor Options	JP1	JP1	Open	Single Compressor Model (factory default setting)
		JP1	Shorted	Dual Compressor Model
Hot Gas/Water Reheat (HGR) Dehumidification	JP2	JP2	Open	None (default)
		JP2	Shorted	Hot Gas / Water Reheat (HGR)
Secondary Heating Options*	JP3 & JP4	JP3	Open	None
		JP4	Open	
		JP3	Open	Boilerless Electric Heat
		JP4	Shorted	
Fan Speed Selection	JP5 & JP6	JP5	Open	Single Speed Fan (PSC motor)
		JP6	Open	
		JP5	Shorted	Two-Speed Fan (EC motor)*
		JP6	Open	
		JP5	Open	Three-Speed Fan*
		JP6	Shorted	
Not Used	JP7	JP7	Open	–
Lead Compressor Option	JP8	JP8	Open	Compressor #1 is Lead (factory default setting)
		JP8	Shorted	Compressor #2 is Lead (Valid for Dual Compressor Models Only)

* Available with secondary heating options in addition to EC motor.

Table 13: I/O Expansion Module LED & Fault Outputs

Description	Type	Yellow	Green	Red
Invalid Jumper Configuration	Fault	Flash	Flash	OFF
Baseboard Communication Fail	Fault	OFF	Flash	Flash
Entering Water Temp Sensor Fail (with Boilerless Electric Heating)	Fault	Flash	Flash	ON
Service Test Mode Enabled	Mode	Flash	Flash	Flash
Unoccupied Mode	Mode	ON	ON	OFF
Occupied, Bypass, Standby, or Tenant Override Modes	Mode	OFF	ON	OFF

Note: Mode / Faults are listed in order of priority.
I/O Expansion module supplied with EC motor, and Boilerless Heat options.

MicroTech III Controller With LONWORKS® Communication Module

This manual covers the installation of a Daikin Vertical Floor Unit - Model VFC, VFW Water Source Heat Pump. For installation and operation information on LONWORKS Communication Module and other ancillary control components, see:

- IM 927 - MicroTech III Water Source Heat Pump LonWorks Communication Module
- IM 933 - LonMaker Integration Plug-in Tool: For use with the MicroTech III Unit Controller
- IM 955 - MicroTech III Wall Sensor for use with Microtech III Unit Controller

Figure 14: LONWORKS Communication Module

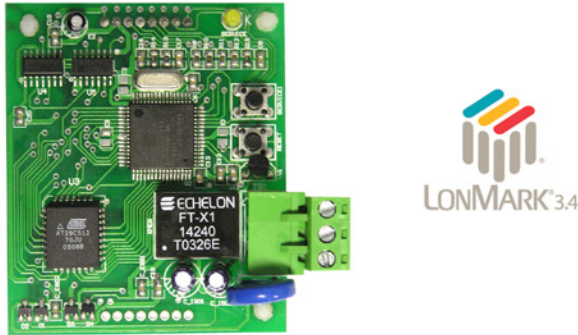

The LONWORKS communication module will plug into the Microtech III unit controller at the CN_LON1 Header (see Figure 16 on page 20).

Each Daikin water source heat pump can be equipped with a LONWORKS communication module. The controller is microprocessor-based and is designed to communicate over a LONWORKS communications network. The unit controller is factory programmed and tested with all the logic required to monitor and control the unit. The wall thermostat sets the unit mode of operation. The unit controller monitors water and air temperatures, and can communicate fault conditions to a LONWORKS communications network.

The MicroTech III unit controller with communication module includes a unit-mounted return air, discharge air and leaving water temperature sensor. Wall mounted temperature sensors include setpoint adjustment and tenant override. The user has the capability of substituting the wall sensor with a duct-mounted return air sensor.

Each unit controller orchestrates the following unit operations:

- Enable heating and cooling to maintain setpoint based on a room sensor.
- Enable fan and compressor operation.
- Monitor all equipment protection controls.
- Monitor discharge air temperature.
- Monitor leaving water temperature.
- Relay status of all vital unit functions.
- Support optional control outputs.

MicroTech III heat pumps with a MicroTech III unit controller are LONMARK certified and designed to be linked with a centralized building automation system through a LONWORKS communications network for centralized scheduling and management of multiple heat pumps. Wall-mounted room sensors are available to control the heating and cooling operation of each MicroTech III Water Source Heat Pump Unit Controller. Available room sensors include: room sensor with LED status and tenant override button, room sensor with LED status, timed-override button, room sensor with LED status, timed-override button, and setpoint adjustment, and room sensor with LED status, timed-override button, setpoint adjustment.

The MicroTech III water source heat pump unit controller provides control of Daikin water source heat pumps. The controller enables the mode of operation, monitors the water and air temperatures, and indicates fault conditions. Each unit controller is factory programmed, wired, and tested for effective operation of your Daikin water source heat pump.

The MicroTech III water source heat pump controller uses LONWORKS technology.

LONMARK® 3.4 certified application code is the current standard application code for MicroTech III units.

MicroTech III Controller with BACnet Communication Module

For installation and operation information on MicroTech III unit controller and other ancillary components, see:

- IM 928 - MicroTech III BACnet Communication Module
- OM 931 - MicroTech III Unit Controller for Water Source Heat Pumps Operation and Maintenance Manual
- IM 955 - MicroTech III Wall Sensor For use with Microtech III Unit Controller

Daikin water source heat pumps are available with a BACnet MS/TP communication module that is designed to communicate over a BACnet MS/TP communications network to a building automation system (BAS). It can be factory or field-installed.

The unit controller is programmed and tested with all the logic required to monitor and control the unit. An optional wall sensor may be used with the communication module to provide limited local control of the water source heat pump. The unit controller monitors water and air temperatures and passes information to the communication module. The module communicates with the BAS, to provide network control of the water source heat pump.

The module makes operational data and commands available on a communications network using BACnet objects and properties:

- The network cable is a shielded twisted-pair cable Network communications run up to 76.8 Kbps
- DIP switches on the controller enable the MS/TP MAC address to be set in the range 0-127
- Four green status LEDs on the communication module indicate communication activity on the MS/TP communication network and with the unit controller

Figure 15: MicroTech III BACnet Water Source Heat Pump Snap-in Communication Module

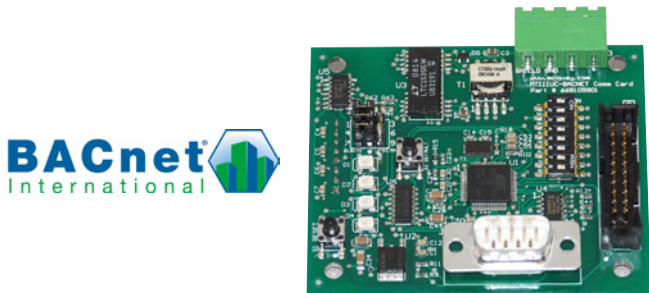

MicroTech III Unit Controller with BACnet MS/TP Communication Module orchestrates the following unit operations:

- Enable heating and cooling to maintain setpoint based on a room sensor
- Enable fan and compressor operation
- Monitors all equipment protection controls
- Monitors room and discharge air temperatures
- Monitors leaving water temperature
- Relays status of all vital unit functions

The MicroTech III unit controller with communication module includes:

- Return Air Temperature sensor (RAT)(field-installed)
- Discharge Air Temperature sensor (DAT)(field-installed)
- Leaving Water Temperature sensor (LWT) (factory installed)

Note: Refer to IM 956 for details to install (RAT) & (DAT) sensors.

⚠ **CAUTION**

When an optional wall-mounted room temperature sensor is connected to the unit controller, the Return Air Temperature (RAT) sensor must not be installed. A wall-mounted room temperature sensor and the return air temperature sensor must not be connected simultaneously or the unit will not operate properly.

The communication module provides access to setpoints for operational control

Available wall sensors include:

- Room sensor with LED status and tenant override button
- Room sensor with LED status, tenant override button, and $\pm 3^{\circ}\text{F}$ setpoint adjustment
- Room sensor with LED status, tenant override button, 55° to 95°F setpoint adjustment

Figure 16: LONWorks Communication Module Placement on MicroTech III Unit Controller

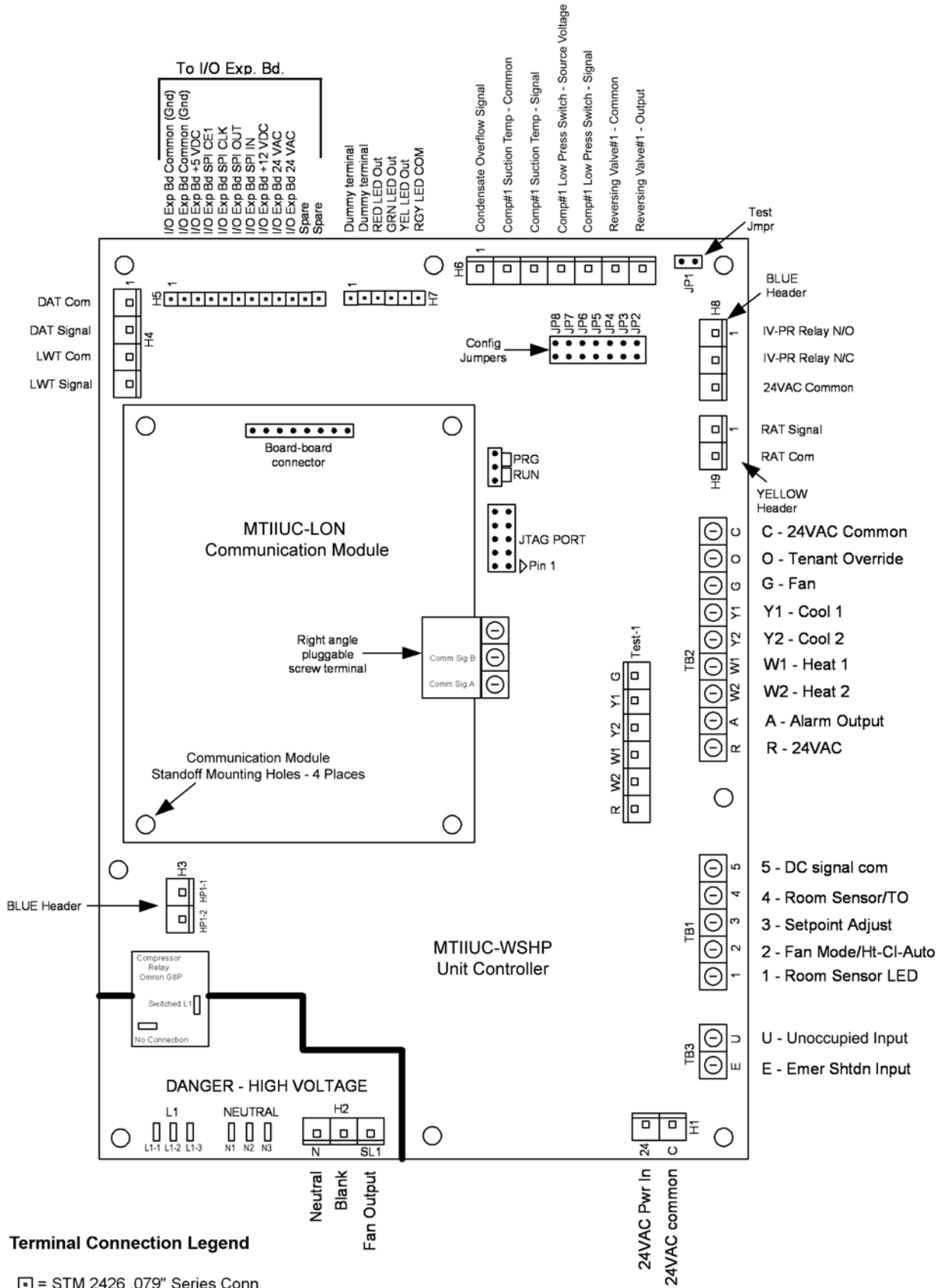

Terminal Connection Legend

- ◻ = STM 2426 .079" Series Conn
- ◻ = STM 24183 .156" Series Conn
- ⊖ = 45 Deg Brd Mtd Screw terminal
- ◻ = 1/4" Quick Connect terminal
- ◻ = 0.025" square post, board-board header/receptacle or jumper assy

Changing PSC Fan Motor Speed

The fan motor can be changed from high to low speed or vice versa by interchanging the wires on the black and red labeled terminals on the motor terminal block.

⚠ WARNING



Hazardous Voltage!
The installer must determine and follow all applicable codes and regulations. This equipment presents hazards of electricity, rotating parts, sharp edges, heat and weight. Failure to read and follow these instructions can result in property damage, severe personal injury or death.

⚠ CAUTION

Sharp edges can cause personal injury. Avoid contact with them.

Unit Sizes 009 and 012 (all available voltages)

Fan motors on unit sizes 009 and 012 (all available voltages) are factory wired for low. To change between low and high speed, interchange the red and black wires.

Figure 17: Sizes 009 and 012 (all available voltages)

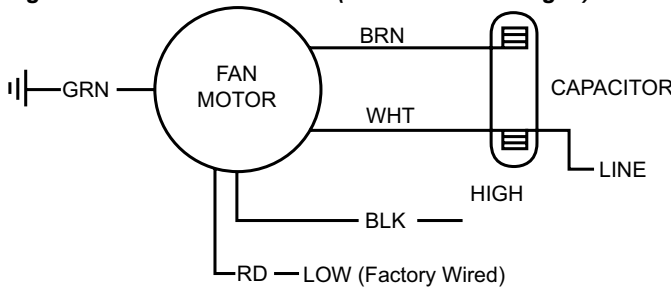

Unit Sizes 015 and 019 (all available voltages)

Fan motors on unit sizes 015 and 019 in all available voltages have a four-position terminal block and are factory wired for low speed (Figure 18). To change between low and high speed, interchange the red and black wires.

Figure 18: Sizes 015 through 024 (all available voltages)

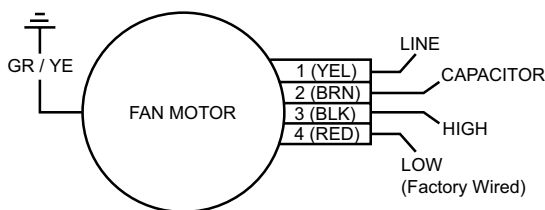

Unit Sizes 024, 030 and 036 (all available voltages)

Fan motors on unit sizes 024, 030, 036 in all available voltages have a four-position terminal block and are factory wired for high speed (Figure 19). To change between high and low speed, interchange the red and black wires.

Figure 19: Sizes 024, 030, 036 factory wired for high speed

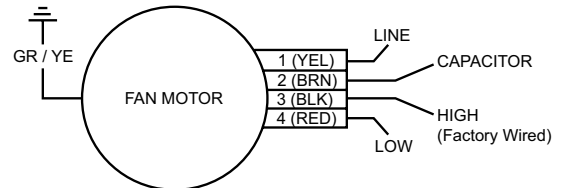

Unit Sizes 042, 048, 060 and 070 (208-230/60/1 and 208-230/60/3)

The fan motor on unit sizes 042, 048, 060 and 070 for voltages 208-230/60/1 and 208-230/60/3 has a five-position terminal block and is factory wired for high speed (Figure 20). Low speed can be achieved by interchanging black terminal (3) with red terminal (5) and the black and blue terminals (3 & 4) receive a jumper as shown in Figure 21.

Figure 20: Size 042, 048, 060 and 070 (208-230/60/1 and 208-230/60/3) factory wired for high speed

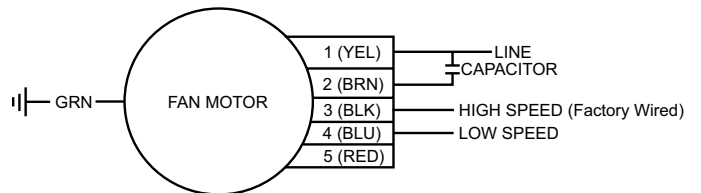
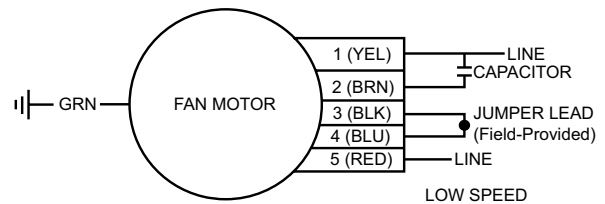

Figure 21: Size 042, 048, 060 and 070 (208-230/60/1 and 208-230/60/3) low speed



Unit Sizes 042, 048, 060 and 070 (575/60/3)

The fan motor on unit sizes 042, 048, 060, and 070 for voltage 575/60/3 has a five-position terminal block and are factory wired for high speed (Figure 22). Low speed can be achieved by interchanging black terminal (3) with red terminal (5) and the black and blue terminals (3 & 4) receive a jumper as shown in Figure 23.

Note: Jumper lead is field-provided

Figure 22: Size 042, 048, 060, 070 (575/60/3) factory wired for high speed

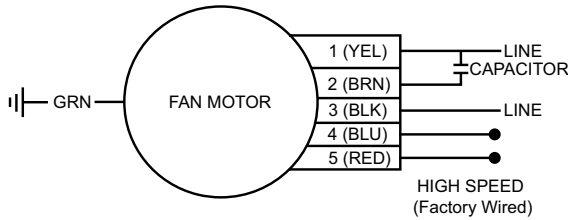
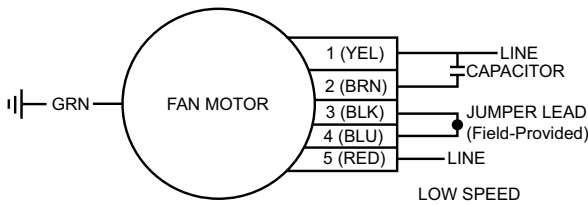

Figure 23: Size 042, 048, 060, 070 (575/60/3) low speed



Unit Sizes 042, 048, 060 and 070 (380/50/3 and 460/60/3)

The fan motor on unit sizes 042, 048, 060, and 070 for voltage 380/50/3 and 460/60/3 have a five-position terminal block and are factory wired for high speed (Figure 24). Low speed can be achieved by interchanging black terminal (3) with red terminal (5) and the black and blue terminals (3 & 4) receive a jumper as shown in Figure 25.

Note: Jumper lead is field-provided

Figure 24: Size 042, 048, 060, 070 (380/50/3 and 460/60/3) factory wired for high speed

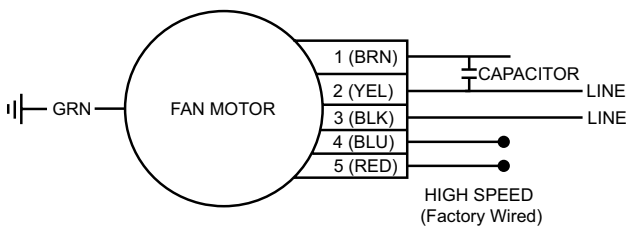
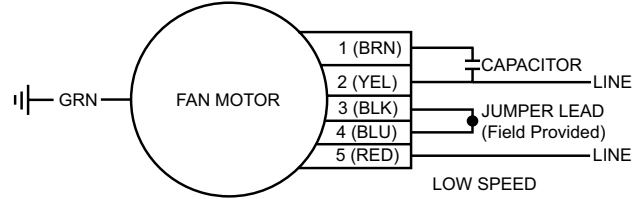

Figure 25: Size 042, 048, 060, 070 (380/50/3 and 460/60/3) low speed



Notes: All motors have a wiring label that is keyed for proper wiring operation. Check unit wiring diagram (on electrical access panel) for proper unit operation. Not all labels are the same. Units leaving the factory are wired for high or low fan speed. Jumper lead is field-provided. Label is located on the back of the terminal block.

(Optional) EC Motor

The EC motor will maintain the rated airflow as static pressure increases or decreases within the unit's operating range.

⚠ CAUTION

Units must be checked for water leaks upon initial water system start-up. Water leaks may be a result of mishandling or damage during shipping. Failure by the installing contractor to check for leaks upon start-up of the water system could result in property damage.

1. Open all valves to full open position and turn on power to the unit.
2. Set the thermostat for "Fan Only" operation by selecting "Off" at the system switch and "On" at the fan switch. If "Auto" fan operation is selected, the fan will cycle with the compressor.
3. For those units that have two-speed motors, reconnect for low speed operation if necessary
4. Set thermostat to "Cool." If the thermostat is an automatic changeover type, simply set the cooling temperature to the lowest temperature. On manual changeover types, additionally select "Cool" at the system switch.
 Again, many units have time delays help protect the compressor(s) against short cycling.
 After a few minutes of operation, check the discharge grilles for cool air delivery. Measure the temperature difference between entering and leaving water. It should be approximately 1-1/2 times greater than the heating mode temperature difference. For example, if the cooling temperature difference is 15°F (8°C), the heating temperature difference should be 10°F (5°C).
 Without automatic flow control valves, target a cooling temperature difference of 10°F to 14°F (5°C to 8°C). Adjust the combination shutoff/balancing valve in the return line to a water flow rate which will result in the 10°F to 14°F (5°C to 8°C) difference.
5. Set thermostat to "Heat." If the thermostat is the automatic changeover type, set system switch to the "Auto" position and depress the heat setting to the highest temperature. Some units have built-in time delays which prevent the compressor from

immediately starting. With most control schemes, the fan will start immediately. After a few minutes of compressor operation, check for warm air delivery at discharge grille. If this is a "cold building" start-up, leave unit running until return air to the unit is at least 65°F (18°C).

Measure the temperature difference between entering and leaving air and entering and leaving water. With entering water of 60°F to 80°F (16°C to 27°C), leaving water should be 6°F to 12°F (3.3°C to 6.6°C) cooler, and the air temperature rise through the machine should not exceed 35°F (19°C). If the air temperature exceeds 35°F (19°C), then the water flow rate is inadequate.

6. Check the elevation and cleanliness of the condensate line. If the air is too dry for sufficient dehumidification, slowly pour enough water into the condensate pan to ensure proper drainage.
7. If the conditioner does not operate, check the following points:
 - a. Is supply voltage to the machine compatible?
 - b. Is thermostat type appropriate?
 - c. Is thermostat wiring correct?
8. If the conditioner operates but stops after a brief period:
 - a. Is there proper airflow? Check for dirty filter, incorrect fan rotation (3-phase fan motors only), or incorrect ductwork.
 - b. Is there proper water flow rate within temperature limits? Check water balancing; backflush unit if dirt-clogged.
9. Check for vibrating refrigerant piping, fan wheels, etc.
10. Do not lubricate the fan motor during the first year of operation as it is pre-lubricated at the factory.
11. Field supplied relays installed on the input terminals W1, W2, Y1, Y2 or G may introduce electrical noise. Never install relay coils in series with the inputs.

MicroTech III Unit Controller (Standalone) – 208/230/460/575/60Hz/3-Phase

Drawing No. 668991201

Shown with optional desuperheater pump wiring.

Wiring diagrams are typical. For the latest drawing version refer to the wiring diagram located on the inside of the controls access panel of the unit.

Legend

Item	Description
C1	Capacitor-Compressor
C2	Capacitor-Fan
CC	Compressor - Contactor
CM	Compressor - Motor
COS	Condensate Overflow Sensor
DAT	Discharge Air Temp Sensor
EWT	Entering Water Temp Sensor
HP	High Pressure Switch
ISO-NC	Isolation Valve - Normally Closed
ISO-NO	Isolation Valve - Normally Open
DSHP	Desuperheater Pump
DISC	Non-Fused Disconnect Switch
LED1	LED Annunciator / Harness
LP	Low Pressure Switch
SLTS	Suction Line Temp Sensor
LWT	Leaving Water Temp Sensor
MIII	MicroTech III Main Board
R1	Relay - Fan Motor
RAT	Return Air Temp Sensor
RV	Reversing Valve Solenoid
X1	Transformer
—	Standard Unit Wiring
- - -	Factory Installed Options

Table B

208V	RED
230V	ORG
380V	BLK/RED
460V	BLK/RED
575V	BLACK

Notes:

- Main Board Jumpers:
JP3 - Geothermal
 - I/O Expansion Board Jumpers:
JP2 - HGRH
JP3 - Supplemental EH
JP4 - Boilerless EH
JP5 - 2-Speed Fan
- 3 Transformer:
Unused wire to be capped.
- 4 Desuperheater only available on
115-208-230V applications.

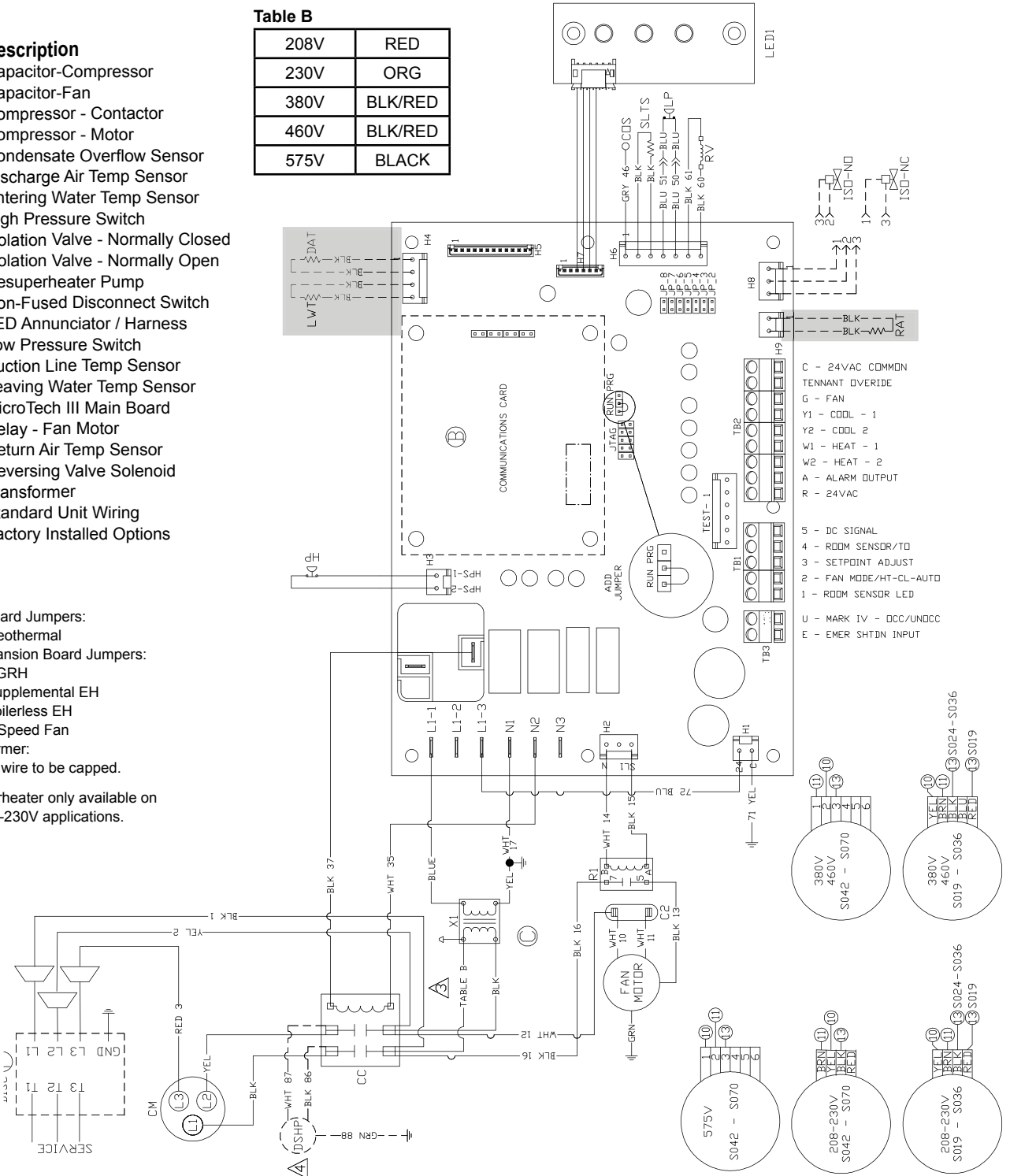

Note: Gray tinted areas in the wiring diagram: Units with factory installed communication module include Discharge Air Temperature (DAT) and Return Air Temperature (RAT) sensors shipped loose and are field installed. The Leaving Water Temperature (LWT) sensor is factory installed. Entering Water Temperature (EWT) sensor is factory installed on units with Electric Heat.

MicroTech III Unit Controller with Optional ECM Motor, Desuperheater and I/O Expansion Module – 208/230/60 Hz/1-Phase

Drawing No. 668991501

Wiring diagrams are typical. For the latest drawing version refer to the wiring diagram located on the inside of the controls access panel of the unit.

Legend

Item	Description
C1	Capacitor-Compressor
CC	Compressor - Contactor
CM	Compressor - Motor
COS	Condensate Overflow Sensor
DAT	Discharge Air Temp Sensor
DISC	Non-Fused Disconnect Switch
DSHP	Desuperheater Pump
HP	High Pressure Switch
IOEXP	IO Expansion Board / Harness
ISO-NC	Isolation Valve - Normally Closed
ISO-NO	Isolation Valve - Normally Open
LED1	LED Annunciator / Harness
LED2	LED Annunciator / Harness
LP	Low Pressure Switch
LWT	Leaving Water Temp Sensor
MIII	MicroTech III Main Board
P1	24VAC Supply IO Expansion Board
RAT	Return Air Temp Sensor
RV	Reversing Valve Solenoid
SLTS	Suction Line Temp Sensor
X1	Transformer
—	Standard Unit Wiring
---	Factory Installed Options

Notes:



- Main Board Jumpers:
 - JP3 - Geothermal
 - I/O Expansion Board Jumpers:
 - JP2 - HGRH
 - JP3 - Supplemental EH
 - JP4 - Boilerless EH
 - JP5 - 2-Speed Fan
-  Transformer:
 Unused wire to be capped.
-  Desuperheater only available on 115-208-230V applications.

Table B

208V	RED
230V	ORG

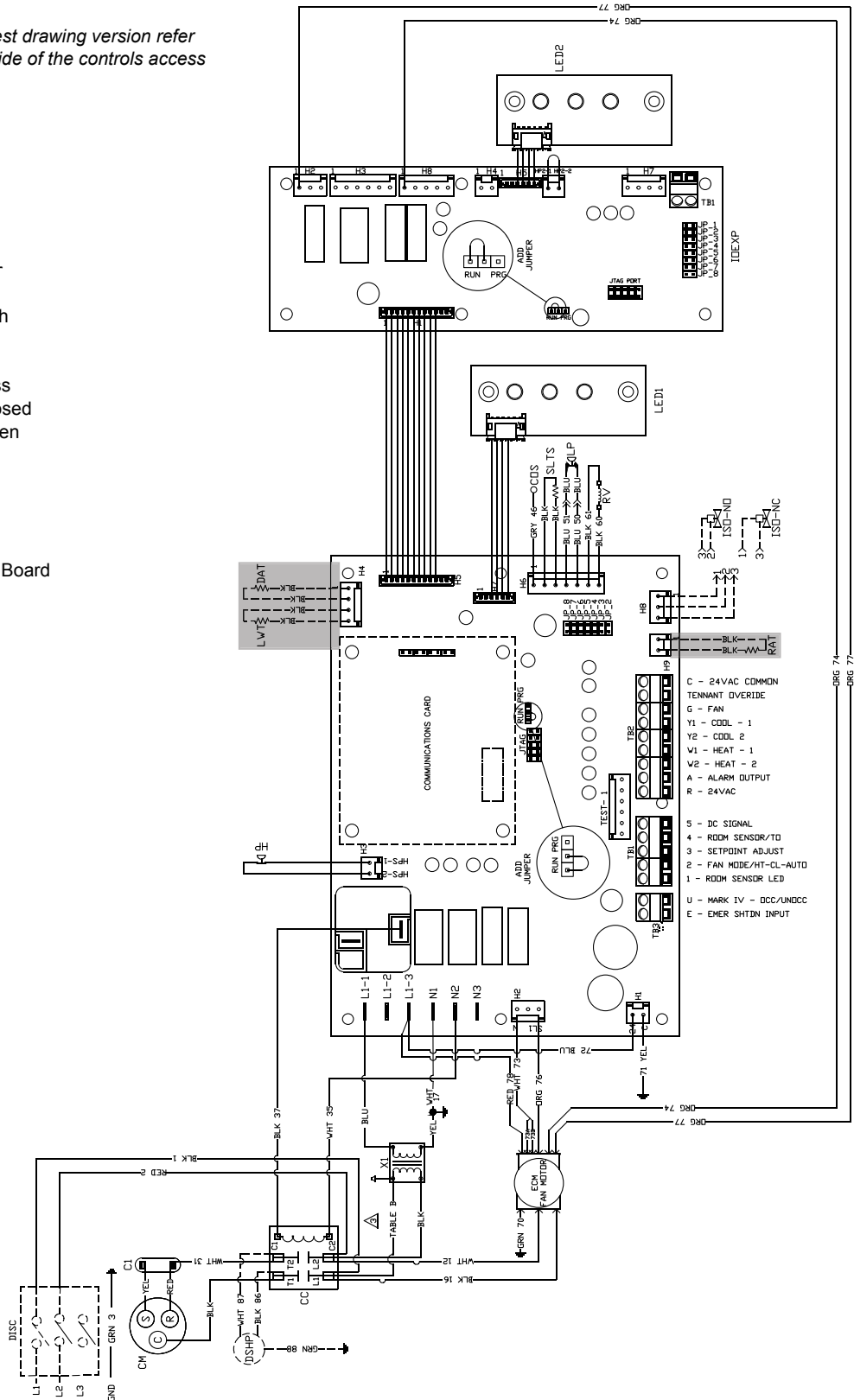

Note: Gray tinted areas in the wiring diagram: Units with factory installed communication module include Discharge Air Temperature (DAT) and Return Air Temperature (RAT) sensors shipped loose and are field installed. The Leaving Water Temperature (LWT) sensor is factory installed. Entering Water Temperature (EWT) sensor is factory installed on units with Electric Heat.

MicroTech III Unit Controller with Optional ECM Motor, Desuperheater, Electric Heat Coil and I/O Expansion Module – 208/230/60 Hz/3-Phase

Drawing No. 668991301

Wiring diagrams are typical. For the latest drawing version refer to the wiring diagram located on the inside of the controls access panel of the unit.

Legend

Item	Description
CC	Compressor - Contactor
CM	Compressor - Motor
COS	Condensate Overflow Sensor
DAT	Discharge Air Temp Sensor
EWT	Entering Water Temp Sensor
HP	High Pressure Switch
HTR	Electric Heater Cartridge
IOEXP	IO Expansion Board / Harness
ISO-NC	Isolation Valve - Normally Closed
ISO-NO	Isolation Valve - Normally Open
DSHP	Desuperheater Pump
LED1	LED Annunciator / Harness
LED2	LED Annunciator / Harness
LP	Low Pressure Switch
SLTS	Suction Line Temp Sensor
LWT	Leaving Water Temp Sensor
MIII	MicroTech III Main Board
RAT	Return Air Temp Sensor
RV	Reversing Valve Solenoid
TB1	Power Terminal Block
X1	Primary 24VAC Transformer
—	Standard Unit Wiring
- - -	Factory Installed Options

Notes:

- Main Board Jumpers:
JP3 - Geothermal
 - I/O Expansion Board Jumpers:
JP2 - HGRH
JP3 - Supplemental EH
JP4 - Boilerless EH
JP5 - 2-Speed Fan
- ⚠ Transformer:
Unused wire to be capped.
- ⚠ Desuperheater only available on 115-208-230V applications.

Table B

208V	RED
230V	ORG

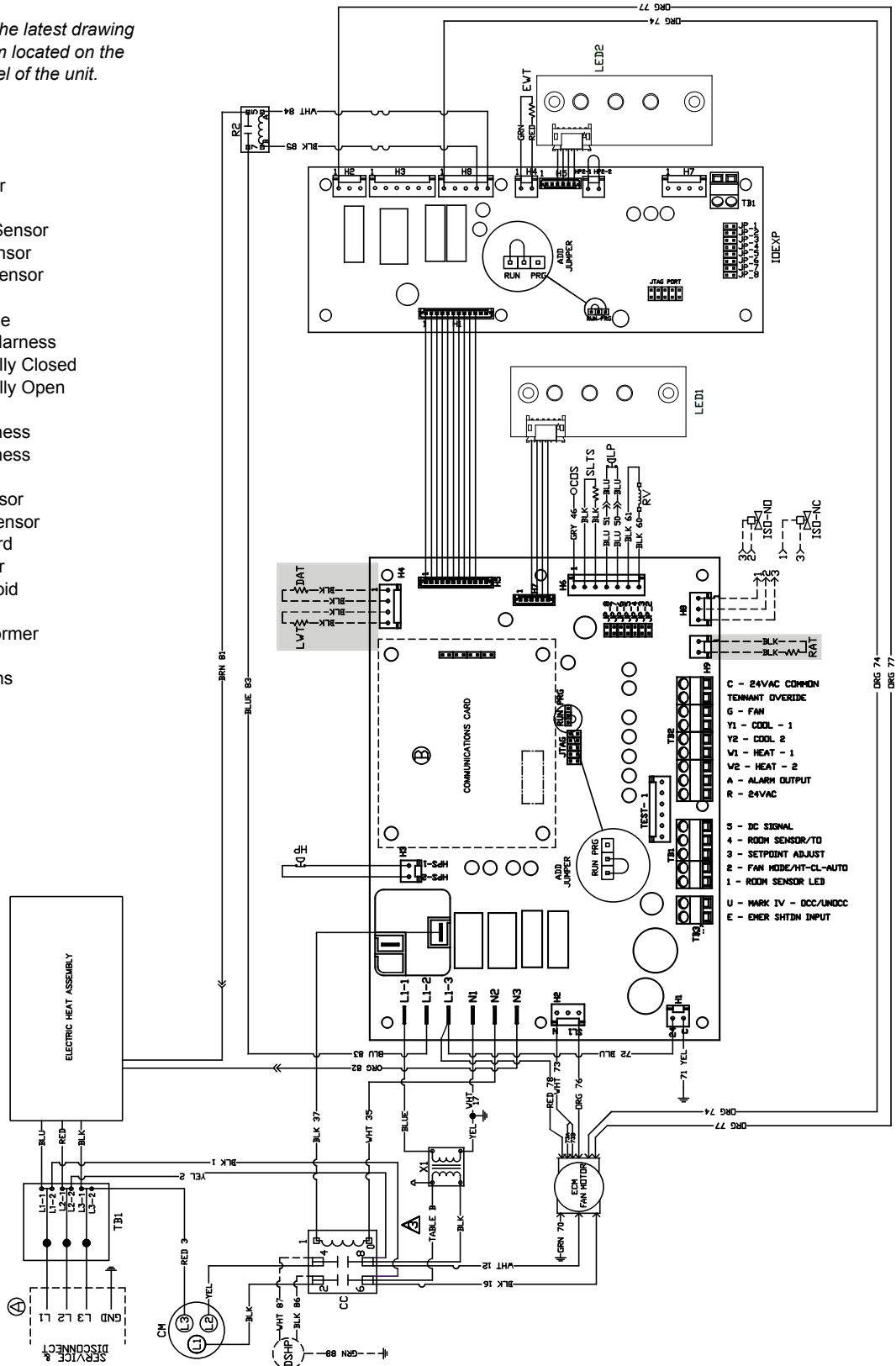

Note: Gray tinted areas in the wiring diagram: Units with factory installed communication module include Discharge Air Temperature (DAT) and Return Air Temperature (RAT) sensors shipped loose and are field installed. The Leaving Water Temperature (LWT) sensor is factory installed. Entering Water Temperature (EWT) sensor is factory installed on units with Electric Heat.

MicroTech III Unit Controller with Optional ECM Motor, Desuperheater, and I/O Expansion Module 208/230/60/3-Phase

Drawing No. 668991401

Wiring diagrams are typical. For the latest drawing version refer to the wiring diagram located on the inside of the controls access panel of the unit.

Legend

Item	Description
CC	Compressor - Contactor
CM	Compressor - Motor
COS	Condensate Overflow Sensor
HP	High Pressure Switch
HTR	Electric Heater Cartridge
IOEXP	IO Expansion Board / Harness
ISO-NC	Isolation Valve - Normally Closed
ISO-NO	Isolation Valve - Normally Open
DSHP	Desuperheater Pump
DISC	Non-Fused Disconnect Switch
LED1	LED Annunciator / Harness
LED2	LED Annunciator / Harness
LP	Low Pressure Switch
SLTS	Suction Line Temp Sensor
LWT	Leaving Water Temp Sensor
MIII	MicroTech III Main Board
RAT	Return Air Temp Sensor
RV	Reversing Valve Solenoid
X1	Primary 24VAC Transformer
—	Standard Unit Wiring
---	Factory Installed Options

Notes:

- Main Board Jumpers:
JP3 - Geothermal
 - I/O Expansion Board Jumpers:
JP2 - HGRH
JP3 - Supplemental EH
JP4 - Boilerless EH
JP5 - 2-Speed Fan
- ⚠ Transformer:
Unused wire to be capped.
- ⚠ Desuperheater only available on 115-208-230V applications.

Table B

208V	RED
230V	ORG

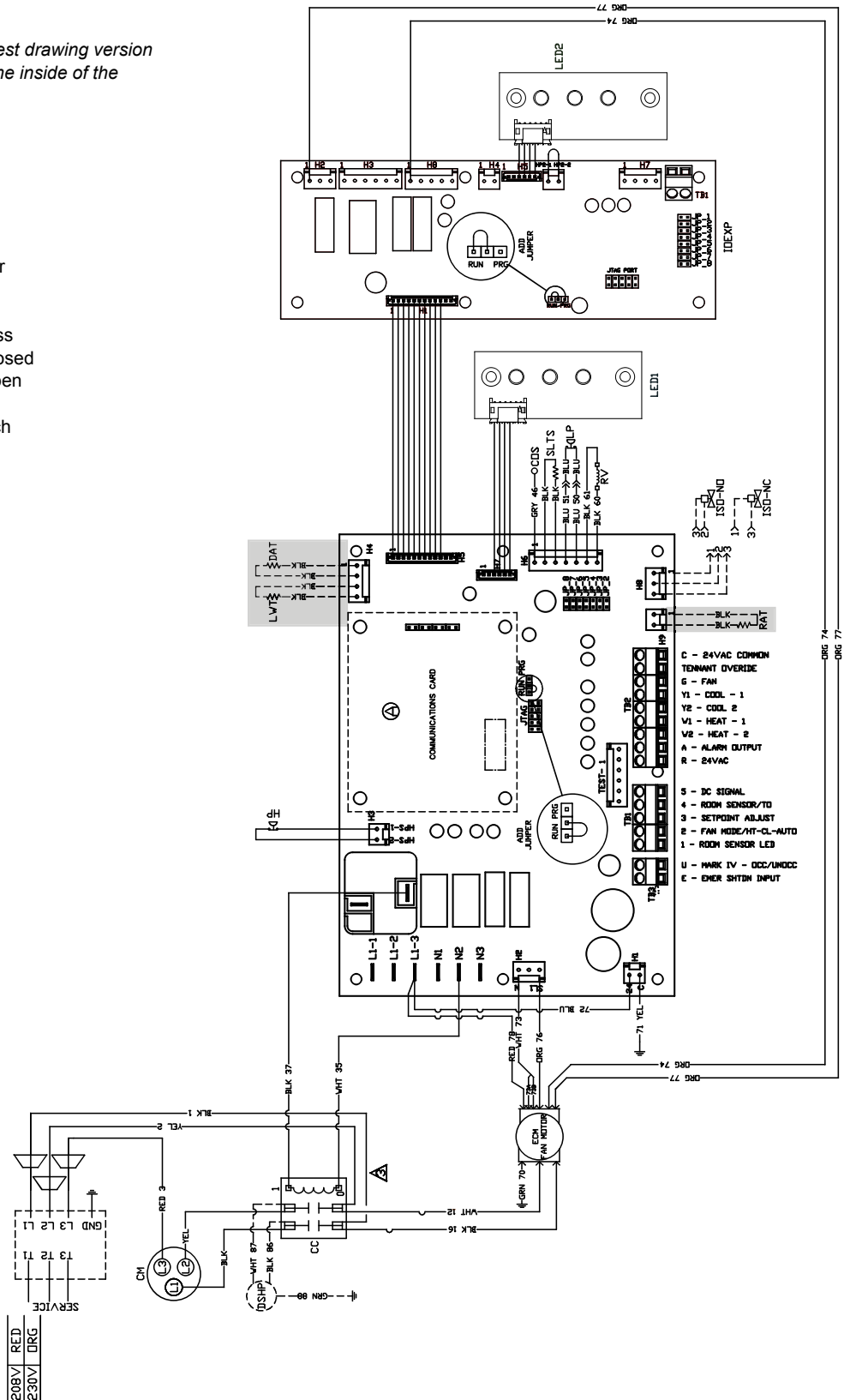

Note: Gray tinted areas in the wiring diagram: Units with factory installed communication module include Discharge Air Temperature (DAT) and Return Air Temperature (RAT) sensors shipped loose and are field installed. The Leaving Water Temperature (LWT) sensor is factory installed.

MicroTech III Unit Controller with PSC Motor, Desuperheater and I/O Expansion Module for Hot Gas Reheat Control (Unit Sizes 019-070) 208/230/60/1-Phase

Drawing No. 669007101A

Wiring diagrams are typical. For the latest drawing version refer to the wiring diagram located on the inside of the controls access panel of the unit.

Legend

Item	Description
C1	Capacitor-Compressor
C2	Capacitor-Fan
CC	Compressor - Contactor
CM	Compressor - Motor
COS	Condensate Overflow Sensor
DAT	Discharge Air Temp Sensor
EWT	Entering Water Temp Sensor
HP	High Pressure Switch
HTR	Electric Heater Cartridge
IOEXP	IO Expansion Board / Harness
ISO-NC	Isolation Valve - Normally Closed
ISO-NO	Isolation Valve - Normally Open
DSHP	Desuperheater Pump
HGRH	3-Way Valve Solenoid
P1	24 VAC Supply I/O Expansion Brd
LED1	LED Annunciator / Harness
LED2	LED Annunciator / Harness
LP	Low Pressure Switch
SLTS	Suction Line Temp Sensor
LWT	Leaving Water Temp Sensor
MIII	MicroTech III Main Board
R1	Relay - Fan Motor
RAT	Return Air Temp Sensor
RV	Reversing Valve Solenoid
X1	Transformer
—	Standard Unit Wiring
- - -	Optional Wiring (by others)

Notes:

- Main Board Jumpers:
JP3 - Geothermal
 - I/O Expansion Board Jumpers:
JP2 - HGRH
JP3 - Supplemental EH
JP4 - Boilerless EH
JP5 - 2-Speed Fan
- Transformer:
Unused wire to be capped.
- Desuperheater only available on 115-208-230V applications.

Table B

208V	RED
230V	ORG

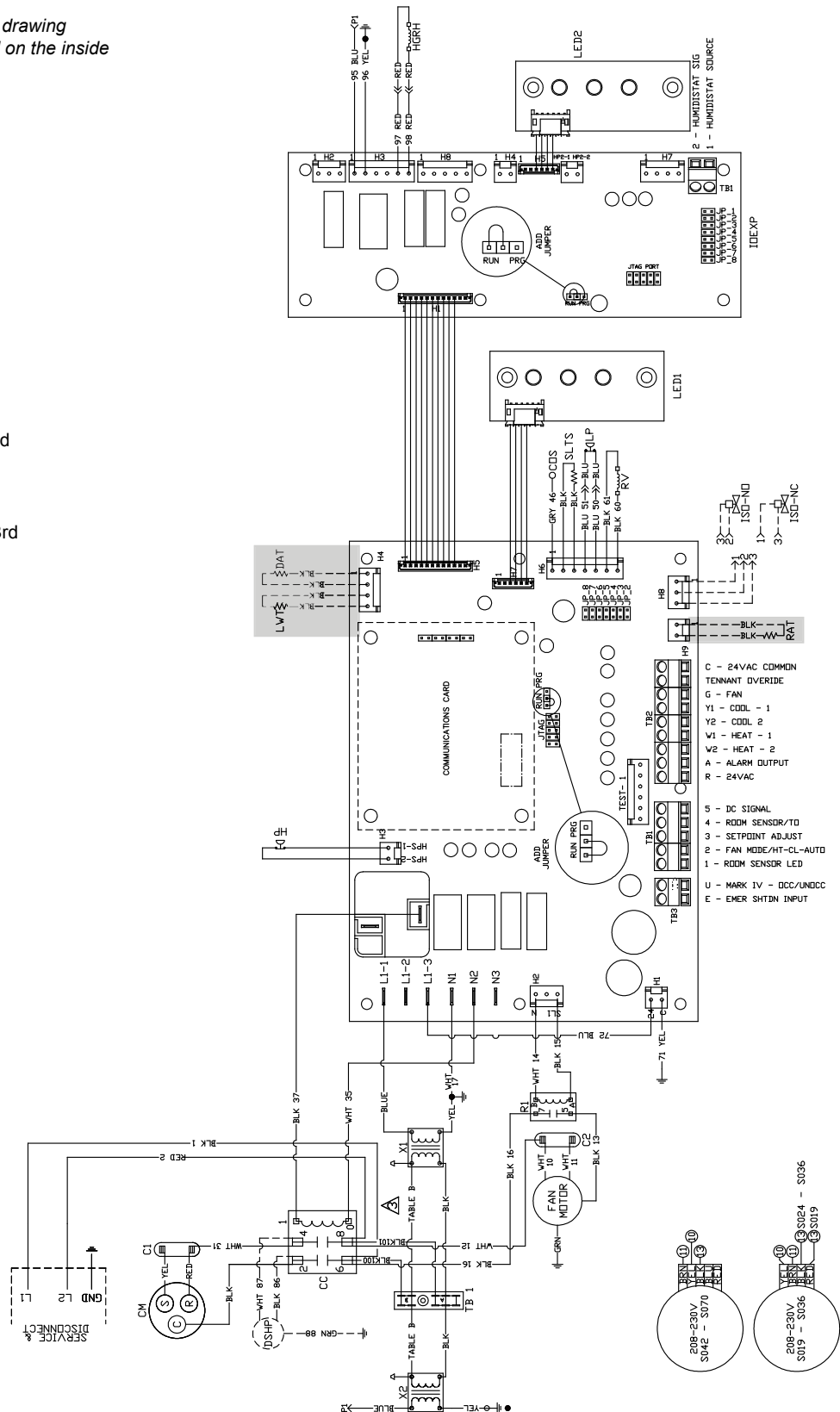

Typical Connections For Thermostats & Temperature Sensors

Thermostats & Remote Sensors Used with MicroTech III –Standalone Operation

Figure 26: Programmable Electronic Thermostat 2 Heat/2 Cool, 7-Day Programmable, Auto Changeover, Hardwired – P/N 910193126 & Wi-Fi P/N 910193131

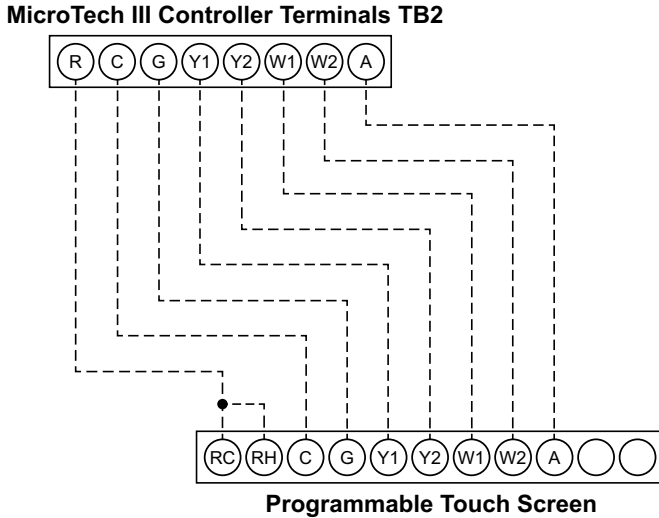

Notes: Includes thermostat and wall plate Refer to IO manual 910193126

Figure 27: Programmable Electronic Thermostat 2 Heat/3 Cool, 7-Day Programmable, Auto Changeover, Hardwired – P/N 910193127 & Wi-Fi P/N 910193132

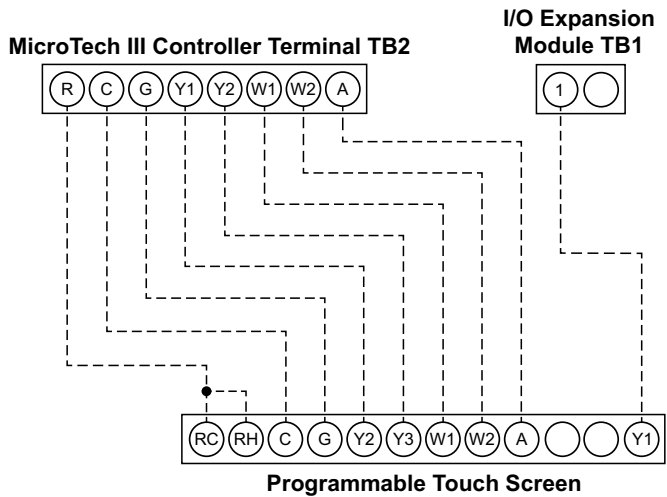

Notes: Includes thermostat and wall plate Refer to IO manual 910193127

Figure 28: Programmable Electronic Thermostat 3 Heat/2 Cool, 7-Day Programmable, Auto Changeover, Hardwired – P/N 910193128 & Wi-Fi P/N 910193133

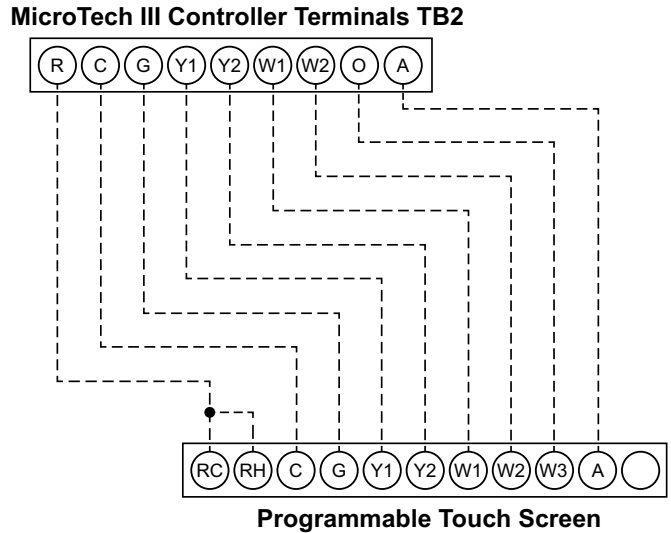

Notes: Includes thermostat and wall plate Refer to IO manual 910193128

Figure 29: Programmable Electronic Thermostat 2 Heat/2 Cool, 7-Day Programmable, Dehumidification, Auto Changeover, Hardwired – P/N 910193129 & Wi-Fi P/N 910193134

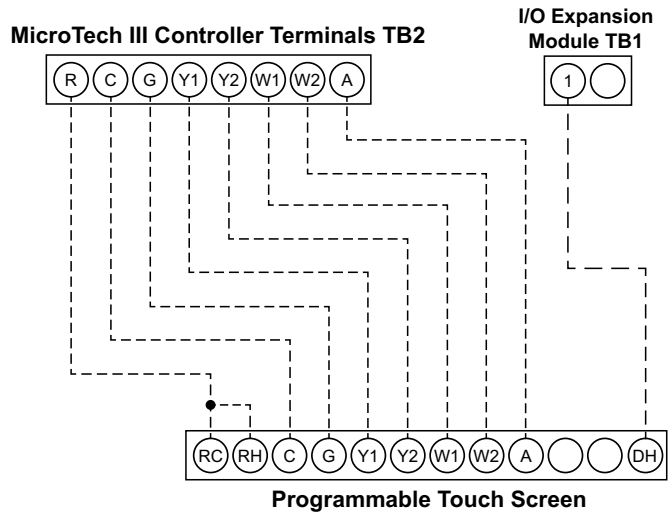

Notes: Includes thermostat and wall plate Refer to IO manual 910193129

Figure 30: Programmable & Non-Programmable Electronic Thermostats 2 Heat/2 Cool, Auto Changeover, Hardwired
 – P/N 910121746 & P/N 910121748

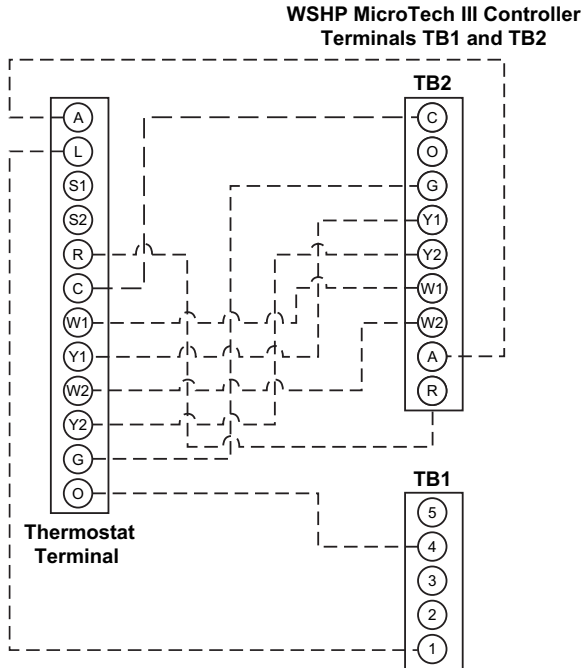

Notes: Includes thermostat and wall plate. Refer to 910121746 or 910121748 Install Manual.

Figure 31: Remote Room Sensor Used With Thermostats 910121746 & 910121748 – P/N 107096010

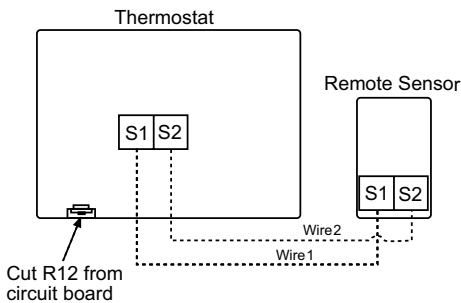
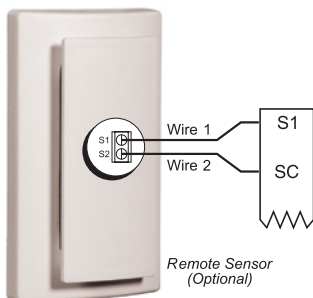

Figure 32: Remote Room Sensor Used With Thermostats 910193126, 910193127, 910193128, 910193129, 910193131, 910193132, 910193133, 910193134 – P/N 667720401



Sensors used with MicroTech III control Building Automated System Operation

Figure 33: Digitally Adjustable Display Sensor (6-button)
 – P/N 910121754

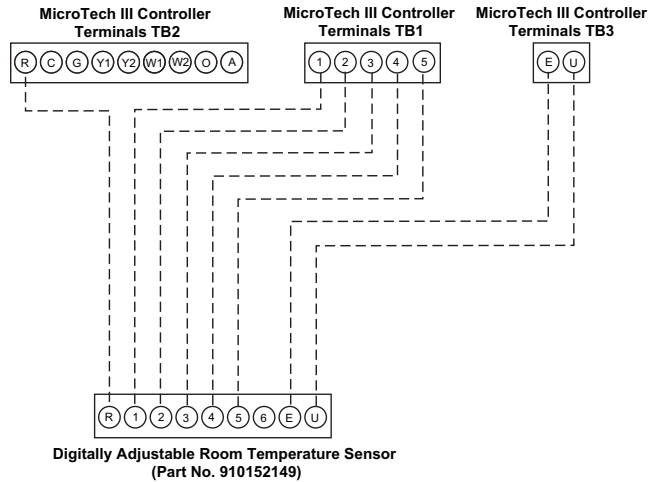

Figure 34: Digitally Adjustable Display Sensor (4-button)
 – P/N 910152147

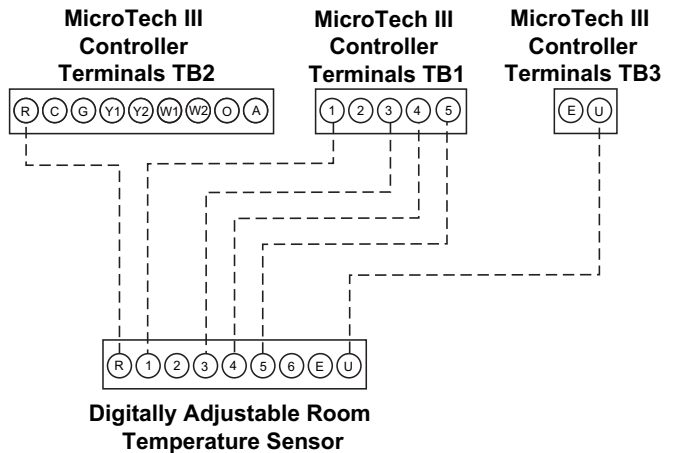

Figure 35: Cool/Warm Adjustable Sensor – P/N 910171464

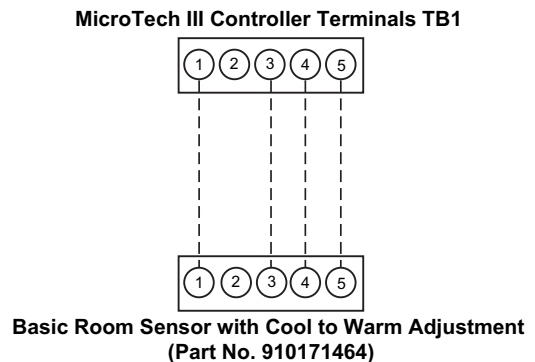

Figure 36: Basic sensor – P/N 910152149

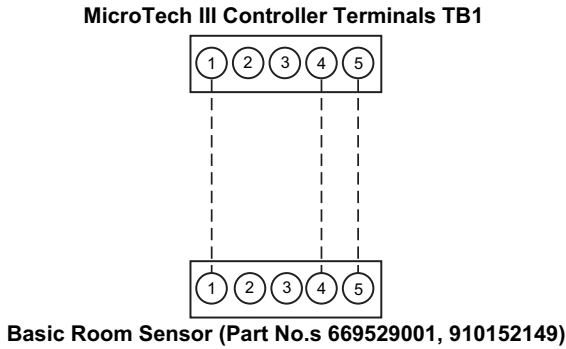

Figure 37: Room sensor with temperature adjustment wiring

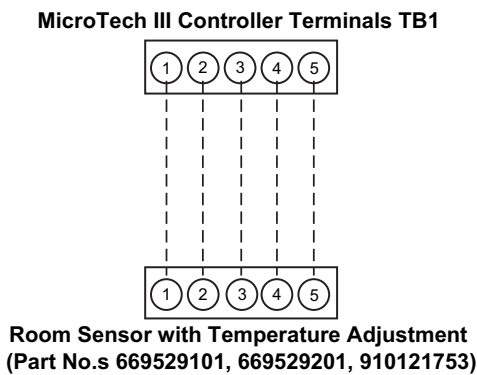

Figure 38: Adjustable Cool/Warm with Occupancy Switch – P/N 910121753

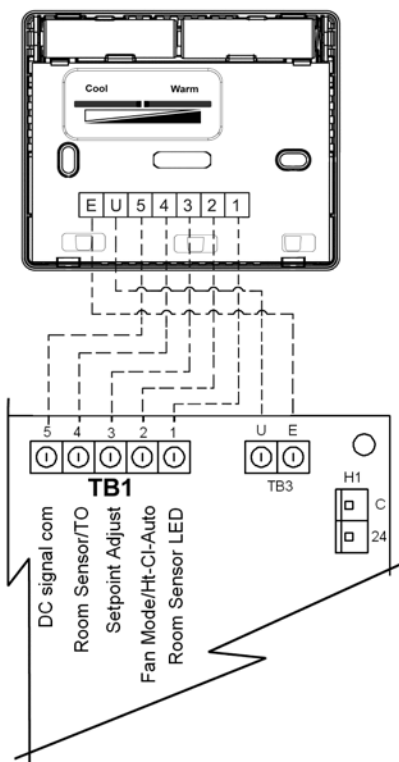

Figure 39: Units equipped with dehumidification and thermostat control. Factory supplied return air sensor connects to H9 terminal.

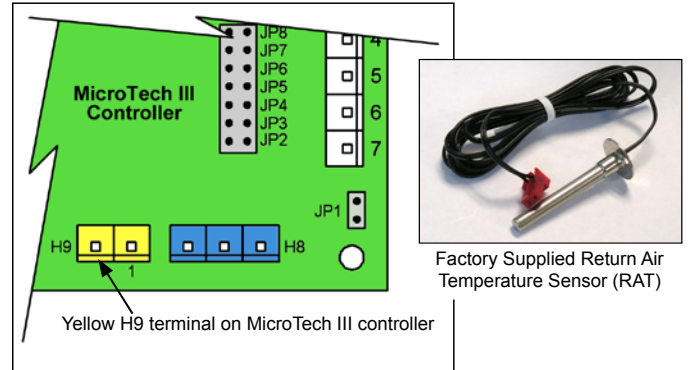
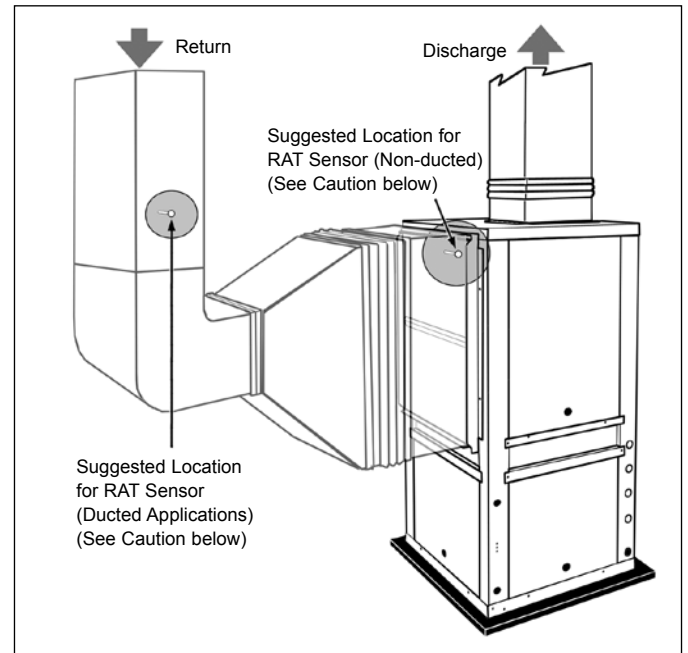

Figure 40: Return Air Temperature Sensor (RAT) locations



CAUTION

When an optional wall-mounted room temperature sensor is connected to the unit controller, the Return Air Temperature (RAT) sensor must not be installed. A wall-mounted room temperature sensor and the return air temperature sensor must not be connected simultaneously or the unit will not operate properly.

Note: For single stage operation wire Y1 from thermostat to Y2 terminal on the Microtech III control board.

Motorized Isolation Valve & Relay

The motorized valve kit is available as a factory-installed and wired option or may be ordered as a field-installed accessory.

Wired as shown in Figure 41, the motorized valve will open on a call for compressor operation. Valves for unit sizes 009 to 019 are 1/2" while unit sizes 024 to 070 are 3/4".

Using a Normally Closed (N/C), power open valve, wire as illustrated in Figure 41.

Figure 41: Normally Closed, Power Open Motorized Valve & Relay Wiring

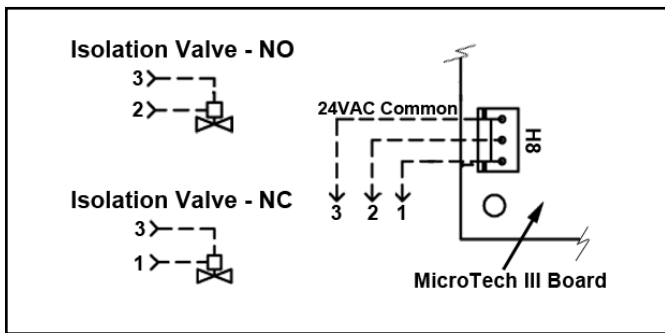
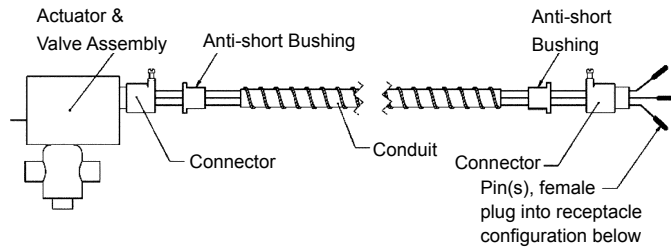

Note: Connectors on valve must be cut off and stripped back and the wires twisted to make connections to the IV/PR Terminals

Pump Restart Relay Kit P/N 061419001

The MicroTech III unit controller has an internal Pump Restart Relay connected to H8, Pin 2 for the Normally Open (N/O) terminal of the internal relay.

Connect to H8, Pin 1 for the Normally Closed (N/C) terminal of the internal relay.

The output of the internal pump restart relay is 24-volts AC and the output is not available when the H8 connection is used to control a motorized valve.

Multiple Unit Control (up to 3 units) (P/N 056794201)

The multiple unit control board is an accessory used when up to 3-units are controlled from a single thermostat. Typically the control panel and board is centrally mounted between the units and thermostat. A maximum of 2 boards may be used together if up to 6-units must be connected and controlled from a single thermostat. For detailed installation instructions refer to IM 952.

This version of the control uses VAC relays and should not be used in combination with any other accessories or equipment that require VDC connections.

Figure 42: Multiple Unit Control Panel and Board

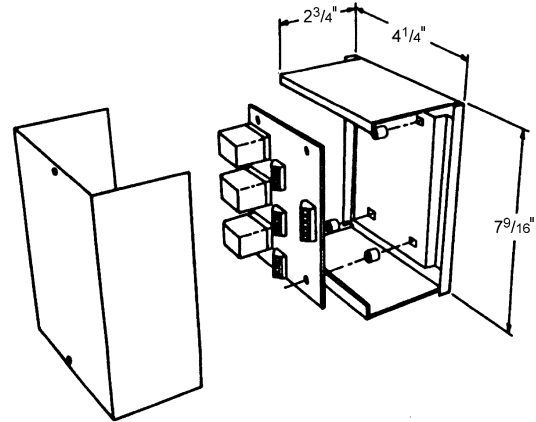

The multiple unit control board provides the components necessary to protect the MicroTech III unit controller from electrical damage that may occur when using standard off-the-shelf relays.

Do not use the unoccupied (U-terminal) feature with the multiple unit control board.

Figure 43: Wiring Multiple Unit Control Board (MUCP)

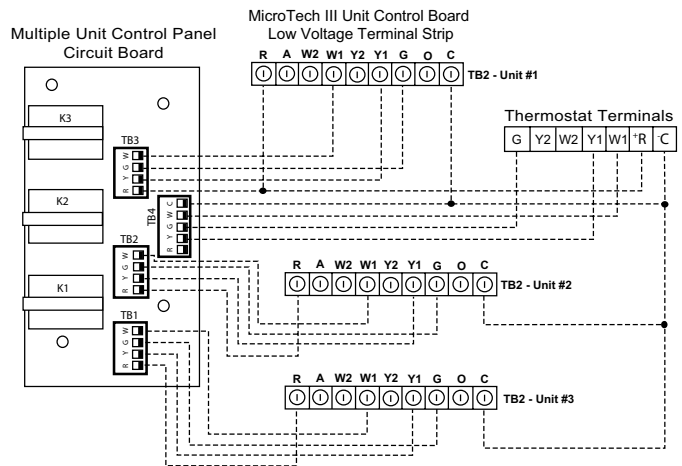

Notes: Dotted lines represent low voltage (Class II) wiring; a color-coded thermostat cable is recommended.

MUCP may be mounted horizontally or vertically on heat pump cabinet or any convenient surface. Do not use if using night setback. Thermostat must be A.C. voltage.

Hot Gas/Water Reheat Dehumidification (Option) (Unit Sizes 019 – 070)

Hot Gas Reheat (HGRH) allows superior humidity control by utilizing a second air coil to provide dehumidification and tempered air to the conditioned space.

A field supplied humidistat is required. Wire the humidistat to the dual terminal block (TB1) on the I/O expansion module.

Note: *Hot Gas Reheat (HGRH) utilizes high fan speed.*

The in and outs of R-410A

R-410A is a non-ozone depleting blend of two refrigerants - HFC-125 and HFC-32 in a fifty percent mixture. R-410A exhibits higher operating pressure and refrigeration capacity than R-22. R-410A is intended for use in new air conditioning applications that have traditionally been used HCFC-22 (R-22). Due to higher capacity and pressure of R-410A, it must not be used in existing R-22 systems.

Although R-410A is non-flammable at ambient temperature and atmospheric pressure, it can become combustible under pressure when mixed with air.

Note: *R-410A should not be mixed with air under pressure for leak testing. Pressure mixtures of dry nitrogen and R-410A can be used for leak testing.*

Lubrication

R-410A should be used only with polyester (POE) oil. The HFC refrigerant components in R-410A will not be compatible with mineral oil or alkylbenzene lubricants. R-410A systems will be charged with the OEM recommended lubricant, ready for use with R-410A.

Charging

Due to the zeotropic nature of R-410A, it should be charged as a liquid. In situations where vapor is normally charged into a system, a valve should be installed in the charging line to flash the liquid to vapor while charging.

Make certain that the recycle or recovery equipment used is designed for R-410A. The pressure of R-410A refrigerant is approximately 60 percent greater than that of R-22. Pressure gauges require a range up to 800 PSIG high side and 250 PSIG low side. Recovery cylinders require a 400 PSIG rating – do not put R-410A in a 300 PSIG rated cylinder.

Note: *Because a water source heat pump operates under a wide range of water and air temperatures, the values printed below are to be taken as suggested pressure and temperatures.) All Daikin water source heat pumps are designed for commercial use. The units are designed for the cooling mode of operation and fail safe to cooling. The reversing valve is energized for the heating mode of operation.*

Superheat	Head Pressure	Water Delta T
8 to 14 degrees	335-355 PSIG	10° to 14°

All information above is based on ISO standard 13256-1 and tested at these conditions.

General Maintenance

1. Normal maintenance on all units is generally limited to filter changes. Units are provided with permanently lubricated motors and require no oiling even though oil caps may be provided.
2. Filter changes are required at regular intervals. The time period between changes will depend upon the project requirements. Some applications such as motels produce a lot of lint from carpeting and linen changes, and will require more frequent filter changes. Check filters at 60-day intervals for the first year until experience is acquired. If light cannot be seen through the filter when held up to sunlight or a bright light, it should be changed. A more critical standard may be desirable.
3. The condensate drain pan should be checked annually and cleaned and flushed as required.
4. Record performance measurements of volts, amps, and water temperature differences (both heating and cooling). A comparison of logged data with start-up and other annual data is useful as an indicator of general equipment condition.
5. Periodic lockouts almost always are caused by air or water problems. The lockout (shutdown) of the unit is a normal protective result. Check for dirt in the water system, water flow rates, water temperatures, airflow rates (may be a dirty filter), and air temperatures. If the lockout occurs in the morning following a return from night setback, entering air below machine limits may be the cause.

MicroTech III Unit Controller LED Faults

Table 14: Low Voltage Brownout or Emergency Shutdown

Description*	Type	Yellow	Green	Red
Low Voltage Brownout	Fault	OFF	Flash	OFF
Emergency Shutdown	Mode	OFF	Flash	OFF

* Same LED display for both conditions.

- Verify the E terminal is not connected to common. Remove wire, if connected, and LED should change to solid green only.
- Confirm the low voltage supply is between 19-32VAC at the H1 terminal of the main board. If the low voltage supply is out of range, verify the unit supply voltage matches the nameplate voltage and the correct transformer primary wire has been selected.

Table 15: Compressor High Pressure

Description*	Type	Yellow	Green	Red
Compressor High Pressure	Fault	OFF	OFF	Flash

- Verify high pressure switch is connected to terminal H3 on the main board.
- Check for continuity of the high pressure switch.

If the high pressure fault resets when power is cycled:

- Check water flow (cooling operation)
- Check airflow (heating operation)
- Entering water and air temperatures should be within the operating limits.

Table 16: Compressor Low Pressure

Description*	Type	Yellow	Green	Red
Compressor Low Pressure	Fault	OFF	OFF	ON

- Loose wire connection on low pressure circuit
- Failed low pressure switch
- Unit is low on charge

Table 17: Compressor Low Suction Temp

Description*	Type	Yellow	Green	Red
Compressor Low Suction Temp	Fault	Flash	OFF	OFF

- Check water flow (heating operation)
- Check airflow (cooling operation)
- Entering water and air temperatures should be within the operating limits.

Table 18: Condensate Overflow

Description*	Type	Yellow	Green	Red
Condensate Overflow	Fault	ON	OFF	OFF

- Poor condensate drain
- Check the resistance to ground on condensate wire. This should be open if there is no water in the pan.

Table 19: Serial EEPROM Corrupted

Description*	Type	Yellow	Green	Red
Serial EEPROM Corrupted	Fault	ON	ON	ON

- Cycle power to see if problem is corrected.
- Replace main board, only if problem persists after power cycle.

Table 20: Service Test Mode Enabled

Description*	Type	Yellow	Green	Red
Service Test Mode Enabled	Mode	Flash	Flash	Flash

- Jumper JP1 is shorted for service test mode operation. Note: Used only for testing purposes, control timing may damage actual hardware.

Table 21: Unoccupied Mode

Description*	Type	Yellow	Green	Red
Unoccupied Mode	Mode	ON	ON	OFF

- Terminal U on main control board is connected to common from external source, or the network is overriding occupancy mode.

Table 22: Occupied, Bypass Mode, Standby or Tenant Override Modes

Description*	Type	Yellow	Green	Red
Occupied, Bypass Mode, Standby or Tenant Override Modes	Mode	OFF	ON	OFF

• Unit is operating normal. It may currently have a control signal or ready to operate when a control signal is active.

Troubleshooting Refrigeration Circuit

Figure 44: Troubleshooting Refrigeration Circuit

Symptom	Head Pressure	Suction Pressure	Compressor Amp Draw	Super Heat	Subcooling	Air Temp Differential	Water (loops) Temp Differential	Safety Lock Out
Charge Undercharge System (Possible Leak)	Low	Low	Low	High	Low	Low	Low	Low Pressure
Overcharge System	High	High	High	Normal	High	Normal Low	Normal	High Pressure
Low Air Flow Heating	High	High	High	High Normal	Low	High	Low	High Pressure
Low Air Flow Cooling	Low	Low	Low	Low Normal	High	High	Low	Low Temp
Low Water Flow Heating	Low Normal	Low Normal	Low	Low	High	Low	High	Low Temp
Low Water Flow Cooling	High	High	High	High	Low	Low	High	High Pressure
High Air Flow Heating	Low	Low	Low	Low	High	Low	Low	Low Temp
High Air Flow Cooling	Low	High	Normal	High	Low	Low	Normal	High Pressure
High Water Flow Heating	Normal	Low	Normal	High	Normal	Normal	Low	High Pressure
High Water Flow Cooling	Low	Low	Low	Low	High	Normal	Low	Low Temp
TXV Restricted	High	Low	Normal Low	High	High	Low	Low	

Troubleshooting the Water Source Heat Pump Unit

Figure 45: Troubleshooting Guide - Unit Operation

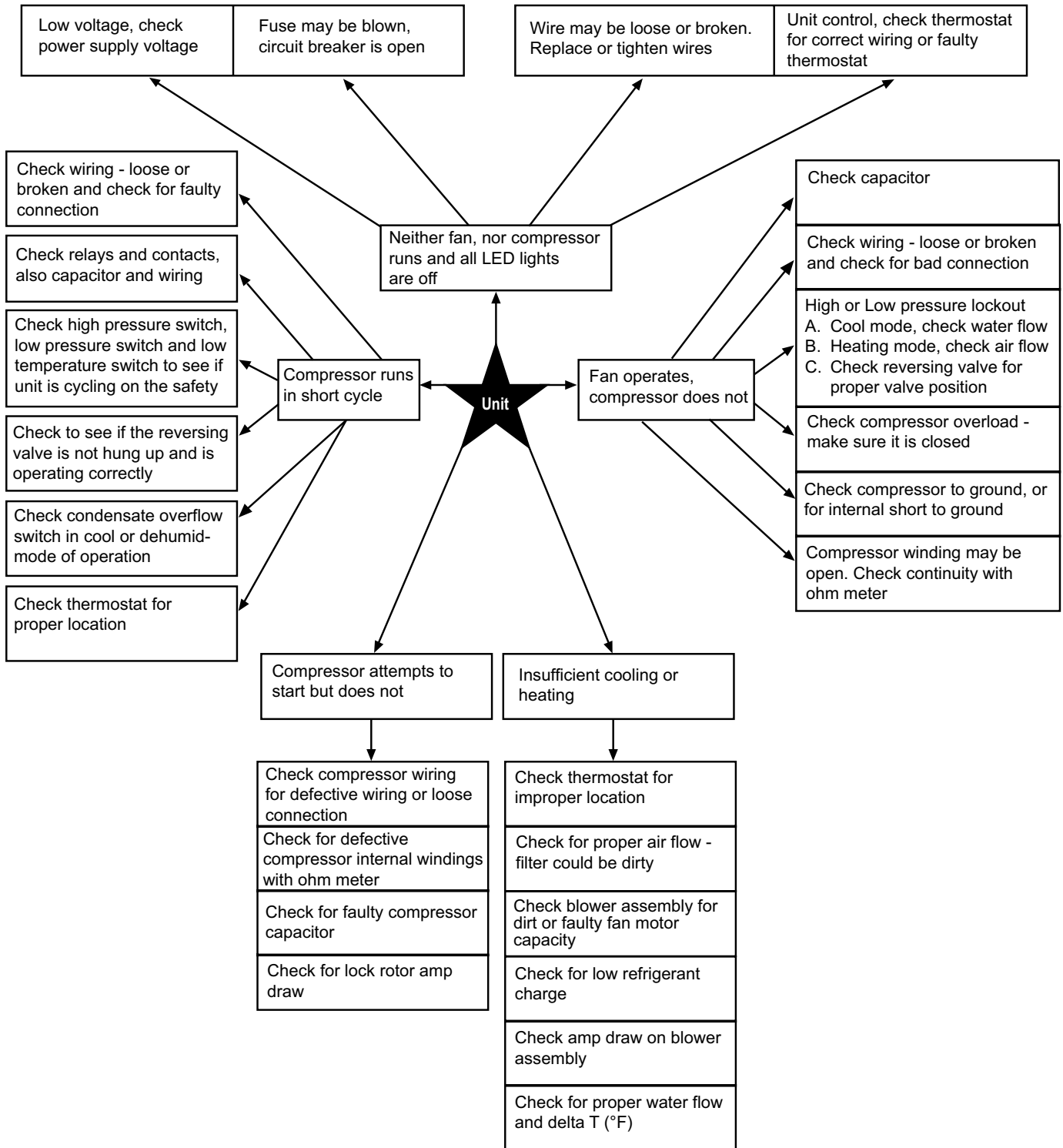
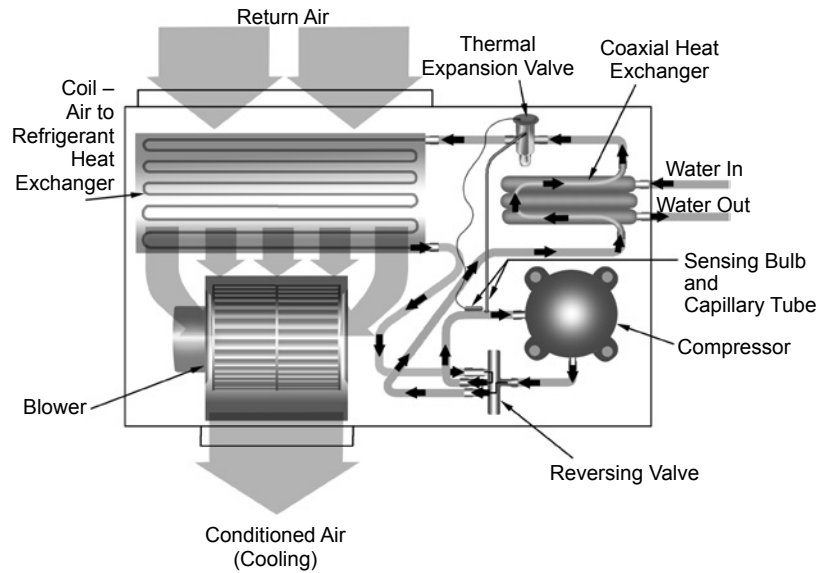

Figure 46: Cooling Mode



Cooling Refrigeration Cycle

When the wall thermostat is calling for COOLING, the reversing valve directs the flow of the refrigerant, a hot gas, leaving the compressor, to the water-to-refrigerant heat exchanger. Here the heat is removed by the water and the hot gas condenses to become a liquid. The liquid then flows through a thermal expansion metering system to the air-to-refrigerant heat exchanger coil. The liquid then evaporates becoming a gas, at the same time absorbing heat and cooling the air passing over the surfaces of the coil. The refrigerant then flows as a low pressure gas through the reversing valve and back to the suction side of the compressor to complete the cycle.

Figure 47: Heating Mode

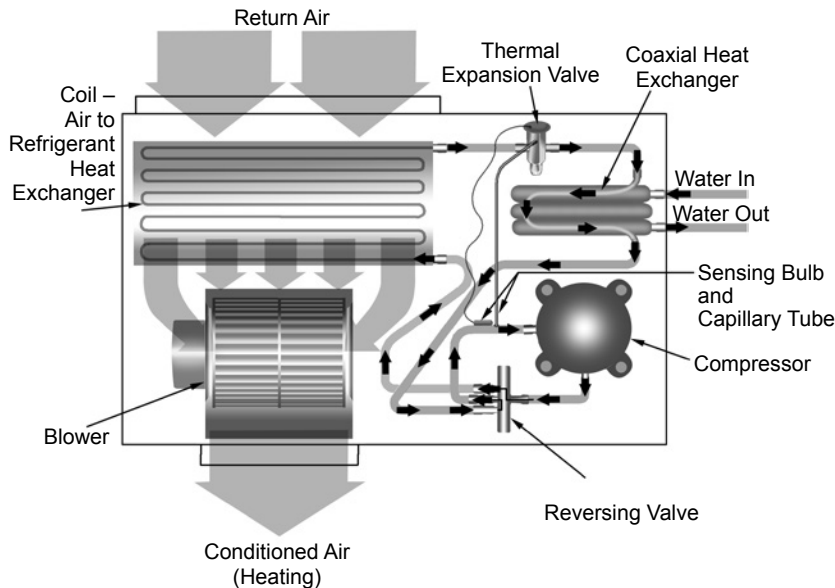

Heating Refrigeration Cycle

When the wall thermostat is calling for HEATING, the reversing valve directs the flow of the refrigerant, a hot gas, leaving the compressor, to the air-to-refrigerant heat exchanger coil. Here the heat is removed by the air passing over the surfaces of the coil and the hot gas condenses to become a liquid. The liquid then flows through a capillary thermal expansion metering system to the water-to-refrigerant heat exchanger. The liquid then evaporates becoming a gas, at the same time absorbing heat and cooling the water. The refrigerant then flows as a low pressure gas through the reversing valve and back to the suction side of the compressor to complete the cycle.

⚠ DANGER

To avoid electrical shock, personal injury or death, be sure that field wiring complies with local and national fire, safety, and electrical codes, and voltage to the system is within the limits shown in the job-specific drawings and unit electrical data plate(s).

Power supply to unit must be disconnected when making field connections. To avoid electrical shock, personal injury or death, be sure to rigorously adhere to field wiring procedures regarding proper lockout and tagout of components.

General Use and Information

The Microtech III unit controller is provided with two drive terminals, R(24VAC) and C(0 VAC) that can be used by the end user to drive the thermostat inputs (G, Y1, Y2, W1, and W2) and control inputs (U, E, and O). Any combination of a single board drive terminal (R or C) may be used to operate the MicroTech III unit controller's control or thermostat inputs. However, only one drive terminal (R or C) can be connected to any individual input terminal or damage may result. Some control inputs are not accessible to the end user (for example, HP, LP, SLTS, and COF).

Typically the Microtech III unit controller's R (24VAC) terminal is used to drive the board's thermostat inputs and control inputs by connecting it to the R terminal of an industry standard thermostat. The control outputs of the standard thermostat are then connected to the Microtech III unit controller thermostat inputs and control inputs as needed. Any remaining board input(s) may be operated by additional thermostat outputs or remote relays (dry contacts only).

All Microtech III unit controller inputs must be operated by dry contacts powered by the control board's power terminals. No solid state devices (Triacs) may be used to operate the Microtech III unit controller inputs. No outside power source may be used to operate the Microtech III unit controller inputs.



Unit Check / Equipment Data

Installation Data

Job Name _____ Check Test Date: _____

City _____ State _____ Zip _____

Daikin Model # _____

Daikin Serial # _____ Job site Unit ID # (HP #) _____

General Contractor: _____ Mechanical Contractor: _____

Technician Performing Start-Up: Name _____ Employer: _____

Complete equipment data from measurements taken at the locatons indicated on the drawing below.

Equipment Data

Flow Rate **EWP - LWP = ΔP**

① EWP - PSI In _____ minus ② LWP - PSI Out _____ equals ΔP _____

The first step in finding GPM is to subtract leaving water pressure from entering water pressure. The difference between the two is referred to as ΔP. ΔP can be converted to GPM by looking in the equipment specifacaton catalog. **Caution ΔP ≠ GPM**

Note: A conversion table must be used to find GPM from (Delta) ΔP measurements.

Loop Fluid Temperature Rise / Drop through Coaxial Heat Exchanger **EWT - LWT = ΔT**

③ EWT - °F Out _____ minus ④ LWT - °F Out _____ equals Fluid ΔT _____

ΔT is the rise or drop in the fluid temperature as it passes through the Coaxial.

Air Temperature Rise / Drop through the air coil **ΔT x CFM x 1.08 = BTUH Sensible**

⑤ EAT - °F In _____ minus ⑥ LAT - °F Out _____ equals Air ΔT _____

Note: Perform Check, Test and Start-Up in the Cooling Mode Only.

- EWT - Entering Water Temperature EWP - Entering Water Pressure EAT - Entering Air Temperature Δ- Delta (Differential)
- LWT - Leaving Water Temperature LWP - Leaving Water Pressure LAT - Leaving Air Temperature CFM - Cubic Feet/Minute
- BTUH - British Thermal Units/Hour

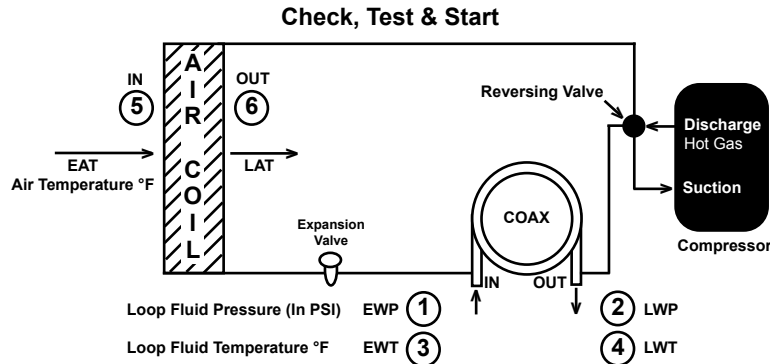

Form No. _____



Commercial Check, Test and Start Worksheet

(Complete all equipment measurements indicated for each unit per installation on previous page)

	Model	Serial #	H.P. #	EWT ③	LWT ④	EWP ①	LWP ②	EAT ⑤	LAT ⑥	Volts	Amps Cool- ing	Check Air Filter and Coil	Comments (more comments on next sheet)
1.													
2.													
3.													
4.													
5.													
6.													
7.													
8.													
9.													
10.													
11.													
12.													
13.													
14.													
15.													
16.													
17.													
18.													
19.													
20.													
21.													
22.													
23.													
24.													
25.													
26.													
27.													
28.													
29.													
30.													
31.													
32.													
33.													
34.													
35.													
36.													
37.													
38.													
39.													
40.													
41.													
42.													

Part No. _____



Daikin Applied Training and Development

Now that you have made an investment in modern, efficient Daikin equipment, its care should be a high priority. For training information on all Daikin HVAC products, please visit us at www.DaikinApplied.com and click on Training, or call 540-248-9646 and ask for the Training Department.

Warranty

All Daikin equipment is sold pursuant to its standard terms and conditions of sale, including Limited Product Warranty. Consult your local Daikin Applied representative for warranty details. Refer to Form 933-430285Y. To find your local Daikin Applied representative, go to www.DaikinApplied.com.

Aftermarket Services

To find your local parts office, visit www.DaikinApplied.com or call 800-37PARTS (800-377-2787).
To find your local service office, visit www.DaikinApplied.com or call 800-432-1342.

This document contains the most current product information as of this printing. For the most up-to-date product information, please go to www.DaikinApplied.com.

Products manufactured in an ISO Certified Facility.