

Mid-Century Collection





2-Drawer Writing Desk

**Assembly Instructions for:
KN005- Walnut/White**

⚠️WARNING:

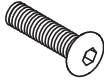
ADULT ASSEMBLY REQUIRED - This product contains hardware that, before being assembled, can pose a choking hazard to children under the age of 3 years. Care should be taken when unpacking and assembling this product.

HARDWARE LIST

 #1 1/4"x32mm	 #2 1/4"x11mm	 #3 1/4"x13mm	 #4 8x30mm	 #5 M4
Bolt 12 PCS (+1 Extra)	Spring Washer 12 PCS (+1 Extra)	Flat Washer 12 PCS (+1 Extra)	Wood Dowel 4 PCS (+1 Extra)	Allen Wrench 1 PC

ADDITIONAL TOOLS (Not Provided)

Note: It is not recommended to use power tools during assembly.

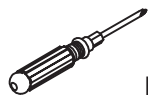

Phillips Head Screwdriver

Note: Wood dowels are intended for alignment. Additional clearance between wood dowel and pre-drilled hole is intentional for ease of assembly.

Step 1.

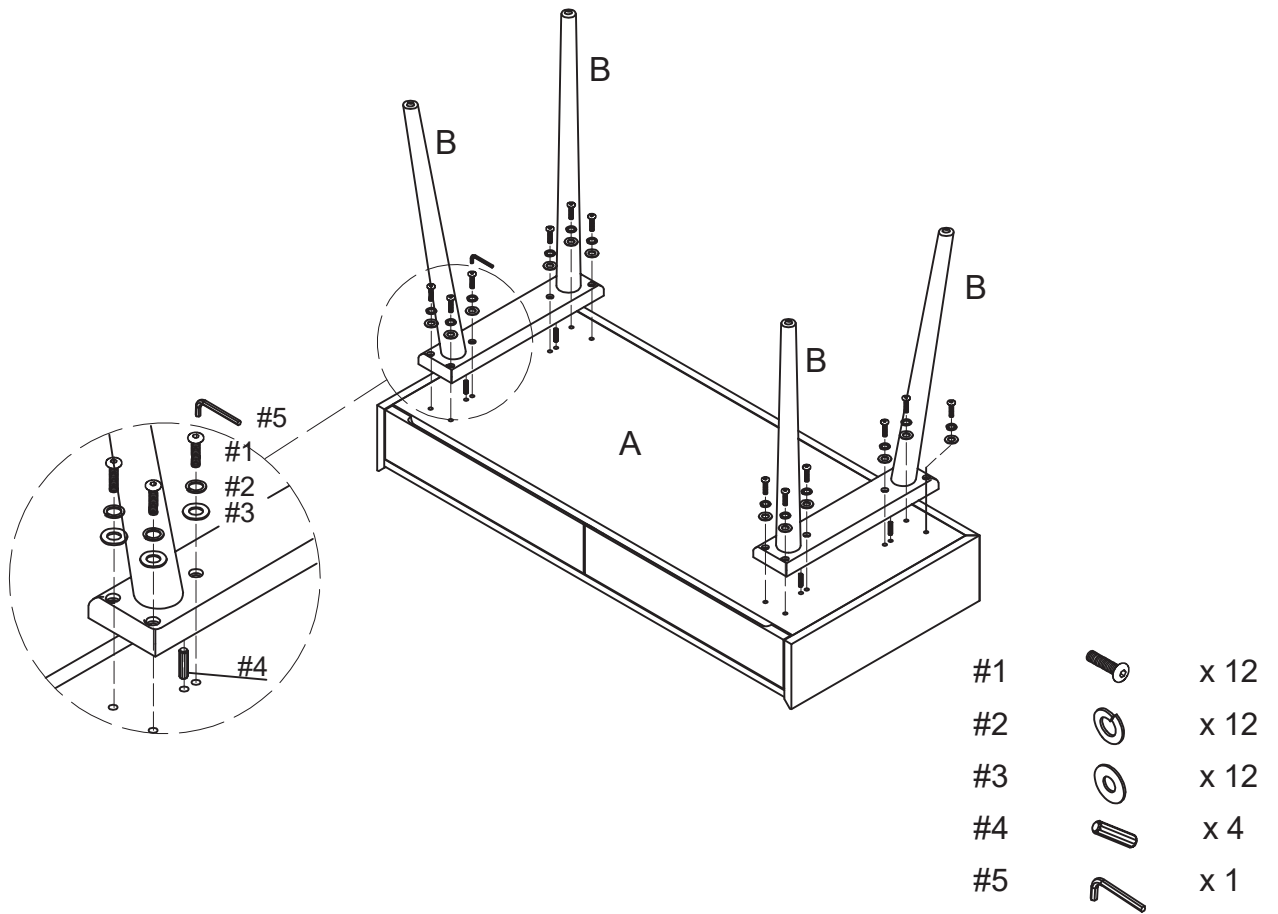

Step 2.

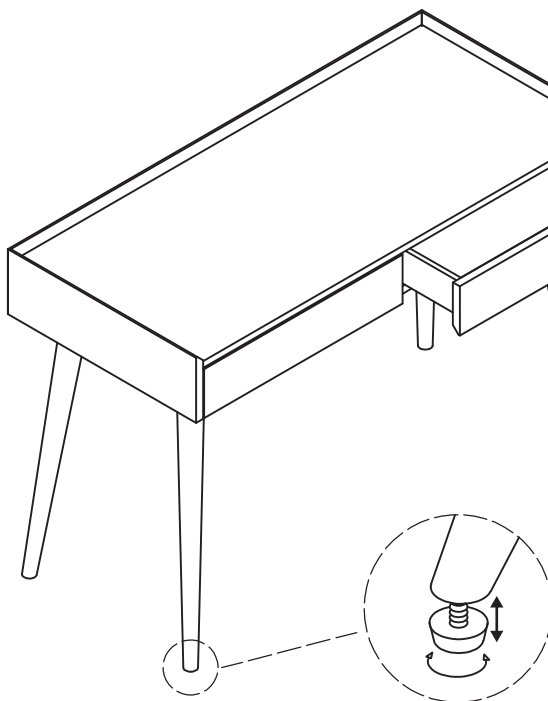

NOTE: It is important to adjust levelers once fully assembled and upright. Extend adjustable levelers until all four levelers are firmly in contact with the floor.

PARTS LIST

A

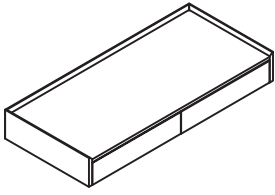

Table Top
1 PC

B

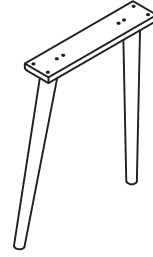
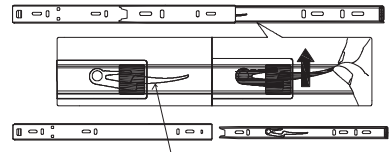
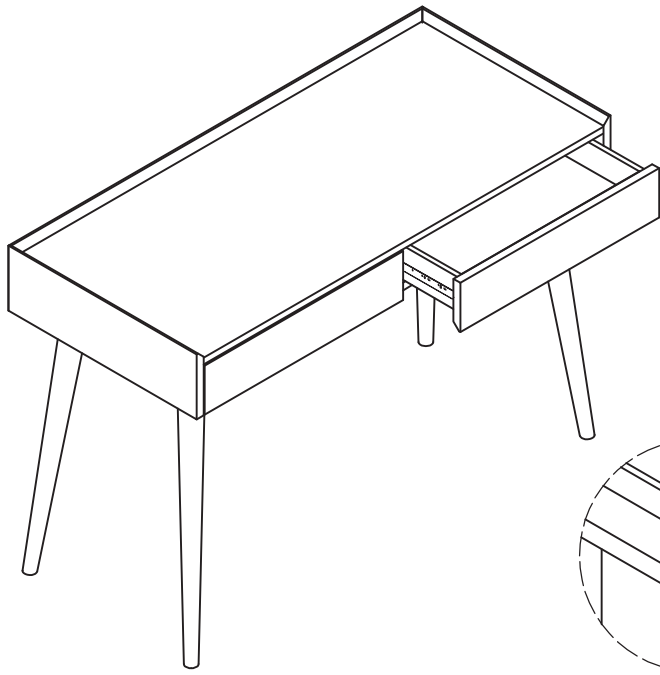
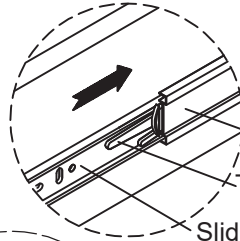

Table Leg
2 PCS

Step 3.



Trigger Disconnect Lever



Slide Track

Trigger Disconnect Lever

Slide Runner

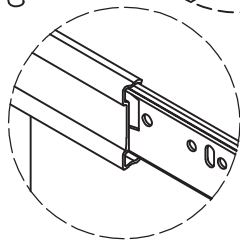

Move the sliders to the front end of rail before sliding the drawer into place.