

# **MAIMIN<sup>®</sup>**

## **Straight Knife Cutting Machine with Flexi-band Sharpener (Model A)**

SABRE 3000

SABRE 2000

# **Instruction and Parts List**

**MACHINE  
SERIAL NO.**

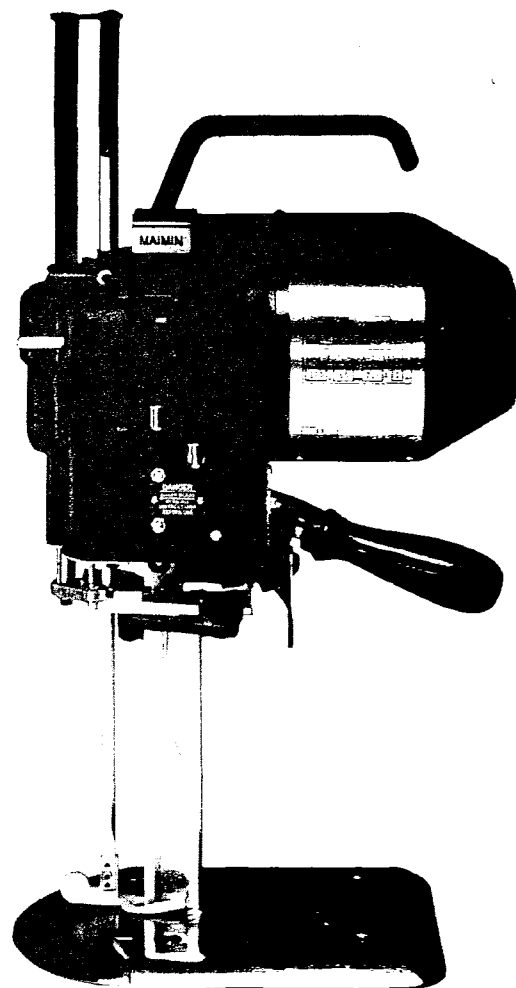

© 2000 H. MAIMIN CO., INC.

**Edition 1.5**

### **IMPORTANT SAFETY INSTRUCTIONS**

When using your cutting machine, basic safety instructions should always be followed including the following:

*This cutting machine is for commercial use only. Read all instructions before using.*

**DANGER**—To reduce the risk of electric shock;

1. Do not install or store this machine in a wet location.

**WARNING**—To reduce the risk of burns, fire, electric shock, or injury to persons:

1. Use machine only for its intended use as a portable cutting machine.
2. Turn machine to "OFF" (O) before connecting or disconnecting power cord.
3. Connect this machine to a properly grounded outlet only. See Grounding Instructions.
4. Always disconnect electrical connector from machine when not using it, before servicing it, or changing blade.
5. Do not leave machine unattended while it is connected to power outlet.
6. Do not operate machine with a damaged cord or if machine has been dropped. Do not disassemble take to a qualified serviceman for repairs. Incorrect assembly can cause electric shock when the machine is used.
7. Keep hands and fingers away from blade and moving parts.
8. Keep guards in place and in working order.
9. The knife key and other wrenches must be removed from machine before starting motor.
10. Keep ventilation openings of machine free from dust and lint.
11. Keep machine clean and blade sharp for best and safest performance.

**Save These Instructions**

Maimin Technology, 2915 Courtyards Dr., Bldg. B, Norcross, GA 30071 USA

Tel: 770.447.1800, Toll Free USA: 800.243.4645, Fax: 770.447.1070, Email: sales@maimin.com

## GROUNDING INSTRUCTIONS

This machine must be grounded. In the event of malfunction or breakdown, grounding provides a path of least resistance for electric current to reduce the risk of electric shock. This machine is equipped with a Ground Shield surrounding the Terminal Pins; this Ground Shield is designed to be used with a Maimin Grounded Connector, part number 458A or 458B. See wiring instructions supplied with the Connector.

**DANGER**—Improper connection of the Maimin Connector can result in a risk of electric shock. Check with a qualified electrician or serviceman if the grounding instructions are not completely understood or if in doubt as to whether the machine is properly grounded.

Do not modify the Ground Shield provided with this machine.

Use correct wire sizes with the Maimin Grounded Connector.

U.S.A. ONLY: 1 phase: Use AWG16/3 SJ, SJT or SJE  
3 phase: Use AWG 16/4 SJ, SJT or SJE

INTERNATIONAL: 1P+N+ : Use 3 x 1, 0 mm CEE (2) 61  
3P+ : Use 4 x 1, 0 mm CEE (2) 61

## I. DESCRIPTION

### 1.1 GENERAL

Your new Maimin Sabre straight knife machine is delivered ready for operation. It is merely necessary to connect it to an electrical outlet of the correct voltage, oil it, and then begin cutting. The straight knife machine can be used for cutting various types of materials from a few ply to the full capacity of the machine. However, for best results, it is recommended that the minimum height of the lay be no lower than the bottom of the cutting blade at its highest position. The Presserfoot Leg (Key No. A403) acts as a protective guard for the operator so that it should be down at all times. The Presserfoot should lie lightly on top of the lay when cutting in order to prevent the material from vibrating.

### 1.2 FLEXIBANDS AVAILABLE

Three different grits of "FlexiBands" are available for sharpening the blade:

Coarse — For hard or coarse materials  
(Part 1450 — Box of 100)  
(Part 1457 — Box of 500)

Medium — For fine woolsens, synthetics and cottons  
(Part 1451 — Box of 100)  
(Part 1458 — Box of 500)

Fine — For sheer fabrics, very soft materials  
(Part 1452 — Box of 100)  
(Part 1459 — Box of 500)

### 1.3 BLADES AVAILABLE

The blades come in three grades and in different shapes for cutting unusual or difficult materials. The three grades available are:

**ZK** — High Speed Steel...Most popular blade as it wears well retaining its cutting edge for a long time.

**BK** — Carbon Alloy Steel... A quality blade less durable than the ZK blade but less costly.

**TK** — Treated High Speed Steel...Retains cutting edge very well. Used only for hard or abrasive materials such as fiberglass or heavy denim as it is very expensive.

See back cover for complete list of part numbers of blades according to size, grade, shape, and quantity.

## II. OPERATION

### 2.1 UNPACKING A NEW MACHINE

During shipment oil may have flowed onto Pulley A303 which can cause sharpener to traverse slowly. Sharpener cycle time is 1.5 seconds. If longer, oil is causing Pulley to slip. To remove oil, disconnect power, remove Brake A342, wipe oil from Pulley and Crank A505. Replace Brake.

### 2.2 TO START

Fill oil cups. Attach Connector A525 to Terminal Pins A523. Move switch A550 from "off" to "on" (USA) or "O" to "I" (International).

**Caution:** 3 phase motor must turn counter-clockwise when viewed from rear. (FlexiBand against Blade must rotate from back to front).

### 2.3 TO SHARPEN BLADE (Figure 1)

Machine should be clear of lay and Presserfoot "A" should be down on Baseplate "B". With motor running, move Tripper Handle "C" to right (facing sharpener) until it latches. Release it. Sharpener will automatically sharpen entire blade. Repeat if necessary.

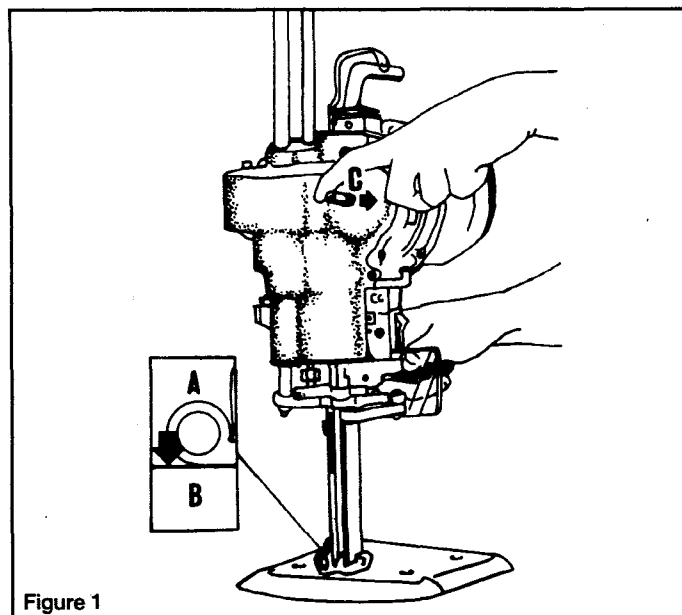

Figure 1

## 2.4 TO CUT

Raise Presserfoot A402 above top of lay by pressing down on Presserfoot Handle A323 and lifting Presserfoot Lift. For Squeeze Trigger, pull Handle 23308 towards machine Handle A549. Enter lay, and lower Presserfoot to top of lay by releasing Presserfoot Trigger. When making turns in lay, it is sometimes advisable to let Presserfoot ride freely on top of lay by pushing down on Presserfoot Handle. When machine is not in use, always lower Presserfoot to Baseplate. The Presserfoot Leg acts as a safety guard for the blade.

## 2.5 TO CHANGE FLEXIBANDS (Figures 2 and 3)

- Disconnect power.
- Figure 2: Push Block "A" to release right (upper) FlexiBand "B". Remove FlexiBand from Block and then from Drive Pulley "C".
- Figure 3: Slip new FlexiBand "B" over Drive Pulley "C" and between Band Plate "D" and Blade "E." Push Block "A" forward and slide FlexiBand over it. Release Block "A."
- Remove left (lower) FlexiBand, and install new one in same manner.

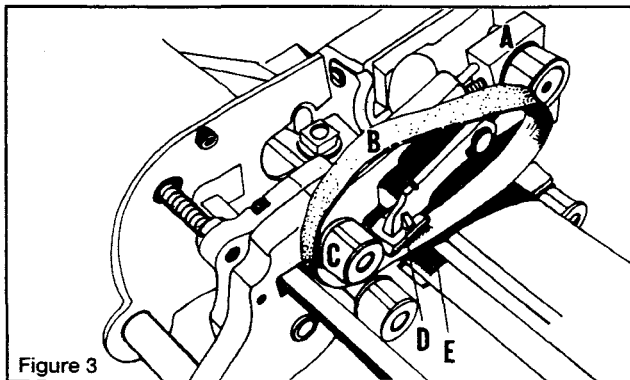
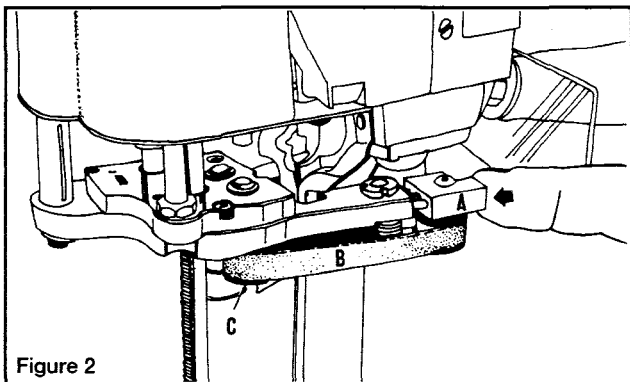

## 2.6 TO CHANGE BLADE (Figure 4)

- Disconnect power and lower Presserfoot Leg.
- Lay machine on left side.
- Press and turn Thumbwheel "A" to move Blade to its lowest position.
- With Knife Key "B" turn Nut "C" counter clockwise to unlock blade.
- Raise Presserfoot Leg and slide Blade "D" downwards and out.
- Clean Inserts "E" with slot cleaning tool or bottom corner of blade.
- Slide new Blade up against Knife Locking Bolt.
- Holding lower part of Blade behind edge, push it firmly **up** against Bolt and **back** against Inserts.
- Tighten Nut "C."

**Note:** Use only genuine Maimin Blades with "Cut-Out" and T-shaped slot in shank for optimum performance and safe operation.

**Always tighten Knife Locking Bolt and Nut before running machine to prevent damage to Crosshead A510 and Gibbs A513. Do not run sharpener without blade in machine or sharpener will jam.**

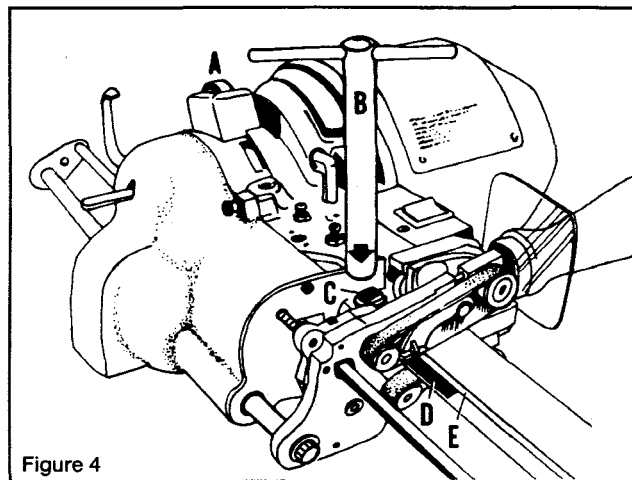

## 2.7 TO CHANGE BEVEL WIDTH ON BLADE (Figure 5)

- Run sharpener to lowest position, turn off motor, disconnect power.
- Loosen Screw "A."
- Insert Bevel Adjusting Tool "B" into Washer "C" and rotate Washer to increase or decrease blade bevel width. Note arrow on washer and edge width indicator on Band Plate Carrier (A374).
- Tighten Screw "A."
- Bevel on opposite side is adjusted in same manner.

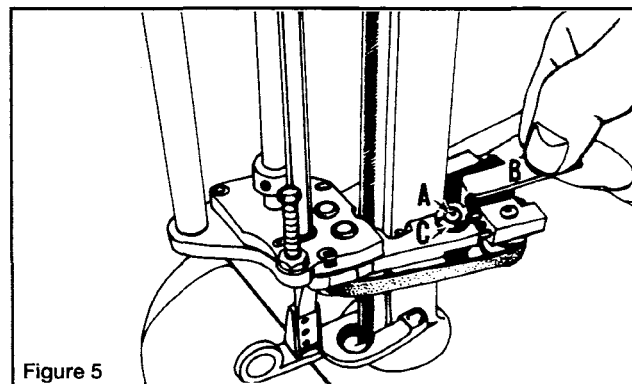

## 2.8 MAINTENANCE SCHEDULE

- Daily: Fill oil cups (A547). Use either Maimin Oil 22109 or quality "30 weight" oil (I.S.O. viscosity grade 220).
- Weekly:
  - Sharpener — run to lowest position, turn off motor, and blow out lint and dust with compressed air.
  - Motor — run motor, and point stream of compressed air into back of motor and side of front housing by fan to eject lint and dust.
- Every 500 hours of operation:
  - Sharpener — Remove Cap Screw (A367A) from top of Gear Case (A367) and squeeze in a small amount of Grease 22174 to coat gears.
  - Motor — Remove motor cover and, with compressed air, blow lint and dust from motor coils and armature.

## 2.9 TO REMOVE SHARPENER FROM MACHINE (Figure 6)

- Run sharpener to lowest position, turn off motor and disconnect power.
- Figure 6: Disengage Tripper Handle "A" by inserting handle of Knife Key "B" through hole in lower cover and pressing upwards until Tripper Handle snaps back to its "off" position.
- Remove Screw A390 holding Clamp Plate A394 against Band Plate Guide A393 and remove Guide and Plate.
- With 3/8" wrench remove 2 Nuts A344 and 2 Washers A343 holding Brake A342, and remove Brake.
- Remove Screw A316 holding Shafts Cover A315, and lift off Cover.
- Remove 3 Nuts A328 and 1 Nut 510B (at lower left rear corner of sharpener) which hold Drive Housing A327.
- Pull sharpener forward gently to remove.

## 2.10 TO ATTACH SHARPENER TO MACHINE

- Disconnect power.
- Wipe oil from outer diameter of Crank A505 and Pulley A303.
- Place sharpener onto 3 mounting Screws A521 on Front Housing.
- Add and tighten 3 Nuts A328 and Nut 510B on back of sharpener.

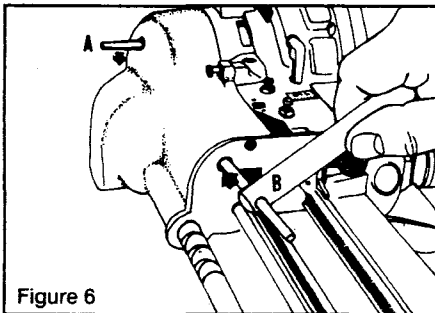

Figure 6

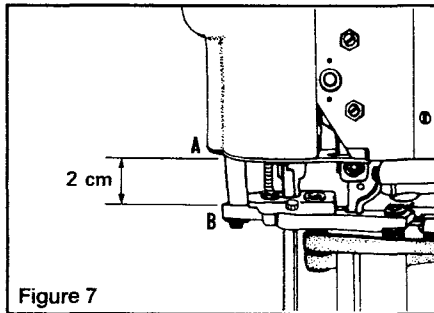

Figure 7

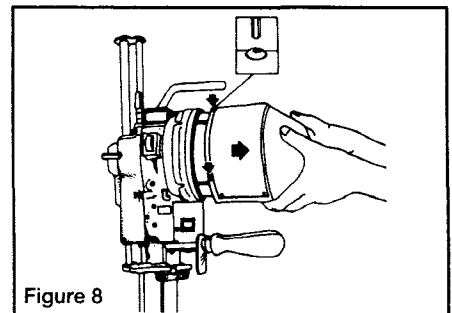

Figure 8

- Add Band Plate Guide A393 and Clamp Plate A394.
- Hold Guide against Standard A564 and tighten Screw A390.
- Lower Presserfoot Leg to Baseplate, connect power, and run sharpener to its top position. Disconnect power.
- Add Shafts Cover A315.
- Add Brake A342.

## 2.11 TO SET POSITION OF BAND PLATE CARRIER A374 (Figure 7)

- Run sharpener to highest position, turn off motor, and disconnect power.
- Figure 7: Measure distance between Cover "A" (A361) and top of Gear Case "B" (A367). Maximum distance is 25/32" (2 cm) when Screw A363 is adjusted properly.
- If distance is greater, loosen Nut A366 and lower Screw A363 a few turns. Tighten Nut, run sharpener, and measure again.
- FlexiBands A386 must not touch blade A574 when sharpener is at top position.

## 2.12 TO REMOVE MOTOR COVER A579 (Figure 8)

Disconnect Power. Loosen the 3 Screws A580, and slide Motor Cover off.

## III. TROUBLE SHOOTING GUIDE

### 3.1 MACHINE TROUBLE SHOOTING

Symptom	Possible Cause
1. Bottom corner of blade breaks.	a) Inserts (A558) badly worn.
2. Motor slow in reaching full speed.	b) Knife strikes throat plate. If cutting hard materials, use wide slot throat plate.
3. Motor binds at one spot.	a) Low voltage or wrong voltage.
4. Motor becomes hot.	b) Three phase:
5. Motor rotates wrong way.	(1) Fuse out on one phase.
6. Motor does not start.	(2) Ground wire incorrectly connected to machine.
7. Terminal Block and/or Connector becomes very hot.	a) Crosshead (A510) and Gibbs (A513) tight.
8. Machine does not roll freely on table.	b) Standard (A564) not in alignment with Crosshead (A510).
	c) Standard (A564) bent.
	a) Lint and dust inside Motor Cover (A579).
	b) Three phase: one phase not working.
	a) Three phase: Wiring incorrect. Change any two wires in Terminal Block (A522) or Connector (A525).
	a) Connector (A525) not firmly attached to Terminal Pins (A523).
	b) Switch (A550) defective.
	c) Starting Switch or Relay (A540) and/or Capacitor (A543) defective.
	d) Broken Jumper Wire. (Capacitor to Starting Switch or Relay)
	a) Inserts in Connector (A525) worn. Change Connector.
	b) Terminal Pins (A523) worn.
	a) Surface of cutting table not smooth.
	b) Cushions (A561) in Roller Carriers compressed causing Baseplate (A560) to drag on table.

### 3.2 SHARPENER TROUBLE SHOOTING

#### Symptom

#### Possible Cause

- |  |  |
|--|--|
| 1. No bevel on one side of blade.                    | a) Broken Torsion Spring (A382, A388).<br>b) Band Plates (A381, A387) do not pivot freely.<br>c) Bands do not cross due to interference of Band Plates (A381, A387).   |
| 2. Sharpener runs but bands do not rotate.           | a) Square Shaft Gear (A336) broken.<br>b) Retaining Ring (A338) missing.<br>c) Clamp (A364) out of position.   |
| 3. Sharpener does not run but bands rotate.          | a) Keeper Plate (A334) loose.<br>b) Boat (A333) worn.<br>c) Diamond Shaft (A356) worn.   |
| 4. Sharpener does not run, bands do not rotate.      | a) Presserfoot Leg (A403) not down completely.<br>b) Oil on Crank (A505) and/or Pulley (A303).<br>c) Retaining Ring (A320) missing.<br>d) Cluster Gear (A332) broken.  |
| 5. Band cut off by blade.                            | a) Band Plate (A387) defective.  |
| 6. Block (A397) falls off during band changing.      | a) Retaining Ring (A398) missing.  |
| 7. Block (A397) pivots, twisting band.               | a) Stud (A383) broken.   |
| 8. Sharpener runs slowly.                            | a) Oil on Crank (A505) and/or Pulley (A303).<br>b) Band Plate Guide (A393) too tight against Standard (A564).<br>c) Worn Pulley (A303).<br>d) Dirt in Cartridge (A318).<br>e) Bent Link (A346).<br>f) Worn Push Rod Cam (A314) and/or Tripper (A350).<br>g) Add Grease 22174 to Band Plate Carrier Gears (A374). |
| 9. Sharpener overruns top position.                  | a) Screw (A363) too low.   |
| 10. Sharpener runs continuously.                     | a) Screw (A363) too low—less than 1" above Gear Case (A367).   |
| 11. Sharpener runs only when Tripper Handle is held. | a) Pin (A348) broken.<br>b) Worn Push Rod Cam (A314) and/or Tripper (A350).  |
| 12. Sharpener jams.                                  | a) Sharpener run without knife in machine.<br>b) Boat (A333) broken.<br>c) Diamond Shaft (A356) bent.<br>d) Standard (A564) bent.<br>e) Nylon Washer (A360A) broken.   |
| 13. Presserfoot Leg (A403) does not move freely.     | a) Sharpener not at top position.<br>b) Dirt in Leg Guide (A354).<br>c) Brake (A342) too close to Pulley.<br>d) Presserfoot Leg (A403) bent.   |
| 14. Presserfoot Leg does not hold.                   | a) Lock (A330) loose on Shaft (A325).<br>b) Presserfoot Handle Spring (A322) broken.<br>c) Teeth worn on Lock (A330).<br>d) Screw (A324) loose.  |
| 15. Safety not working.                              | a) Leg Guide (A354) broken.<br>b) Link (A346) bent.  |
| 16. Bands touch blade in top position.               | a) Screw (A363) too high.<br>b) Cams (A515, A516) too high, broken or bent.  |
| 17. Bevel very wide on both sides of blade.          | a) Worn Band Plates (A387, A381).<br>b) Band Plate Guide (A393) too tight.   |

# MODEL A SHARPENER

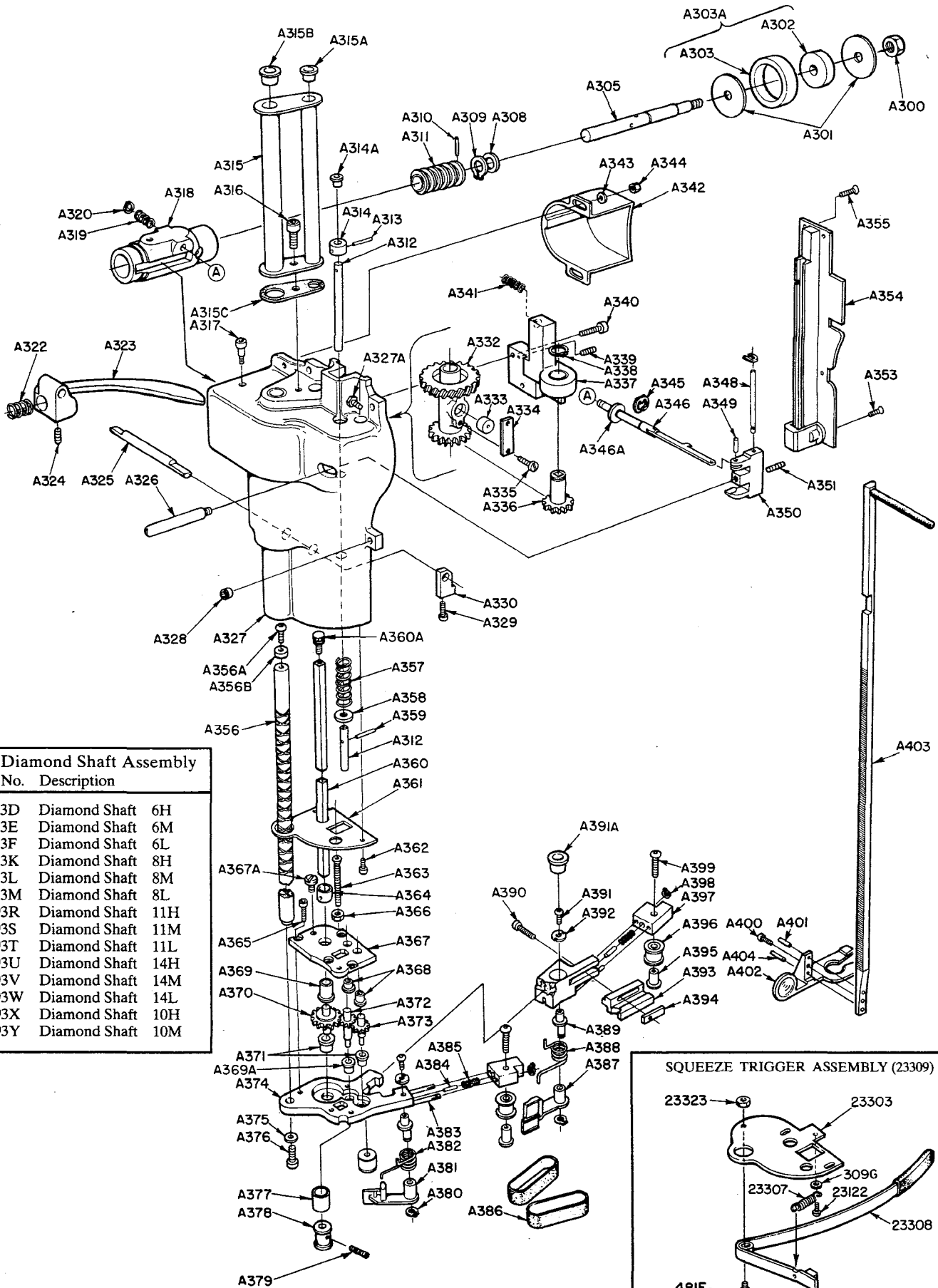

**A356 Diamond Shaft Assembly**

Part No.	Description
23093D	Diamond Shaft 6H
23093E	Diamond Shaft 6M
23093F	Diamond Shaft 6L
23093K	Diamond Shaft 8H
23093L	Diamond Shaft 8M
23093M	Diamond Shaft 8L
23093R	Diamond Shaft 11H
23093S	Diamond Shaft 11M
23093T	Diamond Shaft 11L
23093U	Diamond Shaft 14H
23093V	Diamond Shaft 14M
23093W	Diamond Shaft 14L
23093X	Diamond Shaft 10H
23093Y	Diamond Shaft 10M

# PARTS LIST

KEY NO.	PART NO.	DESCRIPTION	KEY NO.	PART NO.	DESCRIPTION
A300	838N	Nut, 1/4-20 Hex	A361	23244	Cover
A301	1499D	Washer		23303	Cover, Squeeze Trigger Only
A303	23340	Pulley Wheel Assembly	A362	23226	Screw, 6 x 1/4 Socket Hd. Cap (2)
A303A	23341	Pulley Wheel Assembly w/1499D Washers	A363	23290	Screw, 10 x 1-1/2 Filister Hd.
A305A	23196	Worm Shaft	A364	23212	Clamp w/23263
A308	839W	Washer 32 x 1/2 x 1/32		23263	Screw, 10 x 1/2 Slot Set Flat Pt.
A309	23234	Retaining Ring 5100-31	A365	824T	Screw, 6 x 3/8 Socket Cap (4)
A310	23066	Spring Pin, 7/64 x 1/2	A366	836N	Keypnut, 10-32 Hex
A311	23067	Worm	A367	23275	Gear Case with Bushings
A312	23036	Push Rod	A367A	436S	Gear Case Grease Screw
A313	23267	Spring Pin, 1/16 x 3/8	A368	23086	Bearing, flanged .252 x .377 x 1/4
A314	23005	Cam	A369	23091	Bearing, flanged .252 x .377 x 1/2
A314A	402BL	Tapered Plug #181	A369A	23091A	Bearing, Left Driven Gear
A315	23229E	Shafts Cover, 6" & 8"	A370	23210	Drive Gear
	23229C	Shafts Cover, 10" & 11"	A371	23086	Bearing, flanged .252 x .377 x 1/4
	23229D	Shafts Cover, 14"	A372	23208	Driven Gear, left
A315A	402BL	Tapered Plug #181	A373	23209	Driven Gear, right
A315B	402BJ	Tapered Plug #241	A374	23276	Band Plate Carrier w/Bushings & Studs
A316	23261	Washer .203 x .500 x .047	A375	23261	Washer, 3/16 x 1/2 x 3/64
	446S	Screw 10-32 x 3/4 Socket Cap	A376	23084	Screw, 10 x 1/2 Socket Hd. Cap
A317	481FA	Screw 1/4 x 3/8 x 11/16 Lg Shoulder (2)	A377	23098	Rubber Tire (2)
A318	23192	Cartridge w/Worm & Pulley	A378	23099	Drive Pulley (2)
A319	23017	Spring	A379	23097	Screw, 4 x 1/8 Soc. Set Flat Pt. (2)
A320	23219	Retaining Ring 5555-23	A380	23227	Retaining Ring 5100-25 (2)
A322	492	Trigger Spring	A381	23165	Band Plate, right
A323	23047	Presserfoot Handle	A382	23110	Spring, Torsion, right
A324	490	Screw, 5/16 x 3/8 Set	A383	23115	Stud, 1/8 x 1-1/8 (4)
A325	23049	Shaft	A384	23116	Spring Pin, 3/32 x 1/4 (2)
A326	23053	Tripper Handle	A385	23117	Spring (2)
A327	232740	Drive Housing with Bushing	A386	1450	Flexiband, Coarse- 100/box
A327A	510A	Screw, 10 x 1/2 Socket Set Cap		1451	Flexiband, Medium- 100/box
	510B	Nut, 10-32 Hex		1452	Flexiband, Fine- 100/box
A328	23252	Nut, 10-32 Socket (3)	A387	23164	Band Plate, left
A329	23271	Screw, 8 x 5/8 Socket Hd. Cap	A388	23109	Spring, Torsion, left
A330	23050	Lock	A389	23223	Eccentric Stud (2)
A332	23189	Cluster Gear	A390	23019	Screw, 6 x 5/8 Socket Cap
	23243	Cup (2)	A391	802S	Screw, 6 x 3/16 Pan Hd. (2)
A333	23119A	Boat w/Keeper Plate 23120	A391A	402BJ	Tapered Plug #241
A334	23120	Keeper Plate	A392	23225	Washer (2)
A335	23259	Screw, 6 x 1/4 (2)	A393	23250	Band Plate Guide, 6"
A336	23203	Square Shaft Gear		23250A	Band Plate Guide, 8" & 10"
A337	23273	Gear Block with Bushings		23282	Band Plate Guide, 11" & 14"
A338	1277	Retaining Ring 5108-50	A394	23249	Clamp Plate
A339	23251	Screw, 10 x 3/4 Soc. Set Flat Pt.	A395	23114	Stud, Idler Pulley (2)
A340	23019	Screw 6 x 5/8 Socket Cap (2)	A396	23293	Pulley, Idler, w/Bushing (2)
A341	23091	Spring	A397	23111	Block (2)
A342	23200	Brake		23280	Block w/Idler Pulley, left
A343	23007	Washer, 13/64 x 7/16 x 1/32 (2)		23281	Block w/Idler Pulley, right
A344	510B	Nut, 10-32 Hex (2)	A398	23288	Retaining Ring, 5144-12 (2)
A345	23016	Retaining Ring 5144-25	A399	23112	Screw, 8 x 1/2 Button Hd. (2)
A346	23284	Link Assembly	A400	23316	Lockwasher, #4 Split
A346A	23344	Washer, .255 x .468 x 1/32		23318	Screw, # 4 x 3/8 Socket Head Cap
A348	23328	Tripper Pin w/840D		23319	Lock Nut, #4-40 Hex
	23011A	Tripper Pin Only	A401	23013	Spring Pin, 3/32 x 5/16
	840D	Retaining Ring	A402	23040	Presserfoot, 6", 8", 10", 11", 14"
A349	23013	Spring Pin, 3/32 x 5/16	A403	23042B	Presserfoot Leg w/Lift 824A- 6"
A350	23190	Tripper		23042D	Presserfoot Leg w/Lift 824A- 8"
A351	23054	Screw, 6 x 1/8 Socket Set Cap		23042H	Presserfoot Leg w/Lift 824A- 10"
A353	23258	Screw 4 x 3/8		23042F	Presserfoot Leg w/Lift 824A- 11"
A354	23217	Leg Guide w/Leg Keeper		23042G	Presserfoot Leg w/Lift 824A- 14"
	23325	Leg Guide Assy, Squeeze Trigger Only	A404	23013	Spring Pin, 3/32 x 5/16
A355	23122	Screw, 6 x 1/4 Button Hd. Socket Cap (4)		SQUEEZE TRIGGER ASSEMBLY (23309C)	
A356	23093D-Y	Diamond Shaft Assy. (see Chart Pg. 6)		23122	Screw, 6 x 1/4 Button Hd.
A356A	23286	Screw, 10 X 1/2 Button Hd. Soc. Cap 14" Machines Only		23303	Cover, Squeeze Trigger Only
				23307	Spring
A356B	23287	Washer, Nylon, 14" Machines Only		23309	Squeeze Trigger Handle Assembly
A357	23008	Spring		23323	Locknut 10-24
A358	23007	Washer, 13/64 x 7/16 x 1/32		309G	Brass Washer
A359	23267	Spring Pin, 1/16 x 3/8		481F	Screw, 1/4 x 3/8 Shoulder
A360	23211A	Square Shaft, 6" & 8"			
	232211C	Square Shaft, 10" & 11"			
	23211D	Square Shaft, 14"			
A360A	23320	Washer, Nylon, Square Shaft			
	23321	Screw, 6 x 3/8 Button Hd. Socket Cap			

Always Give Machine SERIAL NUMBER When Ordering Parts.  
Order By PART NUMBER — Not Key Number



## SABRE 2000 AND 3000 MOTORS WITH STANDARD ASSEMBLIES

FOR MOTOR CODES AP1, AP2, AP3, AP4, AP8, AR1, AR2, AR3, AR4, AR8, ONLY

MOTOR CODES REFER TO FIRST 3 OR 4 DIGITS  
 IN SERIAL NO. BOX ON NAMEBAND AS SHOWN

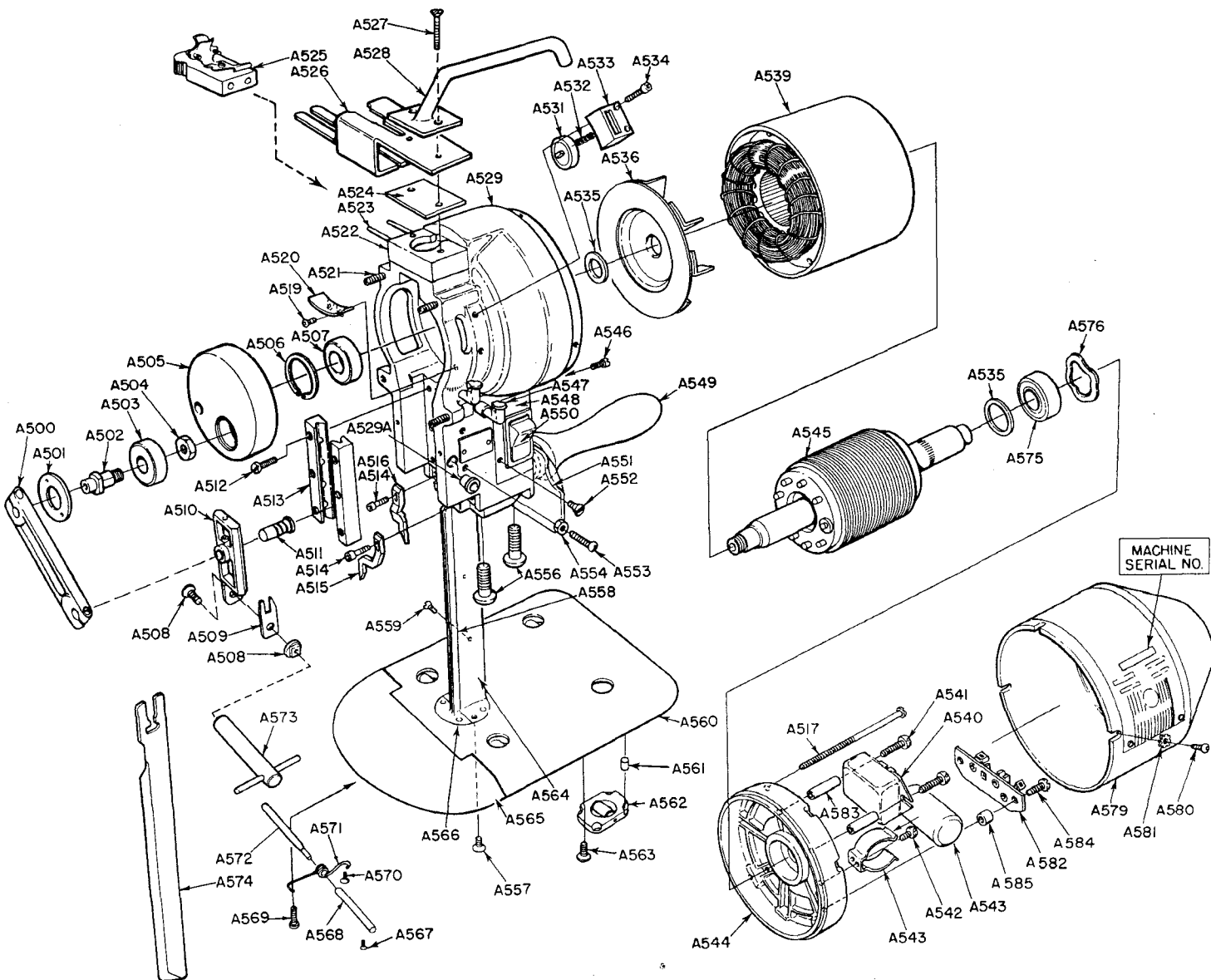
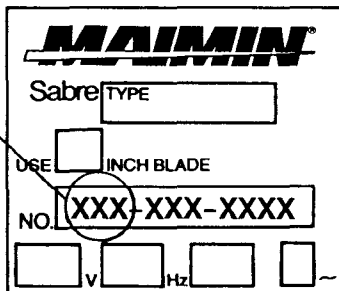



# PARTS LIST

KEY NO.	PART NO.		DESCRIPTION	KEY NO.	PART NO.		DESCRIPTION
	SABRE 2000	SABRE 3000			SABRE 2000	SABRE 3000	
A500	412A	412A	Connecting Rod — H			15282	Armature Assembly, Sabre 3000
	412B	412B	Connecting Rod — M	A546	441S	441S	Screw, 6 x 3/16 Fillister Hd. (2)
	412C	412C	Connecting Rod — L	A547	402BD	402BD	Oil Cup
A501	413W	413W	Bearing Lock		402B	402B	Oil Cup Assembly with Tube
A502	415	415	Crank Pin	A548	466G	466G	Cover, Switch Box
A503	414	414	Crank Bearing	A549	464P	464P	Contoured Handle w/Bushing
A504	415N	415N	Crank Nut	A550	443	443	Switch
A505	413BX	413BX	Crank w/413W, 414, 415-H	A551	464R	464R	Shield
	413CX	413CX	Crank w/413W, 414, 415-M	A552	818S	818S	Screw, 6 x 1/4 Flat Hd.
	413DX	413DX	Crank w/413W, 414, 415-L	A553	410	410	Screw, 8 x 1/2 Fillister Hd. (2)
A506	404E	404E	Retaining Ring	A554	410N	410N	Nut (2)
A507	403	403	Bearing #203	A556	425A	425A	Bolt, 3/8 x 3/4 Button Hd. (3)
A508	416	416	Knife Bolt & Nut	A557	427S	427S	Screw, 10 x 3/8 Flat Hd. Soc. (6)
A509	411A	411A	T-Slot Lock	A558	428B	428B	Insert for Standard — 8"
A510	411	411	Crosshead w/411P		428D	428D	Insert for Standard — 6"
A511	411P	411P	Wrist Pin		428G	428G	Insert for Standard — 10"
A512	409A	409A	Screw, 8 x 3/4 Fillister Hd. (6)		428H	428H	Insert for Standard — 11"
A513	409C	409C	Gibbs, pair		428M	428M	Insert for Standard — 14"
A514	23226	23226	Screw, 6 x 1/4 Socket Hd. (2)	A559	428T	428T	Insert Screw
A515	23151	23151	Cam, Right	A560	429C	429C	Baseplate with Rollers & Lip
A516	23152	23152	Cam, Left		440L	440L	Swivel Baseplate with Rollers & Lip
A517	419U	—	Motor Bolt, 8-32 x 4 1/2 Hex Washer Hd. (4)	A561	436K	436K	Rubber Cushion
	—	419F	Motor Bolt, 8-32 x 4 3/4 Hex Washer Hd. (4)	A562	436	436	Roller Carrier Assembly
					440M	440M	Swivel Roller Assembly (Rear)
A519	802S	802S	Screw, 6 x 3/16 Binding Hd. (2)		440J	440J	Swivel Adaptor Ring
A520	402L	402L	Oil Guard	A563	436S	436S	Screw, 10 x 5/32 M Hd.
A521	23230	23230	Screw, 10 x 7/8 Flat Pt. Soc. Set (3)	A564	424BS	424BS	Standard — 8"
A522	405	405	Terminal Block with Pins		424DS	424DS	Standard — 6"
A523	406	406	Terminal Pin (2)		424GS	424GS	Standard — 10"
A524	405PE	405PE	Fibre Cover		424HS	424HS	Standard — 11"
A525	458B	458B	Current Connector		424MS	424MS	Standard — 14"
A526	458K	458K	Ground Shield	A565	430	430	Lip
A527	408	408	Screw, 8 x 1 1/8 Flat Hd.	A566	426A	426A	Throat Plate — 6", 8"
A528	407D	407D	Top Handle		426B	426B	Throat Plate — 10", 11", 14"
A529	402AB	402AB	Front Housing w/23230 (3)		426C	426C	Throat Plate, Wide Slot — 6", 8", 10"
A529A	402BG	402BG	Tapered Plug #7-S		426E	426E	V Throat Plate — 6", 8"
A531	468J	468J	Thumbwheel w/Shaft		426F	426F	V Throat Plate — 10", 11", 14"
A532	468C	468C	Spring	A567	436S	436S	Screw, 10 x 5/32 M Hd.
A533	468D	468D	Thumbwheel Support	A568	431B	431B	Shaft, Short
	468A	468A	Thumbwheel Assembly	A569	802S	802S	Screw, 6 x 3/16 Binding Hd.
A534	468S	468S	Screw, 6 x 7/8 Socket Hd. (2)	A570	802S	802S	Screw, 6 x 3/16 Binding Hd.
A535	497P	497P	Support Washer	A571	433A	433A	Spring, Lip
A536	400K	400K	Fan	A572	431A	431A	Shaft, Long
A539	15260	—	Shell & Field Assembly, SABRE 2000	A573	457	457	Knife Key
	—	15283	Shell & Field Assembly, SABRE 3000	A574	—	—	Blade (see back cover)
A540	365A	—	Starting Switch, SABRE 2000	A575	403	403	Bearing #203
	—	365J	Starting Switch, SABRE 3000	A576	15195	15195	Loading Spring
A541	15264	15264	Screw, 8-32 x 1 1/4 Phillips Pan Hd. (2)	A579	302QB	—	Motor Cover, SABRE 2000
	15288	15288	Washer 3/8 x .175 x .035 (2)		—	302QM	Motor Cover, SABRE 3000
A542	15266	15266	Screw, 8-32 x 3/8 Phillips Pan Hd.	A580	23122	23122	Screw, 6 x 1/4 Button Hd. (3)
A543	15262	15262	Capacitor Clamp	A581	309F	309F	Lockwasher, #6 (3)
	15079	—	Capacitor 161 mfd — Sabre 2000	A582	483G	483G	Terminal Strip
	—	15076	Capacitor 270 mfd — Sabre 3000	A583	15265	15265	Spacer, Starting Switch (2)
A544	15261	15261	Back Housing	A584	15267	15267	Screw, 8-32 x 3/8 Phillips Pan Hd. (2)
A545	15277	—	Armature Assembly, Sabre 2000	A585	15268	15268	Spacer, Terminal Strip (2)

Always Give Machine SERIAL NUMBER When Ordering Parts.  
Order By PART NUMBER — Not Key Number

## H. MAIMIN CO., INC.

P.O. BOX 549 — ROUTE 341, KENT, CONNECTICUT 06757, U.S.A.  
PHONE: (203) 927-4601 FAX: (203) 927-4703

**SUPPLEMENT PARTS SHEET FOR MAIMIN  
SABRE 2000 STRAIGHT KNIFE MACHINE  
ONLY FOR SERIAL NUMBERS BEGINNING WITH AP51, AP 61, OR AP71  
AND ENDING WITH -30123 OR HIGHER**

Key No.	Part Number		Description
	1-Phase	3-Phase	
A505	-	413LX	Crank w/413W, 414, 415-H
	-	413MX	Crank w/413W, 414, 415-M
	-	413NX	Crank w/413W, 414, 415-L
	-	413VA	Screw, 1/4 x 1/4 Flat Pt. Soc. Set
	-	413VB	Screw, 10 x 3/16 Flat Pt. Soc. Set
A517	-	419U	Motor Bolt, 8 x 4 1/2 (4)
A522	-	405AA	Terminal Block
A523	-	406A	Terminal Pin (3)
A524	-	405B	Cover
A525	-	458A	Connector, 3 Phase
A526	-	458MA	Ground Shield
A527	-	408B	Screw, 8-32 x 2 Flat Hd.
A529	-	402AF	Front Housing w/ 23230 (3)
A539	-	15348	Shell & Field Assembly
A544	-	15349	Back Housing
A545	-	15227	Armature Assembly, Sabre 2000
A549	-	464S	Soft Grip Handle Assembly
A559	-	428V	Insert Screw
A560	-	429B	Low Baseplate with Rollers & Lip
	-	440R	Low Swivel Baseplate with Rollers & Lip
A562	-	436F	Roller Carrier Assembly, Low
A564	-	424DX	Standard - 6"
	-	424BX	Standard - 8"
	-	424GX	Standard - 10"
	-	424HX	Standard - 11"
	-	424MX	Standard - 14"
A565	-	430B	Lip, Low Baseplate
A566	-	427S	Screw, 10 x 3/8 Flat Hd. Socket
A568	-	431C	Axle, Low Baseplate
A571	-	433C	Spring, Low Lip
A579	-	302QB	Motor Cover, Sabre 2000
A580	-	23122B	Screw, 8-32 X 3/8" Low Head Socket
A581	-	23343	Washer, #8 Serrated Belleville (3)
	-	23345	Lockwasher, #8 External tooth (3)
A582	-	16660	Voltage Change Block, Sabre 2000 (optional)
	-	315AS	Screw 6-32 x 3/4" Fillister

**Always give machine SERIAL NUMBER when ordering parts.  
Order by PART NUMBER, not Key Number.**



**SUPPLEMENT PARTS SHEET FOR MAIMIN  
SABRE 2000 STRAIGHT KNIFE MACHINE  
ONLY FOR SERIAL NUMBERS BEGINNING WITH AP51, AP 61, OR AP71  
AND ENDING WITH -30123 OR HIGHER**

PARTS NOT ILLUSTRATED

Part Number	Description
429G	Lip Stop
10844	Screw, 10-32 x 5/16 Flat Hd.
402SC	Shim, Front Housing

**Always give machine SERIAL NUMBER when ordering parts.  
Order by PART NUMBER, not Key Number.**

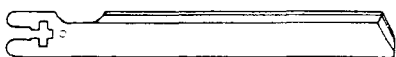
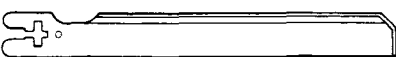
# BLADES AVAILABLE

Shape & Application	Grade	Quantity	Size & Part Number				
			6"	8"	10"	11"	14"
<b>REGULAR</b>  For general purpose cutting	BK	Dozen	30012	30014	30016	—	—
<b>LONG</b>  For hard or loosely woven materials, and general purpose cutting	ZKL	Each Dozen	30084 30085	30088 30089	30098 30099	30092 30093	30094 30095
	TK	Each Dozen	30344 30345	30348 30349	30356 30357	30352 30353	30354 30355
<b>TEFLON COATED</b>  For synthetics	ZKL	Each Dozen	30100 30101	30102 30103	30106 30107	— —	— —
<b>WAVE</b>  For synthetics and plastics	ZK	Each Dozen	30174 30175	30178 30179	— —	— —	— —

Note: There is a different part number for single blades and boxes of one dozen (12).  
**PLEASE ORDER BY PART NUMBER**

## H. MAIMIN CO., INC.

2915 COURTYARDS DR., BLDG. B, NORCROSS, GA 30071 USA  
 TEL: 770.447.1800, TOLL FREE USA: 800.243.4645, FAX: 770.447.1070  
 EMAIL: SALES@MAIMIN.COM