

1

2

3

4

5

6

A

A

B

B

C

C

D

D

E

E

F

F

VERSIONS		
VER	DESIGNER	DATE
A	LIXIN	2017-10-19
B	LIXIN	2017-11-29
C	LIXIN	2018-01-12
D		
E		
F		

(VIETMOBILE.VN)

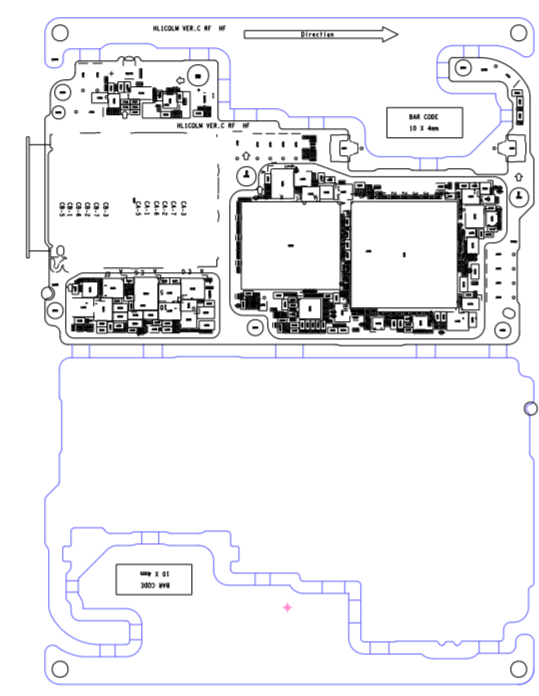

HL1COLM VER.C SILKSCREEN TOP
SPELL MODE:1*2

1

2

3

4

5

6

6

5

4

3

2

1

VERSIONS		
VER	DESIGNER	DATE
A	LIXIN	2017-10-19
B	LIXIN	2017-11-29
C	LIXIN	2018-01-12
D		
E		
F		

A

A

(VIETMOBILE.VN)

B

B

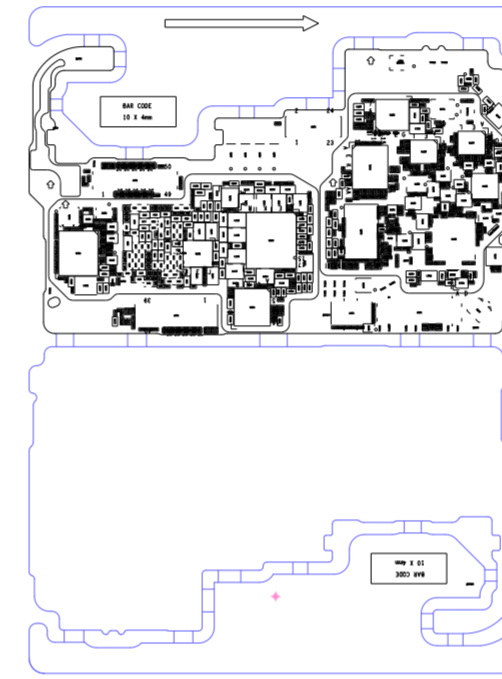

C

C

HL1COLM VER.C SILKSCREEN BOTM
 SPELL MODE:1*2

D

D

E

E

F

F

6

5

4

3

2

1

Baseband Schematic

1. Contents
2. RES
3. SOC PWR1
4. SOC PWR2
5. SOC PWR3
6. SOC HS INTERFACE
7. SOC GPIO INTERFACE1
8. SOC RF INTERFACE
9. SOC GND
10. Hi6421 LDO
11. Hi6421 BUCK AND Hi6423
12. Hi6421 DIGITAL INTERFACE
13. Hi6422V300
14. UFS and LPDDR4X
15. Battery & Fuel guage
16. Charge Management
17. LCD Interface
18. Flash/front Camera
19. M1/M2
20. USB
21. Main FPC/Wireless Power
22. CODEC HI6403
23. SC Charge
24. SPK SMART PA
25. MIC/REC/HAC/HIFI
26. Headphone
27. X-Sensor
28. SIM/uSD Card
29. LED/FP/Key
30. Test Points/Shields

MODEM Schematic

31. RF Interface
32. APT_LM3243
33. RFIC0_Hi6363
34. DPDT_Connector
35. TXM
36. MMBPA
37. TX_Loadpull
38. TRX_LB_1
39. TRX_LB_2
40. TRX_MB_1
41. TRX_MB_2
42. TRX_HB_1
43. TRX_HB_2
44. PRX_LNA_Module
45. DRX_SWITCH
46. DRX_LB
47. DRX_MB
48. DRX_HB
49. DRX_LNA_Module
50. Reserved
51. Reserved
52. Reserved
53. Reserved
54. Reserved
55. Reserved
56. Reserved
57. Reserved
58. Reserved
59. Reserved
60. NC_POWER
61. NC_BB
62. NC_FE_WIFI_2G
63. NC_FE_WIFI_5G
64. NC_GPS
65. RES
66. NFC Antena
67. RES
68. NFC_BB
69. RES
70. Antenna
71. NFC Antena

(VIETMOBILE.VN)

1

2

3

4

5

6

2.RES

A

A

B

B

C

C

D

D

1

2

3

4

5

6

3.SOC PWR1

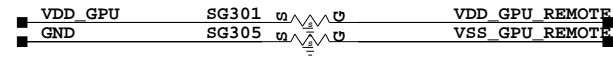
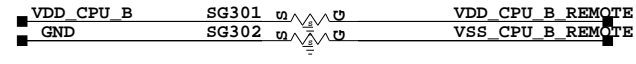

3) uF, C306#C301#C326の配線に注意
 4) uF, C310#C322#C325#C323の配線に注意
 6) 0uFの配線に注意

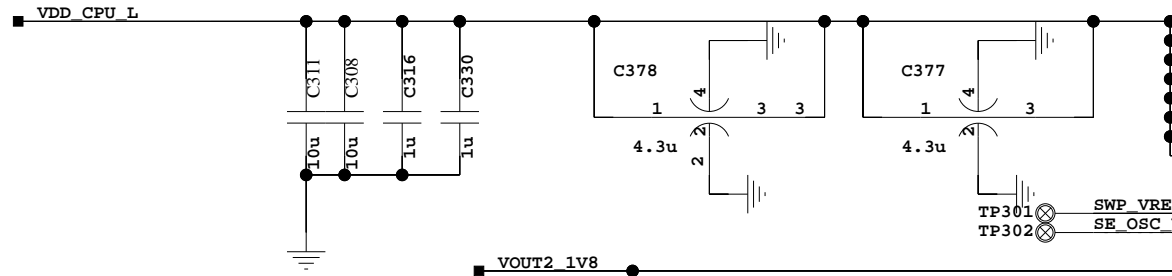
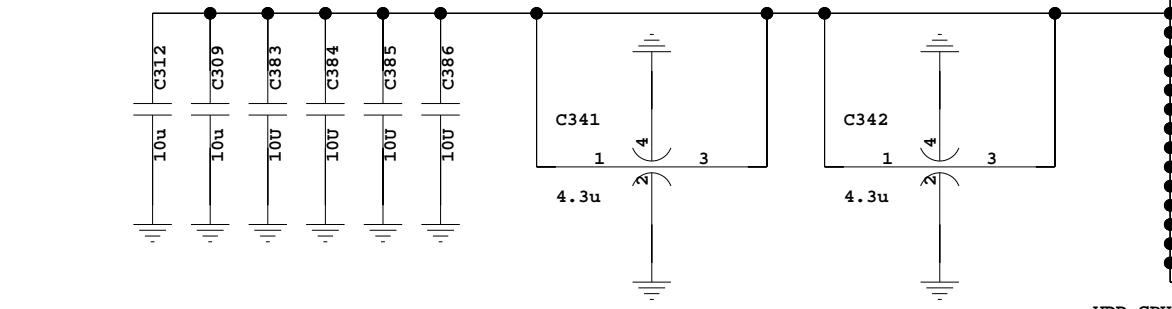
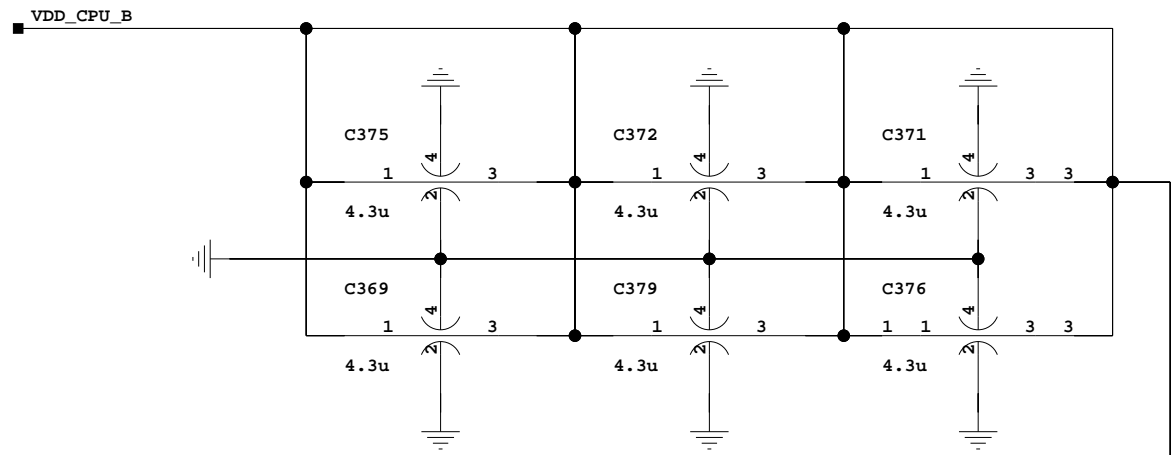

PWR1 interface 1 of 10

U300 HI3670CSSOC		GPU	
CPU BIG		GPU	
AJ12	VDD_CPU_B_1	AU36	VDD_GPU_1
AJ14	VDD_CPU_B_2	AA28	VDD_GPU_2
AJ16	VDD_CPU_B_3	AA30	VDD_GPU_3
AJ18	VDD_CPU_B_4	AA32	VDD_GPU_4
AJ20	VDD_CPU_B_5	AA34	VDD_GPU_5
AN10	VDD_CPU_B_6	AA36	VDD_GPU_6
AN12	VDD_CPU_B_7	AA40	VDD_GPU_7
AN14	VDD_CPU_B_8	AE28	VDD_GPU_8
AN16	VDD_CPU_B_9	AE32	VDD_GPU_9
AN20	VDD_CPU_B_10	AE34	VDD_GPU_10
AU10	VDD_CPU_B_11	AE36	VDD_GPU_11
AU14	VDD_CPU_B_12	AE40	VDD_GPU_12
AU16	VDD_CPU_B_13	AJ28	VDD_GPU_13
AU18	VDD_CPU_B_14	AJ32	VDD_GPU_14
CPU PLL		AJ34	VDD_GPU_15
CPU LITTLE		AJ36	VDD_GPU_16
AL24	VDD_CPU_L_1	AJ38	VDD_GPU_17
AL26	VDD_CPU_L_2	AJ40	VDD_GPU_18
AR22	VDD_CPU_L_3	AN30	VDD_GPU_19
AR24	VDD_CPU_L_4	AN32	VDD_GPU_20
AR26	VDD_CPU_L_5	AN34	VDD_GPU_21
AU22	VDD_CPU_L_6	AU40	VDD_GPU_22
AU24	VDD_CPU_L_7	AU32	VDD_GPU_23
AU26	VDD_CPU_L_8	AU34	VDD_GPU_24
SWP		AU38	VDD_GPU_25
TP301	SWP_VREF BH35	AU32	VDD_GPU_26
TP302	SE_OSC_VREFBH17	AU34	VDD_GPU_27
AVDD18_OTP		AE30	VDDC_GPU_MEM_1
AY21	AVDD18_OTP	AE38	VDDC_GPU_MEM_2
EFUSE		AL30	VDDC_GPU_MEM_3
BA40	VDD18_EFUSE_BISR	AN38	VDDC_GPU_MEM_4
AY39	VDD18_EFUSE_SYS	AU30	VDDC_GPU_MEM_5
GPU Tsensor		AU38	VDDC_GPU_MEM_6
AW40	AVDD18_TS_GPU	AJ30	VDDC_GPU_MEM_7
VDD_GPU_T		AL40	VDD_GPU_T
VSS_GPU_T		AN40	VSS_GPU_T

AP Temperature DET

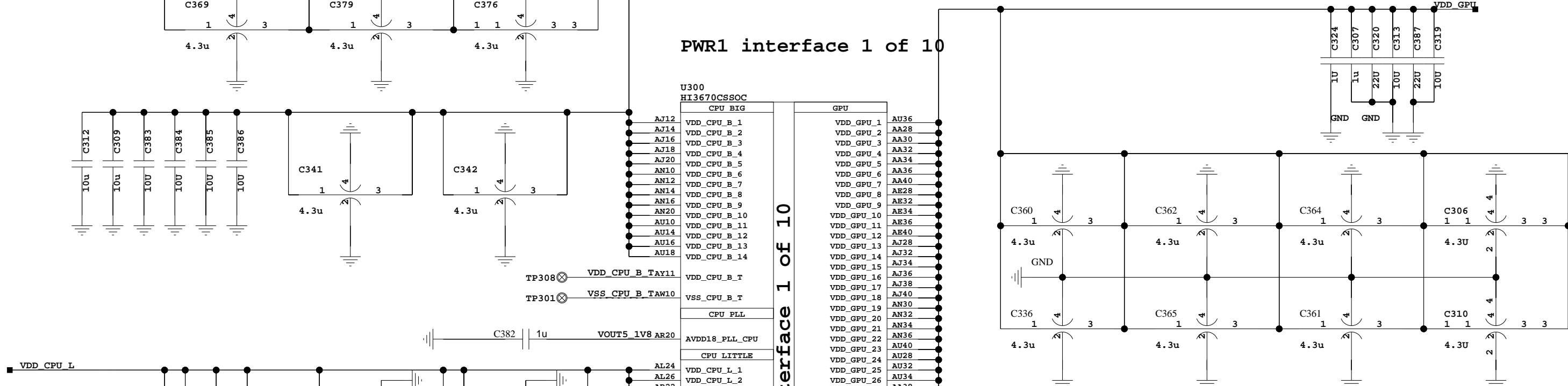
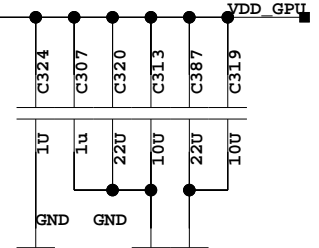
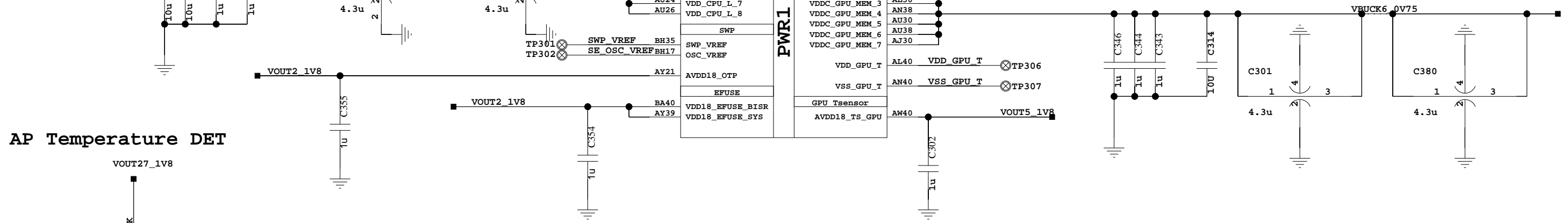
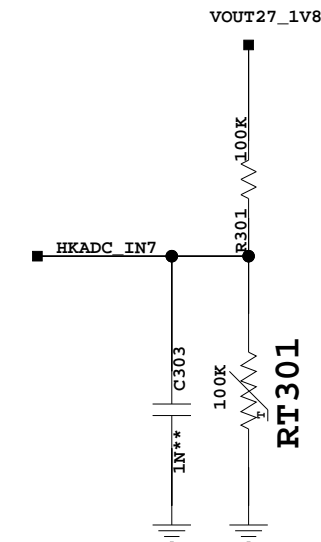

4.SOC PWR2

PWR2 interface 2 of 10

Ensure VBUCK1_1V1_FB_R and VBUCK7_0V6_FB_R near the CAP

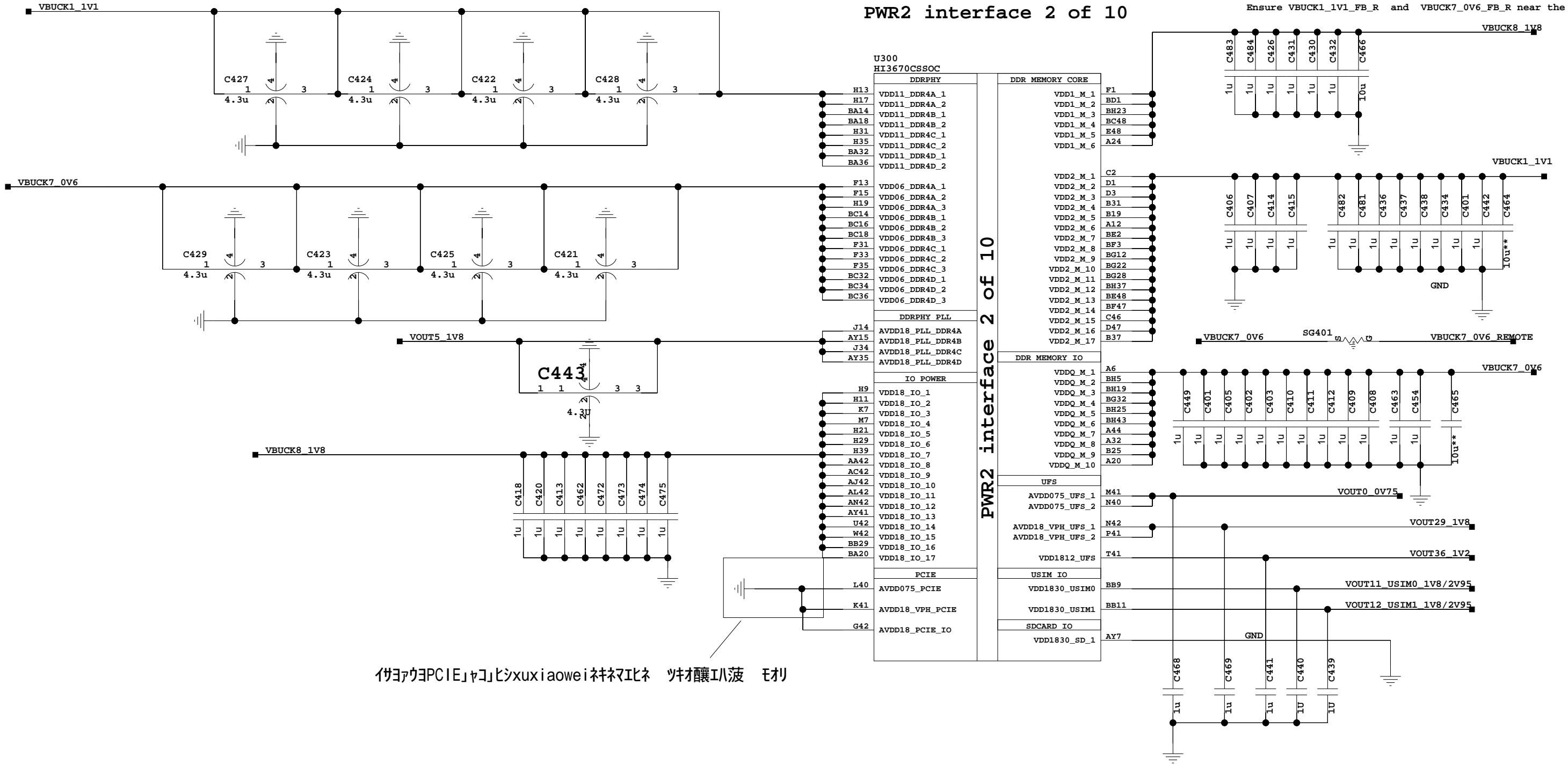

付ヨウヨPCIE「ヤコ」ビシxuxiaoweいネネマリネ ツク醸工八波 モリ

5.SOC PWR3

PWR3 interface 3 of 10

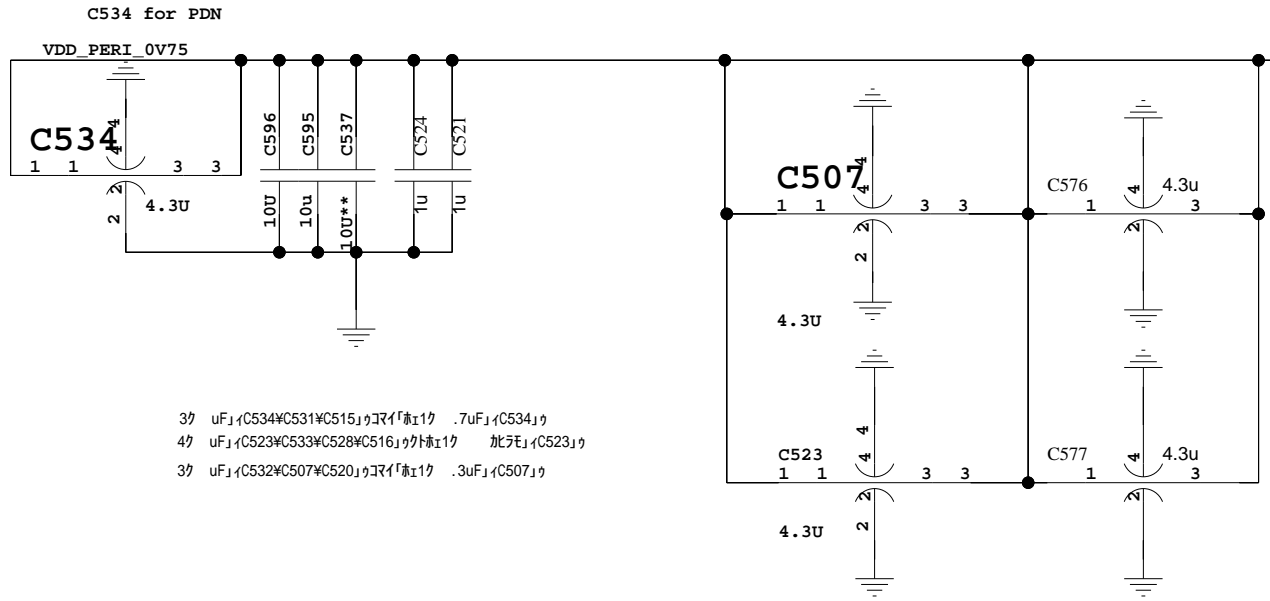
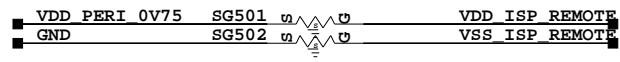

37 uF(C534/C531/C515)の配線は17 .7uF(C534)の
 47 uF(C523/C533/C528/C516)の配線は17 加えてC523の
 37 uF(C532/C507/C520)の配線は17 .3uF(C507)の

U300 HI3670CSSOC	
PERI CORE	MODEM
AC20	VDD075_PERI_1
AC22	VDD075_PERI_2
AC24	VDD075_PERI_3
AC26	VDD075_PERI_4
AG20	VDD075_PERI_5
AG22	VDD075_PERI_6
AL22	VDD075_PERI_7
AN22	VDD075_PERI_8
AN28	VDD075_PERI_9
AT41	VDD075_PERI_10
AY27	VDD075_PERI_11
BA42	VDD075_PERI_12
J8	VDD075_PERI_13
L20	VDD075_PERI_14
L22	VDD075_PERI_15
L24	VDD075_PERI_16
L26	VDD075_PERI_17
L28	VDD075_PERI_18
L30	VDD075_PERI_19
L32	VDD075_PERI_20
L34	VDD075_PERI_21
L36	VDD075_PERI_22
N8	VDD075_PERI_23
R20	VDD075_PERI_24
R22	VDD075_PERI_25
R24	VDD075_PERI_26
R26	VDD075_PERI_27
R28	VDD075_PERI_28
R30	VDD075_PERI_29
R32	VDD075_PERI_30
R34	VDD075_PERI_31
R36	VDD075_PERI_32
W20	VDD075_PERI_33
W22	VDD075_PERI_34
W24	VDD075_PERI_35
W26	VDD075_PERI_36
W28	VDD075_PERI_37
W30	VDD075_PERI_38
W32	VDD075_PERI_39
W34	VDD075_PERI_40
AY17	VDD075_PERI_41
AW20	VDD075_PERI_42
DDR CORE	
J12	VDD075_PERI_43
J18	VDD075_PERI_44
J30	VDD075_PERI_45
J36	VDD075_PERI_46
AY13	VDD075_PERI_47
AY19	VDD075_PERI_48
AY31	VDD075_PERI_49
AY37	VDD075_PERI_50
PERI FIX PLL	
AV9	VDD075_PERI_FIX_1
AV9	VDD075_PERI_FIX_2
K39	VDD075_PERI_FIX_3
AY25	VDD075_PERI_FIX_4
J24	VDD075_PERI_FIX_5
PERI PLL	
J40	AVDD075_PLL_FIX
H41	AVDD18_PLL_FIX
MIPI	
H23	AVDD18_CSI_1
H25	AVDD18_CSI_2
BA24	AVDD18_DSI_1
BA26	AVDD18_DSI_2
SYS CORE	
AD41	VDD075_SYS_1
AE24	VDD075_SYS_2
AH41	VDD075_SYS_3
AM41	VDD075_SYS_4
N38	VDD075_SYS_5
R38	VDD075_SYS_6
U40	VDD075_SYS_7
W40	VDD075_SYS_8
SYS PLL	
U38	AVDD075_PLL_SYS
W38	AVDD18_PLL_SYS
PI Monitor	
BA22	PI_VREF

PWR3 interface 3 of 10

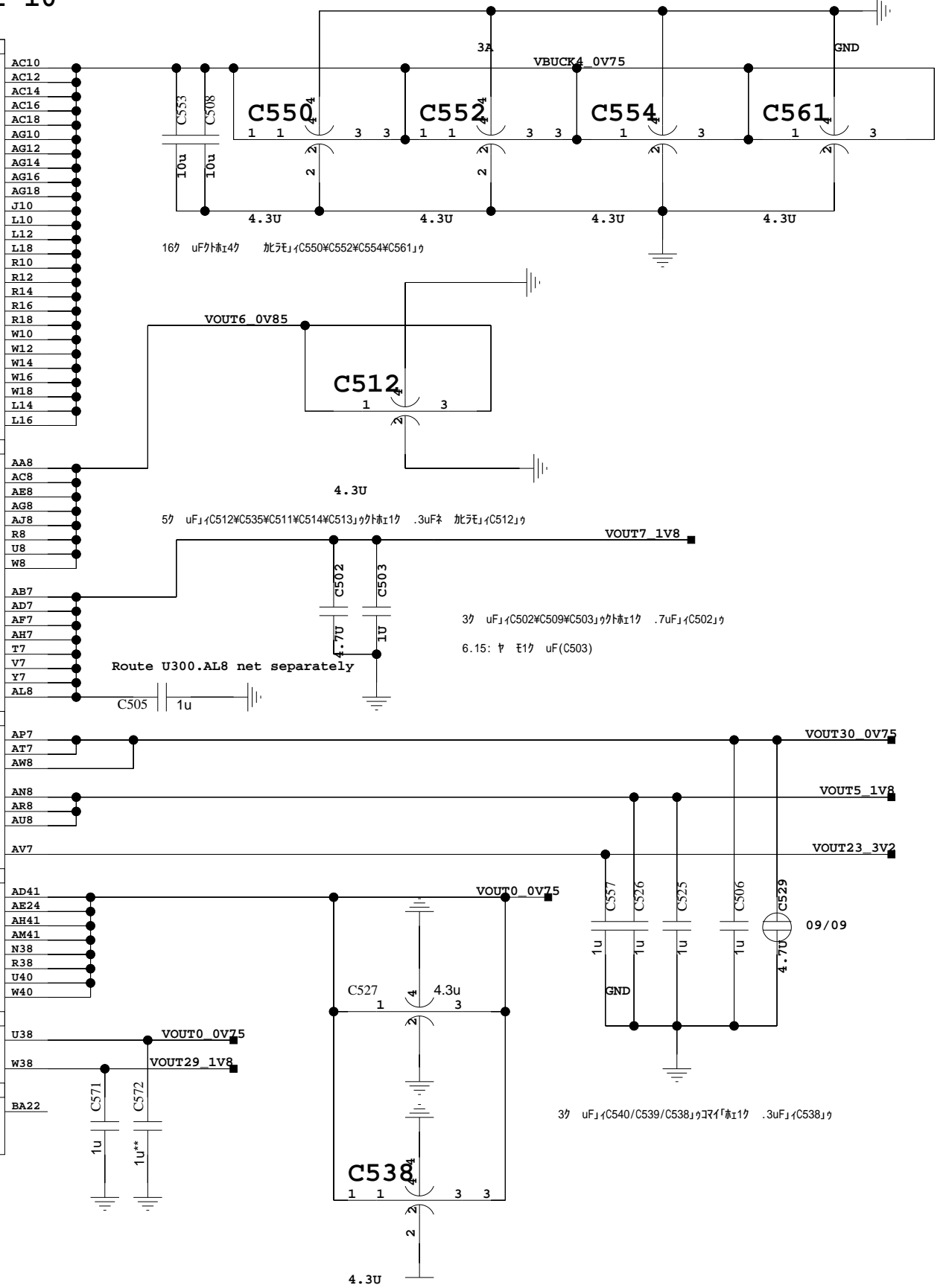

167 uF(外付)の配線は17 加えてC550/C552/C554/C561の

57 uF(C512/C535/C511/C514/C513)の配線は17 .3uF(加えてC512)の

37 uF(C502/C509/C503)の配線は17 .7uF(C502)の
 6.15: 7 17 uF(C503)

Route U300.AL8 net separately

09/09

37 uF(C540/C539/C538)の配線は17 .3uF(C538)の

ツボカマノPCIEノコトヒシxuxiaoweiノネネヒネ ツボカマノ波 ノカ

6.SOC HS INTERFACE

U300

HI3670CSOC

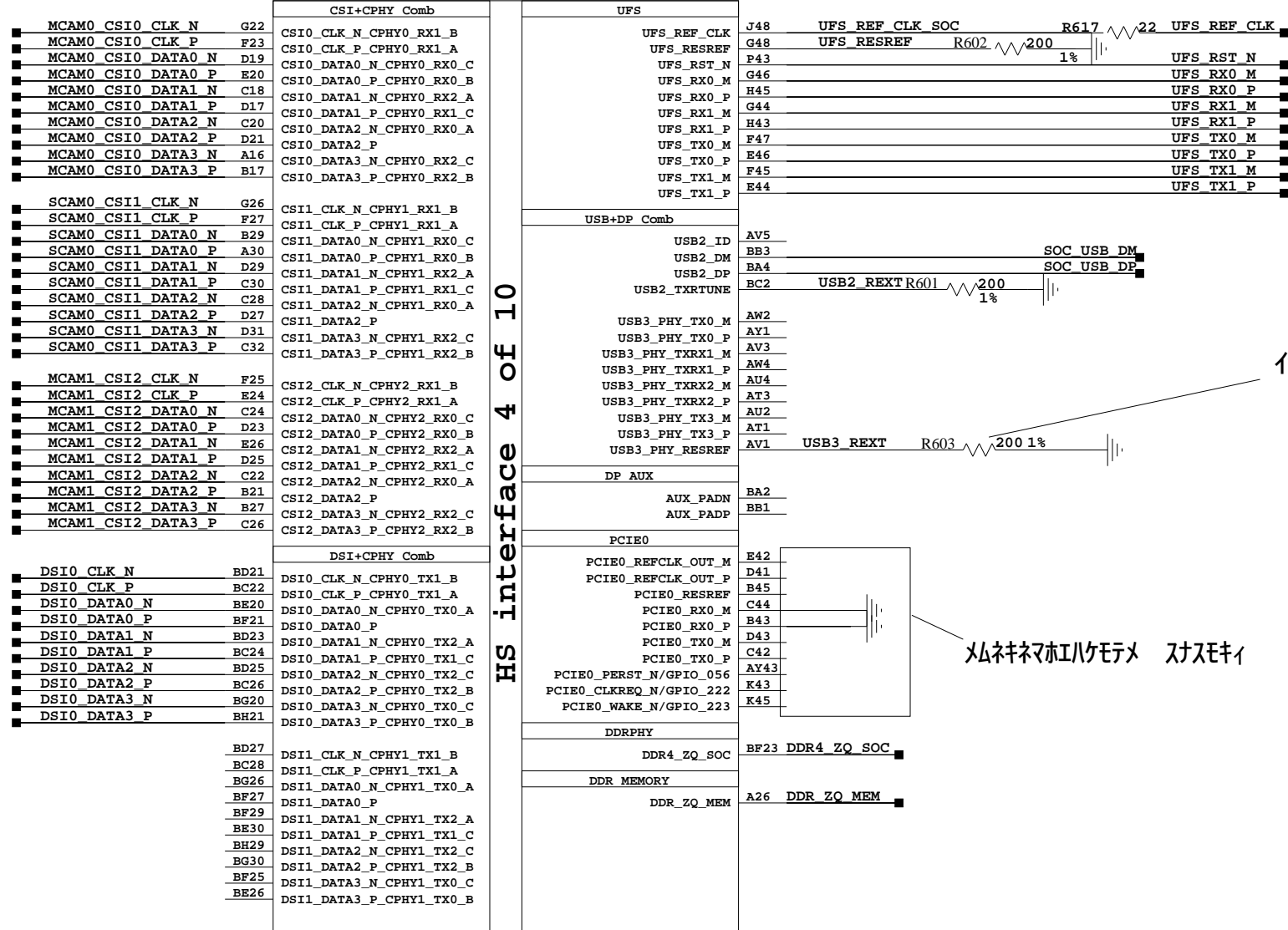

イサヨアウヨUSB3.1「ヤコ」ビスイメ魔ヒメ スナチャスモア「チ

ムネキネマホエハケテメ スナスモキ

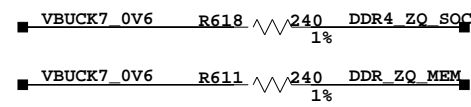

7.SOC GPIO INTERFACE1

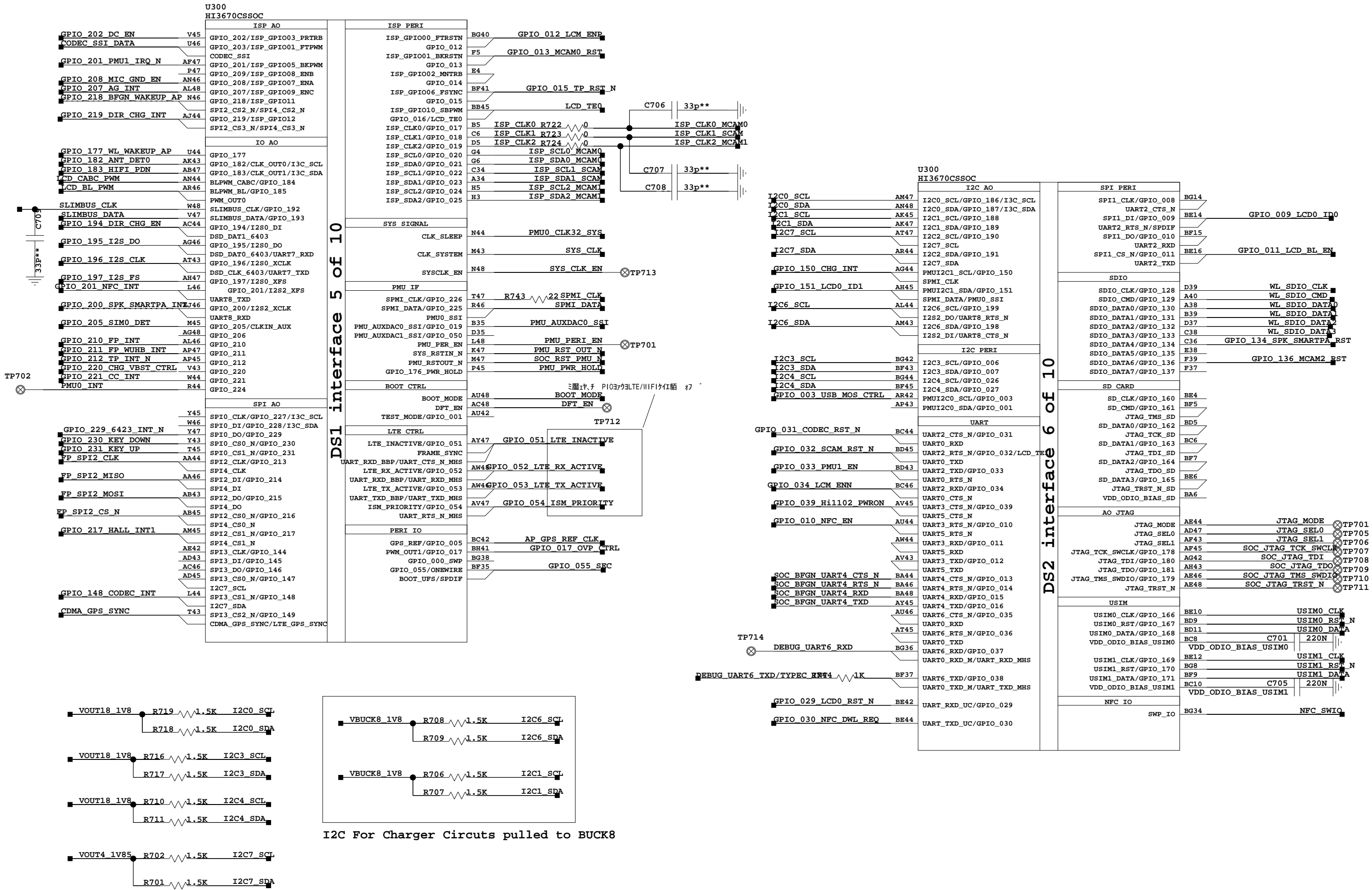

8.SOC RF INTERFACE

U300
HI3670CSSOC

RF IQ	
CH0 MRX I	AF5
CH0 MRX Q	AE4
CH0 RXA I	AL2
CH0 RXA Q	AK1
CH0 RXB I	AK5
CH0 RXB Q	AJ6
CH1 RXA I	AJ4
CH1 RXA Q	AH5
CH1 RXB I	AH3
CH1 RXB Q	AG2
CH4 RXA I	AE2
CH4 RXA Q	AF1
CH4 RXB I	AF3
CH4 RXB Q	AG4
CH0 TX I N	AC4
CH0 TX I P	AB5
CH0 TX Q N	AD5
CH0 TX Q P	AE6
	AB1
	AC2
	AA4
	AB3

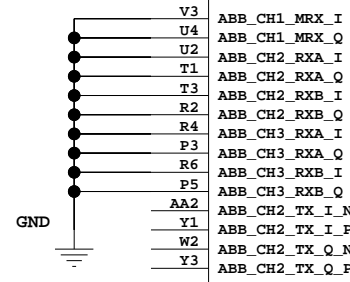

RF CTRL	
ABB_CLK_38M4	AM5
GMSK_PH0	BG16

ET	
	AA6
	Y5
	V5
	W4

RF MIPI	
FE0 MIPI_CLK	B13
FE0 MIPI_DATA	C14
FE1 MIPI_CLK	B15
FE1 MIPI_DATA	A14
	D15
	D13
RFIC0 MIPI_CLK	A8
RFIC0 MIPI_DATA	C8

ANT SEL	
ANTPA_SEL00/GPIO_057	BF39
GPS_BLANKING	
ANTPA_SEL01/GPIO_058	BE36
FLASH_MASK	
ANTPA_SEL02/GPIO_059	J6
GMSK_PH1	K5
ANTPA_SEL03/GPIO_060	
FE6_MIPI_CLK	
ANTPA_SEL01/GPIO_061	K3
ANTPA_SEL05/GPIO_062	
FE6_MIPI_DATA/CH2_APT_PDM	
ANTPA_SEL06/GPIO_063	L2
FE5_MIPI_CLK/RFIC1_MIPI_CLK	
CH0_APT_PDM	
ANTPA_SEL07/GPIO_064	BE18
ANTPA_SEL08/GPIO_065	BF17
ANTPA_SEL09/GPIO_066	BE32
ANTPA_SEL10/GPIO_067	BF33
ANTPA_SEL11/GPIO_068	BE34
ANTPA_SEL12/GPIO_069	BD39
ANTPA_SEL13/GPIO_070	BE40
ANTPA_SEL14/GPIO_071	BE38
ANTPA_SEL15/GPIO_072	G2
ANTPA_SEL16/GPIO_073	H1
ANTPA_SEL17/GPIO_074	J4
ANTPA_SEL18/GPIO_075	J2
ANTPA_SEL19/GPIO_076	D9
FE6_MIPI_CLK	
ANTPA_SEL20/GPIO_077	C10
FE6_MIPI_DATA	
ANTPA_SEL21/GPIO_078	E10
FE5_MIPI_CLK	
ANTPA_SEL22/GPIO_079	F9
FE5_MIPI_DATA	
ANTPA_SEL23/GPIO_080	L6
FE4_MIPI_CLK	
ANTPA_SEL24/GPIO_081	L4
FE4_MIPI_DATA/CH2_APT_PDM	
ANTPA_SEL25/GPIO_082	A10
FE3_MIPI_CLK/RFIC1_MIPI_CLK	B9
ANTPA_SEL26/GPIO_083	
FE3_MIPI_DATA/RFIC1_MIPI_DATA	
ANTPA_SEL27/GPIO_084	F11
FE4_MIPI_CLK	
ANTPA_SEL28/GPIO_085	D11
FE4_MIPI_DATA	
ANTPA_SEL29/GPIO_086	F7
FE3_MIPI_CLK	
ANTPA_SEL30/GPIO_087	E8
FE3_MIPI_DATA	

RF interface 7 of 10

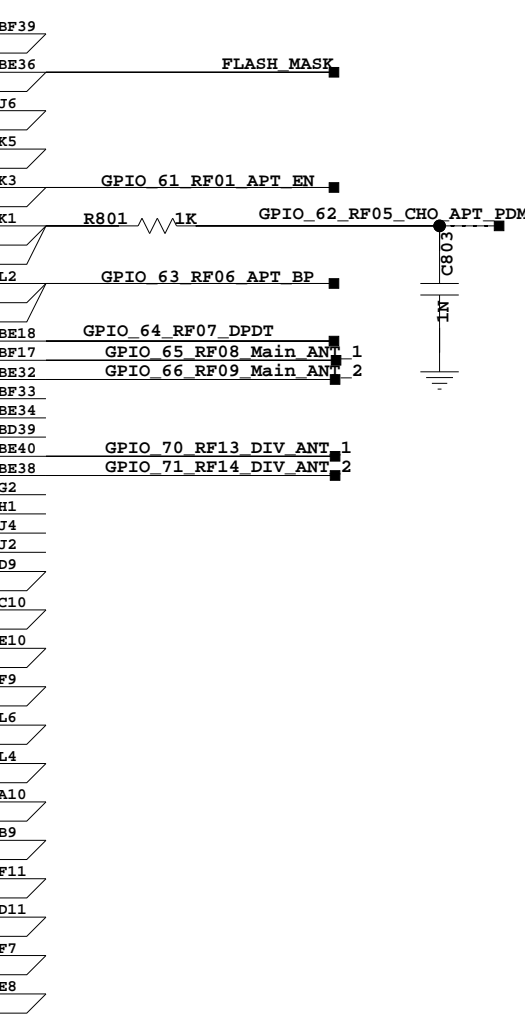

9.SOC GND

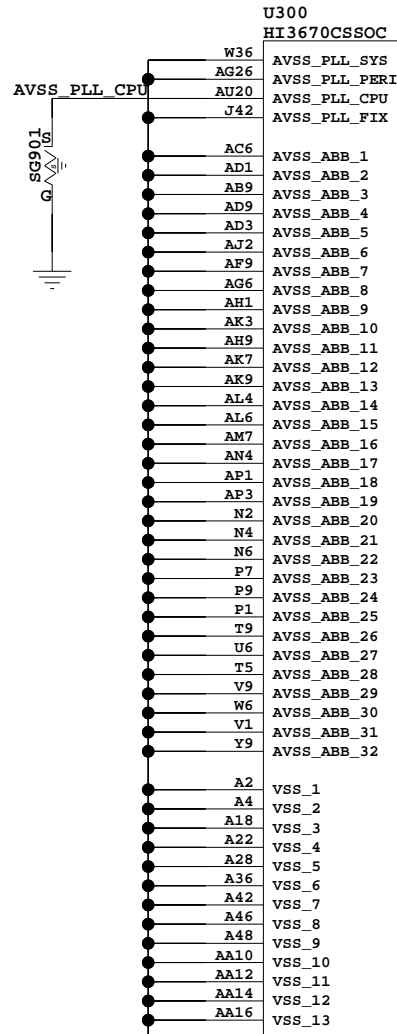

GND1 interface 8 of 10

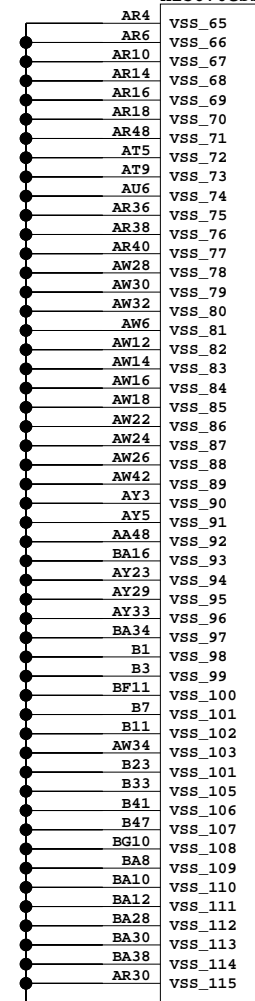
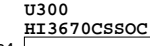
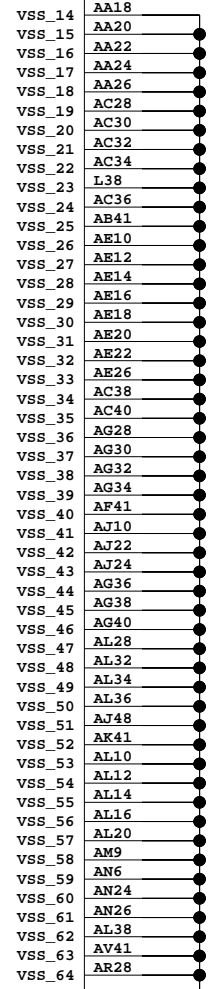

GND2 interface 9 of 10

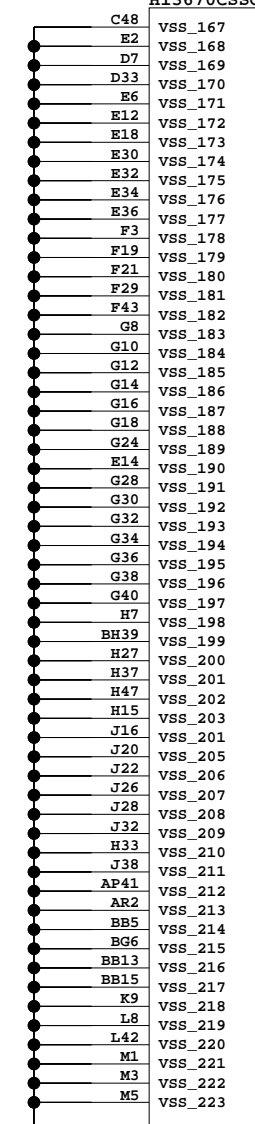
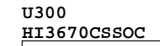
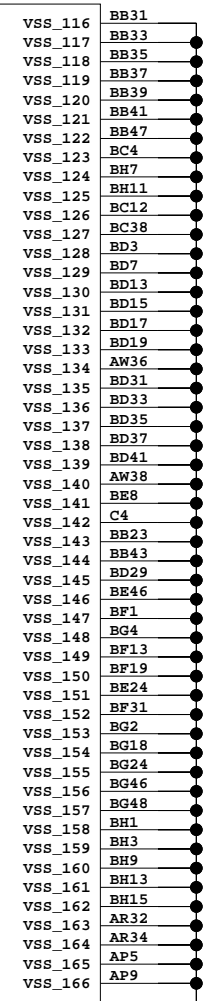

GND3 interface 10 of 10

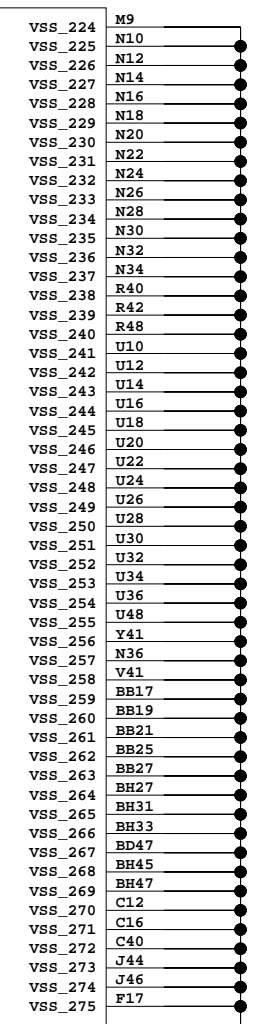

GND

10. Hi6421 LDO

NUM	Vol	Current	Function
LDO0	0.75	300	SOC:UFS,SYS,PLL_SYS
LDO1	1.09	350	RFIC0 AVDD10
LDO2	1.8	120	SOC_EFUSE&HISEE
LDO3	1.8	360	RFIC AVDD18,LNA_VDD
LDO4	1.85	350	LCD&TP 1.8V IO
LDO5	1.8	350	SOC 1.8V AVDD
LDO6	0.85	550	SOC:AVDD085_ABB
LDO7	1.8	350	SOC:AVDD18_ABB
LDO8	1.8	250	IOVDD FOR Codec/RF
LDO9	1.8	50	SOC SDIO 1.8V
LDO11	1.8/2.95	50	SIM0
LDO12	1.8/2.95	50	SIM1
LDO13	2.8	150	CAM_AVDD
LDO14	2.85	50	RF switch VDD
LDO15	2.95	800	UFS_VCC
LDO16	2.95	800	SDCARD VDD
LDO17	3.3	200	MCAM_AFVDD1
LDO18	1.8	400	PERI IOVDD
LDO19	1.2	400	MCAM_DVDD0
LDO20	1.1	400	MCAM_DVDD1
LDO21	1.8	180	CAM IOVDD
LDO22	1.09	350	RESEVERD
LDO23	3.2	150	USB 2.0 PHY/PA
LDO24	2.8	200	Sensor VDD
LDO25	2.85	150	MCAM_AFVDD0
LDO26	1.7	30	38.4MHZ XO CORE
LDO27	1.8	30	HKADC,XOADC
LDO28	1.8	120	RF switch VIO
LDO29	1.8	120	VPH_UFS,PLL_SYS
LDO30	0.75	400	FIX 0.75 For SOC
LDO32	1.1	400	SlaveCAM_DVDD
LDO33	2.8	150	MCAM_AVDD0
LDO34	3.3	200	FP VDD
LDO35	2.9	50	CODEC_AVDD
LDO36	1.2	10	UFS refclk/rst IO

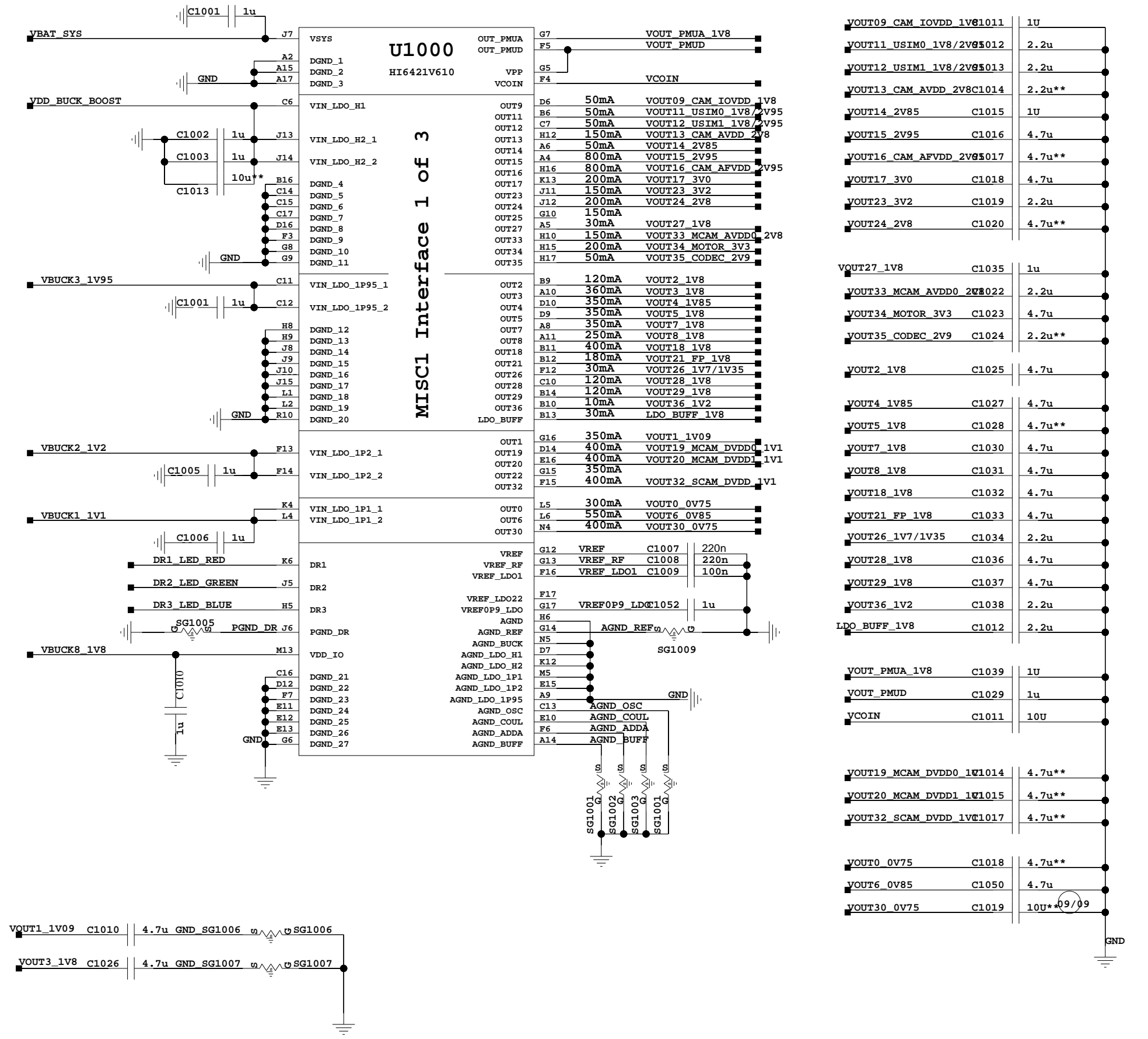

VOUT09 CAM IOVDD 1V8	C1011	1u
VOUT11 USIM0 1V8/2V95	C1012	2.2u
VOUT12 USIM1 1V8/2V95	C1013	2.2u
VOUT13 CAM AVDD 2V8	C1014	2.2u**
VOUT14 2V85	C1015	1u
VOUT15 2V95	C1016	4.7u
VOUT16 CAM AFVDD 2V95	C1017	4.7u**
VOUT17 3V0	C1018	4.7u
VOUT23 3V2	C1019	2.2u
VOUT24 2V8	C1020	4.7u**
VOUT27 1V8	C1035	1u
VOUT33 MCAM AVDD0 2V8	C1022	2.2u
VOUT34 MOTOR 3V3	C1023	4.7u
VOUT35 CODEC 2V9	C1024	2.2u**
VOUT2 1V8	C1025	4.7u
VOUT4 1V85	C1027	4.7u
VOUT5 1V8	C1028	4.7u**
VOUT7 1V8	C1030	4.7u
VOUT8 1V8	C1031	4.7u
VOUT18 1V8	C1032	4.7u
VOUT21 FP 1V8	C1033	4.7u
VOUT26 1V7/1V35	C1034	2.2u
VOUT28 1V8	C1036	4.7u
VOUT29 1V8	C1037	4.7u
VOUT36 1V2	C1038	2.2u
LDO_BUFF 1V8	C1012	2.2u
VOUT_PMUA 1V8	C1039	1u
VOUT_PMUD	C1029	1u
VCOIN	C1011	10u
VOUT19 MCAM DVDD0 1V1	C1014	4.7u**
VOUT20 MCAM DVDD1 1V1	C1015	4.7u**
VOUT32 SCAM DVDD 1V1	C1017	4.7u**
VOUT0 0V75	C1018	4.7u**
VOUT6 0V85	C1050	4.7u
VOUT30 0V75	C1019	10u**09/09

11.Hi6421 BUCK AND Hi6423

Hi6423

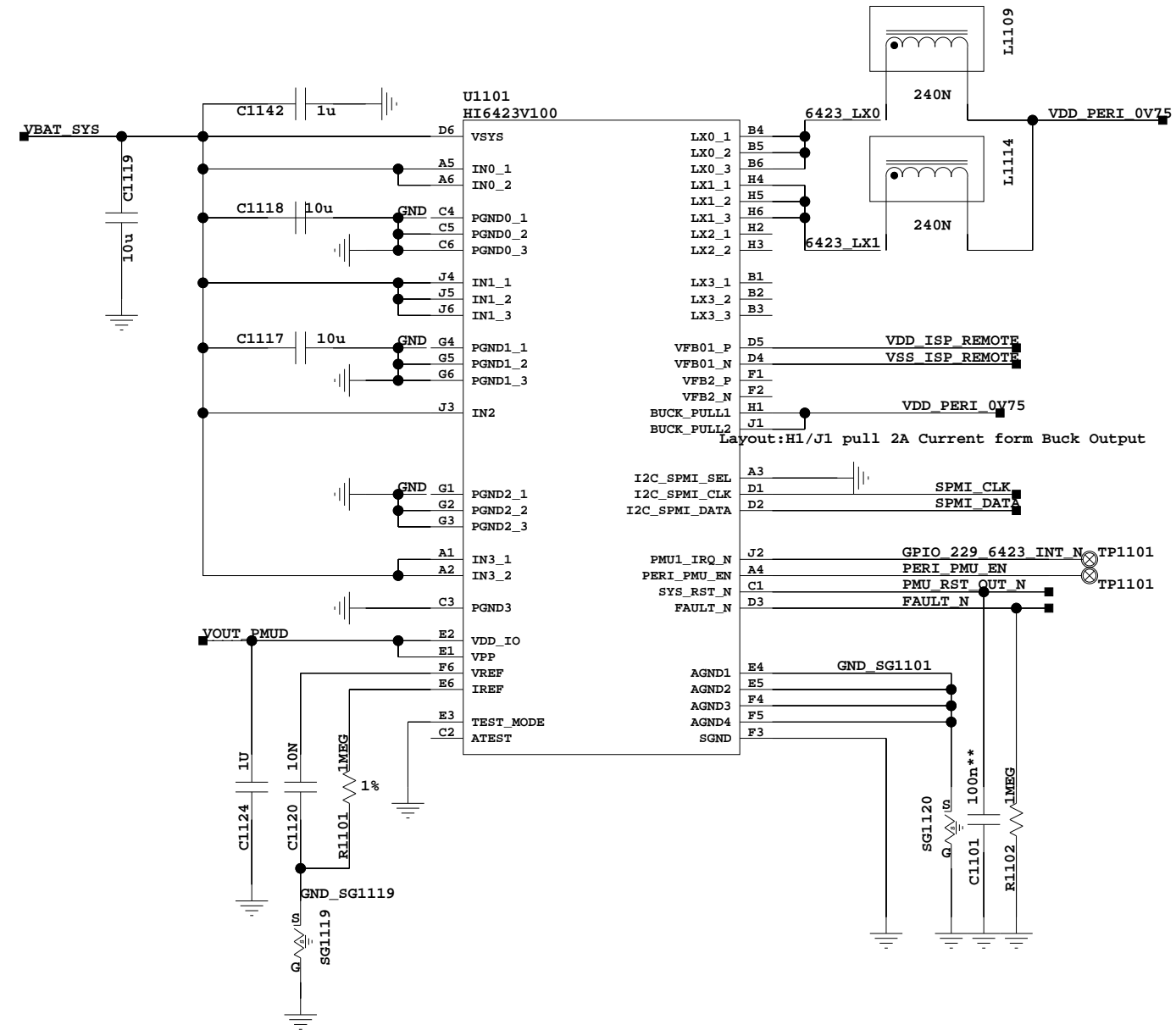
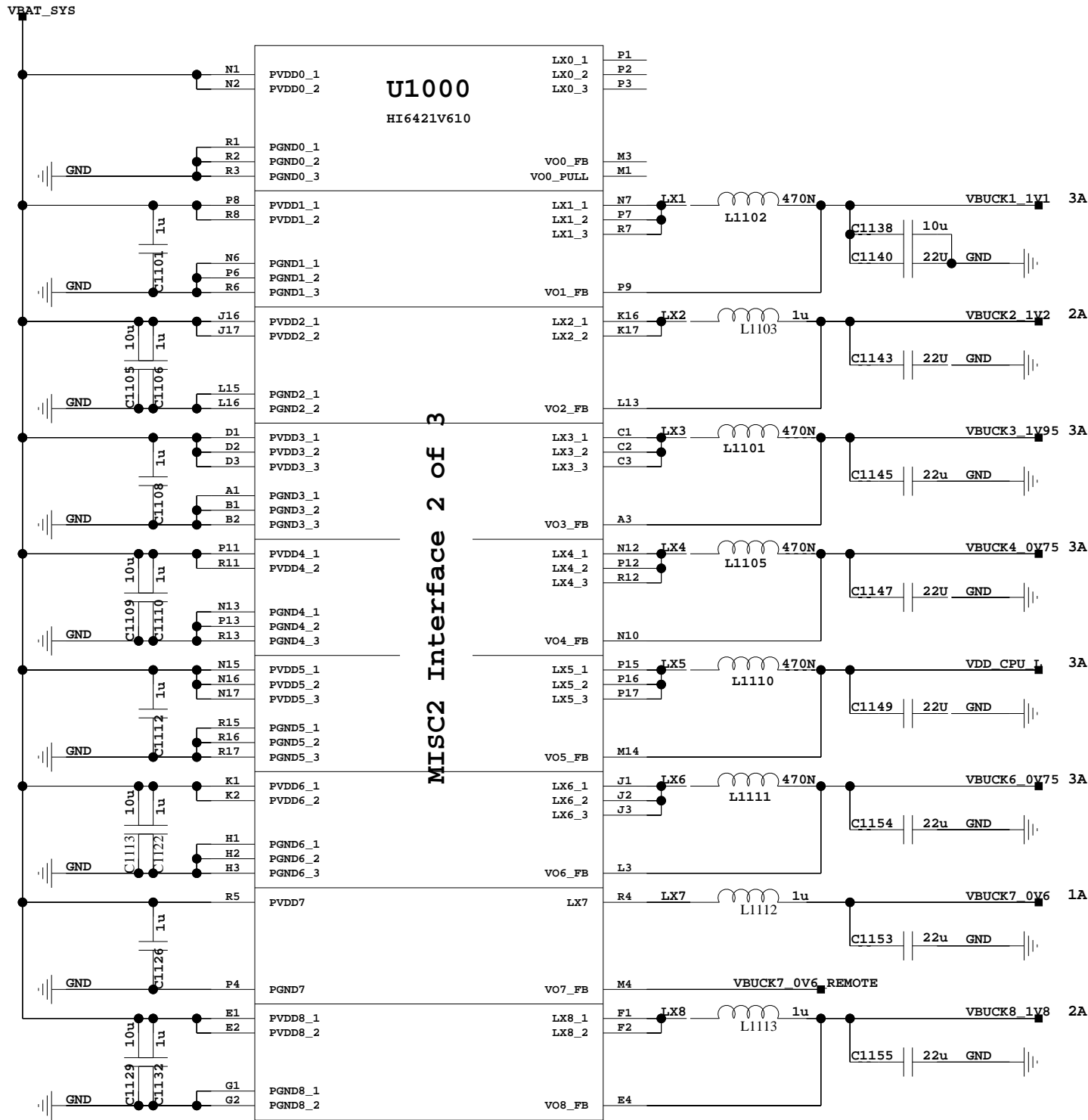

Layout:H1/J1 pull 2A Current form Buck Output

12.Hi6421 DIGITAL INTERFACE

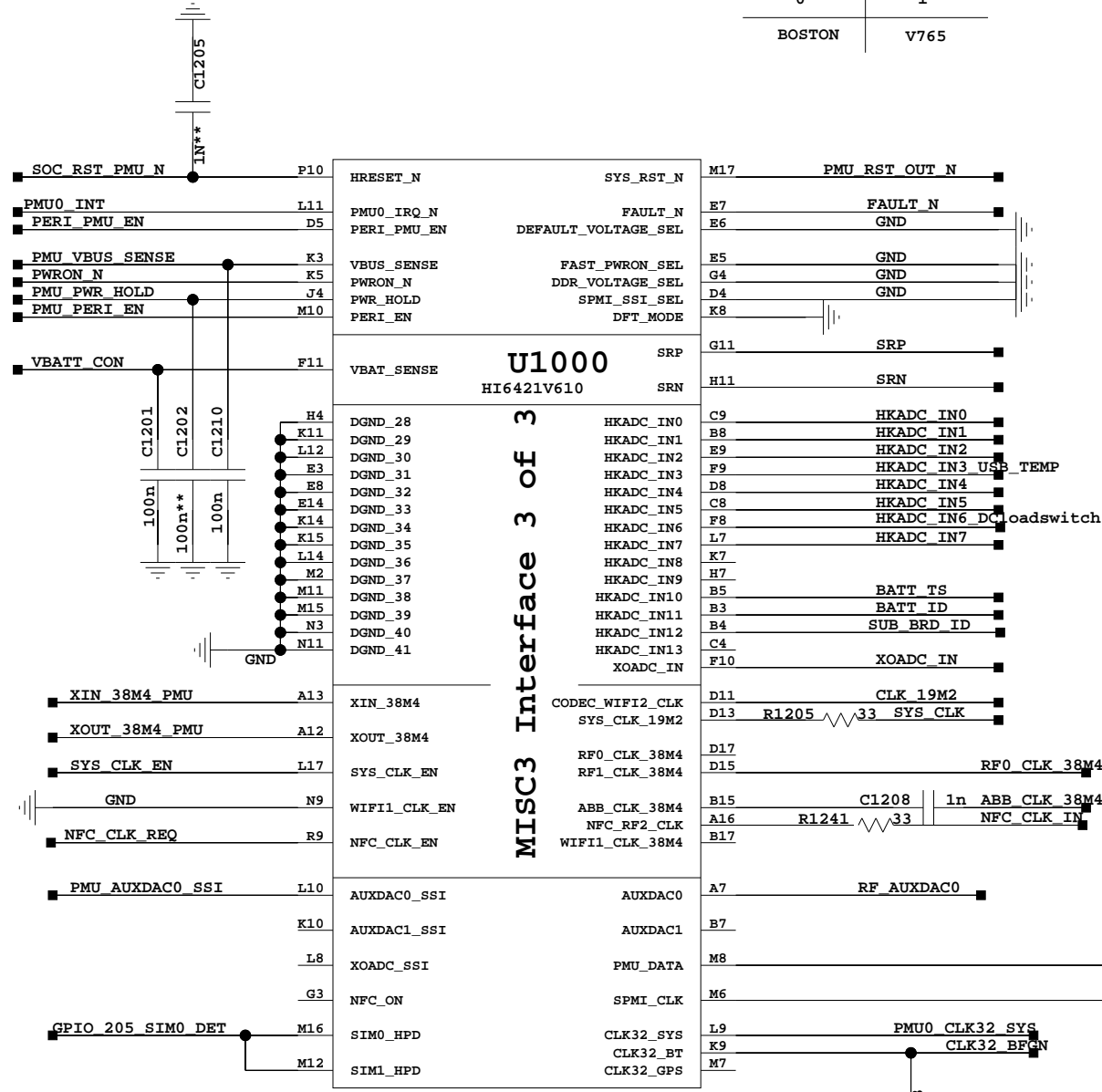

MISC3 Interface 3 of 3

DEFAULT_VOLTAGE_SEL	
0	1
BOSTON	V765

FAST_PWRON_SEL	
0	1
NORMAL	FAST

DDR_VOLTAGE_SEL	
0	1
LPDDR4x	LPDDR3

SPMI_SSI_SEL	
0	1
SPMI	SSI

HKADC IN0	APU Board ID0
HKADC IN1	APU Board ID1
HKADC IN2	APU Board ID2
HKADC IN3	TypeC TEMP
HKADC IN4	RFIC0 TEMP
HKADC IN5	Charge TEMP
HKADC IN6	DCloadswitch TEMP
HKADC IN7	AP TEMP
HKADC IN8	RESERVED
HKADC IN9	RFIC1 TEMP
HKADC IN10	BATT TEMP
HKADC IN11	BATT ID
HKADC IN12	RESERVED
HKADC IN13	RESERVED

BUCK BOOST

$$V_{out} = 0.8 * (1 + R1/R2) = 3.467V$$

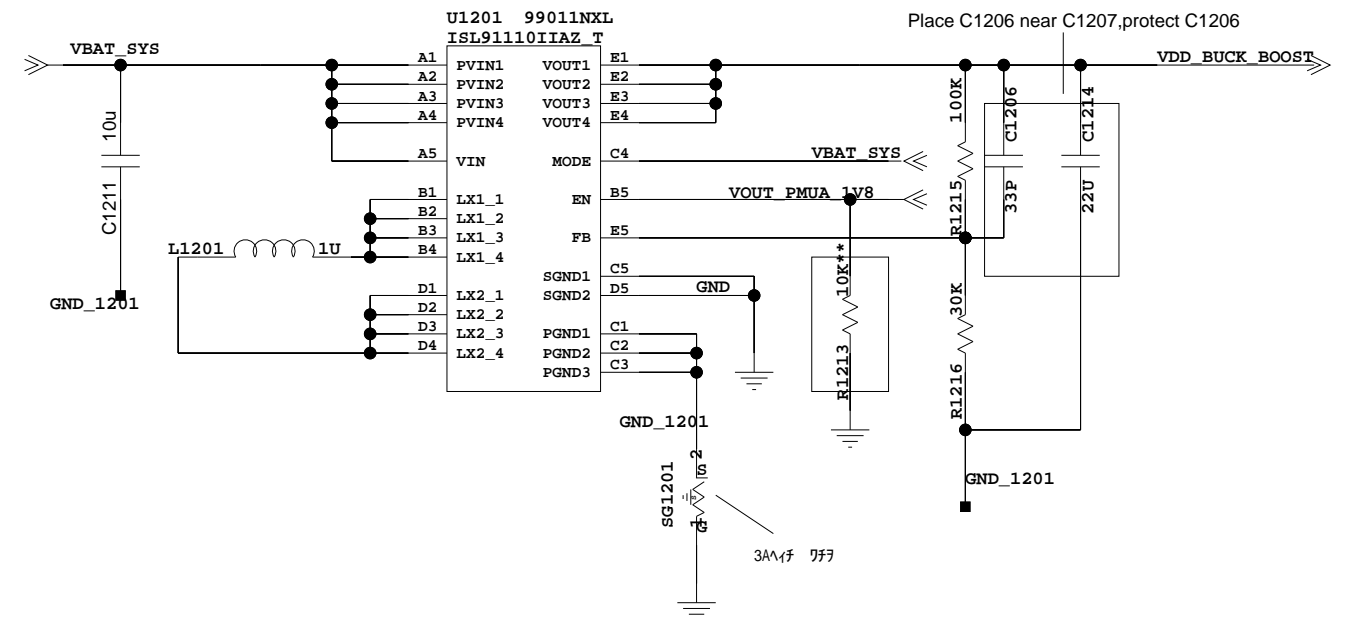

BOARD ID Table

Board ID	HKADC2	HKADC1	HKADC0
V1			
V3			

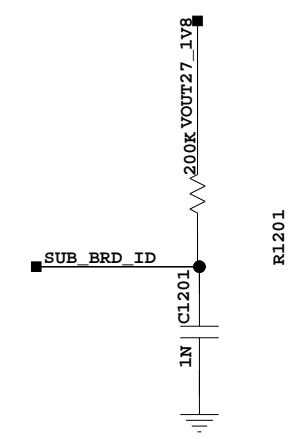
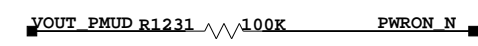
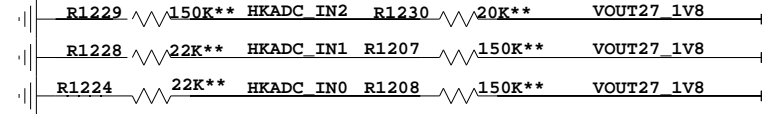

DCXO

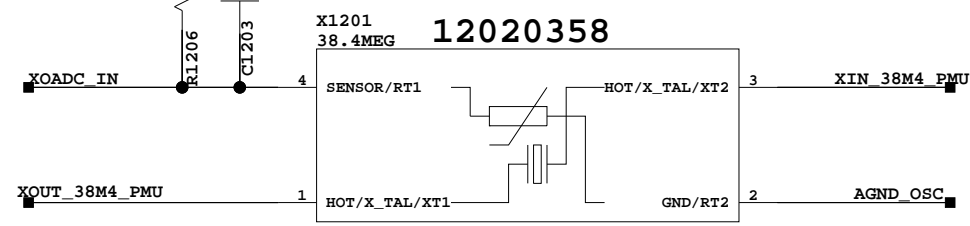

13.Hi6422V300

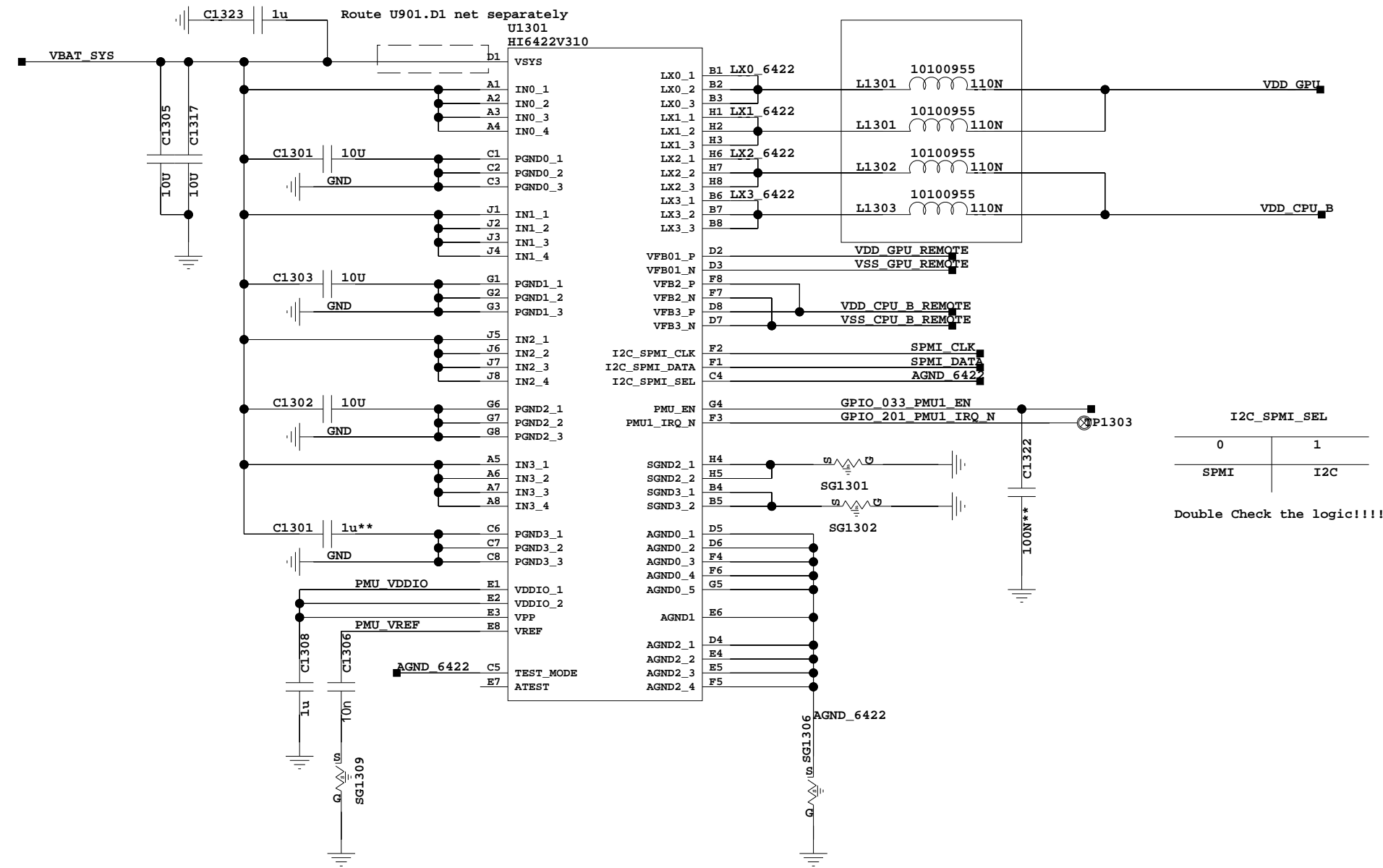

14.UFS and LPDDR4X

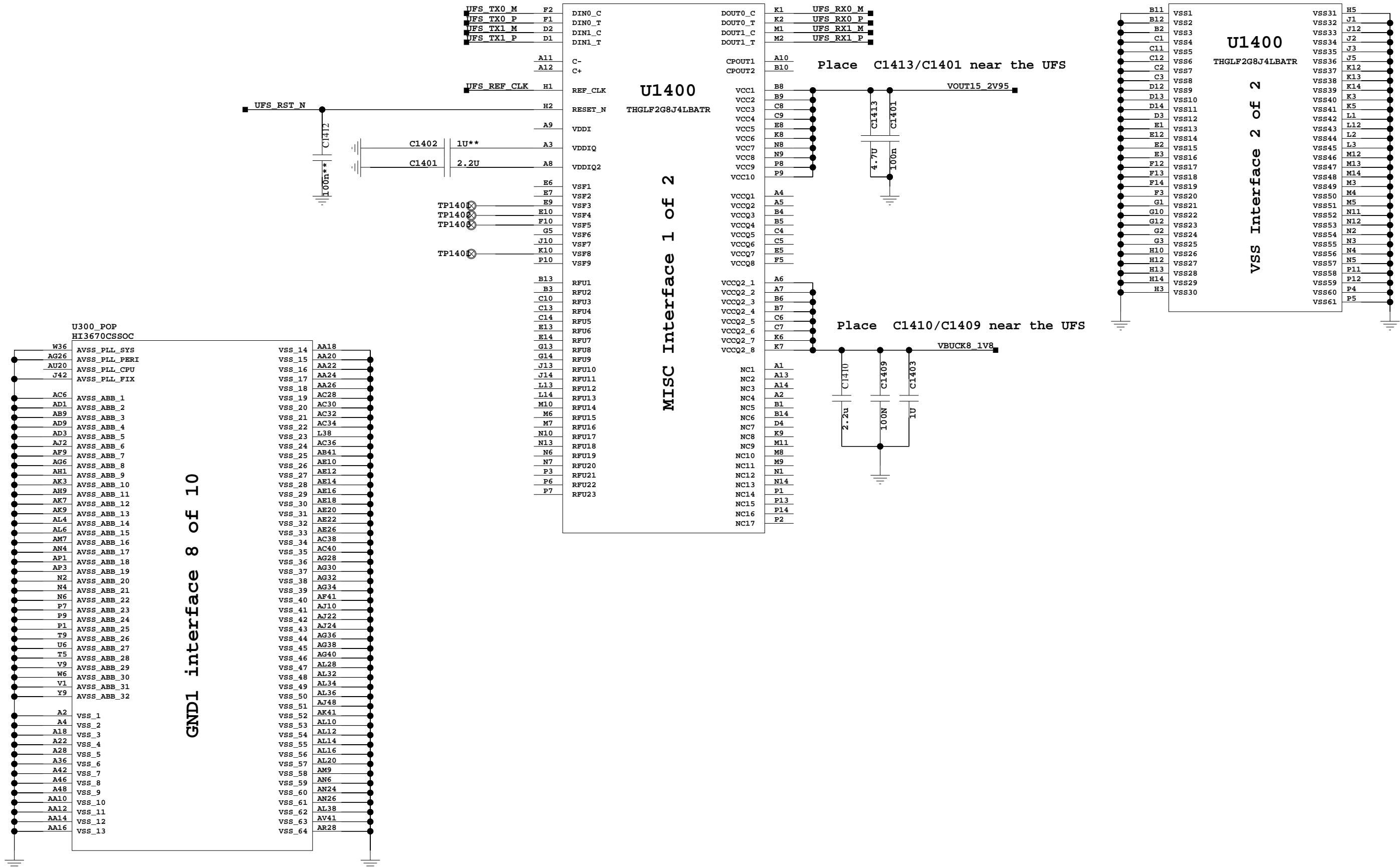

15. Battery & Fuel guage

3777

CAD note:
 1.Trace for 9A
 2.Differential trace

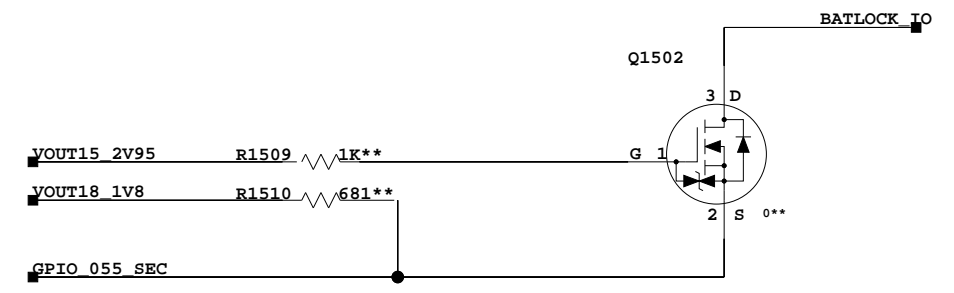
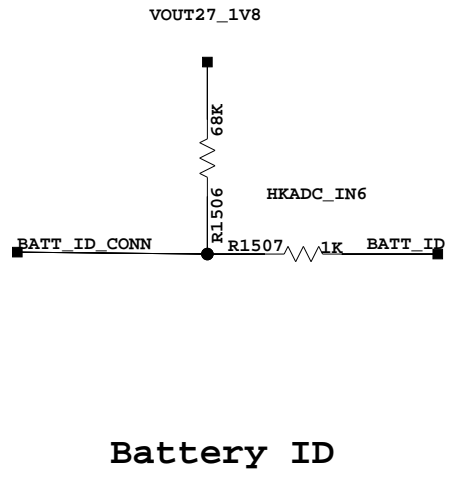
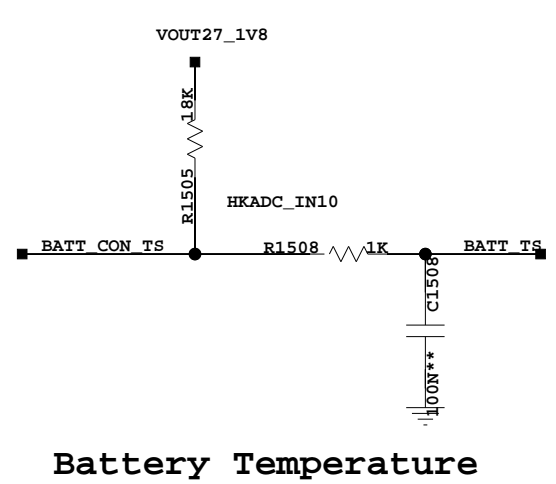
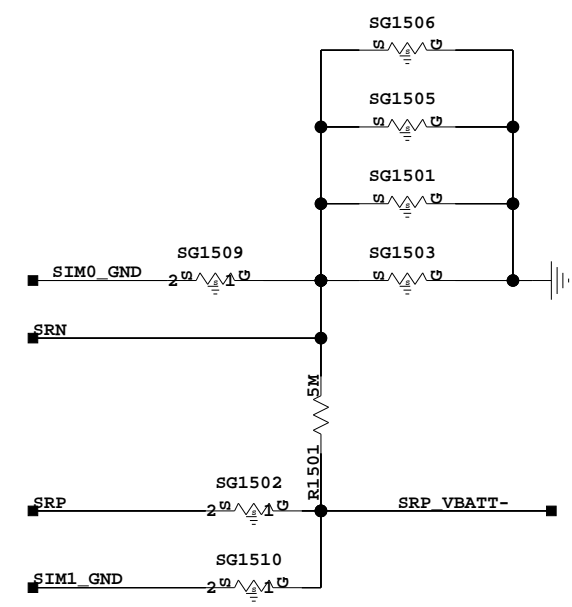
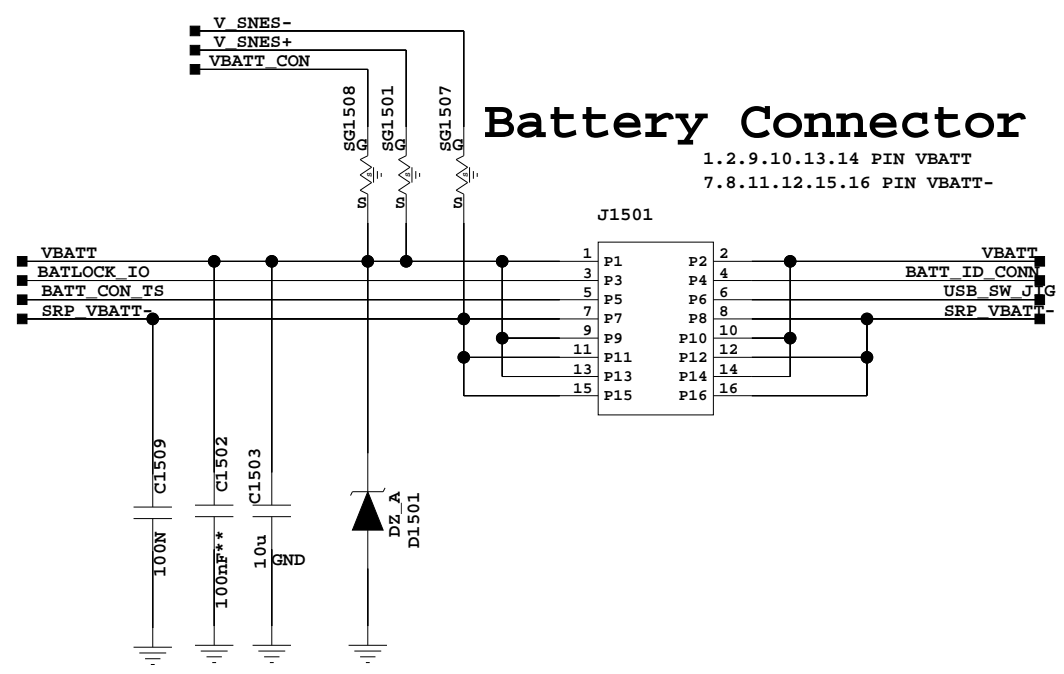

16. Charge Management

アキバ

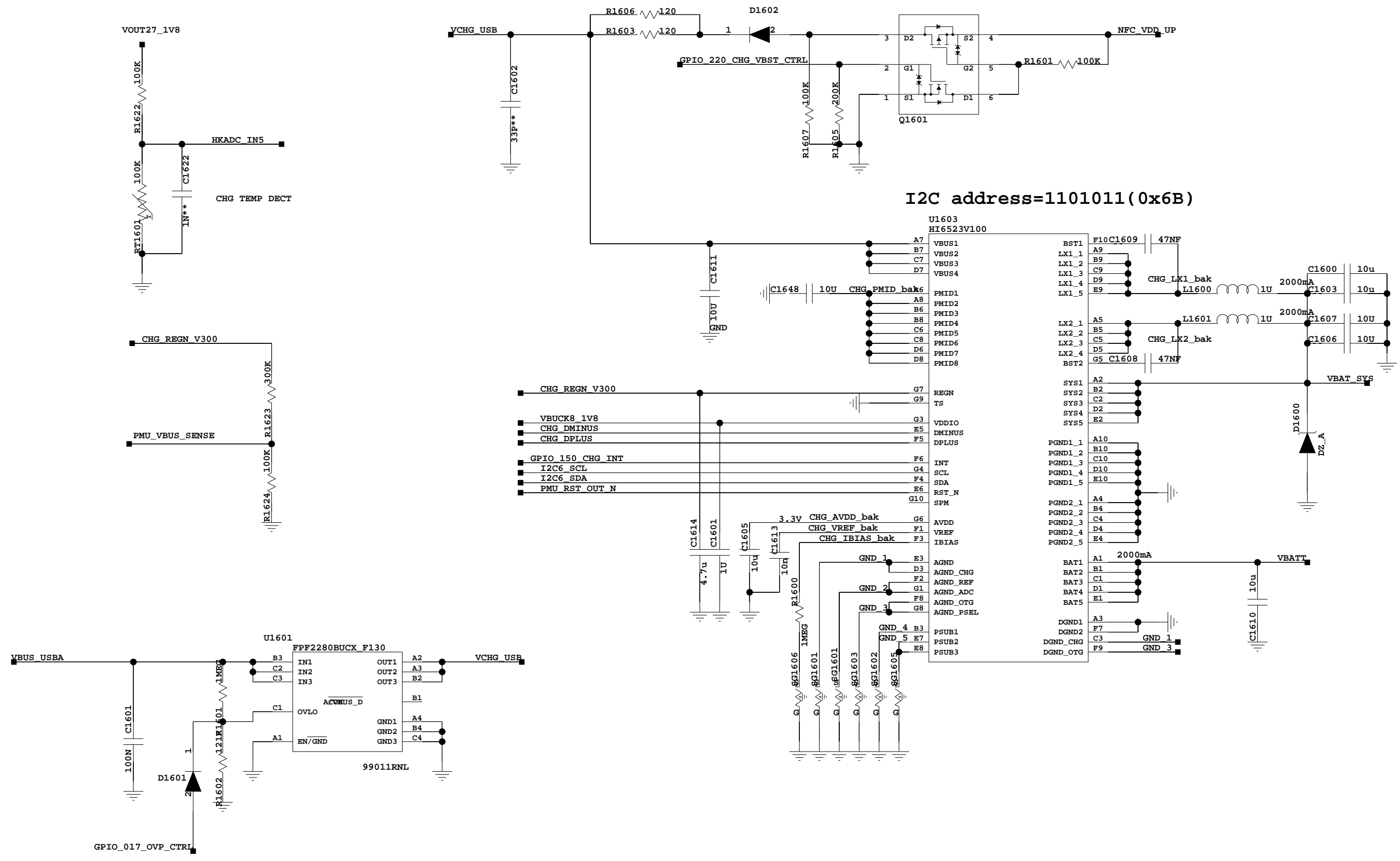

17. LCD Interface

LCD POS/NEG Voltage Driver

CAP tolerance above 50V!!!

I2C address: 0x73 (Richtek) / 0x3E (TI)

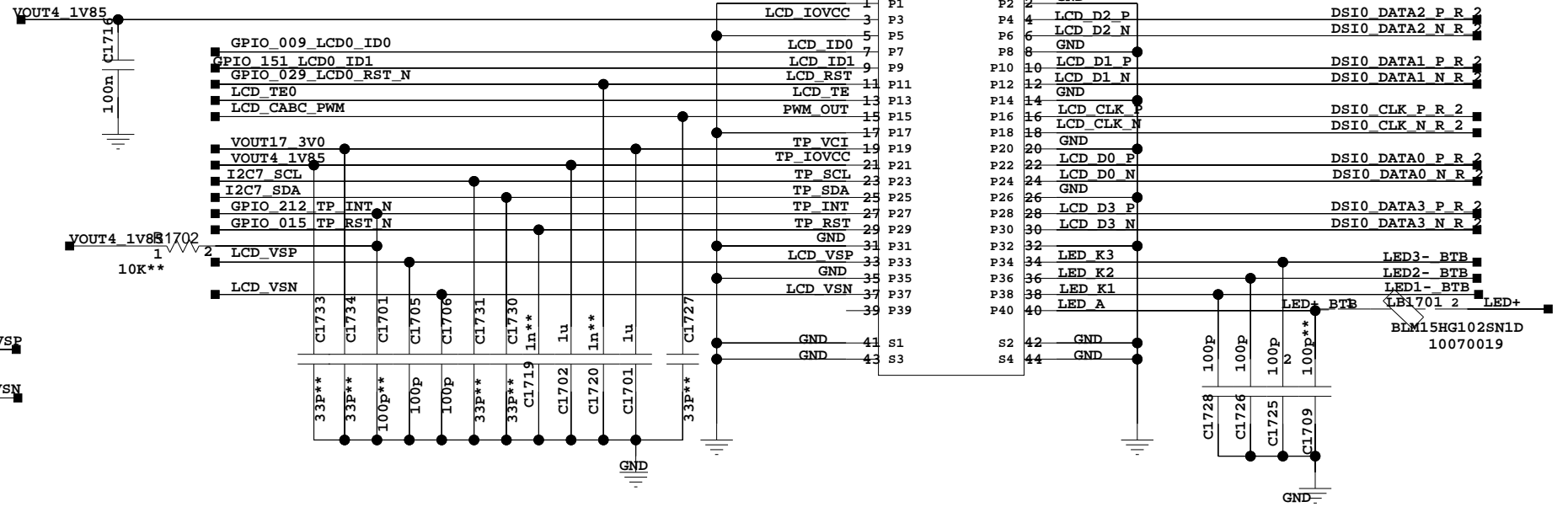
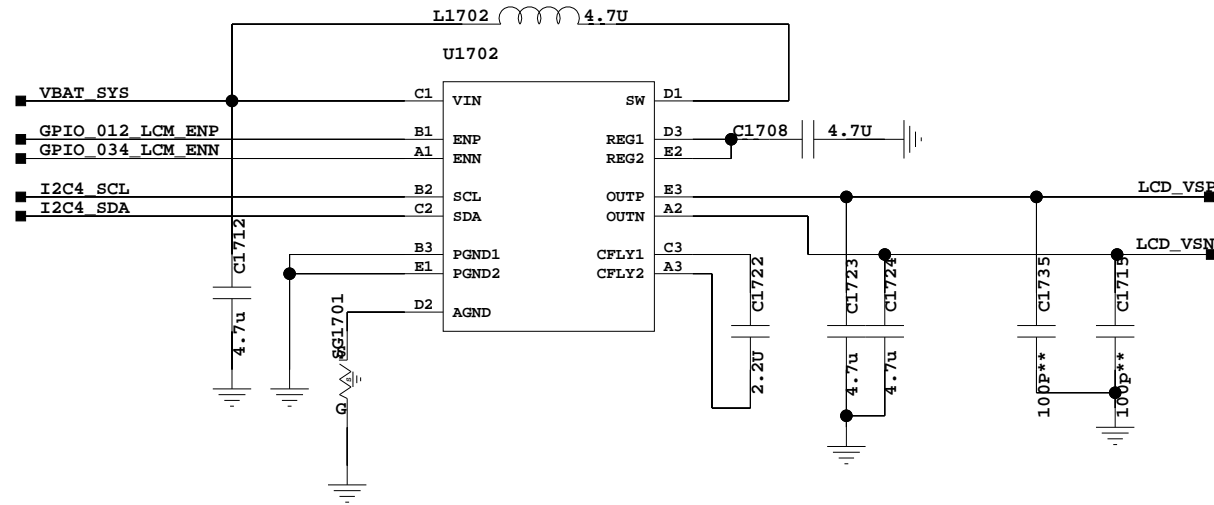

LCD BL DRIVER

CAP tolerance above 50V!!!

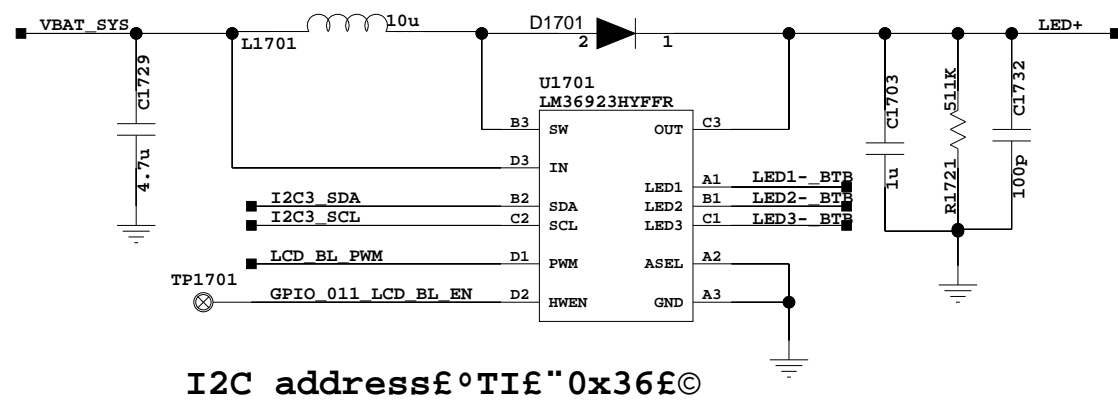

I2C address: 0x36 (TI)

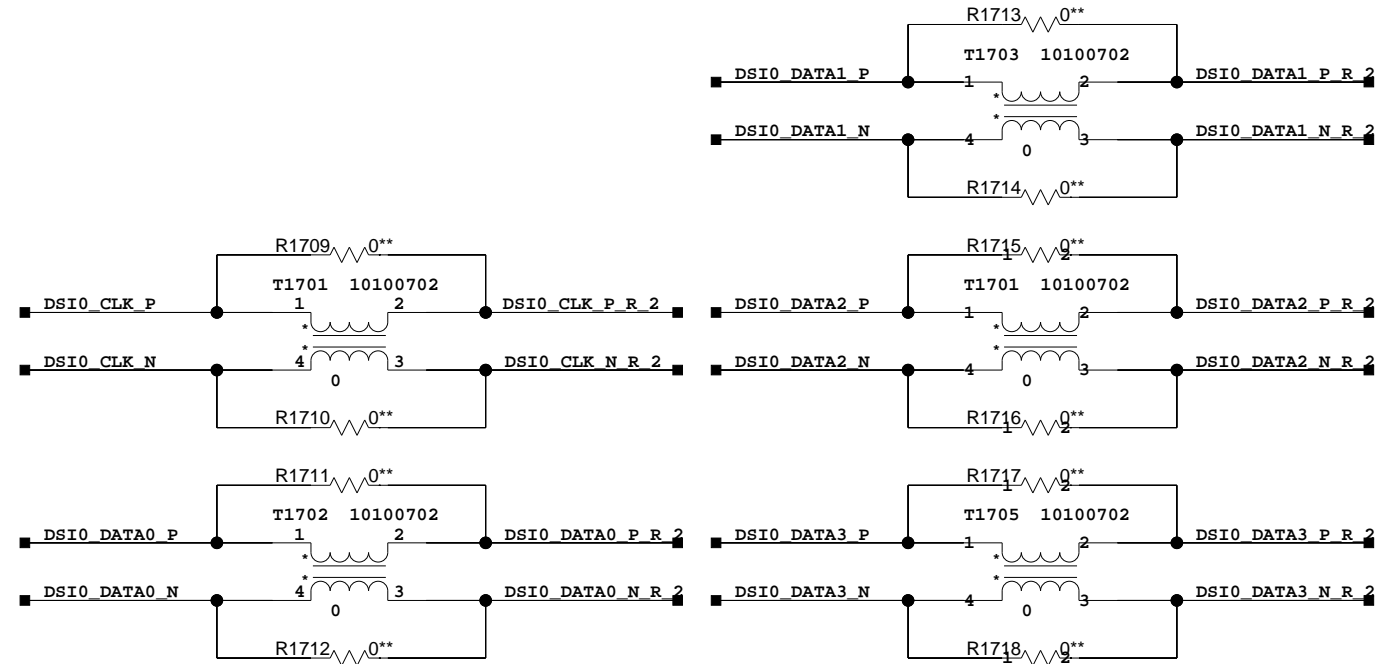

18. Flash/front Camera

^ 1/E/Δ

Flash LED

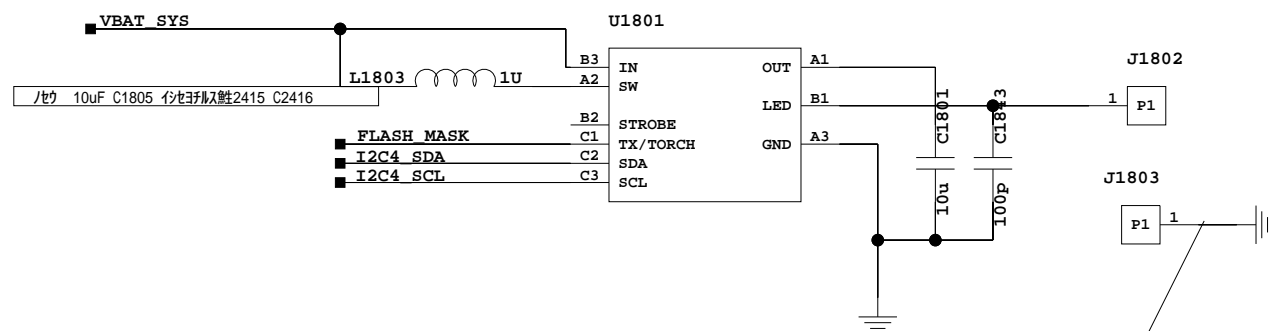

I2C address=1100011(0x63) for TI
I2C address=1100111(0x67) for MPS

24M S-Camera

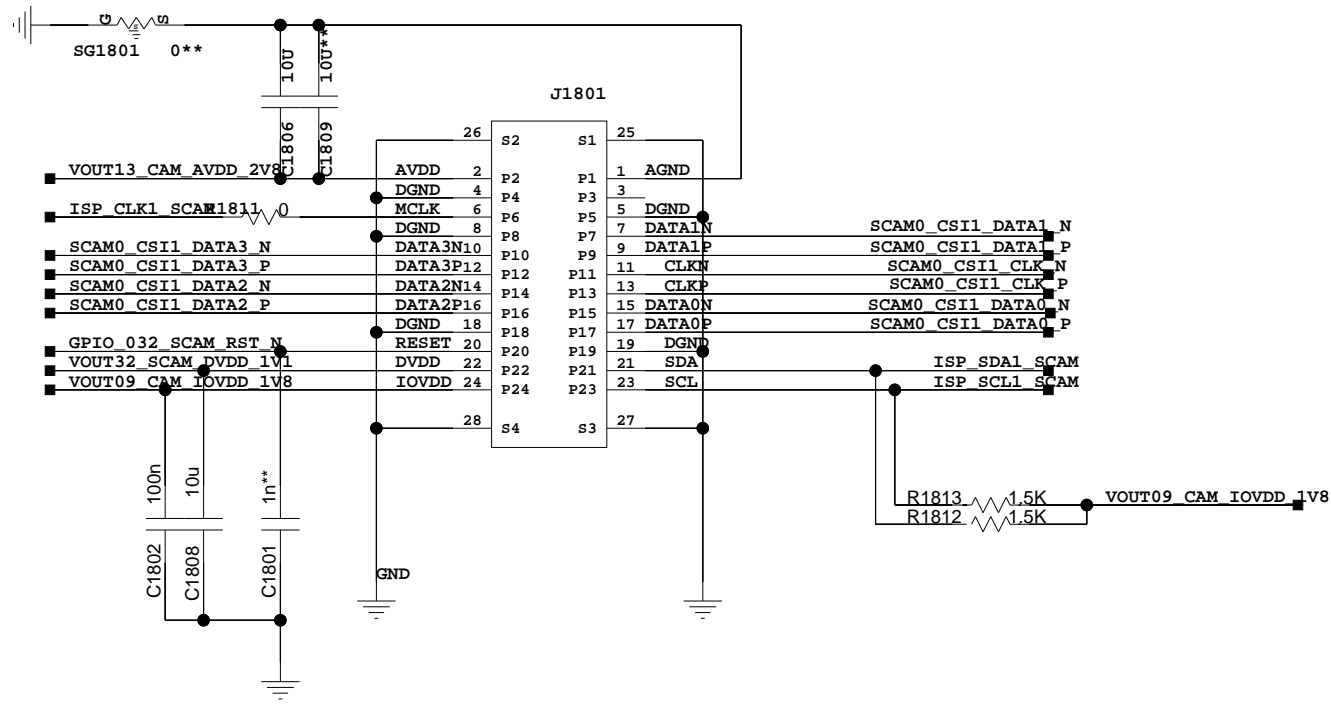

19. M1/M2

^ ルーム

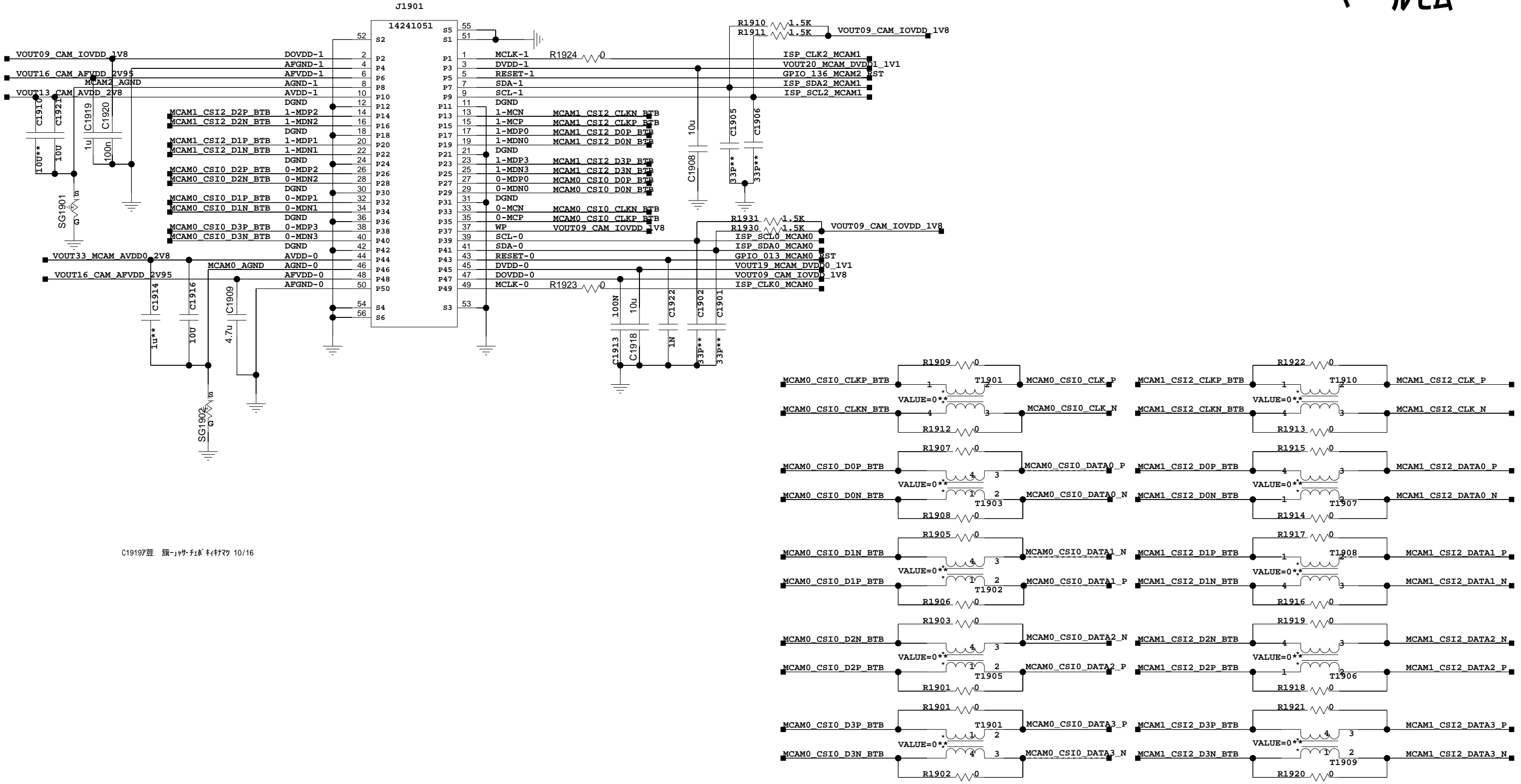

C19197 荳 旗-Jサ・チIホキ付マツ 10/16

20. USB

I2C Address: 0X4E(Richtek) / 0X20(TI) / 0X22(FSC)

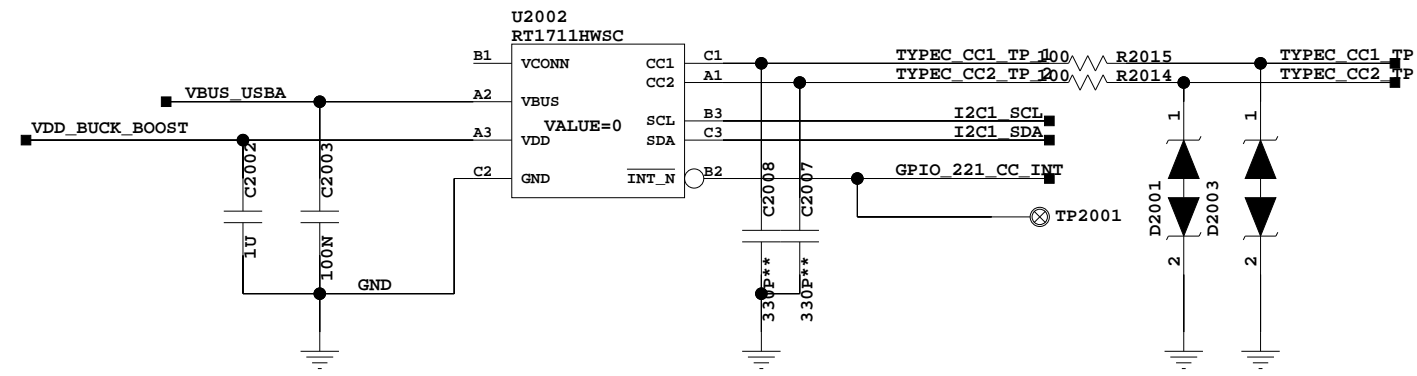
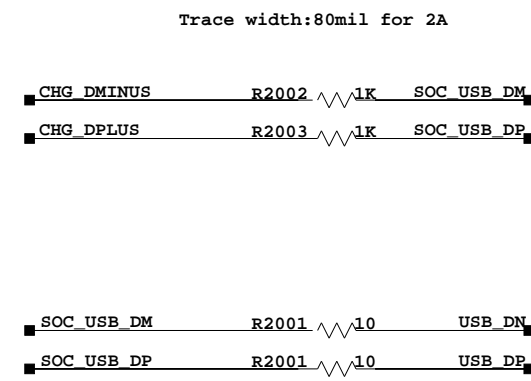

21. Main FPC/Wireless Power

3707A

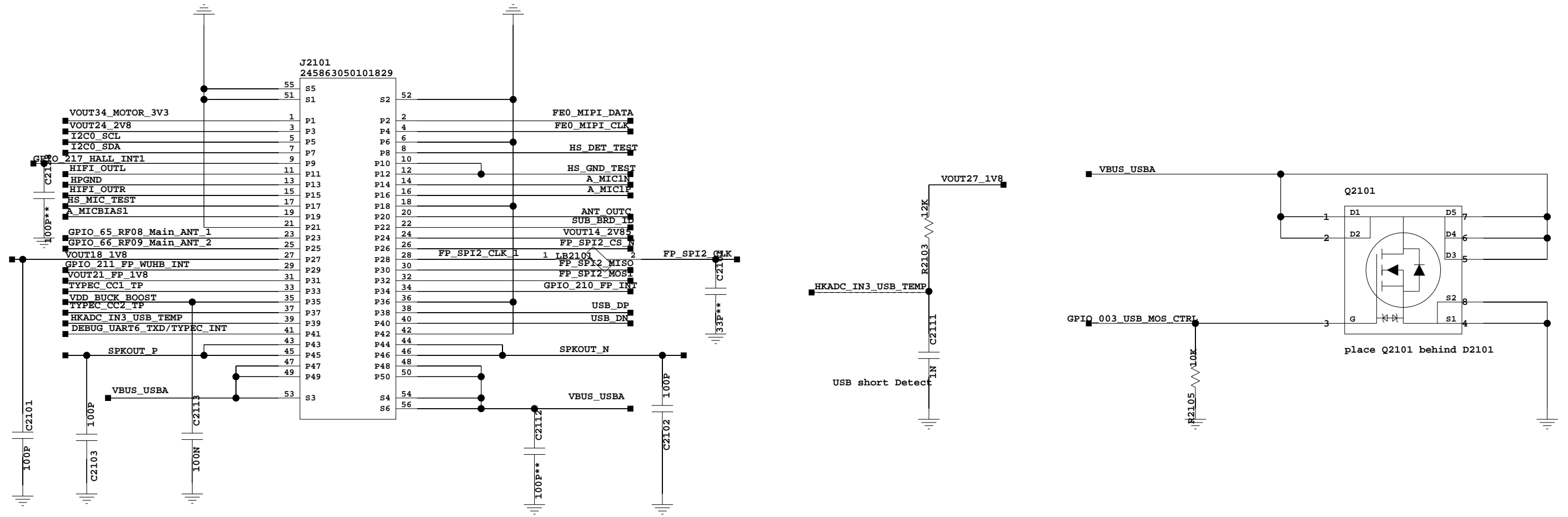

22. CODEC HI6403

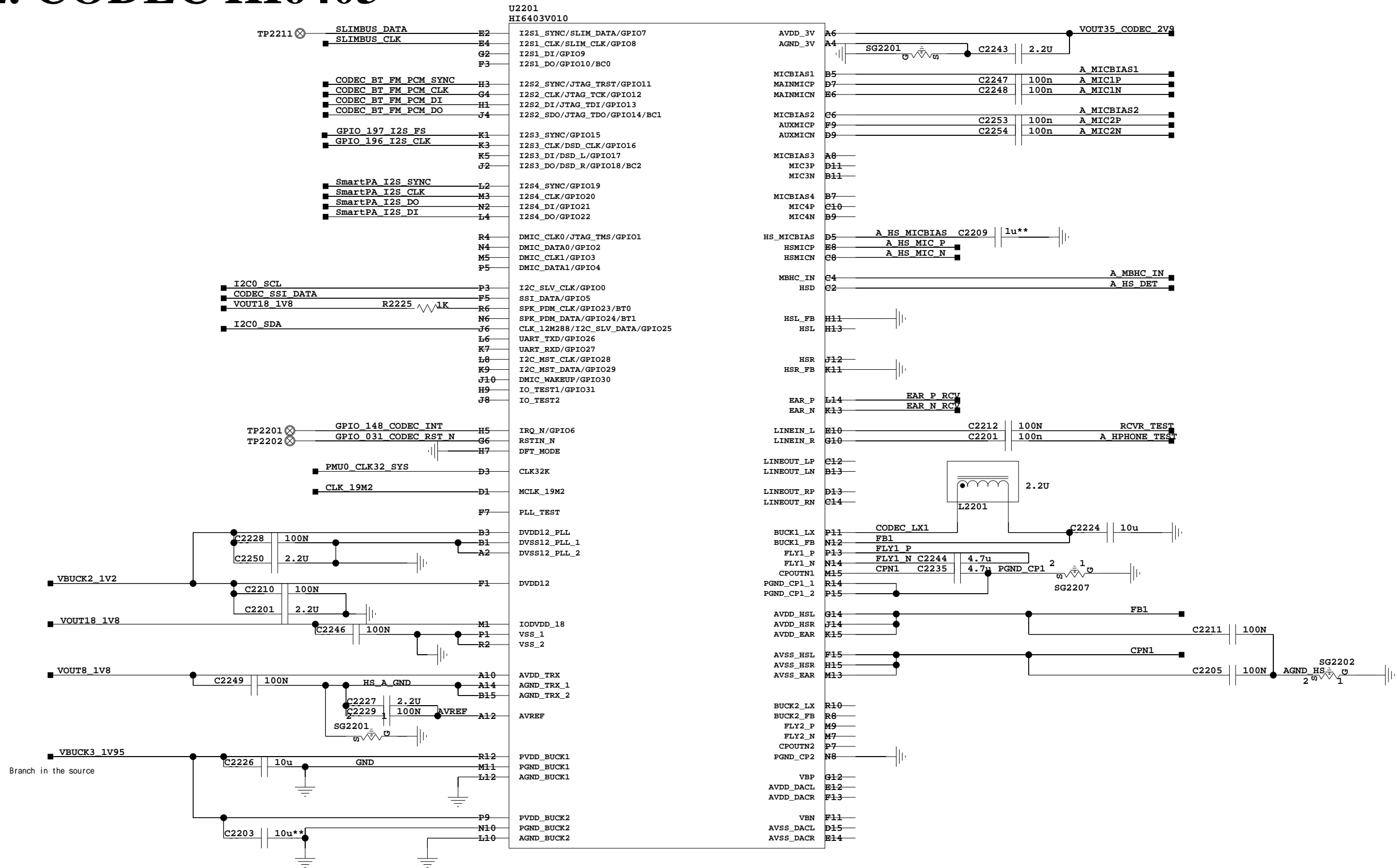

BootMode0	BootMode1	Function(BootROM Start)
1	1	SPI Start
1	0	SSI Start
0	1	I2C Start
0	0	SLIMBUS Start

23. SC Charge

30707

I2C Address=1100111(0x67)

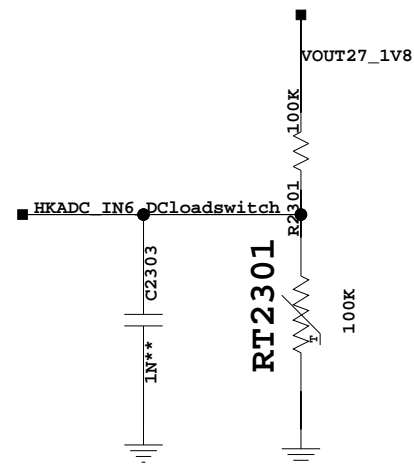
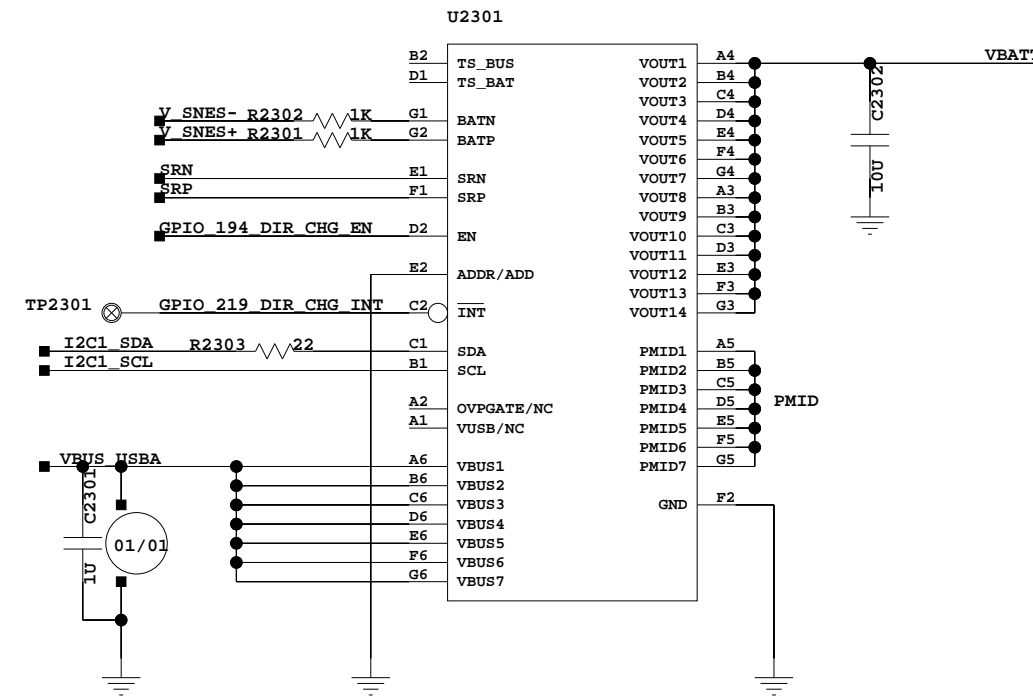

24. SPK SMART PA

けが場

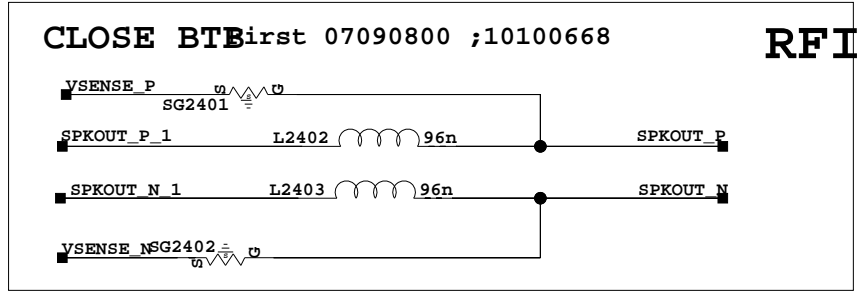
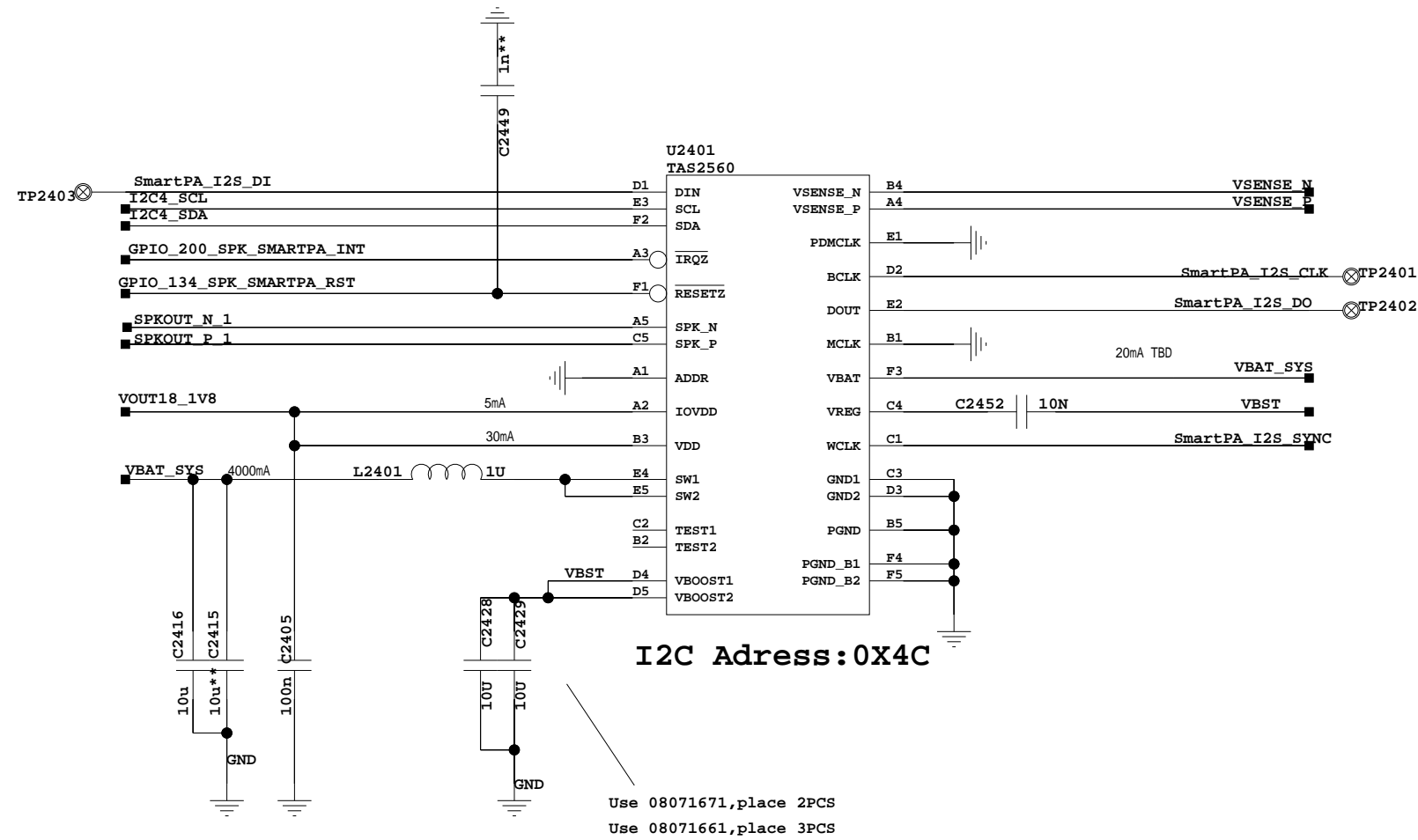

25. MIC/REC/HAC/HIFI

カフ揚

RCV

μC, D, S, P, E, ±, A, A, E, E, °, 10100668f-First bom use 07090800

ホハ-メ icア絞 2050170

I:3 翹絞 110100947, J:1 15BOM E:4 740# J:307090800

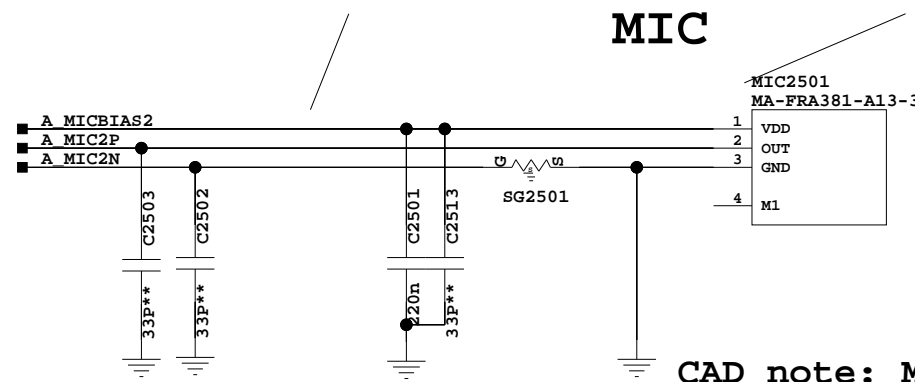

CAD note: MIC need differential trace

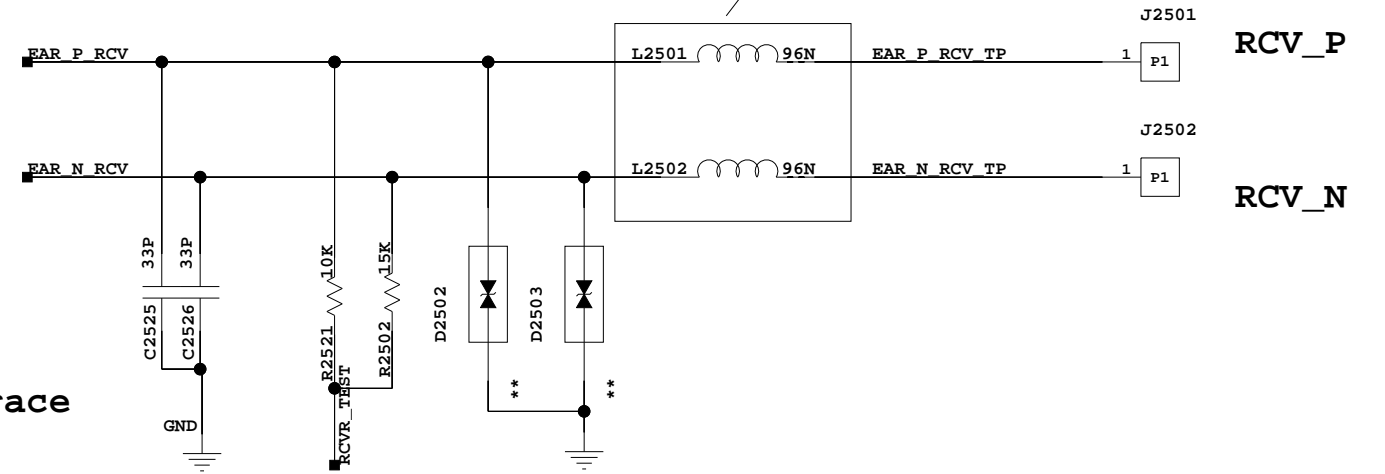

HIFI

U2501 ADDR LOW2C address=0010000

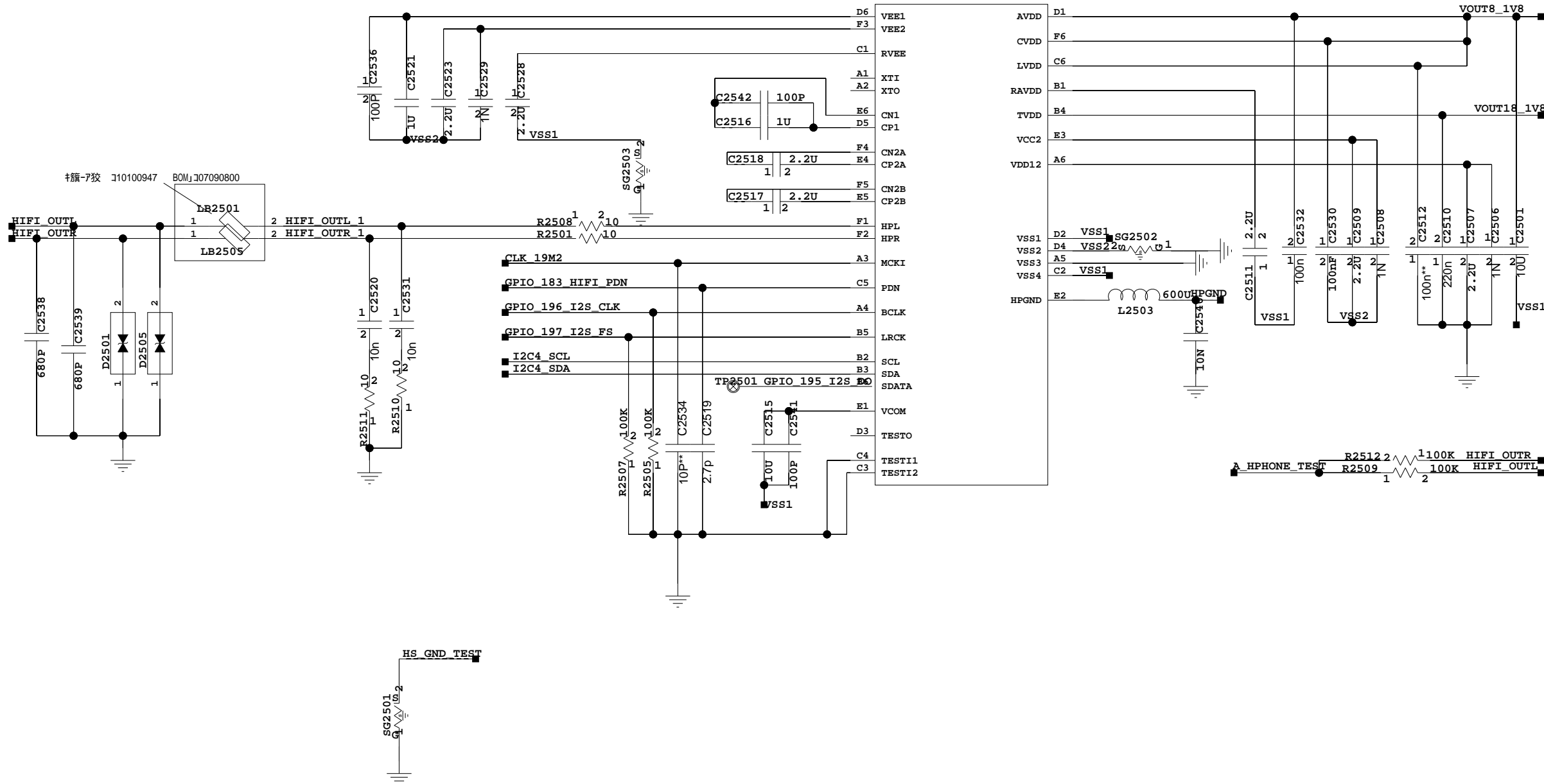

26. Headphone

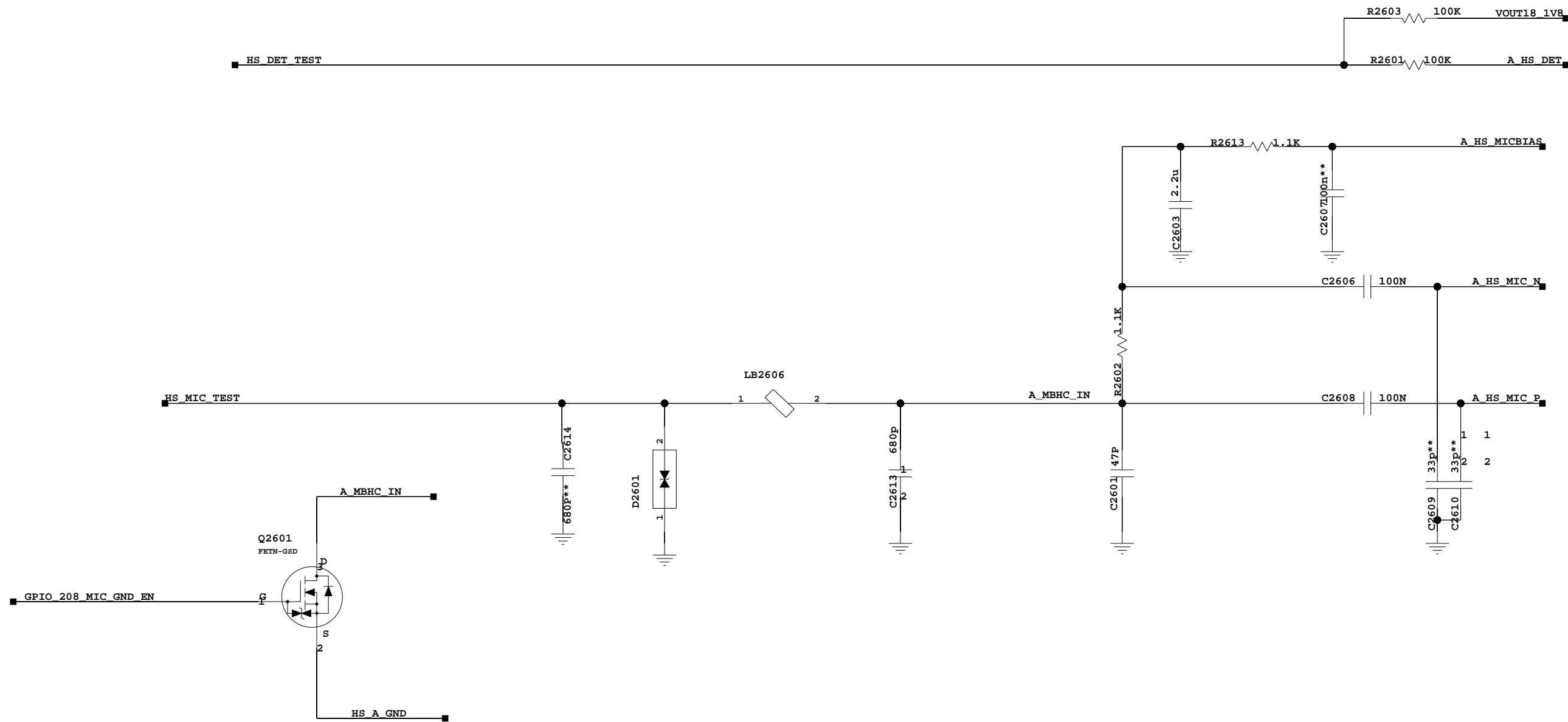
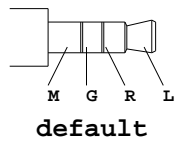

27. X-Sensor

Accelerometer and Gyroscope 6-AXIS SENSOR

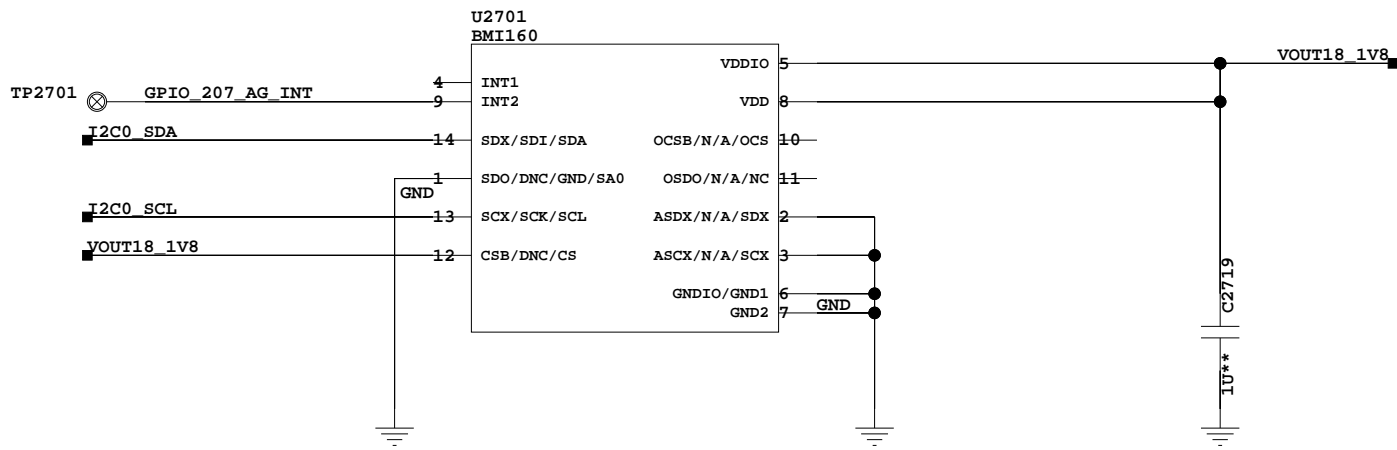

SDO=1 ADDRESS=0X6B(ST)/0X69(BOSCH)
 SDO=0 ADDRESS=0X6A(ST)/0X68(BOSCH)

PROXIMITY&RGB AMBIENT

PROX ADDRESS=0X1E AMB ADDRESS=0X38

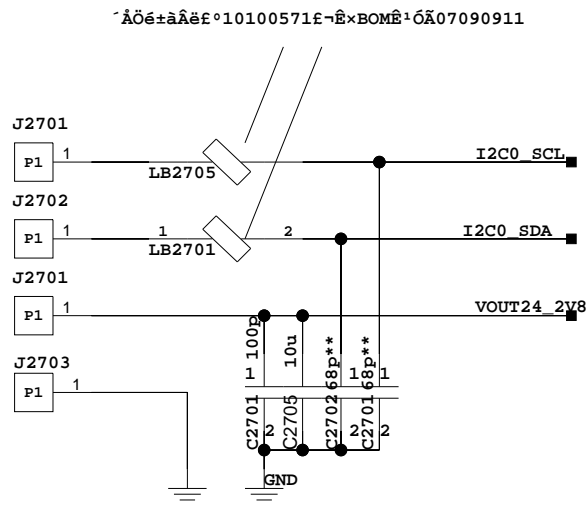

IR

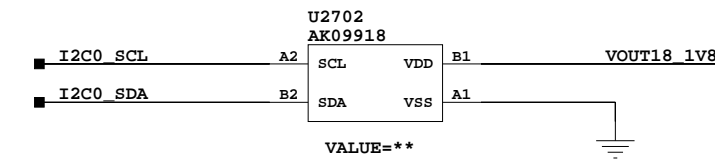
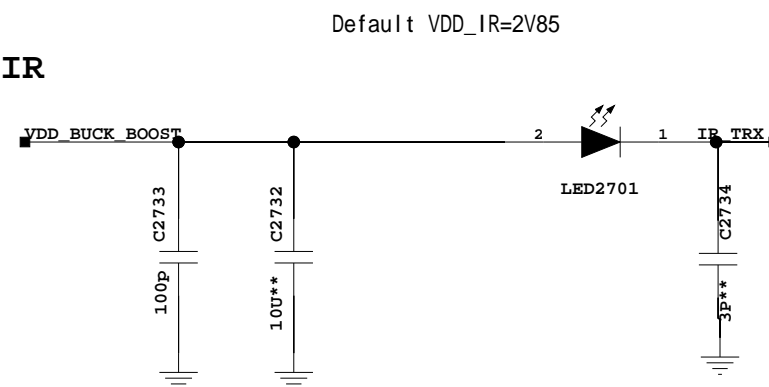

Compass

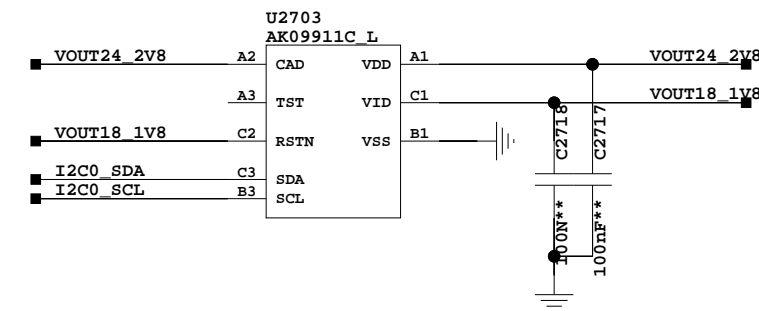

ADDRESS=0X0D

28.SIM/uSD Card

※ 「ネ」

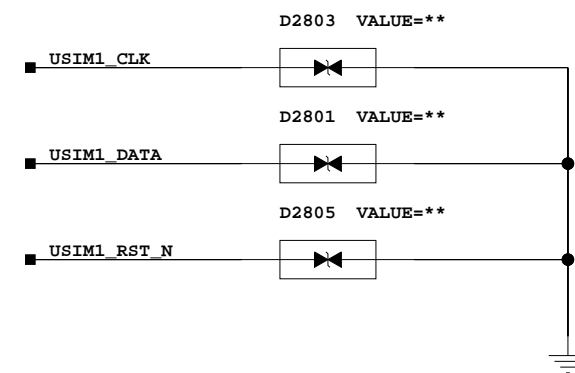
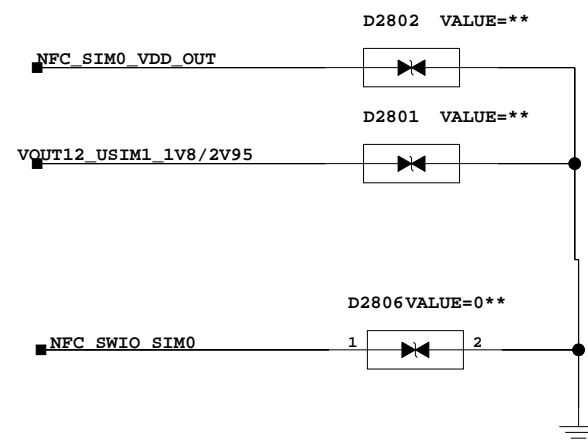
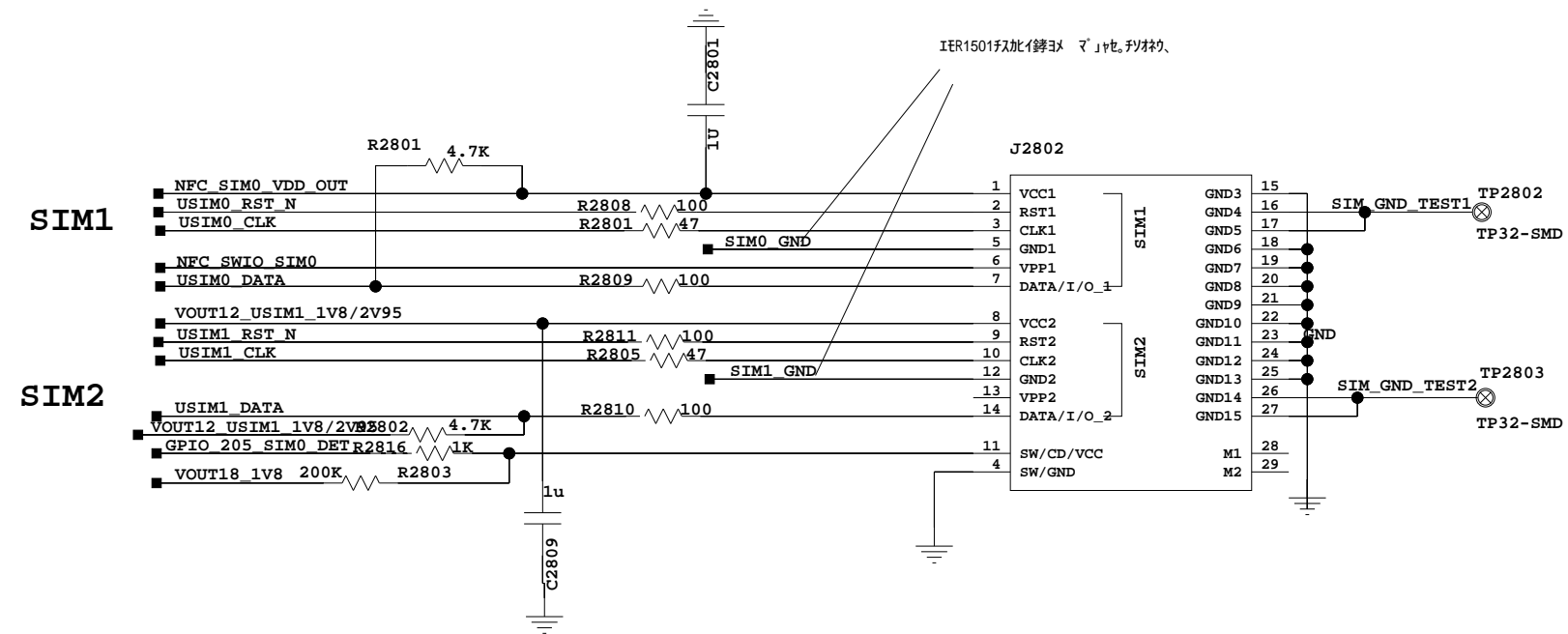

	SIM1_VCC	SE_VCC	VOUT12_2V95
H			○
L		○	

29. LED/FP/Key

KEY SPRING

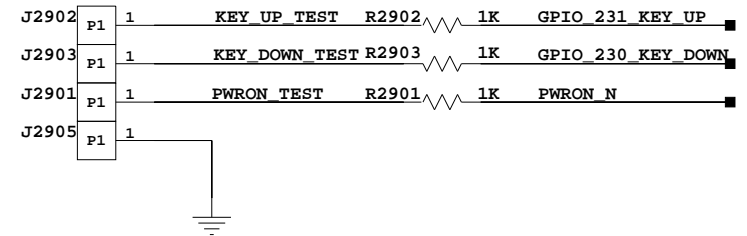

RGB LED

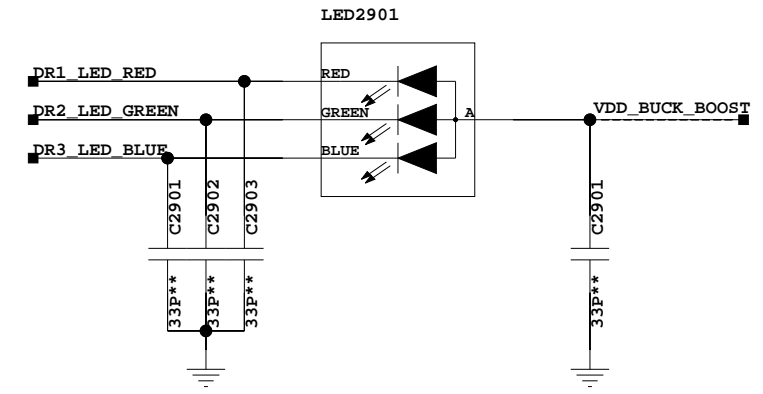

30. Test Points/Shields

※ 「ネ」

VBUS/VBATT/D+/D-/USB_SW_JIG_TEST/:2*TP50

TEST POINT for CT and BT

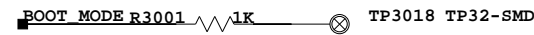
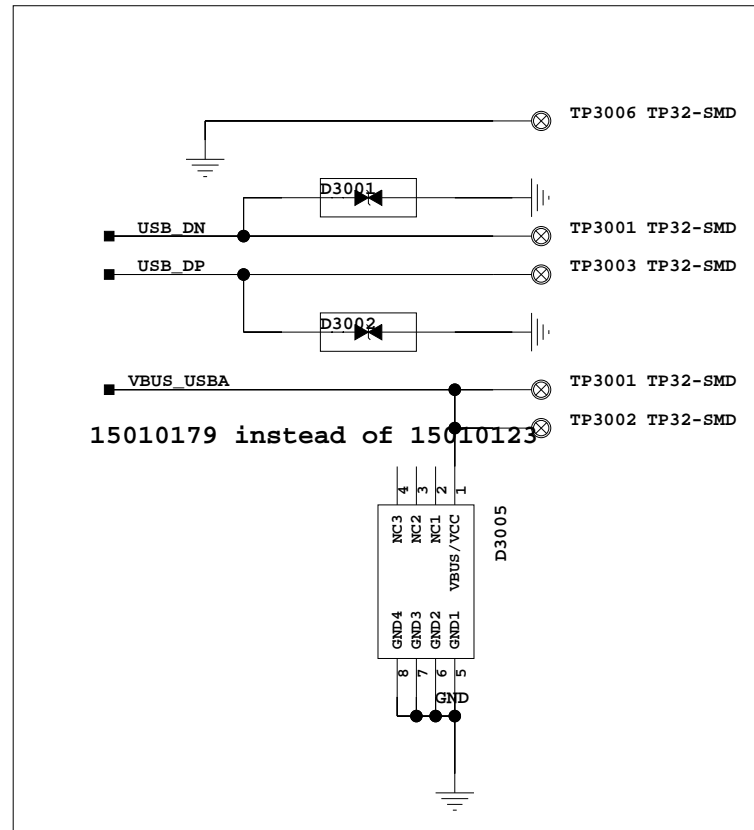

TEST POINT for PT

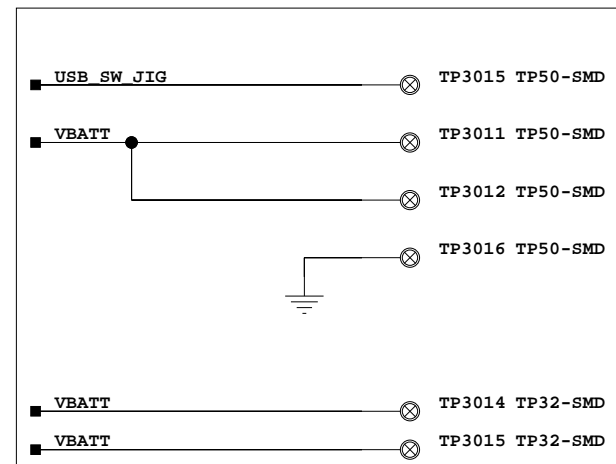

Headphone

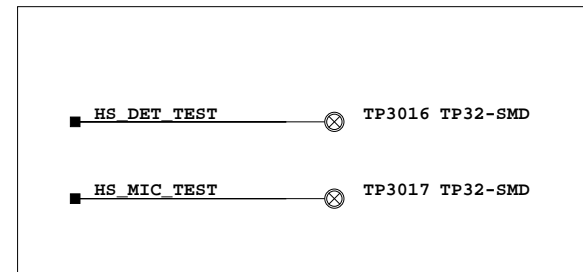

FUNCTION TEST

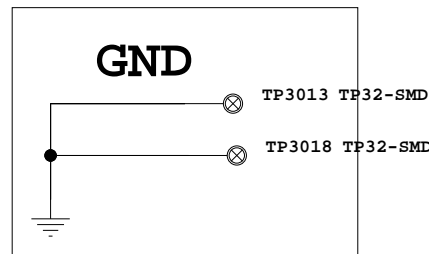

KEY

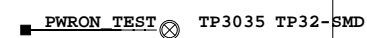

Hole

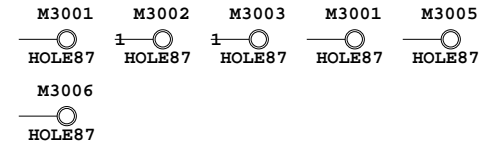

MARK POINT



Tunner

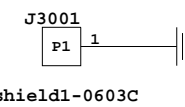

Charger

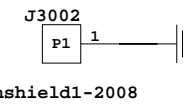

RF

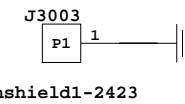

PMU

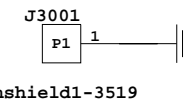

SOC

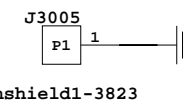

MIC

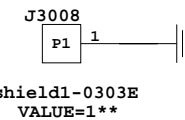

2 1 Ç¿

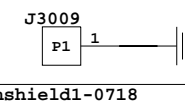

ニチアホリ

CAMメモリオツニヤ

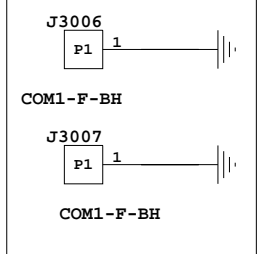

31.RF Interface

RFIC IQ

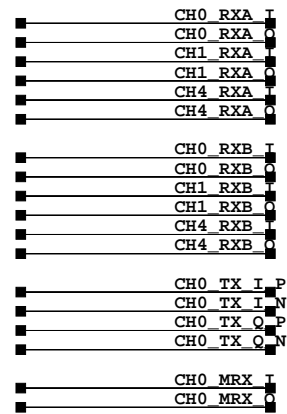

POWER

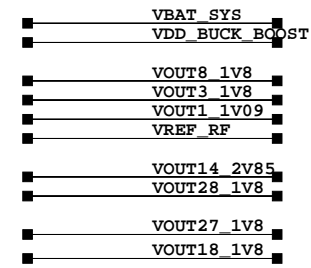

GSM

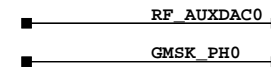

CLK

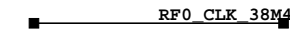

HKADC

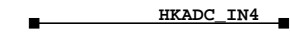

MIPI Interface

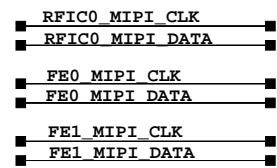

GPIO Interface

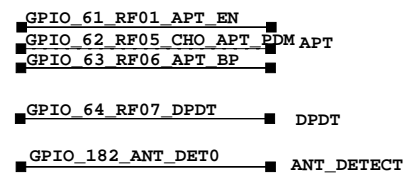

ANT Interface

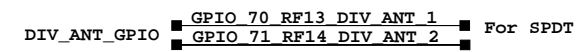
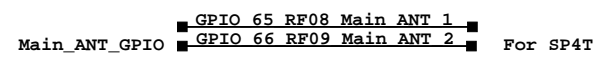

32 APT_LM3243

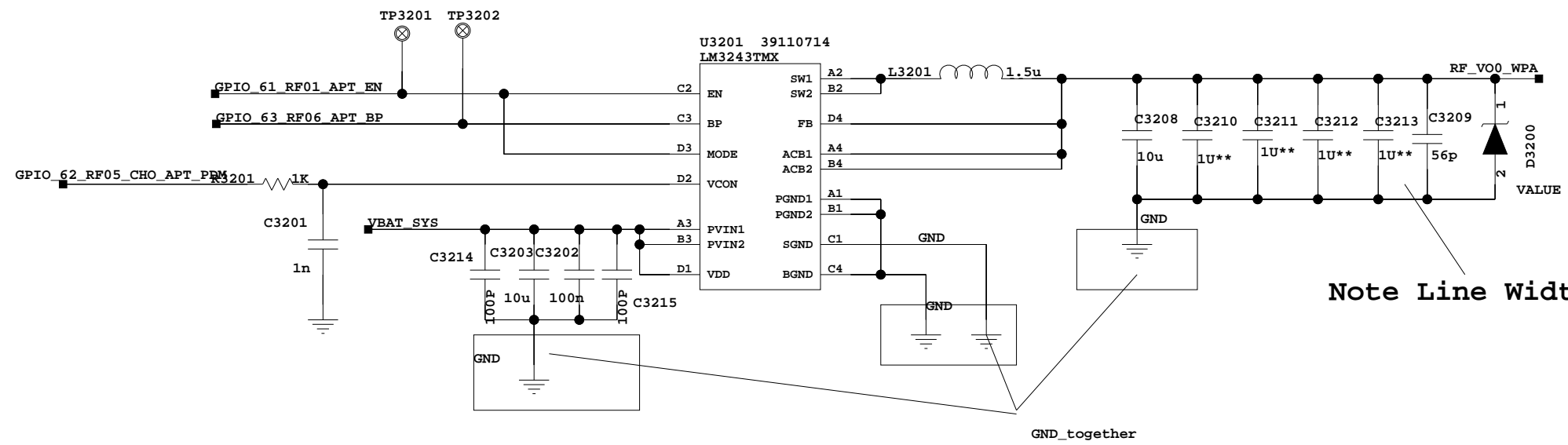

33.RFIC0_Hi6363

DRX LB1 B5&B8&B20 LNA OBT5	RXB_LB1	RX_1A_I	A4	CH0_RXA_I
DRX LB2 Listening LNA OBT4	RXB_LB2	RX_1A_Q	B5	CH0_RXA_Q
DRX HB1 B1&B2&B34 LNA OUT14	RXB_HB1	RX_3A_I	D5	CH1_RXA_I
DRX HB2 B3&B39 LNA OUT5	RXB_HB2	RX_3A_Q	D7	CH1_RXA_Q
DRX HB3 B40 LNA OUT4	RXB_HB3	RX_2A_I	C10	CH4_RXA_I
DRX HB4 B7&B41 LNA OUT5	RXB_HB4	RX_2A_Q	A10	CH4_RXA_Q
DRX HB5 Listening LNA OBT4	RXB_HB5			
	M15			
	K15			
PRX LB1 B5&B8&B20 LNA OUT1	RXA_LB1	RX_1B_I	A6	CH0_RXB_I
PRX LB2 Listening LNA OUT2	RXA_LB2	RX_1B_Q	C6	CH0_RXB_Q
PRX HB1 B1&B2&B34 LNA OUTJ2	RXA_HB1	RX_3B_I	D9	CH1_RXB_I
PRX HB2 B3&B39 LNA OUTH1	RXA_HB2	RX_3B_Q	D11	CH1_RXB_Q
PRX HB3 B40 LNA OUTG2	RXA_HB3	RX_2B_I	B11	CH4_RXB_I
PRX HB4 B7&B41 LNA OUTF1	RXA_HB4	RX_2B_Q	A12	CH4_RXB_Q
PRX HB5 Listening LNA OUE2	RXA_HB5			
	M1			
	K1			
RFIC0_TX1_LB1	TX1_LB1	TX1_I_P	R6	CH0_TX_I_P
RFIC0_TX1_LB2	TX1_LB2	TX1_I_N	T7	CH0_TX_I_N
RFIC0_TX1_HB1	TX1_HB1	TX1_Q_P	N8	CH0_TX_Q_P
RFIC0_TX1_HB2	TX1_HB2	TX1_Q_N	P7	CH0_TX_Q_N
RFIC0_TX1_HB3	TX1_HB3			
	Y9			
	Y13			
	AA4			
	Y3			
	V1			
	N14			

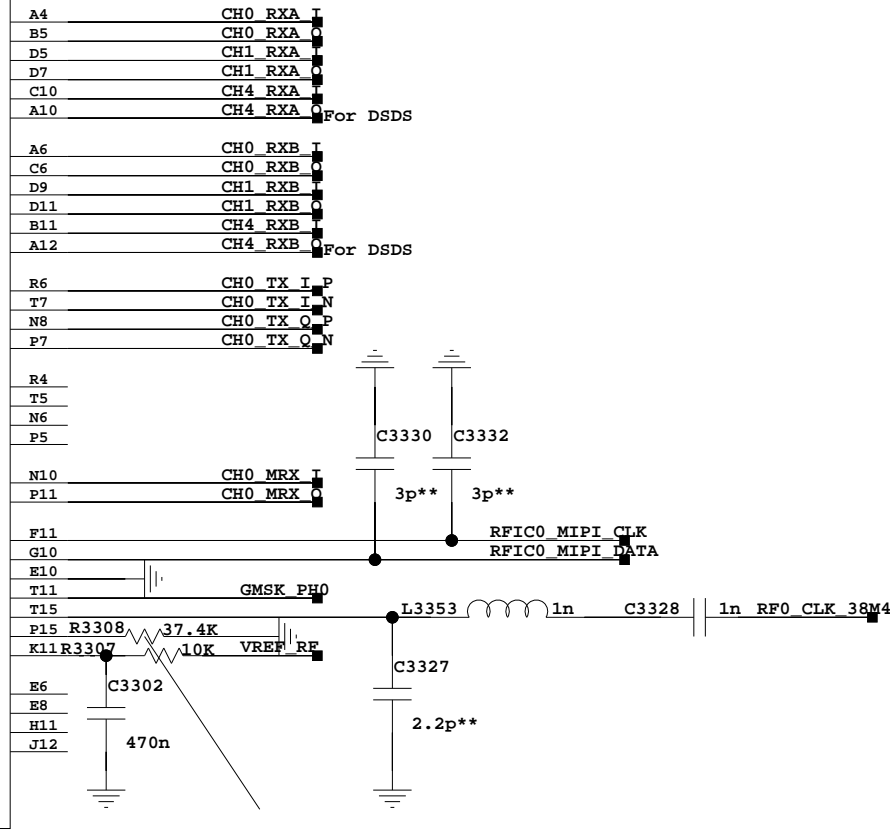
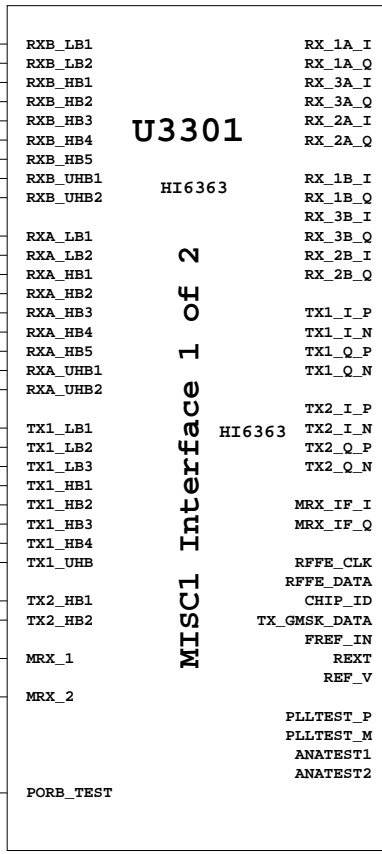

R3308 Need 37.4K , and 1%

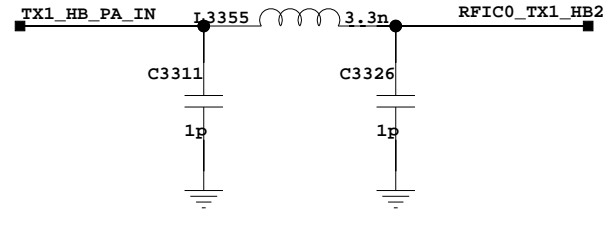
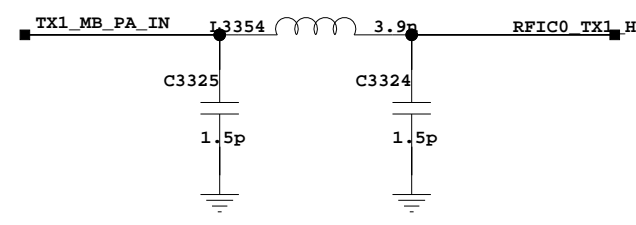
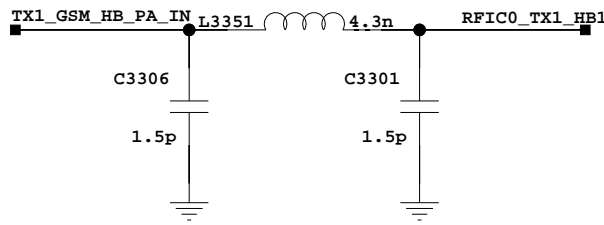
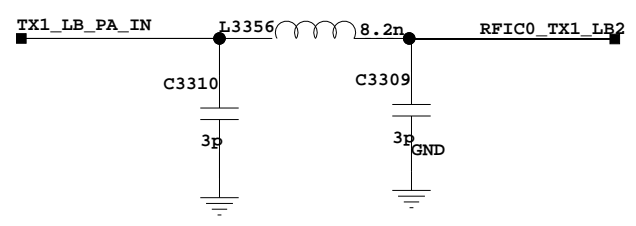
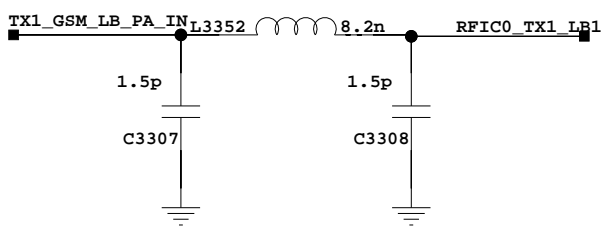
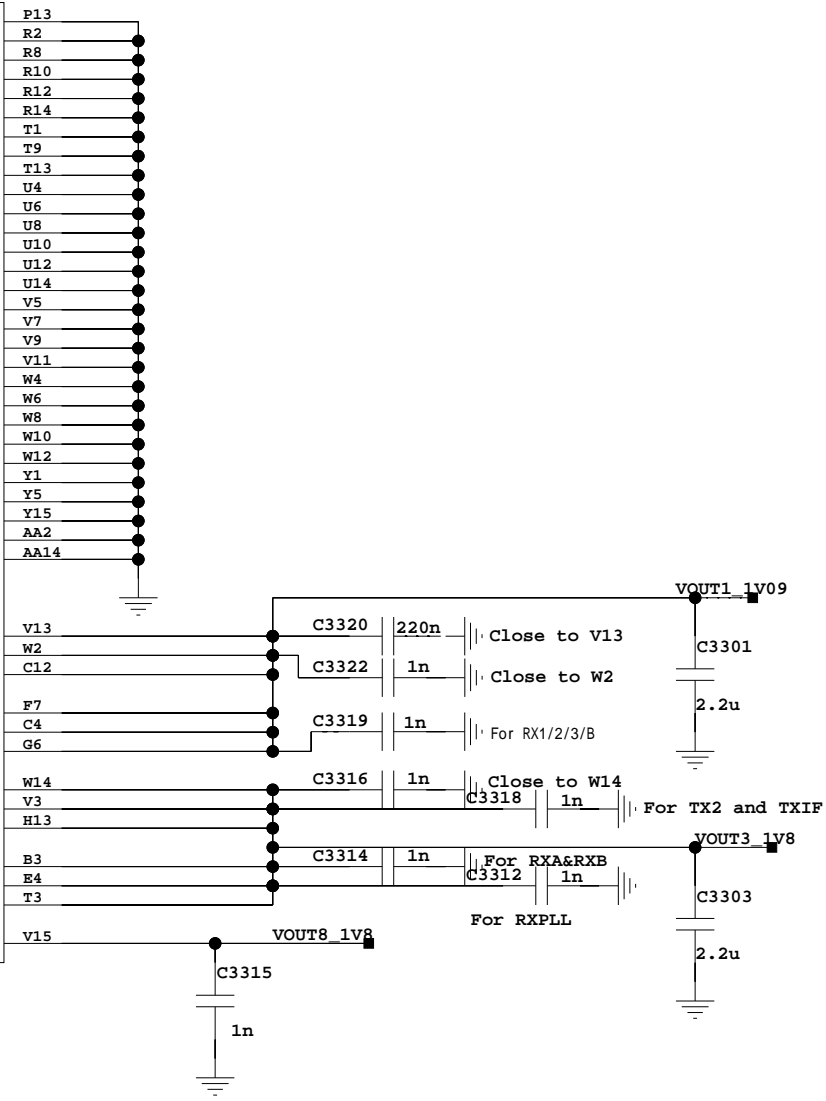
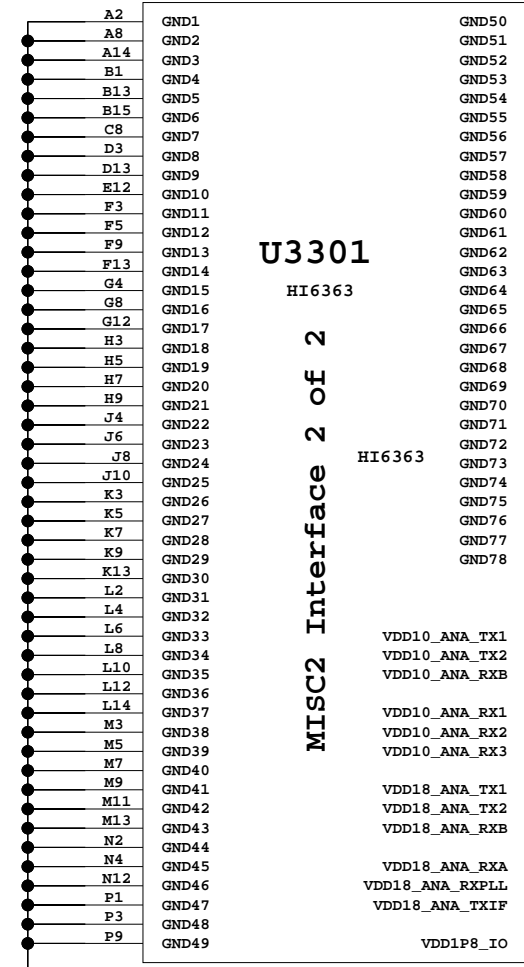

RFIC_TX_OUTPUT_MATCHING

34 DPDT_Connector

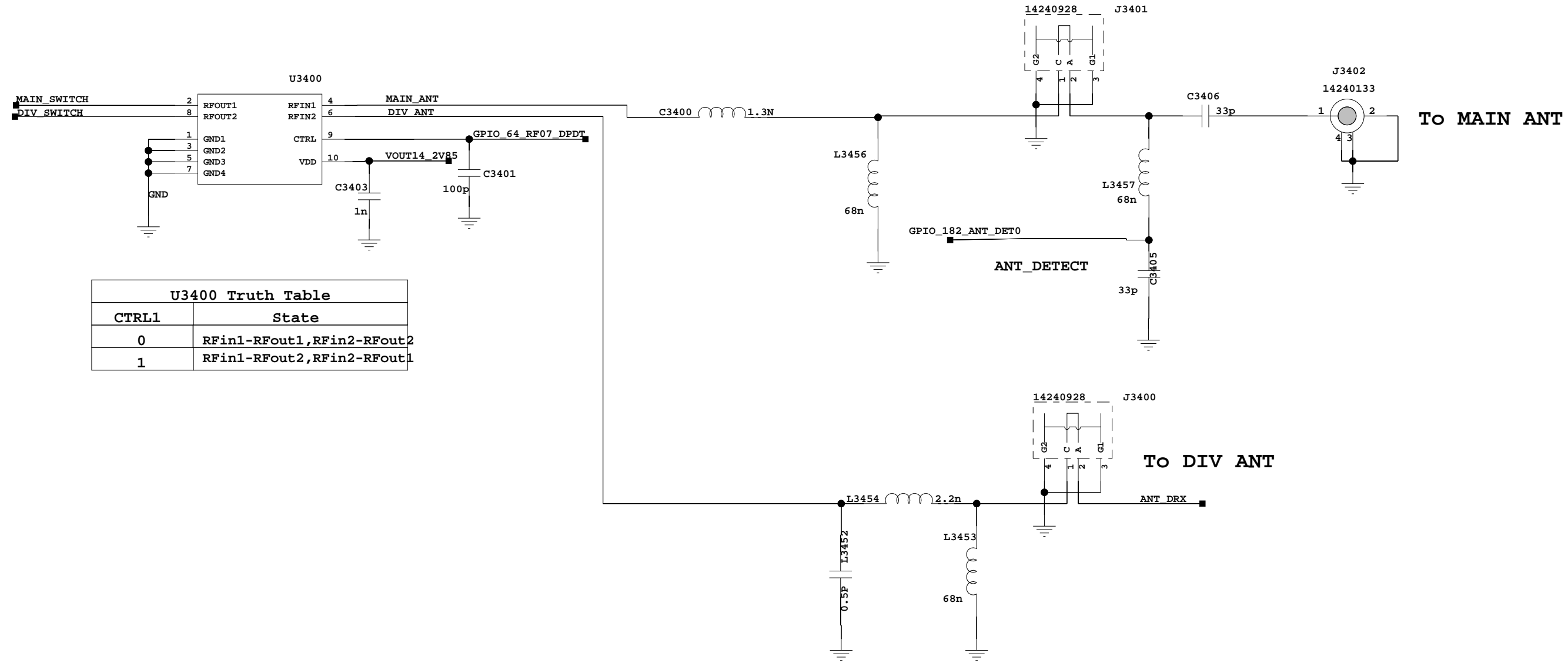

U3400 Truth Table

CTRL1	State
0	RFin1-RFout1,RFin2-RFout2
1	RFin1-RFout2,RFin2-RFout1

35. TXM

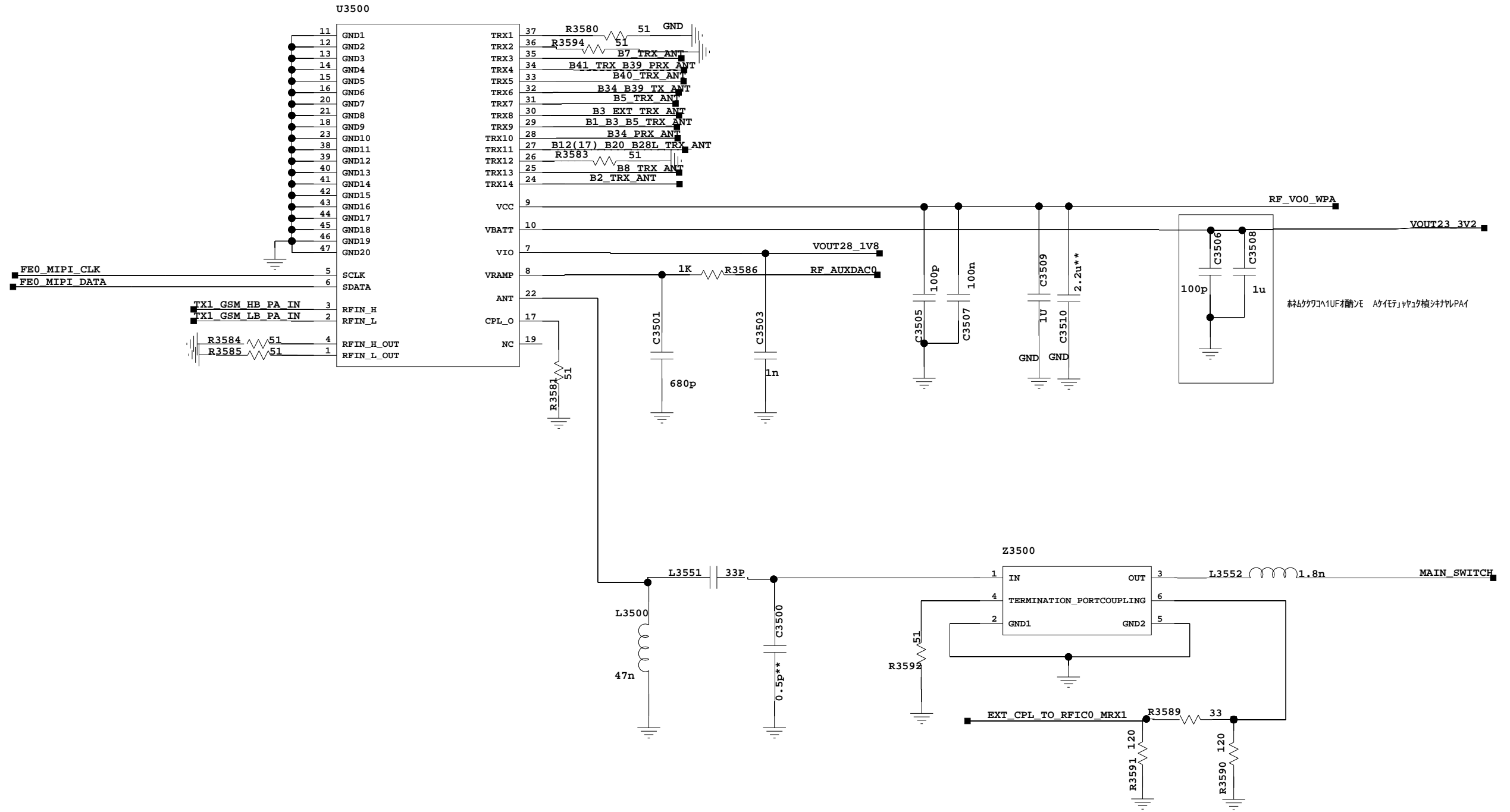

36 MMBPA

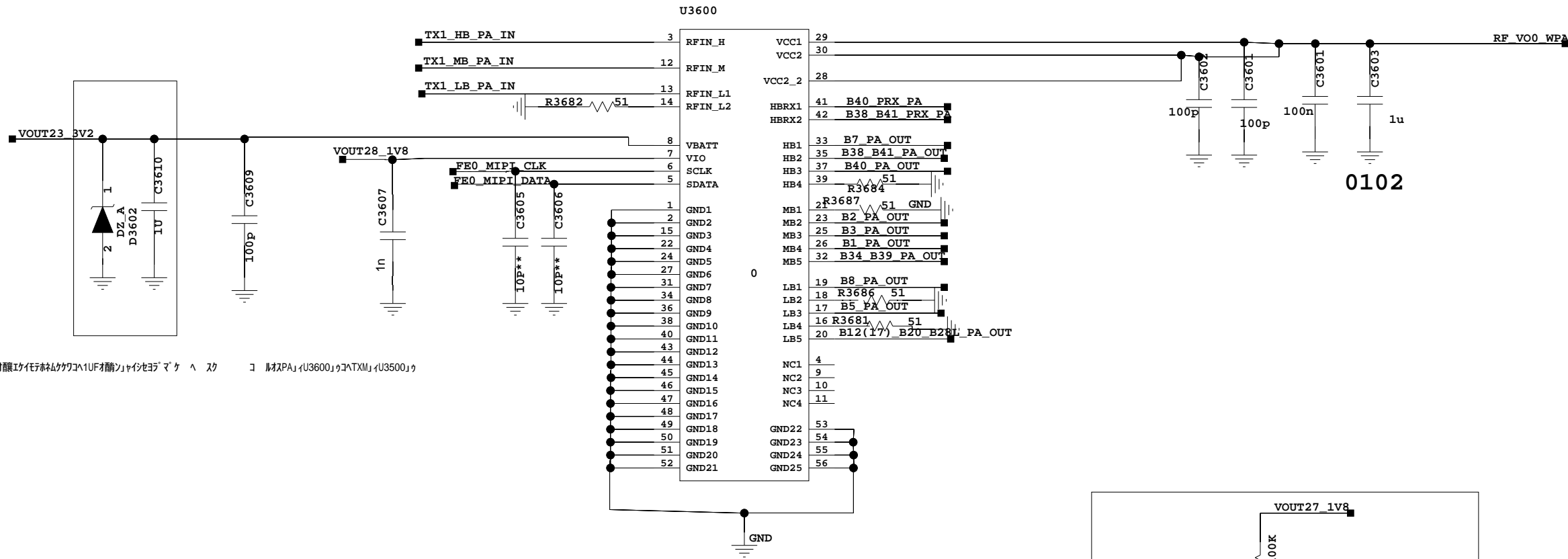

Vccオ醜ケイサウケ 3.4V

LDOオ醜ケイサウケハ1UFオ醜ケイサウケマケ ヲ ス 材PA(U3600)ハTX(U3500)ハ

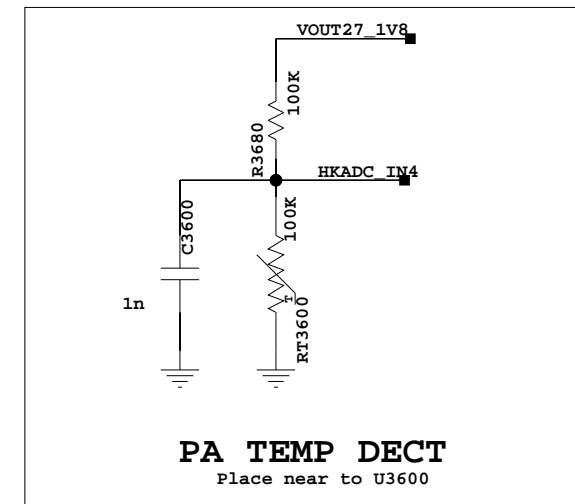

37.TX_Loadpull

LB

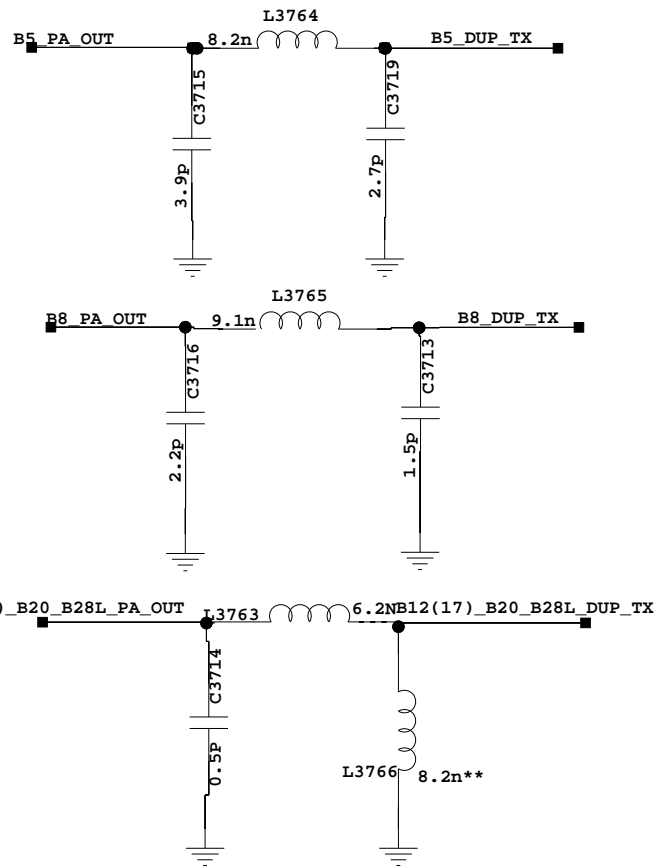

MB

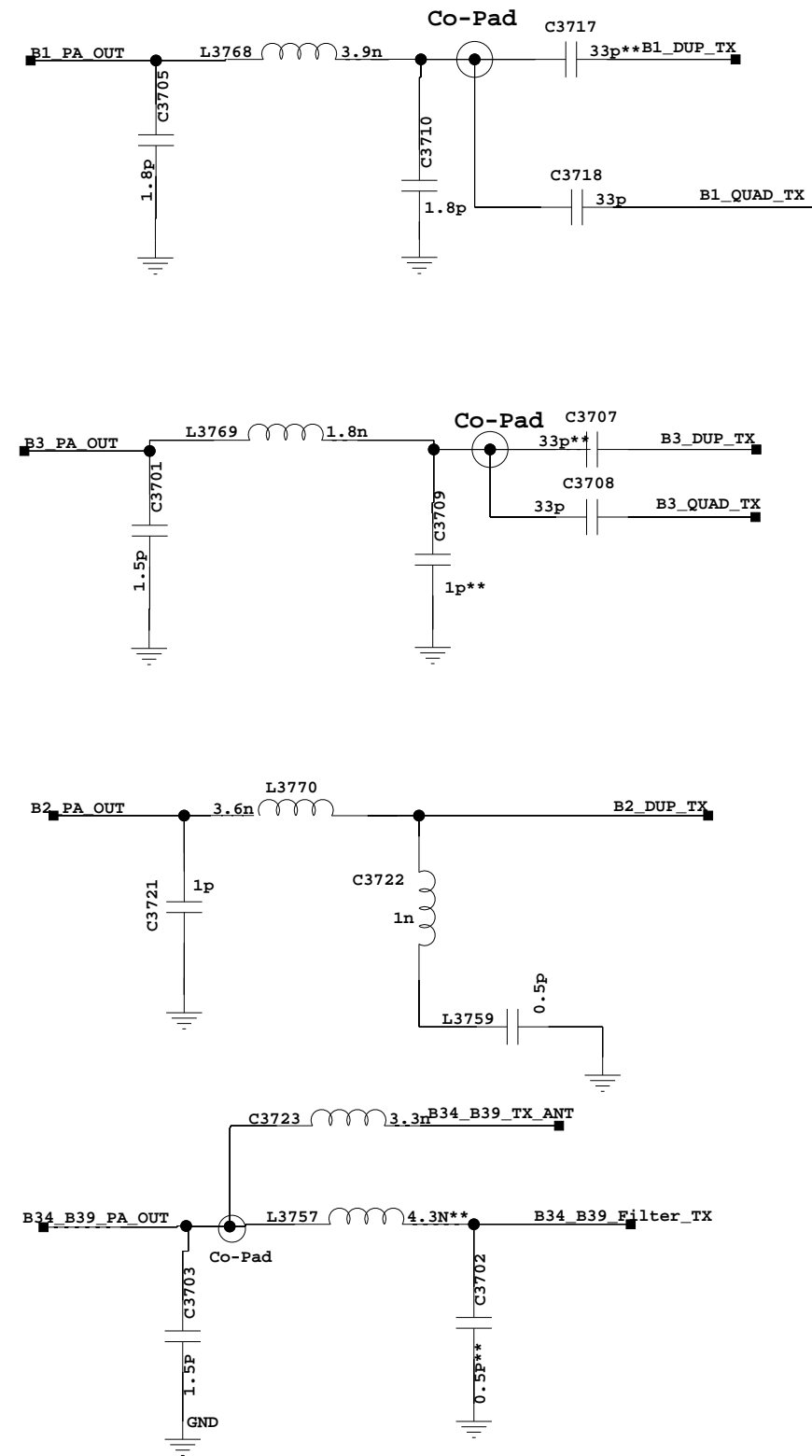

HB

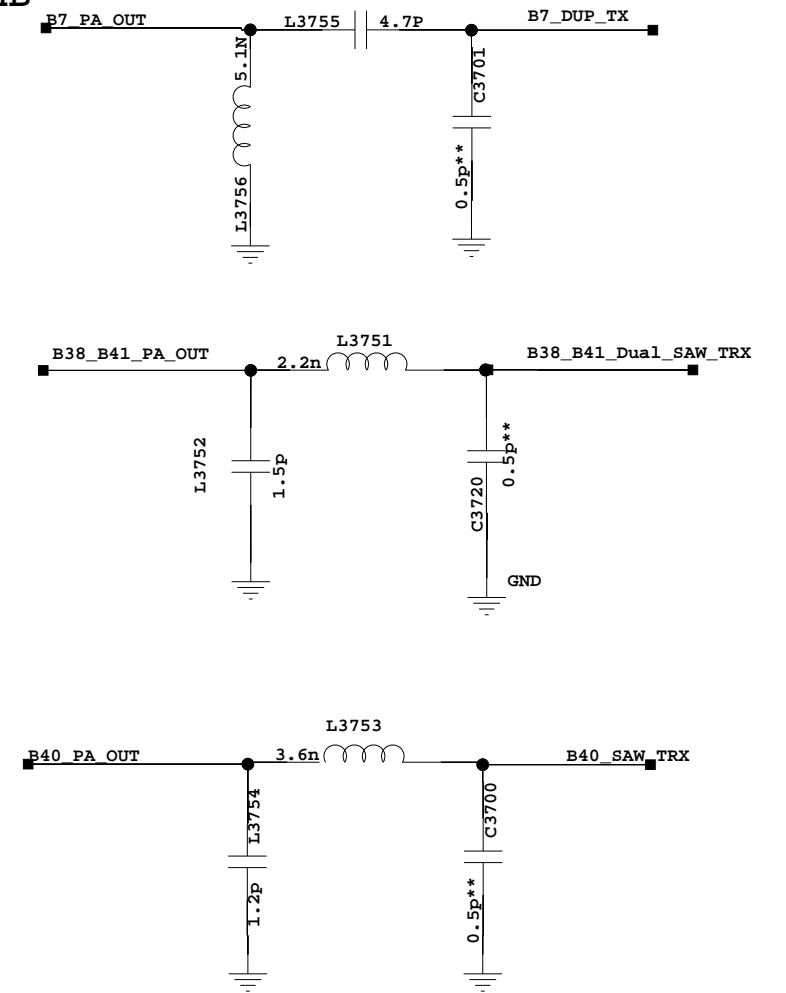

38 TRX_LB_1

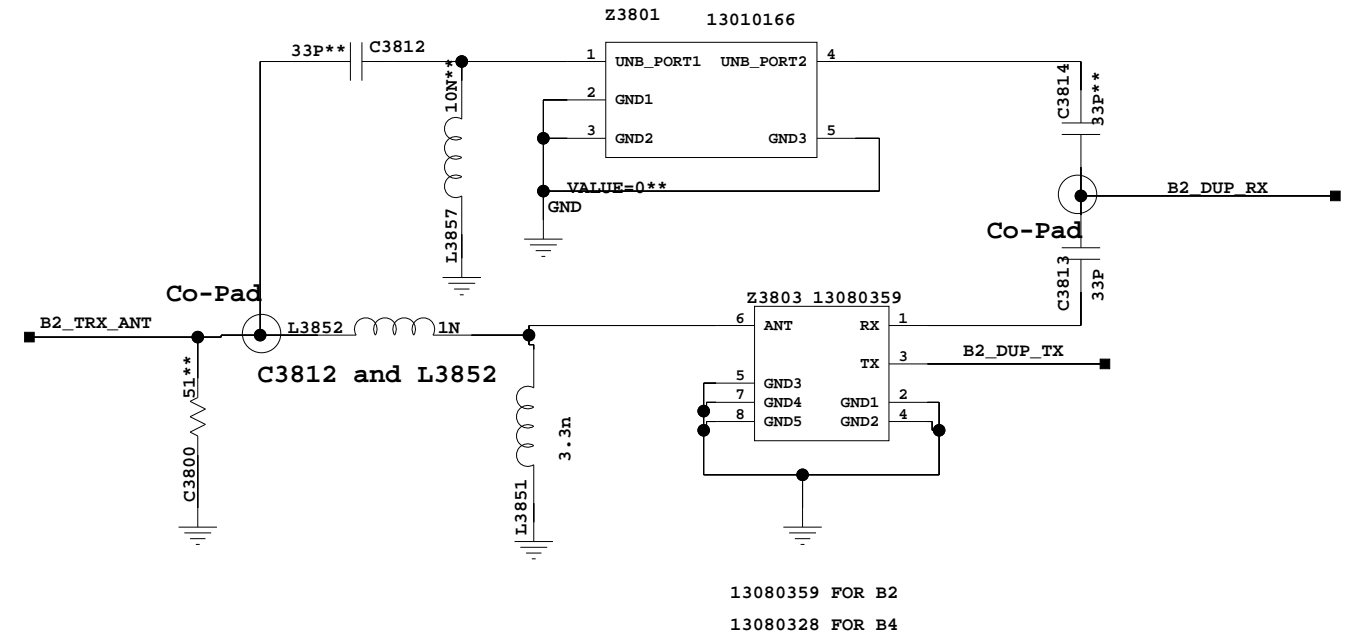
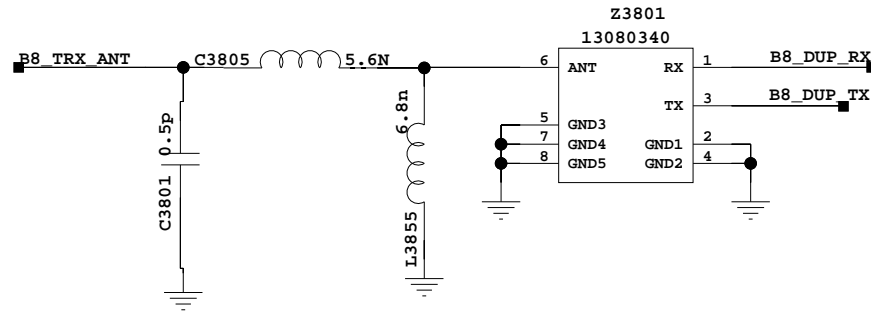
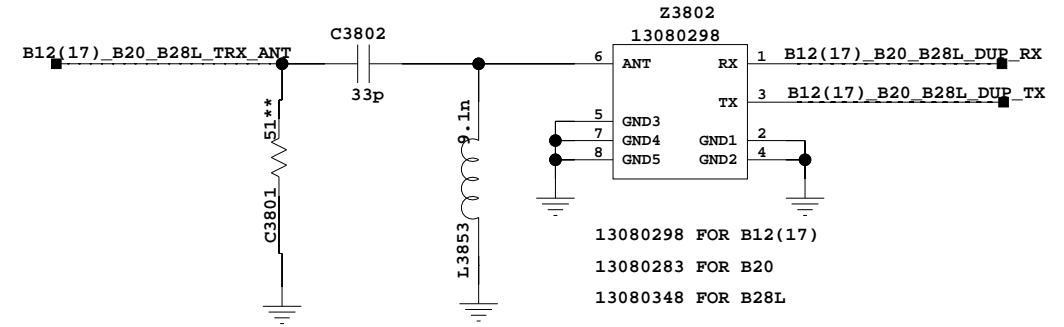
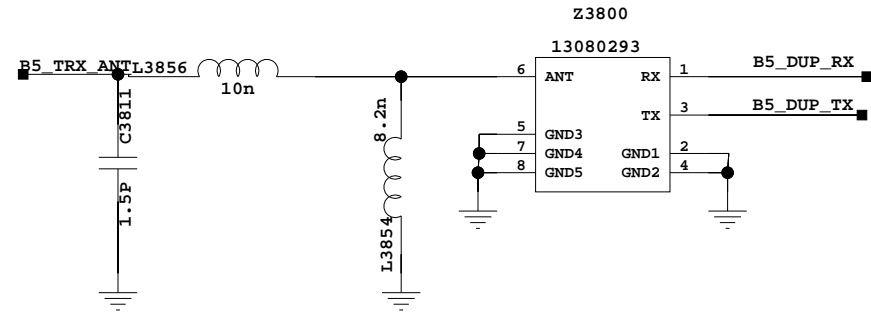

1

2

3

4

5

6

39 TRX_LB_2

A

A

B

B

C

C

D

D

1

2

3

4

5

6

40 TRX_MB_1

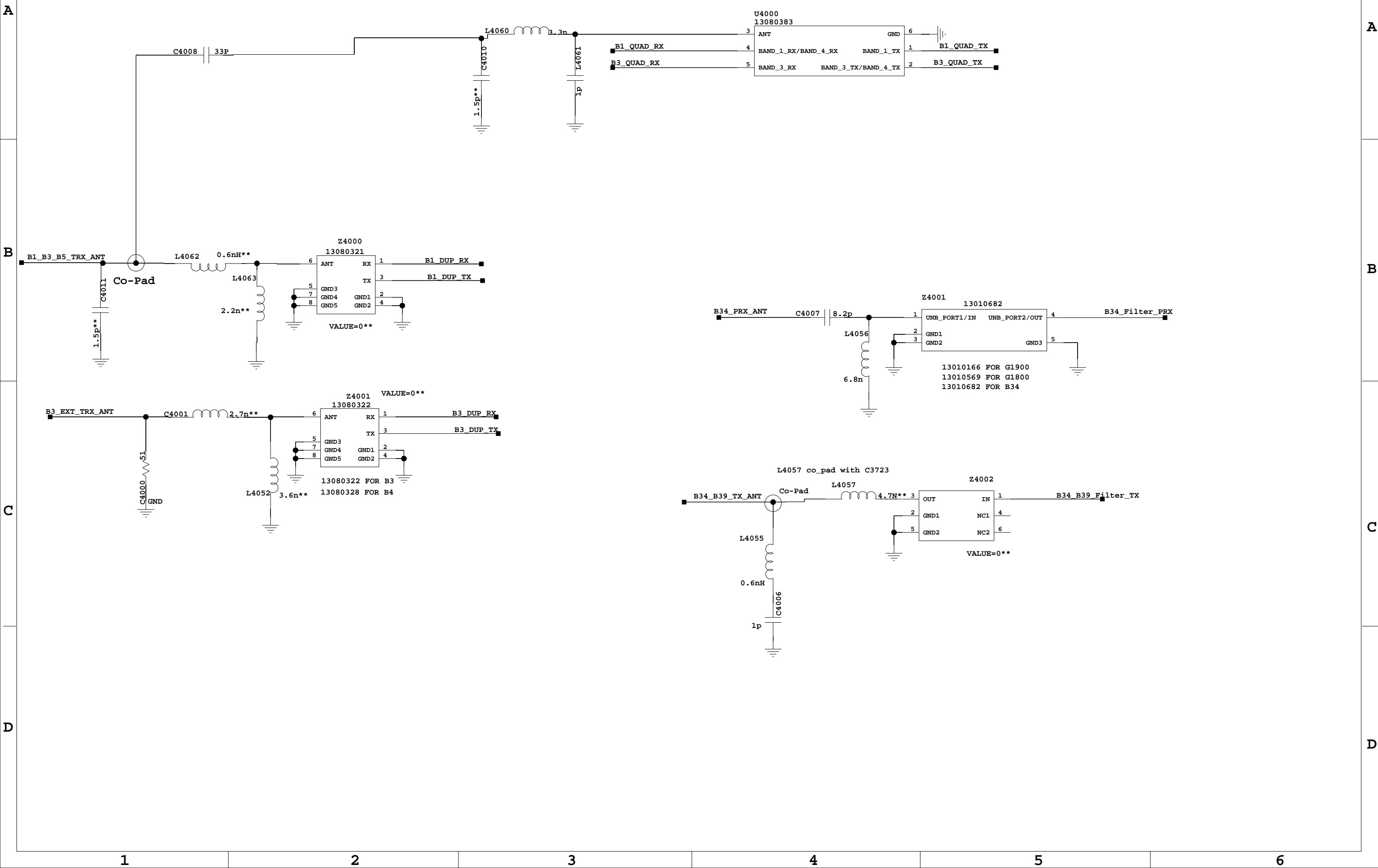

1

2

3

4

5

6

41 TRX_MB_2

A

A

B

B

C

C

D

D

1

2

3

4

5

6

42 TRX_HB_1

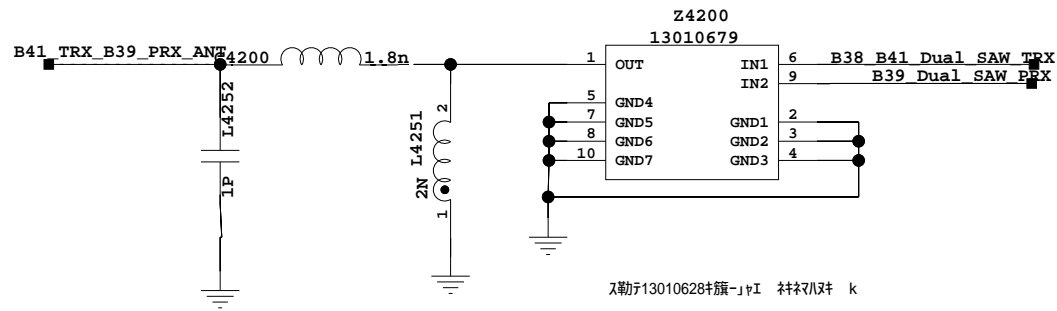
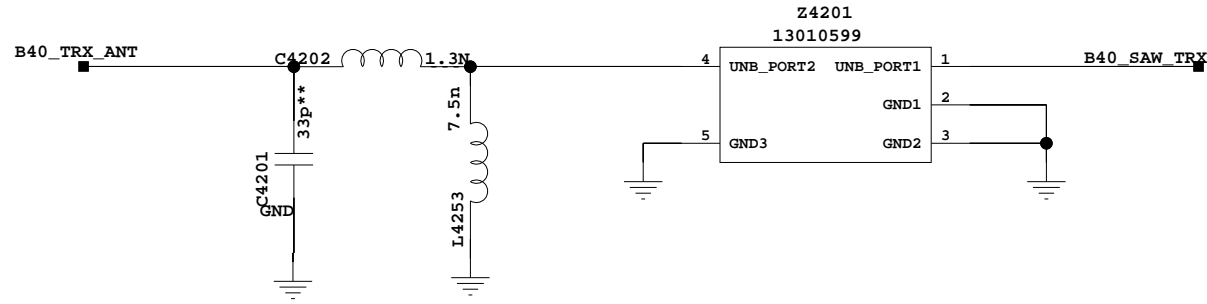
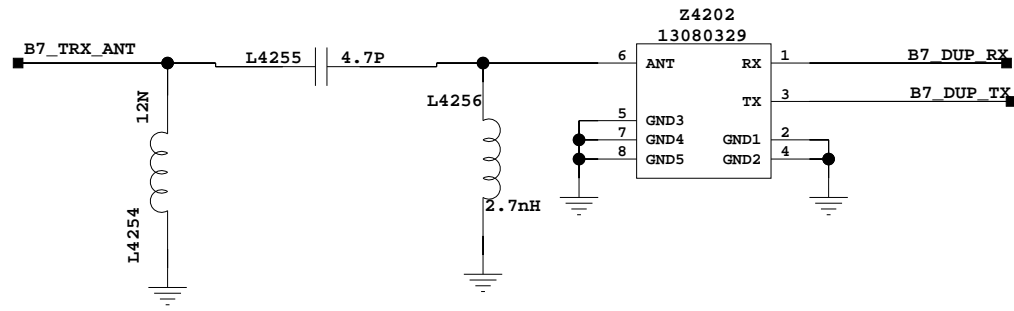

1

2

3

4

5

6

43. TRX_HB_2

A

A

B

B

C

C

D

D

1

2

3

4

5

6

44. PRX_LNA_Module

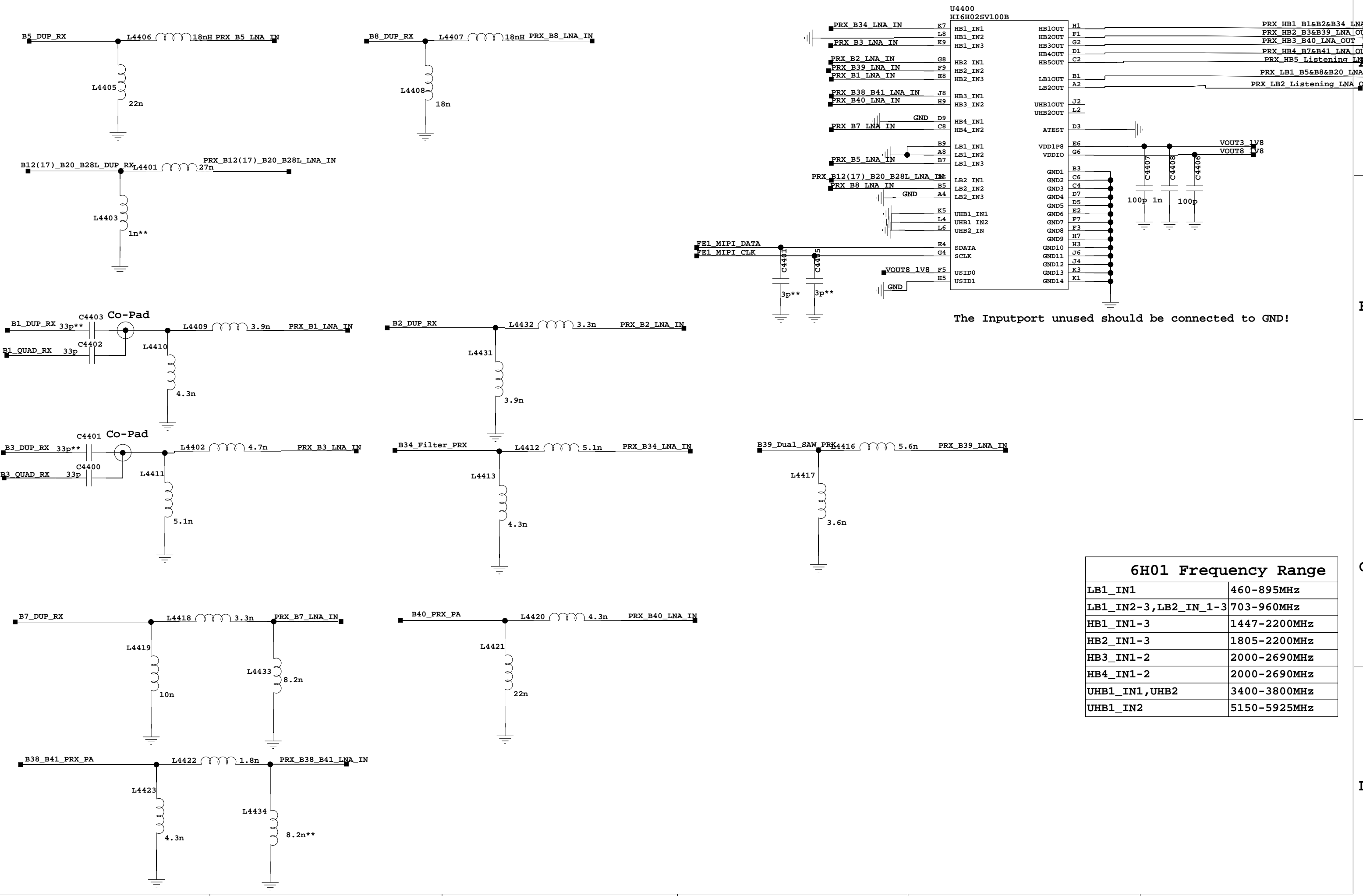

The Inputport unused should be connected to GND!

6H01 Frequency Range	
LB1_IN1	460-895MHz
LB1_IN2-3, LB2_IN_1-3	703-960MHz
HB1_IN1-3	1447-2200MHz
HB2_IN1-3	1805-2200MHz
HB3_IN1-2	2000-2690MHz
HB4_IN1-2	2000-2690MHz
UHB1_IN1, UHB2	3400-3800MHz
UHB1_IN2	5150-5925MHz

45.DRX_SWITCH

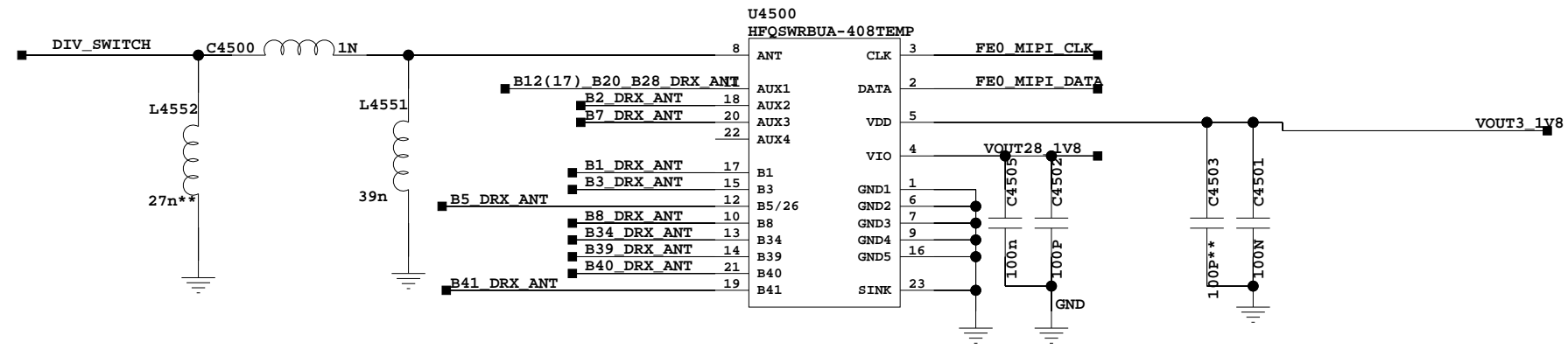

46. DRX_LB

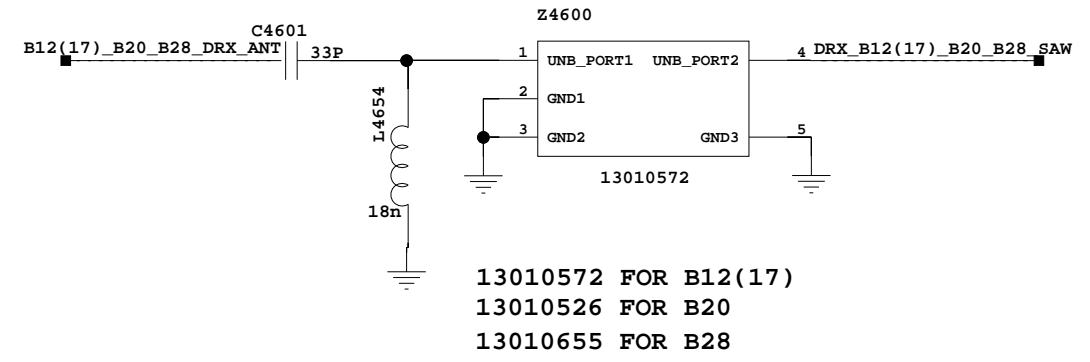

47. DRX_MB

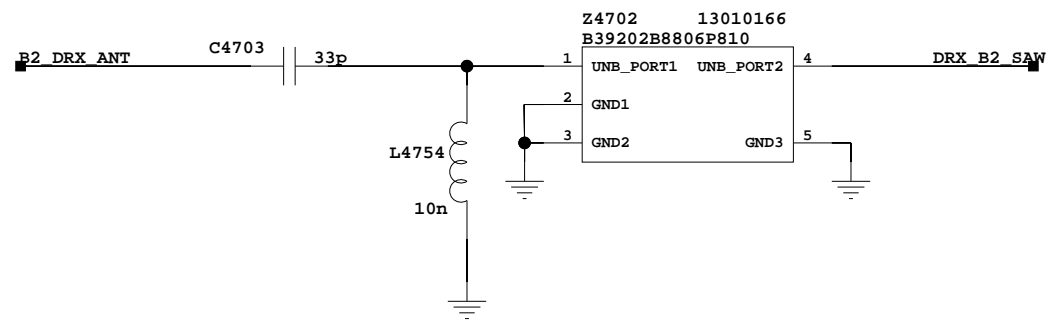

48. DRX_HB

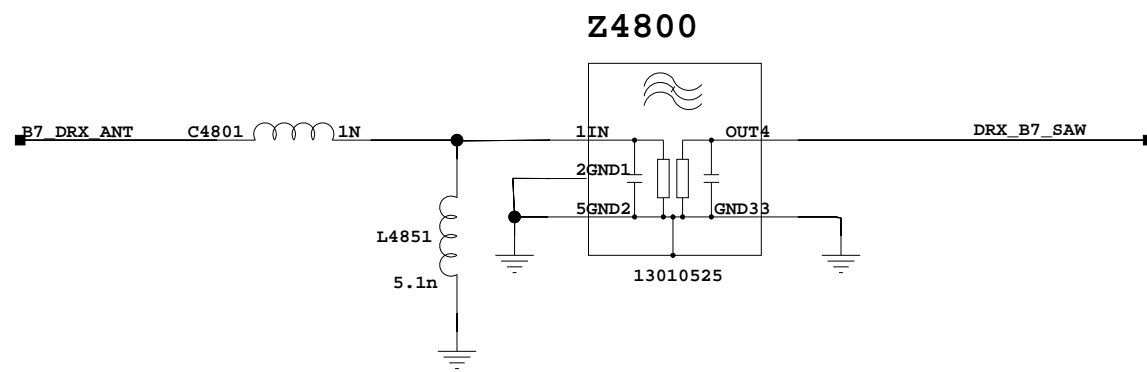

49. DRX_LNA_Module

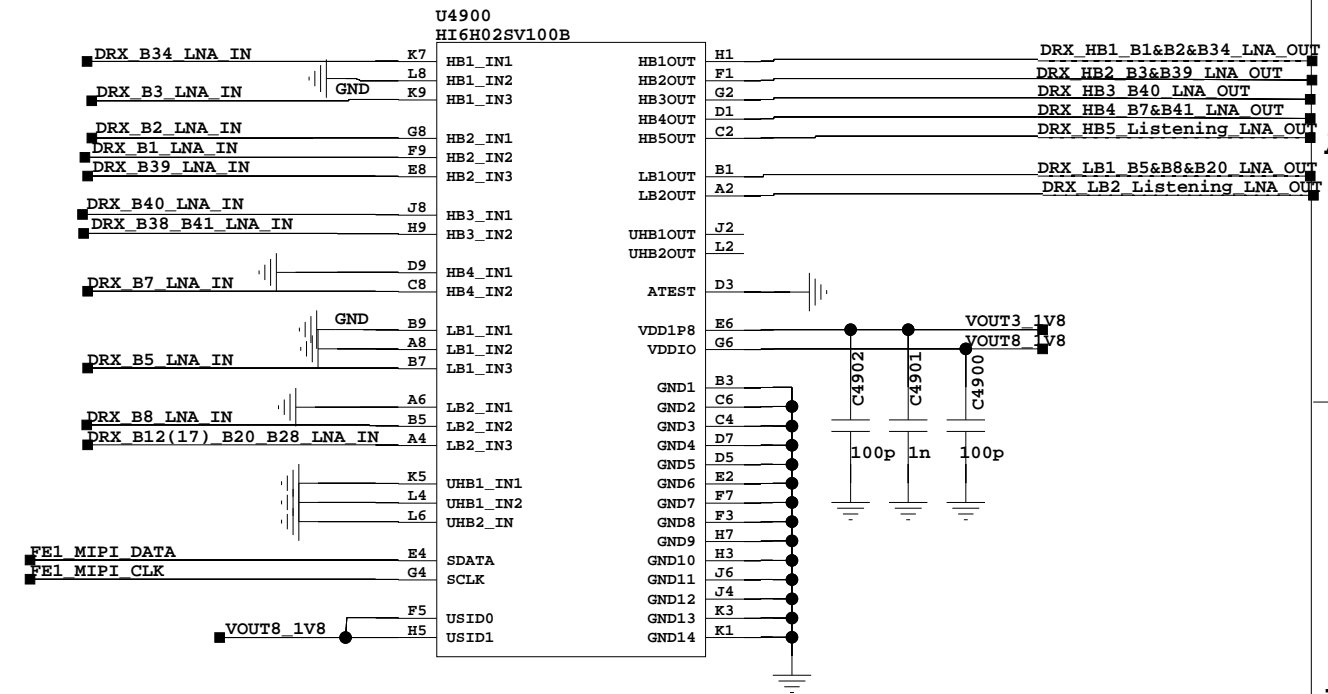
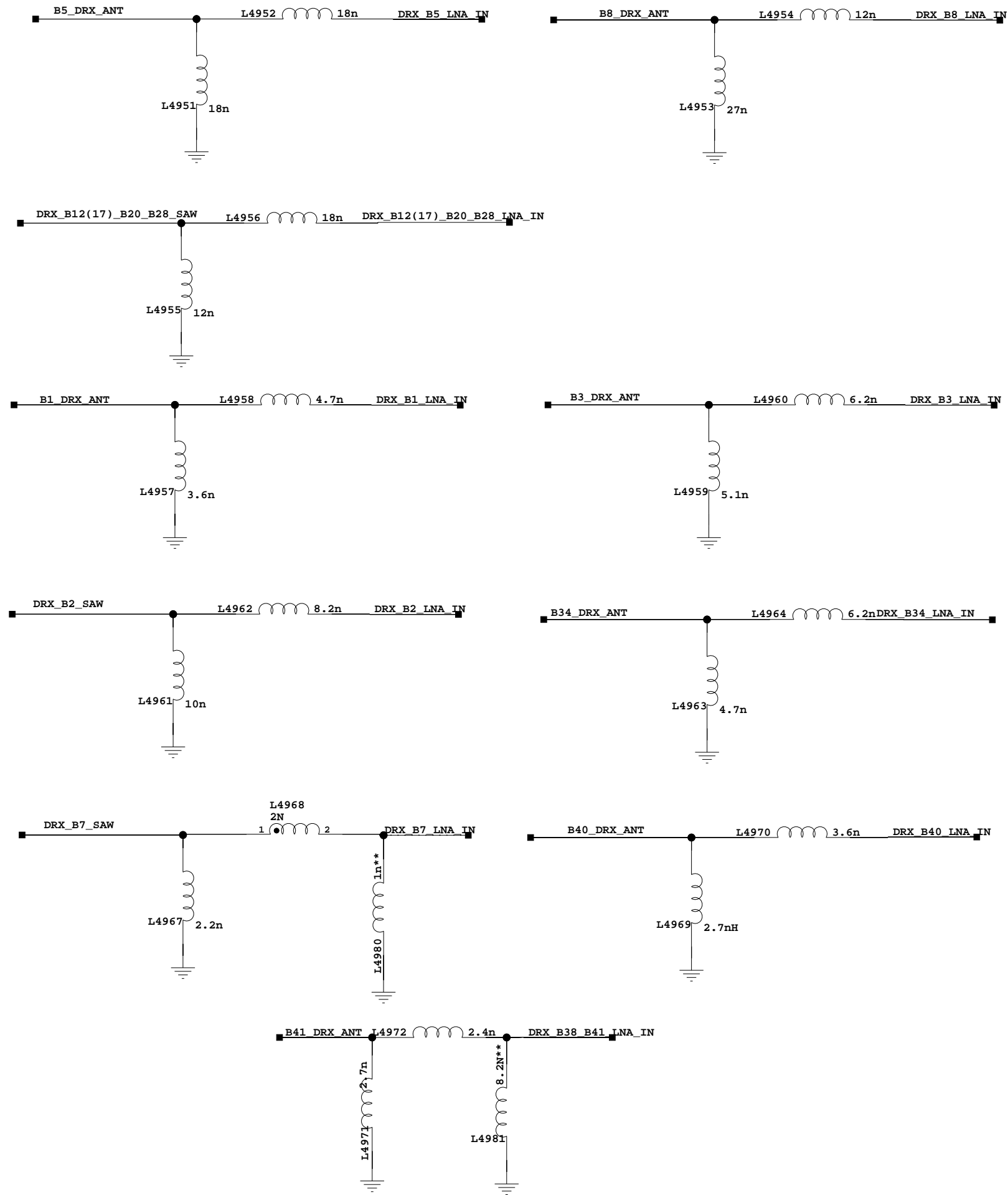

The Inputport unused should be connected to GND!

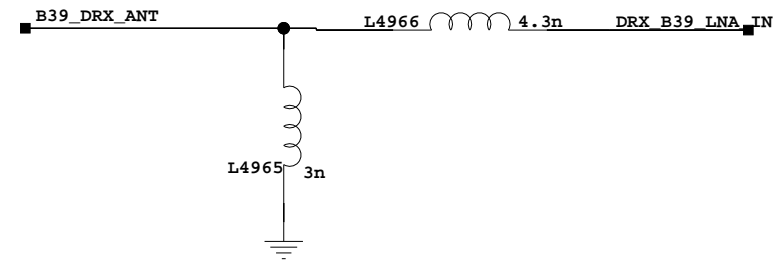

6H01 Frequency Range

LB1_IN1	460-895MHz
LB1_IN2-3, LB2_IN_1-3	703-960MHz
HB1_IN1-3	1447-2200MHz
HB2_IN1-3	1805-2200MHz
HB3_IN1-2	2000-2690MHz
HB4_IN1-2	2000-2690MHz
UHB1_IN1, UHB2	3400-3800MHz
UHB1_IN2	5150-5925MHz

1

2

3

4

5

6

50. Reserved

A

A

B

B

C

C

D

D

1

2

3

4

5

6

1

2

3

4

5

6

51. Reserved_RFIC1

A

A

B

B

C

C

D

D

1

2

3

4

5

6

1

2

3

4

5

6

52. Reserved_APT1

A

A

B

B

C

C

D

D

1

2

3

4

5

6

1

2

3

4

5

6

53. Reserved_MIMO_DRX2

A

A

B

B

C

C

D

D

1

2

3

4

5

6

1

2

3

4

5

6

54. Reserved_DRX3

A

A

B

B

C

C

D

D

1

2

3

4

5

6

1

2

3

4

5

6

55. Reserved_PA_SUB_6G

A

A

B

B

C

C

D

D

1

2

3

4

5

6

1

2

3

4

5

6

56. Reserved_TRX_SUB_6G

A

A

B

B

C

C

D

D

1

2

3

4

5

6

1

2

3

4

5

6

57. Reserved_DRX_SUB_6G

A

A

B

B

C

C

D

D

1

2

3

4

5

6

1

2

3

4

5

6

58.Reserved

A

A

B

B

C

C

D

D

1

2

3

4

5

6

1

2

3

4

5

6

59. Reserved

A

A

B

B

C

C

D

D

1

2

3

4

5

6

60 NC_POWER

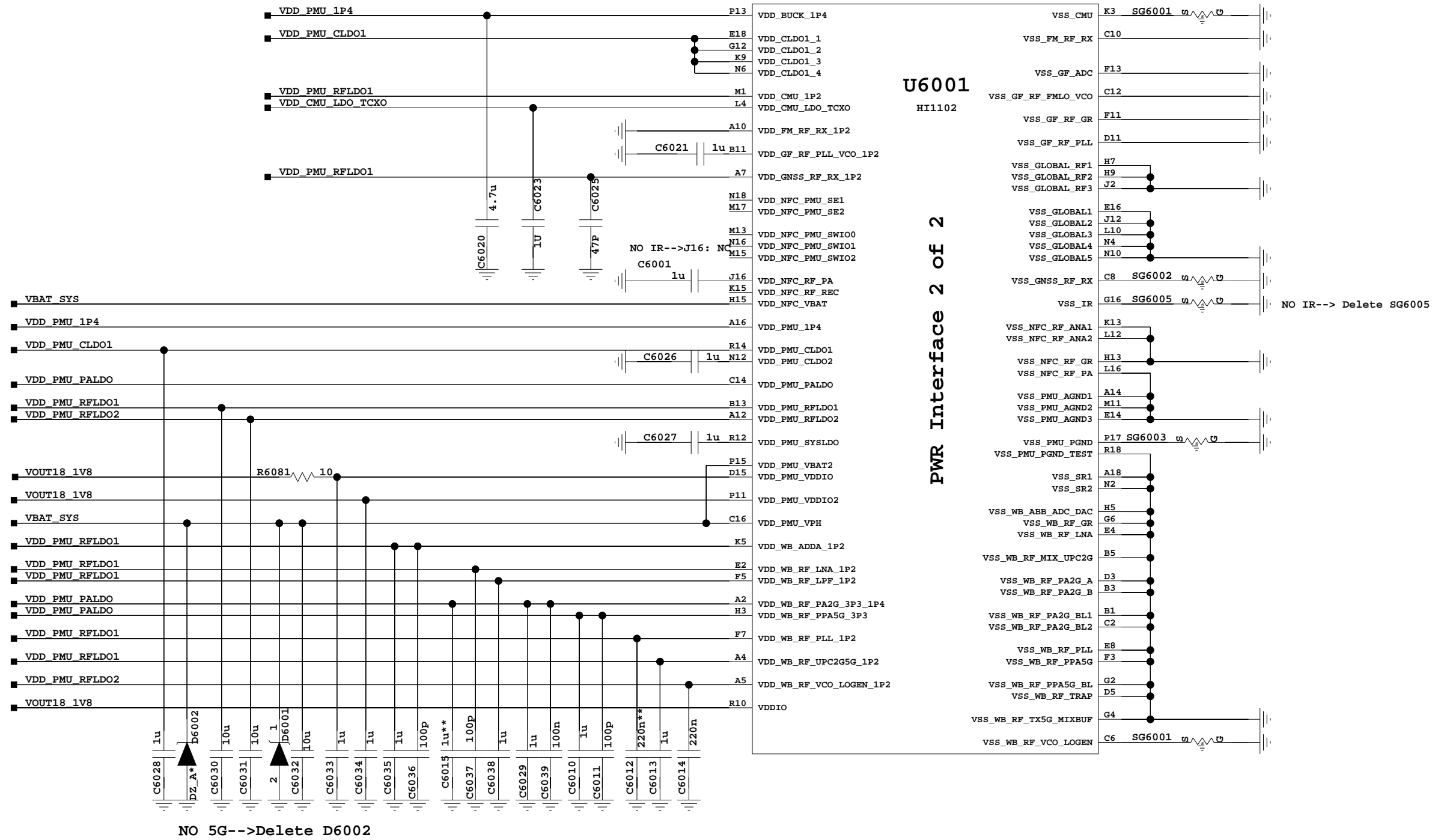

61 NC_BB

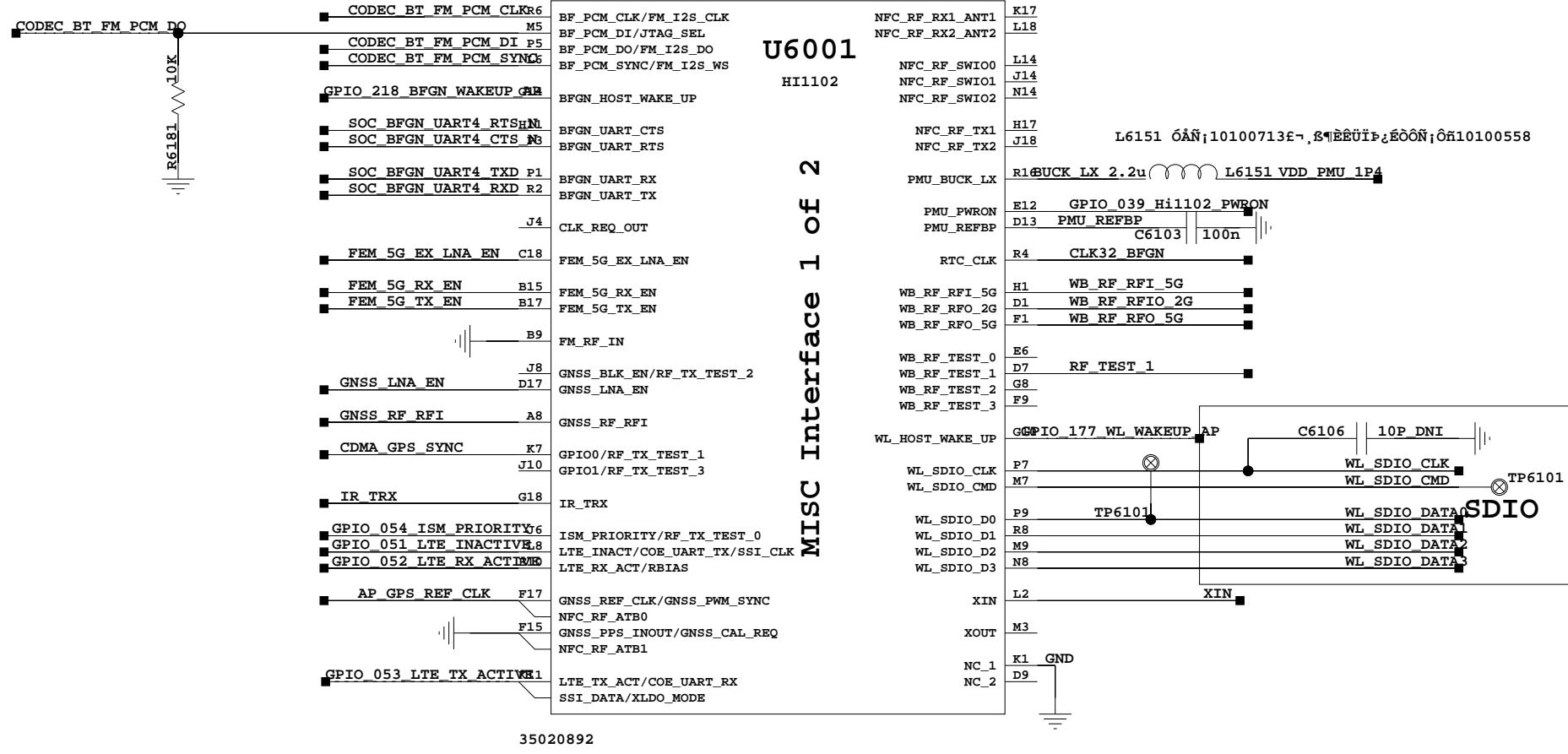

TCXO 38.4MHz

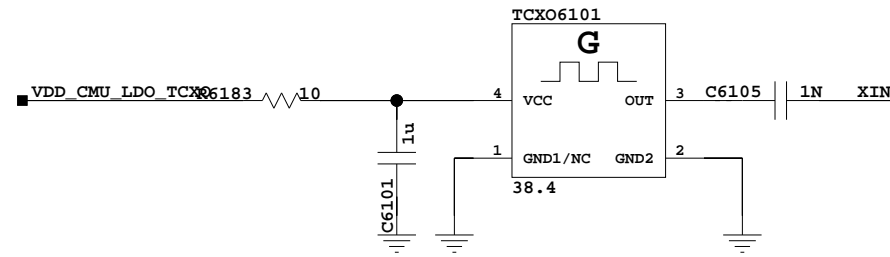

62 NC_FE_WIFI_2G

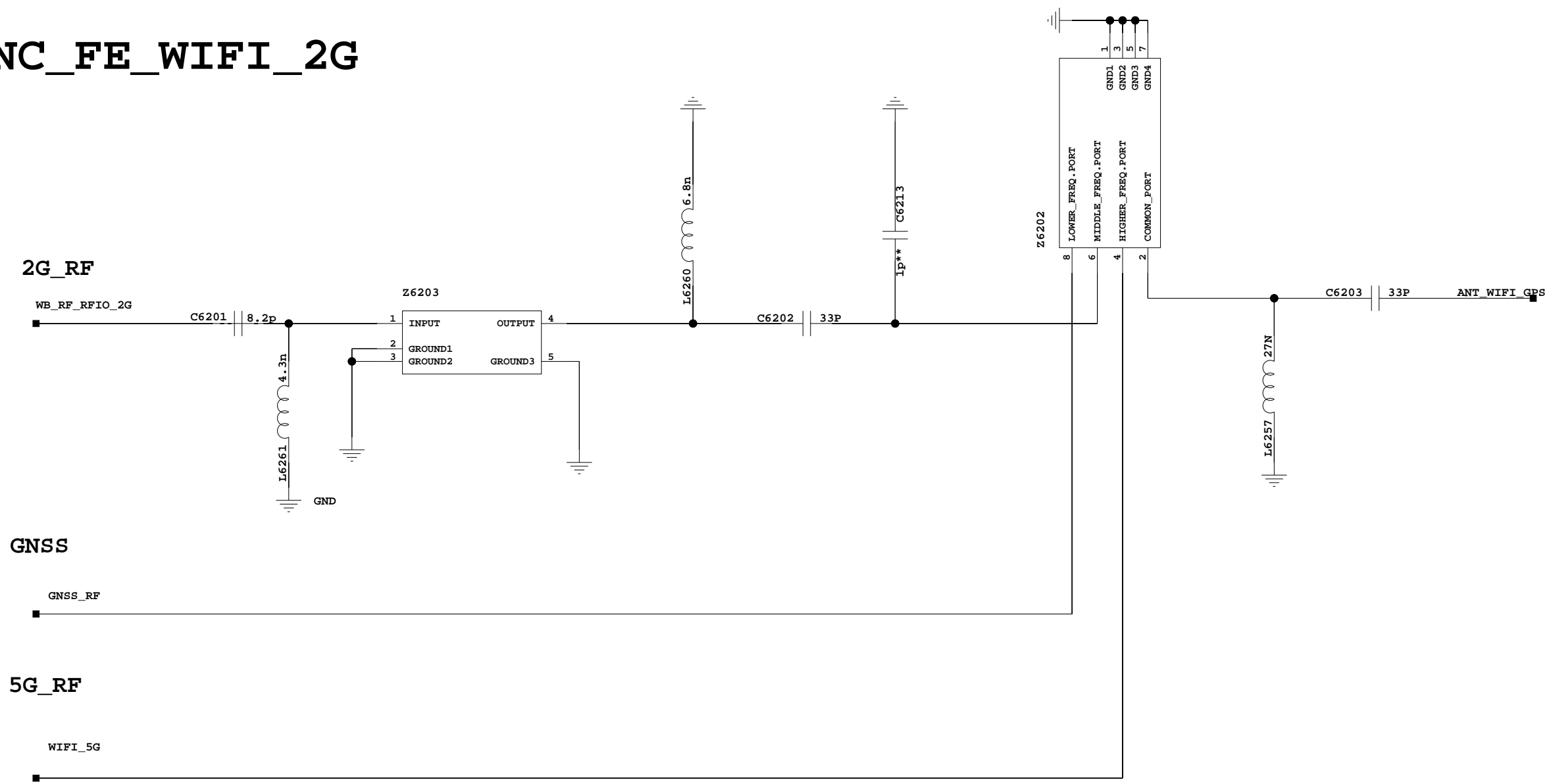

63 NC_FE_WIFI_5G

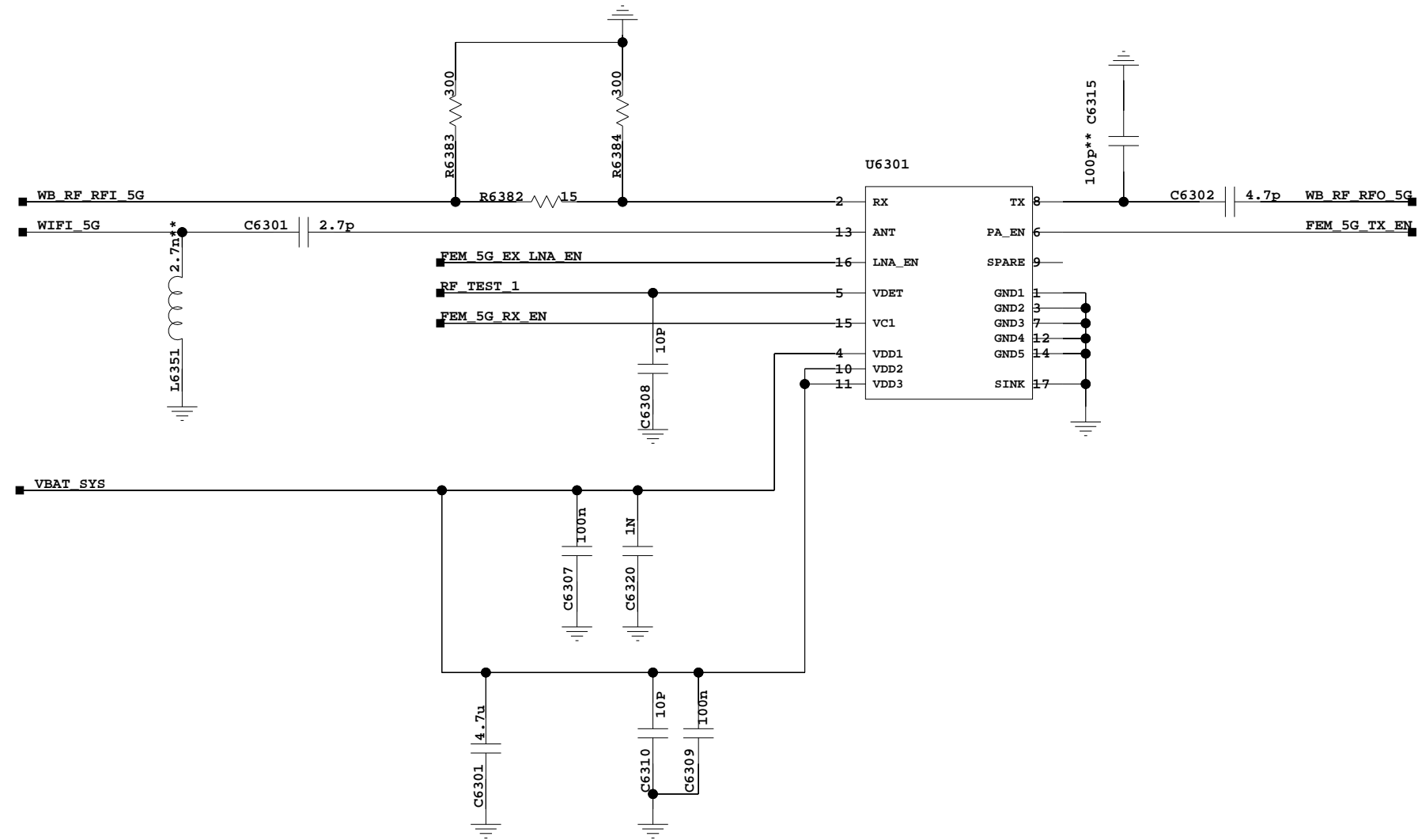

The type and specification of the components refer to the BOM

64 NC_GPS

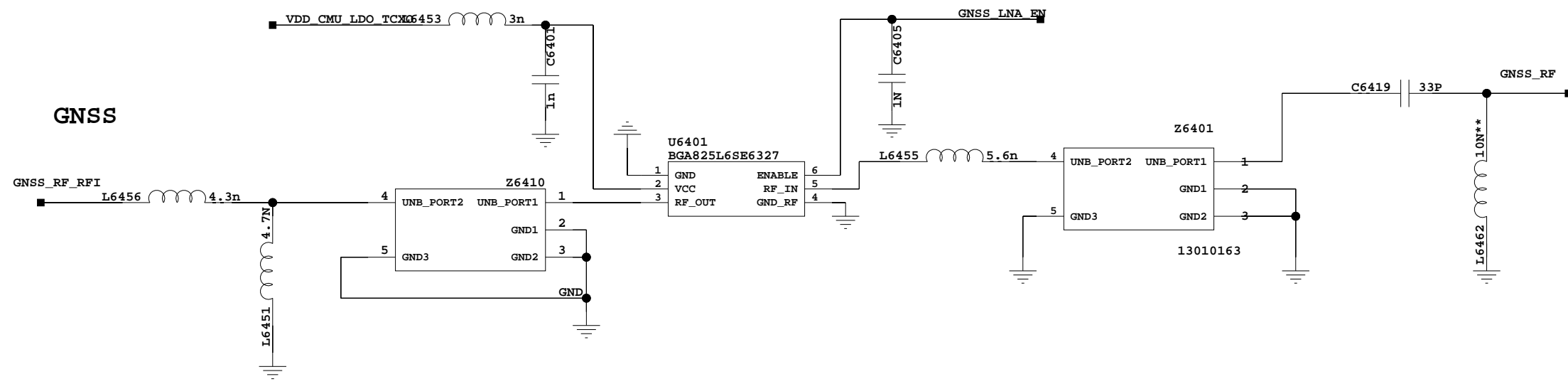

65 RES

1

2

3

4

5

6

A

A

B

B

C

C

D

D

1

2

3

4

5

6

71 NFC Antena

1

2

3

4

5

6

A

A

B

B

C

C

D

D

1

2

3

4

5

6

1

2

3

4

5

6

67 RES

A

A

B

B

C

C

D

D

1

2

3

4

5

6

68. NFC_BB

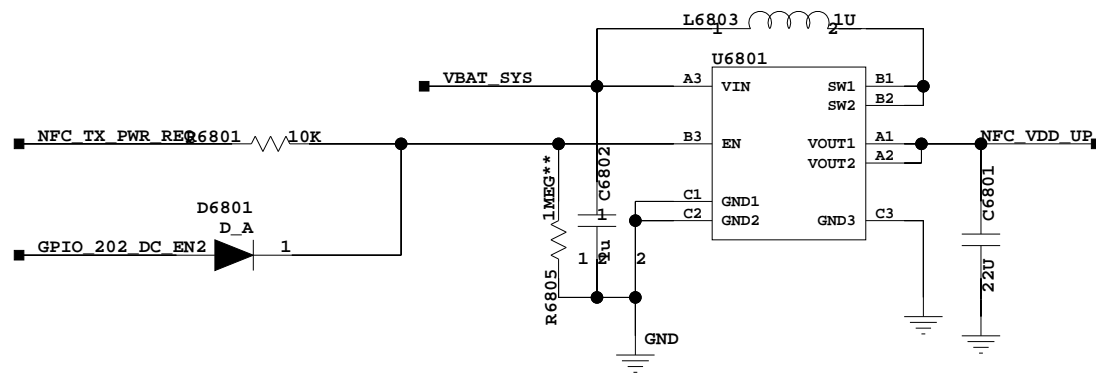
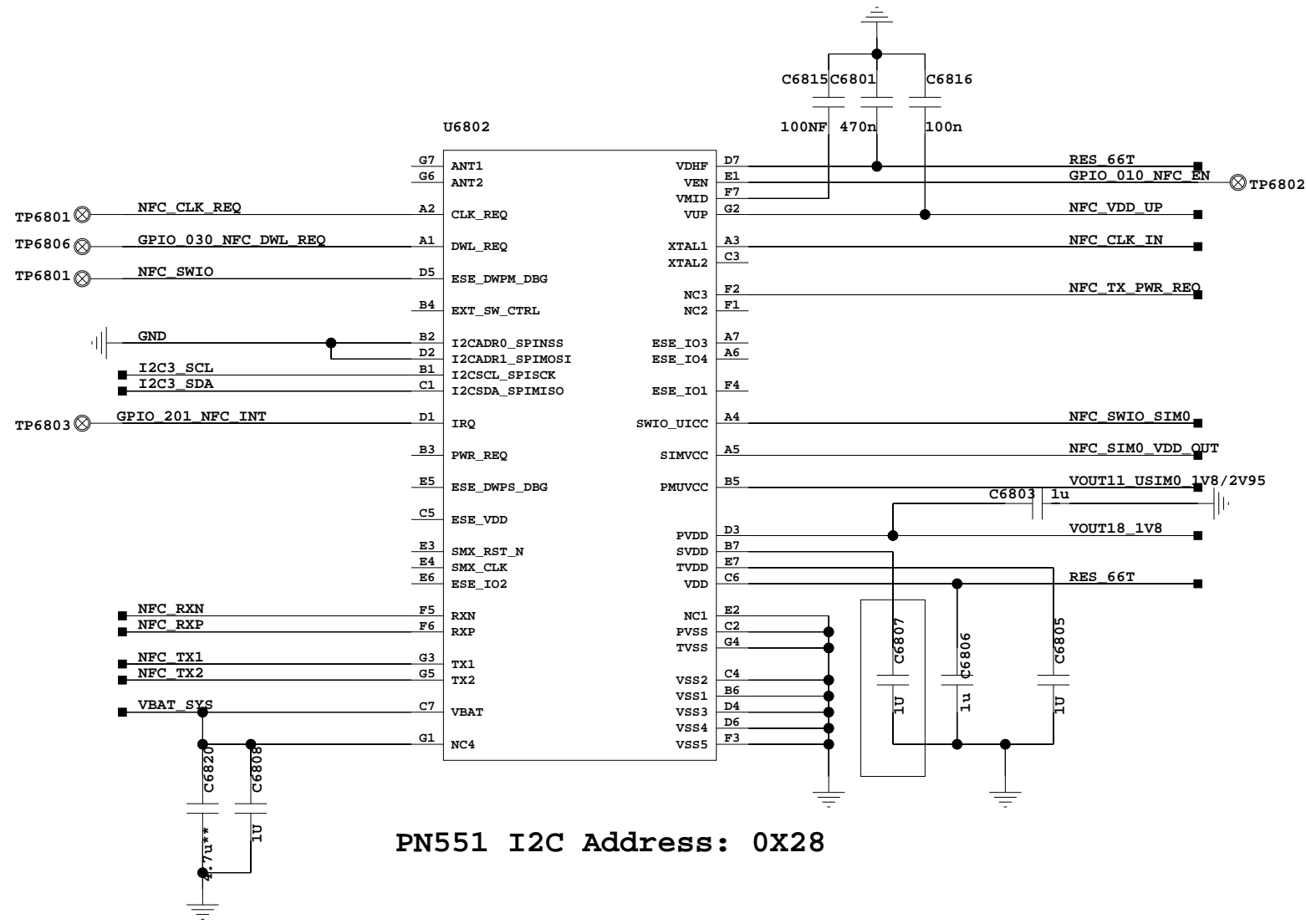

C6802 E/10uF 7英 1uF 及勒ナナナ 精簡ノ10/13

1

2

3

4

5

6

67 RES

A

A

B

B

C

C

D

D

1

2

3

4

5

6

70.Antenna

Div Ant

Switch 3T

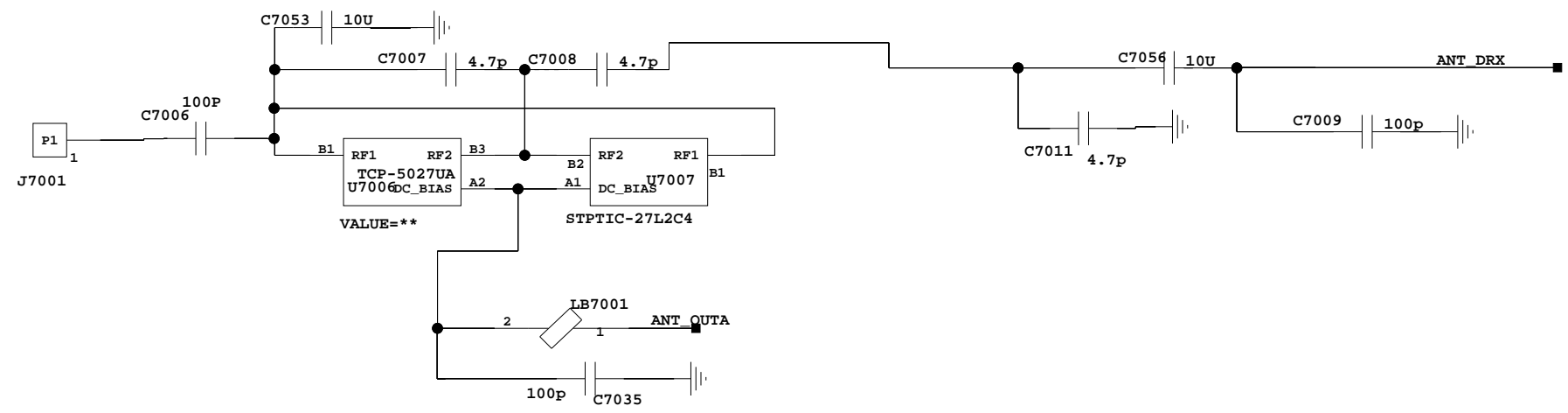
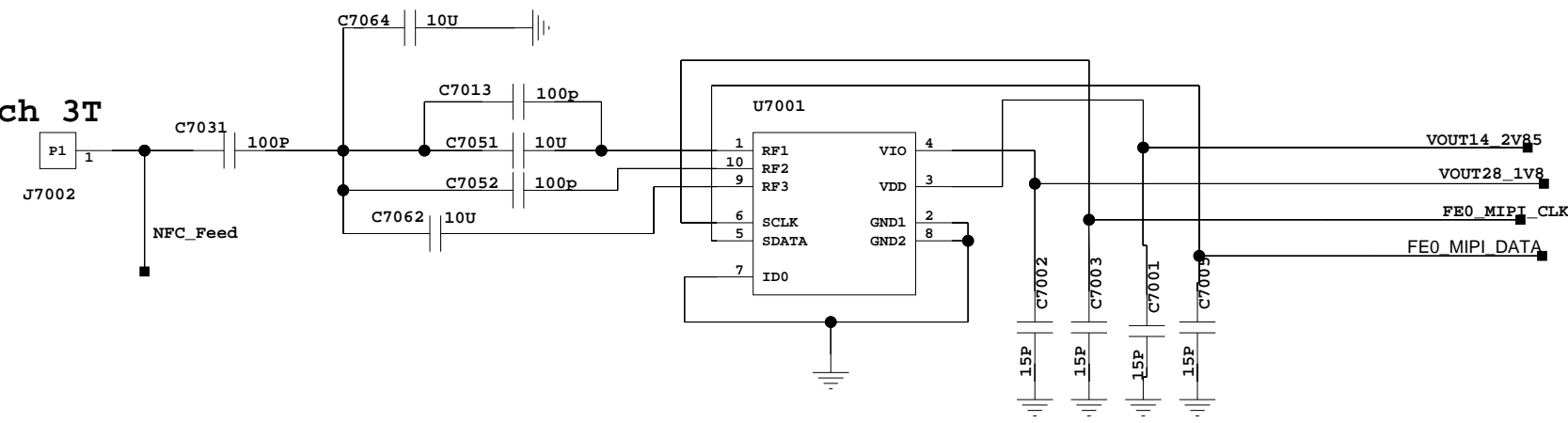

Switch 4T

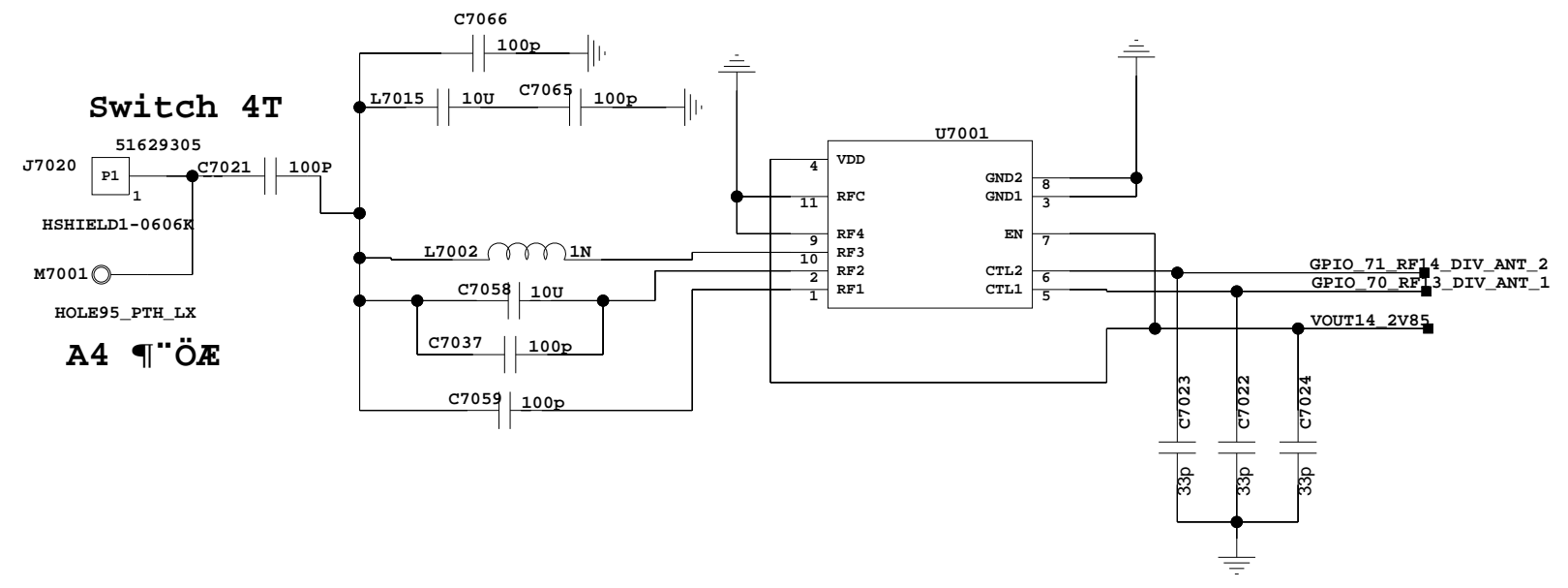

GPS WIFI 2G 5G

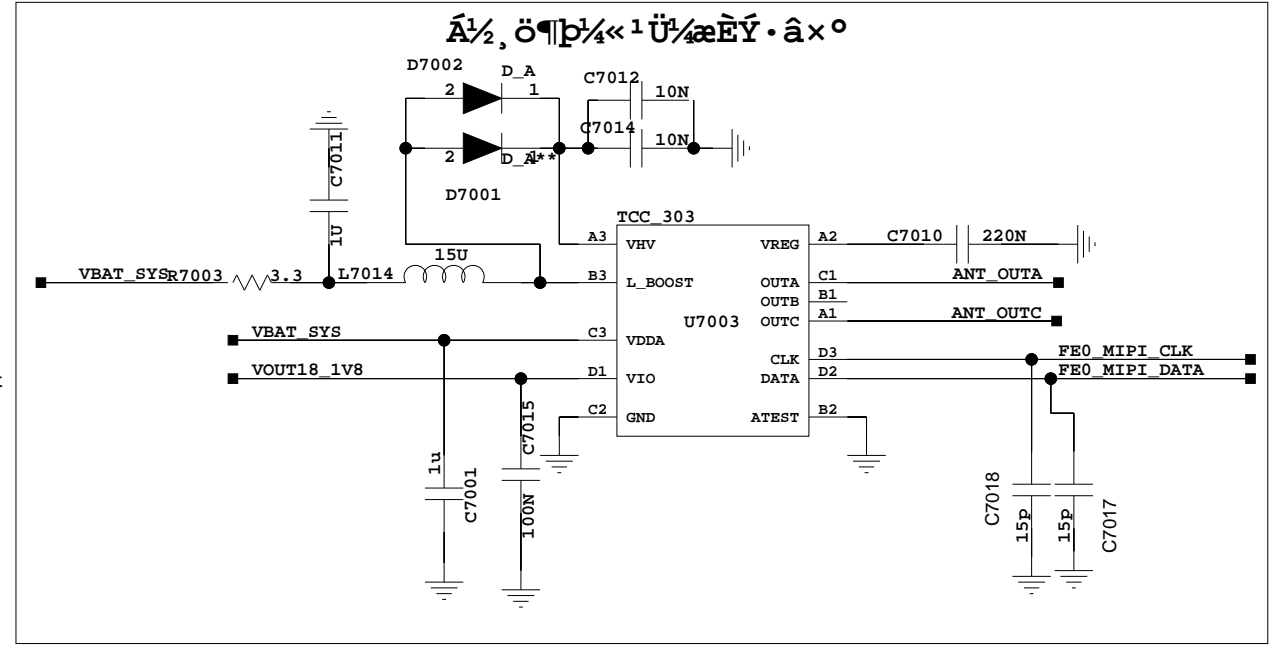
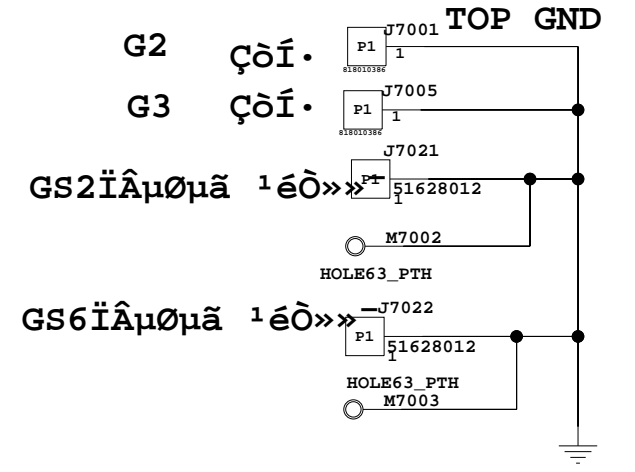
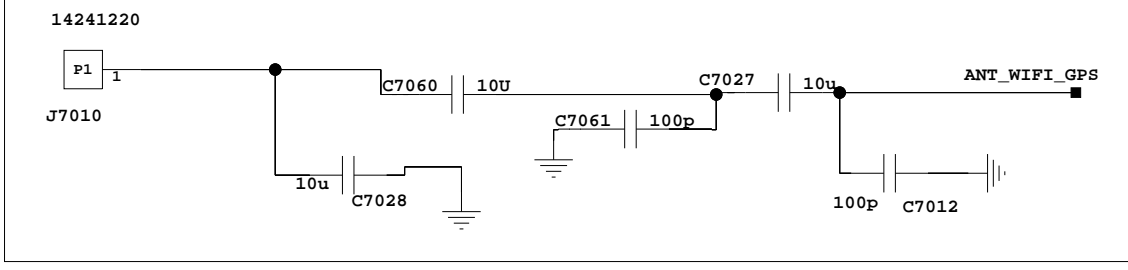

71 NFC Antena

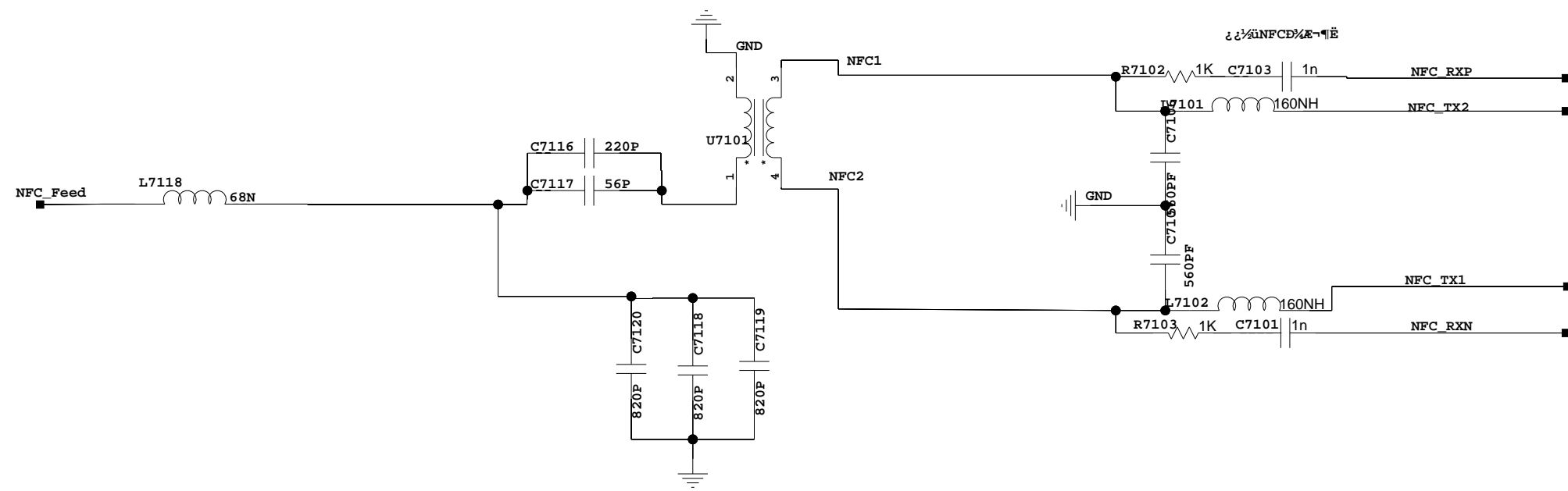

(VIETMOBILE.VN)