



April 7, 2020

Dear HLV Owners,

Re: Sliding Glass Doors

The Building Committee at HLV is recommending that all owners who are contemplating replacing their sliding glass doors in the near future take advantage of the offer from Gulf Coast Builders. This offer extends to all owners this year, and to all buildings even if your building is not part of this summer's project. We have been advised there will be an increase of at least 7 percent next year for sliding doors. All replacement sliding doors that are ordered by June 1st will be installed this summer regardless of building.

Our budgeted insurance costs rose 27% last year and it is expected there will be another increase again next year due to trends in the insurance market. In order for HLV to get a reduction in our insurance premium, all units must meet the hurricane requirements of Dade County. That means all units will be required to have **either** approved hurricane shutters **or** approved hurricane sliding glass doors to meet this requirement. At some point insurance increases may put the Board in a position to require that all units comply with the requirements of Dade County.

HLV's window project is scheduled to be completed by the summer of 2021. Members of the Building Committee strongly suggest that owners thinking about replacing sliding doors take advantage of Gulf Coasts recent offer.

More information regarding cost and the plan for replacement will follow shortly.

Sincerely,

Building Committee, HLV

Tom Cendrowski

Chair



Tuesday, April 07, 2020

IMPORTANT
NOTICE TO OWNERS

REPLACEMENT OF SLIDING GLASS DOORS

Gulf Coast Windows & Doors, a division of Gulf Coast Builders, Inc. is the General Contractor who will be removing and replacing the windows throughout the development. Recognizing the need to replace the sliding glass doors in each condo unit as well, they have agreed to offer Owners at Hidden Lake Villas the opportunity to purchase sliding glass doors at a “group buy” discount. The pricing per door unit includes both the door and installation at a cost most Owners would be unable to obtain if they contracted the work independently. The pricing is limited to three sliding door options as described in the attached specification sheets. The attached sheets include information on the manufacturer, glass type, door design and cost per door unit. Additional information can be obtained from the Contractor. **The pricing is limited to orders placed prior to June 1, 2020 after which the price is expected to increase.**

**FOR MORE INFORMATION, PLACE AN ORDER OR TO VISIT THEIR SHOWROOM,
PLEASE CONTACT:**

**GULF COAST WINDOWS & DOORS
10821 SUNSET PLAZA CIRCLE, UNIT 302
FORT MYERS, FL 33908
239-454-7780**

*****Owners must contract directly through the above Contractor and
not through the Association.***

788 Park Shore Drive, Naples, Florida 34103
Phone: (239) 261-1300 | Fax: (239) 261-5561
Email: Office@HLVcondo.com | Website: www.HLVcondo.com



Group Buy Proposal

February 24, 2020

Hidden Lakes Residents and Association
788 Park Shore Drive
Naples, FL. 34103

Dear Hidden Lake Association and Homeowners:

Thank you for the opportunity to present your condominium with a group buy proposal for your sliding glass doors. In considering our quote, we would like to offer you some information about our company. Gulf Coast Windows and Doors has been in business serving Collier County for over 25 years. We specialize in window and door replacement in condominiums. Our focus has always been in the window and door replacement industry, not in restoration, mirrors, shower doors or storm doors. Therefore, our experience sets us apart from our competition in knowing that our factory trained employees are knowledgeable and focused in window and door replacement and working in a finished environment.

Gulf Coast Windows and Doors does not use sub-contractors or pay piecework for our window or door installations and our employees are fully covered by Workman's Compensation Insurance. We treat your home as if it were our own by providing floor protection from the front door entry to the work area. We cover the furniture in our work area with lightweight plastic for dust protection. We take care to respect building rules and regulations. Inspection reports are created for each unit prior to and after to ensure that each unit is the same as when we entered it. There are many other steps that we perform to ensure each job is well done to your satisfaction. We will have a full time superintendent on site managing all phases of your job from start to finish. Visit our website: www.gulfcoastwindowsanddoors.com or stop by our showroom conveniently located at: 10821 Sunset Plaza Circle Unit 302 Fort Myers, FL 33908. Our showroom hours are Monday thru Friday from 8am -5pm.

10821 Sunset Plaza Circle, Unit 302 | Fort Myers, FL 33908 | Phone (239) 454-7780 | Fax (239) 454-7789
info@gulfcoastwindowsanddoors.com | www.gulfcoastwindowsanddoors.com | LIC #CBC055853



Reviews from our customers from
an accredited review company.
See all of our reviews online at:
www.gulfcoastwindowsanddoors.com



Gulf Coast is consistently Ranked in
the top 100 across the country as a
Specialty Replacement Contractor



Voted the Best Window & Door
Replacement Company by the
News Press Bazaar's Choice Poll

SCOPE OF WORK:

Gulf Coast Windows and Doors is recommending sliding glass doors manufactured by PGT Industries (www.pgtindustries.com). All doors are Impact-Resistant Aluminum frame, Bronze finish Sliding Glass Doors, Series 770. All glass is Impact-Laminated Clear (no tint). All doors will come with nylon rollers and a standard handle.

1 **PGT Impact** Sliding Glass Door 72 x 80, 2 panel/2 track, By-Pass, XO: \$2,497.00
Add: \$124.00 to upgrade to laminated energy shield max low-e (non-insulated)

Note: If a homeowner has impact shutters with a valid building permit then a non-impact door may be installed. In such cases, GCWD can supply and install PGT NON-Impact Aluminum frame, Bronze finish Sliding Glass Doors, Series 670. All glass will be NON-Impact Single Pane (tempered) Clear (no tint).

1 **PGT NON-Impact** Sliding Glass Door 72 x 80, 2 panel/2 track, By-Pass, XO \$2,214.00
Add: \$389.00 to upgrade to non-impact insulated energy shield max low-e (Insulated glass is a requirement if adding low-e)

ALTERNATE MANUFACTURER OPTIONS:

In addition to PGT Industries, GCWD is offering the Hidden Lakes Association alternate manufacturers.

MANUFACTURER ALTERNATE 1:

Manufactured by ES Windows (www.eswindows.com). These doors are Impact-Resistant Aluminum frame, Duranar Bronze finish Sliding Glass Doors, Series EL400. All glass is Impact-Laminated (tempered) Clear (no tint). All doors will come with nylon rollers and the mini-crest handle.

1 **ES Impact** Sliding Glass Door 72 x 80, 2 panel/2 track, By-Pass, XO: \$2,685.00
Add: \$312.00 to upgrade to laminated SB70Xl low-e (non-insulated)

Note: ES Windows does not offer a non-impact door option.

10821 Sunset Plaza Circle, Unit 302 | Fort Myers, FL 33908 | Phone (239) 454-7780 | Fax (239) 454-7789
info@gulfcoastwindowsanddoors.com | www.gulfcoastwindowsanddoors.com | LIC #CBC055853



Reviews from our customers from an accredited review company. See all of our reviews online at: www.gulfcoastwindowsanddoors.com



Gulf Coast is consistently Ranked in the top 150 across the country as a Remodeling Specialty Replacement Contractor.



Voted the Best Window & Door Replacement Company by the News Press Reader's Choice Poll

MANUFACTURER ALTERNATE 2:

Manufactured by WinDoor Inc. (www.windoorinc.com). These doors are Impact-Resistant Aluminum frame, Bronze finish Sliding Glass Doors, Series 7000. All glass is Impact-Laminated Clear (no tint). All doors will come with nylon rollers and a standard handle.

1 **WinDoor Impact** Sliding Glass Door 72 x 80, 2 panel/2 track, By-Pass, XO: \$2,896.00

Add: \$257.00 to upgrade to laminated SB70XL low-e (non-insulated)

Note: If a homeowner has impact shutters with a a valid building permit then a non-impact door may be installed. In such cases, GCWD can supply and install WinDoor NON-Impact Aluminum frame, Bronze finish Sliding Glass Doors, Series 7000. All glass will be NON-Impact Single Pane (tempered) Clear (no tint).

1 **WinDoor NON-Impact** Sliding Glass Door 72 x 80, 2 panel/2 track, By-Pass, XO \$2,581.00

*Add: \$593.00 to upgrade to non-impact insulated SB70XL low-e
(Insulated glass is a requirement if adding low-e)*

Building Permit Fees \$350 per unit. Each unit will be permitted individually.

Additional Notes:

- This proposal is based on a group buy and all doors need to be ordered and installed at the same time.
- The cut-off date to sign up is June 1st, 2020.
- This proposal is based on a late Summer-early Fall 2020 installation. The door installation will start after the window installation has concluded for the association.
- All pricing includes the removal of existing doors and installation of new products, and applicable taxes and labor.
- All of these doors will be installed using Dymonic 100 Bronze Polyurethane Security Sealant and Acryl-R Acrylic Self-Leveling Sealant.
- Installation warranty is good for 5 years.
- This proposal does not include any smoke detector work that may be required by The City of Naples.

10821 Sunset Plaza Circle, Unit 302 | Fort Myers, FL 33908 | Phone (239) 454-7780 | Fax (239) 454-7789
info@gulfcoastwindowsanddoors.com | www.gulfcoastwindowsanddoors.com | LIC #CBC055853



Reviews from our customers from
an accredited review company.
See all of our reviews online at:
www.gulfcoastwindowsanddoors.com



550 Gulf Coast is consistently Ranked in
the top 100 across the country as a
Remodeling Specialty Replacement Contractor



Voted the Best Window & Door
Replacement Company by the
News Press Reader's Choice Poll

- No painting, no wallpaper, no alarm work, no fire sprinkler work, no electrical and no tile work. Any tile repair, tile is to be supplied by the homeowner for repair by GCWD.
- The homeowner is advised to remove any window treatments prior to the installation. If the homeowner is not able to remove their own window treatments, GCWD will remove them and reinstall to the best of our ability but if there are damaged blinds or brackets, GCWD will not be responsible for damaged window treatments.
- Please see attached Manufacturer Warranties.

Terms & Conditions: All material is guaranteed to be as specified. All work to be completed in a professional manner according to standard practices. Any alteration or deviation from above specifications involving extra costs will be executed only upon written orders, and will become an extra charge over and above the estimate. All agreements contingent upon strikes, accidents or delays beyond our control. Owner to carry fire, tornado and other necessary insurance. Our workers are fully covered by Workmen's Compensation Insurance.

Payment Terms: The customer shall pay a 30% deposit for the approved work as outlined in this proposal. **Add a 2% convenience fee if paying by credit card.** Final payment is due upon completion of the job. Any payment not made within 30 days of job completion date shall incur a late payment charge of 1.5% per month of the total balance due. Failure to pay in full upon job completion within the agreed upon terms will result in a construction lien against your property according to Florida's Construction Lien Law (Sections 713.001-713.37, Florida Statutes). The final balance will be invoiced upon completion of work and upon all required inspections passing with the appropriate building department. Gulf Coast Windows and Doors will withhold the appropriate dollar amount from the final invoice pending any manufacturing issues not applicable to anything within ASTM industry standards as stated by the manufacturers. All manufacturing issues will be handled accordingly and once resolved, the homeowner is responsible for paying the said withheld amount. Payment may be available from the Florida Homeowners' Construction Recovery Fund if you lose money on a project performed under contract, where the loss results from specified violations of Florida law by a licensed contractor. For information about the recovery fund and filing a claim, contact the Florida Construction Industry Licensing Board (850) 487-1395, Division of Professions Construction Licensing Board, 1940 North Monroe St., Tallahassee, FL 32399.

Jessica Vance

02/25/2020

Gulf Coast Builders Inc.
Sales Associate

Date Signed

10821 Sunset Plaza Circle, Unit 302 | Fort Myers, FL 33908 | Phone (239) 454-7780 | Fax (239) 454-7789
info@gulfcoastwindowsanddoors.com | www.gulfcoastwindowsanddoors.com | LIC #CBC055853



Reviews from our customers from
an accredited review company.
See all of our reviews online at:
www.gulfcoastwindowsanddoors.com



Gulf Coast is consistently Ranked in
the top 150 across the country as a
Remodeling Specialty Replacement Contractor



Voted the Best Window & Door
Replacement Company by the
News Press Reader's Choice Poll

DOORS

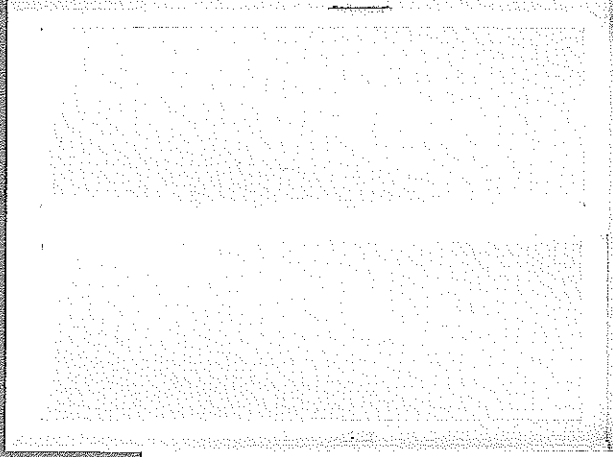

Preferred Sliding Glass Door (SGD770)

Expansions of up to 40 feet

- Amazing, uninterrupted views and a great source of natural light

Panels up to 4' x 10' or 5' x 8'

- Sizes available for every opening

By-pass, pocket, and 90-degree or 135-degree corner door configurations

- Customizable with multiple tracks from 2 to 8 panels

Dual-point locking mechanism

- Provides added security for your home by restricting panels from being lifted off the tracks

Heavy-duty tandem rollers

- Allow easy opening with just your fingertips

Hidden installation and assembly screws

- Deliver a sleek, finished appearance

Raised pull handles or recessed pulls available

Optional screens available

- Standard or box screen



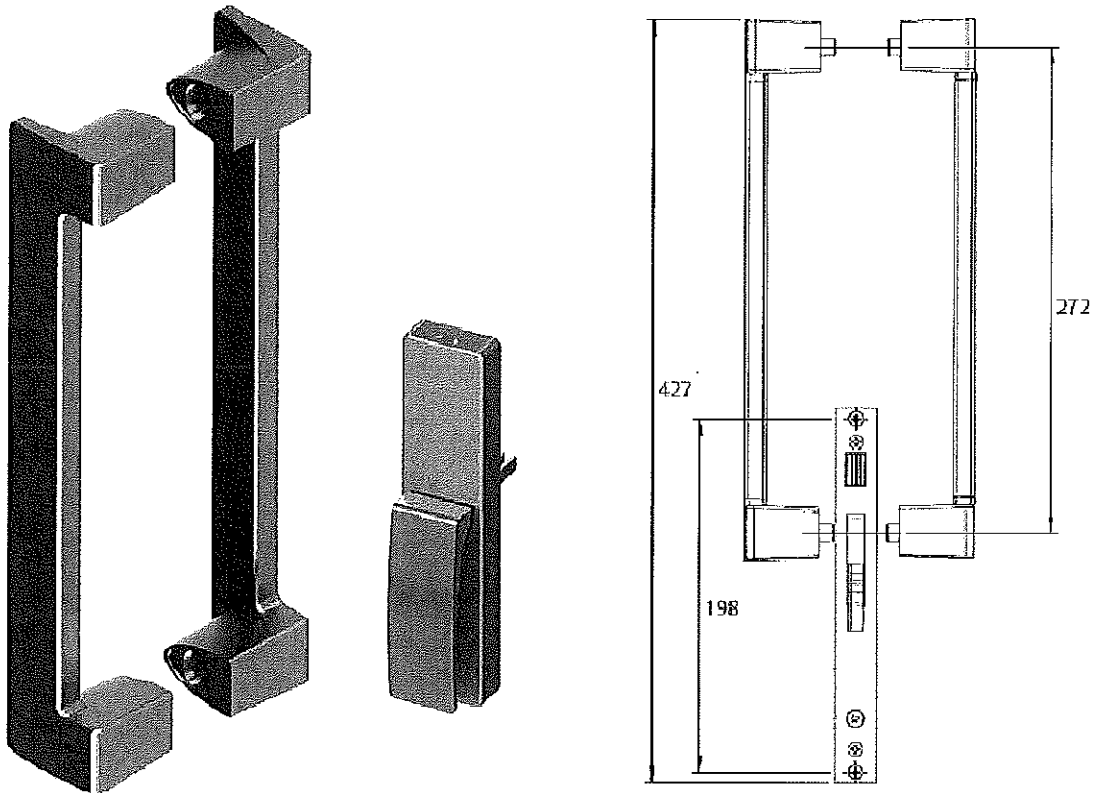

Features

- New Zealand designed and made
- Deadbolt locking
- Can be keyed alike with other Crest hardware in the home for one key convenience
- Anti-lift design
- Anti-slam mechanism protects accidental damage to hook bolt when door is closed
- Adjustable strike
- Stainless steel forend plate
- Robust design
- Built to withstand a 4kN force entry load and 100,000 latching cycles
- Compatible with a range of Euro Cylinders

Application

- Suitable for Residential, Architectural and Designer Thermal suites

Options

- Cylinder and turnknob

EL-400

The EL-400 is a sliding glass door with a 4 9/16" frame profile. This product meets the most stringent specifications and, with its attractive design and three-track frame, is ideal for a wide range of applications.

System Description

- Large missile impact rated
- 4 9/16" Frame depth
- Configurations: XO, OX, XX, OXO, OXXO, XXXX, OXXXXO
- Water infiltration: 12 psf
- Design load: +80/-80 psf
- Maximum size: 288" X 108"
- U-value:
 - IGU-0.52
3/16" clear SB60 (#2) + 3/8" Air Spacer + 3/16" clear +
0.090" PVB + 3/16" Low E (#6)
 - LG-1.04
3/16" clear + 0.09" PVB + 3/16" clear
- Insulating laminated glass: 3/16" + 3/8" spacer + 3/16" +
0.09" interlayer + 3/16"
- Laminated glass: 3/16" + 0.09" interlayer + 3/16"
- Minimum width for accessibility is 75 5/8" on OX/XO
configuration and 81 7/8" on XX configuration

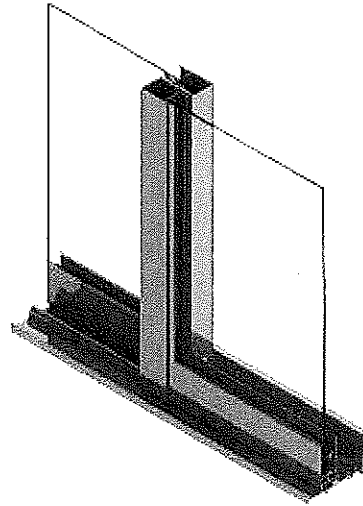

Features

- Adjustable tandem polyamide needle bearing rollers
- Three track and four track frame option
- Saflex PVB, Kuraray PVB, Vanceva Storm and Sentry glass Plus interlayer options
- Pocket configuration available

