

Student Name _____

P



**Grade 6
Mathematics
Test Booklet**

Practice Test

TEST BOOKLET SECURITY BARCODE

Section 1

(Non-Calculator)

Directions:

Today, you will take Section 1 of the Grade 6 Mathematics Practice Test. You will not be able to use a calculator.

Read each question. Then, follow the directions to answer each question. Mark your answers by completely filling in the circles in your answer document. Do not make any pencil marks outside of the circles. If you need to change an answer, be sure to erase your first answer completely. If a question asks you to show or explain your work, you must do so to receive full credit. Only responses entered within the space provided will be scored.

If you do not know the answer to a question, you may go on to the next question. If you finish early, you may review your answers and any questions you did not answer in this section ONLY. Do not go past the stop sign.

Directions for Completing the Answer Grids

1. Work the problem and find an answer.
2. Write your answer in the boxes at the top of the grid.
3. Print only one number or symbol in each box. Do not leave a blank box in the middle of an answer.
4. Under each box, fill in the circle that matches the number or symbol you wrote above. Make a solid mark that completely fills the circle.
5. Do not fill in a circle under an unused box.
6. Fractions cannot be entered into an answer grid and will not be scored. Enter fractions as decimals.
7. See below for examples on how to correctly complete an answer grid.

EXAMPLES

To answer -3 in a question, fill in the answer grid as shown below.

-	3					
●						
○	○	○	○	○	○	○
○	1	1	1	1	1	1
○	2	2	2	2	2	2
●	3	3	3	3	3	3
○	4	4	4	4	4	4
○	5	5	5	5	5	5
○	6	6	6	6	6	6
○	7	7	7	7	7	7
○	8	8	8	8	8	8
○	9	9	9	9	9	9

To answer $.75$ in a question, fill in the answer grid as shown below.

.	7	5				
○						
○	○	○	○	○	○	○
○	1	1	1	1	1	1
○	2	2	2	2	2	2
○	3	3	3	3	3	3
○	4	4	4	4	4	4
○	5	5	●	5	5	5
○	6	6	6	6	6	6
○	7	●	7	7	7	7
○	8	8	8	8	8	8
○	9	9	9	9	9	9

1 What is the value of $63,798 \div 49$?

- A 132
- B 1,302
- C 1,320
- D 1,506

2 What is the value of the following expression?

$$\frac{9^2 + 5 \cdot 2 - 1^3}{2^4 - 6}$$

Enter your answer in the space provided.

3 Points A , B , C and D are plotted on the number line shown.

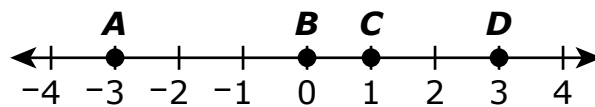

Which point represents the value of $|3|$?

- A point A
- B point B
- C point C
- D point D

4 All of the numbers that do not exceed 15 will be graphed on a number line.

Which statement best describes the graph of the numbers?

Select one answer.

- A** The graph will be a ray that starts at 14 and points to the left. The graph will include the endpoint of the ray.
- B** The graph will be a ray that starts at 15 and points to the left. The graph will include the endpoint of the ray.
- C** The graph will be a ray that starts at 15 and points to the right. The graph will not include the endpoint of the ray.
- D** The graph will be a ray that starts at 16 and points to the left. The graph will not include the endpoint of the ray.

5 What is the value of $25.761 - 17.49$?

- A** 8.271
- B** 8.371
- C** 8.712
- D** 24.012

- 6 Melvin and Roberto played football on two different teams last season.
- Melvin's team won w games.
 - Roberto's team won 3 fewer games than Melvin's team.

Which expression can be used to represent the number of games Roberto's team won last season?

Select one answer.

- A** $w + 3$
- B** $w - 3$
- C** $w \cdot 3$
- D** $w \div 3$
- 7 A jar contains some marbles that are either white or red. The ratio of the number of white marbles to the number of red marbles is 2 : 3.
- What might be the total amount of white and red marbles in the jar?
- Select **all** that apply.
- A** 6 white marbles and 9 red marbles
- B** 12 white marbles and 13 red marbles
- C** 14 white marbles and 21 red marbles
- D** 22 white marbles and 33 red marbles
- E** 36 white marbles and 39 red marbles

8 An artist is creating several pieces of pottery.

- He has $10\frac{4}{5}$ pounds of clay.
- He will use $\frac{7}{10}$ of a pound to create each piece of pottery.

What is the **greatest** number of pieces of pottery the artist can make with this clay?

- A The artist can create 3 pieces of pottery.
- B The artist can create 5 pieces of pottery.
- C The artist can create 12 pieces of pottery.
- D The artist can create 15 pieces of pottery.

9 An expression is shown.

$$56 + 91$$

Which expression is equivalent to the given expression **and** is written using the **greatest** common factor of the two numbers in the expression?

- A $1(56 + 91)$
- B $3(14 + 27)$
- C $7(8 + 13)$
- D $13(4 + 7)$

10 Which expressions are equivalent to $4x + 16$?

Select **all** that apply.

A $2x + 2x + 8 + 8$

B $2x(2 + 8)$

C $4x + 4x + 4x + 4x$

D $4(x + 4)$

E $4x(1 + 4)$

11 Describe how the numbers $-7\frac{1}{2}$ and -7 would be positioned relative to each other on a horizontal number line.

Select one answer.

A The number $-7\frac{1}{2}$ would be positioned to the left of -7 on a horizontal number line because $-7\frac{1}{2} < -7$.

B The number $-7\frac{1}{2}$ would be positioned to the left of -7 on a horizontal number line because $-7\frac{1}{2} > -7$.

C The number $-7\frac{1}{2}$ would be positioned to the right of -7 on a horizontal number line because $-7\frac{1}{2} < -7$.

D The number $-7\frac{1}{2}$ would be positioned to the right of -7 on a horizontal number line because $-7\frac{1}{2} > -7$.

- 12** Point A is located at $(6, 3)$ in the coordinate plane. Point B is located 5 units below point A .

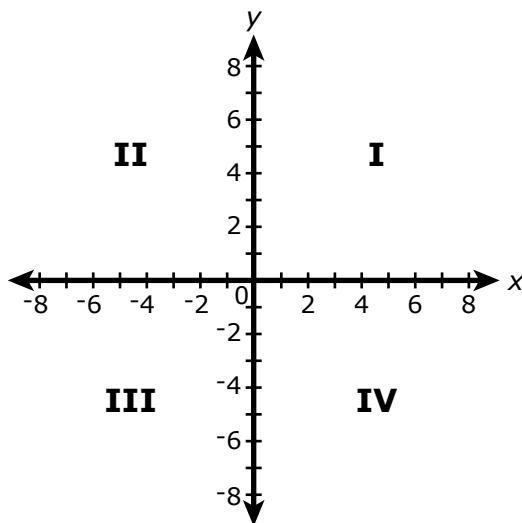

Which quadrant in the coordinate plane contains point B ?

- A** quadrant I
- B** quadrant II
- C** quadrant III
- D** quadrant IV

13 Which of the following histograms shows a distribution that is skewed to the left?

Select one answer.

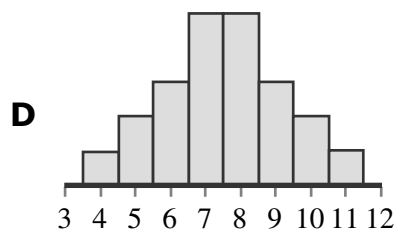
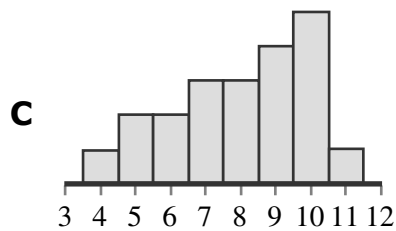
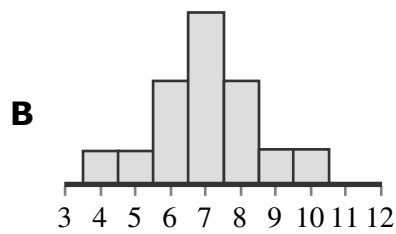
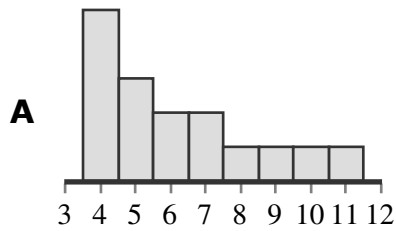

14 What is the value of 43.7×0.25 ?

A 1.0925

B 4.395

C 10.925

D 43.95



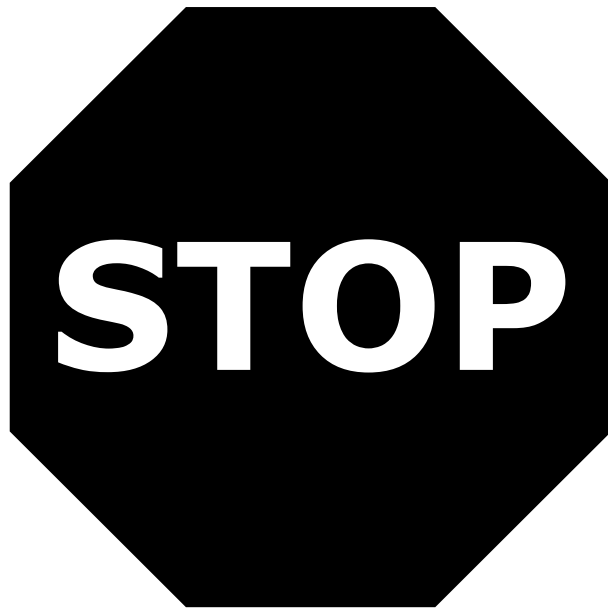

You have come to the end of Section 1 of the test. Review your answers from Section 1 only.





GO ON TO NEXT PAGE



Section 2 (Calculator)

Directions:

Today, you will take Section 2 of the Grade 6 Mathematics Practice Test. You will be able to use a calculator.

Read each question. Then, follow the directions to answer each question. Mark your answers by completely filling in the circles in your answer document. Do not make any pencil marks outside of the circles. If you need to change an answer, be sure to erase your first answer completely. If a question asks you to show or explain your work, you must do so to receive full credit. Only responses entered within the space provided will be scored.

If you do not know the answer to a question, you may go on to the next question. If you finish early, you may review your answers and any questions you did not answer in this section ONLY. Do not go past the stop sign.



Directions for Completing the Answer Grids

1. Work the problem and find an answer.
2. Write your answer in the boxes at the top of the grid.
3. Print only one number or symbol in each box. Do not leave a blank box in the middle of an answer.
4. Under each box, fill in the circle that matches the number or symbol you wrote above. Make a solid mark that completely fills the circle.
5. Do not fill in a circle under an unused box.
6. Fractions cannot be entered into an answer grid and will not be scored. Enter fractions as decimals.
7. See below for examples on how to correctly complete an answer grid.

EXAMPLES

To answer -3 in a question, fill in the answer grid as shown below.

-	3					
●						
○	○	○	○	○	○	○
○	1	1	1	1	1	1
○	2	2	2	2	2	2
●	3	3	3	3	3	3
○	4	4	4	4	4	4
○	5	5	5	5	5	5
○	6	6	6	6	6	6
○	7	7	7	7	7	7
○	8	8	8	8	8	8
○	9	9	9	9	9	9

To answer $.75$ in a question, fill in the answer grid as shown below.

	.	7	5			
○						
●	○	○	○	○	○	○
○	1	1	1	1	1	1
○	2	2	2	2	2	2
○	3	3	3	3	3	3
○	4	4	4	4	4	4
○	5	5	●	5	5	5
○	6	6	6	6	6	6
○	7	●	7	7	7	7
○	8	8	8	8	8	8
○	9	9	9	9	9	9



- 1 Which value from the set $\left\{\frac{3}{4}, 1, \frac{3}{2}, 3\frac{3}{4}\right\}$ is a solution to the equation

$$x + \frac{3}{2} = 2\frac{1}{4}?$$

- A $\frac{3}{4}$
- B 1
- C $\frac{3}{2}$
- D $3\frac{3}{4}$

- 2 Kevin has a rectangular prism that was made up of identical cubes, with no gaps between any cubes. The following figure shows the prism and one of the cubes.

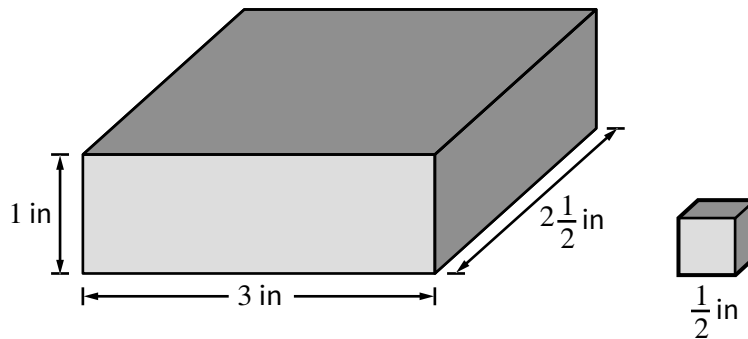

What was the total number of the cubes used to make up the prism?
Enter your answer in the space provided.



- 3** A baker made 8 pounds of cookie dough. The baker used the dough to make several batches of cookies. The graph shows the amount of cookie dough that is needed to make different numbers of batches of cookies.

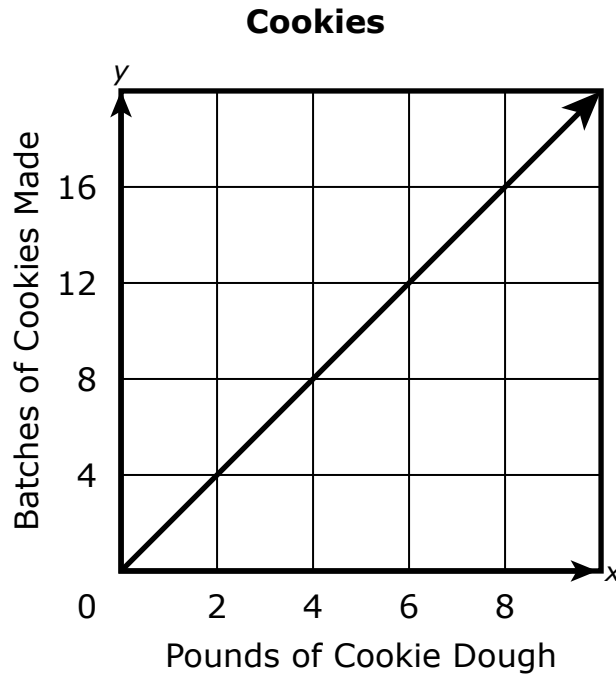

Based on the graph, which statement correctly explains the number of batches of cookies the baker can make from the 8 pounds of dough?

- A** The baker can make 8 batches of cookies because it takes 1 pound of dough to make 1 batch of cookies.
- B** The baker can make 16 batches of cookies because it takes 1 pound of dough to make 1 batch of cookies.
- C** The baker can make 8 batches of cookies because it takes 1 pound of dough to make 2 batches of cookies.
- D** The baker can make 16 batches of cookies because it takes 1 pound of dough to make 2 batches of cookies.



- 4 A machine in a factory makes chairs at a rate of 2 chairs every 10 minutes.
- How much time does the machine take to make 5 chairs?
 - How many minutes would it take for the factory to fulfill an order for 32 chairs?

Show your work or explain how you determined your answers.

Enter your answers and your work or explanation in the space provided.

- 5 A worker has 25 feet of ribbon to make bows. Each bow uses 2 feet of ribbon. The worker divides 25 by 2 and gets 12.5 as an answer.

What does the worker's answer mean in this context?

- A The worker can make 12 bows and have 1 foot of ribbon left.
- B The worker can make 12 bows and have 5 feet of ribbon left.
- C The worker can make 5 bows and have 12 feet of ribbon left.
- D The worker can make 1 bow and have 12 feet of ribbon left.



- 6 The numbers $-\frac{1}{2}$ and $\frac{2}{5}$ are graphed on the number line.

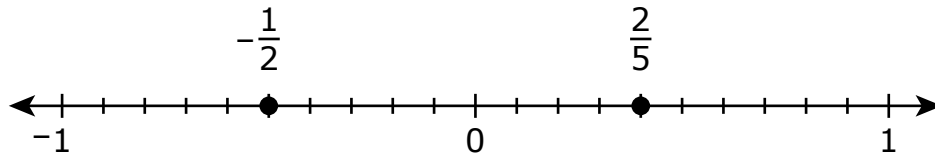

Which statement correctly compares the absolute values of $-\frac{1}{2}$ and $\frac{2}{5}$ and gives the correct reasoning for the comparison?

- A $-\frac{1}{2}$ has the lesser absolute value because $-\frac{1}{2}$ is closer to zero than $\frac{2}{5}$ is to zero.
 - B $-\frac{1}{2}$ has the greater absolute value because $-\frac{1}{2}$ is closer to zero than $\frac{2}{5}$ is to zero.
 - C $-\frac{1}{2}$ has the lesser absolute value because $-\frac{1}{2}$ is further from zero than $\frac{2}{5}$ is from zero.
 - D $-\frac{1}{2}$ has the greater absolute value because $-\frac{1}{2}$ is further from zero than $\frac{2}{5}$ is from zero.
- 7 At a store, 40% of all the refrigerators are silver. There are 50 silver refrigerators at the store.

How many refrigerators are at the store?

Enter your answer in the space provided.



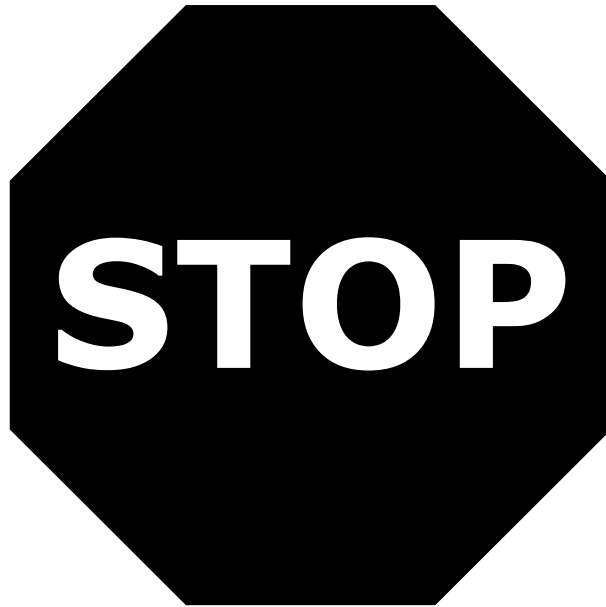

You have come to the end of Section 2 of the test. Review your answers from Section 2 only.





GO ON TO NEXT PAGE



Section 3 (Calculator)

Directions:

Today, you will take Section 3 of the Grade 6 Mathematics Practice Test. You will be able to use a calculator.

Read each question. Then, follow the directions to answer each question. Mark your answers by completely filling in the circles in your answer document. Do not make any pencil marks outside of the circles. If you need to change an answer, be sure to erase your first answer completely. If a question asks you to show or explain your work, you must do so to receive full credit. Only responses entered within the space provided will be scored.

If you do not know the answer to a question, you may go on to the next question. If you finish early, you may review your answers and any questions you did not answer in this section ONLY. Do not go past the stop sign.



Directions for Completing the Answer Grids

1. Work the problem and find an answer.
2. Write your answer in the boxes at the top of the grid.
3. Print only one number or symbol in each box. Do not leave a blank box in the middle of an answer.
4. Under each box, fill in the circle that matches the number or symbol you wrote above. Make a solid mark that completely fills the circle.
5. Do not fill in a circle under an unused box.
6. Fractions cannot be entered into an answer grid and will not be scored. Enter fractions as decimals.
7. See below for examples on how to correctly complete an answer grid.

EXAMPLES

To answer -3 in a question, fill in the answer grid as shown below.

-	3					
●						
○	○	○	○	○	○	○
○	1	1	1	1	1	1
○	2	2	2	2	2	2
●	3	3	3	3	3	3
○	4	4	4	4	4	4
○	5	5	5	5	5	5
○	6	6	6	6	6	6
○	7	7	7	7	7	7
○	8	8	8	8	8	8
○	9	9	9	9	9	9

To answer $.75$ in a question, fill in the answer grid as shown below.

	.	7	5			
○						
●	○	○	○	○	○	○
○	1	1	1	1	1	1
○	2	2	2	2	2	2
○	3	3	3	3	3	3
○	4	4	4	4	4	4
○	5	5	●	5	5	5
○	6	6	6	6	6	6
○	7	●	7	7	7	7
○	8	8	8	8	8	8
○	9	9	9	9	9	9



Mathematics

- 1 Laura uses 3 yards of fabric to make 2 skirts. She uses the same amount of fabric to make each skirt.

At this rate, what is the total amount of fabric, in yards, she needs to make 6 skirts?

Select one answer.

- A 4
- B 6
- C 7
- D 9



- 2 Packages of bottled water are purchased for a sixth-grade picnic. Each package contains 24 water bottles.

Which graph models the relationship between x , the number of packages of bottled water purchased, and y , the number of water bottles?

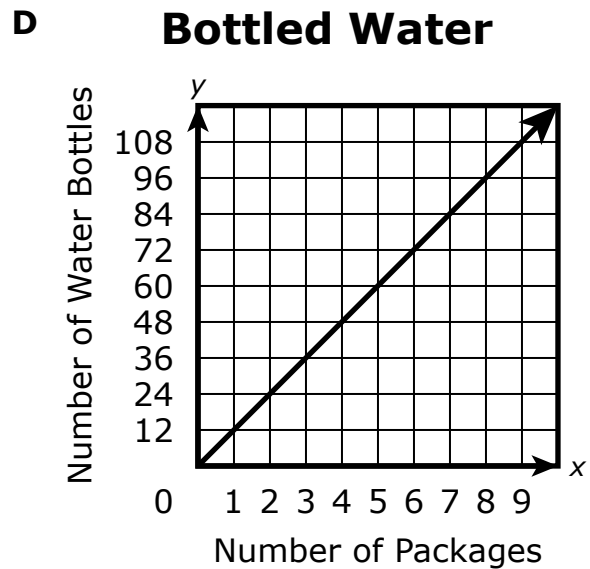
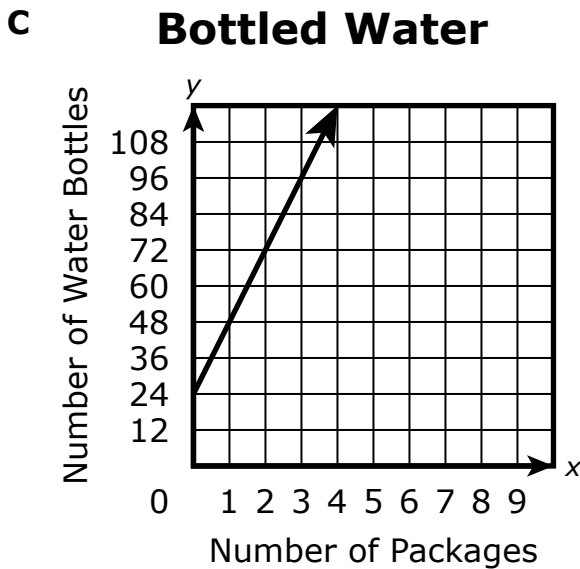
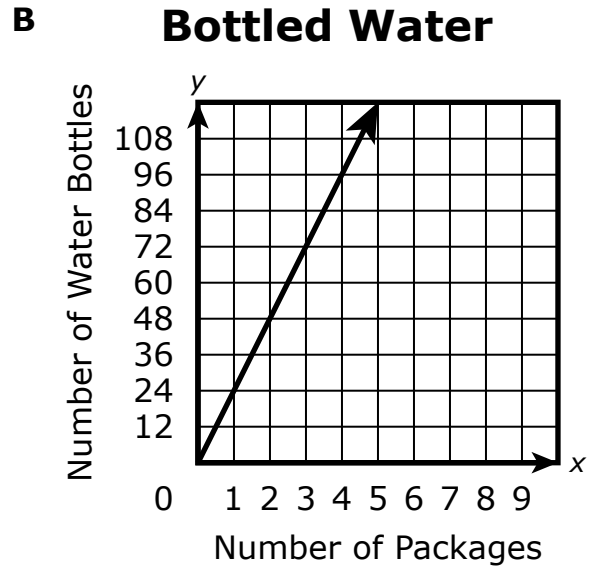
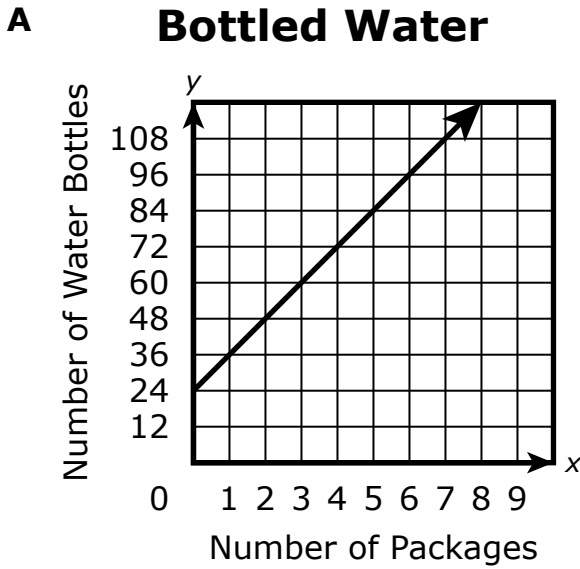



- 3 The diagram shows the net of a wooden chest in the shape of a rectangular prism. All dimensions are in feet.

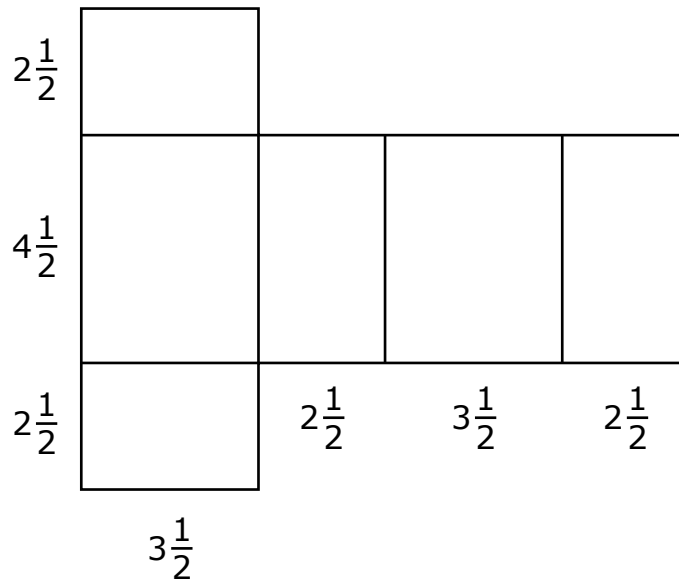

A painter will apply stain to all the faces of the wooden chest. The calculations that the painter used to find the surface area, in square feet, of the wooden chest are shown.

$$2\frac{1}{2} \times 3\frac{1}{2} = \left(2 \times 3\right) + \left(\frac{1}{2} \times \frac{1}{2}\right) = 6\frac{1}{4} \times 2 = 12\frac{1}{2}$$

$$2\frac{1}{2} \times 4\frac{1}{2} = \left(2 \times 4\right) + \left(\frac{1}{2} \times \frac{1}{2}\right) = 8\frac{1}{4} \times 2 = 16\frac{1}{2}$$

$$3\frac{1}{2} \times 4\frac{1}{2} = \left(3 \times 4\right) + \left(\frac{1}{2} \times \frac{1}{2}\right) = 12\frac{1}{4} \times 2 = 24\frac{1}{2}$$

The total surface area is $12\frac{1}{2} + 16\frac{1}{2} + 24\frac{1}{2} = 53\frac{1}{2}$ square feet.

- What mistake was made in the calculation of the surface area of the wooden chest?
- Find the correct surface area of the wooden chest.

Enter your answers and your work or explanation in the space provided.



- 4 The expression $12x + 8$ is equivalent to the expression $a(bx + c)$, where b and c are constants and have no common factors. A student wrote the answer as $2(6x + 4)$.

Which statement **best** explains whether the student's answer is correct or incorrect?

- A** The student's answer is incorrect because the greatest common factor of $12x$ and 8 is $2x$, so the correct expression is $2x(6x + 4)$.
- B** The student's answer is incorrect because the greatest common factor of $12x$ and 8 is $4x$, so the correct expression is $4x(3x + 2)$.
- C** The student's answer is incorrect because the greatest common factor of $12x$ and 8 is 4 , so the correct expression is $4(3x + 2)$.
- D** The student's answer is incorrect because the greatest common factor of $12x$ and 8 is 8 , so the correct expression is $8(4x + 1)$.
- 5 An art teacher has a jar containing $\frac{3}{4}$ pound of glitter for use by the students in a class. The glitter is being separated into portions that are each $\frac{1}{10}$ pound of glitter.

The teacher asked, "What is the greatest number of whole portions that can be made?"

One student incorrectly obtains the answer of $\frac{4}{3} \times \frac{10}{1} = \frac{40}{3} = 13\frac{1}{3}$, and says 13 portions can be made.

- Explain the mistake that was made in the calculations.
- What is the correct answer to the question?

Enter your answers and your work or explanation in the space provided.



Mathematics

- 6 Students in a science class measured rain by writing down the depth of water in a bucket that collected the rain. The bucket was empty before the rain began to fall at a steady rate over a 6-hour period during school. After 3 hours, the water had a depth of 18 millimeters.

At what average unit rate, in millimeters per hour, did the bucket fill after rain started to fall at a steady rate?

A $\frac{1}{6}$

B $\frac{1}{3}$

C 3

D 6



7 The following histogram summarizes the recorded number of push-ups that a group of fitness instructors completed in a certain time period. Each interval contains possible values at the left endpoint up to but not including the right endpoint.

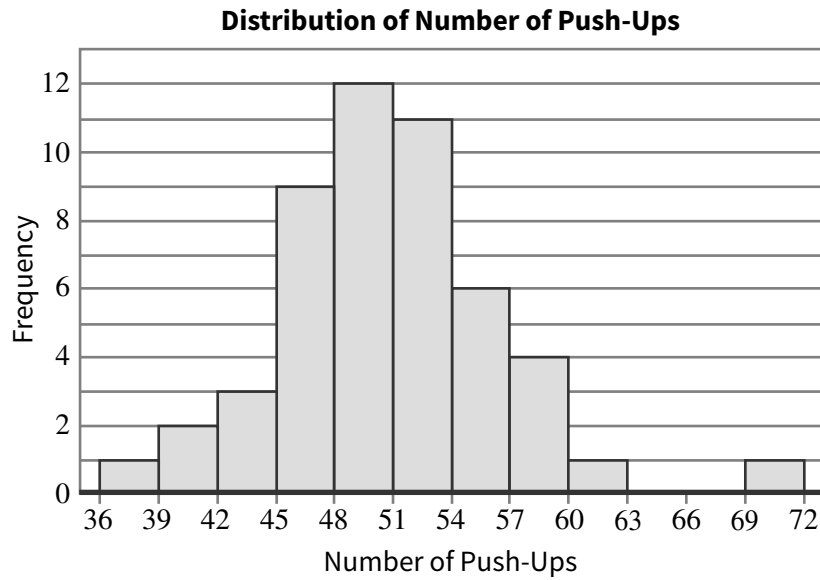

What is the total number of fitness instructors represented in the histogram who completed 57 or more push-ups?

Enter your answer in the space provided.



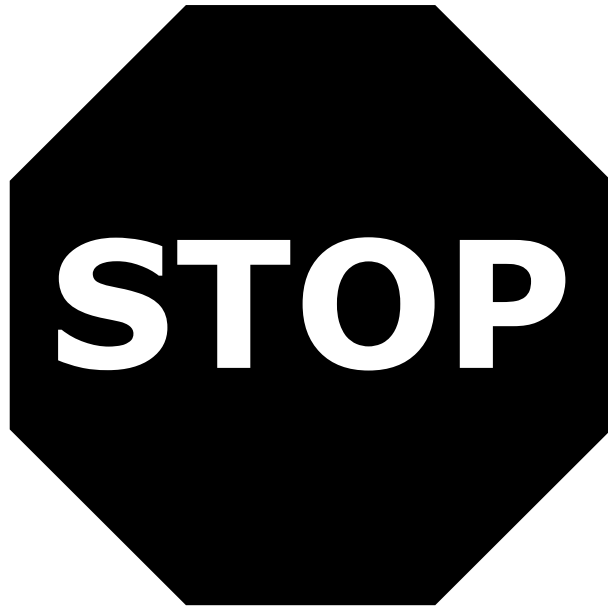

You have come to the end of Section 3 of the test. Review your answers from Section 3 only.





GO ON TO NEXT PAGE



Section 4 (Calculator)

Directions:

Today, you will take Section 4 of the Grade 6 Mathematics Practice Test. You will be able to use a calculator.

Read each question. Then, follow the directions to answer each question. Mark your answers by completely filling in the circles in your answer document. Do not make any pencil marks outside of the circles. If you need to change an answer, be sure to erase your first answer completely. If a question asks you to show or explain your work, you must do so to receive full credit. Only responses entered within the space provided will be scored.

If you do not know the answer to a question, you may go on to the next question. If you finish early, you may review your answers and any questions you did not answer in this section ONLY. Do not go past the stop sign.



Directions for Completing the Answer Grids

1. Work the problem and find an answer.
2. Write your answer in the boxes at the top of the grid.
3. Print only one number or symbol in each box. Do not leave a blank box in the middle of an answer.
4. Under each box, fill in the circle that matches the number or symbol you wrote above. Make a solid mark that completely fills the circle.
5. Do not fill in a circle under an unused box.
6. Fractions cannot be entered into an answer grid and will not be scored. Enter fractions as decimals.
7. See below for examples on how to correctly complete an answer grid.

EXAMPLES

To answer -3 in a question, fill in the answer grid as shown below.

-	3					
●						
○	○	○	○	○	○	○
○	1	1	1	1	1	1
○	2	2	2	2	2	2
●	3	3	3	3	3	3
○	4	4	4	4	4	4
○	5	5	5	5	5	5
○	6	6	6	6	6	6
○	7	7	7	7	7	7
○	8	8	8	8	8	8
○	9	9	9	9	9	9

To answer $.75$ in a question, fill in the answer grid as shown below.

	.	7	5			
○						
●	○	○	○	○	○	○
○	1	1	1	1	1	1
○	2	2	2	2	2	2
○	3	3	3	3	3	3
○	4	4	4	4	4	4
○	5	5	●	5	5	5
○	6	6	6	6	6	6
○	7	●	7	7	7	7
○	8	8	8	8	8	8
○	9	9	9	9	9	9



Mathematics

- 1 Yvonne's age, in years, is represented by y . Rebekah's age is one year less than three times Yvonne's age.

Which expression represents Rebekah's age, in years?

Select one answer.

- A $3y - 1$
- B $1 - 3y$
- C $3(y - 1)$
- D $3(1 - y)$



- 2 Point K is located at $(1, 2)$ on the following coordinate plane. A square that has a perimeter of 20 units will be drawn so that K is one vertex of the square.

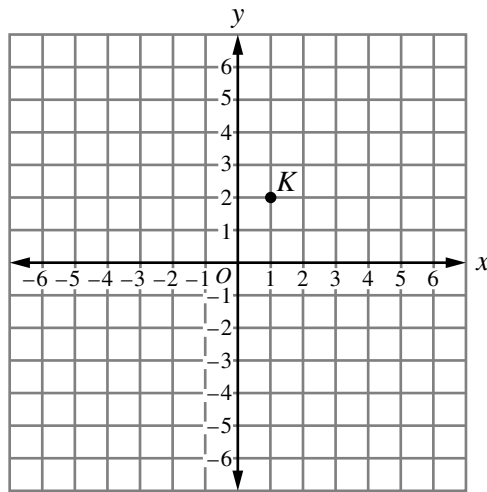

Which **three** ordered pairs could represent the location of another vertex of the square?

Select the **three** correct answers.

- A $(-4, 2)$
- B $(1, -3)$
- C $(1, 6)$
- D $(4, 2)$
- E $(6, 2)$



3 The table shows several values of x and y .

x	y
1	6
3	8
4	9

A student claims that since each value for y is 5 more than the corresponding value of x , that the ratio of y to x is 5 to 1 for the values in the tables.

Which statement **best** explains whether the student's claim is correct or incorrect?

- A The student's claim is correct because $6 - 1 = 5$, $8 - 3 = 5$, and $9 - 4 = 5$.
- B The student's claim is incorrect because the ratio of y to x is different for each pair of corresponding x - and y -values.
- C The student's claim is incorrect because the ratio of y to x is 1 to 5 for each pair of corresponding x - and y -values.
- D The student's claim is incorrect because the ratio between the x -values and the y -values of the first two points is 2 to 1 and not 5 to 1.



- 4 Many frames are being made to hold a number of paintings that all have a width of 18 inches. The wood being used to make the frames is 2 inches wide.

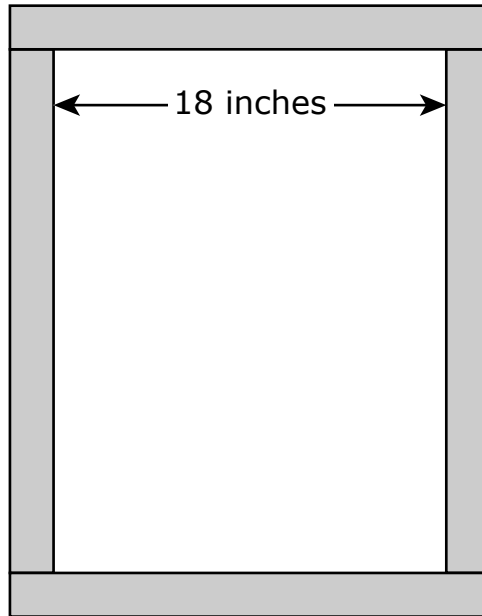

- If the height of one of the paintings was 24 inches, what is the total length, in inches, of 2-inch wood that would be needed to make the frame? Show your work and your calculations.
- What is the number of square inches of wood that a frame would have if the painting had a height of 36 inches?

Enter your answer and your work in the space provided.



5 The equation $x + 5 = 12$ can be solved using one step.

Which statement provides a correct explanation and solution to the equation?

- A The number 5 should be added to both sides of the equation, and the solution is $x = 17$.
- B The number 5 should be subtracted from both sides of the equation, and the solution is $x = 7$.
- C The number 5 should be divided from both sides of the equation, and the solution is $x = \frac{12}{5}$.
- D The number 5 should be multiplied to both sides of the equation, and the solution is $x = 60$.

6 A machine at a company makes toy cars at a constant rate. The company received an order for toy cars that exceeded the number of toy cars that the company had in stock.

Which **three** pieces of information are needed to determine the amount of time it will take the machine to make enough additional toy cars to fill the order?

Select the **three** pieces of information that are needed.

- A the cost to make each toy car
- B the rate that the machine makes toy cars
- C the number of toy cars requested in the order
- D the number of people needed to run the machine
- E the number of toy cars available when the order was received



- 7 A game designer used 9 ounces of clay to make 24 identical pieces for a game.

What is the number of ounces of clay that were used for each piece?

A $\frac{3}{8}$

B $\frac{5}{8}$

C $\frac{8}{5}$

D $\frac{8}{3}$



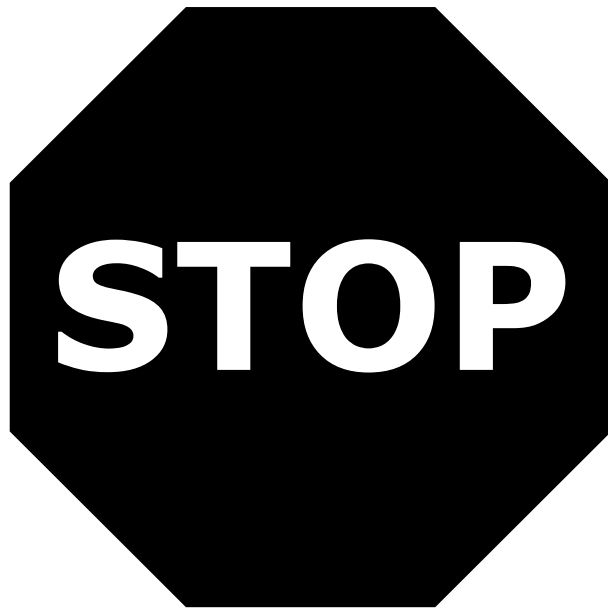

You have come to the end of Section 4 of the test. Review your answers from Section 4 only.



6-MATH