



## *Customer Guide for Electric Service – PA*

*September 2021*

(Page Intentionally Blank)

## TABLE OF CONTENTS

1.0	INTRODUCTION .....	7
2.0	DEFINITIONS .....	8
3.0	GENERAL INFORMATION .....	11
3.1	Availability & Character of Service .....	11
3.2	Application for Service.....	12
3.3	Line Extensions .....	13
3.4	Number of Services & Meters.....	13
3.5	Use of Service by the Customer .....	14
3.6	Interruption & Liability .....	15
3.7	Final Connections.....	15
3.8	Grounding/Bonding.....	15
3.9	Electrical Inspection .....	15
3.10	Meter & Seal Tampering.....	16
3.11	Meter Attachments .....	16
3.12	Disconnect/Reconnect of Existing Service (Upgrades/Maintenance) .....	17
3.13	Locating Underground Electric Facilities.....	17
3.14	Required Clearance from Markout for Digging in the Vicinity of Company Underground Electric Facilities.....	17
3.15	Buildings/Structures & Swimming Pools/Spas/Hot Tubs near Electric Lines .....	17
3.16	Attachments on Company-Owned Facilities .....	18
3.17	Clearance of Trees from Power Lines .....	18
3.18	Access to Customer's Premises .....	18
3.19	Company's Equipment on Customer's Premises.....	19
3.20	Requested Protection for Persons Working Near Company Facilities .....	19
4.0	TEMPORARY SERVICE .....	19
5.0	PERMANENT SERVICE – OVERHEAD .....	19
5.1	General .....	19
5.2	Service Drop Clearances .....	20
5.3	Mobile Homes or Mobile Home Parks.....	20
5.4	Travel Trailer or RV Parks .....	21
5.5	Central Pole Distribution Metering Service .....	21
6.0	PERMANENT SERVICE – UNDERGROUND .....	21
6.1	General .....	21
6.2	Underground Services from Overhead Lines .....	22
6.3	Underground Services in Underground Residential Areas.....	22
6.4	Underground Services in Underground Commercial Areas .....	23
6.5	Underground Services in Central Business District Network Areas .....	23
6.6	Transformer Foundations & Vaults .....	23
6.7	Mobile Homes or Mobile Home Parks .....	24
7.0	METER INSTALLATIONS .....	24
7.1	General .....	24
7.2	Meter Locations.....	25
7.3	Group Meter Installations.....	26
7.4	Meter Relocations.....	26
7.5	Minimum Meter Sockets Requirements .....	26
7.6	Metering Equipment Installation Guideline Summary.....	29
7.7	Minimum Size Meter Socket - 480-Volt Services.....	29
7.8	Installations Requiring 400 Amperes & Less of Continuous Load Current .....	30
7.9	Installations Requiring Over 400 Amperes of Continuous Load Current.....	30
7.10	Approved Current Transformer Cabinets .....	30
7.11	Service at Voltages Greater Than 600 Volts .....	33
7.12	Disconnect Requirements.....	33
8.0	CUSTOMER EQUIPMENT.....	33
8.1	Motors (Inrush Limitations & Motor Protection).....	33
8.2	Power Factor.....	36
8.3	Welders & Industrial Furnaces .....	36

8.4	Electrical Cooking, Space Heating, Water Heating, Ice / Snow Melting, & Electric Vehicle Charging.....	36
8.5	Low-Voltage Surge Arresters (600 Volts or Less) .....	36
8.6	UPS, Cogeneration, Back-up Generation, & Interconnected Generation.....	36
8.7	Harmonic Producing Equipment .....	37
8.8	Protective Devices.....	37
8.9	Special Equipment.....	37

**EXHIBITS**

Service Material Guideline for Pennsylvania Operating Companies (2 pages) ..... Exhibit 1

OH Service Drop Clearances Minimum for Services Under 600 Volts ..... Exhibit 2

Typical Temporary Service Overhead Installation ..... Exhibit 3

Typical Temporary Service Underground Installation ..... Exhibit 4

Typical Customer Grounding Details ..... Exhibit 5

Typical Overhead Single-phase Service Entrance Installation 400 Amp or Less ..... Exhibit 6

Overhead Service Typical Service Drop Attachment..... Exhibit 7

Typical Single-Phase Underground Service Lateral Installation 400 Amp or Less (PA) ..... Exhibit 8

Direct Attachment of Customer-Owned Underground Service Lateral(s) on Pennsylvania  
Operating Company's Poles ..... Exhibit 9

Standoff Attachment of Customer Underground Service Lateral(s) on Pennsylvania Operating  
Company's Poles ..... Exhibit 10A

Customer-Owned Underground Secondary Cable to Handhole/Pedestal ..... Exhibit 10B

Typical Overhead Service Central Distribution Installation ..... Exhibit 11

Typical Underground Service Central Distribution Installation / Stand-Alone Metering ..... Exhibit 12

Typical Single Mobile Home Service Overhead & Underground ..... Exhibit 13

Metering & Service Facilities for Mobile Homes & Travel Trailer Parks Four or More Meters ..... Exhibit 14

Metering Installation Single-Phase & Three-Phase 480-Volt Self-Contained Meter with Source-Side  
Disconnect 400 Amp or Less..... Exhibit 15

Multiple Metering Installation Self-Contained Metering 400 Amp or Less..... Exhibit 16

Metering Installation Self-Contained Single-Phase 400 Amp or Less..... Exhibit 17

Metering Installation Self-Contained Three-Phase 400 Amp or Less ..... Exhibit 18

Metering Installation Outdoor - Metering Cabinet with Current Transformers Details..... Exhibit 19

Metering Installation Outdoor Current Transformer Cabinet Mounted on a Building ..... Exhibit 20

Underground Secondary Service in Pad-Mounted Transformer with Current Transformers ..... Exhibit 21

Minimum Clearances from Structures for Oil-Filled Pad-Mounted Equipment..... Exhibit 22

Clearances of Pad-Mounted Equipment, Pedestals, Handholes, or Manholes from Shrubs, Plants,  
Fences, Wall Screenings, & Other Obstructions ..... Exhibit 23

Trench, Conduit, & Backfill Requirements (4 pages)..... Exhibit 24

Three-Phase Transformer Pre-Cast Concrete Foundation / Vault (4 pages) ..... Exhibit 25

Concrete Flat-Pad Foundation Pad-Mounted Transformer 75 to 500 kVA Three-Phase, 34.5 kV &  
Below High-Side ..... Exhibit 26

Concrete Flat-Pad Foundation Pad-Mounted Transformer 750 to 2500 kVA Three-Phase, 34.5 kV  
& Below High-Side ..... Exhibit 27

Concrete Flat-Pad Foundation Pad-Mounted Transformer General Notes..... Exhibit 28

Typical Single-Phase Box Pad Foundation Installation (1Φ Transformer or 1Φ Junction) ..... Exhibit 29

Vehicular Barrier for Pad-Mounted Equipment & Poles..... Exhibit 30

Typical Underground Service Traffic Signal, CATV, or Communication Stand-Alone Equipment..... Exhibit 31

**APPENDIX**

Fax Application Builder Install Request Form 1046 ..... Appendix 1

## SUMMARY OF SIGNIFICANT CHANGES TO THIS GUIDE

(August 2021)

This document supersedes the FirstEnergy “*Customer Guide for Electrical Service - PA*” document dated July 2015.

Significant changes to the text from the last published version are identified in this document by a vertical bar in the left-hand margin (refer to the example in the left-hand margin of this paragraph). Additionally, significant changes to the text (listed by section) and to the exhibits (listed by exhibit number) are summarized in the table below:

Section	Changes
1.0	Revised paragraph on the steps to access the on-line version of this document.
2.0 (Definitions)	Added new definitions for <i>Authority Having Jurisdiction, Customer Guide for Electric Service, Developer, Power Factor, Private Right-of-Way, Qualified Person, and Voltage Transformers</i> . Revised the definitions of <i>Distribution Lines, FAA, Final Grade, Mobile Home, Select Backfill, Tariff, and Temporary Service</i> .
3.2	Added lead-time for a large underground development (> 20 lots).
3.5	Added paragraph: for a customer-owned and installed underground service lateral, if a customer increases the service lateral length or load, the customer shall be responsible to verify that ampacity, voltage drop, and voltage flicker limitations are suitable to serve the load.
3.8	Added the requirement for customer-owned three-phase laterals, not to install a fifth grounding conductor into the pad-mounted transformer or current transformer cabinet.
3.11	Added a list of unauthorized attachments to Company-owned meters and meter circuits.
3.13	1 <sup>st</sup> paragraph: Added requirement to notify the One-Call locating company when driving ground rods. 2 <sup>nd</sup> paragraph: Added marking requirements for new electrical facilities.
3.15	1 <sup>st</sup> paragraph: Add text: poles attachment prohibited without approval from Company. 2 <sup>nd</sup> paragraph: Removed text: “without written approval from Company.” for pools
3.18	3 <sup>rd</sup> paragraph: Add the following text, “Company personnel are not permitted to climb onto the customer’s roof. Therefore, all connections and other Company work shall be accessible from a ladder or bucket truck”
6.1	Revised UG Riser requirements. Added customer shall coordinate the installation with the Company.
6.4	Moved this paragraph to the first paragraph in Section 6.4.
7.1	Removed first bulleted item from list. Added 3 paragraph: When emergency disconnects are required by the NEC, they shall be located on the load-side of the metering.
7.5	Added new bulleted item: “ <i>Socket components and connection points shall be designed, located, and adequate space provided, such that the use of horn bypass jumpers, service savers, cable pullers, and other standard electric restoration and maintenance equipment can be safely and effectively utilized by the utility.</i> ” Added 2 <sup>nd</sup> bullet under “Residential Single-Phase,;” Lever by-pass with jaw tension release is also acceptable.” Revised meter socket requirements. Consolidated information into new table of Meter Socket Requirements.
7.8	Added paragraph the requirement that services less 400 amps be self-contained metering and evaluated when service is changed or upgraded.
7.9	Added the requirement to consult the Company before beginning any installation requiring instrument transformers. Removed requirement for telephone service.

Section	Changes
7.10	1 <sup>st</sup> paragraph: added “. No unmetered conductors are permitted within the CT enclosure cabinet.” Updated approved current transformer table. Revised short-current interrupting rating to 85,000 amps for the Erickson Electrical CT cabinets. Added footnote in table permitting East Coast Panelboard CTJ-800-A.
8.4	Added Electric Vehicle Charging.
Exhibit	Changes
1	Updated Company/Customer requirements. Added limit of the number of cables in Note 2. Removed Met-Ed requirement for customer to pick-up UG service wire at line shop prior to installing conduit. Added requirement that customer supplies and installs all UG conduit. Removed telephone line requirement.
2	Added clearances for services above decks and railings plus other minor changes.
3	Added structure shall be accessible from a bucket truck. Added through bolts required for attaching equipment to pole. Minor revisions to drawing. Remove old Note 8 (external ground rods) then renumber Notes.
4	Added through bolts required for attaching equipment to pole. Remove old Note 8 (external ground rods) then renumber Notes.
6	Revised Note 2. Connections shall be accessible from a ladder. Company personnel are not permitted to climb on customer’s roof.
8	Moved the slip-joint to below the top clamp on drawing. Removed reference to direct-buried cable. Remove old Note 4 (external ground rods) then renumber Notes.
9	Revised drawing to only show work required by customer. Revised Note 5 and added Note 6. Customer shall contact the Company before installing. If required per Exhibit 1, customer supplies the electrical-grade conduit, brackets/clamps, weatherhead, and cable coiled on pole. Company will install any facilities on the Company-owned pole.
10A	Renamed Exhibit 10 to 10A. Revised drawing and Note 5. If required per Exhibit 1, customer supplies the electrical-grade conduit, brackets/clamps, weatherhead(s), and cable coiled at bottom of pole. Company will install any facilities on the Company-owned pole. Conduit brackets shall not extend more than an inch from conduit.
10B	New Exhibit. The use of this Exhibit requires Company approval. This Exhibit to be used for installation of a handhole or pedestal for connection of the customer’s service lateral at base of pole.
11	Added that the pole shall be new when installed. Removed CT option from drawing.
12	Revised minimum size support posts to 2 ½ inch. Added ground movement protection. Replace Note 5 (external ground rods) and add Note 6. Retitled the Exhibit.
13	Added that the pole shall be new when installed. Revised minimum size of support posts to 2 ½ inch. Added ground movement protection. Remove old Note 9 (external ground rods), renumber Notes, then add a new Note 11.
14	Added that the pole shall be new when installed. Revised minimum size of support posts to 2 ½ inch. Added ground movement protection. Remove old Note 6 (external ground rods), renumber Notes, then add a new Note 10.
17	Revised and added drawings of common 1ϕ self-contained meter sockets. Replace Note 4.
18	Revised the drawings including extensive revision all the Notes.
19	Revised drawing to better show the current transformer configuration and wiring. Remove old Note 7 (telephone link requirement), renumber Notes, then add a new Note 10. Note 10 – Do not run a separate grounding conductor from current transformer cabinet to main disconnect. Removed telephone link requirement.

Exhibit	Changes
20	Remove old Note 4 (telephone link requirement), renumber Notes, then revised Note 6.
21	Revised minimum size support posts to 2 ½ inch. Remove old Note 9 (telephone link requirement), renumber Notes.
22	Move old Note 9 to Note 1 and renumber Notes. Added decks and steps to Note 3. Added “at mature growth” to Note 8. Added Note 10. Added an asterisked note to Table 1
24	Added more detail to drawing. Removed references to direct buried cables on drawing. Notes were revised and expanded.
25	Minor revisions to drawing. Expanded Pre-cast Concrete Foundation table to add transformer voltage details. Notes were revised and expanded.
26 & 27	Removed requirement for a telephone line conduit. Add Note 1, deleted old Note 5, and renumbered Notes.
29	Added drawing (top right) illustrating acceptable conduit locations. Notes were revised and expanded.
31	New Exhibit. Typical Underground Service - Traffic Signal, CATV, or Communication Stand-Alone Equipment.



## 1.0 INTRODUCTION

This Guide is published to provide pertinent specifications, information, and guidance to assist customers and their architects, engineers, builders, and contractors in planning for and obtaining a safe and prompt electric service.

The information and exhibits contained herein convey general knowledge and do not provide every detail or every requirement. Furthermore, this information is supplementary to, and does not intentionally conflict with the National Electrical Code (NEC), the National Electrical Safety Code (NESC), the Company's current applicable Tariffs (as defined in Section 2.0), or such state and municipal laws and ordinances as may be in force and applicable within the cities, towns, or communities in which the Company furnishes electric service. It is always necessary for customers and contractors to comply with state statutes, local ordinances, and the Company's Tariffs on file with the Pennsylvania Public Utility Commission or Public Service Commission of New York. To the extent that any information included in this Guide contradicts any terms in the Company's current applicable Tariff, the Tariff provision shall govern.

The Company shall have the right to refuse to connect any wiring or installation that does not fully meet the aforementioned requirements, regulations, and rules. The Company shall also have the right to disconnect the wiring or installation of any customer violating any such requirements, regulations, or rules. Any such action by the Company is not intended and does not imply that the Company undertakes any obligations to inspect the customer's wiring and electrical facilities, to assume any obligations, or to make any representations concerning their adequacy, safety, fitness for purpose, or other qualification. Nothing in the aforementioned requirements, regulations, rules, or in this Guide shall be construed as imposing or undertaking such obligations or representations.

All inquiries regarding service requirements shall be directed to the Company's local Engineering Services Section. Inquiries regarding specific meter related requirements can be directed to the Company's local Metering Services Section. Any inquiries regarding the NEC or local codes shall be directed to the local inspection authority.

Mandatory rules of this document are those that identify actions that are specifically required or prohibited and are characterized by the terms **shall** or **shall not**.

This Guide is subject to periodic revision and will be re-issued on an as needed basis. It is the responsibility of the user to obtain the current version. The current edition of this Guide supersedes all previous editions or versions.

The current edition of this guide is always available on the FirstEnergy Corporate website at [www.firstenergycorp.com](http://www.firstenergycorp.com). At the top of the page click on "**Electrical Company**" and then click on your specific Operating Company. Then at the bottom, right of the page under "**General Information**" click on "**Customer Guide for Electric Service**."

**Comments, corrections, and suggestions regarding this document should be submitted in writing to the Director, Operations Services at FirstEnergy Service Company, Energy Delivery Operations Services Department, 76 South Main Street, A-GO11, Akron, Ohio 44308.**

## 2.0 DEFINITIONS

Terms frequently used in this Guide are defined below (for additional definitions, refer to the latest edition of the National Electrical Code):

- **American National Standards Institute (ANSI):** ANSI is an independent administrator and coordinator of voluntary industry standards ([www.ansi.org](http://www.ansi.org)).
- **American Transmission Systems, Incorporated (ATSI):** ATSI is one of FirstEnergy's electric transmission subsidiaries.
- **Ampacity:** Ampacity is the maximum current, in amperes (amps), that a conductor or equipment can carry continuously under the conditions of use without exceeding its temperature rating.
- **Application for Service:** Application for service is a formal request submitted by the customer or their agent to the Company stating their desire to obtain electric service at a certain time and location. Applications may be processed by e-mail, telephone, or fax through the Company's Customer Service Center.
- **Approved:** Work or equipment that is acceptable to the FirstEnergy Operating Company or to the Authority Having Jurisdiction (e.g., electrical inspector).
- **Authority Having Jurisdiction (AHJ):** An organization, office, or individual responsible for enforcing the requirements of a code or standard, or for approving equipment, materials, an installation, or a procedure (e.g., electrical inspector).
- **Central Business District (CBD) Network:** A CBD network is a specialized electrical underground system that serves a defined area commonly located in the heart of the city (a.k.a. downtown) that is typified with a high concentration of multistory commercial, retail, and office buildings.
- **Class of Service:** The characteristics of electric service described in terms of voltage, phases, frequency (i.e., 60 Hertz), and number of service wires (i.e., 3- or 4-wire).
- **Clearance:** Clearance is a specified minimum distance between two objects (measured surface-to-surface) to assure adequate space for safety, security, or access.
- **Code:** The National Electrical Code (NEC), National Electrical Safety Code (NESC), or other electrical codes or regulations that are in effect and are applicable in the area served.
- **Company:** In this Guide, Company refers to the four PA FirstEnergy Operating Companies (FEOC) operating in Pennsylvania and New York – Met-Ed, Penelec, Penn Power, or West Penn Power.
- **Current Transformer (CT):** Current Transformer is a transformer whose secondary current is a precise fraction of its primary current. (CTs are generally referred to as an instrument transformer).
- **Customer:** Any person, partnership, association, corporation, or agency of municipal, county, state, or federal government receiving any service rendered by the Company at a contract location. This includes the party using the Company's service, or in applicable cases, the property owner, developer, or any party working on behalf of the customer such as an engineer, builder, contractor, or developer.
- **Customer's Installation (Electrical):** All wiring, conduit, meter socket, service disconnecting devices, appliances, lighting, and other equipment installed and/or owned by the customer on the customer's premises for the customer's use. The installation of the customer's electrical equipment is typically governed by the NEC as well as other local rules.
- **Customer Guide for Electric Service (CGES):** FirstEnergy document detailing the Company's requirements by state for electric service to individual locations including information on service laterals, meter installations (less than 600 V), and customer equipment.

- **Developer:** The individual, company, or organization responsible for the construction of the planned project of residential, commercial, and/or industrial recorded plot plan requiring multiple electric services from the Company.
- **Development:** A planned project which is developed by a developer/applicant for electric service set out in a recorded plot plan of five or more adjoining unoccupied lots for the construction of single-family residences, detached or otherwise, mobile homes or apartment houses, all of which are intended for year-around occupancy, if electric service to the lots necessitates extending the utility's existing distribution lines.
- **Distribution Lines:** Company lines (medium voltage and below) typically located in the public rights-of-way in/or along streets, alleys, highways, or on private property for general distribution of electric service to customers. The electrical distribution system collectively includes the primary, secondary, and services.
- **Environmental Protection Agency (EPA):** The EPA is an [agency](#) of the [U.S. federal government](#) that protects human health and the environment by writing and enforcing regulations based on laws passed by Congress. ([www.epa.gov](http://www.epa.gov)).
- **Federal Aviation Administration (FAA):** The Federal Aviation Administration is the national aviation authority of the United States. The FAA is an agency of the United States Department of Transportation and has authority to regulate and oversee all aspects of American civil aviation ([www.faa.gov](http://www.faa.gov)). FAA requires notification when working near aviation facilities and may impose pole placement or pole height restrictions to maintain aviation safety.
- **Final Grade:** Final grade is the eventual permanent ground level after all finished grading, paving, and landscaping is completed. Final grade shall be used when determining minimum clearances for overhead and underground facilities.
- **High-Leg:** On a four-wire, delta-connected system where the midpoint of one phase winding is grounded to supply lighting and similar loads, the conductor or busbar having the higher phase voltage to ground shall be durably and permanently marked by an outer finish that is orange in color or by other effective means. Such identification shall be placed at each point on the system where a connection is made if the grounded conductor is also present (reference NEC Article 110.15 & 230.56).
- **Instrument Transformer:** An instrument transformer is a high-quality transformer that accurately reproduces in its secondary circuit, a current (CT) or a voltage (VT) in proportion to the current or voltage in the primary circuit, respectively. Instrument transformers are typically used for revenue metering or protection schemes.
- **Institute of Electrical and Electronics Engineers IEEE:** IEEE is an organization composed of engineers, scientists, and students. IEEE is best known for developing standards for the computer, electrical, and electronics industries ([www.ieee.org](http://www.ieee.org)).
- **Line Extension:** The extension of the Company's distribution system from the nearest suitable and available distribution line to the service line which will provide service to the customer. Line extension rules and costs are further defined in each Operating Company's Tariff with the state.
- **Listed:** Equipment, materials, or services included in a list published by an organization (e.g., "UL Listed") that is acceptable to the Authority Having Jurisdiction and concerned with evaluation of products or services, that maintains periodic inspection of production of listed equipment or materials or periodic evaluation of services, and whose listing states that the equipment, material, or services either meets appropriate designated standards or has been tested and found suitable for their specified purpose.
- **Meter:** Meter is a device for accurately measuring the electric power and energy consumed by a customer. The Company supplies, installs, and maintains the meter.
- **Meter Socket:** A meter socket is a mounting device consisting of meter jaws, connectors, and enclosure for receiving a socket-type meter.

- **Mobile Home:** A mobile home is a manufactured home that complies with the mobile home definition in the NEC. In this Guide, a mobile home is a unit with a permanent chassis that is designed to be used as a dwelling without a permanent foundation. It shall be supplied under the provisions of Exhibits 13 and 14 and the NEC.
- **National Electrical Code [NFPA 70] (NEC):** The NEC is a set of national regulations that govern the installation of electrical equipment located on the customer's side of the point of service. All NEC references refer to the 2020 (or later) version of the NEC.
- **National Electrical Safety Code [IEEE C2] (NESC):** The NESC is a set of national regulations that govern the installation, operation, and maintenance of the electric supply and communication lines. NESC applies to equipment located on the electric utility's side of the point of service. All NESC references refer to the 2017 (or later) version of the NESC.
- **National Fire Protection Association (NFPA):** The NFPA is a United States trade association, albeit with some international members, that creates and maintains private, copyrighted, standards and codes for usage and adoption by local governments ([www.nfpa.org](http://www.nfpa.org)).
- **Notification or Design Request (DR) Number:** A unique number assigned by the Company used for designing, tracking, constructing, and billing of a specific job by the Company Contact Center. This number should be used in any communication with the Company Contact Center.
- **Occupational Safety and Health Administration (OSHA):** OSHA is a federal government agency in the Department of Labor that adopts and enforces regulations to maintain a safe and healthy work environment ([www.osha.gov](http://www.osha.gov)).
- **Pennsylvania Public Utility Commission (PaPUC):** The PaPUC is the state regulatory agency that has jurisdiction over all Pennsylvania electric utilities ([www.puc.state.pa.us](http://www.puc.state.pa.us)).
- **Point of Service:** Point of service is that point where the Company's electrical equipment or conductors connect to the customer's electrical conductors or equipment of the facility. The "point of service" is also commonly known as the "point of delivery."
- **Power Factor:** The ratio of Watts to Volt-Amps. Typically, expressed as a percentage. Refer to Section 8.2.
- **Private Right-of-Way:** – The right-of-way or easement for electric facilities on, over, under, across and/or through real or other property owned by an individual or entity which is not a governmental, municipal, or other public body to provide service.
- **Public Service Commission of New York (NY PSC):** The NY PSC is the state regulatory agency that has jurisdiction over all New York electric utilities ([www.dps.ny.gov](http://www.dps.ny.gov)).
- **Qualified Person (Electrical):** A person who has skills and knowledge related to the construction, operation, and maintenance of the electrical equipment and installations and has received safety training to recognize and avoid the hazards involved.
- **Raceway:** A raceway is an enclosed channel used for holding wires or cables.
- **Secondary/Secondary Main:** Company-owned conductors (cables) connected to the secondaries of distribution transformers from which customers services are supplied (less than 600 V).
- **Select Backfill:** Select backfill is graded sand, stone dust, limestone dust, earth, or topsoil that is free from large or sharp objects, rocks, scrap building material, or corrosive material. Materials that "set up" such as fly ash, culm, and foundry waste are not acceptable. It is used to backfill a trench for buried conduit and is used to ensure the future integrity of the conduit and buried electrical cables.
- **Service:** Delivering electric energy from the Company's distribution system to a single point of connection at a customer's premises.

- **Service Drop:** A service drop is a Company-owned set of overhead conductors (including the connectors) that extend from the last pole or other aerial support to the customer-owned service entrance conductors at the building or other structure.
- **Service-Entrance Conductors, Overhead System:** The service entrance for an overhead system is the group of service conductors running between the terminals of the service equipment and a point usually outside the building, clear of building walls, where joined by tap or splice to the service drop.
- **Service-Entrance Conductors, Underground System:** The service entrance for an underground system is the group of service conductors running between the terminals of the customer-owned service equipment and the point of connection to the Service Lateral.
- **Service Equipment:** Service equipment is the necessary customer-owned electrical equipment, usually consisting of circuit breakers or switches and fuses, and their accessories, located near the point of entrance of supply conductors to a building, and intended to constitute the main control and means of cutoff for the electrical supply to that structure.
- **Service Lateral:** A set of underground service conductors extending from the Company's electric distribution facilities, including any risers at a pole or other structure or from transformers, handholes, or pedestals to the first point of connection to the service entrance conductors in a terminal box, meter, or other enclosure with adequate space, inside or outside the building wall.
- **Service Territory (electric):** Service territory is a defined area in which a given electric utility can legally provide service. The area is governed by a set of agreements and maps on file with the PaPUC or NY PSC.
- **Tariff:** Tariffs are a set of rate schedules and riders, rules, and regulations for providing electric service throughout each Operating Company's service territory. The applicable Company Tariffs are filed with and approved by the PaPUC (Pennsylvania) or NY PSC (New York).
- **Temporary Service:** A service line, meter, and/or other work supplied by the Company to the customer for electric service for construction purposes or for a limited duration, typically no longer than one year, and delivered to a single point through one meter.
- **Trans-Allegheny Interstate Line Company (TrAIL Co):** TrAIL Co is one of FirstEnergy's electric transmission subsidiaries.
- **Underwriters Laboratories (UL):** Underwriters Laboratories is an independent product testing and certification organization ([ulstandards.ul.com](http://ulstandards.ul.com)).
- **Uninterruptible Power Supply (UPS):** An uninterruptible power supply (e.g., battery or flywheel backup) is an electrical apparatus that provides emergency power to a load when the input power source is not available.
- **Voltage Flicker:** Voltage flicker is defined as a sudden fluctuation in system voltage, which can result in objectionable changes in the light output of electric lamps.
- **Voltage Transformers (VT) (a.k.a. Potential Transformers (PT)):** VT is a parallel-connected type of instrument transformer, used for metering of customer's load. VTs are designed to present negligible load to the supply being measured and to have an accurate voltage ratio to enable accurate metering.

### 3.0 GENERAL INFORMATION

#### 3.1 Availability & Character of Service

The information contained in this Guide refers predominately to service requirements at the usual voltages for residential and general service installations. Service installations greater than 600 volts are not covered in this Guide. The customer shall contact the Company with questions regarding service at voltages greater than 600 volts. The Company's rules, regulations as filed with PaPUC and NY PSC shall apply to the installation and use of the service furnished.

The customer shall consult the Company to determine whether the desired service is available in the specified location. This request should be made well in advance of the date actual service connection is required. If service is available, determine its exact character; that is, the voltage (such as 120/240 V, 208Y/120 V, or 480Y/277 V), single-phase, three-phase, network, etc., since these characteristics may vary by locations. These characteristics are especially important for the proper operation of motors and other major equipment. Normally, this information will be provided in writing from authorized Company personnel to avoid possible misunderstanding.

The Company may, if requested, advise, and assist existing or prospective customers in the general selection of electrical equipment, facilities, capacitors, and protective coordination. The Company will provide information concerning rates.

### 3.2 **Application for Service**

The customer shall make applications for each class of service for new, upgraded, or relocated, permanent or temporary service or when the customer identity changes. Before service is supplied by the Company, the customer shall complete the application process. Application may be submitted via the telephone, fax, or the Internet to a Company business office; and should be submitted, **well in advance** of the date, actual service is required. The appropriate telephone and fax numbers and Internet address are listed below:

<b>Pennsylvania Companies</b>	<b>Telephone Number</b>	<b>Fax Number</b>
Met-Ed	800-545-7741	877-289-3674
Penelec (includes NY)	800-545-7741	
Penn Power	800-720-3600	
West Penn Power	800-686-0021	

A copy of the *Fax Application Builder Install Request Form 1046* can be found in Appendix 1. Application for electric service can found online at [www.firstenergycorp.com/builders-contractors](http://www.firstenergycorp.com/builders-contractors). Then click on "Establish or Upgrade Service Form" under the heading "[Online Form for New Construction or Service Upgrade.](#)"

After all necessary customer information is received and all customer requirements are met, the typical minimum lead-time to complete Company work is as follows:

<b>Type of Extension</b>	<b>Lead-time</b>
Residential Service Drop / Lateral	4 weeks
Residential Line Extension	8 weeks
Commercial/Industrial Drop / Lateral	6 weeks
Commercial/Industrial Line Extension	16 weeks
Residential /Commercial /Industrial Development	16 weeks
Large Residential / Commercial / Industrial Development (20 or greater lots)	24 weeks

These recommended minimum lead-times should allow service to be established as near to the desired time as practicable. Upon request, your Company representative will provide additional information on service details, work scope, and timelines.

The following information is required from the customer. The Company cannot begin work until all the necessary information is provided:

1. Service address (including nearest intersecting roads),
2. Lot number (and block number where applicable) and subdivision name,
3. County/Tax District name,

4. Contact persons (developer/architect, electrical contractor, etc.) names, addresses, mailing addresses, e-mail addresses, and their telephone/fax numbers,
5. Owner name, address, mailing address, e-mail address, and telephone/fax numbers,
6. Person to be billed (including their Tax ID or Social Security Number) and their mailing address,
7. Type of electric service desired – overhead (OH) or underground (UG),
8. Service voltage desired (e.g., 120/240 V single-phase, 208Y/120 V three-phase, or 480Y/277 V three-phase),
9. Amp rating of the main disconnecting means,
10. If Residential: Determine heating fuel (oil, gas, electric, etc.), water heater fuel, electric range, air conditioning (size, if yes), total square feet, preferred electric meter location, and number of services. Also, determine if any other large or special electric loads (e.g., welder or kiln) will be used.
11. If General Service (Commercial/Industrial): Electric one-line, load information (nameplate data) for all single-phase motors larger than five hp, three-phase motors larger than ten hp, tons of air conditioning, kW process heat, kW lighting, kW computers, presses, welders, x-ray machines, and other equipment having an in-rush current or other potentially disturbing characteristic, as well as other unusual loads.
12. For Developments: An approved plot plan drawn to scale showing crossroads, proposed structures, wells, septic, decks, drives/parking areas, pools, ponds, preferred service route, planned major landscape changes and future development areas, and any other known or proposed obstructions that may interfere with the Company supplying electric service. Electrical loading information will be required for the design. The customer/developer shall provide an executed and recorded Company standard blanket utility easement for their developments prior to individual lots being sold or the installation of any Company electrical facilities.
13. Date that the electric service is wanted.
14. For interconnected generation (solar, wind, etc.), refer to Section 8.6.

The customer/developer shall provide the Company with a copy of the customer plot plan showing the locations of buildings, lot numbers, property lines, streets, parking lots (if applicable), easements, underground facilities, obstructions, or utilities (if known), as well as proposed electric service entrances and metering locations. When requested, the customer/developer shall stake the locations of all proposed buildings, the lot lines, underground facilities or obstructions, driveways, and parking areas so that the Company can decide where to install its facilities.

The Company may refuse to provide electric service, consistent with Pennsylvania or New York laws and the appropriate Operating Company's filed Tariff.

### **3.3 Line Extensions**

To avoid delay, customers desiring service beyond the existing electric distribution lines of the Company shall contact the Company regarding the conditions under which service will be extended and make the necessary arrangements before wiring installations are commenced. Depending on the situation and the nature of the facilities desired or required, the customer may be responsible for some of the preparation and clearing of the property to remove trees, vegetation, and obstacles or to provide the following items: access to Company vehicles and personnel, acquisition of recorded rights-of-way, easements, or permits, construction costs, and, for underground extensions, trenching and backfilling. Note: difficulties in obtaining private rights-of-way and governmental permits (e.g., FAA, Army Corp of Engineers, or EPA permits) may result in significant delays to the construction.

Cost contributions are defined in the applicable Company's Tariff. The Company can provide the terms and conditions of extending its facilities to supply service upon request.

### **3.4 Number of Services & Meters**

The Company will connect only one set of service conductors to each separate dwelling (single or part of a multiple unit), apartment, farm, commercial or industrial establishment as one customer

through one meter or one unified set of meters for each class of service. Therefore, customers will typically be served at one voltage at either single-phase or three-phase, but not both. If the service location is occupied by several customers, each customer may have one meter for each class of service rendered. All customer installations shall conform to the NEC and local codes. Parallel runs of service cable extending from Company-owned equipment to multi-position meter centers should be avoided and require prior Company approval.

Upon request and if Company approved, a second service may be permitted based on the exceptions listed in NEC Article 230.2. A permanent plaque or directory shall be installed at each service drop or lateral, or at each service equipment location. It shall denote all other services on or in that building or structure, and the area served by each.

### **3.5 Use of Service by the Customer**

Customer-owned wiring and electrical equipment shall be sufficiently sized (per NEC) and listed for its intended application.

The customer's wiring and equipment including the self-contained meter socket shall be installed and maintained by the customer, at the customer's expense, and in the condition required by the insurance providers, governmental authorities having jurisdiction, and Company requirements.

It is necessary for the protection of the customer that all the customer's electrical work, wiring, and apparatus be installed and maintained by a qualified electrician. A qualified electrician is one who has the skills and knowledge related to the construction and operation of the electrical equipment, systems, and installations and has received safety training to recognize and avoid the hazards involved.

The Company-owned facilities, which are used to provide electrical service have limited capacity and may be damaged if overloaded. Therefore, the customer shall notify the Company prior to increasing their energy usage or altering their service equipment so that Company facilities of proper capacity may be provided. Failure to properly notify the Company of such additional requirements may result in an extended outage or in damage to the customer's and/or Company's equipment. The customer shall be responsible for all expenses and/or damages to the customer's and/or Company's facilities resulting from failure to give proper notification. The customer may also be subject to charges by the Company for work required to meet the customer's alterations. The customer should contact the Company for information concerning charges for such work in advance of undertaking such work.

Additionally, for a customer-owned and installed underground service lateral, if a customer increases the service lateral length or load, the customer shall be responsible to verify that ampacity, voltage drop, and voltage flicker limitations are suitable to serve the increased total load. If load is being added, the customer shall advise the Company so that the Company can ensure all Company associated facilities are adequate to serve the increased load.

The service shall not be used in any manner that disturbs or impairs the operation of the Company's system or that will interfere with service to other customers. If such interference does occur, due to the use of apparatus installed upon a customer's premises, such customer shall either discontinue the use of such apparatus or make the necessary revisions to the apparatus, including additional equipment that may be required to alleviate such conditions, or the Company shall have the right to discontinue the offending service.

For proper service, the wiring on all single- or three-phase installations shall be arranged so that the load, to the extent possible, is balanced among each phase-wire. For three-phase services, the load imbalance between phases shall not be greater than 15 percent of the customer's peak load.



### **3.6 Interruption & Liability\***

The Company will endeavor, but does not guarantee, to furnish a continuous supply of electric energy and to maintain voltage and frequency within reasonable limits. The Company shall not be liable for any loss, cost, damage or expense that the customer may sustain by reason of damage to or destruction of any property, including the loss of use thereof, arising out of, or in any manner connected with, interruptions in service, variations in service characteristics, high or low voltage, phase failure, phase reversal, the use of electrical appliances, or the presence of the Company's property on the customer's premises, whether such damages are caused by or involve any fault or failure of the Company or otherwise except such damages that are caused by or due to the willful and wanton misconduct of the Company. The Company shall not be liable for damage to any customer or to third persons resulting from the use of the service on the customer's premises or from the presence of the Company's appliances or equipment on the customer's premises.

### **3.7 Final Connections**

Residential/Commercial - All final connections for temporary or permanent service, between the Company's facilities and the customer's wiring, shall be made by the Company. Refer to Exhibit 1 to determine party responsible for supplying connectors.

The Company shall assume no responsibility for changing the location of its service drop attachments if an improper location is chosen without consultation with the Company, or if the Company designated location is not utilized.

If it becomes necessary for the Company to change the location of its facilities or the character of the electrical service to comply with the requirements of governmental agencies, codes, or other causes beyond the Company's control, the customer shall, at the customer's expense, change its facilities (e.g., customer's wiring, service entrance, and utilization equipment) to accommodate the Company changes. (Reimbursements by governmental agencies may apply in certain cases involving roadway improvement projects.)

Service entrance equipment interrupting capacity shall meet or exceed the maximum available fault current. If necessary, the customer shall contact the Company to determine the estimated available fault current and subsequently determine the minimum required equipment rating.

### **3.8 Grounding/Bonding**

The customer shall install the service entrance so that all NEC grounding/bonding requirements are met or exceeded. The customer's service entrance shall have a minimum of two driven ground rods (8 feet minimum length) separated by at least six (6) feet. The grounding electrode conductor shall be continuous from the service entrance main disconnect to both driven ground rods. Refer to various Exhibits throughout the Guide.

For three-phase, four-wire customer-owned service laterals to a pad-mounted transformer, the customer shall not install a fifth grounding conductor into the pad-mounted transformer. In both single-phase and three-phase current transformer cabinets, the cabinet shall be bonded to the neutral bus. Do not install a fifth grounding conductor into the cabinet.

### **3.9 Electrical Inspection**

In addition to complying with the NEC, the service entrance shall be in accordance with the requirements of the Company and such state and local inspection requirements as may be in force at the time such installation was made.

---

\* To the extent this provision contradicts any terms in the Company's current applicable Tariff, the Tariff provision shall govern.

Before a new, temporary, upgraded, modified, or repaired service entrance to a customer's service location is energized, the Company should verify that the installation of the customer's meter socket and associated equipment has been inspected and approved by:

1. The local or state electrical inspection authority, or
2. For Pennsylvania only, personnel certified in accordance with the Pennsylvania Uniform Construction Code (Act 45).

When the Company deems that a potentially hazardous condition exists, it may refuse to energize the customer's service until the customer remedies any deficiencies.

**Service Restoration - Fire or Flood:** If the meter or service entrance equipment has been subjected to fire or flood conditions, an inspection from the above referenced authorities, and a release, when applicable, from a Fire Marshall or equivalent applicable authority is required before service will be restored.

**Service Restoration – Disconnected Services:** If the meter has been blocked/removed) or the service has been disconnected/removed for twelve (12) months or more, a new inspection by the local or state inspection authority is required before the service will be reconnected.

### **3.10 Meter & Seal Tampering**

Tampering means to interfere with, damage, or by-pass a utility meter, conductor, or attachment with the intent to impede the correct registration of a meter or the proper functions of a conductor or attachment so far as to reduce the amount of utility service that is registered by the meter. Tampering includes the unauthorized reconnection of a utility meter, conductor, or attachment that has been disconnected by the utility.

In the event of tampering, or theft of service by the customer, consumer, or other person, the Company shall comply with the provisions of Pennsylvania or New York law and the Company's filed Tariffs.

Breaking of meter seals and/or removal of meters by customers, electrical contractors, or other unauthorized personnel, without prior Company permission (e.g., notification to the call center) is prohibited and may be subject to penalties.

### **3.11 Meter Attachments**

No attachments by the customer or the customer's agent are permitted to Company-owned meters, meter circuits, or ancillary meter devices. This includes grounds attached to meter sockets from the telephone or CATV company.

The following are considered **un-authorized** connections when not made, installed, or performed by a FirstEnergy employee or an authorized representative of FirstEnergy:

- Any adapter placed between the revenue meter and meter socket.
- Attachments or connections to the potential or current circuits of transformer rated revenue meters.
- Any connection inside the meter socket.

Upon request by a customer, the Company will supply kWh pulses from a Company-owned meter for demand control purposes. The cost will be assessed to the customer in accordance with specific Company charges for this connection.

### **3.12 Disconnect/Reconnect of Existing Service (Upgrades/Maintenance)**

When upgrading, adding load, changing attachment point, or performing maintenance on an existing overhead service entrance, the customer shall first contact the Company's Customer Contact Center for guidance and applicable fees. Qualified electricians may be permitted to disconnect/reconnect overhead single-phase 400-amp or less service drops at the weatherhead with local Company approval. The qualified electrician shall contact the Company to determine which connectors are approved. Electricians are not permitted to disconnect/reconnect underground service laterals. All overhead and underground electrical upgrades shall be inspected prior to reconnection (refer to Section 3.9).

The Company reserves the right to update meter and service locations at the time of upgrade for the purposes of applying current clearance requirements and meter location guidelines. Service equipment installed without approval or incorrectly located shall be subject to change or relocation.

### **3.13 Locating Underground Electric Facilities**

State laws require that all excavators notify their state One-Call System prior to excavation (including driving ground rods). Trained personnel will locate and mark various underground facilities (including electrical, communication, gas, sewer, water, etc.).

First the customer/excavator shall mark all proposed excavations with white paint/chalk, white flags, or white stakes and then notify the appropriate State One-Call Agency as required before excavation begins.

To simplify the "*Call before You Dig*" calling process, **811** has been designated by the FCC as a nationwide telephone number. In Pennsylvania and New York, the caller of the 811 will be automatically transferred to the appropriate state One-Call system. You may also contact the appropriate One-Call state agency online at [www.call811.com/state-specific.aspx](http://www.call811.com/state-specific.aspx) or create electronic tickets from their respective websites or smartphone apps.

For projects in Pennsylvania (Met Ed, Penelec, Penn Power, & West Penn Power) - Call the **Pennsylvania One-Call Systems, Inc.** at least three (3) full working days but not more than ten (10) working days, excluding weekends and legal holidays, before digging at 811 or (800) 242-1776 to request that a location be marked. The Center is open 24 hours/day and 365 days/year. To obtain more information or to enter requests for locate tickets visit their website at <http://www.paonecall.org>.

For projects in New York (Penelec) - Call **Dig Safely New York** at least two (2) working days not counting the day of call but not more than ten (10) working days, excluding weekends and legal holidays, before digging at 811 or (800) 962-7962 to request that a location be marked. The Center is open 24 hours/day and 365 days/year. To obtain more information or to enter requests for locate tickets visit their website at <http://www.digsafelynewyork.com>.

### **3.14 Required Clearance from Markout for Digging in the Vicinity of Company Underground Electric Facilities**

After the underground facilities have been located (refer to Section 3.13), hand digging is required within a tolerance zone, which is 18 inches (24 inches for those portions of Penelec located in the state of New York) from all sides of the markout stake, flag, or hash mark and the closest edge of any parallel trench dug by another party adjacent to the Company's underground facilities.

### **3.15 Buildings/Structures & Swimming Pools/Spas/Hot Tubs near Electric Lines**

Buildings and structures (including signs, flagpoles, light standards, antennas, or aerials) shall not be installed under, over, or in such proximity to electric lines where they could be raised into or fall onto such electrical lines or when they cannot be safely maintained. Antennas, aerials, or any device shall not be attached to a Company pole or any pole supplying electric service to the customer without

specific written Company authorization. NESC/NEC clearances shall be maintained. The customer shall consult the Company for specific clearance requirements and possible easement restrictions.

The Company does not allow placing a swimming pool, spa, or hot tub under its existing service drop or other electrical conductors. Specifically, a swimming pool shall not be located within a minimum of twenty-five (25) feet of the Company's overhead conductors measured horizontally from the edge of the pool. The clearance between the Company's underground cables (primary and secondary) and the edge of the pool or its auxiliary equipment shall not be less than five (5) feet (measured horizontally).

### **3.16 Attachments on Company-Owned Facilities**

Under no conditions shall the customer's facilities or other equipment such as signs, posters, banners, or notices be installed on the Company's poles or other property unless special arrangements have been made with the Company prior to installation. The requestors shall contact the Company for details. The Company does not permit painting of Company-owned equipment by the customer.

### **3.17 Clearance of Trees from Power Lines**

#### Trees & Transmission Rights-of-Way

- ATSI, TrAIL Co, and the Company's long distance, high voltage transmission lines provide power to thousands of our customers and are vital reliability links with other utilities across the country. Keeping our transmission rights-of-way free of unwanted trees and other vegetation is important to providing reliable and safe electric service.
- All vegetation on or adjacent to the right-of-way shall be low-growing, compatible species. Additional information on correct tree selection can be found at [www.firstenergycorp.com/trees](http://www.firstenergycorp.com/trees). Then click on "Maintaining Transmission Rights-of-Way" on the left side of the page.

#### Trees & Distribution Lines

- Tree related incidents are a major cause of electrical outages. Therefore, care shall be exercised when planting trees to make certain that they will not interfere with distribution power lines, even when the trees reach full, mature growth. Trees that grow more than 25-feet tall should not be planted within 20 feet of distribution power lines.
- Additional information on correct tree selection can be found at [www.firstenergycorp.com/trees](http://www.firstenergycorp.com/trees). Then click on "Selecting the Right Tree for the Location" on the top, right side of the page.

### **3.18 Access to Customer's Premises**

The customer or, if applicable, the landlord, shall grant the Company's employees and its authorized agents access to the customer's premises at all reasonable hours for the purposes necessary in connection with supplying and maintaining service, and upon termination of service, to remove all Company facilities. In the event of an emergency, the Company's employees and authorized agents shall have access to customer's premises at any time. Authorized Company employees are furnished with a photo identification badge with the Company logo. This badge is available upon request when Company employees are visiting the customer's premises.

The customer shall not block access to Company equipment by installing any obstructions (including vegetation, fences, or walls) that prohibit access to Company equipment. The customer shall be responsible for all expenses and/or damages for blocking access to any Company equipment. The customer shall contact the Company for details.

Note: Company personnel are not permitted to climb onto the customer's roof. Therefore, all connections and other Company work shall be accessible from a ladder or bucket truck on a suitable surface for the equipment.

If a customer, property owner, or landlord fails to grant the Company access for reasons described above, and legal action is necessary to secure such access, the Company may collect from the customer or the property owner all costs incurred to secure such access.

### **3.19 Company's Equipment on Customer's Premises**

The customer shall provide without cost to the Company, satisfactory recorded rights-of-way, and a suitable location for the Company's equipment, which is necessary for supplying service to the customer on the premises owned or leased by the customer.

The customer shall provide truck access to all poles, transformers, and other equipment installations designated by the Company. The truck access drive shall be a minimum of twelve (12) feet in width, installed to withstand a 40,000-pound line truck and associated equipment for lifting or hauling (i.e., cranes, flatbed trailers) including the weight of the piece of equipment, and be located within ten (10) feet of the designated piece of equipment. All access drives shall be permanent, continual, maintained, and visible for all-season access. The customer shall contact the Company for details.

### **3.20 Requested Protection for Persons Working Near Company Facilities**

The customer or contractor shall provide reasonable advance notification to the Company when proposed work is to be performed within such distance of the Company's facilities that may be hazardous to the person(s) performing the work or may otherwise be in violation of federal (e.g., OSHA, NESC) or state regulations. Upon request by the customer or contractor, the Company may cover, de-energize, or temporarily move its facilities in the work area, as it deems appropriate. The Company may bill the notifying customer or contractor for the total cost of performing such work. If circumstances require Company work outside the normal work hours, costs for the overtime period will be computed and billed at overtime rates. The customer or contractor will be required to sign an Acknowledgement/Indemnification Agreement. The customer should contact the Company in advance for details.

## **4.0 TEMPORARY SERVICE**

When requested by the customer, the Company may provide a temporary overhead or underground service. The service entrance, meter, and other wiring on temporary indoor or outdoor installations are installed in the same manner as for permanent installations. When no building is available for the installation of service conductors and service equipment, the customer shall consult the Company's local office for recommendations as to suitable support for the service drop or termination of service lateral, meter, and weatherproof housing for the service equipment. Refer to Exhibit 3 (overhead) and Exhibit 4 (underground) for typical requirements for temporary service structures.

An application for service is required for any temporary service. Refer to "Application for Service" Section 3.2 for additional information regarding temporary service.

Temporary electric service installations should not exceed one year.

Per the Tariff, the service drop (overhead) or service lateral (underground) shall be extended from the existing overhead secondary, pad-mounted transformer, pedestal, or handhole. The customer shall contact the Company for applicable fees and limitations.

## **5.0 PERMANENT SERVICE – OVERHEAD**

### **5.1 General**

The customer, architect, or contractor shall contact the Company prior to the start of construction to ascertain the point of attachment for the service drop, type of metering facilities, costs, and other information relative to the customer's service installation. Where overhead distribution facilities are available, the Company will install a suitable overhead service drop to a point of attachment on the customer's premises as designated by the Company. The point of attachment will be located to

provide the least cost and shortest practicable service drop distance to the Company's facilities. The point of service is the connection of the overhead service drop to the customer's service entrance conductors/equipment. The Company shall provide, own, install, and maintain the service drop conductors from the overhead distribution system to the point of service.

The customer shall provide and maintain a safe, substantial support for the Company's overhead service conductors. The service drop support shall be installed in such a manner to maintain the clearances specified in Section 5.2 and Exhibit 2. The customer shall furnish, install, and maintain the service bracket necessary for the attachment of the Company's service drop conductors (refer to Exhibit 7). In cases where a service mast is required, only power service-drop conductors shall be attached to the service mast.

In general, service entrance conductors should be installed on the outside of the building to be served.

When the customer's load necessitates parallel service entrance conductors, the customer shall furnish and install suitable equipment (Company approved) to allow the Company to connect the service drop with a single set of attachments. The customer shall minimize the number of conductors to reduce both the electrical connections and the complexities inherent in such installations.

Refer to Section 3.8 and Exhibit 5 for grounding requirements.

Refer to Exhibits 1, 2, 5, 6, 7, 11, and 14, for typical installations.

## **5.2 Service Drop Clearances**

The point of attachment of the service drop to the building shall be such that the drip loop shall not be less than ten (10) feet above the ground. In addition, the point of attachment shall be located to allow the customer to comply with NESC/NEC clearance requirements and the Company to comply with NESC/NEC clearance requirements. The attachment should not be more than 24 feet above ground unless a greater height is necessary for proper clearances.

The service drop should not be installed over buildings or swimming pools, spas, or hot tubs.

Some of the more common NESC/NEC minimum clearance requirements are listed below and most are illustrated on Exhibit 2. Note: Other clearances not listed below may be required.

- Twelve (12) feet for a multiplex service or twelve feet-six inches (12.5) for an open wire service above sidewalks and spaces accessible to pedestrians,
- Eighteen (18) feet above roads, streets, alleys, driveways, and other areas subject to truck traffic,
- Two (2) feet above communication lines (e.g., telephone or CATV) at any point of crossing, and one (1) foot at the point of attachment to the building,
- Three (3) feet between service drop conductors (attached to the buildings) and windows, doors, porches, and fire escapes,
- Five (5) feet between service drop conductors (not attached to the buildings) adjacent to windows, awnings, fire escapes and other building projections,
- Three and one-half (3.5) feet between the service drop conductors and the roofs of projections that are not accessible to pedestrians.

The service drop shall not cross over property other than that of the customer to be served unless the Company has received executed rights-of-way agreements or permits from the owners of such properties.

## **5.3 Mobile Homes or Mobile Home Parks**

The Company has an established policy for extending electric service to mobile homes and may assist in planning the installation of mobile home parks. The Company's Tariffs, as filed with the State, shall apply to the installation, and use of the service furnished.

Meter and service facilities for a mobile home or mobile home parks will be determined on a case-by-case basis.

For non-subdivision type mobile home parks, the Company recommends a group meter arrangement (Refer to Exhibit 14 for typical installations). Mobile home park operators shall be responsible for the effective grounding of all mobile homes. Additional information is available upon request from the Company.

#### **5.4 Travel Trailer or RV Parks**

Typically, electric service requirements for travel trailer or recreational vehicle (RV) parks will be served through one metering point (refer to Section 3.4). The customer should contact the Company for additional information.

#### **5.5 Central Pole Distribution Metering Service**

A farm or commercial operation with specific load requirements may have service from a customer-owned central distribution service drop. The customer shall furnish, install, and own a pole centrally located with respect to the various buildings to be served. The central distribution pole in each case shall be a dead-end pole, as far as the Company lines are concerned, without any unmetered service extending beyond it.

If it is impractical to serve all farm buildings from a centrally located pole due to distance between buildings or the necessity of crossing public roadways, the Company will provide services and meters for separate accounts for each building, as conditions require.

For details, refer to Exhibit 11 for overhead and Exhibit 12 for underground central distribution service installations.

### **6.0 PERMANENT SERVICE – UNDERGROUND**

#### **6.1 General**

The customer, architect, or contractor shall contact the Company, prior to the start of construction, to ascertain from the Company the point of attachment for the service lateral. The Company will designate a location, as close as practical, for the point of service.

Based on an engineering evaluation, a Company representative will determine the pole, transformer, handhole, pedestal, or manhole location to which an underground service lateral may be extended. Refer to Exhibit 1 for specific customer and Company installation/ownership responsibilities for each item associated with the service and for determination of the point of service. The Company retains ownership of conductors and equipment it supplies. In special situations, if the point of service varies from Exhibit 1, the customer's installation documents will clearly designate the equipment ownership and the exact point of service.

The contractor, developer, or customer shall provide all trenching, conduit, and backfilling as well as a clear, graded path for its installation. The Company shall install and maintain the service lateral conductors for residential service. The customer shall install and maintain the service lateral conductors for commercial service per the NEC and the Company specifications.

Before excavating, refer to Sections 3.13 and 3.14 for locating and marking underground facilities. Refer to Exhibit 24 for general trench details for installations of cables in conduit. Since the actual trench dimensions may vary by changes to final grade, soil condition, location, and other factors, it is necessary to confirm specific trench dimensions with the Company representative.

The customer shall provide a trench that is well tamped. Settlement and frost heave of trench backfill can result in damage to service cable, meter sockets, and house siding. The customer should install

ground movement protection per NEC 300.5 (J). The Company recommends a slip-joint conduit product, available from several vendors and suppliers (refer to Exhibit 8). Additionally, the customer should provide ample cable slack to allow for cable movement.

Customer shall coordinate the installation of customer-owned service laterals with the Company. The commercial customer installed underground service conductors shall be of sufficient length to allow the Company to complete the final electrical connections. The qualified electrical contractor shall run the service lateral to within 18 inches of the designated Company pad-mounted transformer or pedestal/handhole and leave enough coiled cable to complete the termination of the cables by the Company. Minimum additional cable lengths shall be five (5) feet for pedestals/handholes or ten (10) feet for pad-mounted transformers. For vertical risers, the qualified electrical contractor shall install the underground portion of the customer-owned service lateral and then leave a sufficient length (consult the Company) of coiled cable, at the base of the pole. The customer may be required to supply the conduit, brackets, and weatherhead per Exhibit 1. The Company shall terminate the cables in the pad-mounted transformer or on the Company-owned pole. Customer/electrician shall contact the Company before installing any facilities. The customer shall contact the Company for network installations.

The customer shall be responsible for connecting all service entrance conductors to any form of customer-owned disconnecting devices or equipment. The Company will be responsible for providing all connectors and making all connections to its power transformers, manholes, handholes, and pedestals regardless of whether involved conductors are Company or customer owned.

Refer to Section 3.8 and Exhibit 5 for grounding requirements.

Additionally, for a customer installed and owned underground service lateral, if a customer increases the service lateral length or load, the customer is responsible to verify that ampacity, voltage drop, and voltage flicker limitations are suitable to serve the increased load. If load is being added, the customer shall advise the Company so that the Company can ensure all Company-owned facilities are adequate to serve the increased load.

No fence, guardrail, wall, or other obstruction shall be placed near pad-mounted equipment (e.g., transformers, handholes, pedestals, or switchgear) that would limit the Company from performing maintenance or repair of the equipment. This includes any tree, shrub, bush, or other vegetation that would have to be removed to operate, maintain, or replace equipment. The minimum clearance is three (3) feet from the back and sides, and ten (10) feet from the front of all pad-mounted equipment or any pad-mounted equipment doors. Refer to Exhibits 22 and 23. Additionally, a customer shall not cover (even partially) any of these devices with plants, mulch, dirt, rocks, artificial rocks, or other landscaping as this prevents them from being quickly located, safely operated, as well as accelerating their corrosion. Company shall not be responsible for replacing shrubs, plants, fences, wall screenings, or other obstructions that need to be removed for maintenance or restoration work.

## **6.2 Underground Services from Overhead Lines**

Refer to Exhibits 8, 9, 10A, and 10B for typical installations.

When it becomes necessary for the Company to replace a pole, upon which a customer-owned underground service lateral terminates, the necessary changes to the underground service conductors shall be made by the customer at the customer's or cost causer (pole joint use) expense. (Note: Reimbursements by governmental agencies may apply in certain cases involving roadway improvement or widening projects.)

## **6.3 Underground Services in Underground Residential Areas**

For single-phase customer-owned underground services at 400 amps or less, the customer shall install only one set of service cables sized for the expected load. Multiple or parallel sets of cables are not acceptable for services at 400 amps or less. Refer to Exhibit 1 and Exhibit 8.



For services greater than 400 amps, the customer shall consult the Company as soon as possible during the building design stage to discuss the multiple or parallel cable service requirements and limitations.

Due to connector physical limitations, cable size shall be limited to 750 kcmil when terminating in a handhole, pedestal, or in a single-phase pad-mounted transformer.

#### **6.4 Underground Services in Underground Commercial Areas**

The Company shall provide, install, and maintain the necessary primary/secondary cables, transformer(s), and switchgear to provide electric service as well as a pad-mounted enclosure, handhole, pedestal, or other suitable means to terminate the service lateral cables.

The customer shall provide the Company with suitable space at a location designated by the Company to accommodate the necessary transformation and switching equipment required to supply the customer's load. Space requirements may vary depending on the customer's load and service requirements, as well as the availability of Company facilities in the area. It is therefore imperative that the customer contacts the Company as soon as practical in the customer's electrical design/planning stage to ensure that appropriate accommodations can be made for the required Company facilities.

When no suitable outdoor location is available, other options may be considered. Those options will require written approval from the regional Engineering Services Manager. The Company's equipment shall always be accessible to the Company. Special design requirements shall be adhered to so that the appropriate safety, maintenance, and operating conditions can be satisfied. As soon as possible during the building design stage, the customer shall consult the Company to discuss any special needs and design specifications (Company, OSHA, NESC, NFPA, NEC, etc.).

Due to connector physical limitations, cable size shall be limited to 750 kcmil when terminating in a handhole, pedestal, or in a single-phase pad-mounted transformer and limited to 1000 kcmil (maximum 8 conductors per phase) or 750 kcmil (maximum 16 conductors per phase) when terminating in a three-phase pad-mounted transformer.

For underground services at 400 amps or less, the customer shall own and install only one set of service cables sized for the expected load. Multiple or parallel sets of cables shall not be acceptable for services at 400 amps or less, unless prior written agreement is made with the Company.

For services greater than 400 amps, the customer shall consult the Company as soon as possible during the building design stage to discuss the multiple or parallel cable service requirements.

Where a service raceway or duct enters from an underground distribution system, the customer shall seal the end within the building with suitable compound to prevent the entrance of moisture (water) or gases. Spare or unused ducts shall also be sealed.

Refer to Exhibits 15, 16, 18, 19, 20, and 21 for typical installations.

#### **6.5 Underground Services in Central Business District Network Areas**

The customer shall contact the Company for specific network requirements. All services shall originate from manholes or handholes. No service shall be energized directly from a transformer vault (exception – spot networks at 480Y/277 V).

#### **6.6 Transformer Foundations & Vaults**

The customer shall provide a suitable above ground external site to accommodate a pad-mounted transformer. The site shall have compact, level ground, and not subject to flooding or pooling water. The area selected should avoid high contamination areas and areas subject to vehicle damage (e.g.,

delivery trucks, garbage trucks, snowplows, large farm equipment, etc.). The provided area shall be sufficiently sized to accommodate the installation, removal, maintenance, and upgrades in a safe manner.

For single-phase installations, the customer shall provide the excavation, and provide and install the base material (per Exhibit 29). The Company shall provide all single-phase box pad foundations and arrangements shall be made for the customer/developer to install them. Refer to Exhibit 1 (Note 9) for the party installing the foundations.

For three-phase installations, the customer shall provide the excavation and provide and install the base material, grounds, and a pre-cast box pad or concrete transformer pad in accordance with Exhibits 25, 26, 27, and 28. Refer to Exhibit 1 - Note 10 for Company specific approved foundation.

If such a site is not available, alternate options will be evaluated and approved by the regional Manager of Engineering Services. If a transformer vault is the only option available, the vault shall be furnished and maintained by the customer on the customer's premises at the customer's expense, in accordance with national, local, and Company requirements.

Transformer vaults may contain only the supply transformers and associated primary equipment and, where necessary, customer-owned secondary bus. Under no conditions are service-meters, customer-owned fuses, switches, or other customer-owned equipment to be installed therein. Secondary devices and service meters, however, should be installed as near the transformer vault as practicable, but not in it.

For certain high usage customers, current and voltage instrument transformers constitute a part of the Company's metering equipment. For distribution secondary voltages, they are usually installed in instrument transformer enclosures. For vaults in buildings, these enclosures are located outside the transformer vault, preferably on the vault wall, unless some other more desirable location is approved by the Company. Refer to Exhibits 19 and 20 for a typical metering installation with current transformers.

## **6.7 Mobile Homes or Mobile Home Parks**

Refer to Exhibits 13 and 14 for typical installations.

## **7.0 METER INSTALLATIONS**

### **7.1 General**

Meters and meter testing devices are furnished, installed, and maintained by the Company. These devices are Company-owned and shall not be moved, or the connections changed by any person other than authorized employees of the Company (refer to Section 3.10).

All metering shall be installed on the line-side of the customer's main disconnecting means except for the following:

- Where the Company requires a non-fusible meter disconnect ahead of the meter on a single-phase or three-phase 480-Volt self-contained metering installation (refer to Exhibit 15), or
- Where the NEC requires a main disconnect ahead of a group of more than six (6) meters (refer to Exhibit 16).

When emergency disconnects are required by the NEC, they shall be located on the load-side of the metering.

The customer shall consult the Company prior to purchasing or installing electrical equipment.

Meter sockets, metering transformer cabinets, and all other enclosures and switch boxes installed on the line side of the meter shall be equipped with provisions to accept a Company meter seal before

connection will be made by the Company. Meter sockets, transformer cabinets, and other meter service enclosures shall not be used by the customer as junction boxes - only service entrance conductors are permitted. Metered and unmetered conductors shall not be installed in the same conduit, enclosure, or raceway. All energized meter sockets shall always be properly covered especially if the meter has been removed. Meter sockets and service conduits shall not be recessed into the wall. Unmetered service entrance cables or service entrance conduits on buildings, poles, or structures shall not be concealed or recessed.

Meter installations that have the meter socket as part of a pedestal, multi-metered equipment, or attached to or an integral part of the customer-owned service equipment shall be approved by the Company prior to purchase and installation by the customer.

The Company, in accordance with the rate schedule selected and the type of service supplied, determines the capacity and type of meter installation to accommodate the customer's load.

## **7.2 Meter Locations**

The customer shall provide space for the installation of the Company's meters and equipment at an outside location designated by the Company. Outdoor meter locations are required for all meters except where the Company gives written approval otherwise.

### Outdoor

All new outdoor meter installations shall be located on the building at the nearest practical point from Company facilities and readily accessible to authorized Company representatives. If the nearest point is not feasible due to physical obstructions, such as garage doors or windows, the Company shall choose an alternate location closest to its service facilities.

The meter socket shall be installed by the customer so that the center of the socket is approximately five feet above the finished grade. Exceptions to this requirement to avoid obstacles or maintain safety shall be approved prior to installation. Meter socket height for pedestals, multi-meter equipment, or meter sockets attached to or an integral part of customer-owned service equipment shall be approved in writing by the Company.

Clearance in front of and to the sides of meter sockets and metering equipment shall be maintained per NEC Article 110.26 (30-inch width and 36 inches in front of the meter and extend from the grade, floor, or platform to a height of 6.5 feet or the height of the equipment, whichever is greater). The above clearances shall be maintained regardless of structural changes of the building. The location shall not be subject to severe vibration. Meters and metering equipment shall not be installed in dangerous locations or locations where the meter readers or service personnel may inadvertently damage flowerbeds or shrubbery or where it will be necessary for them to climb over fences or other obstructions (e.g., HVAC equipment, trash containers, and dumpsters) to perform their work. The meter socket shall not be installed in carports, open porches, or other areas that may be enclosed by walls or screens. Additionally, they shall not be installed in locations where they may be accidentally damaged, such as on buildings where they will extend unguarded into alleys, driveways, drive-throughs, or where they will cause inconvenience to the customer or the Company. Building exhaust fans or furnace vents shall not be vented on or near metering equipment.

A meter may be located on a customer-owned pole with prior Company approval. This pole shall be yellow pine, cedar, or equivalent, pressure-treated and provide proper clearances (refer to Exhibit 2). Before installing the pole, the customer should consult the Company for proper size (length and class) and setting depth. Any metering installation on a Company-owned pole shall have the specific written approval of the Company.

The customer shall install steel concrete filled barrier posts to protect metering equipment where vehicle traffic may interfere with or damage such equipment. Refer to Exhibit 30.

Meters shall not be located closer than three (3) feet to any natural gas equipment. For locations near tanks containing flammable gas or liquid (e.g., propane, gasoline, or oxygen) meters shall be no closer than fifteen (15) feet.

Indoor

Indoor installations shall be preapproved by the regional Metering Services Section.

Where an indoor installation is required, the meters should be located on the first floor or in the basement where they shall be readily accessible to authorized Company representatives. The location shall not be subject to severe vibration, excessive dampness, high magnetic fields, or excessive heat and shall be installed in accordance with the NEC.

**7.3 Group Meter Installations**

In multiple occupancy (two or more occupancies) buildings, where several floors, apartments, stores, etc., are rented separately, meters and service equipment shall be located preferably all together. In high-rise buildings, it may be necessary to have several meter locations, possibly every other floor or every third floor as may be necessary.

The meter room or space shall be readily accessible to all tenants and Company representatives at hours specified in accordance with the filed rates, rules, and regulations. This room shall be for the sole purpose intended and shall meet local fire codes as well as the NEC. This room shall not be used for the storage of materials or equipment.

Refer to Exhibit 16 for typical indoor/outdoor installation for multiple occupants.

**7.4 Meter Relocations**

When alterations or additions to a building or its wiring require a change in the meter location, the customer shall notify the Company before proceeding with any work. The customer may be responsible for the Company's cost for facility modifications. The customer shall be responsible for all costs incurred in the moving the meter socket and wiring.

**7.5 Minimum Meter Sockets Requirements**

Meter sockets for a service of 400 amps or less are supplied and installed by the customer. For other service sizes, refer to Exhibit 1 for customer/Company responsibilities. All customer supplied meter sockets shall meet the minimum requirements as defined below. For services greater than 400 amps, the customer should consult the Company for the appropriate metering equipment.

<b>Minimum Requirements for All Meter Sockets</b>
• Shall be UL listed and labeled,
• Meter socket jaws shall be tin-plated copper and spring supported,
• Lugs shall be extruded aluminum tin plated,
• Sockets shall be 5 <sup>th</sup> terminal adaptable (at the 9 o'clock position),
• Sockets shall be ringless type with clasp and slot closure,
• Sockets shall have ¼-inch ground wire knockout,
• Cardboard or plastic protector,
• Triple ground lug (triplex),
• Shall accept blanking plate,
• Meter sockets designed for underground service connections shall be side wired,
• Dual use meter sockets designed for both overhead and underground service connections shall be side wired,

<ul style="list-style-type: none"> <li>Combination meter sockets (w/main breaker) shall be side-wired or have line-side terminations that are bused downward,</li> </ul>	
<ul style="list-style-type: none"> <li>Socket components and connection points shall be designed, located, and adequate space provided, such that the use of horn bypass jumpers, service savers, cable pullers, and other standard electric restoration and maintenance equipment can be safely and effectively utilized by the utility.</li> </ul>	
<b>Residential Single-Phase</b>	<b>Commercial Single- &amp; Three-Phase</b>
<ul style="list-style-type: none"> <li>Shall have horn-type bypass</li> <li>Lever by-pass with jaw tension release is also acceptable</li> </ul>	<ul style="list-style-type: none"> <li>Shall have lever-operated jaw release and by-pass rated for 100% continuous duty (does not apply to single-phase temporary services).</li> <li>All sockets shall have the Landis &amp; Gyr HQ Series, the Milbank HD Series, or the Eaton/Cutler Hammer MSL Series Block Assembly.</li> </ul>
<b>Gangable Sockets:</b>	
<ul style="list-style-type: none"> <li>Maximum height to center of top socket 72 inches,</li> </ul>	
<ul style="list-style-type: none"> <li>Minimum height to center of bottom socket 24 inches (indoor) or 30 inches (outdoor),</li> </ul>	
<ul style="list-style-type: none"> <li>Minimum spacing between meters eight (8) inches,</li> </ul>	
<ul style="list-style-type: none"> <li>A 5<sup>th</sup> jaw in the 9 o'clock position required for 120/208 V 3-wire network,</li> </ul>	
<ul style="list-style-type: none"> <li>400-A units approved on a case-by-case basis,</li> </ul>	
<ul style="list-style-type: none"> <li>Residential units – no bypass lever (horns required); commercial units – bypass lever required,</li> </ul>	
<ul style="list-style-type: none"> <li>A hasp for a padlock may be provided in place of barrel lock,</li> </ul>	
<ul style="list-style-type: none"> <li>480-V units shall have disconnecting means on source side of each socket with provisions for meter seal and/or padlock.</li> </ul>	

Refer to *Meter Socket Requirements Table* on the next page.

## Meter Socket Requirements

Socket Type	Service Entrance Type / Additional Equipment	Lug Size Required Per Socket Ampere Rating			Horn Bypass <sup>3</sup>	Lever Bypass w/jaw release <sup>4</sup>	Hub Opening	Line-side KO	Side Wired <sup>5</sup>
		100 A - 125 A	200 A	400 A					
1-Ph, 1 Position, 4/5 Jaw	OH only	#6 - 2/0 AWG	#2 - 350 kcmil		X		Small	2 1/2"	
1-Ph, 1 Position, 4/5 Jaw	OH only			3/8" Stud,		X	Large	3"	
1-Ph, 1 Position, 4/5 Jaw	UG only		#2 - 350 kcmil		X		n/a	3"	X
1-Ph, 1 Position, 4/5 Jaw	UG only			3/8" Stud,		X	n/a	4"	X
1-Ph, 1 Position, 4/5 Jaw, Combo <sup>1</sup>	UG, equipped with load-side series main breaker		#2 - 350 kcmil		X		n/a	3"	X
1-Ph, 1 Position, 4/5 Jaw, Combo <sup>1</sup>	UG, equipped with load-side series main breaker			3/8" Stud		X	n/a	3"	X
1-Ph, 1 or 2 Position, 4/5 Jaw, Pedestal <sup>2</sup>	UG, equipped with load-side series main breaker		#2 - 350 kcmil		X		n/a	3"	X
1-Ph, 2 - 6 Position, 4/5 Jaw	OH/UG	#6 - 2/0 AWG (load) #4 AWG - 350 kcmil (line)			X		Small	3"	X
1-Ph, 2 - 6 Position, 4/5 Jaw	OH/UG		#2 - 350 kcmil(load) 1/0 AWG - 600 kcmil (line)		X		Large	3"	X
3-Ph, 1 Position, 7 Jaw	OH	#6 - 2/0 AWG				X	Small	2"	
3-Ph, 1 Position, 7 Jaw	OH		#6 - 350 kcmil			X	Small	3"	
3-Ph, 1 Position, 7 Jaw	UG		#6 - 350 kcmil			X	n/a	3"	X
3-Ph, 1 Position, 7 Jaw	OH/UG			3/8" Stud		X	Large	4"	X
<b>Footnotes:</b>									
1: Combo Socket - Acceptable combo sockets shall have a sufficient wireway to lay-in the line-side conductors specified. Sharp edges shall be protected with guard. Each line-side connection including the neutral connection shall be side wired and easily identified. Load-side main breaker shall be mounted in an area of the socket that is separate from the meter mounting compartment.									
2: Pedestal - Socket shall be equipped with stabilizing base or foot that extends at least 36" below grade.									
3: Horn Bypass - Self-contained sockets not requiring a lever bypass, shall have horn bypasses. Each horn bypass tab shall be mounted/positioned directly adjacent to its corresponding jaw. The 1-Ph socket requirements above are for residential installations. Any single-phase socket listed above that will be installed on a commercial rate shall be equipped with a lever bypass.									
4: Lever Bypass - Lever bypass shall be equipped with jaw tension release. Lever Bypass shall have a minimum rating equal to 100% of the socket continuous ampacity rating.									
5: Side Wired - Acceptable side wired sockets shall have each of the line-side energized connections including the neutral 'bused' to the side of the meter mounting location. The terminal connections shall be easily identified visually. The bus assembly shall be supported in a manner that can tolerate the normal downward forces on the line-side conductors.									

## 7.6 Metering Equipment Installation Guideline Summary

- The Company shall approve all metering equipment locations.
- The meter socket shall be mounted level.
- Mount the meter socket on a solid part of the structure.
- Use corrosion inhibited mounting hardware.
- Do not mount the meter socket with nails.
- Meter socket shall be surface mounted. Do not build-in or enclose the meter socket or meter within the structure.
- Do not recess the meter socket in brick, masonry, or siding.
- The installation shall meet the requirements set forth by the NEC and any local, state, or federal codes that apply to the installation. For installations that require electrical inspection, the inspection is required before the installation is connected to the Company's system.
- It is recommended that a qualified electrical contractor perform all work on customer facilities.
- Customer's meters, auxiliary devices, relays, etc., shall normally not be connected to the Company's metering circuits.
- The Company shall furnish the metering facilities required in accordance with its standard rate schedules.
- After an installation is made, changes in location of meters for the convenience of the customer will be at the customer's expense, after the necessary service entrance wiring to the new location has been completed by the customer.
- Only service entrance conductors may run through meter sockets or meter connection boxes.
- Meter sockets/enclosures shall not be used as junction boxes.
- All equipment furnished by the Company shall remain its exclusive property and the Company shall have the right to remove the same after termination of service for any reason whatsoever.
- For identification purposes, it shall be required that wherever two or more meters are grouped at one location, all sockets/metering equipment (inside and out) and breakers **shall be plainly and shall be permanently marked to designate the specific apartments**, suites or offices served (e.g., Apt 1A). Likewise, the apartment or suite entrance(s) shall be identified accordingly (e.g., APT 1A). Tags shall be used marking entrance equipment or service or service conductors, whereas sockets or meter connection boxes may be marked by neat stencils with paint as well as permanent tags (label maker tags are not acceptable). These identification markings shall be located as follows:
  - ✓ Inside main disconnect electrical panel in the apartment or suite,
  - ✓ Inside the meter socket near the jaw assembly, or
  - ✓ On the cover of both main disconnect panel and meter socket.
- For multi-meter installations, any un-metered positions shall have the cardboard shipping covers replaced by plastic protectors.
- Metered and un-metered conductors shall not be in the same trough, conduit, or wireway.
- For typical installations, refer to Exhibits 6, 8, 11, 12, 13, 14, 15, 16, 17, 18, 19, 20, and 21. In unusual cases, the customer should contact the Company.

## 7.7 Minimum Size Meter Socket - 480-Volt Services

The smallest permissible size meter socket on 480Y/277-volt three-phase four-wire services is 200 amps.

## **7.8 Installations Requiring 400 Amperes & Less of Continuous Load Current**

Typically, on new customer installations or on existing customer installations where the service entrance conductors, service entrance panel, or main disconnect switch are altered, the meters shall be installed outdoors. If an indoor installation is required, the customer shall consult the Company before starting the installation.

All services requiring 400 amperes and less shall utilize self-contained metering. During service upgrades or reconfigurations, it is recommended to evaluate the existing metering. If instrument transformers were utilized, the Company reserves the right to have customer update their metering to self-contained at the time of upgrade. If a service has been inactive the Company reserves the right to have customer update metering to self-contained.

## **7.9 Installations Requiring Over 400 Amperes of Continuous Load Current**

Before beginning any installation requiring instrument transformers, the customer shall consult the Company regarding the instrument transformers, meter location, and facilities required.

The regional Metering Services Section shall determine in each case (either new or upgrades) which type of meter installation shall be made.

Instrument transformers are required for these installations having more than 400 amps of load current. In most situations, the customer will supply and install an approved current transformer cabinet or mounting facility in accordance with Company requirements. Refer to Exhibits 19 and 20. These instrument transformer cabinets shall not be used as junction boxes or raceways (troughs). Other alternative current transformer locations (e.g., in pad-mounted transformer secondary compartment), as determined by the regional Metering Services Section, may be applicable as per Exhibit 21. All instrument transformer locations shall be readily accessible to authorized Company representatives for checking and testing. However, before such an installation is made, the Company shall be consulted regarding the meter location and facilities required.

When the space above the instrument transformer cabinet is intended as the location for the meter or meters, it is necessary that adequate space be reserved for this purpose.

For services exceeding 2400 amperes or when the service conductor size/quantity is not compatible with a CT enclosure, the customer shall provide a switchgear enclosure for metering. Switchgear compartments meeting IEEE C57.12.28 shall be a minimum of 36-inches high by 30-inches wide by 20-inches deep with a bus separation of at least 10.5 inches on center, 7.5-inch minimum separation from the enclosure sides, and located on the supply-side of any protective equipment. The bus dimension shall be a maximum of five (5) inches to allow for window type current transformers. The neutral connection is required to be in the front of the enclosure. The customer shall provide conduit or raceway for metering cables. The customer shall contact the regional Metering Services Section early in the planning stage to determine specific details and if the proposed installation allows for an alternative metering arrangement.

## **7.10 Approved Current Transformer Cabinets**

When a current transformer cabinet is required, the customer shall provide an approved unit from the table shown below. These cabinets shall not be used as junction boxes for circuit extensions and shall have line and load sides identified. No unmetered conductors are permitted within the CT enclosure cabinet.

All current transformer cabinets listed below are rated for indoor/outdoor use unless otherwise noted.



The short-circuit current ratings that will be labeled on the current transformer cabinets are included next to the catalog numbers listed below. This information is being provided so that the customer can select a unit with a short-circuit current rating equal to or greater than the available short-circuit current at the cabinet as may be required by the local or state inspection authority.

**Current-Transformer Cabinets (Over 400 Amperes to 2400 Amperes):**

- Shall be UL listed and labeled as a “Metering Transformer Cabinet,”
- Use 14 gauge electroplated galvanized or equivalent gray painted steel (or aluminum with equivalent physical strength and corrosion resistance),
- Outdoor type shall be weatherproofed,
- Double door with stainless steel hinges (or equivalent hinges for aluminum cabinet),
- Padlockable handle (for Company lock) on door with internal mechanism for three points of latching: top of door, bottom of door, and handle,
- Each door shall be equipped with a non-detachable door stop for holding it in a fixed open position,
- Typical dimensions for cabinets rated 400 A to 800 A: 36-inch wide, 36-inch high, and 10-inch deep,
- Typical dimensions for cabinets rated 1000 A to 2400 A: 42-inch wide, 60-inch high, and 20-inch deep,
- Removable copper bus bar on each phase for installation of urn-type current transformers (Company will provide current transformer dimensions upon request),
- Each bus bar shall be drilled and tapped on both ends with a 10-32 screw to facilitate connection of meter potential wires and neutral wires, and
- Bus support brackets on 600- to 800-Amp rated cabinets shall be spaced to accommodate installation of standard bar-type current transformers.

<b>Approved Manufacturer / Catalog Numbers (as of 04/2021)</b>		
<b>Manufacturer</b>	<b>CT Cabinet Catalog Number</b>	<b>Short-Circuit Current Rating</b>
<b>Size: 600 - 800 Amperes</b>		
East Coast Panelboard	CTJ-800-A (indoor)	50,000 amps*
	CTJ-800R-A (outdoor)	
Erickson Electrical	CT-84-FECD	85,000 amps
Hoffman Enclosures	A800HCT1R	50,000 amps
Lake Shore Electric	JCTC-Series	50,000 amps
Brooks Meter Devices	507U7591-1	10,000 amps
Milbank	U5990-O	50,000 amps
The Durham Company	1011245	50,000 amps*
Nav-Tech	CT-800 (indoor)	50,000 amps*
	CT-800R (outdoor)	
<b>Size: 1000 Amperes</b>		
East Coast Panelboard	CTJ-1000-A (indoor)	50,000 amps*
	CTJ-1000R-A (outdoor)	
Erickson Electrical	CT-124-FECD	85,000 amps
Lake Shore Electric	MCTC-Series	50,000 amps
<b>Size: 1200 Amperes</b>		
East Coast Panelboard	CTJ-1200-A (indoor )	50,000 amps*
	CTJ-1200R-A (outdoor)	
Erickson Electrical	CT-124-FECD	100,000 amps
Lake Shore Electric	MCTC-Series	50,000 amps
Milbank	FEM-1234UGBX	85,000 amps
<b>Size: 1600 Amperes</b>		
East Coast Panelboard	CTJ-1600-A (indoor)	50,000 amps*
	CTJ-1600R-A (outdoor)	
Erickson Electrical	CT-164-FECD	85,000 amps
Lake Shore Electric	SCTC-Series	100,000 amps
Milbank	FEM-1634UGBX	85,000 amps
<b>Size: 2000 Amperes</b>		
East Coast Panelboard	CTJ-2000-A (indoor)	50,000 amps*
	CTJ-2000R-A (outdoor)	
Erickson Electrical	CT-204-FECD	85,000 amps
Lake Shore Electric	SCTC-Series	100,000 amps
Milbank	FEM-2034UGBX	85,000 amps
<b>Size: 2400 Amperes</b>		
East Coast Panelboard	CTJ-2500-A (indoor)	50,000 amps*
	CTJ-2500R-A (outdoor)	
Erickson Electrical	CT254-FECD	85,000 amps
Lake Shore Electric	SCTC-Series	100,000 amps
Milbank	FEM-2534UGBX	85,000 amps
* To achieve rating, customer shall wrap line cables together and load cables together with nylon rope per manufacturer's instruction.		
** East Coast Panelboard CTJ-800A is no longer manufactured but may still be installed.		

## **7.11 Service at Voltages Greater Than 600 Volts**

Service at primary distribution, subtransmission, or transmission voltage level may be available dependent upon the size of the load served, location of the facility, and other economic factors and may be provided at the discretion of the Company. The customer shall contact the local Engineering Services Section well in advance of the time such service will be required so that the customer/s and the Company's engineering, design, and construction work may be properly coordinated, and equipment made available. The customer shall contact the Company well in advance of the time such service will be required so that the customer's and the Company's engineering, design, and construction work may be properly coordinated, and equipment made available. Finally, the customer shall contact the regional Engineering Services Section for additional information needed.

## **7.12 Disconnect Requirements**

### Central Business District Network Areas

The customer shall provide a lockable (for Company padlock or expendable lock) disconnecting means with overcurrent protection (e.g., fuses) before entering the metering equipment on all underground services in Central Business District network systems.

### Multiple Meter Installations

Disconnect requirements on installations with multiple meters vary dependent upon the nature of the installation and level of load served. For disconnect (main and/or individual meter) requirements, the customer shall contact the regional Metering Services Section.

### 480-Volt Self-Contained Meter Installations

For all single-phase and three-phase 480-volt services with self-contained metering, a non-fused disconnecting means is required on the source side of the meter socket. (If the fault current is greater than 10 kA, a fused disconnect is permitted.) The disconnecting means shall be installed, owned, and maintained by the customer. The disconnecting means shall have provisions for a Company meter seal and/or padlock. Refer to Exhibit 15 for details.

For 480-volt multiple metering units (i.e., gang sockets), a disconnecting means is required on the source side of each socket as specified above for single meter installations. This requirement also applies to 480-volt multiple metering units having a main disconnect. Refer to Exhibit 16 for details.

The customer shall contact the Company's Metering Services Section during the electrical design stage to discuss the 480-volt meter disconnect requirements and to obtain approval for the proposed installation.

## **8.0 CUSTOMER EQUIPMENT**

### **8.1 Motors (Inrush Limitations & Motor Protection)**

#### Single-Phase Motors

1. All single-phase motors with ratings of one hp and larger should be connected for supply at 240 volts whenever it is practical, to minimize voltage fluctuation in the wiring system. Where service is supplied from a 208Y/120-volt system, these motors should be purchased for operation at 208 volts.
2. Motor installations for air conditioning equipment, farm applications, and heat pumps in ratings of one to seven and one-half (7-1/2) hp should be of the capacitor start-capacitor run design. The Company shall be notified of each installation of five hp or more. In

addition, the customer shall notify the Company before installing central air conditioning or heat pumps.

3. Overload protection shall be provided for all motor circuits in accordance with NEC requirements.
4. The use of automatic time-delay circuit breakers for circuit protection is strongly recommended and where fuses are used, they should always be of the time-delay type. In many instances, this time-delay will prevent unnecessary shutdowns due to the tripping of an instantaneous type of circuit breaker or blowing of ordinary short-time fuses by large currents resulting from motor starting, temporary overloads, or temporary low-voltage conditions.

#### Three-Phase Motors

1. Before any three-phase motors are installed, the Company shall be consulted to determine the character and adequacy of the available service.
2. The customer shall provide nameplate information for all motors 10 hp or greater to the Company. The Company will provide the maximum permissible inrush current for the location and for the conditions of that installation.
3. The use of reverse phase relays, phase failure relays, and low voltage relays, preferably of the adjustable time-delay type, with circuit breakers or equivalent devices, is highly recommended. These devices are desirable to disconnect motors automatically that cannot be safely reversed or would be damaged by a phase or voltage failure. Such devices shall be furnished, installed, and maintained by the customer at the customer's expense (refer to Section 8.8).

#### Starting Currents – General

1. Motor starts can produce voltage fluctuations resulting in objectionable flicker on lighting supplied by the same or nearby circuits.
2. Starting of large three-phase motors and operation of furnaces and welders requires special consideration of the power supply and wiring. The Company may assist the customer in planning these installations; and in every case, the Company shall be notified so that adequacy of the service facilities may be determined, and changes may be made if necessary.

#### Starting Currents - Frequently Started Motors

Frequently started (i.e., more than four starts per hour) single-phase motors for general use, such as for refrigerators, oil burners, water pumps, and similar devices, should have a locked rotor current not exceeding 20 amperes for operation at 120 volts and 25 amperes for operation at 240 volts. These motors are permissible on the system.

#### Starting Currents - Intermittent Started Motors

1. Single-phase motors for installations such as heat pumps, central air conditioners, grain dryers, etc., with locked rotor currents not exceeding 175 amperes served at nominal 120/240 volts or networks at 120/208Y volts, may be connected to the single-phase service furnished through one meter.
2. Motors that have starting currents exceeding the limits stated in "Starting Currents - Frequently Started Motors" and in item (1.) of Intermittent Started Motors above shall not be installed without the consent of the Company.

3. The maximum permissible motor starting currents, as indicated in item (5.) below, shall apply to the application of manually or infrequently started motors. These values are based on not more than four starts per hour with prolonged periods of continuous operation under maximum load conditions.
4. Where equipment ratings or inrush characteristics other than those covered in this section are being considered, the Company shall be consulted. The starting currents permitted will depend upon the frequency of start of the motor, the size, and character of the customer's load, and the capacity of the Company's system in the area. The maximum allowable starting current will be that value which in the Company's opinion can be supplied without causing undue interference with service to other customers.
5. Maximum Permissible Motor Starting Currents
  - a. Equipment with motors rated in horsepower (hp):

<b><u>Equipment Rated at:</u></b>	<b><u>Total Locked Rotor Current not to Exceed:</u></b>
120 volts, single-phase	50 amps
<b><u>208 or 240 volts, single-phase</u></b>	
2 hp or less	60 amps
2 hp to 6.5 hp	60 amps plus 20 amps/hp over 2 hp
Over 6.5 hp	Consult the Company
<b><u>208 or 240 volts, three-phase</u></b>	
2 hp or less	50 amps
2 hp to 19.9 hp	50 amps plus 14 amps/ hp over 2 hp
Over 19.9 hp	Consult the Company

- b. Room and unitary air conditioning or heat pump equipment rated in Btu per hour (Btu/h).  
Note: 12,000 Btu/h equals one ton.

<b><u>Equipment Rated at:</u></b>	<b><u>Total Locked Rotor Current not to Exceed:</u></b>
120 volts, single-phase	50 amps
<b><u>208 or 240 volts, single-phase</u></b>	
20,000 Btu/h or less	60 amps
20,000 Btu/h to 43,333 Btu/h	60 amps plus 3 amps/1000 Btu/h in excess of 20,000 Btu/h
Over 43,333 Btu/h	Consult the Company
<b><u>208 or 240 volts, three-phase</u></b>	
20,000 Btu/h or less	50 amps
20,000 Btu/h to 50,000 Btu/h	50 amps plus 2.5 amps/1000 Btu/h in excess of 20,000 Btu/h
Over 50,000 Btu/h	Consult the Company

6. Definitions & Notes for Motor Starting Requirements
  - a. Total locked rotor current is defined as the steady state current taken from the supply line with the motor rotor or rotors locked, with all other power-consuming components including a current-reducing starter if used connected in the starting position, and with rated voltage and frequency applied.
  - b. Where the equipment contains more than one motor and some motors are arranged for sequence starting, locked rotor current applies to that, combination of power-consuming components simultaneously started that produces a higher draw of starting current than any other combination. In such sequence arrangements, the subsequent motor(s) shall

not be started for a minimum of 1/2 second after the preceding motor(s) have completed their starting mode.

- c. Where the design of the equipment is such that unequal currents appear in the supply wires (i.e., auxiliary motors on single-phase equipment or single-phase auxiliary motors on three-phase equipment), locked rotor current applies to the supply wire carrying the largest current.
- d. For three-phase motors and equipment rated at voltages other than 240 volts, the locked rotor currents specified shall be multiplied by the inverse ratio of the voltages [For example, for a 480-volt motor, the locked rotor current would be the value in the table in item (5) above multiplied times the ratio 240/480 (0.5)].

## **8.2 Power Factor**

It is desirable to maintain the power factor of any load as near to unity as possible.

The Company shall not be obligated to furnish service when the power factor is not maintained at or above the level specified in the Tariff. In general, the customer power factor shall be between 85 percent (lagging) and 99 percent (leading) at the customer's peak load. If power factor corrective equipment is necessary, it, together with required switching equipment, shall be provided and maintained by the customer at the customer's expense.

In general, capacitors shall be applied more carefully than most types of electrical equipment in order that satisfactory operation and maintenance will result. The customer should consult with the Company before any installations of this type of equipment are made.

## **8.3 Welders & Industrial Furnaces**

The Company may assist its customers in planning installations of electric welders and industrial type furnaces. To have ample time to determine the electrical supply requirements, the customer shall consult the Company when such installations are being planned and before the customer commits to the purchase of the equipment.

## **8.4 Electrical Cooking, Space Heating, Water Heating, Ice / Snow Melting, & Electric Vehicle Charging**

In some instances, installations of electrical cooking, space heating, water heating (including tank-less), ice and snow melting, electric vehicle charging, and similar equipment require additional service capacities for satisfactory operation. The customer shall contact the Company before any such installations are made. The customer shall contact the Company before installing water heating (including tank-less) more than a total of 5,500 watts.

## **8.5 Low-Voltage Surge Arresters (600 Volts or Less)**

When low-voltage surge arresters are installed by the customer, they shall not be connected to the service drop conductors, to the service entrance conductors, or installed in the meter socket. Where installed to protect utilization equipment, low-voltage surge arresters may be either inside or outside the enclosure containing the equipment to be protected or installed at the service equipment. These arresters should never be considered as taking the place of the bond between the neutral or grounded conductor and the metallic systems at ground potential such as: metallic siding, water, waste lines, central heating, television towers and antennas, and sometimes lightning rods, but only as devices which may help to reduce appliance failures.

## **8.6 UPS, Cogeneration, Back-up Generation, & Interconnected Generation**

The customer shall consult with the Company before considering or commencing design of any back up power supply or generation (e.g., UPS, cogeneration, back-up generator, or

interconnected generation system), due to the potential safety hazard involved. In addition, if generation can run in parallel with the Company supply system, the customer shall obtain additional information on interconnection requirements from the Company's local Engineering Services Section. It is specifically prohibited to operate generation in parallel with Company facilities unless the Company has approved the interconnection design.

When installing emergency generators, customers shall employ a switch that will prevent electrical backfeed onto Company facilities when the generator is in operation.

Retail Interconnection applies to current retail customers who add generation to their side of the utility meter and interconnect to the electric grid to reduce the energy delivered by their electric utility. Retail interconnections are governed by the rules and regulations identified in the retail service Tariffs, which are filed with and approved by the State's regulatory commission. Additional information on interconnected generation can be found at [www.firstenergycorp.com](http://www.firstenergycorp.com). Then choose the appropriate Company link from the drop-down menu at the top of the page, and then click on "*Generator Interconnection Process*" under "*General Information*."

### **8.7 Harmonic Producing Equipment**

Customers shall meet the requirements of IEEE Standard 519 Section 10, Recommended Practices for Individual Customers. Typical examples of harmonic producing equipment are rectifiers, Silicon-Controlled Rectifier (SCR) drives, power supplies, inverters, arc-furnaces, welders, etc.

### **8.8 Protective Devices**

When requested, the Company shall provide the necessary information regarding the required interrupting capacity of protective devices to be installed at the customer's point of service. Where service is supplied from high short-circuit current systems, special power fuses, or breakers of high interrupting capacity shall be used. This is important to determine where protective devices are to be installed in underground secondary network Central Business District. While the Company will endeavor, where possible, to anticipate system changes, which may affect these values, the Company does not assume responsibility or liability with respect to such protective devices, nor guarantee their continuing adequacy against increased interrupting capacity requirements resulting from system changes.

The service equipment installed, irrespective of type, should be of such capacity as to permit the full utilization of the capacity of the service entrance conductors installed at the time of the original installation. Circuit breaker type service equipment is preferable in all cases, and its use is strongly recommended. However, fused type equipment is also acceptable.

Protection against loss of voltage, voltage unbalance, undervoltage transient, sustained overvoltage, phase reversal, loss of synchronism, overcurrent, short circuit, and single-phasing is highly recommended for three-phase equipment and is the responsibility of the customer. Reverse phase relays shall be provided on three-phase motors for elevators, cranes, hoists, or any other equipment requiring constant direction of rotation, where reversal of power would result in damage to the equipment or personal injury.

As indicated in Section 3.6, the Company shall not be responsible in any way for damage to the customer-owned equipment that is due to failure of the customer to provide adequate protection.

### **8.9 Special Equipment**

It is also necessary that the installation of any special equipment not covered in this section shall be referred to the Company for advice before any commitments for purchase or installation are made. Such special equipment shall include X-ray, induction and dielectric heating equipment, sign flashers, compressors or radio transmission rectifiers, and other similar devices.

## Overhead

Material	Supplied By	Installed By
Service Drop w/ connectors	Company	Company
Service Entrance (including weatherhead)	Customer	Customer
Connectors @ meter socket	Customer	Customer
Self-Contained Meter Socket 400 Amp or less	Customer	Customer
480-Volt Meter Disconnecting Means <sup>1</sup>	Customer	Customer
Current Transformer Cabinet	Customer	Customer
Current Transformers	Company	Note 5
Metering Conduit	Customer	Customer
Metering Conductors	Company	Company
Transformer Rated Meter Socket	Company	Customer
Meter	Company	Company

## Underground Service

Material	Supplied By	Installed by
Service Lateral (Cable) Residential Commercial	Company Customer	Company/Customer Customer
Trench / Base / Conduit / Backfill <sup>6</sup>	Customer	Customer
Service Entrance	Customer	Customer
Riser Pole Material Residential Commercial	Note 7 Note 8	Note 7 Note 8
Transformer Foundation Single-Phase Three-Phase	Company Customer	Note 9 Customer - Note 10
Connectors <sup>2</sup> @ Source Transformer, Pedestal, or Handhole	Company	Company
Connectors @ Meter Socket	Customer	Customer
Self-Contained Meter Socket 400 Amp or less	Customer	Customer
480-Volt Meter Disconnecting Means <sup>1</sup>	Customer	Customer
Current transformer Cabinet	Customer	Customer
Current Transformers	Company	Note 5
Metering Conduit	Customer	Customer
Metering Conductors	Company	Company
Transformer Rated Meter Socket	Company	Customer
Meter	Company	Company

### Notes:

- For all single-phase and three-phase 480-volt services with self-contained metering, a disconnect is required on the source side of the meter socket (see Exhibit 15 for details).
- For connections at pedestals, handholes, overhead transformer riser installations, and single-phase pad-mounted transformers, cable size is limited to 750 kcmil. For connections at three-phase pad-mounted transformers, cable size is limited to 16 parallel conductors of 750 kcmil per phase or 8 parallel conductors of 1000 kcmil per phase.
- The metering method for services greater than 400 amps is a current transformer cabinet or current transformers installed in the pad-mounted transformer (not approved in Met-Ed or Penn Power). Customer shall contact the Company for details.
- Customer shall contact the Company for network applications.

# Service Material Guideline for Pennsylvania Operating Companies

**FirstEnergy**

Service Guide

Rev.

1

Date

7/21

**EXHIBIT 1**



5. Current Transformers:

Company	Supplied By	Installed By
Met-Ed	Company	Customer
Penelec	Company	Company
Penn Power	Company	Customer
West Penn Power	Company	Company

6. Conduit (including elbows) is required and shall be supplied and installed by the customer.

7. Residential Riser Pole Material:

Company	Supplied By	Installed By
Met-Ed	Customer (conduit & weatherhead)	Company
Penelec	Customer (conduit & weatherhead)	Company
Penn Power	Company (U-guard)	Company
West Penn Power	Company (U-guard)	Company

8. Commercial Riser Pole Material:

Company	Supplied By	Installed By*
Met-Ed	Customer (conduit & weatherhead)	Company
Penelec	Customer (conduit & weatherhead)	Company
Penn Power	Company (U-guard)	Company
West Penn Power	Company (U-guard)	Company

\*Customer shall contact the Company for coordination of the cable pull and other riser materials.

9. Single-Phase Pad-Mounted Transformer Foundation (Box-Pad):

Company	Supplied By	Installed By
Met-Ed	Company	Company
Penelec	Company	Customer*
Penn Power	Company	Company
West Penn Power	Company	Customer

\*Customer shall contact Company for coordination.

10. Three-Phase Pad-Mounted Transformer Foundation:

Company	Supplied By	Installed By	Approved Method
Met-Ed	Customer	Customer	Box-Pad (Exhibit 25)
Penelec	Customer	Customer	Box-Pad (Exhibit 25)
Penn Power	Customer*	Customer*	Flat Pad (Exhibits 26-28)
West Penn Power	Customer	Customer	Flat Pad (Exhibits 26-28)

\* At the customer's request and expense, Penn Power may install the transformer foundation.

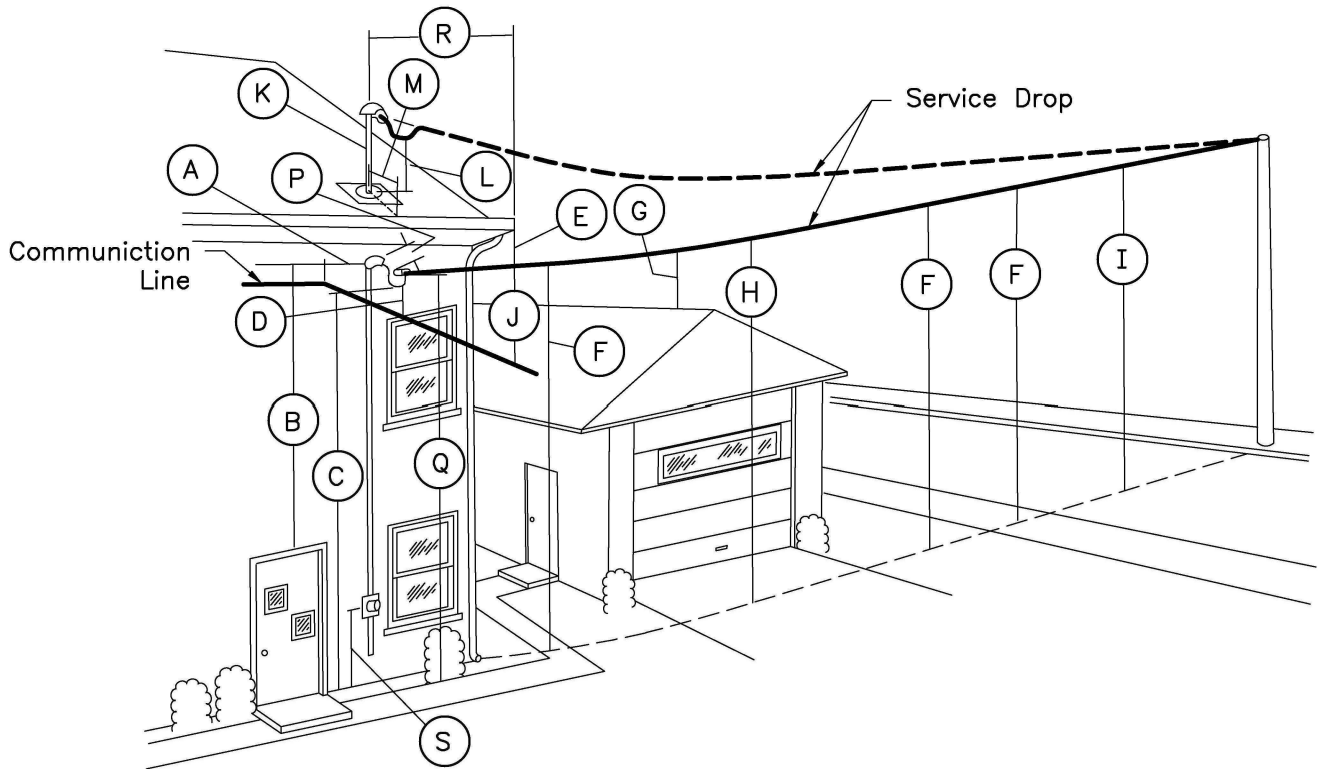

NESC/NEC Minimum Clearances

A	Communication lines (e.g., telephone, CATV) at point of attachment	1 ft
B	Doors, porches, fire escapes, and similar locations	3 ft
C	Lowest point of the drip loop: Multiplex (< 150 V to ground) Open wire (< 300 V to ground)	10 ft 12 ft
D	Windows: Beside or below Above a window	3 ft 4 inches
E	Gutters and downspouts	3 inches
F	Sidewalks and final grade: Multiplex (< 150 V to ground) Open-wire (< 300 V to ground)	12 ft 12.5 ft
G	Refer to Section 3.15 for conductors not attached to, but crossing over buildings	-
H	Residential driveways	16 ft
I	Public street, alley, public parking lot, and areas subject to truck traffic	18 ft
J	Communication line drop at crossing	2 ft
K	Optional method by use of mast: Conduit coupling shall be located near meter socket (Only power service drop conductors shall be attached to the mast.)	-
L	Overhanging roof: (Roof slope not less than 4" in 12")	18 inches 3 ft
M	Distance from service mast to edge of the roof (see dimension "L")	-
P	Point of attachment shall not be higher than the weatherhead	-
Q	Electrical service drop attachment	12 ft
R	Length of electrical service overhanging roof (see dimension "L")	-
S	Height of centerline of meter socket (approximately)	60 inches

**Notes:**

Service (including drip loop) shall be a minimum of 10 feet above decks and patios, and 3 feet above a deck railing.

**OH Service Drop Clearances  
Minimum for Services Under 600  
Volts**

**FirstEnergy.**

Service Guide	REV.
<b>EXHIBIT 2</b>	1
	DATE
	7/21

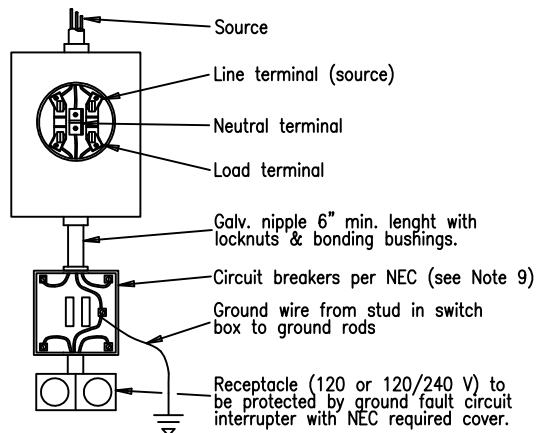
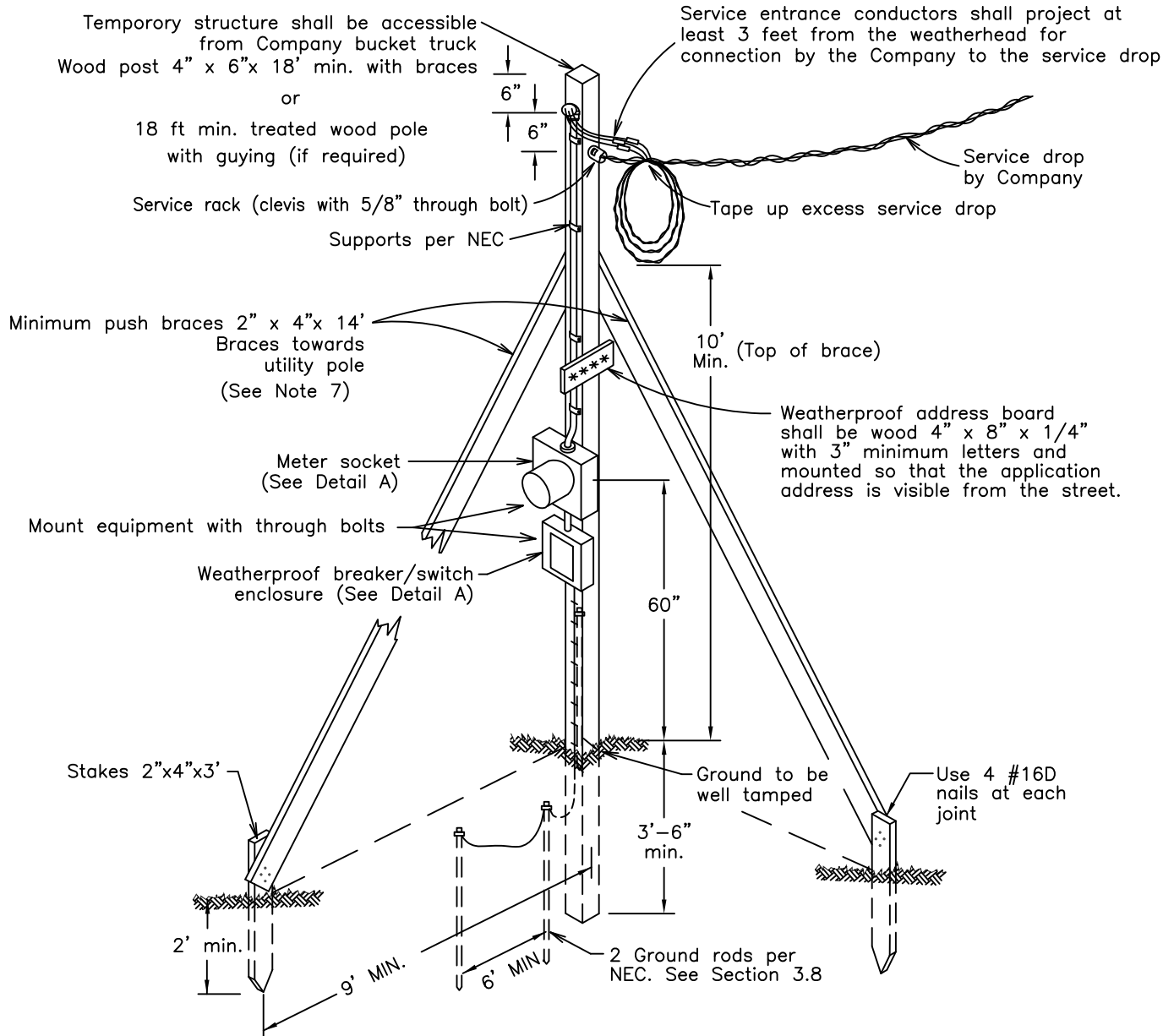

3-Wire 120/240 volt connection diagram  
Detail "A"

Notes:

1. For customer/Company responsibilities, see Exhibit 1.
2. Pole and temporary service placement shall be approved by the Company.
3. This structure is for typical temporary service of short duration only (see Section 4.0).
4. Service drop clearance above all driveways, alleys, parking lots, and areas subject to truck traffic, shall be in accordance with the NESC (see Exhibit 2). Minimum ground clearance of 10 ft to the bottom of the drip loop is required per NEC.
5. Ground fault protection shall meet NEC Article 305.
6. Company shall connect service upon receipt of fee and inspection release.
7. All wood products shall be pressure treated.
8. For installations within 30 ft of a 50 kVA or larger transformer, contact Company representative for available fault current.
9. Call state One-Call Agency 3 days before construction. Refer to Sections 3.13 & 3.14.

## Typical Temporary Service Overhead Installation

**FirstEnergy**

Service Guide	REV.
<b>EXHIBIT 3</b>	1
	DATE
	7/21

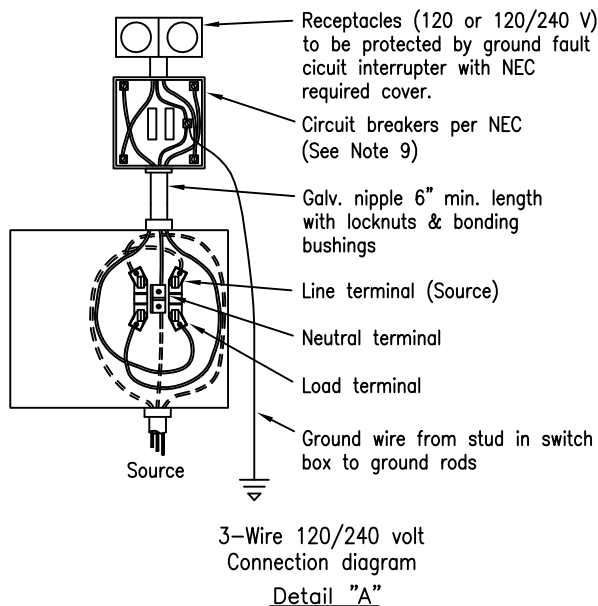
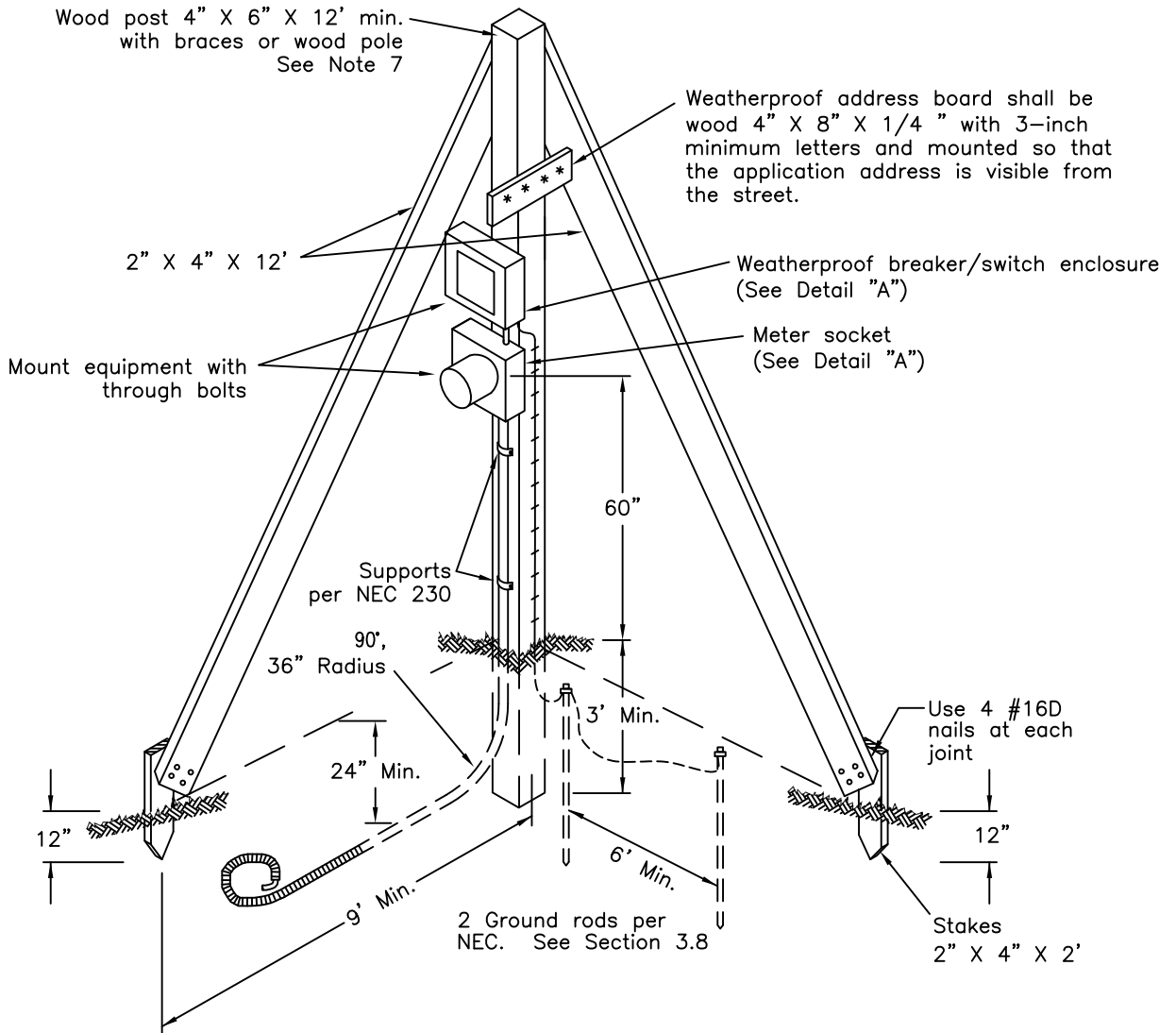

**Notes:**

1. For customer/Company responsibilities, see Exhibit 1.
2. Pole and temporary placement shall be approved by the Company.
3. This structure is for typical temporary service of short duration only (see Section 4.0).
4. Base of temporary pole shall be a minimum of 3 ft from any building foundation or permanent structure.
5. Contractor shall run service lateral cables to the Company pedestal, handhole, or transformer. Contractor to leave 5-ft coil of cable for hookup at a pedestal/handhole or 10-ft coil at a transformer. Cable shall be either 3-conductor with a ground or a 2-conductor with ground cable with the white wire permanently marked as hot per NEC 310 and 200. "Tape is not approved" for marking 2-conductor cable.
6. Ground fault protection shall meet NEC Article 305.
7. All wood products shall be pressure treated. 8. Meter socket may be connected to external ground rods, if required by local inspection authorities.
8. For installation within 30 ft of a 50 kVA or larger transformer contact Company representative for available fault current to determine breaker rating.
9. Call state One-Call agency 3 days before construction. Refer to Sections 3.13 & 3.14.

**Typical Temporary Service  
Underground Installation**

**FirstEnergy.**

Service Guide

REV.

**EXHIBIT 4**

1

DATE

7/21

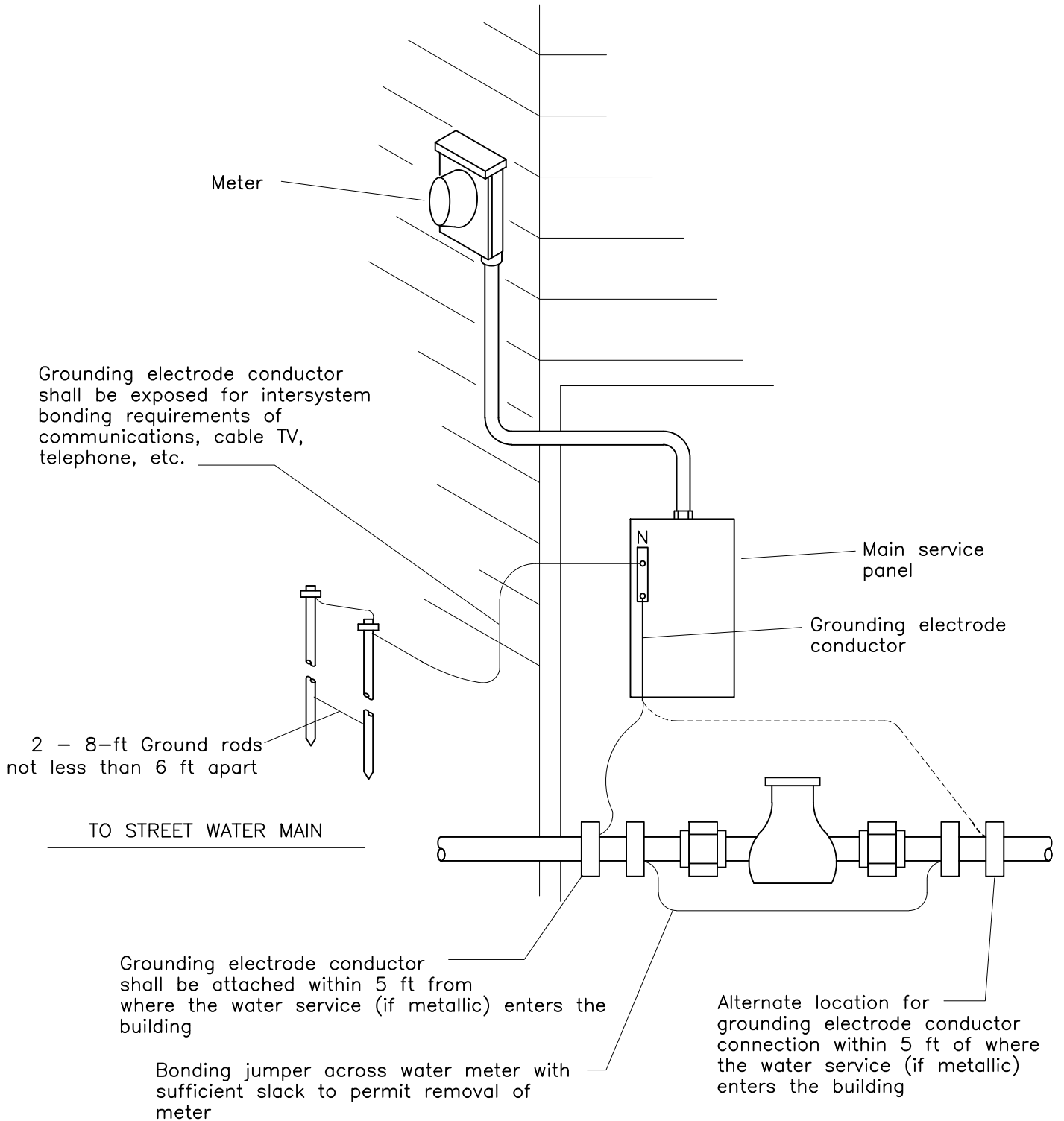

## Typical Customer Grounding Details

**FirstEnergy**

Service Guide

EXHIBIT 5

REV.

1

DATE

7/21

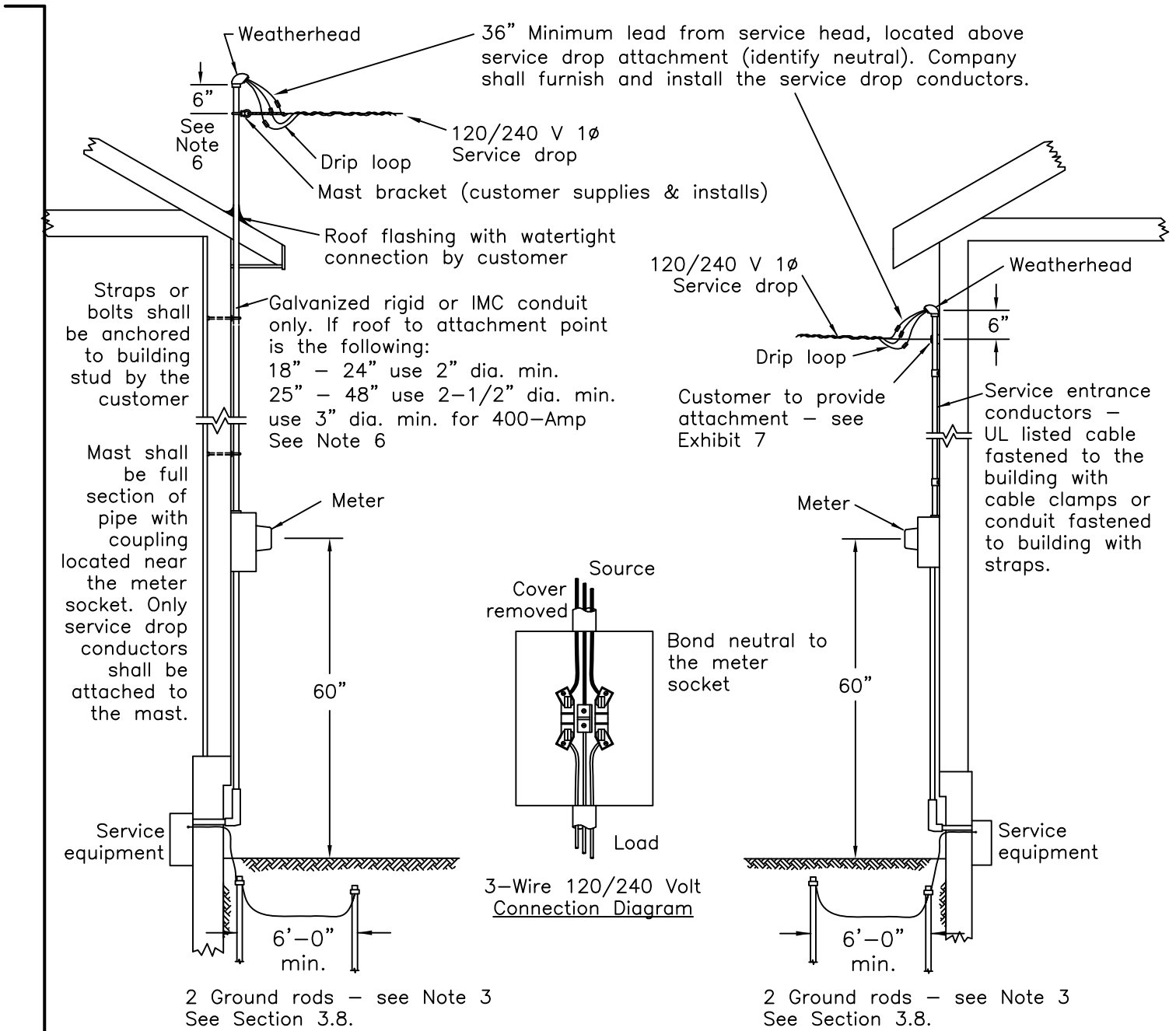

Notes:

1. For customer/Company responsibilities, see Exhibit 1.
2. Customer shall consult the Company for point of attachment and meter socket location. See Exhibit 2 for service drop clearance requirements. Connections shall be accessible from a ladder. Company personnel are not permitted to climb onto the customer's roof.
3. Two 8-ft ground rods required - spaced a minimum of 6 ft apart (see Section 3.8).
4. See Section 7.0, for meter socket details.
5. Inhibitor compound shall be used on all aluminum wire terminations.
6. Guying may be required for a service mast over 36 inches or long service drops. Customer shall contact the Company for mast heights above 48 inches.

**Typical Overhead Single-Phase Service  
 Entrance Installation  
 400 Amp or Less**

**FirstEnergy.**

Service Guide	REV. 1
<b>EXHIBIT 6</b>	DATE 7/21

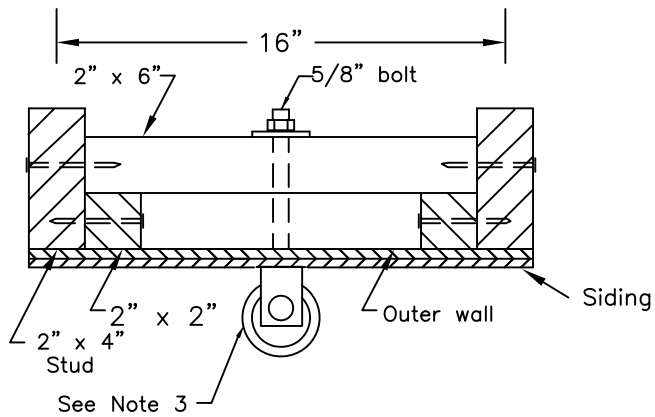

Wood, Aluminum, or Composition Siding

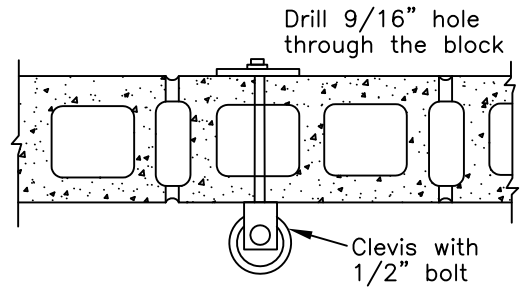

Cinder or Cement Block

To be installed in the brick or poured cement only, not in the brick mortar

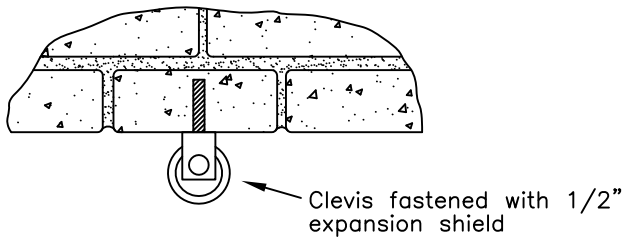

Solid Brick or Concrete Masonry

Drill 9/16" hole in stud and countersink bolt head Bolt shall be installed before brickwork is started.

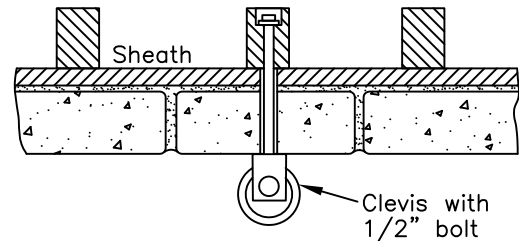

Brick Veneer

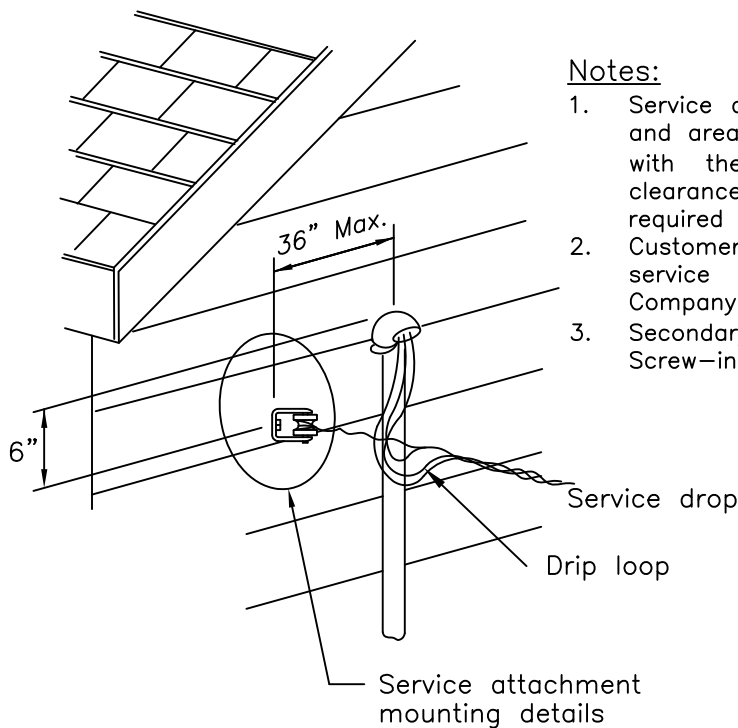

Notes:

1. Service drop clearances above grade, alleys, driveways, and areas subject to truck use, shall be in accordance with the NESC (see Exhibit 2). Minimum ground clearance of 10 feet to the bottom of the drip loop is required per NEC.
2. Customer shall provide, install, and maintain the service attachment at location approved by the Company.
3. Secondary insulators with clevis and 5/8" bolt. Screw-in type insulators are not acceptable.

**Overhead Service  
Typical Service Drop Attachment**

**FirstEnergy.**

Service Guide

REV.

1

**EXHIBIT 7**

DATE

7/21

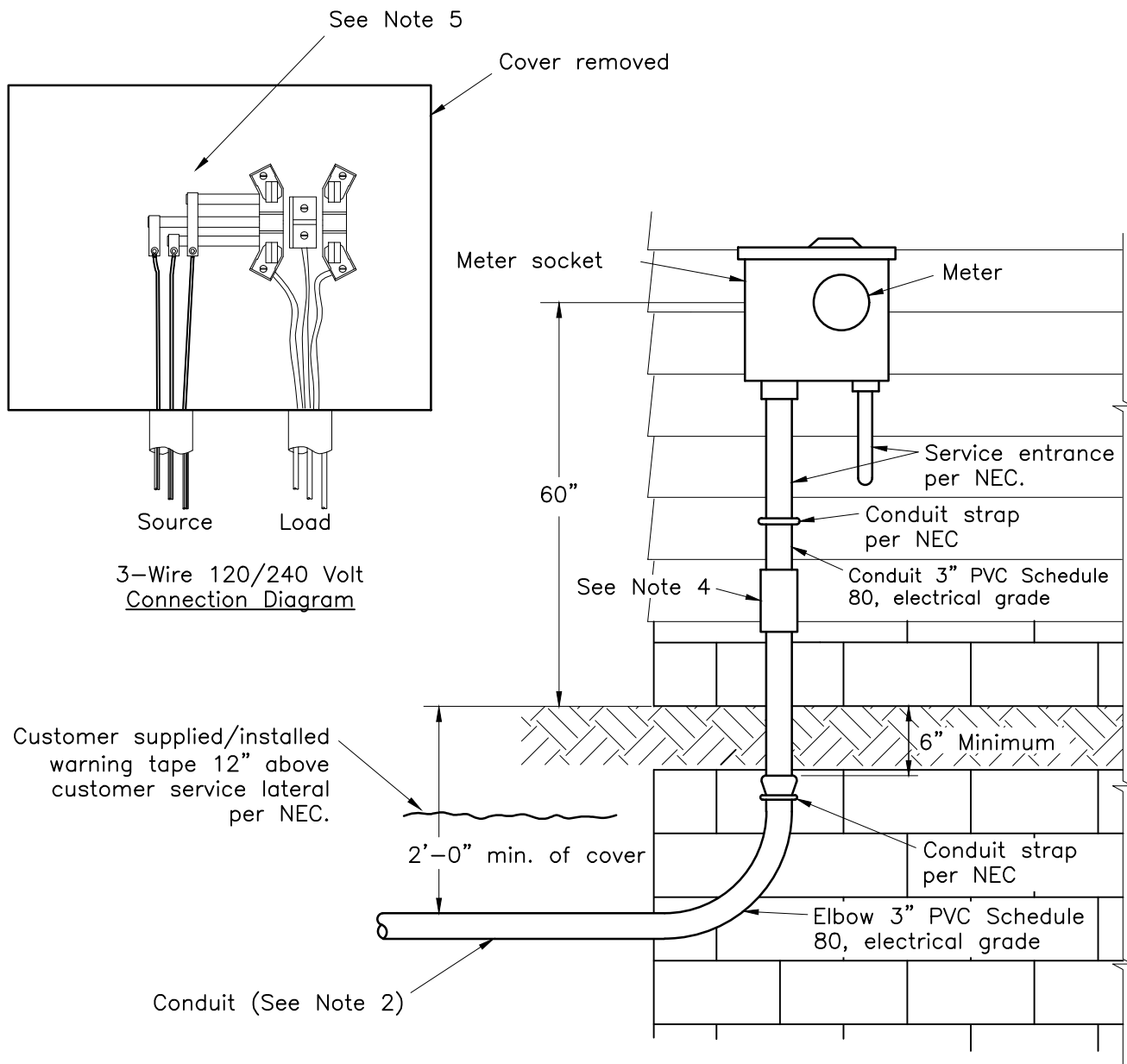

**Notes:**

1. For customer/Company responsibilities, see Exhibit 1.
2. The customer shall provide a well tamped and firm trench. For trenching and conduit details, see Exhibit 24.
3. See Section 6.0 for underground service details.
4. The customer shall provide ground movement protection per NEC 300.5(J) to prevent damage due to settlement or frost heaves. The Company recommends that the customer use a slip-joint conduit product.
5. Use side-bussed meter socket only.

**Typical Single-Phase Underground Service Lateral Installation 400 Amp or Less**

PA

**FirstEnergy**

Service Guide

REV.

1

**EXHIBIT 8**

DATE

7/21



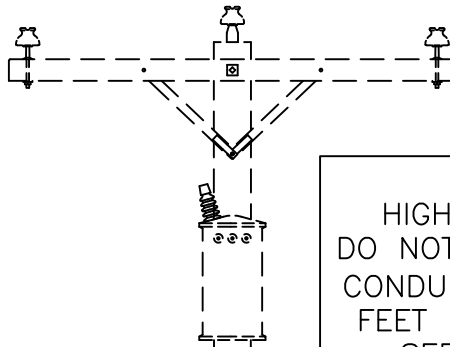

**DANGER**  
 HIGH VOLTAGE ABOVE  
 DO NOT CLIMB OR EXTEND  
 CONDUIT/WIRES ABOVE 10  
 FEET FROM GROUNDLINE  
 SEE NOTES 2 & 5

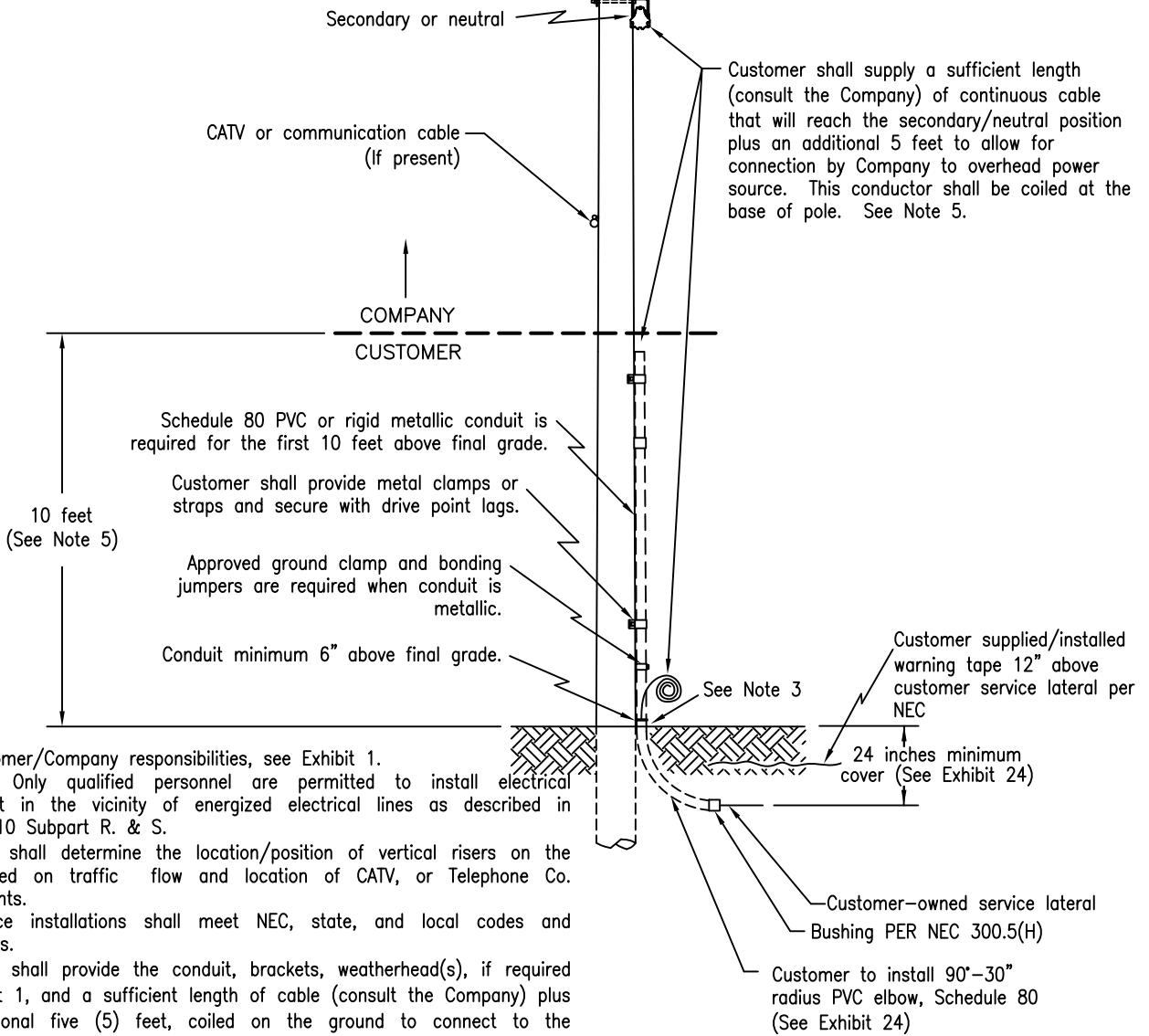

**Notes:**

1. For customer/Company responsibilities, see Exhibit 1.
2. **CAUTION:** Only qualified personnel are permitted to install electrical equipment in the vicinity of energized electrical lines as described in OSHA 1910 Subpart R. & S.
3. Company shall determine the location/position of vertical risers on the pole based on traffic flow and location of CATV, or Telephone Co. attachments.
4. All service installations shall meet NEC, state, and local codes and regulations.
5. Customer shall provide the conduit, brackets, weatherhead(s), if required by Exhibit 1, and a sufficient length of cable (consult the Company) plus an additional five (5) feet, coiled on the ground to connect to the overhead source. The first ten (10) feet of conduit shall be schedule 80 PVC or rigid metallic conduit, if required by Exhibit 1. Company will complete the installation. Customer shall coordinate the installation with the Company.
6. Conduit size limited to 4" dia. conduit size. For conduit diameter greater than 4". See Exhibit 10A.
7. Penn Power customers shall contact Engineering.

**Direct Attachment of Customer-Owned Underground  
 Secondary Service Lateral(s) on Pennsylvania Operating  
 Company's Poles**

**FirstEnergy.**

Service Guide	REV.
<b>EXHIBIT 9</b>	1
	DATE
	7/21

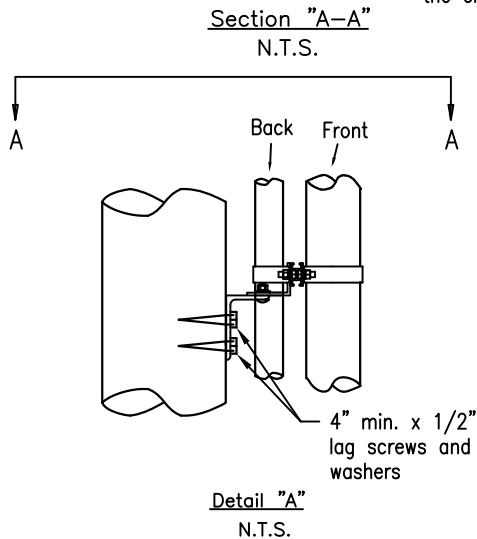
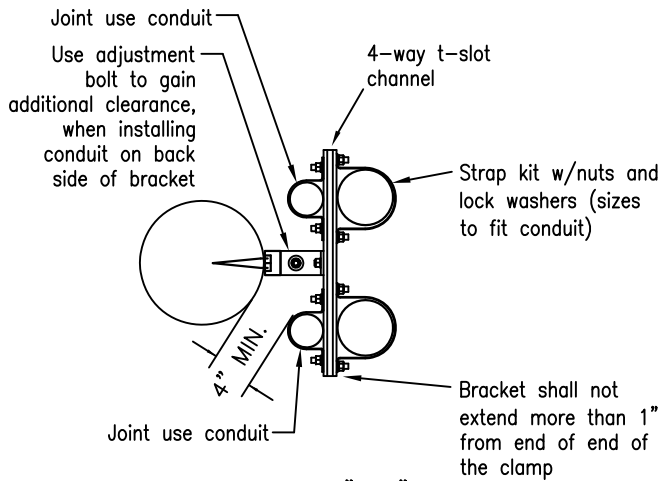

**MANUFACTURED ASSEMBLY**  
(to be supplied by customer, installed by Company - See Note 1)

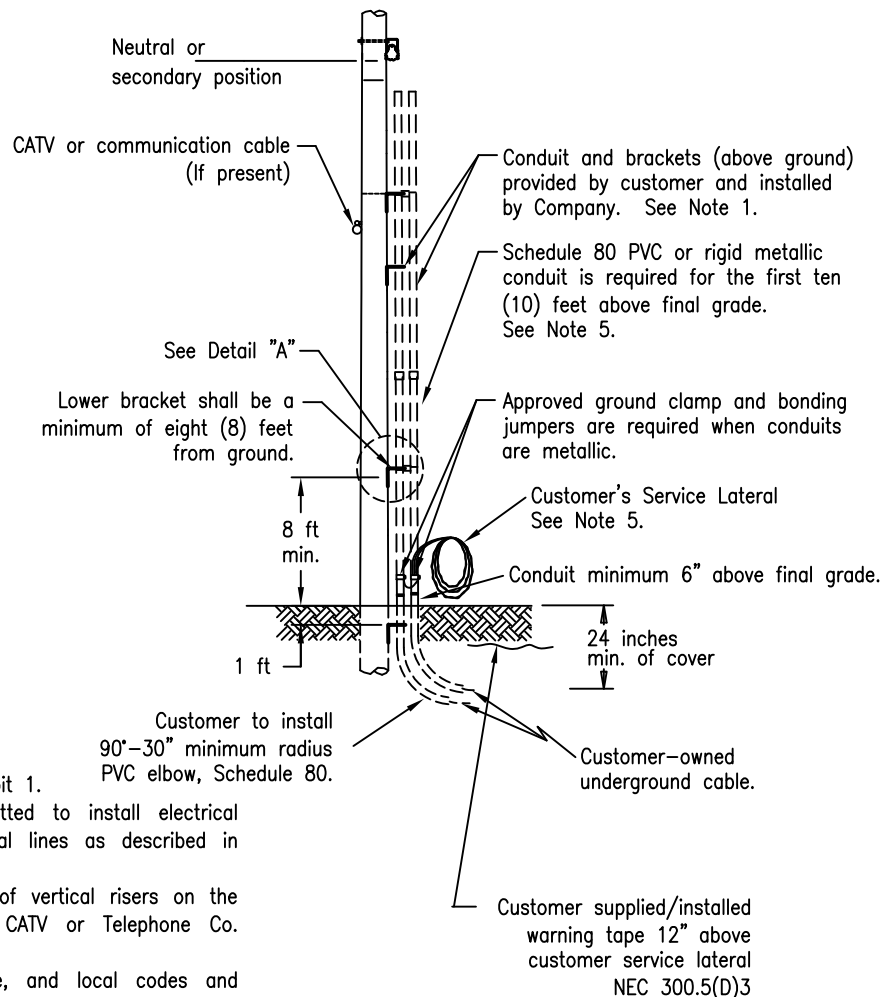

**Notes:**

- For customer/Company responsibilities, see Exhibit 1.
- CAUTION:** Only qualified personnel are permitted to install electrical equipment in the vicinity of energized electrical lines as described in OSHA 1910 Subpart R. & S.
- Company shall determine the location/position of vertical risers on the pole based on traffic flow and location of CATV or Telephone Co. attachments.
- All service installations shall meet NEC, state, and local codes and regulations.
- Customer shall provide the conduit, brackets, weatherhead(s), if required by Exhibit 1, and a sufficient length of cable (consult the Company) plus an additional five (5) feet, coiled on the ground to connect to the overhead source. The first ten (10) feet of conduit shall be schedule 80 PVC or rigid metallic conduit, if required by Exhibit 1. Company will complete the installation. Customer shall coordinate installation with the Company.
- Penn Power customers shall contact Engineering.

**Standoff Attachment of Customer Underground Secondary Service Lateral(s) on Pennsylvania Operating Company's Pole**

**FirstEnergy.**

Service Guide	REV.
EXHIBIT 10A	1
	DATE
	7/21

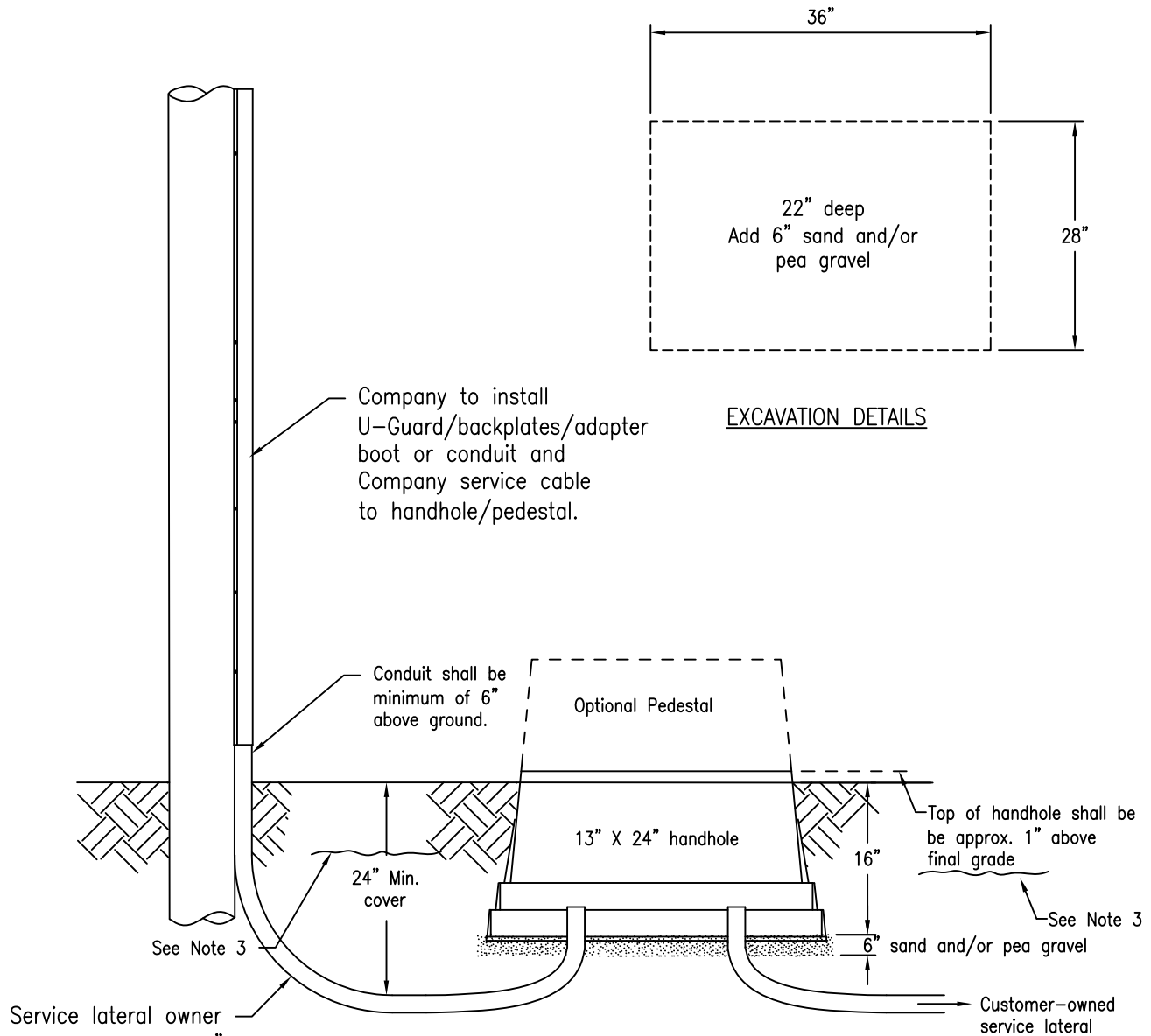

**The use of this Exhibit requires Company approval.**

Notes:

1. For customer/Company responsibilities, see Exhibit 1.
2. Customer to excavate for handhole and provide and install conduit on line-side of the handhole. Company to provide and install handhole and make connections to customer's service lateral conductors.
3. Customer supplied/installed red electrical warning tape 12" above buried conduit per NEC.
4. Customer-owned cables shall not be located in the road right-of-way.

**Customer-Owned Underground  
Secondary Service Lateral to  
Handhole / Pedestal**

**FirstEnergy.**

Service Guide	REV.
	0
<b>EXHIBIT 10B</b>	DATE
	7/21

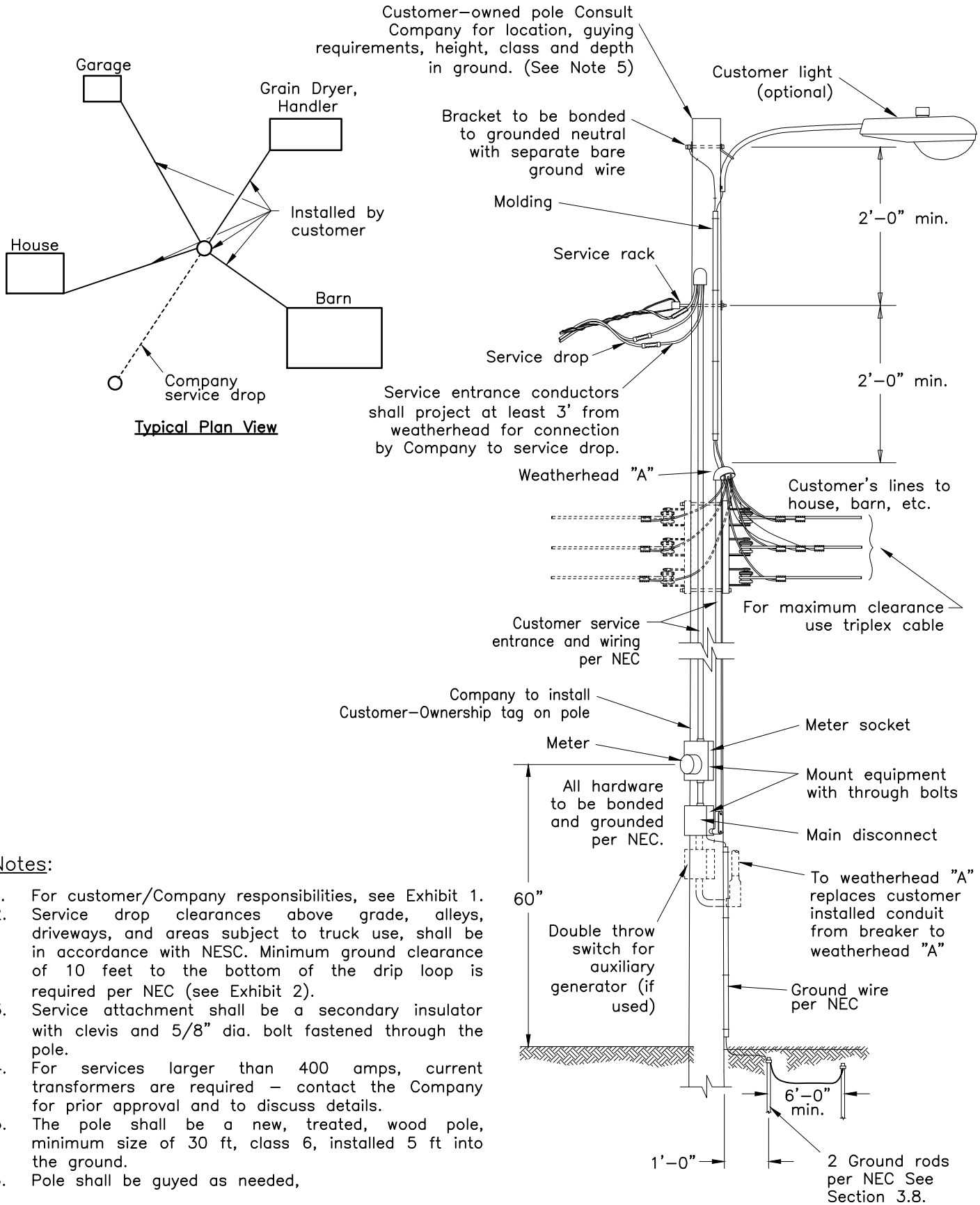

**Notes:**

1. For customer/Company responsibilities, see Exhibit 1.
2. Service drop clearances above grade, alleys, driveways, and areas subject to truck use, shall be in accordance with NESC. Minimum ground clearance of 10 feet to the bottom of the drip loop is required per NEC (see Exhibit 2).
3. Service attachment shall be a secondary insulator with clevis and 5/8" dia. bolt fastened through the pole.
4. For services larger than 400 amps, current transformers are required – contact the Company for prior approval and to discuss details.
5. The pole shall be a new, treated, wood pole, minimum size of 30 ft, class 6, installed 5 ft into the ground.
6. Pole shall be guyed as needed,

**Typical Overhead Service  
Central Distribution Installation**

**FirstEnergy**

Service Guide	REV.
<b>EXHIBIT 11</b>	1
	DATE
	7/21

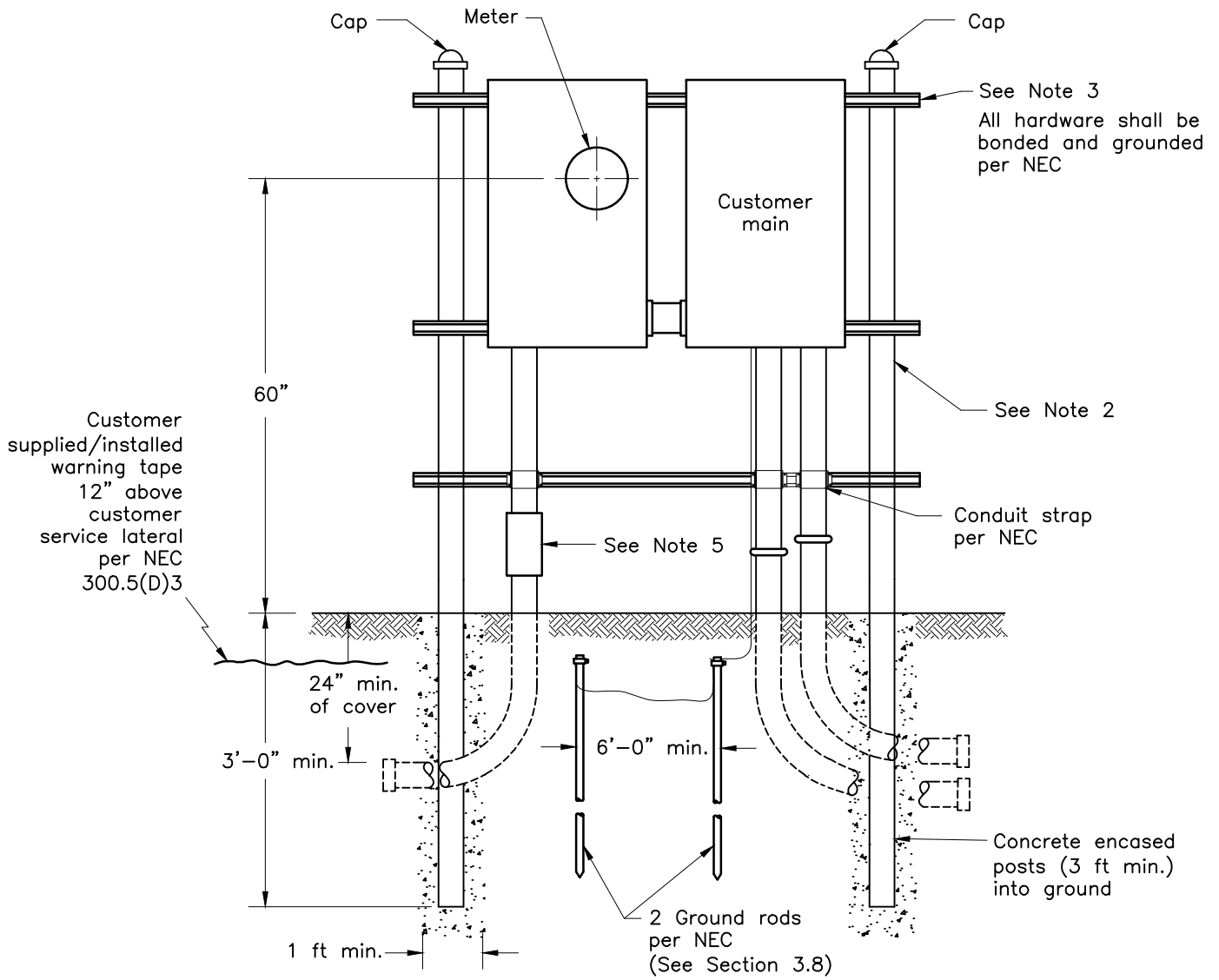

**Notes:**

1. For customer/Company responsibilities, see Exhibit 1.
2. Support post (customer-owned): use two 2-1/2" min. galvanized rigid metal conduit (RMC) – steel (min. 0.205" thick) capped and concrete encased in ground.
3. Mounting hardware: use three 12 gauge 1-5/8" x 1-5/8" continuous slot hot dipped galvanized channel (e.g., unistrut) complete with 1-1/4" x 5/16" dia. 13 thd. spring nut (2 per channel), 5/16" hex nut, and lock washer securely mounted to support posts.
4. Supply-side conduit shall be rigid galvanized or IMC steel, or Schedule 80 PVC (electrical grade).
5. The customer should ground movement protection per NEC 300.5(J) to prevent damage due to settling.
6. This Exhibit can also be used for stand-alone, self-contained metering.

**Typical Underground Service  
Central Distribution Installation  
/ Stand-Alone Metering**

**FirstEnergy**

Service Guide	REV.
EXHIBIT 12	1
	DATE
	7/21

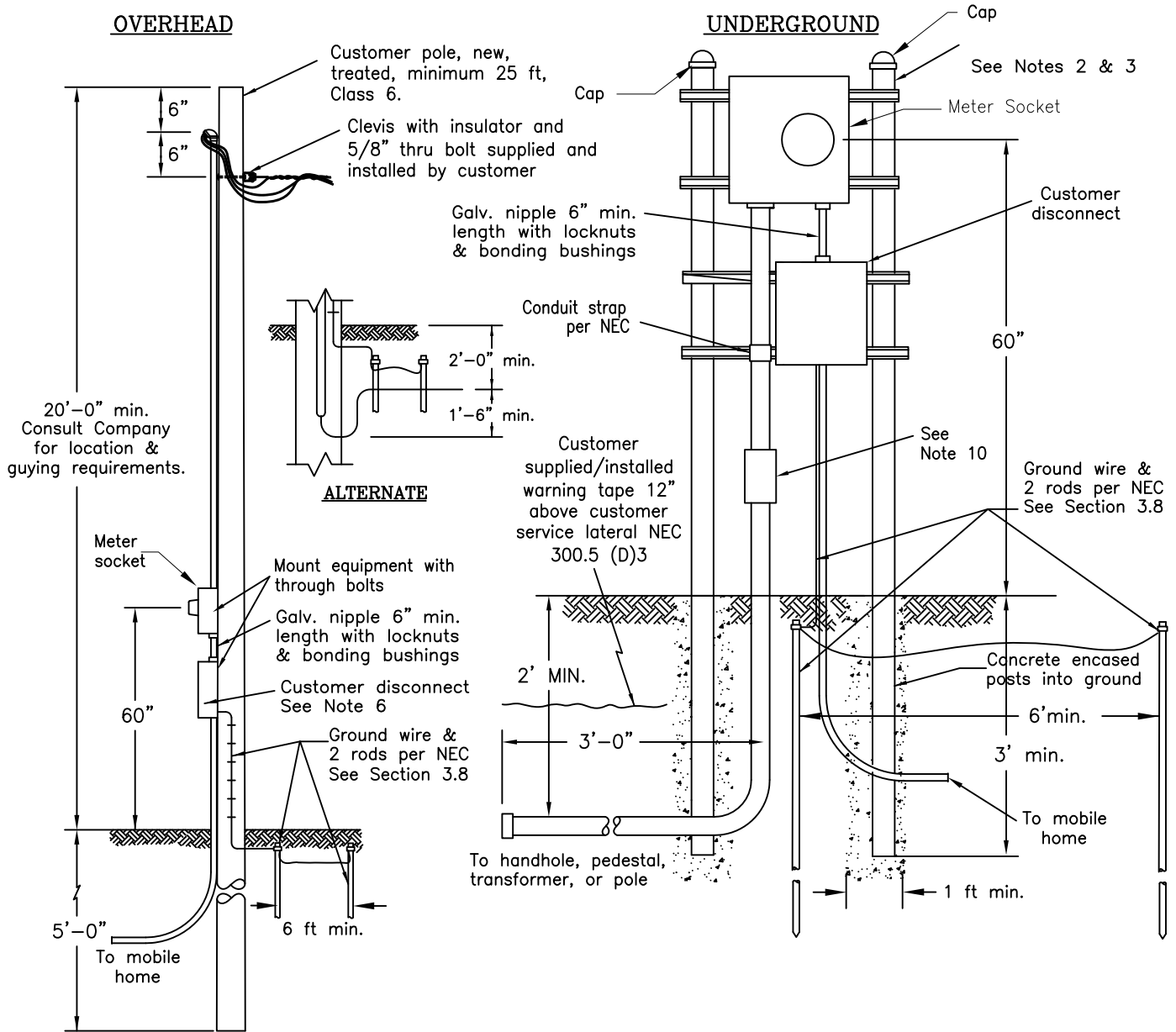

**Notes:**

1. For customer/Company responsibilities, see Exhibit 1
2. Support post (customer-owned): use two 2-1/2-inch min. galvanized rigid metal conduit (RMC) – steel (min. 0.205" thick) capped and concrete encased in ground.
3. Mounting hardware: use four 12 gauge 1-5/8" x 1-5/8" continuous slot hot dipped galvanized channels (e.g., unistrut) complete with 1-1/4" x 5/16" dia. 13 thd spring nut (2 per channel), 5/16" hex nut, and lock washer securely mounted to support posts.
4. Prefabricated meter pedestal may be substituted for 2 & 3 above. Contact regional Metering Services.
5. When using customer-owned direct burial cable, refer to the "alternate drawing."
6. Customer disconnect per NEC (located within sight of and within 30 feet of the mobile home).
7. Customer security light may be installed on the pole if a clearance of 2'-0" min. above or below the weatherhead is maintained and Company approval is obtained.
8. For identification purposes, the socket (inside & out) and breaker shall be permanently and plainly marked to designate the address number being served.
9. See trenching details Exhibit 24. Supply-side conduit shall be rigid galvanized or IMC steel, or Schedule 80 PVC (electrical grade).
10. The customer should provide ground movement protection per NEC 300.5 (J) to prevent damage from settling.

**Typical Single Mobile Home Service  
Overhead & Underground**

**FirstEnergy.**

Service Guide

REV.

1

**EXHIBIT 13**

DATE

7/21

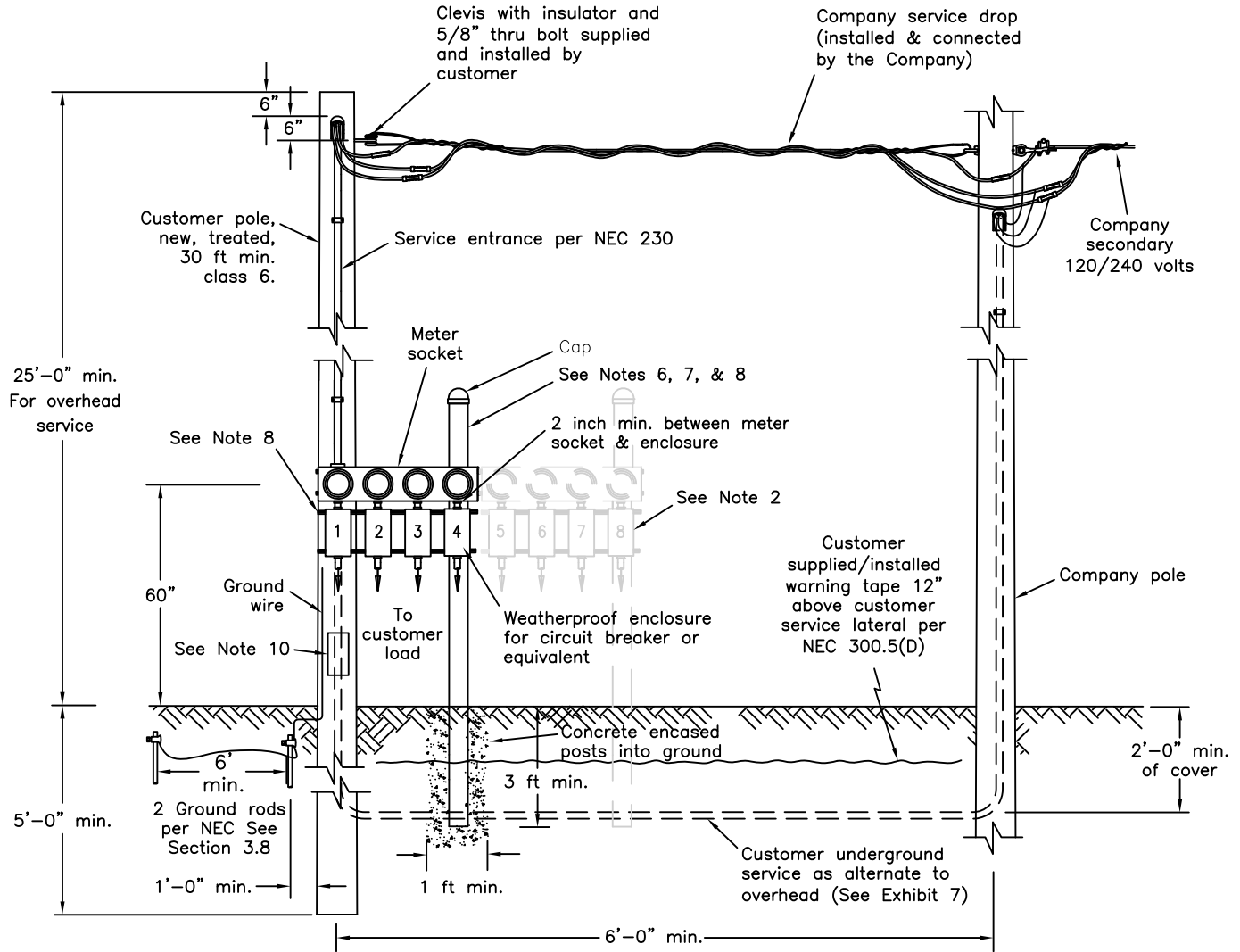

**Notes:**

1. For customer/Company responsibilities, see Exhibit 1.
2. All sockets (inside & out) and breakers shall be permanently and plainly marked to designate the particular unit served.
3. If more than six meters, a main disconnect is required (per NEC).
4. Wood poles shall be new, pressure treated, 30 ft min., Class 6 pole.
5. All hardware shall be bonded and grounded per NEC.
6. Support post (customer-owned): use 2-1/2 inch min. galvanized rigid metal conduit (RMC) steel (min. 0.205" thick) capped and concrete encased in the ground for three or more feet.
7. Mounting hardware: use four 12 gauge 1-5/8" x 1-5/8" continuous slot hot dipped galvanized channels (e.g., unistrut) complete with 1-1/4" x 5/16" dia. 13 thd. spring nut (2 per channel), 5/16" hex nut, and lock washer securely mounted to support posts. Use through bolts to mount channels to the wood pole.
8. Prefabricated meter pedestal may be substituted for 7 & 8 above. Contact regional Metering Services.
9. Supply-side conduit shall be rigid galvanized or IMC steel, or Schedule 80 PVC (electrical grade).
10. The customer should provide ground movement protection per NEC 300.5 (J) to prevent damage from settling.

**Metering & Service Facilities  
for Mobile Home & Travel Trailer Parks  
Four or More Meters**

**FirstEnergy.**

Service Guide	REV.
	1
<b>EXHIBIT 14</b>	DATE
	7/21

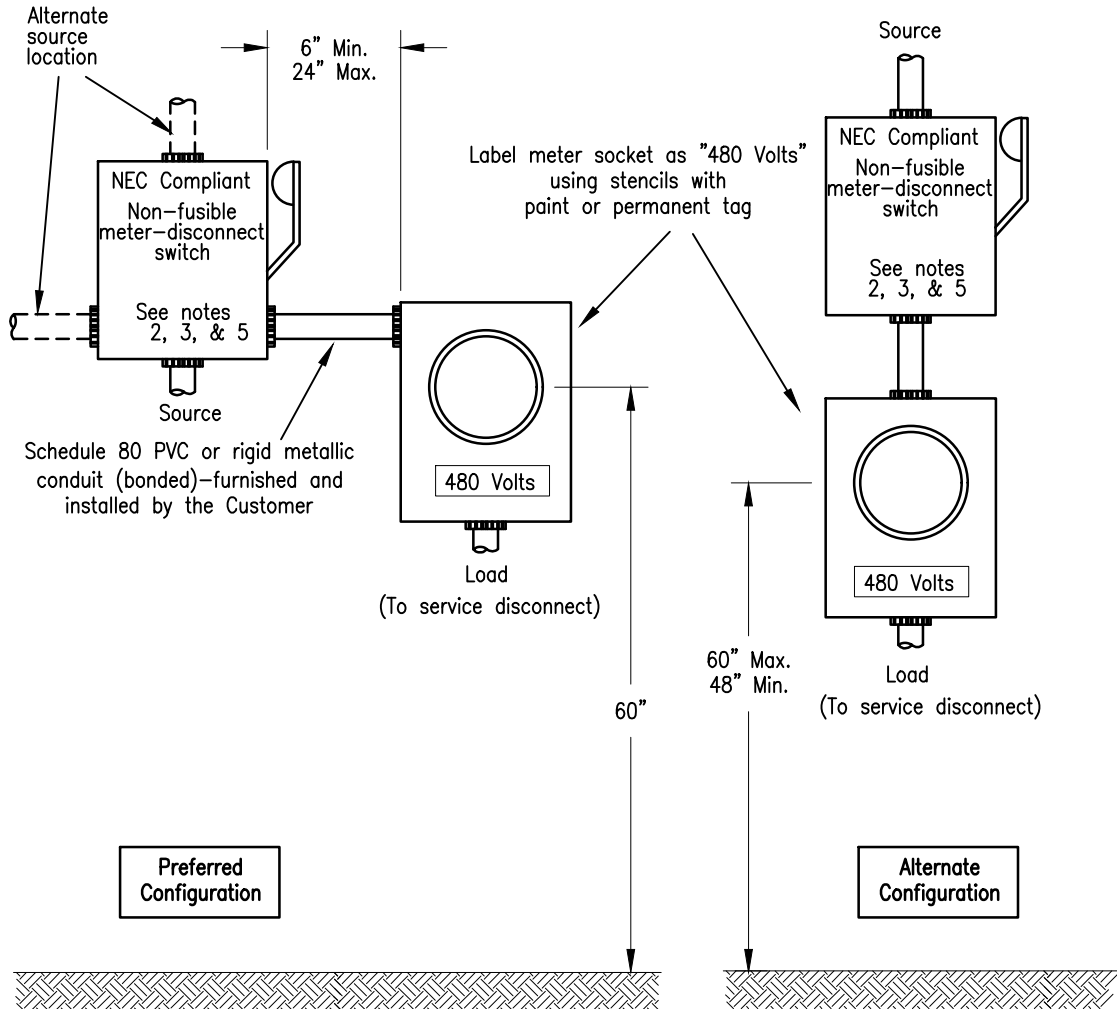

**Notes:**

1. For customer/Company responsibilities, see Exhibit 1.
2. NEC compliant non-fusible meter disconnect switch shall be supplied, installed, and maintained by the customer on the source side of the meter socket. Contact the Company's Metering Services Section for details regarding the requirements and to obtain approval for the proposed installation.
3. The non-fusible meter disconnect switch shall be lockable in the open and closed positions. The switch enclosure shall have provisions for a Company seal and/or padlock.
4. See Exhibit 16, for 480-volt gang- and multiple-socket unit installations.
5. For fault current greater than 10 kA, a fusible disconnect is permitted. Customer shall contact the Company.

**Metering Installation Single-Phase & Three-Phase 480 Volt  
Self-Contained Meter with Source-Side Disconnect  
400 Amp or Less**

**FirstEnergy**

Service Guide	REV. 1
<b>EXHIBIT 15</b>	DATE 7/21



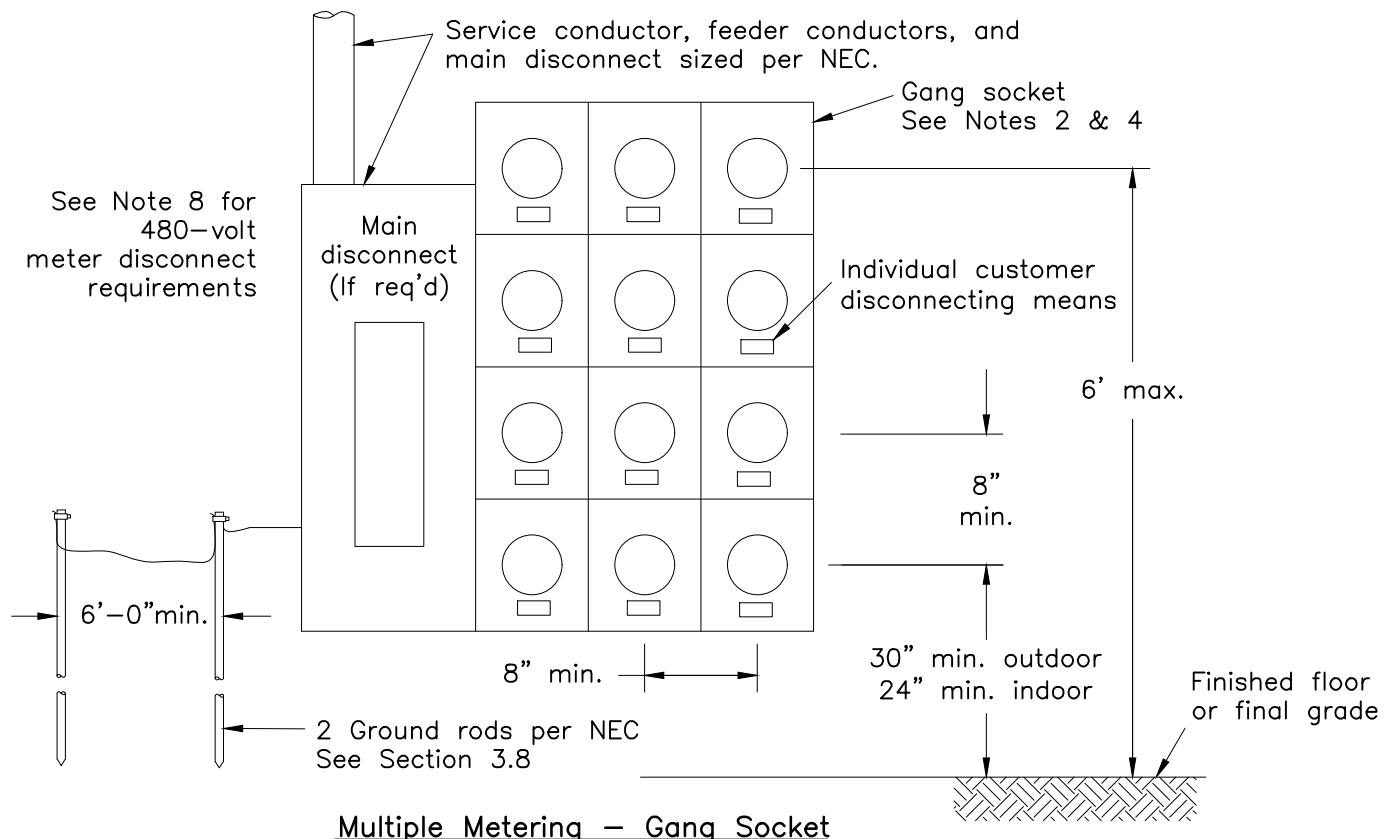

**Multiple Metering – Gang Socket**

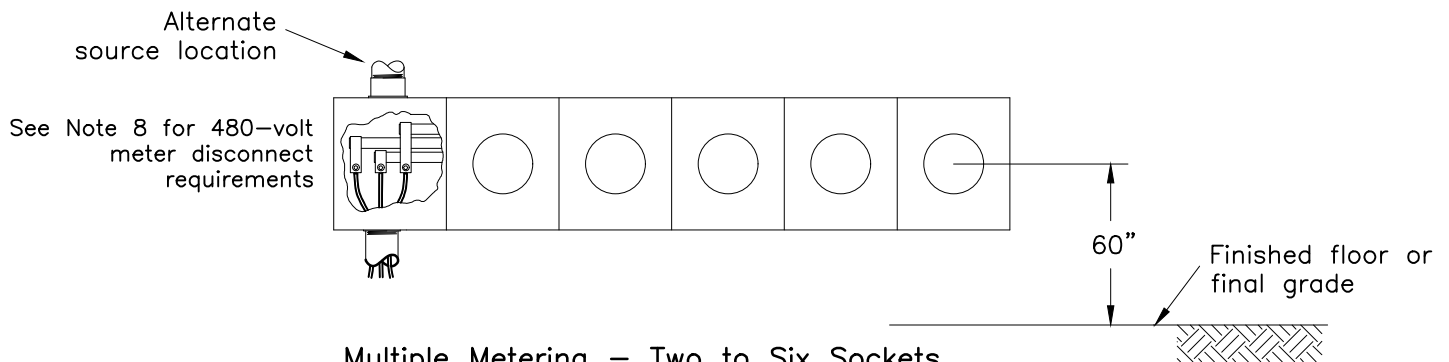

**Multiple Metering – Two to Six Sockets**

**Notes:**

1. For customer/Company responsibilities, see Exhibit 1.
2. Contact the regional Metering Services Section before installation of ganged sockets.
3. Main disconnecting means not required for six meters or less.
4. Height shall not exceed 4-meter positions.
5. All sockets (inside and out) and breakers shall be permanently and plainly marked to designate the specific unit served.
6. If installation contains poly-phase or 480-volt meter sockets, these shall be plainly marked.
7. Meter socket(s) may be connected to external ground rods, if required by the local inspection authorities.
8. For 480-Volt services, a disconnecting means is required on the source-side of each meter socket (see Exhibit 15 for details).

**Multiple Meter Installation  
Self-Contained Metering  
400 Amp or Less**

**FirstEnergy**

Service Guide	REV.
	1
<b>EXHIBIT 16</b>	DATE
	7/21

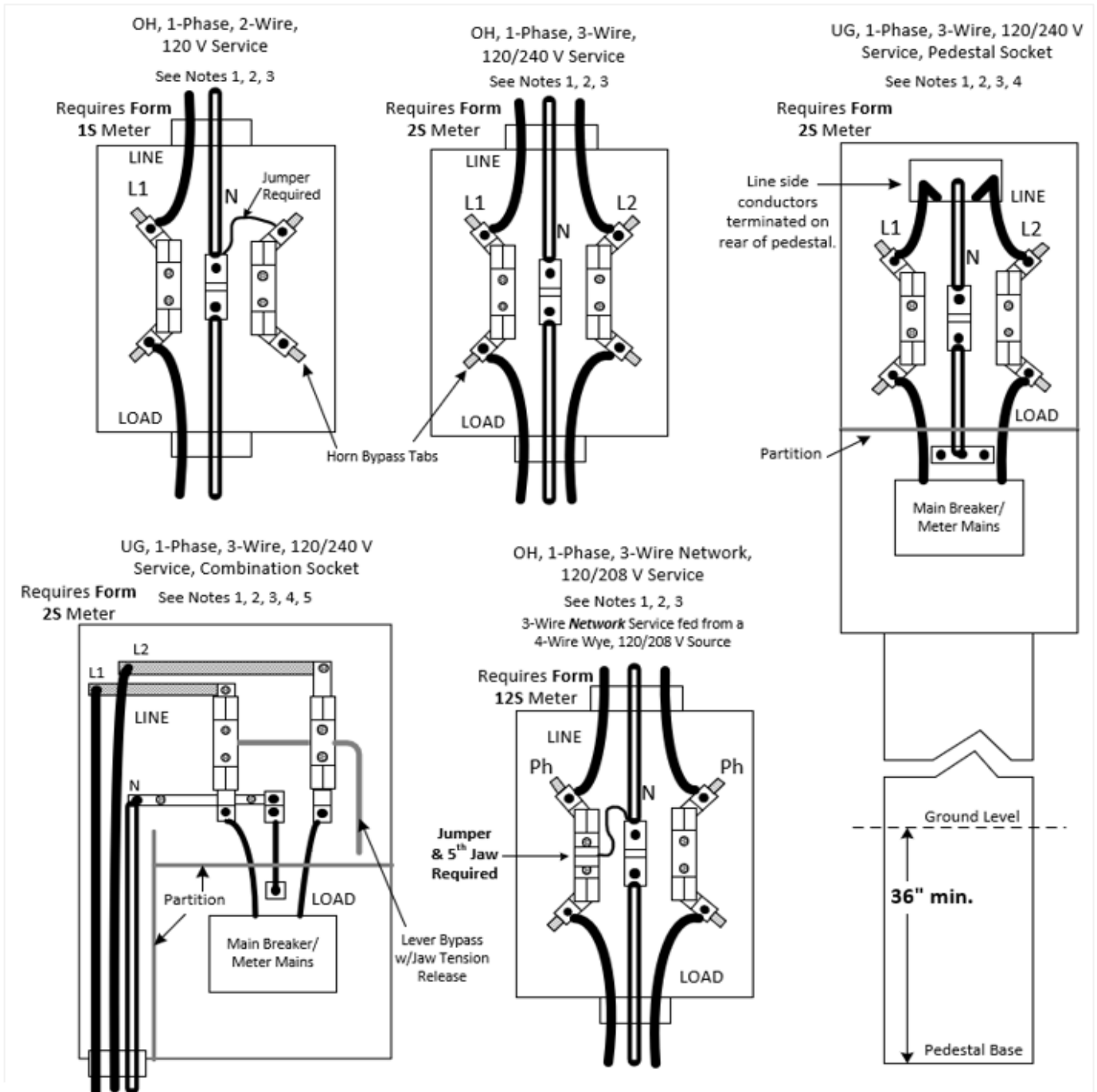

**Notes:**

- 1) See **Section 7.2** for acceptable meter socket locations. See table in **Section 7.5** for more detailed meter socket guidelines. Refer to **Exhibit 1** for customer/Company responsibilities.
- 2) Single-phase commercial sockets shall be equipped with a lever arm bypass w/jaw tension release. Sockets that are not required to have lever arm bypass are required to have horn bypasses.
- 3) Horn Bypass Tabs shall be located directly adjacent to their corresponding socket jaw.
- 4) Sockets intended for permanent UG service shall be side-bused. Sockets having down based line-side terminations are acceptable (see Combination Socket on Exhibit 18). Pedestal sockets having a line-side wireway on the back of the pedestal are not required to be side bused.
- 5) A partitioned line-side wireway shall be large enough to accommodate the largest conductor size specified. The wireway must be void of sharp edges or points.

**Metering Installation – Self-Contained  
Single-Phase 400 Amp or Less**

**FirstEnergy**

Service Guide	Rev.
	1
<b>EXHIBIT 17</b>	Date
	7/21

3-Phase, 4-Wire Services, 120/240 V Delta, 120/208 V Wye, 277/480 V Wye  
 (Connections on this page require a Form 16S meter)

OH, Socket Connections

See Notes 1, 2, 5, 6

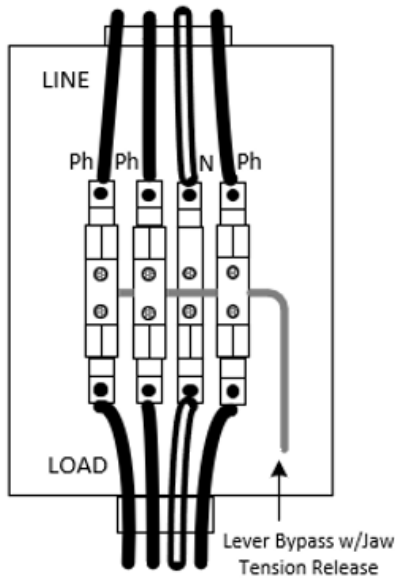

UG, Side-wired Socket Connections

See Notes 1, 2, 3, 4, 5, 6

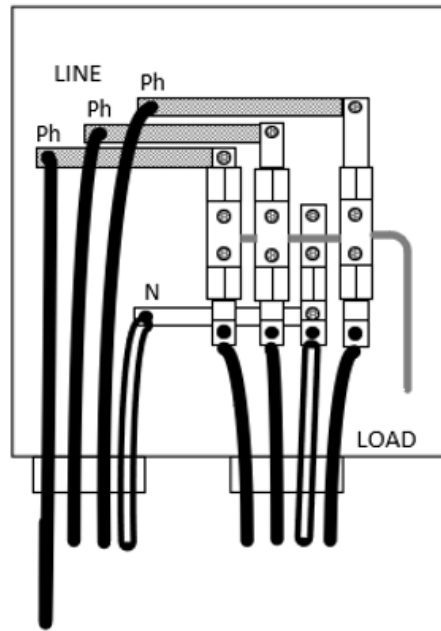

UG, Combination Socket, Down based line-side terminations, Integral breaker

See Notes 1, 2, 3, 4, 5, 6

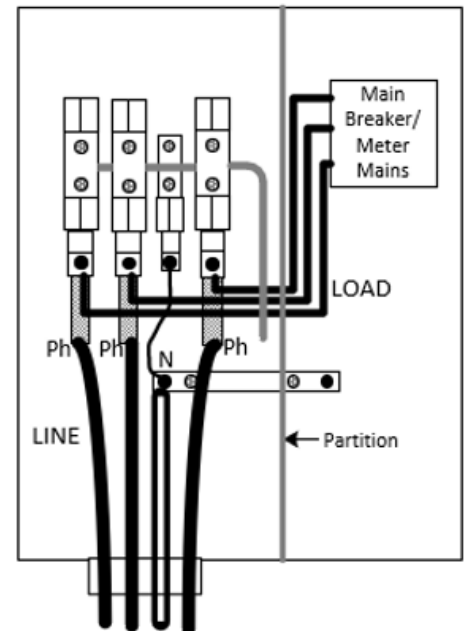

Notes:

- 1) See table in **Section 7.5** for more detailed meter socket guidelines. See **Section 7.2** for acceptable meter socket locations. Refer to **Exhibit 1** for customer/Company responsibilities.
- 2) Three-phase sockets shall be equipped with a lever arm bypass w/jaw tension release capability.
- 3) Sockets intended for UG service shall be side-bused. Sockets having down based line-side terminations are acceptable (see Combination Socket above right). Pedestal sockets having a line-side wireway on the back of the pedestal are not required to be side bused.
- 4) If socket is equipped with a partitioned line-side wireway, the wireway shall be large enough to accommodate the largest conductor size specified. The wireway must be void of sharp edges or points.
- 5) **If the service has a high leg (3-ph, 4-wire 120/240 V Delta), the high leg (208 V to GND) shall be terminated to the top right-side terminal.**
- 6) If service is 4-wire 277/480 V Wye or 3-wire 480 V, a source-side disconnect is required. See Exhibit 15 for details.

**Metering Installation – Self-Contained  
 Three-Phase 400 Amp or Less**

**FirstEnergy**

Service Guide	Rev. 1
<b>EXHIBIT 18</b>	Date 7/21

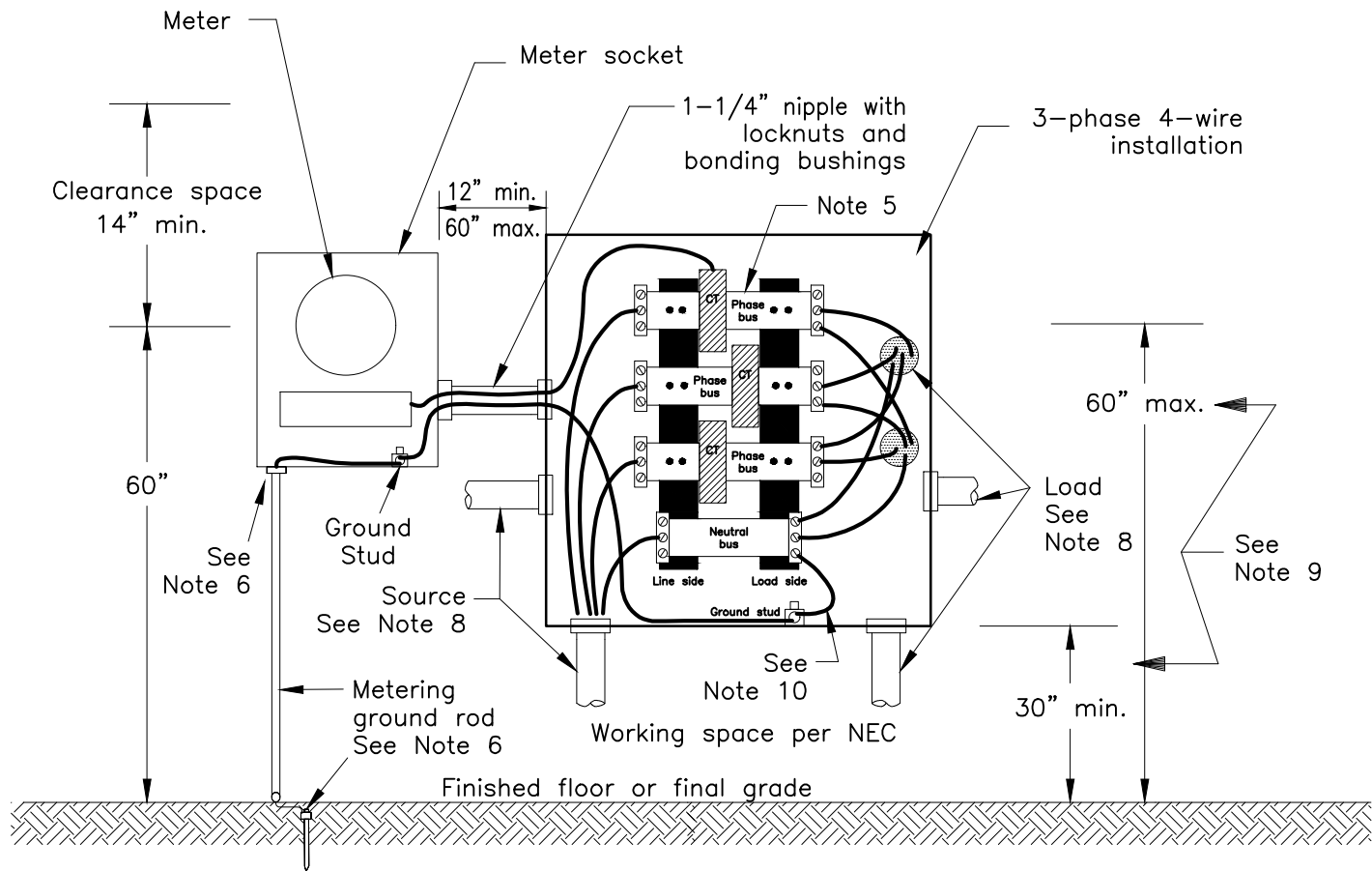

**Notes:**

1. For customer/Company responsibilities, see Exhibit 1.
2. See Section 7.10 for approved CT cabinets.
3. Customer shall provide bonding, grounding, and working space per NEC.
4. Mount H1 towards the source.
5. Arrange the bus phases 1-2-3-N top-to-bottom (shown above) or left-to-right for three-phase four-wire wye installations. For four-wire delta installations, the high leg shall be located on the top bus location and marked per NEC.
6. Customer shall furnish and install 5/8-inch x 8-foot ground rod with a #6 AWG copper ground wire connected to the meter socket ground lug. Protect the wire with non-metallic conduit.
7. Current Transformer (CT) cabinet shall be installed on the exterior building wall, unless approved by the regional Metering Services Section.
8. Conduits shall enter the CT cabinet from the side, bottom, or back. Conduits shall not enter the top of CT cabinet without obtaining Company approval.
9. The mounting height of any CT above final grade or floor shall be 30 inch min. and 60 inch max. Refer to Exhibit 20 for mounting details.
10. Neutral bus shall be bonded to ground stud in CT cabinet per NEC table 250.102(C)(1). Do not run separate grounding conductor from CT cabinet to main disconnect.

**Metering Installation Outdoor –  
Metering Cabinet with Current  
Transformers Details**

**FirstEnergy**

Service Guide	REV.
	1
<b>EXHIBIT 19</b>	DATE
	7/21

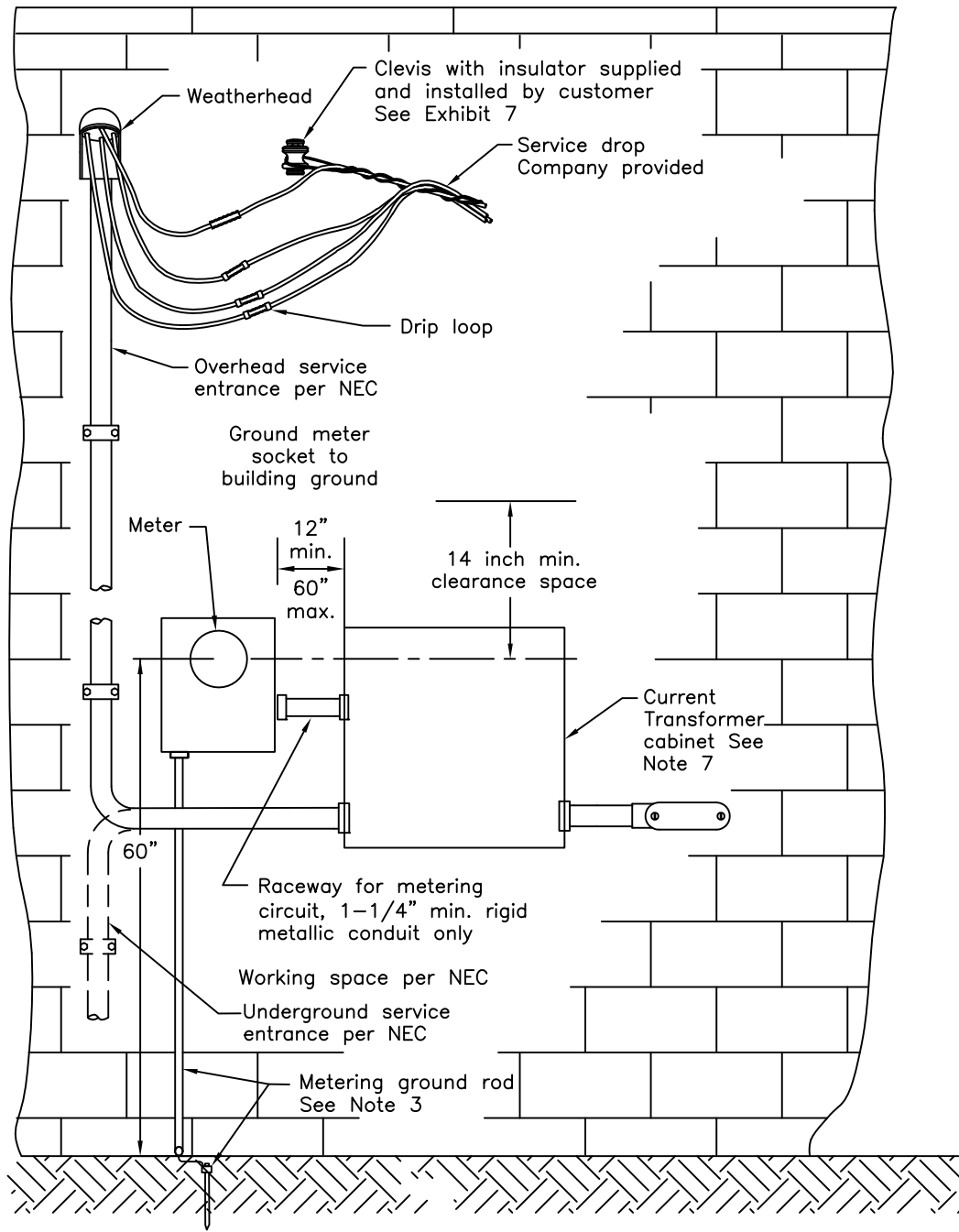

**Notes:**

1. For customer/Company responsibilities, see Exhibit 1.
2. Customer shall provide bonding, grounding, and working space per NEC.
3. Customer to furnish and install 5/8-inch diameter x 8-foot ground rod with a #6 copper ground wire connected to the meter socket ground lug. Protect the wire with non-metallic conduit.
4. Where meter is exposed to vehicle traffic, customer shall install protective barrier posts 36" from meter. Posts shall be 6" rigid galvanized steel pipe filled with concrete, capped, and painted bright yellow (see Exhibit 30).
5. Current transformer (CT) cabinet to be installed on exterior building wall. (For indoor CT cabinet installations, contact the regional Metering Services Section.)
6. Conduits shall enter CT cabinet from the side, bottom, or back. Conduit shall not enter the top of CT cabinet without obtaining Company approval.
7. See Exhibit 19 for CT cabinet mounting, installation, and information.

## Metering Installation Outdoor Current Transformer Cabinet Mounted on a Building

**FirstEnergy.**

Service Guide	REV.
EXHIBIT 20	1
	DATE
	7/21

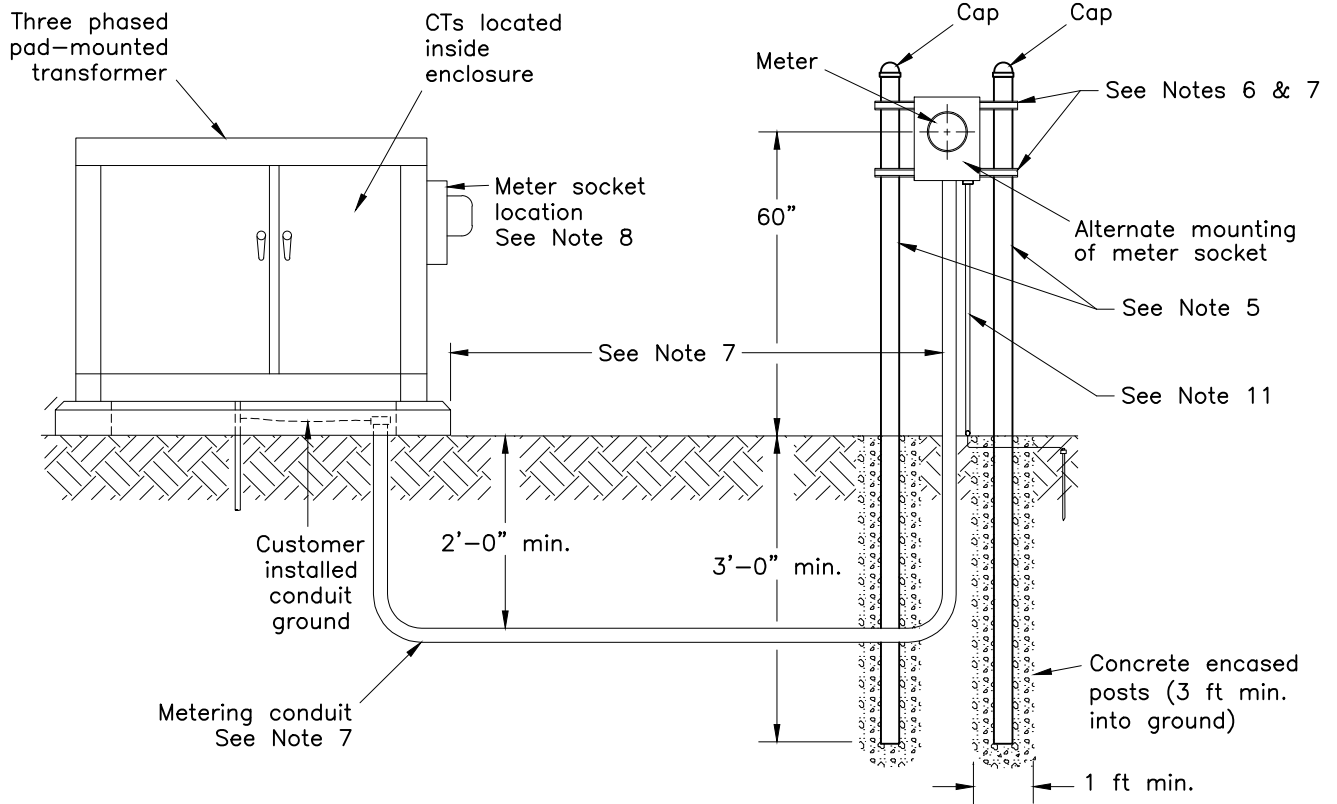

**The use of this Exhibit requires Company approval.**

**Notes:**

1. For customer/Company responsibilities, see Exhibit 1.
2. Customer shall consult the Company for the trench termination point and length of additional service cable to be provided for final connection by the Company.
3. The meter socket mounting may be on the transformer cabinet (installed by the Company). If this is not feasible, approval shall be obtained from the Company to use a stand-alone meter installation as described on this page.
4. All dimensions not defined are variable to accommodate metering apparatus.
5. Support post (customer-owned): use two 2-1/2 inch min. galvanized rigid metal conduits (RMC) -steel (min. 0.205" thick) capped and concrete encased in the ground.
6. Mounting hardware: use two 12-gauge 1-5/8" x 1-5/8" continuous slot hot dipped galvanized channels (e.g., Unistrut) complete with 1-1/4" x 5/16" dia. 13 thd. spring nut (2 per channel), 5/16" hex nut, and lock washer securely mounted to support posts.
7. Metering conduit: use 1-1/4" min. galvanized rigid metallic conduit with all threaded joints and insulated bonding bushings on both ends. Total length shall not exceed 50 feet. Conduit shall be grounded at the transformer.
8. When mounted on the transformer cabinet, the meter socket (installed by the Company) shall be located 6 inches from top of the cabinet and 6 inches from the front edge.
9. Where the meter is exposed to vehicle traffic, the customer shall install protective barrier posts 36 inches from the meter. Posts shall be 6-inch rigid galvanized steel pipe filled with concrete, capped, and painted bright yellow. Refer to Exhibit 30.
10. Customer to furnish and install 5/8-inch x 8-foot ground rod with a #6 AWG copper ground wire connected to the meter socket ground lug. Customer shall protect the wire with non-metallic conduit.

**Underground Secondary Service in  
3Ø Pad-Mounted Transformer with  
Current Transformers**

**FirstEnergy**

Service Guide	REV.
	1
<b>EXHIBIT 21</b>	DATE
	7/21

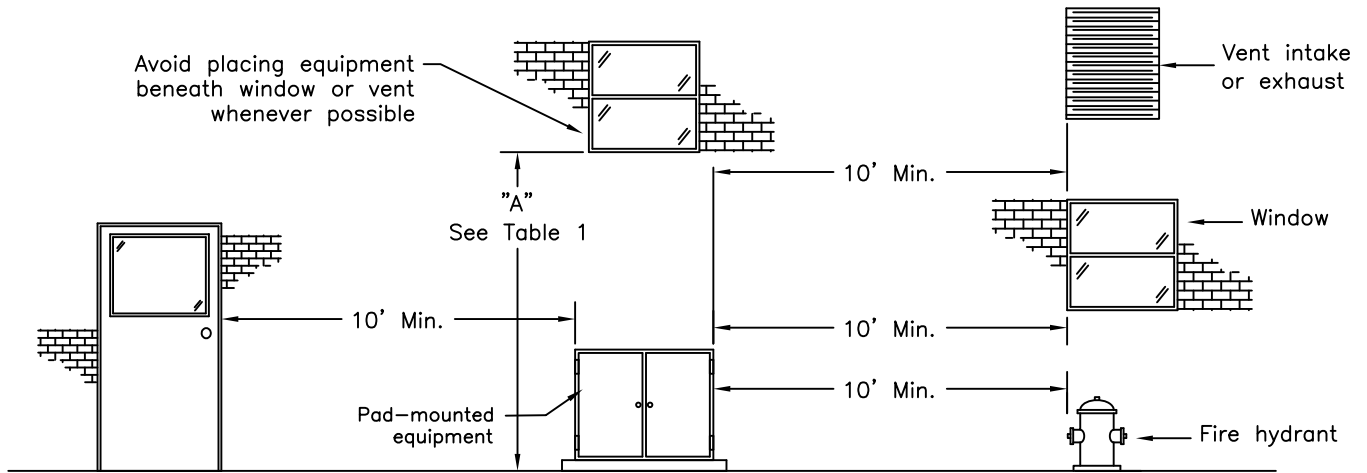

ELEVATION VIEW

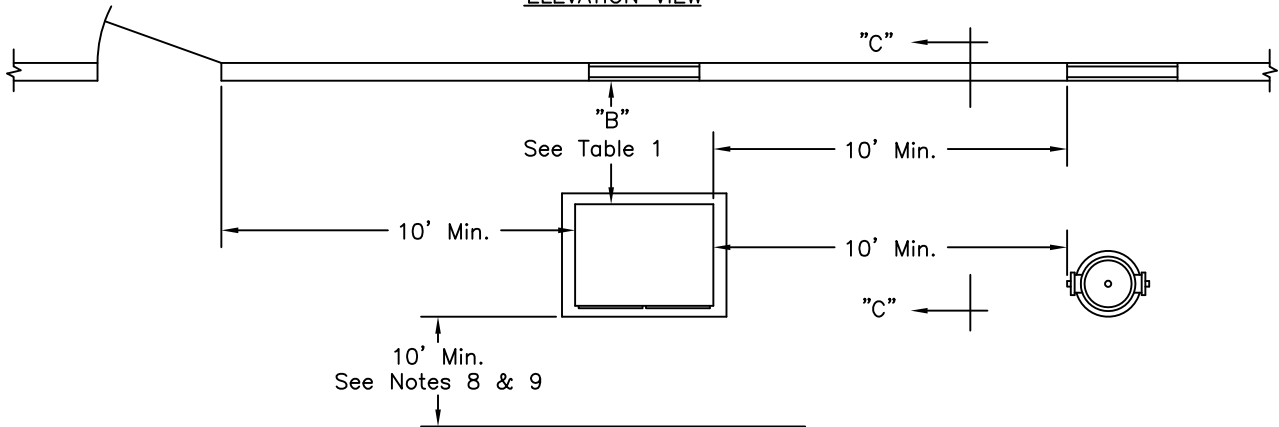

PLAN VIEW

Building Surface Type	Minimum Distance "B" in feet to building vertical surface	
	"A" > 18 ft	"A" ≤ 18 ft
Steel or masonry *	4 ft	10 ft
Wood, vinyl, or aluminum	10 ft	10 ft

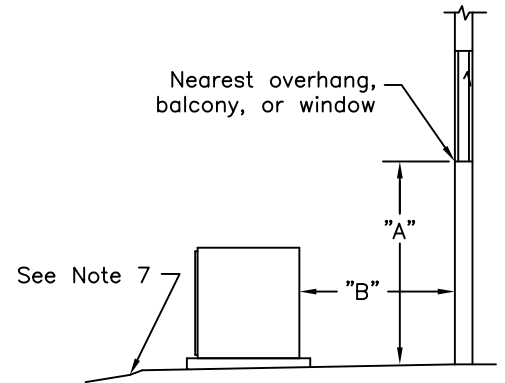

A = vertical distance in feet to nearest overhang, balcony, or window.  
 \* 2-hour fire rating (minimum)

**Notes:**

1. Customer is responsible to comply with any and all building codes, local ordinances, and insurance regulations associated with the equipment installation.
2. Adequate access shall be provided to accommodate line trucks or other necessary lifting equipment for maintenance or replacement.
3. Building overhangs, decks, steps, or balconies shall not extend over the top of pad-mounted equipment.
4. Minimum clearance of 3 ft to gas meter.
5. Minimum clearance of 10 ft to fire hydrants, fire escapes, sprinkler valves, standpipes, doorways, open stairways, or high pressure natural gas lines.
6. Minimum clearance of 15 ft to storage tanks containing flammable liquids or gases (e.g., propane, gasoline, or oxygen).
7. Area around pad-mounted equipment shall slope away from the building or be curbed to confine oil from a ruptured tank.
8. The front of the pad-mounted equipment shall face away from the building or other impediment. If equipment must face a building, 10 ft minimum clearance shall be maintained.
9. No vegetation at mature growth (e.g., shrubs), fences, or other permanent objects shall be set within 3 ft from the sides and back or 10 ft from the front or any side with an access door of any pad-mounted equipment (refer to Exhibit 23).
10. If Table 1 minimum clearances cannot be met, the customer shall construct a fire resistant barrier.

## Minimum Clearances from Structures for Oil-Filled Pad-Mounted Equipment

**FirstEnergy**

Service Guide	REV.
	1
EXHIBIT 22	DATE
	7/21

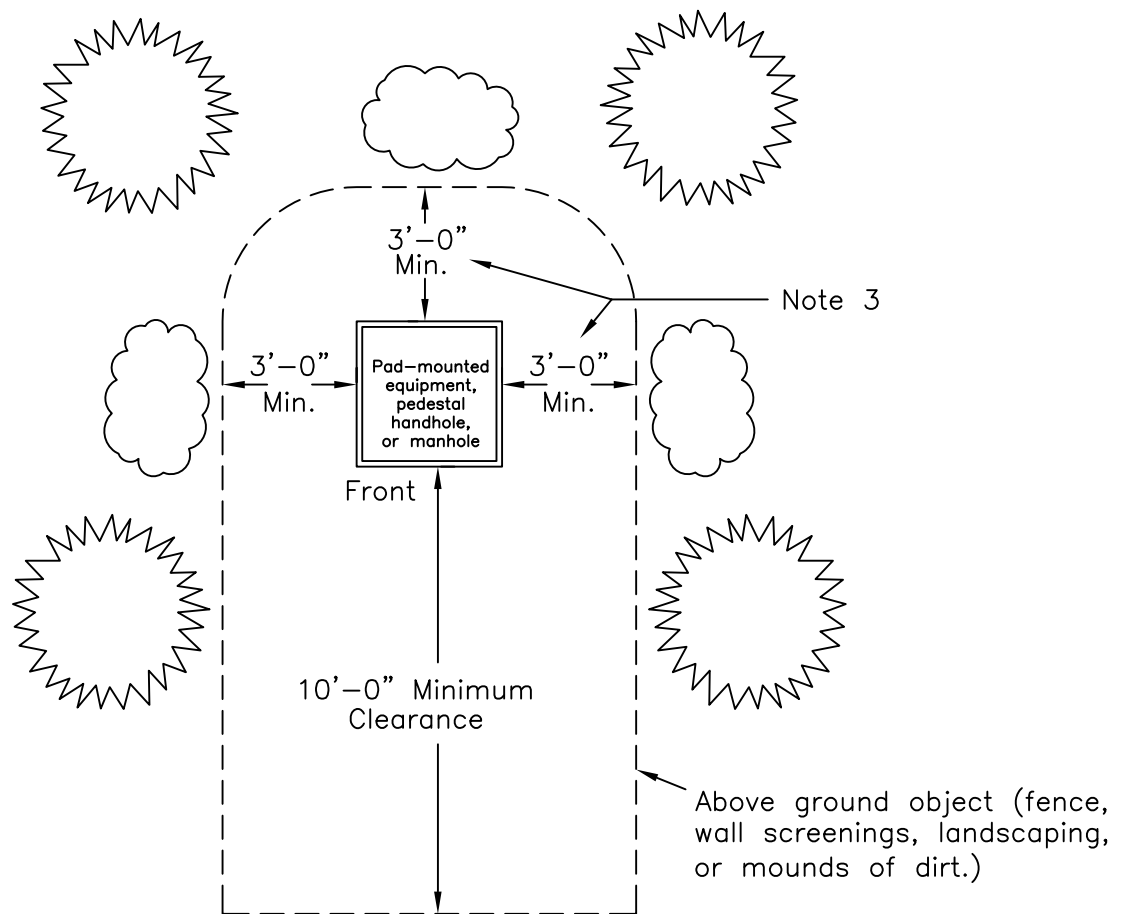

Notes:

1. **Warning:** Pad-mounted transformers and pad-mounted equipment have underground electric cables entering and exiting them below grade. When it is decided to install plants or objects around a pad, call the appropriate state One-Call agency found in Section 3.13 before digging so that underground cable locations can be marked.
2. Three (3) feet minimum clearance shall be maintained even after all plants have reached their maturity. **To allow future growth, plant vegetation should be placed at least seven (7) feet from the back and side of the pad-mounted device, pedestal, or hardware.** Avoid planting shrubs or setting posts directly over cables.
3. If pad-mounted equipment is a switch or other similar device with front, side, or rear doors, the minimum 3-foot clearance shall be increased to 10 feet.
4. Minimum safety clearances to gas meters shall be three (3) feet and to tanks containing flammable liquids or gases (e.g., propane, gas, oxygen) fifteen (15) feet.
5. For minimum clearances to buildings or structures – see Exhibit 22.
6. Company shall not be responsible for replacing shrubs, plants, fences, wall screenings, and other obstructions that need to be removed for maintenance or restoration work.

**Clearances of Pad-Mounted Equipment, Pedestals, Handholes, or Manholes from Shrubs, Plants, Fences, Wall Screenings, & Other Obstructions**

**FirstEnergy.**

Service Guide	REV.
	1
EXHIBIT 23	DATE
	7/21



Secondary/Service Conduit at Pole

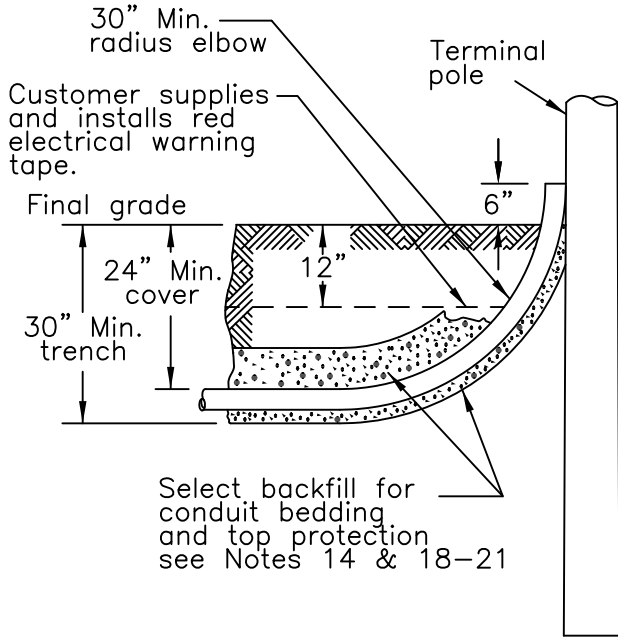

Secondary/Service Lateral Trench

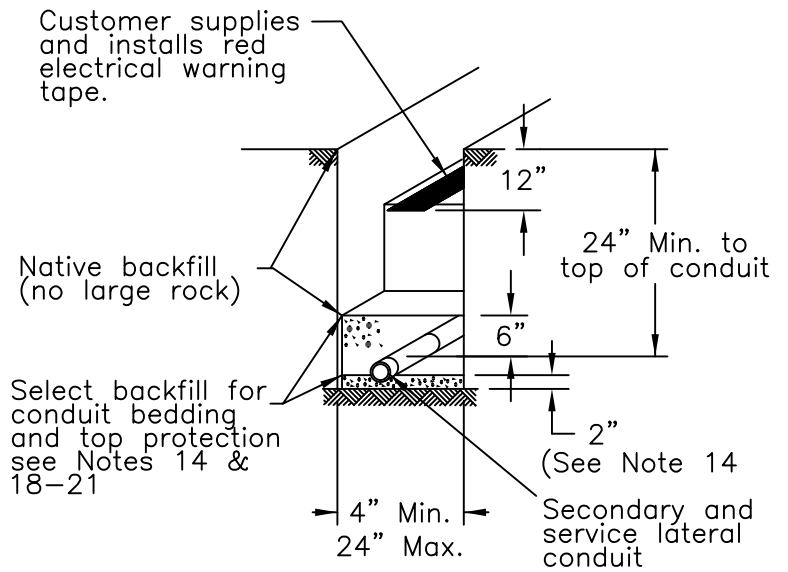

Primary Conduit at Pole

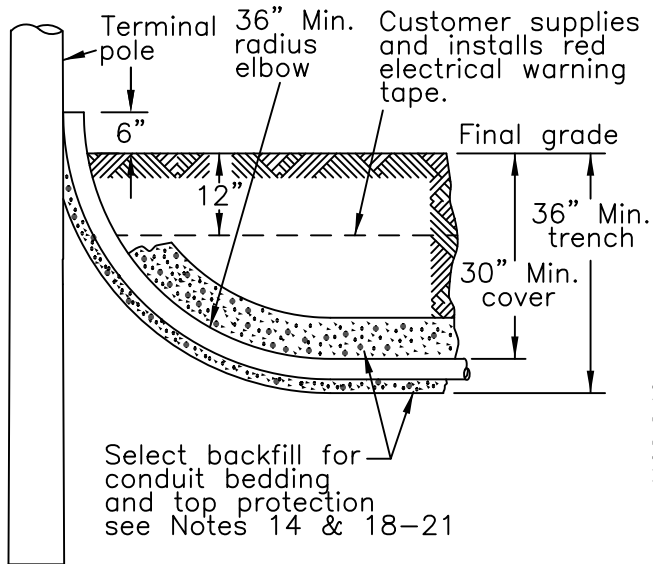

Primary Trench

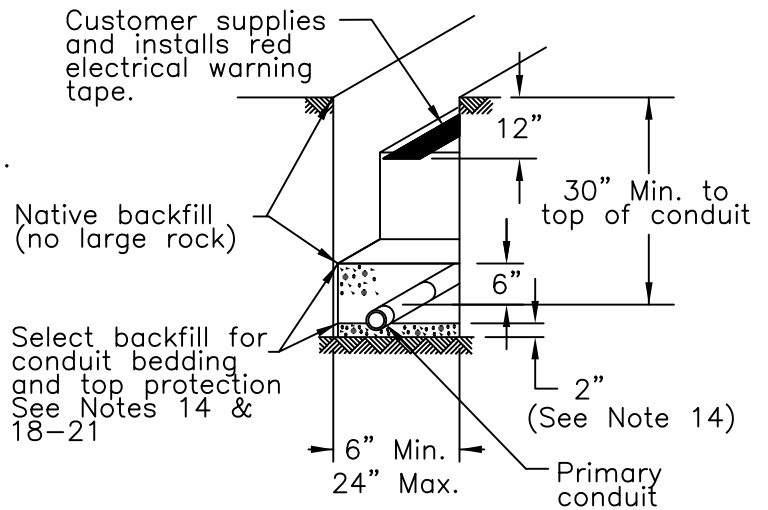

Notes:

1. For customer/Company responsibilities, see Exhibit 1.
2. Detailed notes for trench, conduit, and backfill requirements are provided in Exhibit 24, pages 2, 3, & 4.
3. See Notes 5 & 6, for joint-use trenches.

**Trenching, Conduit, & Backfill Requirements**

**FirstEnergy.**

Service Guide

REV.

1

**EXHIBIT 24**

DATE

7/21

Notes:

1. Customer shall provide trenching, conduit, and backfill to Company specifications.
2. Customer/contractor shall contact the Company for placement of both Company and customer electrical facilities and the approved trench route for connecting them.
3. The customer shall not deviate from the Company's approved trench route unless expressly approved in writing by the Company's engineering group representative. It shall be the customer's responsibility to notify the Company of any conflicts that the proposed electrical design creates with obstacles, other facilities, or easements. Changes requested following the design acceptance by the customer may require the Company to be compensated if facilities need to be relocated or project delays.
4. Before excavation begins, the excavator shall mark the proposed facilities (in white) and then notify the appropriate state One-Call agency to mark other underground facilities (refer to Sections 3.13 and 3.14).
5. The customer shall also coordinate the installation of all other buried utilities that are installing their facilities nearby, jointly occupying the trench (with Company approval), or crossing the electrical supply trench.
6. Below are the Company's required minimum clearances between electric supply lines and the following utility lines:
  - Steam or cryogenic lines - six (6) feet (use of an approved thermal barrier may reduce this clearance).
  - Fuel lines: four (4) feet for low-pressure natural gas, oil, propane, or other like fuels or ten (10) feet for gas lines that are high-pressure lines or are greater than four (4) inches in diameter.
  - Water, sewer, and telecommunication (i.e., telephone & CATV) lines - one (1) foot.
  - Clearances from telephone and CATV lines may be reduced to zero (0) feet or no deliberate separation (a.k.a. – random lay) if all involved parties agree and NESC [2017] Rule 354 is met.
  - Other utility companies (e.g., local steam, water, communication, sewer, and fuel companies) may require greater clearances than stated above.
  - If required clearances cannot be met (e.g., trenching through solid rock), clearances may be reduced to one (1) foot minimum if all involved parties agree.
  - Other facilities are prohibited from running above/below and parallel to the electrical cable without specific Company's approval.
7. The Company's minimum cover requirements for the primary (> 600 V) and secondary (< 600 V) conduits are based on providing adequate cover per NESC Code (depth). It shall be the responsibility of the customer to ensure that the minimum required coverages over the conduits are always maintained. Any necessary corrections to the depth of cover or required mechanical protection to prevent damage to the conduits from surface activity shall be the responsibility of the customer. Minimum cover over the conduits shall be maintained until all stages of the construction are completed.

**Minimum Cover Requirements**

VoltageV (Φ- Φ)	Minimum Cover Over Conduit(s)
< 600 V	24 inches
> 600 V to 50 kV	30 inches

8. When primary (> 600 V to 50 kV) and secondary (< 600 V) conduits share the same trench and are located side-by-side, the depth of cover for both conduits shall be to the primary conduit requirement with a minimum of two (2) inches of separation. If the conduits are stacked, the primary conduit(s) shall be on the bottom at the required primary depth. The secondary/service conduit(s) shall be on top of the primary conduit(s) with a minimum separation of two (2) inches between the conduits.
9. See Exhibit 24, page 1 for details on the trench dimensions (width and depth requirements). Customer shall contact the Company representative if the trench must be more than four (4) feet deep.

**Trench, Conduit, & Backfill Requirements**

***FirstEnergy***

Service Guide

Rev.

1

**EXHIBIT 24**

Date

7/21

Notes:

10. The customer shall clear the cable route of trees, tree stumps, boulders, or other obstructions at and below grade. The excavator shall grade the trench route to final grade level. The customer shall be responsible for any damage caused by the excavator. This includes damage to any tree whose root system is subsequently damaged from the trenching operations. The excavator shall grade all trench routes to final grade.
11. Customer/contractor shall not use power-excavating equipment within 18 inches of any existing buried cables or other electrical or communications facilities.
12. Excavated material (“spoils”) should be placed on the field side of the trench (unless directed by the Company otherwise), two (2) feet from the edge of excavations (per OSHA Standard 1926.651(j) (2)).
13. Standing water in the trench should be removed by pumping or draining (per OSHA Standard 1926.651(h)).
14. The bottom of the trench shall be relatively smooth, undisturbed earth, sand, or well-tamped earth which is free of rock, cinders, or sharp objects. Trench excavations in rocky soil may require a two-inch layer of select backfill on the bottom of the trench as determined by the Company.
15. Buried conduits shall be rigid PVC, heavy wall, sunlight resistant, listed and labeled, Schedule 40 conduit per NEMA TC2 (i.e., electrical grade). Additional requirements, such as concrete encasement of elbows or galvanized steel elbows, may be specified by the Company based on the specific design parameters of the conduit system and will be detailed in the electrical layout drawing. Customer shall contact the Company for the proper minimum conduit diameters.

**Conduit Requirements**

Conduit Size	Conduit Type	Conduit Bend Radius
6” – 8”	Sch40 PVC	48”
3” – 5”	Sch40 PVC	36”
1-1/2” or 2”	Sch40 PVC	18”

16. Customer-owned service lateral conduits (if used) shall be sized per NEC. Those conduits shall be supplied, installed, and maintained by the customer. Conduit for service laterals shall be a minimum of 3-inch diameter conduit.
17. Secondary/service conduit elbows shall have a minimum radius of 30 inches. Service riser conduit shall be rigid PVC, heavy wall, sunlight resistant, listed and labeled, Schedule 80 conduit per NEMA TC2. Primary conduit elbows shall have a minimum radius of 36 inches for sizes from 3” to 5”. For conduits 6 inch and larger, the elbows shall have a minimum radius of 48 inches.
18. All joints shall be glued together. Conduit shall be cleaned and confirmed with a mandrel 1/2 inch smaller than the conduit inside diameter. Unused conduits shall be plugged at each end to keep water and dirt out. When conduit runs are greater than twenty (20) feet, a ¼-inch unbroken nylon or polypropylene pulling rope shall be installed in each conduit. If the Company cannot pull conductors through the conduit run, or if the pulling rope is broken or unusable because it is glued to the conduit, the customer shall make the necessary repairs.
19. Before backfilling, the customer shall verify that the Company and local electrical inspector have completed all required inspections of the trench and conduit. In addition, the customer shall verify other utilities that were approved to use joint trench have completed their work.

Notes:

20. The customer shall backfill around all conduits with six (6) inches of select backfill. Select backfill shall be graded sand, stone dust, limestone dust, rock free earth or topsoil. Materials that “set up” such as fly ash, culm and foundry waste are not acceptable. The remainder of the trench shall be backfilled with native soil and not contain large rocks (greater than two (2) inch diameter), rocks with sharp edges or other debris. An additional six (6) inches of mounded backfill is recommended to allow for settling.
21. Backfill should be compacted in six-inch layers by hand or using a pneumatic or vibrating tamping equipment to lessen the effects of settling. Note: machine compaction should not be used within six inches of the conduit (per NESC Rule 353A). Do not run wheels or tracks of equipment along the trench to compact the backfill as this could damage the conduits.
22. The customer shall provide and bury a red “electrical” warning tape at least three (3) inches wide directly above all conduits twelve (12) inches below final grade as shown in Exhibit 24 (refer to NEC 300.5(D)(3)).
- 24 For cables located beneath roads under PennDOT jurisdiction, cables shall be installed in conduit, have a minimum of 36 inches of cover, and shall be completely backfilled with #2 RC aggregate.

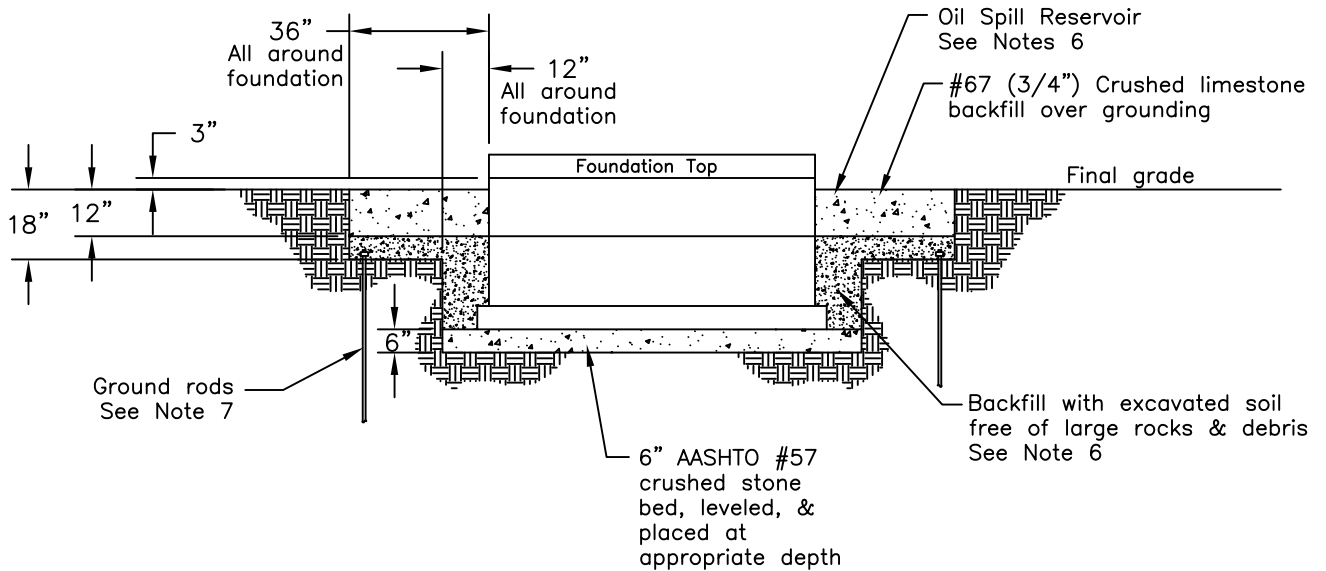
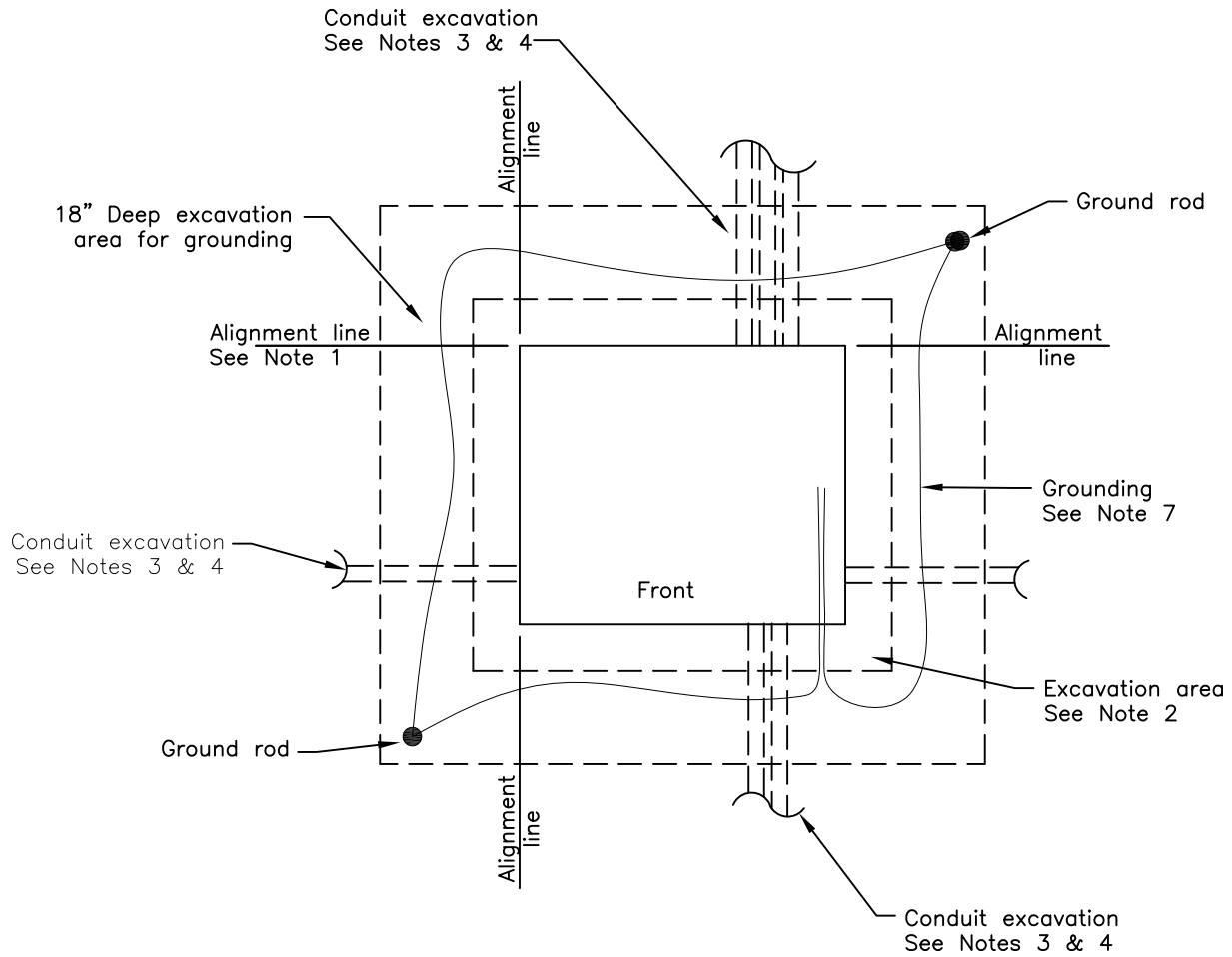

For dimensions see Exhibit 25 page 2 of 4.  
 For Notes see Exhibit 25 pages 3 & 4.

### Three-Phase Transformer Pre-Cast Concrete Foundation / Vault (Installation Details)

**FirstEnergy.**

Service Guide

REV.

1

EXHIBIT 25

DATE

7/21

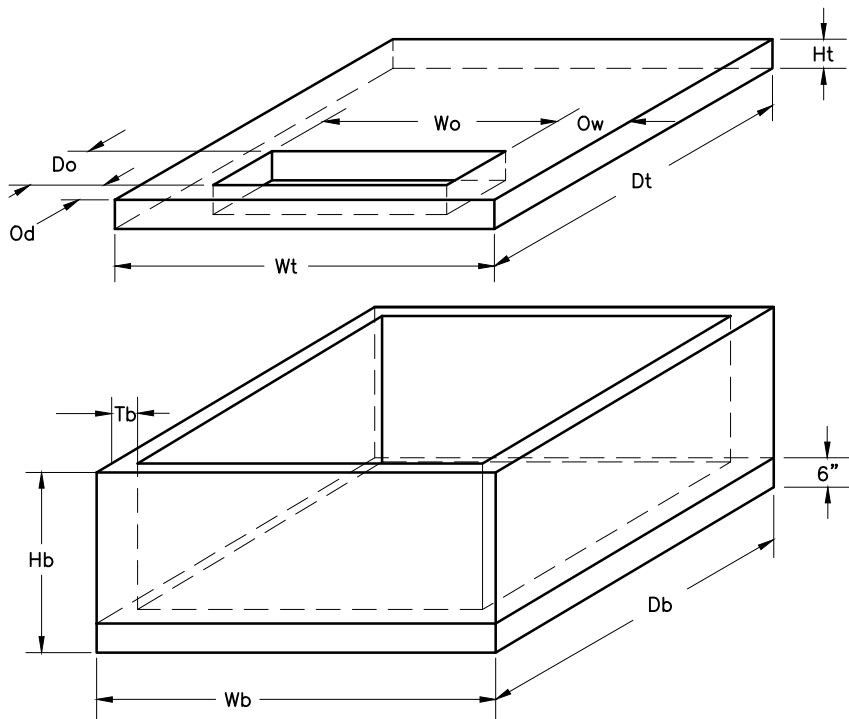

Pre-Cast Concrete Transformer Foundation Dimensions														
Transformer Size (kVA)	Found. Code	Base					Top				Opening in Top			
		Wb	Db	Hb	Tb	WT.	Wt	Dt	Ht	WT.	Wo	Do	Ow	Od
22,940 GrdY/14,400 Volt & Below														
45 - 150	J1	72"	54"	42"	4"	4,275#	72"	54"	6"	1,725#	55"	14"	8.5"	6"
225 - 1000	J2	78"	66"	42"	4"	8,000#	78"	66"	6"	2,400#	60"	19"	9"	6"
1500 - 2500	J3	96"	96"	42"	6"	12,000#	96"	96"	9"	6,400#	60"	19"	18"	9"
1500 - 2500 (Note 7)	J4	96"	96"	54"	6"	14,000#	96"	96"	9"	6,400#	60"	19"	18"	9"
34,500 GrdY/19,920 Volt														
1500 - 2500	J3	96"	96"	42"	6"	12,000#	96"	96"	9"	6,400#	60"	19"	18"	9"
1500 - 2500 (Note 7)	J4	96"	96"	54"	6"	14,000#	96"	96"	9"	6,400#	60"	19"	18"	9"
34,500 Delta Volt Live-Front (Includes CEI 36 kV System)														
All Sizes (Note 8)	J5	138"	120"	54"	6"	24,655#	138"	120"	9"	10,270#	102"	36"	18"	18"

Pre-Cast Concrete Transformer Foundation - Excavation Dimensions					
Transformer Size (kVA)	Found. Code	Width	Depth	Height	Stone Base
22,940 GrdY/14,400 Volt & Below					
45 - 150	J1	96"	78"	45"	6"
225 - 1000	J2	102"	90"	45"	6"
1500 - 2500	J3	120"	120"	45"	6"
1500 - 2500 (Note 7)	J4	120"	120"	57"	6"
34,500 GrdY/19,920 Volt					
1500 - 2500	J3	120"	120"	45"	6"
1500 - 2500 (Note 7)	J4	120"	120"	57"	6"
34,500 Delta Volt Live-Front (Includes CEI 36 kV System)					
All Sizes (Note 8)	J5	162"	144"	57"	6"

**Three-Phase Transformer  
Pre-Cast Concrete Foundation / Vault  
(Fabrication Details)**



Service Guide	REV.
	1
EXHIBIT 25	DATE
	7/21

General Notes:

1. The customer shall contact the Company prior to beginning work to discuss the details of the transformer foundation such as position, orientation, working clearances, barrier protection, construction specifications, and inspection procedures. The customer is responsible for purchasing, owning, installing, and maintaining the pre-cast transformer foundation and associated secondary rack equipment (if needed). The contractor/developer shall coordinate site preparations with the desired delivery date. The customer shall provide a clear and firm (e.g., concrete, asphalt, or grasscrete) approach to within ten (10) feet of the point of delivery and keep the area clear of obstructions that may block the use of delivery vehicles or Company vehicles (e.g., crane access to the transformer).
2. The customer/contractor is responsible for the excavation to install the transformer foundation and for backfilling afterward. The excavation shall be two (2) feet wider than the vault dimensions (shown Exhibit 25, page 2). The excavation depth shall be 45- inches deep for 42-inch high foundations bases or 57-inches deep for 54-inch high foundation bases. Six (6) inches of AASHTO #57 crushed stone shall be leveled and compacted in the bottom of the excavation as a base. Pavement (concrete, asphalt, or grass-crete) shall be provided to within ten (10) feet of the installation for Company trucks. The customer should provide three (3) pieces of 4" X 4" X 8' lumber off to the side for temporarily unloading the foundation top at delivery time.
3. Conduits shall enter near the corners of the foundation (refer to Exhibit 25, page 1) through knockouts to provide for proper cable bending radius and pulling set-up and to facilitate cable racking (when needed). Conduits shall have end bells and shall be terminated flush with the inside surface of the foundation. The customer/contractor shall re-mortar the knockout area around the conduit penetration into transformer foundation to prevent water migration.
4. The customer/contractor will furnish and install all service cables as required per Exhibit 1. The customer/contractor shall allow sufficient slack, approximately five (5) feet, in the service lateral cables after they are racked. The slack allows the service cables to be trained so that the weight of the cables is supported by the cable racks and not supported by the transformer bushings. When requested, the customer/contractor shall supply and install cable racks (e.g., 30-inch rack made by A. B. Chance (Hubbell), using the inserts, on the side(s) of the foundation to support the service cables a minimum of 12 inches above floor level (per NEC Article 300.32). Refer to ANSI C135.35 for galvanized cable rack and hooks, and ASTM A153 for zinc coating (hot dip) on iron and steel hardware.
5. The customer shall seal around the service cables inside the conduits (with approved foam) to prevent migration of water or gases. All unused ducts shall also be capped.
6. Backfill on all sides up to finish grade with 6" minimum of AASHTO #57 crushed stone to form a reservoir to contain the transformer oil in case of a leak.
7. The developer shall install a continuous loop of #2 bare, seven (7) strand, soft drawn copper ground wire connected to two (2) 5/8" X 8' ground rods installed in opposite corners of the vault excavation in undisturbed earth (refer to Exhibit 25, page 1). Both ends of the ground wire shall enter the foundation through a one (1) inch diameter hole to be drilled or chiseled in the upper right-hand corner of the knockout panel. Each ground wire tail shall extend fifteen (15) feet inside the vault beyond the knockout point.
8. The decision to open the sump drainage or leave it closed will be made by the Company based on field conditions. The developer is responsible for taking corrective action (improve drainage, sump pump, etc.) for a foundation that fills with water and water is leaking through service conduits into the customer's building. The area surrounding the foundation shall be graded so that ground water will not collect.

**Three-Phase Transformer  
Pre-Cast Concrete Foundation / Vault  
(General Notes)**

**FirstEnergy**

Service Guide	Rev. 1
<b>EXHIBIT 25</b>	Date 7/21

General Notes:

9. The customer shall install protective barriers when the transformer is located in an area exposed to vehicular traffic (refer to Exhibit 30), consult the Company for details.
10. The deeper base for the 1500-2000 kVA transformer is used when secondary conduit configuration requires a deeper wall to maintain NEC/NESC minimum cover over the conduit.
11. Foundation for 34.5 kV live-front transformer includes a six-inch thick dividing wall between the high voltage and the low voltage compartments centered 55-1/2" from the inside edge of the low voltage compartment side wall.

**Three-Phase Transformer  
Pre-Cast Concrete Foundation / Vault  
(General Notes)**

***FirstEnergy***

Service Guide

Rev.

0

Date

7/21

**EXHIBIT 25**



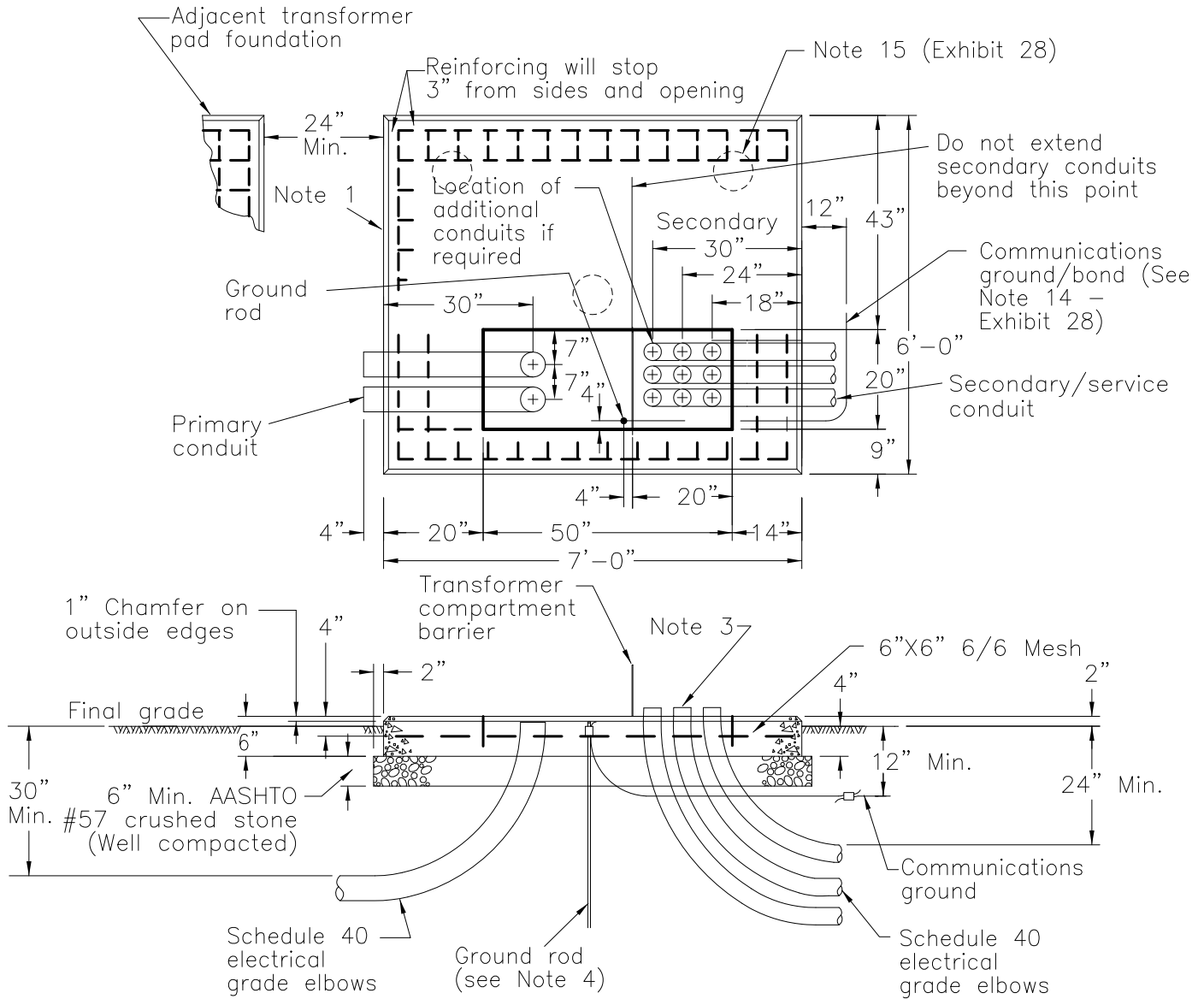

**Notes:**

1. For customer/Company responsibilities, see Exhibit 1.
2. Reference Exhibit 28 for concrete pad foundation, pad-mounted transformer General Notes.
3. Secondary conduits should not extend more than 2 inches above the top of foundation. Primary conduits should be cut off 2 inches below the top of foundation to allow for terminating the cables.
4. Customer shall furnish and install one 5/8-inch diameter x 8-foot ground rod, grounding connections, and #6 copper communications ground wire (minimum wire required - 7 1/2 feet).
5. See Exhibit 22 for clearance from building wall or other parts of building.

**Concrete Flat-Pad Foundation  
Pad-Mounted Transformer 75 to 500 kVA  
Three-Phase, 34.5 kV & Below High-Side**

**FirstEnergy.**

Service Guide	REV.
<b>EXHIBIT 26</b>	1
	DATE
	7/21

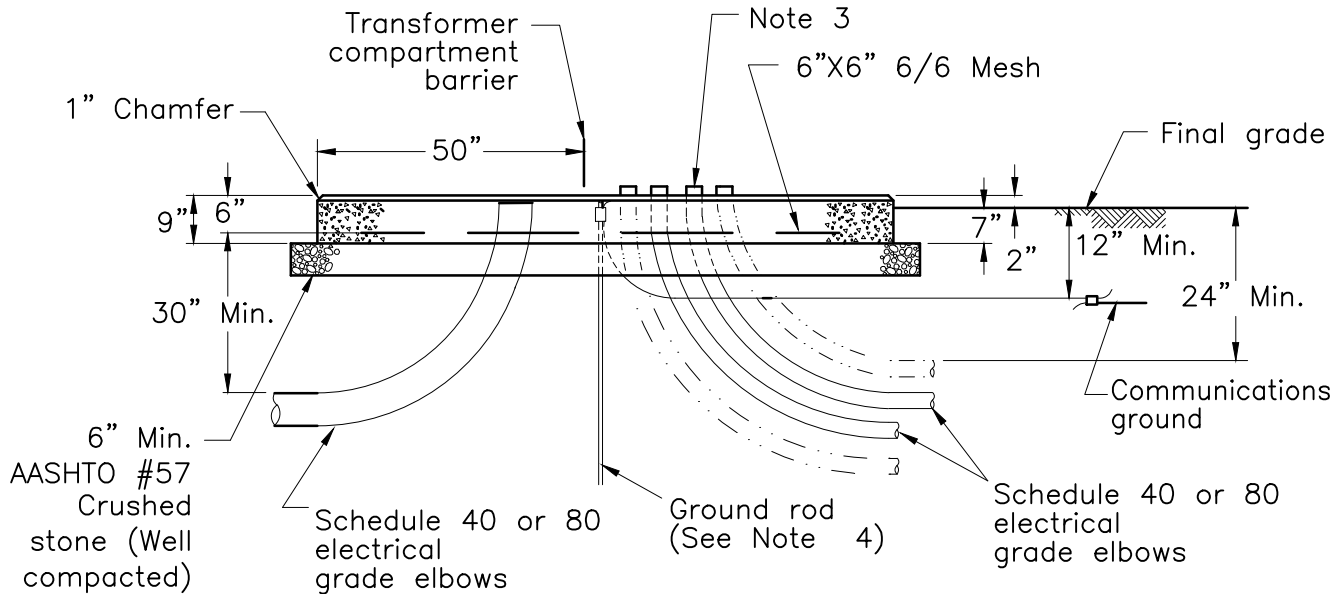
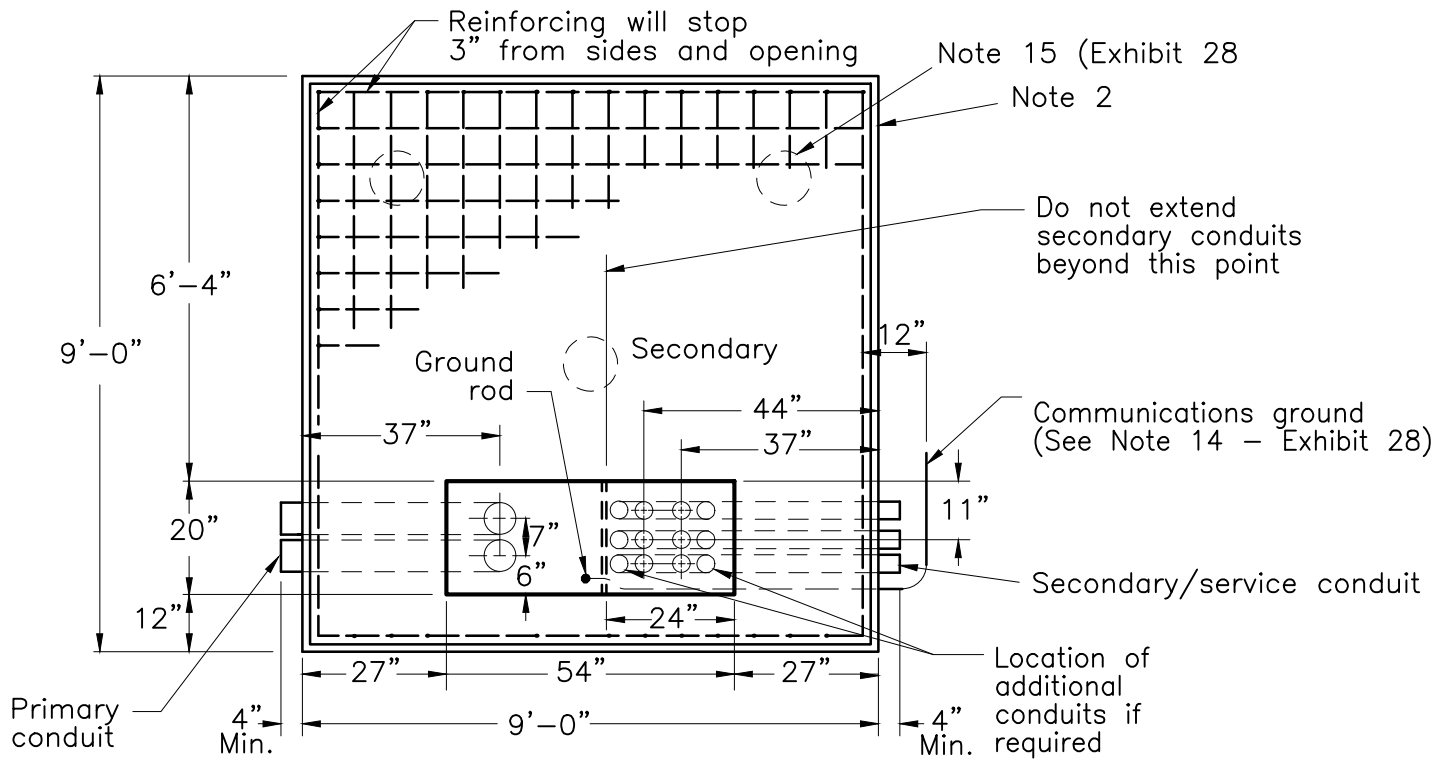

**Notes:**

1. For customer/Company responsibilities, see Exhibit 1.
2. Reference Exhibit 28 for concrete pad foundation, pad-mounted transformer General Notes.
3. Secondary conduits should not extend more than 2 inches above the top of foundation. Primary conduits should be cut off 2 inches below the top of foundation to allow for terminating the cables.
4. Customer shall furnish and install one 5/8-inch diameter x 8-foot ground rod, grounding connections and #6 copper communications ground wire (minimum wire required - 7-1/2 feet).
5. See Exhibit 22 for clearance from building wall or other parts of building.

**Concrete Flat-Pad Foundation  
Pad-Mounted Transformer 750 to 2500 kVA,  
Three-Phase, 34.5 kV & Below High-Side**

<b>FirstEnergy</b>	
Service Guide	REV. 1
<b>EXHIBIT 27</b>	DATE 7/21

Notes:

1. The developer shall contact the Company prior to beginning work to discuss the details of the transformer foundation position and orientation, working clearances, barrier protection, constructions specifications, and inspection procedures. The customer is responsible for installing, owning, and maintaining the transformer foundation. The developer shall provide a clear and firm approach to the transformer foundation and keep the area above the foundation clear of obstructions that may block the use of Company vehicles (e.g., crane access to the transformer).
2. Install conduits before placing the pad. Conduits shall not be placed under sections of the pad supporting the transformer so that the original ground will not be disturbed.
3. Conduit shall be rigid, electrical grade, Schedule 40, or Schedule 80 PVC. See Exhibit 24 for details.
4. Backfill shall be clean soil, free of large stones (greater than two (2) inch diameter) and any perishable materials. All backfill shall be spread and compacted in maximum layers of six (6) inches.
5. Level and thoroughly compact the six (6) inch AASHTO #57 crushed stone base.
6. Concrete pad may be poured-in-place or may be pre-cast (4000 min. psi concrete).
7. To prevent water migration from concrete when pouring, place waterproof membrane on crush stone base before pouring concrete.
8. Reinforcing wire mesh shall conform to ASTM designation A185.
9. Cement to be 1 or 1-A and meet ASTM designations C-150 and C-175, respectively.
10. Poured pad concrete to develop minimum 4000 psi at 28 days age, contain 5.5 bags of cement per cubic yard and a maximum of six (6) gallons of water per 94-pound bags of cement and conform to ASTM designation C-94. Fourteen (14) day minimum drying time before transformer is set. For Exhibit 26, the volume of concrete is approximately 0.7 cubic yards or for Exhibit 27, the volume of concrete is approximately 1.7 cubic yards.
11. Customer shall seal all openings around conduits with grout; cap all spare conduits to prevent entry of rodents and animals into transformer compartment.
12. If conduit extends into a building, they shall be sealed with approved foam (per NEC) at building end to prevent gas from entering building through the conduit.
13. Where damage to transformer by vehicles is possible, transformer shall be protected by appropriate barriers. (See Exhibit 30 for details). Consult with the Company for details.
14. Grounding/bonding of all communications equipment (telephone, CATV, etc.) that are within six (6) feet of the pad is required. Connection for communications ground shall be minimum #6 solid copper wire that is attached directly to the ground rod and extends twelve (12) inches beyond the edge of the concrete pad foundation (minimum wire required: Exhibit 26 - 7.5 feet or Exhibit 27 – 8.5 feet).
15. In areas where settling may occur, install three (3) concrete piers eight (8) inch minimum diameter, 36 inches deep, in a triangular configuration under the foundation. (See Exhibits 26 and 27.) Developer shall contact Company for details.

**Concrete Flat-pad Foundation  
Pad-Mounted Transformer  
General Notes**

**FirstEnergy**

Service Guide	Rev. 1
<b>EXHIBIT 28</b>	Date 7/21

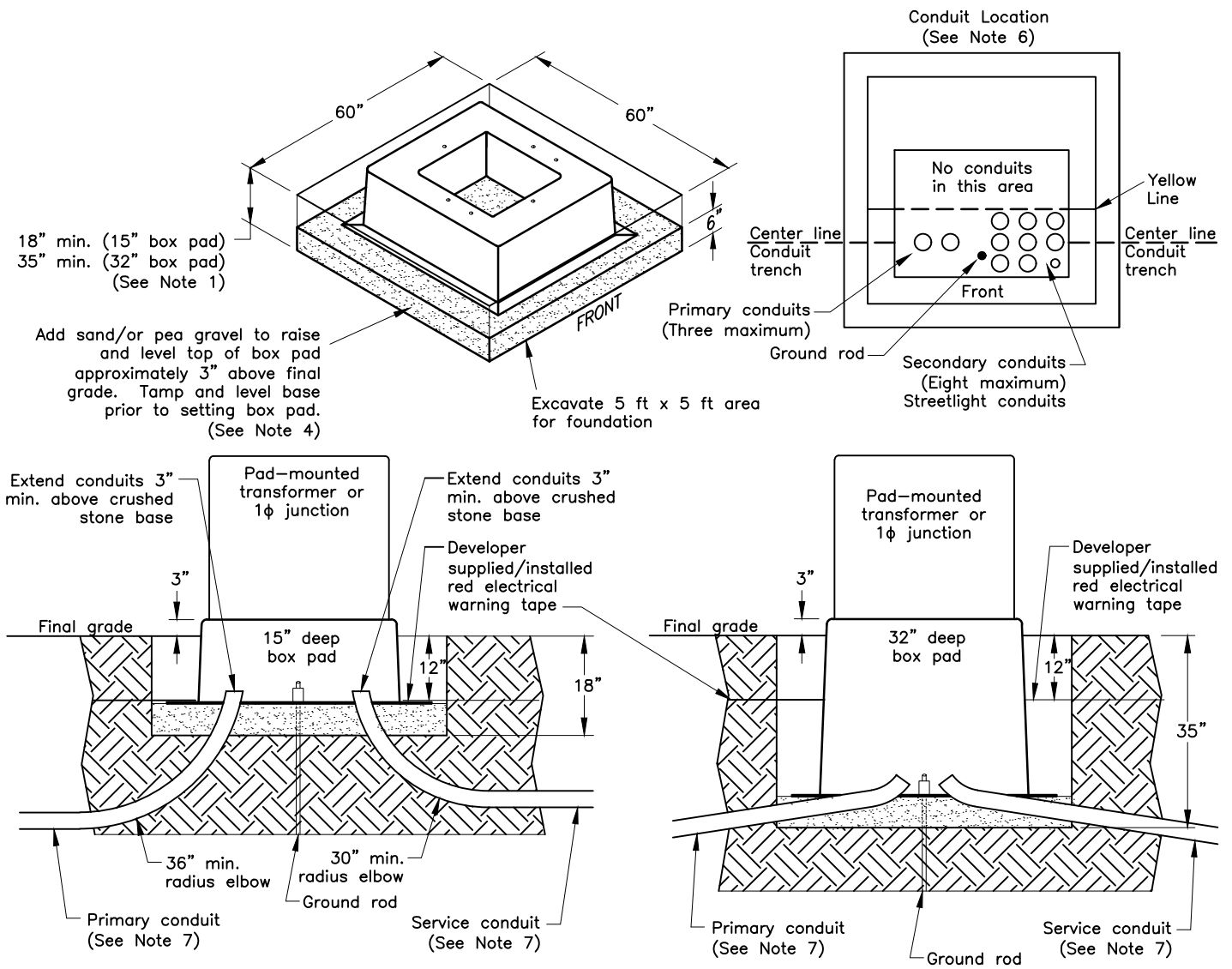

**Notes:**

1. Customer shall contact the Company before excavating to determine the location and orientation of the box pad. Company shall specify and supply a 15" or a 32" deep fiberglass box pad foundation.
2. Use the "FRONT" label on the top of the foundation for orientation.
3. Customer shall notify the state One-Call agency 3 days before construction. Refer to Sections 3.13 & 3.14.
4. Install box pad foundation on six (6) inches of leveled and tamped sand or pea gravel. Backfill after foundation is installed with native soil containing no large rocks (greater than two inches), sharp rocks, or other debris.
5. For Company-owned services 350 kcmil or less, use 3" PVC electrical-grade conduit. For customer-owned services follow NEC requirements.
6. Primary conduits shall be placed in front of the yellow line on the box pad on the left side of the opening. Secondary and streetlight conduits shall be placed in front of the yellow line on the right side of the opening.
7. Cut off the conduit elbows three (3) inches above the compacted base. Install 1/4-inch unbroken nylon or polypropylene pulling rope in each conduit.
8. Customer shall furnish and install one 5/8" X 8' ground rod driven at least 7'6" into the ground in the front-center of the box pad opening as shown.

**Typical Single-Phase Box Pad  
Foundation Installation  
(1φ Transformer or 1φ Junction)**



Service Guide	REV. 1
EXHIBIT 29	DATE 7/21

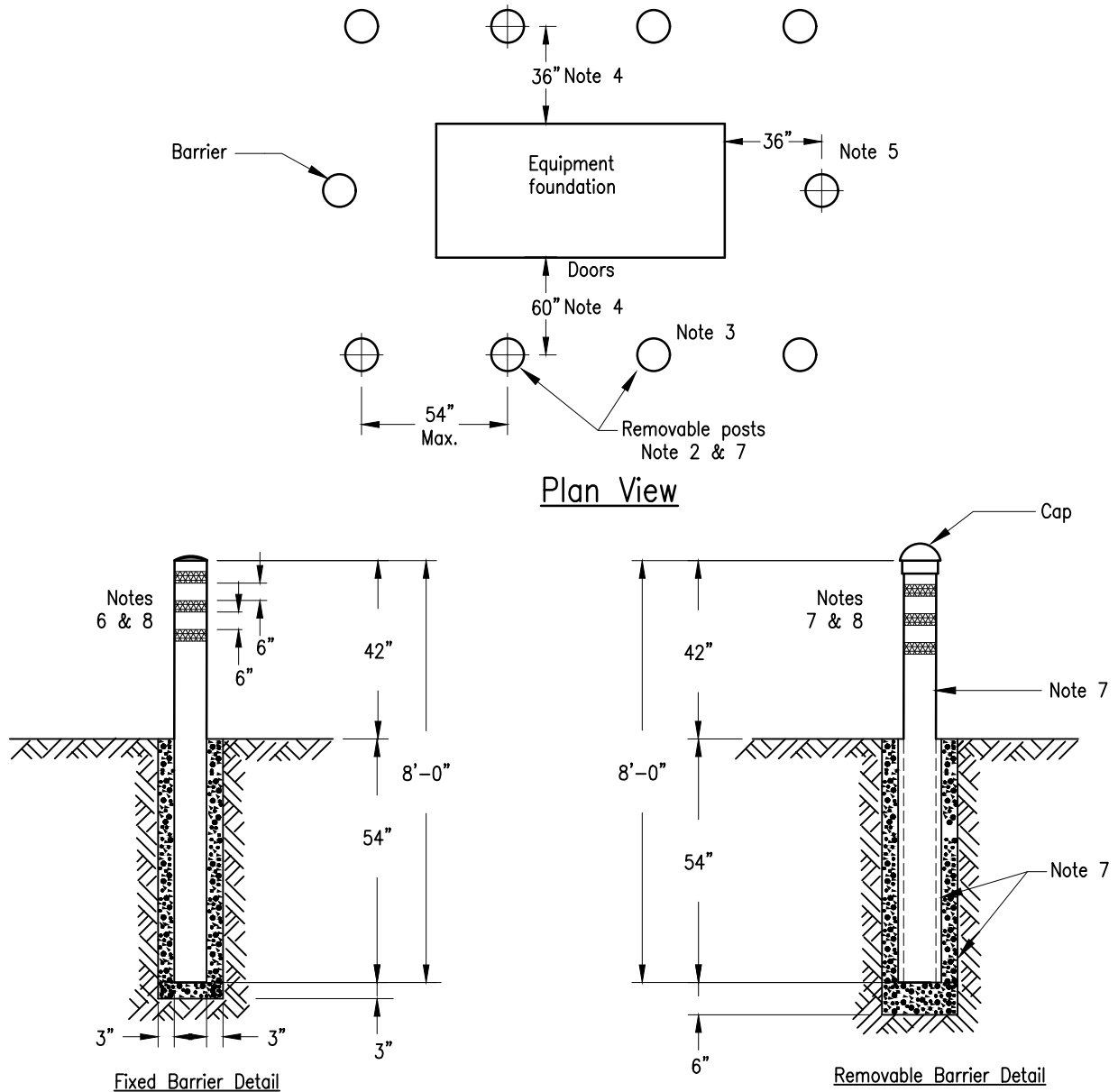

**Notes:**

1. Use barriers to protect equipment or poles from possible damage from vehicles. Customer shall contact Company for placement.
2. Provide clearance for the operation, removal, or replacement of equipment when overhead obstacles prevent removal of equipment, one barrier shall be removable.
3. When necessary, height of barrier above ground may be increased to prevent large vehicles from striking pad-mounted equipment.
4. Position barriers 60" from equipment foundation on all sides where equipment doors will be located. Removable barriers shall not be installed as a means of providing clearance to open equipment doors.
5. With the Company approval this distance may be reduced to 24 inches provided clearances are maintained for items such as transformer radiators and metering.
6. For fixed vehicle barrier, use 6-inch diameter rigid galvanized steel conduit, cut to 8 feet and fill with concrete. Encase in 3 inches of concrete, as shown. Power installed bumper posts (minimum size: 84 inches long, 3-1/2-inch diameter, 8-inch helix) are also approved.
7. For removable vehicle barriers, use 6-inch diameter PVC Schedule 40 conduit, cut to 54 inches and encased in concrete. Insert 8 feet of 5-inch diameter galvanized steel conduit (do not fill with concrete), with cap, into PVC conduit. Use 6 inches of compacted stone or gravel for sump.
8. Vehicle barriers shall be painted yellow with three strips of 3-inch wide white reflective tape.
9. Customer shall notify state One-Call agency before excavation for posts.

**Vehicular Barrier for  
Pad-Mounted Equipment & Poles**

**FirstEnergy.**

Service Guide	REV.
	1
EXHIBIT 30	DATE
	7/21

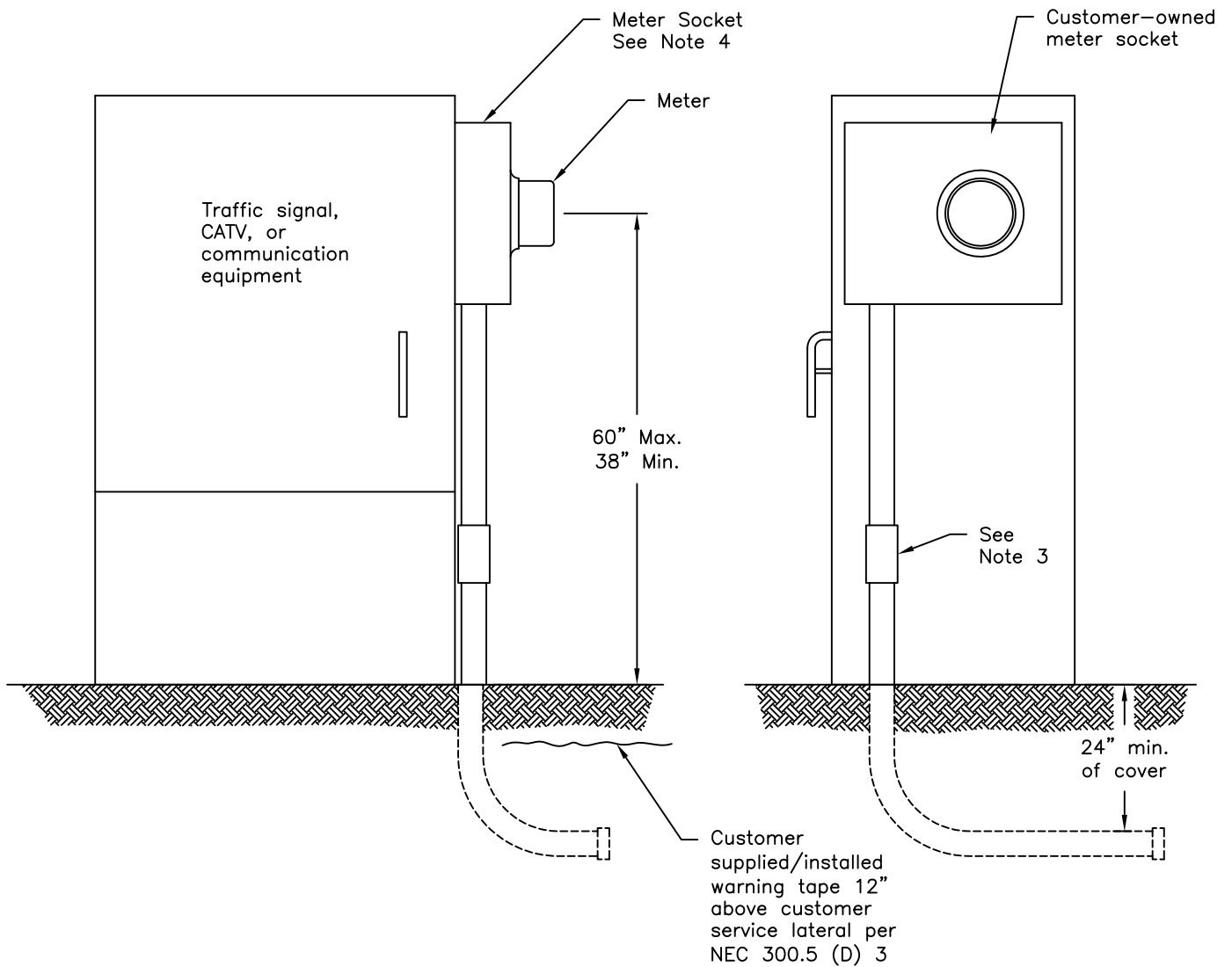

Notes:

1. For customer/Company responsibilities, see Exhibit 1.
2. Supply-side conduit shall be rigid galvanized or IMC steel, or Schedule 80 PVC (electrical grade).
3. The customer shall provide ground movement protection per NEC 300.5 (J) to prevent damage due to settling.
4. Meter socket shall be surface mounted. Do not build-in or enclose the meter socket or meter within the structure.

**Typical Underground Service  
Traffic Signal, CATV, or Communication  
Stand-Alone Equipment**

**FirstEnergy.**

Service Guide	REV.
	0
<b>EXHIBIT 31</b>	DATE
	7/21



Ohio Edison • The Illuminating Company • Toledo Edison  
 Met-Ed • Penelec • Penn Power • Jersey Central Power & Light  
 West Penn Power • Mon Power • Potomac Edison

**BUILDER INSTALL REQUEST**

Please Type or Print

Check the Appropriate Boxes Below

FORM 1046 (REV. 03-14)

**OPERATING COMPANY**

<input type="checkbox"/> <b>OHIO EDISON</b> PHONE 1-800-633-4766 FAX 1-877-289-3674	<input type="checkbox"/> <b>THE ILLUMINATING CO.</b> PHONE 1-800-589-3101 FAX 1-877-289-3674	<input type="checkbox"/> <b>TOLEDO EDISON</b> PHONE 1-800-447-3333 FAX 1-877-289-3674	<input type="checkbox"/> <b>PENN POWER</b> PHONE 1-800-720-3600 FAX 1-877-289-3674	<input type="checkbox"/> <b>POTOMAC EDISON</b> PHONE 1-800-686-0011 FAX 1-877-289-3674
<input type="checkbox"/> <b>MET-ED</b> PHONE 1-800-545-7741 FAX 1-877-289-3674	<input type="checkbox"/> <b>PENELEC</b> PHONE 1-800-545-7741 FAX 1-877-289-3674	<input type="checkbox"/> <b>JCP&amp;L</b> PHONE 1-800-662-3115 FAX 1-877-289-3674	<input type="checkbox"/> <b>MON POWER</b> PHONE 1-800-686-0022 FAX 1-877-289-3674	<input type="checkbox"/> <b>WEST PENN POWER</b> PHONE 1-800-686-0021 FAX 1-877-289-3674

**DETAILS OF SERVICE REQUIREMENTS**

TEMPORARY ONLY (Fee Will Be Assessed)  PERMANENT  TEMP TO PERM (Fee May Be Assessed)

**BUILDER INFORMATION**

REQUESTED BY	BUILDING COMPANY NAME	COMPANY PHONE NO.
CONTACT PERSON	CONTACT PHONE NO.	FAX NO.

\* If service application is in the "builder's "name, the "buyer" must contact us when it is time to transfer service.

**BILLING NAME AND MAILING INFORMATION**

NAME OF PARTY RESPONSIBLE FOR THE ELECTRIC BILL	SOCIAL SECURITY NO./TAX ID	CONTACT PHONE NO.	
E-MAIL ADDRESS			
STREET ADDRESS (MAILING)	CITY	STATE	ZIP CODE

**LOCATION WHERE SERVICE IS NEEDED**

NAME OF DEVELOPMENT OR ALLOTMENT	LOT NO.		
BUILDING NO.	FLOOR NO.	ROOM/APARTMENT/UNIT NO.	
STREET ADDRESS	CITY	STATE	ZIP CODE
COUNTY/TOWNSHIP/BOROUGH/TAX DISTRICT	NEAREST CROSS STREET/POLE NO.		

**CONNECTION TYPE**

<input type="checkbox"/> UNDERGROUND <input type="checkbox"/> OVERHEAD	SQ. FT. OF STRUCTURE	SET BACK FROM ROAD (In Feet)
---	----------------------	------------------------------

**PREMISE TYPE**

Is this application for a multi-tenant structure?  YES  NO If yes, how many units? \_\_\_\_\_  
 Please attach a separate page with the list of street addresses and lot numbers.

RESIDENTIAL  
 HOUSE  MOBILE HOME  APARTMENT  DUPLEX  TOWNHOUSE  OTHER \_\_\_\_\_

NON-RESIDENTIAL  
 COMMERCIAL  INDUSTRIAL  CABLE COMPANY EQUIPMENT TYPE OF STRUCTURE/SITE USE \_\_\_\_\_

**SERVICE ENTRANCE**

AMPERAGE <input type="checkbox"/> 100 <input type="checkbox"/> 200 <input type="checkbox"/> OTHER _____	VOLTAGE <input type="checkbox"/> 120/240 <input type="checkbox"/> 120/208 <input type="checkbox"/> 277/480 <input type="checkbox"/> OTHER _____	PHASE <input type="checkbox"/> SINGLE PHASE <input type="checkbox"/> THREE PHASE
--	--	---

**DETAILS REGARDING STRUCTURE**

<b>HEATING SYSTEM</b>	<b>HEAT SOURCE</b>	<b>HEAT TYPE</b>
	<input type="checkbox"/> ELECTRIC <input type="checkbox"/> PROPANE <input type="checkbox"/> OIL <input type="checkbox"/> KEROSENE <input type="checkbox"/> GAS <input type="checkbox"/> UNKNOWN <input type="checkbox"/> OTHER (DESCRIBE) _____	<input type="checkbox"/> GEOTHERMAL HEAT PUMP <input type="checkbox"/> HOT WATER/STEAM <input type="checkbox"/> BASEBOARD <input type="checkbox"/> ADD-ON HEAT PUMP <input type="checkbox"/> HOT AIR/ELECTRIC FURNACE <input type="checkbox"/> UNKNOWN <input type="checkbox"/> OTHER (DESCRIBE) _____

<b>WATER HEATER</b>	<b>HOT WATER SOURCE</b>	<b>HOT WATER TYPE</b>
	<input type="checkbox"/> ELECTRIC <input type="checkbox"/> GAS <input type="checkbox"/> OIL <input type="checkbox"/> PROPANE	<input type="checkbox"/> STORAGE TANK <input type="checkbox"/> OTHER _____ <input type="checkbox"/> TANK LESS <input type="checkbox"/> SIZE IN GALLONS _____

AIR CONDITIONER <input type="checkbox"/> YES <input type="checkbox"/> NO TONS _____	COOLING TYPE <input type="checkbox"/> CENTRAL AIR <input type="checkbox"/> HEAT PUMP <input type="checkbox"/> WINDOW/WALL	WELL PUMP <input type="checkbox"/> YES <input type="checkbox"/> NO <input type="checkbox"/> UNKNOWN
--	--	--

OTHER HIGH USAGE APPLIANCES/EQUIPMENT:

NAME OF ELECTRICIAN:	PHONE NO.:
----------------------	------------

STAGE OF CONSTRUCTION  STAKED  FOUNDATION  FRAMED  UNDER ROOF  OTHER \_\_\_\_\_

DIRECTIONS/COMMENTS