



# PTFE Rotary Seals

## Water Engine Cooling Pump

The raw water engine cooling pump is the heart of the marine engine, supplying a continuous flow of raw water to maintain temperatures consistent with the demanding engine performance.

Typical applications for this pump include: Chrysler Marine M80 (CW) and M383X, M413E, M440X engines, Crusader Model 220, 270, 300 and 350 engines, Marine Power engines, Osco Motors engines, Pleasure craft engines, Volvo Penta engines as well as others.

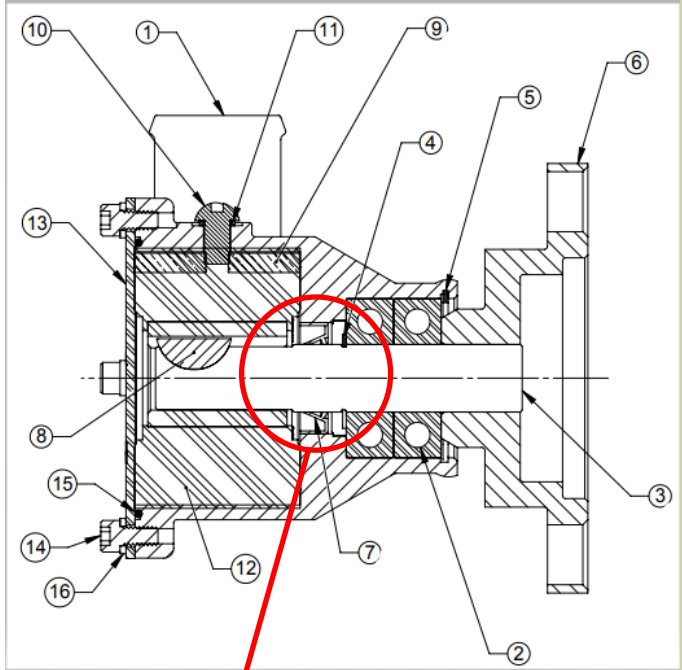

At GS Engineering Group we aim to solve challenging sealing applications and design products for industries such as:

- Automotive
- Aerospace
- Industrial
- Oil and Gas
- Medical
- Food and Beverage
- Motorsports
- Sustainable Energies

