

CORE PRODUCTS CATALOG 2018



© Quanics, Inc. 2018

Toll Free - 877-782-6427
Phone - 502-992-8200
Fax - 502-812-1081

PO BOX 1520
6244 Old Lagrange Rd, STE 5
Crestwood, KY 40014

orders@quanics.net
www.quanics.net
www.quanicsstore.com

Quanics, Inc.

April 2018

Dear Friends,

My heart has always been with the onsite installer/contractors and septic service companies that are the backbone of our industry. We will always try to treat you the way we want to be treated and make buying and using Quanics' products as easy as possible.

We have made this Core Products Catalog easy to use by focusing on the essential products. In areas where wholesale distribution of our products is not available, we invite contractors to buy direct or from our website. Everywhere we have wholesale distribution we encourage contractors to buy through their local wholesaler/pre-caster.

Following the sale of the Zabel®¹ and after a ten year break, I returned to run Quanics in August of 2016. I am glad to be back, enjoying the challenge, and we are on the move.

We made several key changes over the past 21 months:

- Our AeroCell™ and BioCoir™ packed bed media filters are now NSF certified in INFILTRATOR® Water Technologies'² polypropylene tanks reducing the cost of our advanced treatment systems by 30%.
- Our standard ATS-8, ATS-6 can be purchased with built in recirculation dividers eliminating the need for an external recirculation device which saves material and installation labor costs.
- Our website www.Quanics.net has been completely rebuilt and we have added two onsite stores www.QuanicsStore.com and www.SepticMall.com.
- Our product line has been organized into
 - Quanics Core Products™ (a full line of components for septic and advanced onsite treatment systems), and
 - Quanics Packaged Systems™ (AeroCell™ and BioCoir™ secondary and tertiary treatment systems, sand filter kits, and packaged STEP Systems).
- We have also made internal changes, reorganizing our warehouse and assembly facility, and improving product quality and processing.

Please take a look at our new lower prices and let us know how we might serve you.

We appreciate your business.

Best Regards,

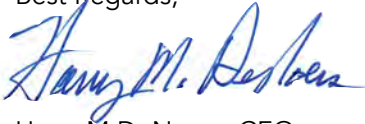

Harry M DeNoers, CEO

Quanics, Inc.

¹ Zabel® is a registered trademark owned by Polylok™, Wallingford, CT 06492

²INFILTRATOR® is a registered trademark of Infiltrator® Water Technologies, Old Saybrook, CT 06475

**QUANICS CORE
PRODUCTS CATALOG
2018**

INDEX

Alarms, Controls, Switches & Accessories	1-6
Distribution Valves	7-9
Filtered Pump Vaults	9
Grommets	10
Orifice Shields	10
Flow Divider/Director	10
Effluent Discharge	11-12
Lids, Risers, Adapters, Basins	13-14

ALARMS, CONTROLS, SWITCHES & ACCESSORIES

Alarms



Tank Alert® AB Indoor Alarm

The Tank Alert® AB (auto-reset, battery backup) indoor alarm system provides audible/visual warning of threatening liquid level conditions in lift pump chambers, sump pump basins, holding tanks, sewage, agricultural and other waste applications. The horn can be silenced, but the alarm light remains on until the condition is remedied.

Part Number	Model	Description
AC-1011421	TA AB-01H	120V with 15' SJE SignalMaster® High Level



Tank Alert® EZ Indoor/Outdoor Alarm

The indoor/outdoor Tank Alert® EZ alarm is easy to install and features an innovative, sleek 2-color molded enclosure which integrates the LED red translucent beacon. The alarm sounds and the upper housing half illuminates when a potentially threatening liquid level condition occurs. The audible alarm can be silenced by pressing the Test/Silence button, but the alarm light will remain on until the condition is remedied.

Part Number	Model	Description
AC-1036592	TAEZ-01HTB	120V, Terminal Block with 15' SJE SignalMaster® High Level

Motor Contactor Control



MODEL 112 SINGLE PHASE SIMPLEX

The Model 112 control panel provides a reliable means of controlling one 120, 208, or 240 VAC single phase pump in pump chambers, sump pump basins, irrigation systems and lift stations. Two control switches activate a magnetic motor contactor to turn the pump on and off. If an alarm condition occurs, an additional alarm switch activates the audible/visual alarm system.

Part Number	Model	Description
AC-1019840.	1121W114H17A	120/208/240V, Circuit Breaker, (3) SJE SignalMaster® Switches

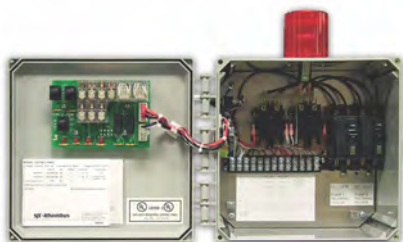

MODEL 122 SINGLE PHASE DUPLEX

The Model 122 control panel is designed to alternately control two 120, 208, or 240 VAC single phase pumps in pump chambers, sump pump basins, irrigation systems and lift stations. The alternating action equalizes pump wear; and this system provides override control should either pump fail. If an alarm condition occurs, an alarm switch activates the audio/visual alarm system.

Part Number	Model	Description
AC-1019842	1221W114H6A1	120/208/240V, Circuit Breakers, Aux. Contacts, (3) SJE SignalMaster® Switches



JB Pluggger

The JB Pluggger system is a NEMA 4X junction box providing a convenient location to connect all wiring required for a typical pumping station installation. It employs a receptacle to accept a 120 VAC or 230 VAC piggy-back plug and a pump plug. It includes a terminal strip to connect an alarm system in the junction box. Package ensures a liquid-tight seal and strain relief for the cable entering the junction box from the pumping station.

Part Number

AC-1007936

Description

JB Pluggger, 120V, Cord Seal, Conduit Hubs, Riser Extension, No Alarm or Floats



Ultra Nator™

The Ultra Nator™ control and alarm system controls two alternating single phase 120V pumps in duplex pump applications. Plug and play design features fail, high water, horn disable, pump run and power on. Touch pad buttons for alarm test, horn silence, manual pump run, test/reset and battery test function. 9V battery backup for alarm system. (Battery Not Included)

Part Number

AC-1029624

Description

120V, (2) 10 foot SJE MicroMaster® Switches



PS Patrol®

The PS Patrol® system features a sleek, angled removable clear cover for easy access for field wiring and viewing components. Red LEDs illuminate top of cover in alarm condition for easy 360° visual indication. It features a receptacle for easy connection of pump and piggy-back pump switch. Large incoming power terminal block for easy wiring. Includes cord seal for sealing the switch and pump cables; auxiliary contacts for attaching remote devices. Controller accepts 5" square post or 4" pipe for mounting. Available with or without 32" mounting post.

Part Number Model

AC-1022728 PSP120V6H17A

Description

120V, No Pump Switch, SJE SignalMaster® Switch

EZ Series®



EZ Series® Simplex

The EZ Series® Simplex control panel is designed to control one 120, 208, 240 VAC single phase pump in water and sewage installations. The control panel features a display on the inside of the front cover for programming and system monitoring including pump elapsed time (hh:mm) and events - time or demand dose.

Part Number	Model	Description
AC-1030111	EZS21W114H3A6 A8AC10E15A17G	120/208/240V, Locking Latch, Pump & Control/Alarm Circuit Breakers, ETM, Cycle Counter, Aux. Alarm Contacts, (3) SJE MilliAmpMaster™ Switches



EZ Series® Plugger

The EZ Series® Plugger control panel is easy to install and provides convenient wiring connection for use with one single phase pump in effluent and sewage installations. The panel includes a built-in high water alarm with test/normal/silence switch and incorporates a receptacle to accept 120 VAC or 240 VAC pump and piggy-back pump plugs to be easily routed and sealed into the panel. The post can be mounted in the ground directly, over a 4x4, or over conduit.

Part Number	Model	Description
AC-1032932	EZP11W6C0H10E P17A	120V, Locking Latch, Mounting Post, Alarm Switch, No Pump Switch, SJE Signal Master® Switch

Installer Friendly Series®

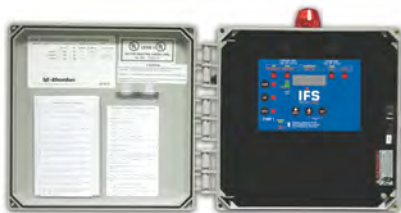

IFS® Single Phase Simplex (Demand/TD)

The IFS simplex control panel is designed to control one 120, 208, 240 VAC single phase pump in water and sewage installations. The panel features an easy-to-use touch pad with display on the inner door for programming and system monitoring. Touch pad features: Level Status Indicators, HOA (Hand-Off-Automatic) Buttons, Pump Run Indicator, LED Display - time or demand dose. Pump ETM and cycle counter.

Part Number	Model	Description
AC-1022726	IFS21W114H8AC 17G	120/208/240V, Demand Dose, Display Board, Pump Circuit Breaker, (3) SJE MilliAmpMaster® Switches



IFS® Single Phase Duplex (Demand/TD)

The IFS duplex control panel is designed to control two (alternating) 120, 208, 240 VAC single phase pumps in water and sewage installations. The alternating action equalizes pump wear and this system provides override control should either pump fail. The panel features an easy-to-use touch pad with display on the inner door for programming and system monitoring. Touch pad features: Level Status Indicators, HOA (Hand-Off-Automatic) Buttons, Pump Run Indicators, Lead/Lag Selector, LED Display. The panel dose or demand dose. Pump ETMS and cycle counters.

Part Number	Model	Description
AC-1022727	IFS41W114H8AC 17G	120/208/240V, Demand Dose, Display Board, Pump Circuit Breakers, (3) SJE MilliAmpMaster® Switches

Control Switches



SJE SignalMaster® - Mechanical

The SJE SignalMaster® for pump control panels and alarms in water or sewage applications. The SJE SignalMaster® control switch is not sensitive to rotation. This normally open control switch turns on (closes) when the switch tips slightly above horizontal signaling a high level, and turns off (opens) when the switch drops slightly below horizontal. It has a control differential of 1.5 inches (4 cm) above or below horizontal level.

Part Number	Model	Description
AC-1006044.	20SGMPCNO	20', Pipe Clamp, Normally Open



Sensor Float® - Mercury

The Sensor Float® for control panels and alarms in sewage and non-potable water applications. The Sensor Float® control switch is not sensitive to rotation and is suitable for use with intrinsically safe circuits. This normally open control switch turns on (closes) when the switch tips slightly above horizontal signaling a high level, and turns off (opens) when the switch drops slightly below horizontal. It has a control differential of .5 inches (1 cm) above or below horizontal.

Part Number	Model	Description
AC-1002117	15PCNO	15', Pipe Clamp, Normally Open

Mechanical Pump Switches



SJE PumpMaster®

The SJE PumpMaster® mechanically-activated, wide-angle pump switch is designed for direct control of pumps up to 1/2 HP at 120 VAC and 1 HP at 230 VAC in water and sewage applications. This pump switch is not sensitive to rotation or turbulence allowing it to be used in both calm and turbulent applications. It features heavy-duty contacts and adjustable pumping range of 7 to 36 inches (18 to 91 cm). Available with or without piggy-back plug.

Part Number	Model	Description
AC-1002715	15PMDP1WP	15', Pump Down, 120V with plug
AC-1002725	15PMUWOP	15', Pump Up, 120/230V without plug



SJE PumpMaster® Plus

The SJE PumpMaster® Plus mechanically-activated, wide-angle switch is designed for direct control of pumps up to 3/4 HP at 120 VAC and 2 HP at 230 VAC in water, sewage applications. This pump switch is not sensitive to rotation or turbulence allowing it to be used in both calm and turbulent applications. It also features heavy-duty contacts and adjustable pumping range of 7 to 36 inches (18 to 91 cm).

Part Number	Model	Description
AC-1003243	15PMPD1WP	15', Pump Down, 120V with plug

Mechanical Pump Switches



Double Float® Master

The Double Float® Master mechanically-activated, wide-angle pump switch is designed to control pumps up to 1 HP at 120 VAC and 2 HP at 230 VAC in non-potable water and sewage not sensitive to rotation or turbulence. This switch is voltage sensitive - use with correct voltage relay eliminates pump chatter in turbulent conditions allowing the pump switch to operate relay control panels for larger pump applications. It features an adjustable pump range of 3 to 48 inches (7.6 to 122 cm) with increased pumping range up to 6 feet (1.8 meters) available.

Part Number	Model	Description
AC-1016864	15DFMMD1WP	15', Pump Down 120V, with plug



SJE VerticalMaster®

The SJE VerticalMaster® mechanically-activated pump switch is designed for direct control of pumps up to 1/2 HP at 120 VAC and 1 HP at 230 VAC in non-potable water and sewage. The SJE VerticalMaster® pump switch is not sensitive to turbulence. It features heavy-duty contacts and adjustable pumping range of .75 to 6.5 inches (2 to 17 cm).

Part Number	Model	Description
AC-1003590	10VM1WP	10', 120V with plug

Mercury Pump Switches



Junior Super Single®

The Junior Super Single® mercury-activated, wide-angle pump switch is designed for direct control of pumps up to 1/2 HP at 120 VAC and 1 HP at 230 VAC in non-potable water and sewage applications. Although this switch is not sensitive to rotation, it is affected by turbulence and should be mounted in a non-turbulent location. It features an adjustable pumping range of 6.5 to 19 inches (16.5 to 48 cm).

Part Number	Model	Description
AC-1001817	15JSD1WP	15', Pump Down, 120V with plug



Double Float®

The Double Float® mercury-activated, wide-angle pump switch is designed to control pumps up to 15 FLA, 90 LRA, 120 VAC or 240 VAC in non-potable water and sewage applications. This switch is voltage sensitive - use with correct voltage. The holding relay eliminates pump chatter in turbulent conditions allowing the pump switch to operate relay control panels for larger pump applications. It features an adjustable pumping range of 1.75 to 48 inches (4.45 to 122 cm) with increased pumping range up to 6 feet (1.8 meters) available.

Part Number	Model	Description
AC-1002022	15DFD1WP	15', Pump Down, 120V with Plug

Accessories



Cord Seal

The Cord Seal provides strain relief and a liquid-tight seal. Seals 1-3 cables in a 2" terminal adapters and 1-6 cables in a 2 1/2" terminal adapters. PVC plugs are included (for unused cable positions). Ground wire included.

Part Number	Description
-------------	-------------

AC-1008517	2 inch Cord Seal (1-3 Cables)
------------	-------------------------------

AC-1037126	2.5 inch Cord Seal (1-6 Cables)
------------	---------------------------------



Hub Assembly

The Hub Assembly provides liquid-tight conduit attachment location. Available in 1, 1.5, 2 and 2.5 inch sizes. UL Listed and CSA Certified terminal adapter.

Part Number	Description
-------------	-------------

AC-1009305	1 inch Hub Assembly
------------	---------------------

AC-1008848	1.5 inch Hub Assembly
------------	-----------------------

AC-1008849	2 inch Hub Assembly
------------	---------------------

AC-1037128	2.5 inch Hub Assembly
------------	-----------------------



Float Bracket

The four Float Bracket supports 1-4 floats and can be directly mounted to a wall or used with wall mounting device. It provides convenient location to stow excess float cord. Supplied with UL recognized cord straps relief connectors.

Part Number	Description
-------------	-------------

AC-1009432	4 Float Bracket with Mounting Device
------------	--------------------------------------



Cable Weight

The Cable Weight provides an accurate pivot point for suspended float switches. Gripper teeth on clip and weight channel securely lock float cable into place and can be adjusted without the use of tools.

Part Number	Description
-------------	-------------

AC-1002230	Cable Weight
------------	--------------

DISTRIBUTION VALVES

SERIES 4000 LIGHT-DUTY/LOW-PRESSURE

Part#/Description

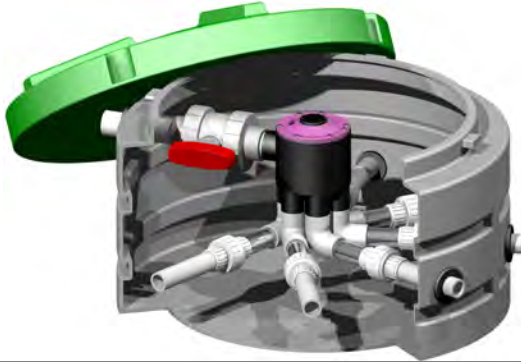

PDS-DV-4606-AP

Pre-Assembled 4000 Series K-Rain Valve W/6 Outlets + 6 Cams for distribution to SIX ZONES

Heavy Duty 26" by 12" diameter rotational molded basin, 26" lid, gasket pack, and security screws. Inline quick disconnect shut-off and quick disconnect on outgoing lines; and K-RAIN 4600 Indexing valve. Operates at Low 10 GPM (38 LPM) at Pressures of 25-75 PSI (1,7-5,2 bar). Two Year Limited Warranty.



PDS-DV-4605-AP

Pre-Assembled 4000 Series K-Rain Valve W/6 Outlets + 5 Cams for distribution to FIVE ZONES

Heavy Duty 26" by 12" diameter rotational molded basin, 26" lid, gasket pack, and security screws. Inline quick disconnect shut-off and quick disconnect on outgoing lines; and K-RAIN 4600 Indexing valve. Operates at Low 10 GPM (38 LPM) at Pressures of 25-75 PSI (1,7-5,2 bar). Two Year Limited Warranty.



PDS-DV-4404-AP

Pre-Assembled 4000 Series K-Rain Valve W/4 Outlets + 4 Cams for distribution to FOUR ZONES

Heavy Duty 26" by 12" diameter rotational molded basin, 26" lid, gasket pack, and security screws. Inline quick disconnect shut-off and quick disconnect on outgoing lines; and K-RAIN 4400 Indexing valve. Operates at Low 10 GPM (38 LPM) at Pressures of 25-75 PSI (1,7-5,2 bar). Two Year Limited Warranty.



PDS-DV-4403-AP

Pre-Assembled 4000 Series K-Rain Valve W/4 Outlets + 3 Cams for distribution to THREE ZONES

Heavy Duty 26" by 12" diameter rotational molded basin, 26" lid, gasket pack, and security screws. Inline quick disconnect shut-off and quick disconnect on outgoing lines; and K-RAIN 4400 Indexing valve. Operates at Low 10 GPM (38 LPM) at Pressures of 25-75 PSI (1,7-5,2 bar). Two Year Limited Warranty.

DISTRIBUTION VALVES

SERIES 4000 LIGHT-DUTY/LOW-PRESSURE

Part#/Description

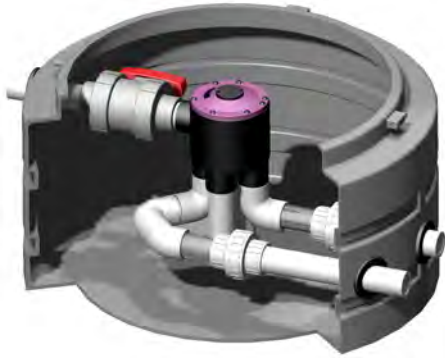

PDS-DV-4402-AP

Pre-Assembled 4000 Series K-Rain Valve W/4 Outlets + 2 Cams for distribution to TWO ZONES

Heavy Duty 26" by 12" diameter rotational molded basin, 26" lid, gasket pack, and security screws. Inline quick disconnect shut-off and quick disconnect on outgoing lines; and K-RAIN 4400 Indexing valve. Operates at Low 10 GPM (38 LPM) at Pressures of 25-75 PSI (1,7-5,2 bar). Two Year Limited Warranty.

SERIES 6000 HEAVY DUTY/HIGH PRESSURE

Part#/Description



PDS-DV-6606-AP

Pre-Assembled 6000 Series K-Rain Valve W/6 Outlets + 6 Cams for distribution to SIX ZONES

Heavy Duty 26" by 18" diameter rotational molded basin, 26" lid, gasket pack, and security screws. Inline quick disconnect shut-off and quick disconnect on outgoing lines; and K-RAIN 6600 Indexing valve. Metal Die-Cast Body – Durable, long lasting and capable of high pressure applications. Operates at 15 GPM (57 LPM) at Pressures of 25–150 PSI (1,7-10,3 bar). Two Year Limited Warranty.



PDS-DV-6605-AP

Pre-Assembled 6000 Series K-Rain Valve W/6 Outlets + 5 Cams for distribution to FIVE ZONES

Heavy Duty 26" by 18" diameter rotational molded basin, 26" lid, gasket pack, and security screws. Inline quick disconnect shut-off and quick disconnect on outgoing lines; and K-RAIN 6600 Indexing valve. Metal Die-Cast Body – Durable, long lasting and capable of high pressure applications. Operates at 15 GPM (57 LPM) at Pressures of 25–150 PSI (1,7-10,3 bar). Two Year Limited Warranty.



PDS-DV-6404-AP

Pre-Assembled 6000 Series K-Rain Valve W/4 Outlets + 4 Cams for distribution to FOUR ZONES

Heavy Duty 26" by 18" diameter rotational molded basin, 26" lid, gasket pack, and security screws. Inline quick disconnect shut-off and quick disconnect on outgoing lines; and K-RAIN 6400 Indexing valve. Metal Die-Cast Body – Durable, long lasting and capable of high pressure applications. Operates at 15 GPM (57 LPM) at Pressures of 25–150 PSI (1,7-10,3 bar). Two Year Limited Warranty.

DISTRIBUTION VALVES

SERIES 6000 HEAVY DUTY/HIGH PRESSURE

Part#/Description



PDS-DV-6403-AP

Pre-Assembled 6000 Series K-Rain Valve W/4 Outlets + 3 Cams for distribution to THREE ZONES

Heavy Duty 26" by 18" diameter rotational molded basin, 26" lid, gasket pack, and security screws. Inline quick disconnect shut-off and quick disconnect on outgoing lines; and K-RAIN 6400 Indexing valve. Metal Die-Cast Body – Durable, long lasting and capable of high pressure applications. Operates at 15 GPM (57 LPM) at Pressures of 25–150 PSI (1,7-10,3 bar). Two Year Limited Warranty.



PDS-DV-6402-AP

Pre-Assembled 6000 Series K-Rain Valve W/4 Outlets + 2 Cams for distribution to TWO ZONES

Heavy Duty. 26" by 18" diameter rotational molded basin, 26" lid, gasket pack, and security screws. Inline quick disconnect shut-off and quick disconnect on outgoing lines; and K-RAIN 6400 Indexing valve. Metal Die-Cast Body – Durable, long lasting and capable of high pressure applications. Operates at 15 GPM (57 LPM) at Pressures of 25–150 PSI (1,7-10,3 bar). Two Year Limited Warranty.

FILTERED PUMP VAULTS for STEP SYSTEMS

Part#/Description



FPV-H36-4, FPV-H44-4, FPV-H50-4, FPV-H56-4, FPV-H62-4, FPV-H68-4, FPV-H84-4, FPV-H96-4, FPV-H102-4.

Filtered Pump Vaults (Hanging)

- Hanging filtered pump vault installs into primary or pump tanks
- Protects pump and disposal field from solids larger than 1/16"
- All models available with 4 filter plates
- Includes maintenance plate for servicing ease
- Available in 36", 44", 50", 56", 62", 68", 84", 96", and 102" hanging lengths

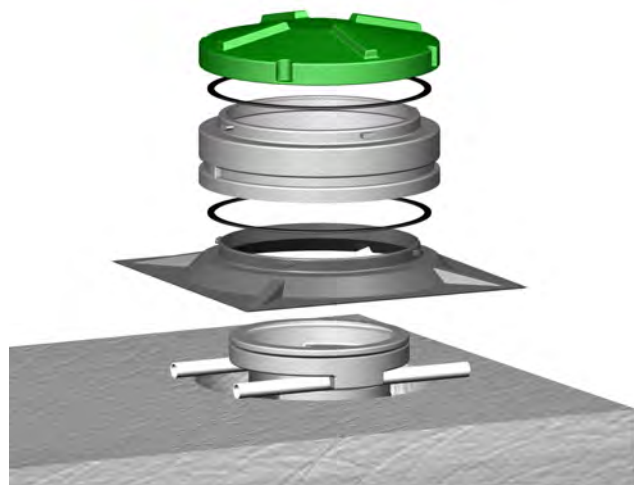
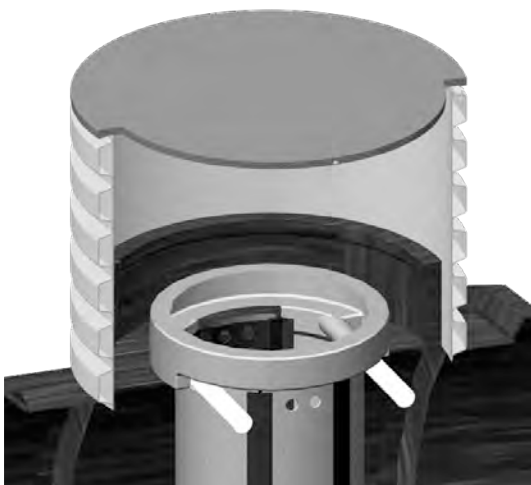

GROMMETS

Part#/Description



PDS-GT-.50-SCH40; PDS-GT-1.00-SCH40; PDS-GT-1.25-SCH40; PDS-GT-1.5-SCH40

1/2", 1", 1-1/4", and 1-1/5" schedule 40 grommets. Easy to install and watertight fit for pressurized installations.



PDS-GT-2.0-SCH40; PDS-GT-3.0-SCH40; PDS-GT-4.0-SCH40; PDS-GT-4.0-SDR35; PDS-GT-6.0-SCH35

2", 3" and 4" schedule 40 and 4" SCH 40 & SDR35; and 6" SH 35 grommets. The 2" grommet is for pressurized or gravity installations, and the 3", 4" and 6" grommets are primarily for gravity installations.

ORIFICE SHIELDS

Part#/Description



PDS-ZOS-075; PDS-ZOS-100; PDS-ZOS-125/150; PDS-ZOS-200

Orifice shields are commonly used in LPP systems and sand filter laterals. They snap tightly onto 3/4", 1", 1 1/4", 1 1/2", and 2" Schedule 40 pipe. The orifice shields fit snugly into place and can be installed either on top of the pipe or on the bottom of the pipe. Each shield contains slots to properly and adequately disperse the pressurized flow. Orifice Shields are molded in a process that assures uniform parts time after time. The ends are enclosed to protect from soil or media intrusion and a unique internal weir that reduces short-circuiting and provides for even flow.

FLOW DIVIDER/DIRECTOR

Part#/Description



GDS-Z300; GDS-Z300D

Drainfield Distribution Line Flow Dividers/Directors













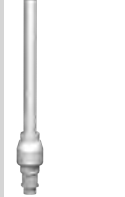

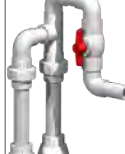

Flow Divider: GDS-Z300 utilizes a central weir to divide effluent evenly between two openings under gravity flow conditions. Easily installs directly to SCH 40 or SDR 35 pipe. May be installed in series to evenly distribute effluent to multiple lines.

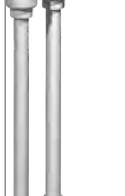
Flow Director: GDS-Z300D is ideal for alternating flows between two separate fields with a turn of the internal dial. Easily installs by attaching directly to SCH 40 or SDR 35 pipe. Central weir design protects from hydraulic overload by allowing effluent to bypass to the unused field.

The VERSA TEE design allows attachment to either 4" SDR 35 or SCH 40 pipe. Monitoring hub may be extended to grade for easy viewing and adjustments.

EFFLUENT DISCHARGE - STANDARD









Part#/Description

		SIMPLEX	DUPLEX	
SCH 40	HIGH HEAD	 <p>1-1/4" PDS-ED-S40-HH-1.25 Simplex SCH 40 High Head 1.25"</p>	 <p>1-1/4" PDS-ED-S40-HH-1.25-D Duplex SCH 40 High Head 1.25"</p>	
		 <p>1-1/2" PDS-ED-S40-HH-1.5 Simplex SCH 40 High Head 1.5"</p>	 <p>1-1/2" PDS-ED-S40-HH-1.5-D Duplex SCH 40 High Head 1.5"</p>	
		 <p>2.0" PDS-ED-S40-HH-2.0 Simplex SCH 40 High Head 12.0"</p>	 <p>2.0" PDS-ED-S40-HH-2.0-D Duplex SCH 40 High Head 2.0"</p>	
	LOW HEAD	 <p>1-1/4" PDS-ED-S40-LH-1.25 Simplex - SCH 40 - Low Head - 1.25"</p>	 <p>1-1/4" PDS-ED-S40-LH-1.25-D Duplex - SCH 40 - Low Head - 1.25"</p>	
		 <p>1-1/2" PDS-ED-S40-LH-1.5 Simplex - SCH 40 - Low Head - 1.5"</p>	 <p>1-1/2" PDS-ED-S40-LH-1.5-D Duplex - SCH 40 - Low Head - 1.5"</p>	
		 <p>2.0" PDS-ED-S40-LH-2.0 Simplex - SCH 40 - Low Head - 2.0"</p>	 <p>2.0" PDS-ED-S40-LH-2.0-D Duplex - SCH 40 - Low Head - 1.5"</p>	
	DRAIN BACK	 <p>1-1/4" PDS-ED-S40-DB-1.25 Simplex - SCH 40 - Drain Back - 1.25"</p>	 <p>1-1/4" PDS-ED-S40-DB-1.25-D. Duplex - SCH 40 - Drain Back - 1.25"</p>	
		 <p>1-1/2" PDS-ED-S40-DB-1.5 Simplex - SCH 40 - Drain Back - 1.5"</p>	 <p>1-1/2" PDS-ED-S40-DB-1.5-D. Duplex - SCH 40 - Drain Back - 1.5"</p>	
		 <p>2.0" PDS-ED-S40-DB-2.0 Simplex - SCH 40 - Drain Back - 2.0"</p>	 <p>2.0" PDS-ED-S40-DB-2.0-D. Duplex - SCH 40 - Drain Back - 2.0"</p>	

NOTE: The vertical piece(s) of pipe must be furnished and cut by the installer and is not included in the discharge kit.





EFFLUENT DISCHARGE - HEAVY DUTY

Part#/Description

		SIMPLEX			DUPLEX		
SCH 80	HIGH HEAD		1-1/4"	PDS-ED-S80-HH-1.25. Simplex - SCH 80 - High Head - 1.25"		1-1/4"	PDS-ED-S80-HH-1.25-D. Duplex - SCH 80 - High Head - 1.25"
			2.0"	PDS-ED-S80-HH-2.0. Simplex - SCH 80 - High Head - 2.0"		2.0"	PDS-ED-S80-HH-2.0-D. Duplex - SCH 80 - High Head - 2.0"
	DRAIN BACK		1-1/4"	PDS-ED-S80-DB-1.25. Simplex - SCH 80 - Drain Back - 1.25"		1-1/4"	PDS-ED-S80-DB-1.25-D. Duplex - SCH 80 - Drain Back - 1.25"
			2.0"	PDS-ED-S80-DB-2.0. Simplex - SCH 80 - Drain Back - 2.0"		2.0"	PDS-ED-S80-DB-2.0-D. Duplex - SCH 80 - Drain Back - 2.0"

NOTE: The vertical piece(s) of pipe must be furnished and cut by the installer and is not included in the discharge kit.

ACCESSORIES

	<p>LOW PRESSURE EXTERNAL FLEX</p> <p>PDS-ED-EFE-1.25; PDS-ED-EFE-1.5; PDS-ED-EFE-2.0</p>		<p>COLD WEATHER KITS</p> <p>PDS-ED-S40-CWK-1.25; PDS-ED-S40-CWK-1.5; PDS-ED-S40-CWK-2.0</p>
	<p>HIGH PRESSURE EXTERNAL FLEX</p> <p>ED-EFE-HP-1.25; PDS-ED-EFE-HP-2.0</p>		<p>PDS-ED-S80-CWK-1.25; PDS-ED-S80-CWK-1.5; PDS-ED-S80-CWK-2.0</p>

LIDS, RISERS & ADAPTERS (Heavy Duty Polyethylene)

22" Diameter

Part#/Description

26" Diameter

Part#/Description

RB-L-22



22" Diameter Heavy Duty Polyethylene Lid

Heavy Duty polyethylene lid with proprietary twist and lock feature, tamper resistant stainless steel fasteners, neoprene gasket.

RB-L-26



26" Diameter Heavy Duty Polyethylene Lid

Heavy Duty polyethylene lid with proprietary twist and lock feature, tamper resistant stainless steel fasteners, neoprene gasket with two year limited warranty.

RB-R-22X6



22" Diameter X 6" High Heavy Duty Polyethylene Riser

Heavy Duty polyethylene riser with proprietary twist and lock feature, neoprene gasket.

RB-R-26X6



26" Diameter X 6" High Heavy Duty Polyethylene Riser

Heavy Duty polyethylene riser with proprietary twist and lock feature, neoprene gasket with two year limited warranty.

RB-R-22X12



22" Diameter X 12" High Heavy Duty Polyethylene Riser

Heavy Duty polyethylene riser with proprietary twist and lock feature, neoprene gasket

RB-R-26X12



26" Diameter X 12" High Heavy Duty Polyethylene Riser

Heavy Duty polyethylene riser with proprietary twist and lock feature, neoprene gasket with two year limited warranty.

RB-RTA-22X2



22" Diameter X 2" High Heavy Duty Polyethylene Tank Adapter

Heavy Duty polyethylene concrete tank adapter with proprietary twist and lock feature, neoprene gasket with two year limited warranty.

RB-R-26X18



26" Diameter X 18" High Heavy Duty Polyethylene Riser

Heavy Duty polyethylene riser with proprietary twist and lock feature, neoprene gasket, two year limited warranty.

RB-R-26x38



26" Diameter X 38" High Heavy Duty Polyethylene Riser

Heavy Duty polyethylene riser with proprietary twist and lock feature, neoprene gasket with two year limited warranty.

RB-RTA-26X2



26" x 2" Retrofit Tank Adapter

Heavy Duty polyethylene concrete tank adapter with proprietary twist and lock feature, neoprene gasket, two year limited warranty.

BASINS (Heavy Duty Polyethylene)

22" BASIN ASSEMBLIES

Part#/Description



RB-BAS-22X12

22" Diameter X 12" High Heavy Duty Polyethylene Basin Assembly

Heavy Duty polyethylene Basin Assembly with proprietary twist and lock feature, 22" x 12" basin, plus 22" lid with neoprene gasket & stainless steel screw pack, and two 1-1/4" SCH 40 grommets. This product features a two year limited warranty.

26" BASIN ASSEMBLIES

Part#/Description



RB-BAS-26X12

26" Diameter X 12" High Heavy Duty Polyethylene Basin Assembly

Heavy Duty polyethylene Basin Assembly with proprietary twist and lock feature, 22" x 12" basin, plus 26" lid with neoprene gasket & stainless steel screw pack, and two 1-1/4" SCH 40 grommets. This product features a two year limited warranty.



RB-BAS-26X18

26" Diameter X 18" High Heavy Duty Polyethylene Basin Assembly

Heavy Duty polyethylene Basin Assembly with proprietary twist and lock feature, 26" X 18" basin, plus 26" lid with neoprene gasket & stainless steel screw pack, and two 1-1/4" SCH 40 grommets. This product features a two year limited warranty.



RB-BAS-26X38

22" Diameter X 12" High Heavy Duty Polyethylene Basin Assembly

Heavy Duty polyethylene Basin Assembly with proprietary twist and lock feature, 22" x 12" basin, plus 22" lid with neoprene gasket & stainless steel screw pack, and two 1-1/4" SCH 40 grommets. This product features a two year limited warranty.

MISC PARTS FOR 22" & 26" LIDS, RISERS, ADAPTERS, & BASINS

Part Number

Description

RB-GAS-22/26

22"/26" Gasket Pack: Neoprene gasket pack for 22" or 26" diameter risers/lids

RB-LS-22/26

22"/26" Screw Pack: Stainless steel screw pack for 22" or 22" diameter risers/lids

RB-BUTSEA

BUTYL Sealant: We recommend the use of a butyl sealant between risers to reduce the possibility of water intrusion.

Purchase Terms and Warranty

The following Purchase Terms and Warranty apply to all sales of products by Quanics. Your purchase of Quanics products is confirmation of your acceptance. The Purchase Terms and Warranty may be changed solely at the discretion of Quanics without notice.

Quotes:

Project estimates are valid for 90 days unless otherwise noted by Quanics. Individual part prices are subject to change without notice.

Payment Terms:

Open Accounts: Net 30 days. 1 1/2% charged on accounts for each month or portion thereof that are past 30 days. Timely payments are very important and this late fee will be charged to all accounts that are paid late. Accounts past due on a continuous or reoccurring basis may have their credit approval status modified without prior notification. All Credit Card charges will incur a 3% processing fee. There is a \$50.00 fee for returned checks.

Product Returns:

Returns require prior approval. Product may be returned within 30 days of invoice date for full refund if returned in undamaged, unopened box. Damaged box voids any return refund. A 20% restocking fee will be charged if boxes opened and resealed or return is made after 30 but within 90 days of purchase. Returns after 90 days will be on a case by case basis. Custom items are nonreturnable. All freight will be charged to the customer's account.

Freight:

All products are sold F.O.B. Quanics warehouse or F.O.B. the original equipment manufacturer. Additional charges may be incurred for multiple drop shipments, haulers fuel surcharge or special delivery conditions such as residential surcharges for pallet offloading. Choice of freight carrier is at the discretion of Quanics. Customers requesting specific carriers or delivery types will be responsible for any additional freight charges.

Customer Responsible for Damaged Shipments:

Freight claims for damaged or missing shipments are the responsibility of the customer. Shipping claims shall be filed by the customer with the delivering carrier and any losses incurred are at the customer's expense. If you receive a shipment in damaged condition, retain all packing material for carrier's examination, immediately advise the carrier by phone and in writing, and advise our office immediately so we may assist you with your carrier claim.

State Sales Tax:

All purchases made within the state of Kentucky will be charged the appropriate rate of Kentucky sales tax. Sales or use tax of out of state orders are the responsibility of the customer and such purchases will be reported to the respective state when requested.

Warranty:

- All products manufactured by Quanics are warranted against defects in material and workmanship for a period of one year from the date purchased unless a longer period is stated on the product Technical Data Sheet.
- Quanics' liability is limited to repair or replacement of the part. In no event shall Quanics be liable for any consequential damages or any labor, material, freight or other expense required to replace, correct, or reinstall the product.
- Warranty is void if the product has been improperly modified, applied, installed, or subjected to abuse or misuse.
- Except as stated herein, there are no warranties expressed or implied including the warranty of merchantability or warranty of fitness for a specific purpose.
- Products bought and resold by Quanics carry the original manufacturer's warranty in lieu of any warranty provided by Quanics. Quanics will assist the customer in processing a warranty claim for products resold by Quanics, but is not responsible for the warranty provided by the original manufacturer or the failure of the original manufacturer to honor the terms of their warranty.