

See Video: [A Clean Grounding Spot in the Yard](https://www.brighteon.com/d1e3b6b9-c934-4675-b9d8-cb424eaa92ae)

<https://www.brighteon.com/d1e3b6b9-c934-4675-b9d8-cb424eaa92ae>

This is to try and explain the larger circuit of primary return current and how it flows through the home.

I call this foreign current because there is no breaker in our panel that will stop it.

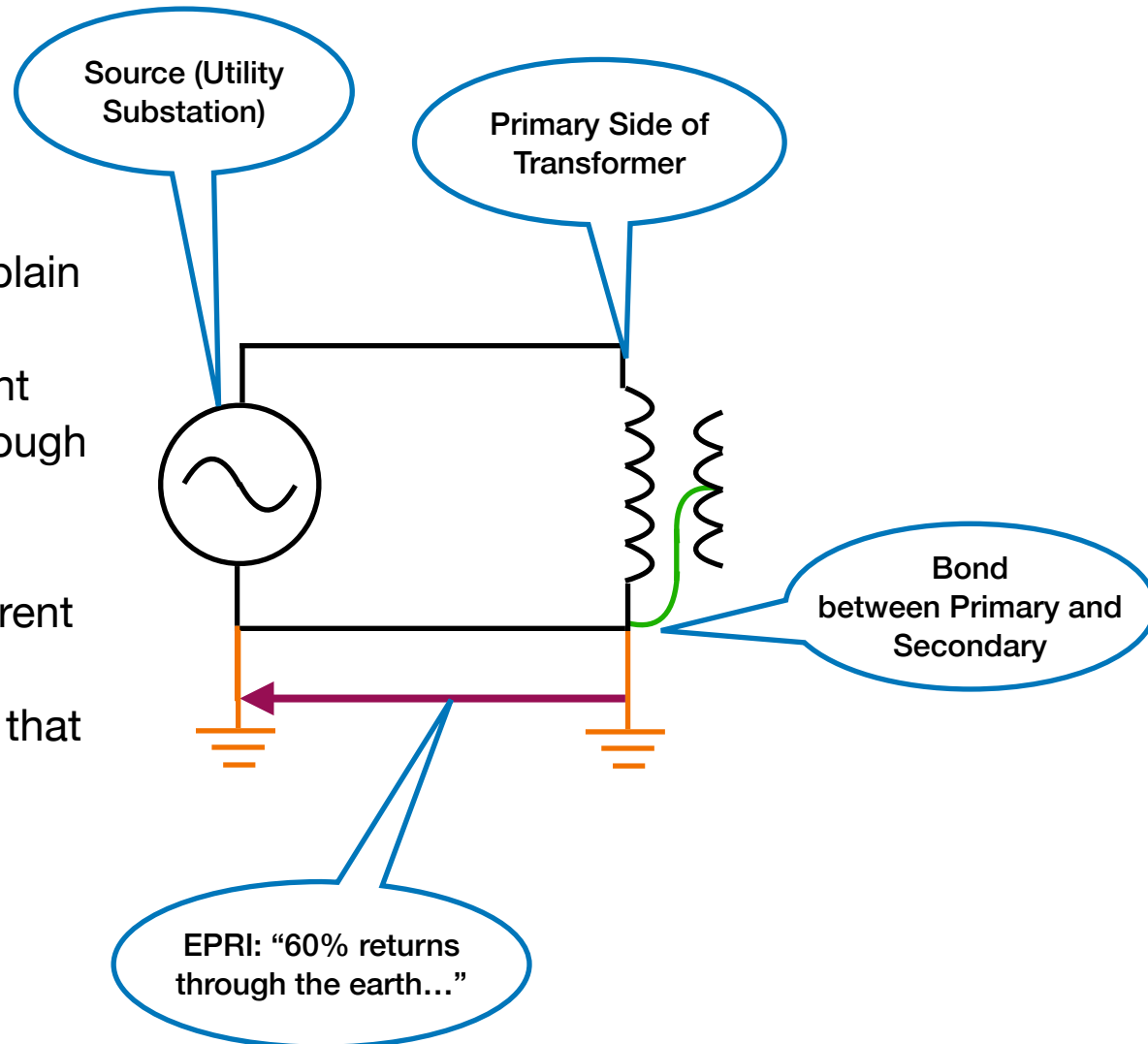

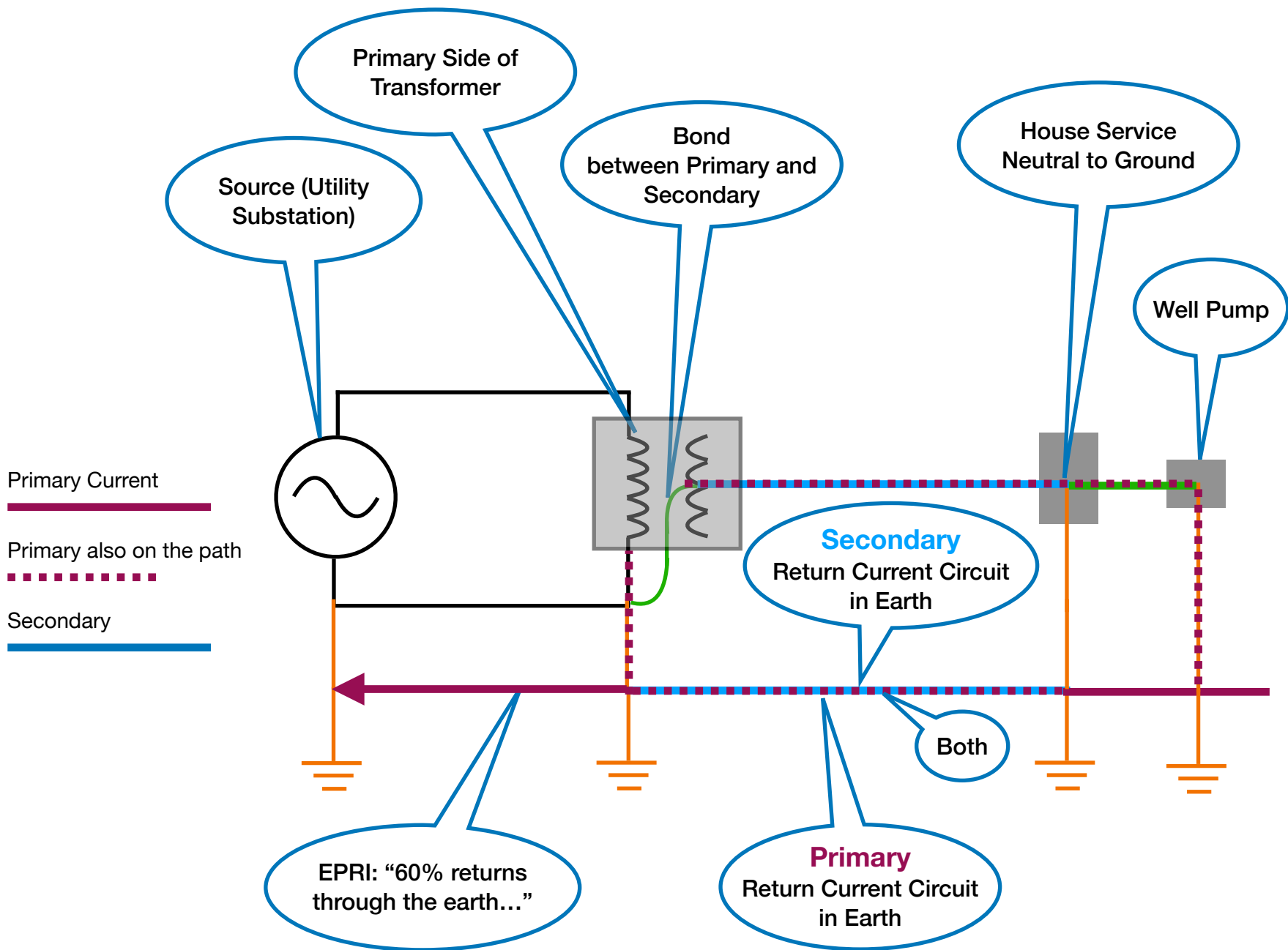

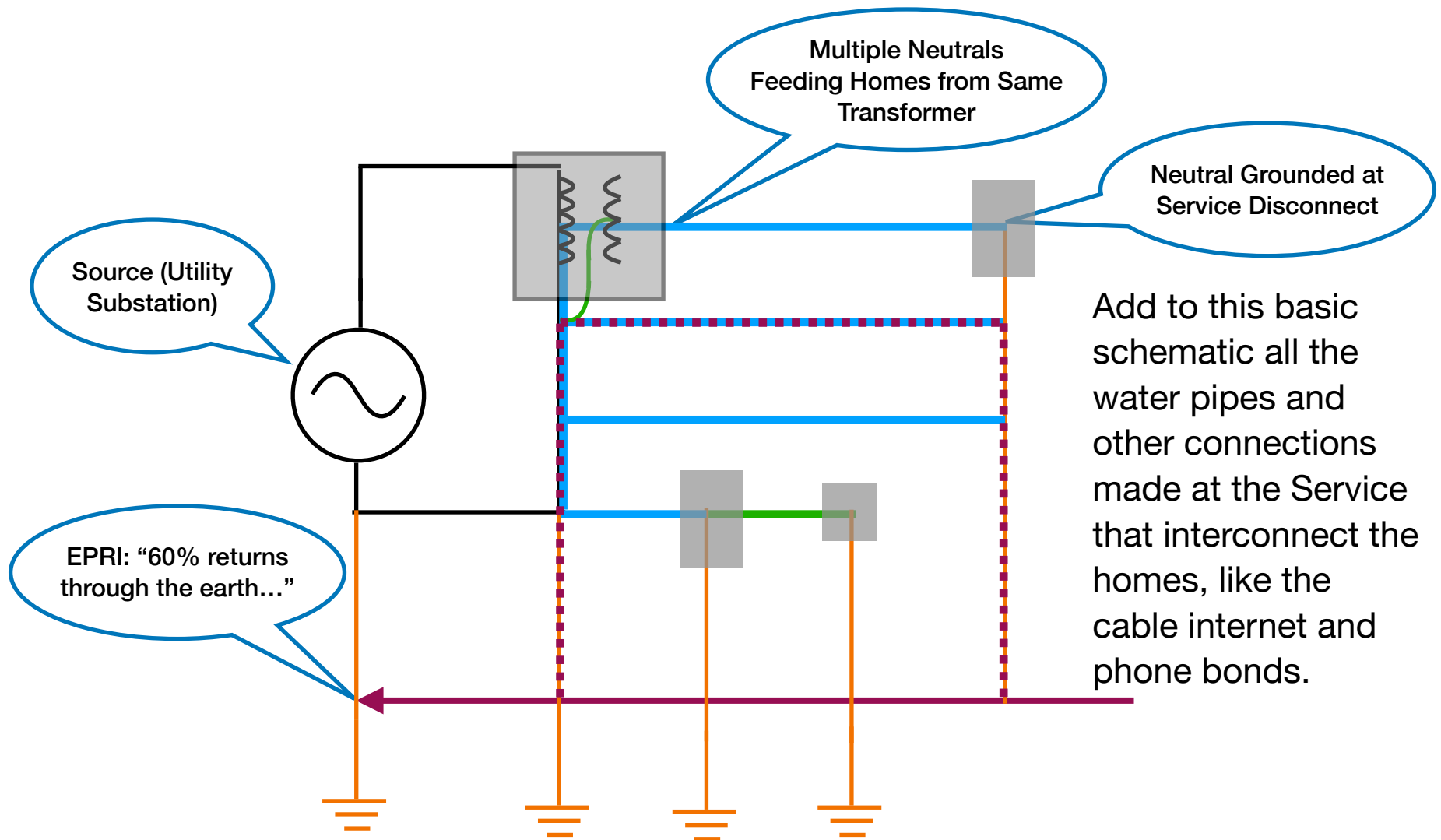

Current traveling through the soil. See [video](#).

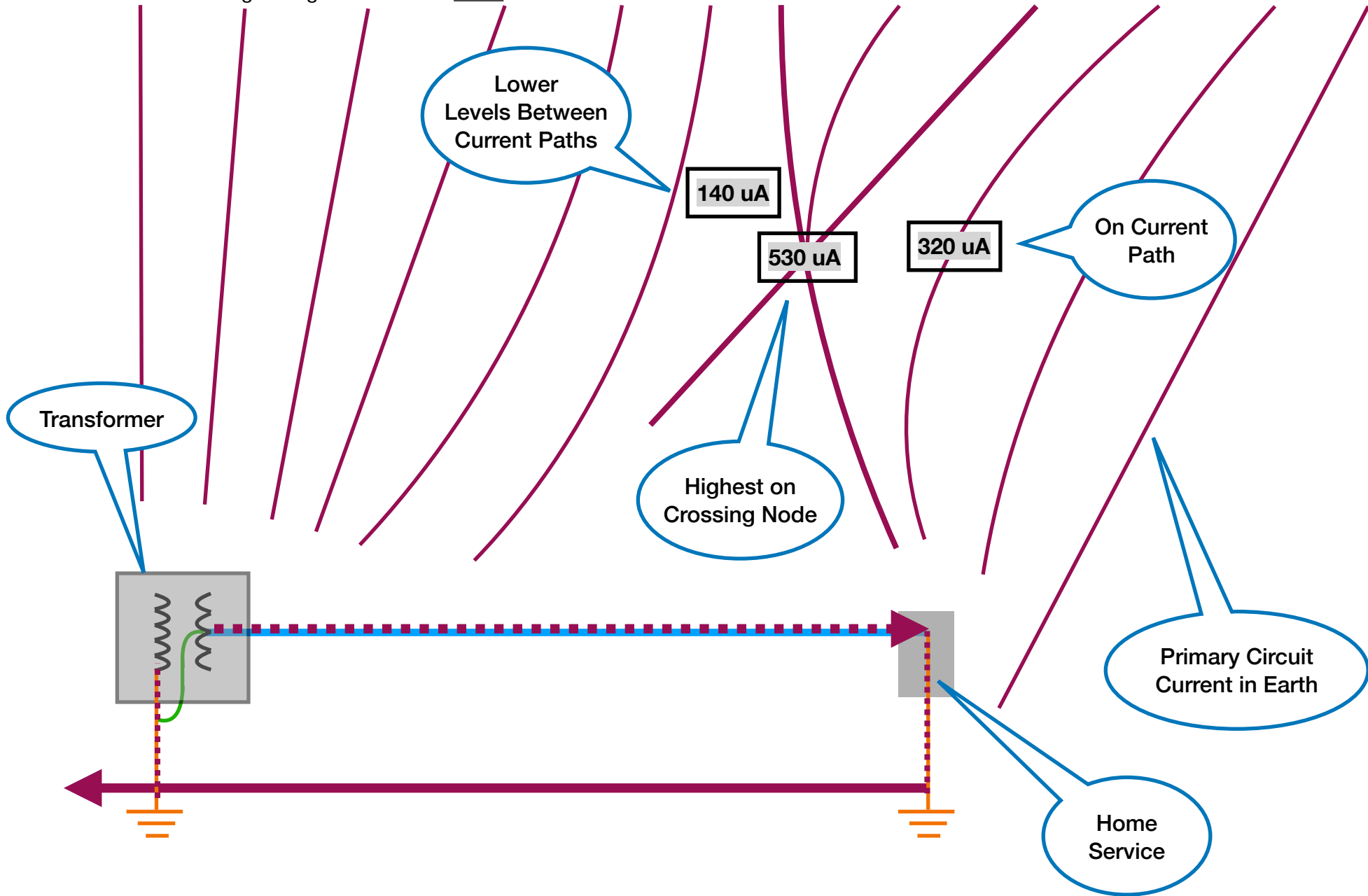

Only one current flow path is shown here (red arrows) but imagine how many there can be making loops between appliances, on the water and gas pipes, and especially on anything that connects back to the earth. Not shown are all the paths throughout the equipment grounding conductor system in branch circuit outlets and lighting systems. These all create magnetic fields in the home and higher contact current conditions.

