

---

# New Buck Corporation

Project # 19-519

Model: 74

Type: Wood-Fired Room Heater

November 5, 2019

---

**ASTM E3053 Standard Test  
Method for Determining  
Particulate Matter Emissions from  
Wood Heaters Using Cordwood  
Test Fuel (EPA ALT-125)**

---

Contact: Mr. Brian Schwock  
200 Ethan Allen Drive  
Spruce Pine, NC 28777  
bschwock@buckstove.com  
828-765-6144

---

Prepared by: Aaron Kravitz, Testing  
Supervisor

---



**11785 SE Highway 212 – Suite 305**

**Clackamas, OR 97015-9050**

**(503) 650-0088**

**[WWW.PFSTECO.COM](http://WWW.PFSTECO.COM)**

This page intentionally left blank.

## Contents

Affidavit .....	3
Introduction .....	4
Notes .....	4
Wood Heater Identification and Testing .....	5
Test Procedures and Equipment .....	6
Results .....	7
Summary Table .....	7
Test Run Narrative .....	8
Run 1 .....	8
Run 2 .....	8
Run 3 .....	8
Test Conditions Summary .....	9
Appliance Operation and Test Settings .....	9
Settings & Run Notes .....	9
Appliance Description .....	10
Appliance Dimensions .....	10
Test Fuel Properties .....	13
Sampling Locations and Descriptions .....	14
Sample Points .....	14
Sampling Methods .....	15
Analytical Methods Description .....	15
Calibration, Quality Control and Assurances .....	15
Appliance Sealing and Storage .....	15
Sealing Label .....	15
Sealed Unit .....	16
List of Appendices .....	17

## Affidavit

PFS-TECO was contracted by New Buck Corporation to provide testing services for the 74 Wood-Fired Room Heater per ASTM E3053, *Standard Test Method for Determining Particulate Matter Emissions from Wood Heaters Using Cordwood Test Fuel*, which was approved for use under EPA ALT-125. All testing and associated procedures were conducted at Nelke Consulting LLC beginning on 10/8/2019 and ending on 10/9/2019. Nelke Consulting's laboratory is located at 30522 SE Leavenworth Ct, Eagle Creek, OR 97022. Testing procedures followed ASTM E3053, with variances as described in EPA ALT-125. Particulate sampling was performed per ASTM E2515, *Standard Test Method for Determination of Particulate Matter Emissions Collected by a Dilution Tunnel*, with the exception of caveats described in EPA ALT-125. A copy of EPA ALT-125 is included in Appendix A for reference, as required by the approval letter.

PFS-TECO is accredited by the U.S. Environmental Protection Agency for the certification and auditing of wood heaters pursuant to subpart AAA of 40 CFR Part 60, New Source Performance Standards for Residential Wood Heaters and subpart QQQQ of 40 CFR Part 60, Standards of Performance for New Hydronic Heaters and Forced Air Furnaces, Methods 28R, 28WHH, 28 WHH-PTS, and all methods listed in Sections 60.534 and 60.5476. PFS-TECO holds EPA Accreditation Certificate Numbers 4 and 4M (mobile). PFS-TECO is accredited by IAS to ISO 17020:2012 "Criteria for Bodies Performing Inspections", and ISO 17025:2005 "Requirements for Testing Laboratories." PFS-TECO is also accredited by Standards Council of Canada to ISO 17065:2012 "Requirements for Bodies Operating Product Certification Systems."

The following people were associated with the testing, analysis and report writing associated with this project.

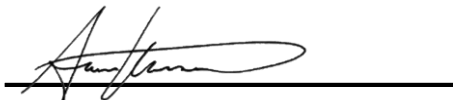

Aaron Kravitz, Testing Supervisor

## Introduction

New Buck Corporation of Spruce Pine, NC contracted with PFS-TECO to perform EPA certification testing on the model 74 Wood-Fired Room Heater. All testing was performed at Nelke Consulting LLC in Eagle Creek, OR. All testing was performed by Aaron Kravitz.

## Notes

- Prior to start of testing, 50 hours of conditioning was performed per ASTM E3053.
- Prior to start of testing, the dilution tunnel was cleaned with a steel brush.
- Front filters were changed on sample train A at one hour for all 3 test runs.
- A total of 3 test runs were completed. Test runs were performed in accordance with ASTM E3053. For the three test runs used in the weighted average, no anomalies occurred. See the Run Narrative section for further detail on each run.

## Wood Heater Identification and Testing

- Appliance Tested: **74**
- Serial Number: ***Un-serialized Prototype – PFS Tracking Number 0042***
- Manufacturer: ***New Buck Corporation***
- Catalyst: ***No***
- Heat exchange blower: ***Optional***
- Type: ***Wood Stove***
- Style: ***Free Standing***
- Date Received: ***Monday, October 07, 2019***
- Testing Period – Start: ***Tuesday, October 08, 2019***  
Finish: ***Wednesday, October 09, 2019***
- Test Location: ***Nelke Consulting LLC***  
***30522 SE Leavenworth Ct, Eagle Creek, OR***
- Elevation: ***~500 Feet above sea level***
- Test Technician(s): ***Aaron Kravitz***
- Observers: ***Gary Nelke of Nelke Consulting.***

## Test Procedures and Equipment

All Sampling and analytical procedures were performed by Aaron Kravitz. All procedures used are directly from ASTM E3053 and ASTM E2515. See the list below for equipment used. See Appendix C submitted with this report for calibration data.

### Equipment List:

Equipment ID#	Equipment Description
N/A	United 3'x3' floor scale w/digital weight indicator
050	Digiweigh DWP12i Platform Scale
053	APEX XC-60 Digital Emissions Sampling Box A
054	APEX XC-60 Digital Emissions Sampling Box B
057	California Analytical ZRE CO <sub>2</sub> /CO/O <sub>2</sub> IR ANALYZER
064	Digital Barometer
109A/B	Troemner 100mg/200mg Audit Weights
107	Sartorius Analytical Balance
051	10 lb audit weight
090	Dewalt Tape Measure
092	Digital Calipers
095	Anemometer
111	Microtector
115	Delmhorst Wood Moisture Meter
CC50101	Gas Analyzer Calibration Span Gas
BSG-00543	Gas Analyzer Calibration Zero Gas

## Results

The weighted average emissions rate for the 3 run test series was measured to be **1.78 g/hr** with a Higher Heating Value efficiency of **73%\***. The average CO emission rate for the 3 tests was **1.64 g/min**. The New Buck Corporation model 74 Wood-Fired Room Heater meets the 2020 cordwood PM emission standard of  $\leq 2.5$  g/hr per CFR 40 part 60, §60.532 (c).

Detailed individual run data can be found in Appendix A submitted with this report.

### Summary Table

	High Fire Test	Low Fire Test	Medium Fire Test
Date	10/8/2019	10/8/2019	10/9/2019
Run Number	1	2	3
PM Emission Rate (g/hr)	4.05	1.61	0.81
Burn Rate (kg/hr)	3.79	0.96	1.15
Heat Output (BTU/hr)	52,400	13,300	16,100
HHV Efficiency (%)	71.0%	73.6%	74.6%
LHV Efficiency (%)	76.0%	78.7%	79.8%
CO Emissions (g/MJ output)	1.62	7.68	5.77
CO Emissions (g/kg dry fuel)	23.01	112.78	85.97
CO Emissions (g/min)	1.49	1.80	1.63
1 <sup>st</sup> Hour Emission Rate (g/hr)	3.31	6.84	5.32
Weighting Factor (%)	20%	40%	40%
<b>Weighted particulate emission average of 3 test runs: 1.78 grams per hour.</b>			
<b>Weighted average HHV efficiency of 3 test runs: 73.5%*.</b>			
<b>Average CO emission rate for 3 test runs: 1.64 grams per minute</b>			

*\*Per PFS TECO's Quality Control Manual, all significant figures are carried through calculations and reported for intermediate results. The computed weighted average efficiency of 73.47% is therefore represented as 73.5% in the table above but reported as 73% (as required by ASTM E3053) in the text.*



## Test Run Narrative

### *Run 1*

Run 1 was performed on 10/8/2019 as a high fire test run per ASTM E3053. Emissions sampling began from a cold start ignition of kindling and start-up fuel. The test fuel load was loaded 32 minutes into the test. Testing was completed when 90% of the test fuel load was consumed. Total test time was 137 minutes, main test fuel load burn time was 105 min. The particulate emissions rate from kindling ignition to test completion was 4.05 g/hr. The burn rate of the test fuel load was 3.79 kg/hr. The main test load portion of the run had an overall HHV efficiency of 71.0%. The train A front filter was changed at 1 hr. All test results were appropriate and valid. There were no anomalies and all test criteria were met.

### *Run 2*

Run 2 was performed on 10/8/2019 as a low fire test run per ASTM E3053. The overall test duration was 570 minutes. The burn rate for the test run was 0.96 kg/hr. The particulate emissions rate for the test run was 1.61 g/hr. The run had an overall HHV efficiency of 73.6%. The train A front filter was changed at 1 hr. All test results were appropriate and valid. There were no anomalies and all test criteria were met.

### *Run 3*

Run 3 was performed on 10/9/2019 as a medium fire test run per ASTM E3053. The overall test duration was 465 minutes. The burn rate for the test run was 1.15 kg/hr, therefore the medium fire category requirements were met, less than the mid-point of the high and low burn rates (2.38 kg/hr). The particulate emissions rate for the test run was 0.81 g/hr. The run had an overall HHV efficiency of 74.6%. The train A front filter was changed at 1 hr. There were no anomalies and all criteria were met.

## Test Conditions Summary

Testing conditions for all runs fell within allowable specifications of ASTM E3053 and ASTM E2515. A summary of facility conditions, fuel burned, and run times is listed below.

Runs	Ambient (°F)		Relative Humidity (%)		Average Barometric Pressure (In. Hg.)	Preburn Fuel Weight (lbs)	Test Fuel Weight (lbs)	Test Fuel Moisture (%DB)	Test Run Time (Min)
	Pre	Post	Pre	Post					
1	66	73	52.6	43.6	29.98	10.01 <sup>1</sup>	20.81	24.6%	137 <sup>2</sup>
2	76	64	41.8	46.3	30.04	20.81	24.87	24.3%	570
3	68	66	38.6	26.8	30.22	20.93	24.53	24.3%	465

<sup>1</sup>This is the weight of the kindling and startup fuel

<sup>2</sup>Total test time was 137 min, high fire test load burn duration was 105 min.

## Appliance Operation and Test Settings

The appliance was operated according to procedures as described in the Operations Manual, found in Appendix B submitted with this report. Detailed run information can be found in Appendix A submitted with this report.

## Settings & Run Notes

	Pre-Burn Air Setting	Test Run Air and Fan Settings
<b>Run 1</b>	N/A – Cold Start Ignition	Air control set to high fire test setting, blower set to high
<b>Run 2</b>	Air control set to High Fire Setting in accordance with ASTM E3053	Air control set to low fire test setting at 13 minutes. Blower off for first 1.5 min, then set to low.
<b>Run 4</b>	Air control set to High Fire Setting in accordance with ASTM E3053	Air control set to medium fire test setting at 10 minutes. Blower off for first minute, then set to medium.

## Appliance Description

**Model(s):** 74

**Appliance Type:** Wood-Fired Room Heater

**Firebox Volume:** 2.15 ft<sup>3</sup>

**Air Introduction System:** Primary Air enters the firebox from the front bottom of the appliance and is channeled up the sides on the appliance and down through the air wash, as well as through a pilot air opening in the front of the firebox. Primary air is controlled via a damper arm located below the ashlip which moves in (open) and out (closed). Secondary air is pulled through a fixed opening adjacent to the primary intake and channeled under the stove and up through 4 secondary air tubes. Dimensions on all these features can be found in Appendix D.

**Baffles:** A 22" x 13.0" x 0.50" vermiculite panel rests on top of the secondary air tubes.

**Refractory Insulation:** The firebox is lined with 1.25" thick firebrick.

**Flue Outlet:** 6-inch exhaust outlet located on the top of the appliance.

**Catalytic Combustor:** N/A

**Fan:** The 74 is available with a convection fan that attached to the lower front of the appliance.

### Appliance Dimensions

74 Unit Dimensions

Height	Width	Depth	Firebox Volume
22"	27.5"	22"	2.15 ft <sup>3</sup>

Appliance design drawings can be found in Appendix D submitted with the CBI copy of this report.

Appliance Front



Appliance Left



Appliance Right



Appliance Rear



## Test Fuel Properties

Test fuel used was Maple cordwood, split and air-dried to the specified moisture content range. Typical fuel loads are pictured below:

Typical Kindling Load



Typical Startup Load



Typical High Fire Load



Typical Low Fire Load



## Sampling Locations and Descriptions

Sample ports are located 16.5 feet downstream from any disturbances and 1 foot upstream from any disturbances. Flow rate traverse data was collected 12 feet downstream from any disturbances and 5.5 feet upstream from any disturbances. (See below).

### Sample Points

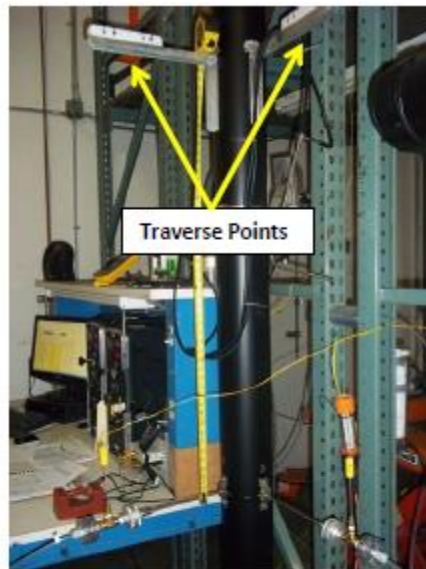
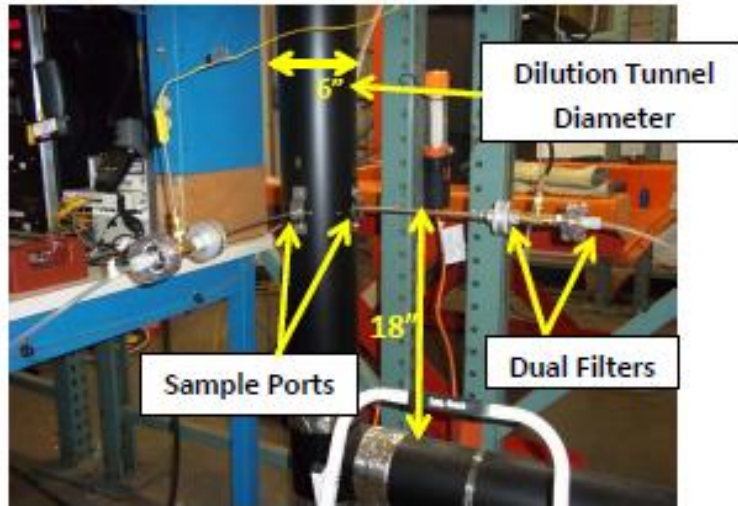

Figure 12: Traverse Points

## Sampling Methods

ASTM E2515 was used in collecting particulate samples. The dilution tunnel is 6 inches in diameter. All sampling conditions per ASTM E2515 were followed. No alternate procedures were used with the exception of caveats described in ALT-125: Pall TX40 Emfab filters were used, filter temperatures were maintained between 80 and 90°F for all tests, filters were weighed in pairs where applicable, and no sampling intervals fell outside of proportional rates of +/- 10%.

## Analytical Methods Description

All sample recovery and analysis procedures followed ASTM E2515 procedures. At the end of each test run, filters, O-Rings and probes were removed from their housings, dessicated for a minimum of 24 hours, and then weighed at 6 hour intervals to a constant weight per ASTM E2515-11 Section 10.

## Calibration, Quality Control and Assurances

Calibration procedures and results were conducted per EPA Method 28R, ASTM E2515-11 and ASTM E3053. Test method quality control procedures (leak checks, volume meter checks, stratification checks, proportionality results) followed the procedures outlined.

## Appliance Sealing and Storage

Upon completion of testing, the appliance was secured with metal strapping and the seal below was applied, the appliance was then returned to the manufacturer's location at: 200 Ethan Allen Drive, Spruce Pine, NC 28777 for archival.

### Sealing Label

#### **ATTENTION:**

THIS SEAL IS NOT TO BE BROKEN WITHOUT PRIOR AUTHORIZATION FROM THE  
UNITED STATES ENVIRONMENTAL PROTECTION AGENCY.

THIS APPLIANCE HAS BEEN SEALED INACCORDANCE WITH REQUIREMNTS OF 40CFR  
PART 60 SUBPART AAA §60.535 (a)(2)(vii)

REPORT # _____	DATE SEALED _____
MANUFACTURER _____	MODEL # _____



### Sealed Unit



## List of Appendices

The following appendices have been submitted electronically in conjunction with this report:

Appendix A – Test Run Data, Technician Notes, Sample Analysis, and Alternate Test Method Approval

Appendix B – Labels and Manuals

Appendix C – Equipment Calibration Records

Appendix D – Design Drawings (CBI Report Only)

Appendix E – Manufacturer QAP (CBI Report Only)

## WOOD HEATER TESTING SUMMARY

### SECTION 1 – Model Identification

Model Name(s)/Number(s)  
Manufacturer  
Address 1  
Address 2  
Appliance Category(s) (Free-standing, Insert, etc.)  
Usable Firebox Volume - ft<sup>3</sup>  
Catalytic/Non-Cat  
Convection Air Fan (No, Standard, Optional)

74  
New Buck Corporation  
P.O. BOX 69  
Spruce Pine, NC 29777  
Free-standing  
2.15  
Non-Cat  
Standard

### SECTION 1B – Laboratory Information

Testing Laboratory  
Address 1  
Address 2  
ISO/Accreditation Info  
Dates Tested  
Test Methods/Standards  
Dilution Tunnel Inside Diameter - in.  
Filter Diameter - mm  
Filter Material

PFS-TECO  
11785 SE Hwy 212 Ste 305  
Clackamas, OR 97015  
ISO 17025  
10/8/19 - 10/9/19  
ASTM E3053 (ALT-125), ASTM E2515  
6.00  
47  
Pall Type TX40

**SECTION 2 – Test Conditions Summary**

Test Run #  
 Date Tested  
 Test Run Category (L, M, H)  
 Average Barometric Pressure - in Hg  
 Max. Observed Ambient Temp - °F  
 Min. Observed Ambient Temp - °F  
 Max. Observed Filter Temp - °F  
 Test Fuel Load  
     Cordwood Fuel Species  
     Specific Gravity (from Table 1)  
     Higher Heating Value - Btu/lb (from Annex A1)  
     Nom. Test Fuel Load Piece Length - in.  
     Number of Test Fuel Pieces  
 Test Fuel Weight  
     Kindling - As Fired lb  
     Kindling Wt. - As % of Test Fuel Load  
     Kindling Moisture - % DB  
     Kindling - kg DB  
     SU Fuel - As Fired lb  
     SU Fuel Wt. - As % of Test Fuel Load  
     SU Fuel Moisture - % DB  
     SU Fuel - kg DB  
     Test Fuel Load - As Fired lb  
     Ave. Test Fuel Load MC % DB  
     Test Fuel Load - kg DB  
 Test Fuel Loading Density - lb/ft3  
 Residual SU Fuel Wt. - As Fired lb  
 Residual SU Fuel Wt. - As % of Test Fuel Load  
 Test Run Duration - minutes  
 Test Run Duration - h  
 Run Duration of High Fire Load Only - minutes  
 Run Duration of High Fire Load Only - h  
 Test Fuel Load Wt. at End of Test - As Fired lb  
 Total Fuel Burned - kg DB  
 % Test Fuel Load Wt. at End of Test

	1	2	3
Test Run #	1	2	3
Date Tested	10/8/2019	10/8/2019	10/9/2019
Test Run Category (L, M, H)	High Fire	Low Fire	Medium Fire
Average Barometric Pressure - in Hg	29.98	30.04	30.22
Max. Observed Ambient Temp - °F	74	78	72
Min. Observed Ambient Temp - °F	66	64	66
Max. Observed Filter Temp - °F	88	90	90
Test Fuel Load			
Cordwood Fuel Species	Maple, Hard	Maple, Hard	Maple, Hard
Specific Gravity (from Table 1)	0.60	0.60	0.6
Higher Heating Value - Btu/lb (from Annex A1)	8587	8587	8587
Nom. Test Fuel Load Piece Length - in.	16	16	0
Number of Test Fuel Pieces	5	5	5
Test Fuel Weight			
Kindling - As Fired lb	3.99	N/A	N/A
Kindling Wt. - As % of Test Fuel Load	19.2%	N/A	N/A
Kindling Moisture - % DB	11.0%	N/A	N/A
Kindling - kg DB	1.63	N/A	N/A
SU Fuel - As Fired lb	6.02	N/A	N/A
SU Fuel Wt. - As % of Test Fuel Load	28.9%	N/A	N/A
SU Fuel Moisture - % DB	23.2%	N/A	N/A
SU Fuel - kg DB	2.22	N/A	N/A
Test Fuel Load - As Fired lb	20.81	24.87	24.53
Ave. Test Fuel Load MC % DB	24.6%	24.3%	24.3%
Test Fuel Load - kg DB	7.58	9.07	8.95
Test Fuel Loading Density - lb/ft3	9.6	11.5	11.41
Residual SU Fuel Wt. - As Fired lb	2.30	N/A	N/A
Residual SU Fuel Wt. - As % of Test Fuel Load	11.1%	N/A	N/A
Test Run Duration - minutes	137	570	465
Test Run Duration - h	2.28	9.50	7.75
Run Duration of High Fire Load Only - minutes	105	N/A	N/A
Run Duration of High Fire Load Only - h	1.75	N/A	N/A
Test Fuel Load Wt. at End of Test - As Fired lb	2.1	0.0	0.1
Total Fuel Burned - kg DB	9.43	9.07	8.90
% Test Fuel Load Wt. at End of Test	10.1%	0.0%	0.4%

**SECTION 3 – Test Run Results Summary**

Test Run #	1	2	3
Date Tested	10/8/19	10/8/19	10/9/19
Test Run Category	High Fire	Low Fire	Medium Fire
Burn Rate - kg/h DB	3.79	0.96	1.15
Heat Output - Btu/h	52,371	13,310	16,091
Average Dilution Tunnel Flow Rate - dscfm	197.8	212.2	207.97
Average Sample Flow Rates - dscfm			
Train 1	0.145	0.148	0.146
Train 2	0.141	0.146	0.143
Total PM Emissions - g			
Train 1	8.65	15.40	6.29
Train 2	9.85	15.20	6.22
Average	9.25	15.30	6.258
PM Emission Train Precision - %	6.5%	0.6%	0.6%
PM Emission Train Precision - g/kg	0.06	0.01	0.00
PM Emission Rate - g/h	4.05	1.61	0.81
Total CO Emissions - g	157	1,024	759
CO Emissions Rate - g/h	90	108	98
Overall Efficiency - CSA B415.1-10			
% HHV Basis	71%	74%	75%
% LHV Basis	76%	79%	80%

1	2	3	
10/8/19	10/8/19	10/9/19	
High Fire	Low Fire	Medium Fire	
3.79	0.96	1.15	
52,371	13,310	16,091	
197.8	212.2	207.97	
0.145	0.148	0.146	
0.141	0.146	0.143	
8.65	15.40	6.29	
9.85	15.20	6.22	
9.25	15.30	6.258	
6.5%	0.6%	0.6%	
0.06	0.01	0.00	
4.05	1.61	0.81	
157	1,024	759	
90	108	98	
71%	74%	75%	
76%	79%	80%	

**SECTION 4 - Weighted Average Summary**

Test Run Category	High Fire	Low Fire	Medium Fire
Burn Rate - kg/h DB	3.79	0.96	1.15
PM Emission Rate - g/h	4.05	1.61	0.81
CO Emissions Rate - g/h	89.6	107.8	98.0
Overall Efficiency - CSA B415.1-10			
% HHV Basis	71%	74%	75%
% LHV Basis	76%	79%	80%
Heat Output - Btu/h	52400	13300	16100
Category Weighting	20%	40%	40%

High Fire	Low Fire	Medium Fire
3.79	0.96	1.15
4.05	1.61	0.81
89.6	107.8	98.0
71%	74%	75%
76%	79%	80%
52400	13300	16100
20%	40%	40%

**ASTM E 3053 Weighted Averages**

PM Emission Rate - g/h	1.8
CO Emissions Rate - g/h (Arithmetic Average)	98.4
CO Emissions Rate - g/min (Arithmetic Average)	1.6
Overall Efficiency - CSA B415.1-10	
% HHV Basis	73%
% LHV Basis	79%
Heat Output Range - Btu/h	13300 to 52400

1.8
98.4
1.6
73%
79%
13300 to 52400

# WOODSTOVE PREBURN DATA

Client: New Buck Corporation

Model: 74

Run #: 3

Job #: 19-519

Tracking # 0042

Technician: AK

Date: 10/9/2019

Time (h)	Scale (lb)	Flue (F)	FB Avg. (F)
1	8.5	317	280
2	4.0	287	294
3	2.6	215	246
4	1.8	181	215
5	1.2	157	189
6	0.5	151	180
7	0.1	133	164
8	0.0	382	327
9	13.1	432	313
10	7.7	244	253
11	4.8	214	237
12	3.3	184	220
13	2.4	162	197
14	1.6	151	185
15	1.1	134	170
16	0.7	120	156
17	0.4	106	137
18	0.2	94	120
19	0.0	83	105
20	13.3	393	310
21	6.7	300	283
22	4.0	201	235
23	3.0	176	212
24	2.0	169	204
25	1.3	147	184
26	0.8	129	167
27	0.4	113	147
28	0.3	98	127
29	0.1	85	110
30	0.0	409	343
31	13.9	425	318
32	7.4	340	292
33	4.0	245	275
34	3.0	190	230
35	2.1	173	212
36	1.3	162	204
37	0.6	152	190
38	0.2	130	166

39	0.0	345	314
40	15.9	365	263
41	8.7	313	281
42	5.3	207	238
43	3.2	190	237
44	2.2	167	215
45	1.4	160	208
46	0.8	143	189
47	0.3	129	169
48	0.0	349	297
49	14.5	400	293
50	7.9	289	277







UNITED STATES ENVIRONMENTAL PROTECTION AGENCY  
RESEARCH TRIANGLE PARK, NC 27711

FEB 28 2018

Mr. Justin White  
Hearthstone QHPP, Inc.  
#17 Stafford Ave.  
Morrisville, VT 05661

OFFICE OF  
AIR QUALITY PLANNING  
AND STANDARDS

Dear Mr. White,

I am writing in response to your letter dated January 12, 2018, regarding wood heaters manufactured by Hearthstone QHPP, Inc. (Hearthstone). This response, dated February 28, 2018, supercedes our previous response (dated February 26, 2018) to correct an inaccuracy regarding required changes to ASTM E3053-17.

You are requesting to use an alternative test method, using cord wood, as referenced in section 60.532(c) of 40 CFR part 60, Subpart AAA, Standards of Performance for New Residential Wood Heaters (Subpart AAA) to meet the 2020 cord wood alternative compliance option. The 2020 cord wood alternative compliance option states that each affected wood heater manufactured or sold at retail for use in the United States on or after May 15, 2020, must not discharge into the atmosphere any gases that contain particulate matter in excess of 2.5 g/hr. Compliance must be determined by a cord wood test method approved by the Administrator along with the procedures in 40 CFR 60.534. You have requested approval to use the procedures and specifications found in ASTM Method E3053-17, a cord wood test method titled, "Standard Test Method for Determining Particulate Matter Emissions from Wood Heaters using Cordwood Test Fuel," in conjunction with ASTM E2515-11 and Canadian Standards Administration (CSA) Method CSA-B415.1-10, which are specified in 40 CFR 60.534.

We understand that Hearthstone is also requesting that the alternative method proposed above be approved to apply broadly to all wood heaters manufactured by Hearthstone meeting the requirements of Subpart AAA, from the approval date of this request until such time that Subpart AAA is revised or replaced to require a different cord wood certification method, providing all requirements of section 60.533 of Subpart AAA are met.

With the caveats set forth below, we approve your alternative test method request for certifying wood heaters using ASTM E3053-17 in conjunction with section 60.534 of Subpart AAA to meet the 2020 cord wood compliance option until such time that Subpart AAA is revised or replaced to require a different cord wood certification method. We also approve application of this alternative method to all wood heaters manufactured by Hearthstone meeting the requirements of Subpart AAA.

As required in Subpart AAA, section 60.354(d), you or your approved test laboratory must also measure the first hour of particulate matter emissions for each test run using a separate filter in one of the two parallel sampling trains. These results must be reported separately and also included in the total particulate matter emissions per run. Also, as required by Subpart AAA, section 60.534(e), you must have your approved laboratory measure the efficiency, heat output, and carbon monoxide emissions of the tested wood heater using CSA-B415.1-10. For measurement of particulate matter emission concentrations, ASTM 2515-11 must be used.

The following change to ASTM E3053-17 must be followed:

1. Coal bed conditions prior to loading test fuel. The coal bed shall be a level plane without valleys or ridges for all test runs in the high, low, and medium burn rate categories.

The following changes to ASTM E2515-11 must be followed:

1. The filter temperature must be maintained between 80 and 90 degrees F during testing.
2. Filters must be weighed in pairs to reduce weighing error propagation; see ASTM 2515-11, Section 10.2.1 Analytical Procedure.
3. Sample filters must be Pall TX-40 or equivalent Teflon-coated glass fiber, and of 47 mm, 90 mm, 100 mm, or 110 mm in diameter.
4. Only one point is allowed outside the +/- 10 percent proportionality range per test run.

A copy of this letter must be included in each certification test report where this alternative test method is utilized.

It is reasonable that this alternative test method approval be broadly applicable to all wood heaters subject to the requirements of 40 CFR part 60, Subpart AAA. For this reason, we will post this letter as ALT-125 on our website at <http://www3.epa.gov/ttn/emc/approalt.html> for use by other interested parties. As noted earlier in this letter, this alternative method approval is valid until such time that Subpart AAA is revised or replaced to require a different cord wood certification method, and at such time, this alternative will be reconsidered and possibly withdrawn.

If you have additional questions regarding this approval, please contact Michael Toney of my staff at 919-541-5247 or [toney.mike@epa.gov](mailto:toney.mike@epa.gov).

Sincerely,

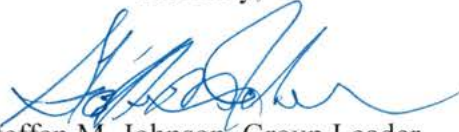

Steffan M. Johnson, Group Leader  
Measurement Technology Group

cc: Amanda Aldridge, EPA/OAQPS/OID  
Adam Baumgart-Getz, EPA/OAQPS/OID  
Rafael Sanchez, EPA/OECA  
Michael Toney, EPA/OAQPS/AQAD

## Sample Calculations – ASTM E3053 & E2515

Client: New Buck Corporation  
 Model: 74  
 Run: 1

Equations used to calculate the parameters listed below are described in this appendix. Sample calculations are provided for each equation. The raw data and printout results from a sample run are also provided for comparison to the sample calculations.

$M_{Fdb}$  – Weight of test fuel load, dry basis, lb (kg)

$M_{SUdb}$  – Weight of start-up fuel, dry basis, lb (kg)

$M_{Kdb}$  - Weight of kindling, dry basis, lb (kg)

$M_{FREHdb}$  - Total weight of all remaining fuel at end of high fire test run, lb (kg)

$M_{TFBHdb}$  - Total weight of all fuel burned during high fire test run, lb (kg), dry basis

$BR_H$  – Dry burn rate for high fire test run, from time when test fuel load is added to end of test run, lb/h (kg/h)

$M_{TFBdb}$  - Total weight of fuel burned during low or medium fire test run, lb (kg), dry basis

BR - Dry burn rate for low and medium fire test runs, lb/h (kg/h)

$V_s$  – Average gas velocity in the dilution tunnel, ft/sec

$Q_{sd}$  – Average gas flow rate in dilution tunnel, dscf/hr

$V_{m(std)}$  – Volume of gas sampled, corrected to dry standard conditions, dscf

$m_n$  – Total particulate matter collected, mg

$C_s$  - Concentration of particulate matter in tunnel gas, dry basis, corrected to STP, g/dscf

$E_T$  – Total particulate emissions, g

PR - Proportional rate variation

$PM_{RH}$  - Particulate emission rate for high fire test run, g/hr

$PM_{FH}$  - Particulate emission factor for high fire test run, g/dry kg of fuel burned

$PM_R$  – Particulate emission rate for low or medium fire test run, g/hr

$PM_F$  – Particulate emission factor for low or medium fire test run, g/dry kg of fuel burned

**M<sub>Fldb</sub> – Weight of test fuel load, dry basis, lb (kg)**

ASTM E3053 equation (1)

$$M_{Fldb} = \sum((M_{FLnwb})(100/(100 + MC_{FLn})))$$

Where,

- M<sub>FLnwb</sub> = Weight of each test fuel piece, n, in test fuel load per 8.4.1, wet basis, lb (kg)
- MC<sub>FLn</sub> = Average fuel moisture of test fuel piece, n, in test fuel load, % dry basis
- n = individual test fuel pieces that comprise the test fuel load, as applicable.

Sample Calculation:

n	M <sub>FLnwb</sub>	MC <sub>FLn</sub>	(M <sub>FLnwb</sub> )(100/(100 + MC <sub>FLn</sub> ))	
1	5.29	24.9	5.29 (100) / ( 100+ 24.9 )) =	4.23
2	3.53	24.4	3.53 (100) / ( 100+ 24.4 )) =	2.84
3	3.68	22.9	3.68 (100) / ( 100+ 22.9 )) =	3.00
4	5.00	26.5	5 (100) / ( 100+ 26.5 )) =	3.95
5	3.31	23.3	3.31 (100) / ( 100+ 23.3 )) =	2.68
6	0.00	NA	N/A	-
7	N/A	N/A	N/A	-
			SUM	16.70 lbs
M <sub>Fldb</sub> =	<b>16.70</b>	lbs		
M <sub>Fldb</sub> =	<b>7.58</b>	kg		

**$M_{SUdb}$  – Weight of start-up fuel, dry basis, lb (kg)**

ASTM E3053 equation (2)

$$M_{SUdb} = (M_{SUwb}) \left( \frac{100}{100 + MC_{SU}} \right)$$

Where,

$M_{SUwb}$  = Total weight of start-up fuel pieces, wet basis, lb (kg)

$MC_{SU}$  = Average fuel moisture of the piece(s) from which start-up fuel was split, % dry basis

Sample Calculation:

$$M_{SUwb} = 6.02$$

$$MC_{SU} = 23.2$$

$$M_{SUdb} = 6.0 \left( \frac{100}{100 + 23.2} \right)$$

$$M_{SUdb} = \mathbf{4.89} \text{ lbs}$$

$$= \mathbf{2.22} \text{ kg}$$

**$M_{Kdb}$  - Weight of kindling, dry basis, lb (kg)**

ASTM E3053 equation (3)

$$M_{Kdb} = (M_{Kwb}) \left( \frac{100}{100 + MC_K} \right)$$

Where,

$M_{Kwb}$  = Weight of kindling per 8.5.6, wet basis, lb (kg);

$MC_K$  = Average moisture of kindling (may be assumed 10%), % dry basis.

Sample calculation:

$$M_{Kwb} = 3.99$$

$$MC_K = 11.0$$

$$M_{Kdb} = 3.99 \left( \frac{100}{100 + 11.0} \right)$$

$$M_{Kdb} = \mathbf{3.59} \text{ lbs}$$

$$= \mathbf{1.63} \text{ kgs}$$

**$M_{FREHdb}$  - Total weight of all remaining fuel at end of high fire test run, lb (kg)**

ASTM E3053 equation (4)

$$M_{FREHdb} = M_{RSUBdb} + M_{FLEHdb}$$

Where,

$M_{RSUBdb}$  = Weight of residual start-up fuel bed when high fire test load added, lb (kg)

$M_{FLEHdb}$  = Weight of unburned portion of test fuel load at the end of the high fire test run, lb (kg)

Sample calculation:

$$M_{RSUBdb} = 2.3$$

$$M_{FLEHdb} = 2.1$$

$$M_{FREHdb} = 2.30 + 2.1$$

$$M_{FREHdb} = 4.40 \text{ lbs}$$

$$= 2.00 \text{ kg}$$

**$M_{TFBHdb}$  - Total weight of all fuel burned during high fire test run, lb (kg), dry basis**

ASTM E3053 equation (5)

$$M_{TFBHdb} = M_{Kdb} + M_{SUdb} + M_{FLdb} - M_{FREHdb}$$

Sample Calculation:

$$M_{Kdb} = 3.59$$

$$M_{SUdb} = 4.89$$

$$M_{FLdb} = 16.70$$

$$M_{FREHdb} = 4.40$$

$$M_{TFBHdb} = 3.59 + 4.89 + 16.70 - 4.40$$

$$= 20.78 \text{ lbs}$$

$$= 9.43 \text{ kg}$$



**BR<sub>H</sub> – Dry burn rate for high fire test run, from time when test fuel load is added to end of test run, lb/h (kg/h)**

ASTM E3053 equation (6)

$$BR_H = 60 (M_{FLdb} - M_{FLEHdb})/\theta_{H1}$$

Where,

$\theta_{H1}$  = Total duration of high fire test run, from time when test fuel load is added to end of test run, min.

Sample calculation:

$$\begin{aligned} M_{FLdb} &= 16.70 \\ M_{FLEHdb} &= 2.10 \\ \theta_{H1} &= 105 \end{aligned}$$

$$BR_H = \frac{60 ( 16.70 - 2.10 )}{105}$$

$$\begin{aligned} BR_H &= \mathbf{8.34} \text{ lb/hr} \\ &= \mathbf{3.79} \text{ kg/hr} \end{aligned}$$

**$M_{TFBdb}$  - Total weight of fuel burned during low or medium fire test run, lb (kg), dry basis**  
ASTM E3053 equation (7)

$$M_{TFBdb} = M_{FLdb} - M_{FREdb}$$

Where,

$M_{FLdb}$  = Total weight of fuel burned during low or medium fire test run, lb (kg), dry basis

$M_{FREdb}$  = Weight of remaining fuel at end of low or medium fire test run, lb (kg)

Sample Calculation:

$M_{FLdb}$  = N/A - Applicable to Low/Medium Fire Tests Only

$M_{FREdb}$  = N/A - Applicable to Low/Medium Fire Tests Only

$$\begin{aligned} M_{TFBdb} &= \text{N/A} - \text{N/A} \\ &= \text{N/A} \quad \text{lbs} \\ &= \text{N/A} \quad \text{kg} \end{aligned}$$

**BR - Dry burn rate for low and medium fire test runs, lb/h (kg/h)**

ASTM E3053 equation (8)

$$BR = \frac{60 M_{TFBdb}}{\theta}$$

Where,

$\theta$  = Total test run duration for low or medium fire test run, min.

Sample Calculation:

$M_{TFBdb}$  = N/A - Applicable to Low/Medium Fire Tests Only

$\theta$  = N/A - Applicable to Low/Medium Fire Tests Only

$$BR = \frac{60 \times N/A}{N/A}$$

BR = **N/A** lb/hr

= **N/A** kg/hr

**V<sub>s</sub> – Average gas velocity in the dilution tunnel, ft/sec**

ASTM E2515 equation (9)

$$V_s = F_p \times k_p \times C_p \times (\sqrt{\Delta P})_{avg} \times \sqrt{\frac{T_{s(avg)}}{P_s \times M_s}}$$

Where:

- F<sub>p</sub> = Adjustment factor for pitot tube center point reading =  $\frac{V_{strav}}{V_{scent}}$ , ASTM E2515 Equation (1)
- V<sub>scent</sub> = Dilution tunnel velocity calculated after the multi-point pitot traverse at the center, ft/sec
- V<sub>strav</sub> = Dilution tunnel velocity calculated after the multi-point pitot traverse, ft/sec
- k<sub>p</sub> = Pitot tube constant, 85.49
- C<sub>p</sub> = Pitot tube coefficient: 0.99, unitless
- ΔP\* = Velocity pressure in the dilution tunnel, in H<sub>2</sub>O
- T<sub>s</sub> = Absolute average gas temperature in the dilution tunnel, °R; (°R = °F + 460)
- P<sub>s</sub> = Absolute average gas static pressure in dilution tunnel, = P<sub>bar</sub> + P<sub>g</sub>, in Hg
- P<sub>bar</sub> = Barometric pressure at test site, in. Hg
- P<sub>g</sub> = Static pressure of tunnel, in. H<sub>2</sub>O; (in Hg = in H<sub>2</sub>O/13.6)
- M<sub>s</sub> = \*\*The dilution tunnel wet molecular weight; M<sub>s</sub> = 28.78 assuming a dry weight of 29 lb/lb-mole

Sample calculation:

$$F_p = \frac{18.69}{20.90} = 0.894$$

$$V_s = 0.894 \times 85.49 \times 0.99 \times 0.305 \times \left( \frac{129.8 + 460}{\left( 29.98 + \frac{-0.30}{13.6} \right) \times 28.78} \right)^{1/2}$$

$$V_s = \mathbf{19.11 \text{ ft/s}}$$

\*The ASTM test standard mistakenly has the square root of the average delta p instead of the average of the square root of delta p. The current EPA Method 2 is also incorrect. This was verified by Mike Toney at EPA.

\*\*The ASTM test standard mistakenly identifies M<sub>s</sub> as the dry molecular weight. It should be the wet molecular weight as indicated in EPA Method 2.

**Q<sub>sd</sub> – Average gas flow rate in dilution tunnel, dscf/hr**

ASTM E2515 equation (3)

$$Q_{sd} = 3600 \times (1 - B_{ws}) \times v_s \times A \times \frac{T_{std}}{T_{s(avg)}} \times \frac{P_s}{P_{std}}$$

Where:

- 3600 = Conversion from seconds to hours (ASTM method uses 60 to convert in minutes)
- B<sub>ws</sub> = Water vapor in gas stream, proportion by volume; assume 2%
- A = Cross sectional area of dilution tunnel, ft<sup>2</sup>
- T<sub>std</sub> = Standard absolute temperature, 528 °R
- P<sub>s</sub> = Absolute average gas static pressure in dilution tunnel, = P<sub>bar</sub> + P<sub>g</sub>, in Hg
- T<sub>s(avg)</sub> = Absolute average gas temperature in the dilution tunnel, °R; (°R = °F + 460)
- P<sub>std</sub> = Standard absolute pressure, 29.92 in Hg

Sample calculation:

$$Q_{sd} = 3600 \times (1 - 0.02) \times 19.11 \times 0.1963 \times \frac{528}{129.8 + 460} \times \frac{29.98 + \frac{-0.30}{13.6}}{29.92}$$

Q<sub>sd</sub> = **11865.8** dscf/hr

**$V_{m(std)}$  – Volume of Gas Sampled Corrected to Dry Standard Conditions, dscf**  
 ASTM E2515 equation (6)

$$V_{m(std)} = K_1 V_m Y \frac{P_{bar} + \frac{\Delta H}{13.6}}{T_m}$$

Where:

- $K_1$  = 17.64 °R/in. Hg
- $V_m$  = Volume of gas sample measured at the dry gas meter, dcf
- $Y$  = Dry gas meter calibration factor, dimensionless
- $P_{bar}$  = Barometric pressure at the testing site, in. Hg
- $\Delta H$  = Average pressure differential across the orifice meter, in. H<sub>2</sub>O
- $T_m$  = Absolute average dry gas meter temperature, °R

Sample Calculation:

Using equation for Train 1:

$$V_{m(std)} = 17.64 \times 19.859 \times 0.999 \times \frac{(29.98 + \frac{2.07}{13.6})}{(91.5 + 460)}$$

$V_{m(std)} = \mathbf{19.117}$  dscf

Using equation for Train 2:

$$V_{m(std)} = 17.64 \times 19.373 \times 0.996 \times \frac{(29.98 + \frac{2.01}{13.6})}{(88.2 + 460)}$$

$V_{m(std)} = \mathbf{18.704}$  dscf

Using equation for ambient train:

$$V_{m(std)} = 17.64 \times 0.00 \times 0 \times \frac{(29.98 + \frac{0.00}{13.6})}{(71.8 + 460)}$$

$V_{m(std)} = \mathbf{0}$  dscf

**$m_n$  – Total Particulate Matter Collected, mg**

ASTM E2515 Equation (12)

$$m_n = m_p + m_f + m_g$$

Where:

$m_p$  = mass of particulate matter from probe, mg

$m_f$  = mass of particulate matter from filters, mg

$m_g$  = mass of particulate matter from filter seals, mg

Sample Calculation:

Using equation for Train A (first hour):

$$m_n = 0.0 + 2.4 + 0.0$$

$$m_n = 2.4 \text{ mg}$$

Using equation for Train A (post-first hour):

$$m_n = 0.5 + 0.1 + 3.1$$

$$m_n = 3.7 \text{ mg}$$

Train A aggregate:

$$m_n = 2.4 + 3.7$$

$$m_n = \mathbf{6.1} \text{ mg}$$

Using equation for Train B:

$$m_n = 0.6 + 0.6 + 5.6$$

$$m_n = \mathbf{6.8} \text{ mg}$$

**C<sub>s</sub> - Concentration of particulate matter in tunnel gas, dry basis, corrected to STP, g/dscf**  
ASTM E2515 equation (13)

$$C_s = K_2 \times \frac{m_n}{V_{m(std)}}$$

Where:

- K<sub>2</sub> = Constant, 0.001 g/mg
- m<sub>n</sub> = Total mass of particulate matter collected in the sampling train, mg
- V<sub>m(std)</sub> = Volume of gas sampled corrected to dry standard conditions, dscf

Sample calculation:

For Train 1:

$$C_s = 0.001 \times \frac{6.1}{19.12}$$

$$C_s = \mathbf{0.00032} \text{ g/dscf}$$

For Train 2

$$C_s = 0.001 \times \frac{6.8}{18.70}$$

$$C_s = \mathbf{0.00036} \text{ g/dscf}$$

For Ambient Train

$$C_r = 0.001 \times \frac{\quad}{0}$$

$$C_r = \mathbf{0} \text{ g/dscf}$$



**$E_T$  – Total Particulate Emissions, g**

ASTM E2515 equation (15)

$$E_T = (c_s - c_r) \times Q_{std} \times \theta$$

Where:

- $C_s$  = Concentration of particulate matter in tunnel gas, g/dscf
- $C_r$  = Concentration particulate matter room air, g/dscf
- $Q_{std}$  = Average dilution tunnel gas flow rate, dscf/hr
- $\theta$  = Total time of test run, minutes

Sample calculation:

For Train 1

$$E_T = ( 0.000319 - 0 ) \times 11865.8 \times 137 /60$$

$$E_T = \mathbf{8.65} \text{ g}$$

For Train 2

$$E_T = ( 0.000364 - 0 ) \times 11865.8 \times 137 /60$$

$$E_T = \mathbf{9.85} \text{ g}$$

Average

$$E = \mathbf{9.25} \text{ g}$$

Total emission values shall not differ by more than 7.5% from the total average emissions

$$7.5\% \text{ of the average} = 0.69$$

$$\text{Train 1 difference} = 0.60$$

$$\text{Train 2 difference} = 0.60$$

**PR - Proportional Rate Variation**

ASTM E2515 equation (16)

$$PR = \left[ \frac{\theta \times V_{mi} \times V_s \times T_m \times T_{si}}{\theta_i \times V_m \times V_{si} \times T_{mi} \times T_s} \right] \times 100$$

Where:

- θ = Total sampling time, min
- θ<sub>i</sub> = Length of recording interval, min
- V<sub>mi</sub> = Volume of gas sample measured by the dry gas meter during the “ith” time interval, dcf
- V<sub>m</sub> = Volume of gas sample as measured by dry gas meter, dcf
- V<sub>si</sub> = Average gas velocity in the dilution tunnel during the "ith" time interval, ft/sec
- V<sub>s</sub> = Average gas velocity in the dilution tunnel, ft/sec
- T<sub>mi</sub> = Absolute average dry gas meter temperature during the "ith" time interval, °R
- T<sub>m</sub> = Absolute average dry gas meter temperature, °R
- T<sub>si</sub> = Absolute average gas temperature in the dilution tunnel during the "ith" time interval, °R
- T<sub>s</sub> = Absolute average gas temperature in the dilution tunnel, °R

Sample calculation (for the first 1 minute interval of Train 1):

$$PR = \left( \frac{137 \times 0.1406 \times 19.11 \times (84.0 + 460) \times (91.5 + 460)}{1 \times 19.859 \times 19.01 \times (129.8 + 460) \times (67.0 + 460)} \right) \times 100$$

PR = **94** %

**PM<sub>RH</sub> - Particulate emission rate for high fire test run, g/hr;**

ASTM E3053 equation (9)

$$PM_{RH} = 60(E_{TH}/\theta_{H2})$$

Where,

$E_{TH}$  = Total particulate emissions for high fire test run including kindling and start-up, g

$\theta_{H2}$  = Total duration of high fire test run, from ignition of kindling to end of test run, min.

Sample Calculation:

$$E_{TH} = 9.25$$

$$\theta_{H2} = 137$$

$$PM_{RH} = 60( 9.25 / 137 )$$

$$PM_{RH} = \mathbf{4.05} \text{ g/hr}$$

**PM<sub>FH</sub> - Particulate emission factor for high fire test run, g/dry kg of fuel burned.**

ASTM E3053 equation (10)

$$PM_{FH} = E_{TH}/M_{TFBHdb}$$

Sample Calculation:

$$E_{TH} = 9.25$$

$$M_{TFBHdb} = 9.43$$

$$PM_{FH} = 9.25 / 9.43$$

$$= \mathbf{0.98} \text{ g/kg}$$

**PM<sub>R</sub> - Particulate emission rate for low or medium fire test runs, g/hr**

ASTM E3053 equation (12)

$$PM_R = 60(E_T/\theta)$$

Where,

E<sub>T</sub> = Total particulate emissions for low or medium fire test runs from Test Method E2515, g

Sample Calculation:

E<sub>T</sub> = N/A - Applicable to Low/Medium Fire Tests Only

θ = N/A - Applicable to Low/Medium Fire Tests Only

$$PM_R = 60( N/A / N/A )$$

$$PM_{RH} = N/A \text{ g/hr}$$

**PM<sub>FH</sub> - Particulate emission factor for high fire test run, g/dry kg of fuel burned.**

ASTM E3053 equation (13)

$$PM_F = E_T/M_{TFBdb}$$

Sample Calculation:

E<sub>T</sub> = N/A - Applicable to Low/Medium Fire Tests Only

M<sub>TFBdb</sub> = N/A - Applicable to Low/Medium Fire Tests Only

$$PM_{FH} = N/A / N/A$$

$$= N/A \text{ g/kg}$$

## **New Buck 74 High Burn Procedure**

### **Kindling:**

Kindling weight in total should be 4.0lbs ( $\pm 0.5$ bs) seven pieces in total, 15-17" in length. Making sure the weight doesn't exceed what's allowed per the standard.

### **Start-up Fuel:**

The start-up fuel consists of six pieces, four of equal size and the remaining two are to be smaller just to elevate the fuel load. A total weight of 6.0lbs ( $\pm 0.5$ lbs) and a length of 15-17".

### **Test Fuel:**

The test fuel consists of five pieces with a nominal length of 16". Follow the fuel sheet guideline for specific weights of the core and remainder loads.

### **Start-up Procedure:**

The start-up fuel is comprised of six layers as follows, spreading small pieces of kindling throughout the layers.

Bottom: Two start-up pieces East/West

2<sup>nd</sup>: Two kindling pieces North/South

3<sup>rd</sup>: Three kindling pieces East/West

4<sup>th</sup>: Two start-up pieces with one kindling pieces in-between North/South

A small amount of kindling (0.3lbs) is to be placed between layers four and five.

5<sup>th</sup>: Two start-up pieces with one kindling pieces in-between East/West

Top: 0.5lbs of small kindling pieces stacked in the middle as shown in the picture below, (3-4 Layers).

### **Kindling and Start-up:**



Use a torch for 40 seconds to one minute to ignite the fuel, focusing the torch on the on the second layer pointing upward as seen in the picture blow. (all the smaller pieces). Keep the door open for one to two minutes.

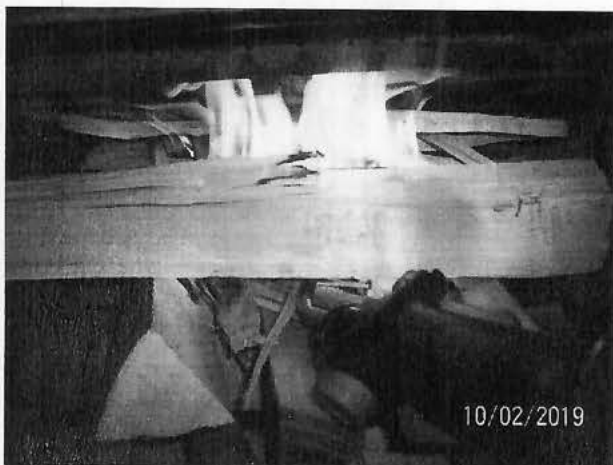

Set the fan control to the high position and it will turn on around 20-30 minutes.

The test load should be loaded at the bottom end of the allowable coal bed within 0.2lbs.

When loading, use one of the bottom test pieces to gently level the remaining fuel. Two bottom pieces in an East/West direction, placing the front piece directly in front of the pilot and the rear to the back off the wall. The remaining three go in a North/South direction on top. Be sure there are gaps between all fuel pieces for proper air flow. See test fuel picture for example. The door should be open  $\leq$  five minutes.

End the test at the high end of the allowable remaining weight.

**Test Fuel Load:**



## New Buck 74 Medium and Low Procedure

### Test Fuel:

Follow the guidelines of the cordwood standard (E3053-17) for correct moisture and weight ratios for the core and sub loads. There are five pieces in total. The nominal length is 16".

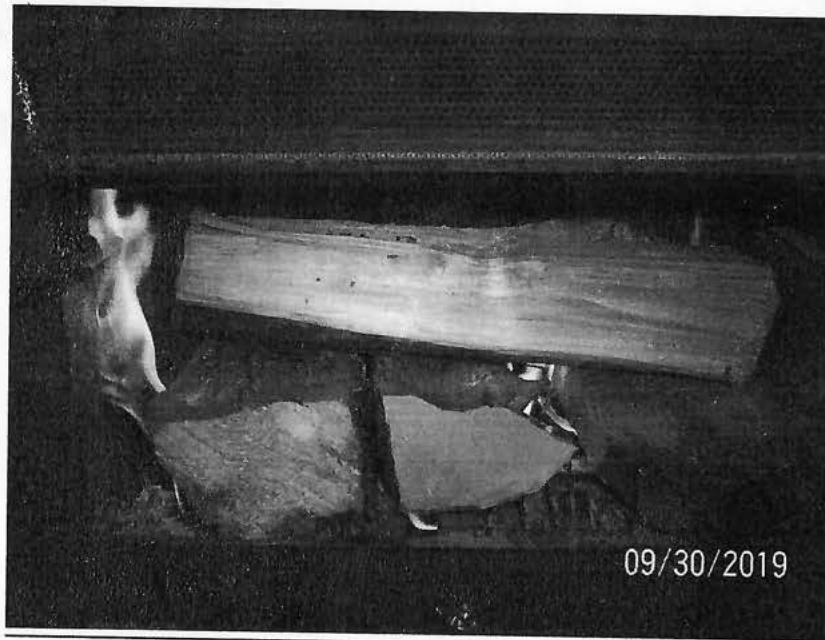



**Coal Bed:**

The coal bed will always result in running a high burn. There may be large pieces of fuel left after the high burn, as soon as the high burn has been complete, move the larger raw pieces toward the middle of the firebox stacked up for best combustion. Load the test fuel at the very low end of the coal bed within 0.2lbs. This allows more room to place the fuel.

**Fuel Loading & Settings:**

Level the coal bed before you start sampling. If there happens to be any raw pieces left over, place them to the far right. The Fan is turned on after the fuel is loaded and the door is shut and is set on low for the low burn, and medium burn. There should be gaps between all fuel pieces making sure there is plenty of space for air flow. Three pieces are to be placed on the bottom in a North/South direction. The remaining two pieces are to be placed in an East/West direction on top getting the front top piece just in front of the first tube and the rear piece just off the back wall. The door should be open less than two minutes. Keep the primary control open fully for 5-6 minutes then closing about half-way until the 15% is burned or the 15 minutes is up, whichever comes first. If you see the combustion getting noticeably dirtier, set the control at the desired setting.

The setting for the low is all the way closed.

The setting for the medium burn is 0.05" from the removable fan plate to the end of the air control.

**Moving Fuel Load:**

It may be necessary to move the fuel load at some point during the medium and low burns. Keep an eye on weight drop and stack draft to determine when to move the fuel if needed.

**WOOD STOVE TEST DATA PACKET  
ASTM E3053/E2515**



**Run 1 Data Summary**

Client: New Buck Corporation  
Model: 74  
Job #: 19-519  
Tracking #: 0042  
Test Date: 10/8/2019

  
\_\_\_\_\_  
Technician Signature

10/16/2019  
\_\_\_\_\_  
Date

# TEST RESULTS - ASTM E3053 / ASTM E2515

Client: New Buck Corporation  
 Model: 74  
 Run #: 1

Job #: 19-519  
 Tracking #: 0042  
 Technician: AK  
 Date: 10/8/2019

<b>Burn Rate (kg/hr):</b>	<b>3.79</b>
---------------------------	-------------

	Ambient Sample	Sample Train A	Sample Train B	1st Hour Filter
Total Sample Volume (ft <sup>3</sup> )	0.000	19.859	19.373	8.733
Average Gas Velocity in Dilution Tunnel (ft/sec)	19.11			
Average Gas Flow Rate in Dilution Tunnel (dscf/hr)	11865.8			
Average Gas Meter Temperature (°F)	71.8	91.5	88.2	78.2
Total Sample Volume (dscf)	0.000	19.117	18.704	8.613
Average Tunnel Temperature (°F)	129.8			
Total Time of Test (min)	137			
Total Particulate Catch (mg)	0.0	6.1	6.8	2.4
Particulate Concentration, dry-standard (g/dscf)	0.0000000	0.0003191	0.0003636	0.0002786
Total PM Emissions (g)	0.00	8.65	9.85	3.31
Particulate Emission Rate (g/hr)	0.00	3.79	4.31	3.31
Emissions Factor (g/kg)	-	0.92	1.04	-
Difference from Average Total Particulate Emissions (g)	-	0.60	0.60	-
Difference from Average Emissions Factor (g/kg)	-	0.06	0.06	-

Final Average Results	
Total Particulate Emissions (g)	9.25
Particulate Emission Rate (g/hr)	4.05
Emissions Factor (g/kg)	0.98
HHV Efficiency (%)	71.0%
LHV Efficiency (%)	76.0%
CO Emissions (g/min)	1.49

Quality Checks	Requirement	Observed	Result
Dual Train Precision	Each train within 7.5% of average emissions (in grams), or emission factors within 0.5 g/kg	See Above	OK
Filter Temps	>80 °F, <90 °F	Min: 83 / Max: 88	OK
Face Velocity	< 30 ft/min	8.8	OK
Leakage Rate	Less than 4% of average sample rate	0 cfm	OK
Ambient Temp	55-90 °F	Min: 66 / Max: 74	OK
Negative Probe Weight Evaluation	<5% of Total Catch	Probe Catch Not Negative	OK
Pro-Rate Variation	90% of readings between 90-110%; none greater than 120% or less than 80%	See Data Tabs	CHECK 10 MIN. INTERVAL PRO-RATES

# B415.1 Efficiency Results

**Manufacturer:** ⚡ Buck Corporation  
**Model:** 74  
**Date:** 10/08/19  
**Run:** 1  
**Control #:** 19-519  
**Test Duration:** 105  
**Output Category:** High

### Test Results in Accordance with CSA B415.1-09

	HHV Basis	LHV Basis
<b>Overall Efficiency</b>	71.0%	76.0%
<b>Combustion Efficiency</b>	98.7%	98.7%
<b>Heat Transfer Efficiency</b>	72.0%	77.0%

<b>Output Rate (kJ/h)</b>	55,208	52,371	<b>(Btu/h)</b>
<b>Burn Rate (kg/h)</b>	3.89	8.58	<b>(lb/h)</b>
<b>Input (kJ/h)</b>	77,716	73,722	<b>(Btu/h)</b>

<b>Test Load Weight (dry kg)</b>	6.81	15.02	<b>dry lb</b>
<b>MC wet (%)</b>	19.74		
<b>MC dry (%)</b>	24.59		
<b>Particulate (g )</b>	9.25		
<b>CO (g)</b>	157		
<b>Test Duration (h)</b>	1.75		

Emissions	Particulate	CO
<b>g/MJ Output</b>	0.10	1.62
<b>g/kg Dry Fuel</b>	1.36	23.01
<b>g/h</b>	5.28	89.59
<b>g/min</b>	0.09	1.49
<b>lb/MM Btu Output</b>	0.22	3.77

<b>Air/Fuel Ratio (A/F)</b>	11.21
-----------------------------	-------

**VERSION:** 2.2 **12/14/2009**

## HIGH FIRE FUEL LOAD DATA - ASTM E3053

Client: New Buck Corporation  
 Model: 74  
 Run #: 1

Job #: 19-519  
 Tracking # 0042  
 Technician: AK  
 Date: 10/8/2019

Nominal Loading Density (lbs/ft<sup>3</sup>, wet basis): 10  
 Usable Firebox Volume (ft<sup>3</sup>): 2.16  
 Target Load Weight (lbs): 21.60  
 Total Load Weight Range (lbs): 20.50 to 22.70  
 Core Load Weight Range (lbs): 9.70 to 14.00  
 Remainder Load Weight Range (lbs): 7.60 to 11.90  
 Core Load Piece Range (lbs): 3.20 to 5.40  
 Remainder Load Piece Range (lbs): 2.20 to 11.90  
 Max Allowable Kindling Weight (lbs): 4.16  
 Max Allowable Start-up Fuel Weight (lbs): 6.24

### CORE LOAD DATA

Piece #	Length (in)	Weight (lbs)	Within Spec?	Fuel Piece Moisture Readings (%DB)				Within Spec?	Dry Weight	
				1	2	3	Ave.		lbs	kg
1	16.00	5.29	In Range	22.8	24.2	27.8	24.9	In Range	4.23	1.92
2	16.00	3.53	In Range	25.6	25.3	22.3	24.4	In Range	2.84	1.29
3	16.00	3.68	In Range	18.6	26.4	23.6	22.9	In Range	3.00	1.36
Core Load Wt. (lbs)		12.50	In Range							

### REMAINDER LOAD DATA (1 to 3 Pieces)

Piece #	Length (in)	Weight (lbs)	Within Spec?	Fuel Piece Moisture Readings (%DB)				Within Spec?	Dry Weight	
				1	2	3	Ave.		lbs	kg
1	16.00	5.00	In Range	27.3	27.2	25.1	26.5	In Range	3.95	1.79
2	16.00	3.31	In Range	22.4	25.1	22.4	23.3	In Range	2.68	1.22
3			NA				NA	NA	NA	NA
Remainder Load (lbs)		8.31	In Range							

Total Load Weight (lbs): 20.81 In Range  
 Core Load % of Total Weight: 60% In Range 45-65%  
 Remainder % of Total Weight: 40% In Range 35-55%  
 Total Load % of Target Weight: 96% In Range 95-105%  
 Actual Fuel Loading Density (lb/ft<sup>3</sup>): 9.6  
 Total Load Average Moisture Content (%DB): 24.6 In Range 19-25%  
 Total Load Average Moisture Content (%WB): 19.7  
 Total Test Load Weight (dry basis): 16.70 lbs 7.58 kg

### KINDLING AND START-UP FUEL

Kindling Weight (lbs)	Within Spec?	Kindling Moisture Readings (%DB)				Within Spec?	Dry Weight	
		1	2	3	Avg.		lbs	kg
3.99	In Range	11.4	11.2	10.5	11.0	In Range	3.59	1.63

Start-up Fuel Wt. (lb)	Within Spec?	Start-up Moisture Readings (%DB)				Within Spec?	Dry Weight	
		1	2	3	Avg.		lbs	kg
6.02	In Range	22.5	24.9	22.1	23.2	In Range	4.89	2.22

### TEST FUEL LOADING RANGE

Allowable Residual Start-up Fuel Range (lb): 2.1 to 4.2  
 Actual Residual Start-up Fuel Weight (lb): 2.3 In Range

### TEST END POINT

High Fire Test Run End Point Range: 1.9 to 2.3 lb  
 Actual Fuel Load Ending Weight (lb): 2.1 In Range

Total Weight All Fuel Added: 30.82 lbs, wet basis      Total Weight All Fuel Burned (dry basis): 20.78 lbs  
 25.18 lbs, dry basis      9.43 kg  
 11.42 kg, dry basis

## DILUTION TUNNEL & MISC. DATA - ASTM E3053 / E2515

Client: **New Buck Corporation**  
 Model: **74**  
 Run #: **1**  
 Test Start Time: **10:14**  
 Test Type: **High Fire**

Job #: **19-519**  
 Tracking #: **0042**  
 Technician: **AK**  
 Date: **10/8/2019**

Recording Interval (min): **1**  
 Total Sampling Time (min): **137**  
 High Fire Test Load Time (min): **32**

Meter Box  $\gamma$  Factor: **0.999** (A)  
 Meter Box  $\gamma$  Factor: **0.996** (B)  
 Meter Box  $\gamma$  Factor:  (Ambient)

	Pre-Test	Post Test	Avg.
Barometric Pressure (in. Hg)	29.98	29.97	29.98
Relative Humidity (%)	52.6	43.6	
Room Air Velocity (ft/min)	0	0	
Scale Audit (lbs)	20.0	20.0	
Ambient Sample Volume:			ft <sup>3</sup>

Induced Draft Check (in. H<sub>2</sub>O): **0**  
 Smoke Capture Check (%): **100%**  
 Date Flue Pipe Last Cleaned: **10/7/2019**

**Sample Train Post-Test Leak Checks**

(A)		cfm @		in. Hg
(B)		cfm @		in. Hg
(Ambient)		cfm @		in. Hg

### DILUTION TUNNEL FLOW

**Traverse Data**

Point	dP (in H <sub>2</sub> O)	Temp (°F)
1	0.082	66
2	0.092	66
3	0.090	66
4	0.064	66
5	0.068	66
6	0.086	66
7	0.092	66
8	0.052	66
Center	0.100	66

Dilution Tunnel H<sub>2</sub>O: **2.00** percent  
 Tunnel Diameter: **6** inches  
 Pitot Tube Cp: **0.99** [unitless]  
 Dilution Tunnel MW(dry): **29.00** lb/lb-mole  
 Dilution Tunnel MW(wet): **28.78** lb/lb-mole  
 Tunnel Area: **0.1963** ft<sup>2</sup>

V<sub>strav</sub>: **18.69** ft/sec  
 V<sub>scnt</sub>: **20.90** ft/sec  
 F<sub>p</sub>: **0.894** [ratio]

Initial Tunnel Flow: **213.6** scf/min

Static Pressure: **-0.300** in. H<sub>2</sub>O

### TEST FUEL PROPERTIES

**ASTM 3053-17 - Table A1.1 Fuel Properties by Fuel Species**

Select Fuel Type	Species	%C	%H	%O	%Ash	MJ/kg	BTU/lb
	Ash, White	49.70	6.90	43.00	0.30	20.75	8927
	Beech	48.70	5.80	44.70	0.60	18.80	8088
	Birch, Sweet	49.80	6.50	43.40	0.30	20.12	8656
	Birch, Yellow	49.80	6.50	43.40	0.30	20.12	8656
	Doug Fir (Coast, Interior West/North)	48.73	6.87	43.90	0.50	19.81	8522
	Doug Fir (Interior South)	48.73	6.87	43.90	0.50	19.81	8522
	Elm, Rock	50.40	6.60	42.30	0.70	20.49	8815
	Elm, Soft	50.40	6.60	42.30	0.70	20.49	8815
	Gum, Red	50.88	6.06	41.57	1.28	19.72	8478
	Larch, Western	50.54	6.36	42.40	0.70	17.58	7558
X	Maple, Hard	50.64	6.02	41.74	1.35	19.96	8587
	Maple, Sugar	50.64	6.02	41.74	1.35	19.96	8587
	Oak, Red	49.50	6.62	43.70	0.20	20.20	8690
	Oak, White	50.40	6.59	42.70	0.20	20.50	8819
	Pine, Southern	52.60	7.00	40.10	1.31	22.30	9587
	Pine, Southern Long Leaf	52.60	7.02	40.10	1.30	22.30	9594

## WOODSTOVE PREBURN DATA

Client: New Buck Corporatio

Model: 74

Run #: 1

Job #: 19-519

Tracking #: 0042

Technician: AK

Date: 10/8/2019

**High Fire Test Begins from Cold Start, No Preburn is Performed**

# BOX A TEST DATA - ASTM E3053 / ASTM E2515

Client: New Buck CorporationJob #: 19-519Model: 74Tracking #: 0042Run #: 1Technician: AKDate: 10/8/2019

Elapsed Time (min)	Particulate Sampling Data							Fuel Weight (lb)		Temperature Data (°F)			
	Gas Meter (ft <sup>3</sup> )	Sample Rate (cfm)	Dilution Tunnel dP (in H <sub>2</sub> O)	Orifice dH (in H <sub>2</sub> O)	Meter Temp (°F)	Meter Vacuum (in Hg)	Pro. Rate (%)	Scale Reading	Weight Change	Dilution Tunnel	Flue	Filter	Ambient
0	0.000		0.905	0.01	67	-0.01		10.0		78	71	85	66
1	0.141	0.141	0.100	2.20	67	-2.68	94	9.9	-0.1	84	87	85	67
2	0.283	0.142	0.090	2.16	67	-0.62	103	9.7	-0.2	110	146	85	67
3	0.425	0.142	0.100	2.15	67	-0.47	97	9.3	-0.36	103	293	84	67
4	0.569	0.144	0.100	2.11	68	-0.22	99	9.0	-0.32	110	397	84	67
5	0.715	0.146	0.090	2.06	68	-0.18	105	8.7	-0.32	113	434	84	67
6	0.863	0.148	0.090	2.01	68	0	107	8.4	-0.3	116	460	84	67
7	1.010	0.147	0.090	2.02	68	-2.74	107	8.1	-0.3	120	482	83	67
8	1.159	0.149	0.090	1.97	68	-0.05	109	7.8	-0.3	122	494	83	68
9	1.308	0.149	0.090	1.98	69	-2.7	108	7.5	-0.3	122	495	83	68
10	1.455	0.147	0.090	2.03	69	-0.18	107	7.3	-0.2	122	492	83	68
11	1.603	0.148	0.090	2.01	69	-1.1	108	7.0	-0.3	124	499	83	68
12	1.747	0.144	0.090	2.11	70	-0.87	105	6.7	-0.3	126	503	83	68
13	1.892	0.145	0.090	2.08	70	-0.2	106	6.4	-0.3	129	524	83	68
14	2.037	0.145	0.090	2.07	70	-1.79	106	6.1	-0.3	128	516	83	68
15	2.184	0.146	0.090	2.05	71	-0.1	106	5.9	-0.2	126	508	83	69
16	2.327	0.144	0.090	2.12	71	-3.28	105	5.7	-0.2	127	503	83	69
17	2.474	0.147	0.090	2.03	72	-2.71	107	5.3	-0.36	131	520	83	70
18	2.620	0.146	0.090	2.05	72	-3.37	106	5.1	-0.24	130	529	83	70
19	2.766	0.146	0.090	2.05	72	-2.86	107	4.9	-0.2	131	530	83	70
20	2.913	0.146	0.090	2.05	73	-1.33	106	4.6	-0.3	132	530	83	70
21	3.059	0.146	0.090	2.06	73	-2.39	106	4.4	-0.2	132	531	83	70
22	3.205	0.146	0.090	2.05	74	-0.47	106	4.2	-0.2	132	532	83	70
23	3.351	0.147	0.090	2.04	74	-0.76	107	4.0	-0.22	132	535	83	70
24	3.499	0.147	0.090	2.02	75	-1.04	107	3.7	-0.28	133	532	83	70
25	3.646	0.147	0.090	2.02	75	-0.8	107	3.5	-0.22	134	537	83	71
26	3.794	0.148	0.090	1.99	76	-0.76	108	3.2	-0.26	133	544	83	71
27	3.943	0.148	0.090	1.99	76	-0.79	108	3.0	-0.22	135	550	83	71
28	4.088	0.145	0.090	2.09	77	-0.74	105	2.8	-0.2	134	552	83	71
29	4.233	0.145	0.090	2.07	77	-1.16	105	2.6	-0.2	132	542	83	71
30	4.378	0.145	0.090	2.09	78	-0.93	104	2.4	-0.2	130	525	83	71
31	4.523	0.145	0.090	2.09	78	-2.38	104	2.3	-0.1	127	505	83	72
32	4.665	0.143	0.080	2.14	79	-3.96	116	20.8	18.51	211	457	84	71



# BOX A TEST DATA - ASTM E3053 / ASTM E2515

Client: New Buck CorporationJob #: 19-519Model: 74Tracking #: 0042Run #: 1Technician: AKDate: 10/8/2019

Elapsed Time (min)	Particulate Sampling Data							Fuel Weight (lb)		Temperature Data (°F)			
	Gas Meter (ft <sup>3</sup> )	Sample Rate (cfm)	Dilution Tunnel dP (in H <sub>2</sub> O)	Orifice dH (in H <sub>2</sub> O)	Meter Temp (°F)	Meter Vacuum (in Hg)	Pro. Rate (%)	Scale Reading	Weight Change	Dilution Tunnel	Flue	Filter	Ambient
33	4.829	0.164	0.080	1.58	79	-4.79	133	20.5	-0.29	209	405	84	71
34	4.977	0.148	0.080	2.00	80	-0.28	120	20.3	-0.22	214	388	83	71
35	5.124	0.147	0.080	2.03	80	0	122	20.0	-0.34	247	413	85	71
36	5.266	0.142	0.090	2.16	81	-2.15	104	19.5	-0.46	154	491	85	71
37	5.409	0.143	0.090	2.13	81	-2.51	104	19.2	-0.3	148	538	85	71
38	5.555	0.145	0.090	2.07	82	-1.79	105	18.9	-0.3	144	560	85	72
39	5.703	0.148	0.090	2.01	82	0	107	18.6	-0.3	143	569	85	72
40	5.846	0.143	0.090	2.13	83	-2.15	103	18.3	-0.3	142	576	85	72
41	5.990	0.144	0.090	2.10	83	-2.97	104	18.0	-0.3	142	582	85	72
42	6.135	0.145	0.090	2.09	84	0	104	17.7	-0.3	142	587	85	72
43	6.279	0.144	0.090	2.11	84	-2.52	104	17.4	-0.3	142	587	86	72
44	6.423	0.144	0.090	2.12	85	-1.7	103	17.2	-0.24	142	587	86	72
45	6.567	0.145	0.090	2.09	85	-0.54	104	16.9	-0.26	143	588	86	72
46	6.712	0.145	0.090	2.08	86	-2.8	104	16.6	-0.3	143	585	86	72
47	6.856	0.144	0.090	2.12	86	-0.16	103	16.4	-0.22	142	585	86	72
48	7.001	0.145	0.090	2.09	87	-2.95	103	16.1	-0.28	141	583	86	73
49	7.145	0.144	0.090	2.10	87	-0.18	103	15.9	-0.2	141	581	86	72
50	7.289	0.144	0.090	2.12	88	0	102	15.6	-0.3	141	578	86	73
51	7.434	0.145	0.090	2.08	88	-1.52	103	15.4	-0.24	140	577	86	73
52	7.578	0.144	0.090	2.11	89	-2.78	103	15.1	-0.26	141	575	86	73
53	7.722	0.144	0.090	2.11	89	-0.53	102	14.9	-0.2	140	574	86	73
54	7.866	0.144	0.090	2.10	89	-0.05	103	14.6	-0.28	140	573	86	73
55	8.011	0.145	0.090	2.09	90	-3.03	103	14.4	-0.22	140	571	86	73
56	8.156	0.145	0.090	2.09	90	-0.48	103	14.2	-0.2	140	570	86	73
57	8.301	0.145	0.090	2.08	91	0	103	13.9	-0.3	139	571	86	73
58	8.444	0.144	0.090	2.12	91	-2.69	102	13.7	-0.2	139	571	86	73
59	8.588	0.144	0.090	2.11	92	-0.43	102	13.4	-0.28	140	571	86	73
60	8.733	0.145	0.090	2.09	92	0	102	13.2	-0.22	140	572	86	73
61	8.869	0.137	0.090	2.31	92	-0.68	97	12.9	-0.26	139	571	86	73
62	9.013	0.143	0.090	2.13	93	-0.84	101	12.7	-0.22	140	574	87	73
63	9.157	0.145	0.090	2.09	93	-0.51	102	12.5	-0.22	141	575	87	73
64	9.302	0.144	0.090	2.10	93	0	102	12.2	-0.3	140	576	87	73
65	9.446	0.144	0.090	2.11	94	-2.62	102	12.0	-0.2	140	574	87	74

# BOX A TEST DATA - ASTM E3053 / ASTM E2515

Client: New Buck CorporationJob #: 19-519Model: 74Tracking #: 0042Run #: 1Technician: AKDate: 10/8/2019

Elapsed Time (min)	Particulate Sampling Data							Fuel Weight (lb)		Temperature Data (°F)			
	Gas Meter (ft <sup>3</sup> )	Sample Rate (cfm)	Dilution Tunnel dP (in H <sub>2</sub> O)	Orifice dH (in H <sub>2</sub> O)	Meter Temp (°F)	Meter Vacuum (in Hg)	Pro. Rate (%)	Scale Reading	Weight Change	Dilution Tunnel	Flue	Filter	Ambient
66	9.591	0.145	0.090	2.09	94	-0.31	102	11.7	-0.3	140	573	87	73
67	9.735	0.144	0.090	2.11	95	0	101	11.5	-0.2	139	570	87	73
68	9.879	0.145	0.090	2.09	95	0	102	11.3	-0.2	138	567	87	74
69	10.024	0.145	0.090	2.09	95	-1.51	102	11.1	-0.2	138	565	87	74
70	10.168	0.144	0.090	2.12	96	-0.71	101	10.9	-0.2	137	563	87	74
71	10.312	0.145	0.090	2.09	96	-2.49	101	10.6	-0.3	137	559	87	74
72	10.457	0.145	0.090	2.09	96	-0.86	101	10.5	-0.14	137	557	87	74
73	10.602	0.145	0.090	2.09	97	-2.79	101	10.2	-0.26	136	554	87	74
74	10.746	0.144	0.090	2.11	97	0	101	10.0	-0.2	136	552	87	74
75	10.890	0.144	0.090	2.11	97	-1.3	101	9.8	-0.2	135	550	87	74
76	11.035	0.145	0.090	2.08	98	-2.71	101	9.6	-0.2	135	548	87	74
77	11.180	0.145	0.090	2.09	98	-2.7	101	9.3	-0.3	135	551	87	74
78	11.324	0.145	0.090	2.09	98	0	101	9.1	-0.2	135	553	88	74
79	11.470	0.145	0.090	2.07	98	-1.05	101	8.9	-0.2	135	551	88	74
80	11.616	0.146	0.090	2.06	99	0	101	8.7	-0.2	134	551	88	73
81	11.761	0.145	0.090	2.07	99	-1.33	101	8.5	-0.2	134	549	88	73
82	11.906	0.145	0.090	2.08	99	0	101	8.3	-0.2	134	547	88	73
83	12.052	0.146	0.090	2.06	100	-0.36	101	8.1	-0.2	134	544	88	73
84	12.197	0.145	0.090	2.07	100	0	101	7.9	-0.2	133	542	88	74
85	12.342	0.145	0.090	2.09	100	-0.18	100	7.7	-0.2	132	538	88	74
86	12.487	0.145	0.090	2.09	100	-2.44	100	7.5	-0.2	132	537	88	74
87	12.633	0.146	0.090	2.06	101	-0.35	101	7.4	-0.1	131	535	88	74
88	12.779	0.146	0.090	2.06	101	-2.68	101	7.2	-0.2	131	535	88	74
89	12.924	0.146	0.090	2.06	101	-2.49	101	7.0	-0.2	131	534	88	74
90	13.070	0.145	0.090	2.07	101	0	100	6.8	-0.2	130	534	88	74
91	13.215	0.145	0.090	2.08	102	-0.46	100	6.6	-0.2	130	532	88	73
92	13.361	0.146	0.090	2.06	102	-2.22	101	6.5	-0.1	130	532	88	73
93	13.506	0.145	0.090	2.07	102	-2.67	100	6.3	-0.2	131	535	88	73
94	13.654	0.147	0.090	2.02	102	-1.02	102	6.1	-0.2	130	535	88	73
95	13.801	0.147	0.090	2.03	102	-2.09	101	5.9	-0.2	129	530	87	73
96	13.946	0.145	0.090	2.07	103	-1.06	100	5.8	-0.1	128	522	87	73
97	14.091	0.145	0.090	2.09	103	0	99	5.7	-0.1	126	518	87	74
98	14.237	0.146	0.090	2.06	103	-2.18	100	5.5	-0.2	126	514	87	73

# BOX A TEST DATA - ASTM E3053 / ASTM E2515

Client: New Buck CorporationJob #: 19-519Model: 74Tracking #: 0042Run #: 1Technician: AKDate: 10/8/2019

Elapsed Time (min)	Particulate Sampling Data							Fuel Weight (lb)		Temperature Data (°F)			
	Gas Meter (ft <sup>3</sup> )	Sample Rate (cfm)	Dilution Tunnel dP (in H <sub>2</sub> O)	Orifice dH (in H <sub>2</sub> O)	Meter Temp (°F)	Meter Vacuum (in Hg)	Pro. Rate (%)	Scale Reading	Weight Change	Dilution Tunnel	Flue	Filter	Ambient
99	14.382	0.146	0.090	2.06	103	-2.54	100	5.4	-0.1	125	510	87	73
100	14.528	0.146	0.090	2.06	103	0	100	5.3	-0.1	123	507	87	72
101	14.673	0.145	0.090	2.08	104	-2.72	99	5.3	0	123	507	86	73
102	14.820	0.146	0.090	2.05	104	-0.47	100	5.1	-0.2	123	504	86	73
103	14.966	0.147	0.090	2.04	104	-0.01	100	5.0	-0.1	124	500	86	73
104	15.112	0.146	0.090	2.06	104	-1.66	99	4.9	-0.1	122	498	86	73
105	15.258	0.146	0.090	2.06	104	-0.58	99	4.8	-0.1	122	495	86	72
106	15.406	0.148	0.090	2.01	104	-2.45	101	4.7	-0.1	121	492	86	73
107	15.552	0.147	0.090	2.03	105	-0.02	100	4.5	-0.2	120	487	86	73
108	15.699	0.146	0.090	2.05	105	-2.28	99	4.4	-0.1	120	484	85	72
109	15.842	0.143	0.090	2.13	105	-0.13	97	4.3	-0.1	120	479	85	72
110	15.986	0.144	0.090	2.10	105	-2.53	98	4.2	-0.1	118	474	85	72
111	16.129	0.143	0.100	2.14	105	-1.64	92	4.1	-0.1	118	467	85	72
112	16.273	0.144	0.090	2.12	105	-2.54	97	4.0	-0.1	116	462	85	72
113	16.416	0.143	0.090	2.14	105	-2.19	97	3.9	-0.1	116	458	85	72
114	16.559	0.143	0.090	2.14	106	-2.61	97	3.8	-0.08	115	452	85	72
115	16.703	0.145	0.090	2.09	106	0	98	3.8	-0.06	115	446	84	72
116	16.847	0.144	0.090	2.12	106	-2.7	97	3.7	-0.06	115	440	84	72
117	16.990	0.143	0.090	2.13	106	-1.99	97	3.6	-0.1	114	435	84	72
118	17.134	0.144	0.090	2.12	106	-2.28	97	3.5	-0.1	113	430	84	72
119	17.277	0.144	0.090	2.12	106	-2.61	97	3.4	-0.06	112	424	84	72
120	17.422	0.145	0.100	2.08	106	0	93	3.4	-0.04	112	421	84	72
121	17.566	0.143	0.100	2.13	106	-0.37	91	3.3	-0.1	111	417	84	72
122	17.708	0.142	0.090	2.15	106	-2.12	96	3.3	0	111	413	84	72
123	17.853	0.145	0.100	2.09	106	-0.96	92	3.2	-0.1	111	408	84	72
124	17.997	0.144	0.090	2.12	106	-1.25	97	3.1	-0.1	110	406	84	72
125	18.140	0.144	0.090	2.12	107	0	96	3.1	0	109	403	84	72
126	18.283	0.143	0.090	2.13	107	-0.36	96	3.0	-0.1	109	400	84	72
127	18.426	0.143	0.090	2.14	107	0	96	2.9	-0.1	108	397	84	72
128	18.570	0.144	0.090	2.12	107	0	96	2.9	0	108	393	84	72
129	18.713	0.143	0.100	2.13	107	-2.6	91	2.8	-0.1	108	390	84	72
130	18.857	0.144	0.100	2.12	107	0	91	2.8	0	107	386	83	72
131	19.000	0.143	0.100	2.14	107	-0.41	91	2.7	-0.1	107	383	83	72

## BOX A TEST DATA - ASTM E3053 / ASTM E2515

Client: New Buck Corporation  
 Model: 74  
 Run #: 1

Job #: 19-519  
 Tracking #: 0042  
 Technician: AK  
 Date: 10/8/2019

Elapsed Time (min)	Particulate Sampling Data							Fuel Weight (lb)		Temperature Data (°F)			
	Gas Meter (ft <sup>3</sup> )	Sample Rate (cfm)	Dilution Tunnel dP (in H <sub>2</sub> O)	Orifice dH (in H <sub>2</sub> O)	Meter Temp (°F)	Meter Vacuum (in Hg)	Pro. Rate (%)	Scale Reading	Weight Change	Dilution Tunnel	Flue	Filter	Ambient
132	19.142	0.142	0.090	2.15	107	-2.68	95	2.7	0	107	380	83	72
133	19.286	0.144	0.090	2.12	107	-0.31	96	2.6	-0.1	106	377	83	72
134	19.429	0.143	0.090	2.13	107	-0.41	96	2.5	-0.1	106	375	83	73
135	19.572	0.143	0.090	2.13	107	0	96	2.4	-0.1	106	372	83	73
136	19.715	0.143	0.090	2.13	107	-2.36	96	2.2	-0.2	105	371	83	73
137	19.859	0.144	0.090	2.12	107	-1.46	96	2.1	-0.1	106	371	83	73
Avg/Tot	19.859	0.145	0.096	2.07	92	-1.26	102			130	498	85	71.8

## BOX B TEST DATA - ASTM E3053 / ASTM E2515

Client: New Buck CorporationJob #: 19-519Model: 74Tracking #: 0042Run #: 1Technician: AKDate: 10/8/2019

Elapsed Time (min)	Particulate Sampling Data							Flue Gas Data		
	Gas Meter (ft <sup>3</sup> )	Sample Rate (cfm)	Orifice dH (in H <sub>2</sub> O)	Meter Temp (°F)	Meter Vacuum (in Hg)	Pro. Rate (%)	Filter (°F)	Flue Draft (in H <sub>2</sub> O)	CO <sub>2</sub> (%)	CO (%)
0	0.000		0.00	67	-1		87	0.000	0.00	0.00
1	0.142	0.142	2.12	67	-0.17	97	86	0.020	0.39	0.10
2	0.284	0.142	2.08	67	-0.42	104	86	0.000	1.61	0.26
3	0.426	0.142	2.08	67	-1.42	98	85	0.110	11.28	0.87
4	0.567	0.141	2.04	67	-0.64	99	85	0.100	14.42	0.65
5	0.708	0.141	1.99	68	-0.51	104	85	0.050	13.44	0.68
6	0.849	0.141	1.93	68	-2.37	104	85	0.070	13.69	0.68
7	0.990	0.141	2.02	68	-0.21	105	85	0.090	13.44	0.87
8	1.131	0.141	1.99	68	-2.98	105	85	0.080	13.41	0.70
9	1.272	0.141	1.97	68	-0.55	105	85	0.060	13.21	0.74
10	1.414	0.141	2.00	69	-3.3	105	85	0.090	12.49	0.50
11	1.555	0.141	2.00	69	-2.84	105	85	0.110	12.44	0.62
12	1.696	0.142	2.06	69	-0.95	105	84	0.090	12.28	0.37
13	1.837	0.141	1.99	69	-3.42	105	84	0.100	14.01	0.19
14	1.979	0.141	1.99	70	-3.43	105	84	0.120	12.71	0.38
15	2.120	0.142	2.09	70	-0.89	105	84	0.030	11.30	0.50
16	2.262	0.142	2.07	70	-0.99	105	84	0.070	11.06	0.68
17	2.403	0.141	2.02	71	-2.81	105	84	0.060	12.09	0.49
18	2.545	0.141	2.04	71	-3.74	105	84	0.060	14.29	0.21
19	2.687	0.142	2.05	72	-1.16	105	84	0.090	13.40	0.04
20	2.828	0.142	2.08	72	-2.72	105	84	0.080	13.38	0.06
21	2.970	0.141	2.04	72	-1.23	105	84	0.080	13.31	0.07
22	3.111	0.141	2.03	73	-2.6	105	84	0.090	13.27	0.10
23	3.253	0.141	2.04	73	-1.07	105	84	0.060	13.59	0.12
24	3.394	0.141	2.04	74	-1.16	105	84	0.060	13.36	0.09
25	3.535	0.141	2.01	74	-1.26	105	84	0.070	13.43	0.05
26	3.677	0.141	2.01	75	-3.51	104	84	0.090	14.32	0.14
27	3.818	0.141	1.98	75	-3.29	104	84	0.070	13.93	0.08
28	3.960	0.142	2.13	76	-1.14	105	84	0.100	15.05	0.09
29	4.102	0.142	2.10	76	-2.89	105	84	0.100	13.85	0.00
30	4.244	0.142	2.09	76	-2.03	104	84	0.070	12.15	0.17
31	4.386	0.142	2.08	77	-3.51	104	84	0.080	10.80	0.23

# BOX B TEST DATA - ASTM E3053 / ASTM E2515

Client: New Buck Corporation  
 Model: 74  
 Run #: 1

Job #: 19-519  
 Tracking #: 0042  
 Technician: AK  
 Date: 10/8/2019

Elapsed Time (min)	Particulate Sampling Data							Flue Gas Data		
	Gas Meter (ft <sup>3</sup> )	Sample Rate (cfm)	Orifice dH (in H <sub>2</sub> O)	Meter Temp (°F)	Meter Vacuum (in Hg)	Pro. Rate (%)	Filter (°F)	Flue Draft (in H <sub>2</sub> O)	CO <sub>2</sub> (%)	CO (%)
32	4.528	0.142	2.17	77	-4.05	118	85	0.100	6.73	0.10
33	4.666	0.138	1.54	78	-4.93	114	85	0.060	2.40	0.11
34	4.796	0.130	0.55	78	-10.8	108	84	0.110	2.50	0.15
35	4.936	0.141	1.92	79	-2.51	120	85	0.100	2.77	0.13
36	5.078	0.142	2.10	79	-1.59	106	86	0.090	12.89	1.45
37	5.220	0.142	2.07	80	-2.44	105	86	0.080	14.41	1.28
38	5.362	0.142	2.05	80	-2.61	105	86	0.110	14.56	1.03
39	5.503	0.141	2.04	80	-2.82	105	86	0.100	13.90	0.97
40	5.645	0.142	2.05	81	-0.36	104	86	0.090	14.40	0.85
41	5.786	0.141	2.02	81	-2.9	104	86	0.070	14.03	0.61
42	5.927	0.141	2.02	82	-0.52	104	86	0.100	13.95	0.28
43	6.069	0.141	2.01	82	-0.57	104	86	0.120	13.75	0.30
44	6.210	0.141	2.02	83	-2.64	104	86	0.110	13.74	0.17
45	6.351	0.141	2.01	83	-2.73	104	86	0.070	13.59	0.24
46	6.492	0.141	1.99	83	-0.43	104	86	0.060	13.41	0.07
47	6.634	0.141	2.01	84	-2.92	104	86	0.090	13.18	0.18
48	6.775	0.141	2.00	84	-2.8	103	86	0.100	13.15	0.15
49	6.916	0.141	1.99	85	-0.92	103	86	0.100	12.82	0.16
50	7.057	0.141	2.00	85	-2.64	103	86	0.060	12.91	0.09
51	7.198	0.141	2.00	85	-0.43	103	86	0.060	12.78	0.14
52	7.339	0.141	2.00	86	-3.03	103	86	0.110	12.85	0.06
53	7.481	0.141	2.00	86	-1.07	103	86	0.070	12.64	0.14
54	7.622	0.141	2.00	86	-0.33	103	86	0.070	12.75	0.06
55	7.763	0.141	2.01	87	-2.85	103	86	0.070	12.99	0.09
56	7.905	0.142	2.06	87	-0.35	103	86	0.110	12.90	0.06
57	8.046	0.141	2.04	88	-2.93	103	86	0.110	13.08	0.01
58	8.188	0.142	2.06	88	-0.7	103	86	0.060	13.08	0.06
59	8.329	0.142	2.06	88	-0.28	103	86	0.110	13.10	0.08
60	8.471	0.142	2.06	89	-1.89	103	86	0.090	13.01	0.00
61	8.613	0.142	2.06	89	-1.45	103	86	0.060	13.13	0.10
62	8.754	0.142	2.05	89	-0.37	103	86	0.080	13.32	0.00
63	8.896	0.141	2.04	90	-2.94	102	86	0.090	13.82	0.00

# BOX B TEST DATA - ASTM E3053 / ASTM E2515

Client: New Buck Corporation  
 Model: 74  
 Run #: 1

Job #: 19-519  
 Tracking #: 0042  
 Technician: AK  
 Date: 10/8/2019

Elapsed Time (min)	Particulate Sampling Data							Flue Gas Data		
	Gas Meter (ft <sup>3</sup> )	Sample Rate (cfm)	Orifice dH (in H <sub>2</sub> O)	Meter Temp (°F)	Meter Vacuum (in Hg)	Pro. Rate (%)	Filter (°F)	Flue Draft (in H <sub>2</sub> O)	CO <sub>2</sub> (%)	CO (%)
64	9.037	0.142	2.05	90	-0.97	102	86	0.120	13.86	0.00
65	9.179	0.142	2.05	90	-0.3	102	86	0.110	13.59	0.00
66	9.321	0.142	2.05	91	-0.29	102	86	0.070	13.33	0.00
67	9.462	0.141	2.04	91	-0.69	102	86	0.050	13.37	0.00
68	9.604	0.142	2.05	91	-3.11	102	86	0.110	13.23	0.00
69	9.745	0.142	2.05	92	-1.46	102	86	0.100	13.44	0.00
70	9.887	0.141	2.04	92	-0.26	102	86	0.090	13.03	0.00
71	10.028	0.142	2.05	92	-2.96	102	87	0.090	13.02	0.00
72	10.170	0.142	2.05	92	-0.56	102	87	0.060	12.89	0.00
73	10.311	0.141	2.04	93	-1.69	101	87	0.070	12.72	0.00
74	10.453	0.142	2.07	93	-2.91	102	87	0.080	12.74	0.00
75	10.595	0.142	2.05	93	-1.14	101	87	0.080	12.84	0.00
76	10.736	0.142	2.05	93	-0.56	101	87	0.060	12.49	0.00
77	10.878	0.141	2.04	94	-0.53	101	87	0.070	12.56	0.00
78	11.019	0.142	2.07	94	-1.82	101	87	0.080	13.09	0.00
79	11.161	0.141	2.03	94	-1.81	101	87	0.100	12.84	0.00
80	11.302	0.142	2.06	94	-2.84	101	87	0.070	12.92	0.00
81	11.444	0.142	2.05	95	-2.67	101	87	0.060	12.55	0.00
82	11.585	0.142	2.05	95	-0.48	101	87	0.100	12.40	0.00
83	11.727	0.141	2.03	95	-1.15	101	87	0.110	12.10	0.00
84	11.868	0.141	2.04	95	-2.24	101	87	0.080	12.26	0.00
85	12.010	0.142	2.05	96	-2.51	101	87	0.080	11.81	0.00
86	12.152	0.142	2.06	96	-0.6	101	87	0.050	12.21	0.00
87	12.293	0.142	2.07	96	-1.48	101	87	0.080	12.07	0.00
88	12.435	0.142	2.05	96	-2.2	101	87	0.090	12.10	0.00
89	12.576	0.141	2.04	96	-1.08	101	87	0.100	12.32	0.00
90	12.718	0.141	2.04	97	-0.22	100	87	0.100	12.22	0.00
91	12.859	0.142	2.06	97	-2.83	100	86	0.090	12.29	0.00
92	13.001	0.142	2.05	97	-0.89	100	86	0.090	12.22	0.00
93	13.143	0.142	2.05	97	-1.5	100	86	0.120	12.25	0.00
94	13.284	0.142	2.05	97	-2.9	100	86	0.040	12.48	0.00
95	13.426	0.142	2.05	98	-1.23	100	86	0.110	12.10	0.00

## BOX B TEST DATA - ASTM E3053 / ASTM E2515

Client: New Buck CorporationJob #: 19-519Model: 74Tracking #: 0042Run #: 1Technician: AKDate: 10/8/2019

Elapsed Time (min)	Particulate Sampling Data							Flue Gas Data		
	Gas Meter (ft <sup>3</sup> )	Sample Rate (cfm)	Orifice dH (in H <sub>2</sub> O)	Meter Temp (°F)	Meter Vacuum (in Hg)	Pro. Rate (%)	Filter (°F)	Flue Draft (in H <sub>2</sub> O)	CO <sub>2</sub> (%)	CO (%)
96	13.567	0.142	2.06	98	-1.5	100	86	0.040	11.05	0.00
97	13.709	0.141	2.03	98	-2.78	100	86	0.100	10.70	0.00
98	13.850	0.142	2.05	98	-1.86	100	86	0.070	10.39	0.00
99	13.992	0.142	2.05	98	-3.09	100	86	0.070	10.44	0.00
100	14.133	0.141	2.04	98	-0.48	99	86	0.060	10.30	0.00
101	14.275	0.141	2.04	99	-0.32	99	86	0.060	10.01	0.00
102	14.416	0.141	2.04	99	-3.04	99	86	0.070	10.07	0.00
103	14.558	0.141	2.03	99	-0.82	99	85	0.040	10.22	0.00
104	14.700	0.142	2.08	99	-0.65	99	85	0.080	10.12	0.00
105	14.841	0.142	2.07	99	-0.51	99	85	0.110	9.74	0.00
106	14.983	0.142	2.06	99	-0.82	99	85	0.110	9.84	0.00
107	15.124	0.141	2.03	99	-0.44	99	85	0.050	9.86	0.04
108	15.266	0.141	2.01	100	-0.41	99	85	0.070	9.45	0.02
109	15.407	0.142	2.08	100	-0.34	99	85	0.070	9.25	0.06
110	15.549	0.142	2.05	100	-1.34	99	85	0.120	8.69	0.05
111	15.691	0.142	2.07	100	-1.37	94	85	0.060	8.51	0.16
112	15.832	0.141	2.02	100	-2.17	98	84	0.050	8.33	0.20
113	15.974	0.142	2.08	100	-0.84	99	84	0.120	8.11	0.18
114	16.115	0.142	2.06	100	-0.64	99	84	0.080	7.99	0.19
115	16.257	0.141	2.04	100	-2.66	98	84	0.060	7.65	0.19
116	16.399	0.142	2.07	100	-2.7	99	84	0.020	7.70	0.23
117	16.540	0.141	2.04	100	-2.13	98	84	0.050	7.40	0.29
118	16.682	0.142	2.06	100	-1.1	98	84	0.080	7.67	0.32
119	16.823	0.142	2.06	101	-2.62	98	84	0.080	7.41	0.38
120	16.965	0.141	2.04	101	-2.89	93	84	0.040	7.12	0.46
121	17.107	0.142	2.05	101	-0.19	93	84	0.070	7.36	0.34
122	17.248	0.142	2.05	101	-0.23	98	83	0.090	7.23	0.48
123	17.390	0.142	2.07	101	-2.44	93	83	0.090	7.20	0.46
124	17.532	0.142	2.08	101	-0.29	98	83	0.080	6.95	0.43
125	17.673	0.142	2.05	101	-1.25	98	83	0.020	7.23	0.44
126	17.815	0.142	2.06	101	-2.08	98	83	0.040	7.33	0.36
127	17.956	0.142	2.05	101	-0.18	98	83	0.090	6.89	0.39



## BOX B TEST DATA - ASTM E3053 / ASTM E2515

Client: New Buck Corporation  
 Model: 74  
 Run #: 1

Job #: 19-519  
 Tracking #: 0042  
 Technician: AK  
 Date: 10/8/2019

Elapsed Time (min)	Particulate Sampling Data							Flue Gas Data		
	Gas Meter (ft <sup>3</sup> )	Sample Rate (cfm)	Orifice dH (in H <sub>2</sub> O)	Meter Temp (°F)	Meter Vacuum (in Hg)	Pro. Rate (%)	Filter (°F)	Flue Draft (in H <sub>2</sub> O)	CO <sub>2</sub> (%)	CO (%)
128	18.098	0.142	2.06	101	-1.63	98	83	0.050	6.69	0.34
129	18.240	0.142	2.07	101	-0.64	93	83	0.060	6.30	0.46
130	18.381	0.142	2.07	101	-0.23	93	83	0.080	6.62	0.48
131	18.523	0.142	2.08	101	-0.38	93	83	0.010	6.40	0.51
132	18.665	0.142	2.05	101	-2.5	98	83	0.060	6.47	0.51
133	18.807	0.142	2.07	101	-2.6	98	83	0.140	6.69	0.61
134	18.948	0.142	2.05	101	-1.26	98	83	0.100	6.50	0.55
135	19.090	0.142	2.06	102	-2.74	97	83	0.080	6.51	0.49
136	19.231	0.142	2.06	102	-0.23	97	83	0.050	6.61	0.53
137	19.373	0.142	2.06	102	-2.13	97	83	0.040	6.90	0.41
Avg/Tot	19.373	0.141	2.01	88	-1.71	102	85	0.078	11.01	0.22

# WOODSTOVE SURFACE TEMPERATURE DATA

Client: New Buck Corporation  
 Model: 74  
 Run #: 1

Job #: 19-519  
 Tracking #: 0042  
 Technician: AK  
 Date: 10/8/2019

Elapsed Time (min)	Temperature Data (°F)						
	FB Left	FB Right	FB Back	FB Top	FB Bottom	Stove Surface Average	Catalyst Exit
0	64	64		66	64	64.5	N/A
1	64	64		66	64	64.5	N/A
2	67	66		66	64	65.8	N/A
3	72	73		67	64	69.0	N/A
4	80	82		69	64	73.8	N/A
5	90	92		73	64	79.8	N/A
6	101	102		78	64	86.3	N/A
7	115	114		85	64	94.5	N/A
8	130	127		92	64	103.3	N/A
9	145	141		100	65	112.8	N/A
10	160	154		109	65	122.0	N/A
11	172	168		118	65	130.8	N/A
12	185	182		127	65	139.8	N/A
13	198	196		137	65	149.0	N/A
14	211	208		147	65	157.8	N/A
15	222	218		157	66	165.8	N/A
16	234	227		163	67	172.8	N/A
17	244	238		169	68	179.8	N/A
18	255	249		176	69	187.3	N/A
19	264	260		184	70	194.5	N/A
20	275	271		191	72	202.3	N/A
21	283	281		198	73	208.8	N/A
22	293	291		205	75	216.0	N/A
23	303	302		211	77	223.3	N/A
24	313	312		217	79	230.3	N/A
25	321	322		223	81	236.8	N/A
26	330	332		230	82	243.5	N/A
27	341	342		236	84	250.8	N/A
28	351	351		242	86	257.5	N/A
29	361	361		249	88	264.8	N/A
30	371	369		255	90	271.3	N/A
31	379	376		258	92	276.3	N/A
32	386	383		265	93	281.8	N/A
33	389	385		269	93	284.0	N/A
34	394	385		271	94	286.0	N/A
35	397	384		270	94	286.3	N/A
36	399	383		267	97	286.5	N/A
37	400	384		266	99	287.3	N/A
38	402	384		267	101	288.5	N/A
39	400	385		271	104	290.0	N/A
40	400	385		277	107	292.3	N/A
41	402	386		283	109	295.0	N/A
42	402	388		290	111	297.8	N/A
43	403	389		297	113	300.5	N/A
44	403	391		305	115	303.5	N/A
45	405	392		312	116	306.3	N/A
46	409	394		318	118	309.8	N/A
47	411	395		324	119	312.3	N/A

# WOODSTOVE SURFACE TEMPERATURE DATA

Client: New Buck Corporation  
 Model: 74  
 Run #: 1

Job #: 19-519  
 Tracking #: 0042  
 Technician: AK  
 Date: 10/8/2019

Elapsed Time (min)	Temperature Data (°F)						
	FB Left	FB Right	FB Back	FB Top	FB Bottom	Stove Surface Average	Catalyst Exit
48	411	397		329	121	314.5	N/A
49	414	399		334	123	317.5	N/A
50	416	401		338	124	319.8	N/A
51	419	403		341	125	322.0	N/A
52	419	405		344	126	323.5	N/A
53	426	408		346	127	326.8	N/A
54	428	410		348	129	328.8	N/A
55	431	412		350	130	330.8	N/A
56	436	414		352	131	333.3	N/A
57	438	416		353	132	334.8	N/A
58	440	419		355	133	336.8	N/A
59	443	422		356	134	338.8	N/A
60	447	425		357	135	341.0	N/A
61	450	427		357	136	342.5	N/A
62	454	430		359	137	345.0	N/A
63	457	432		360	138	346.8	N/A
64	463	433		362	139	349.3	N/A
65	465	435		363	140	350.8	N/A
66	472	436		364	140	353.0	N/A
67	474	438		366	140	354.5	N/A
68	478	440		366	141	356.3	N/A
69	480	442		367	142	357.8	N/A
70	485	444		368	142	359.8	N/A
71	486	447		369	142	361.0	N/A
72	491	448		369	143	362.8	N/A
73	493	451		368	144	364.0	N/A
74	497	453		367	144	365.3	N/A
75	500	456		367	144	366.8	N/A
76	504	458		367	145	368.5	N/A
77	506	461		366	146	369.8	N/A
78	507	463		365	146	370.3	N/A
79	511	465		364	147	371.8	N/A
80	511	468		365	147	372.8	N/A
81	513	471		365	148	374.3	N/A
82	513	474		365	149	375.3	N/A
83	514	476		364	150	376.0	N/A
84	516	479		363	150	377.0	N/A
85	517	481		362	151	377.8	N/A
86	518	483		361	151	378.3	N/A
87	521	484		361	152	379.5	N/A
88	523	487		359	152	380.3	N/A
89	526	489		359	153	381.8	N/A
90	528	490		358	154	382.5	N/A
91	531	492		357	154	383.5	N/A
92	532	493		355	155	383.8	N/A
93	534	494		354	155	384.3	N/A
94	535	495		354	155	384.8	N/A
95	536	497		353	156	385.5	N/A

# WOODSTOVE SURFACE TEMPERATURE DATA

Client: New Buck Corporation  
 Model: 74  
 Run #: 1

Job #: 19-519  
 Tracking #: 0042  
 Technician: AK  
 Date: 10/8/2019

Elapsed Time (min)	Temperature Data (°F)						Catalyst Exit
	FB Left	FB Right	FB Back	FB Top	FB Bottom	Stove Surface Average	
96	537	499		352	156	386.0	N/A
97	540	501		351	157	387.3	N/A
98	540	501		349	156	386.5	N/A
99	540	503		348	156	386.8	N/A
100	538	504		346	156	386.0	N/A
101	538	504		346	156	386.0	N/A
102	540	506		344	157	386.8	N/A
103	539	506		341	158	386.0	N/A
104	538	507		339	158	385.5	N/A
105	536	508		337	158	384.8	N/A
106	536	509		335	158	384.5	N/A
107	537	510		332	159	384.5	N/A
108	536	510		330	159	383.8	N/A
109	537	511		327	159	383.5	N/A
110	537	512		325	160	383.5	N/A
111	536	511		322	159	382.0	N/A
112	535	512		319	160	381.5	N/A
113	533	512		316	160	380.3	N/A
114	530	511		312	161	378.5	N/A
115	530	511		310	161	378.0	N/A
116	528	511		306	162	376.8	N/A
117	527	511		303	162	375.8	N/A
118	525	510		300	162	374.3	N/A
119	524	510		297	162	373.3	N/A
120	518	509		294	162	370.8	N/A
121	519	508		291	162	370.0	N/A
122	516	506		287	162	367.8	N/A
123	516	505		284	163	367.0	N/A
124	513	503		281	163	365.0	N/A
125	511	501		279	163	363.5	N/A
126	510	500		275	163	362.0	N/A
127	507	499		273	164	360.8	N/A
128	506	497		270	164	359.3	N/A
129	503	496		267	165	357.8	N/A
130	503	493		264	165	356.3	N/A
131	502	491		262	165	355.0	N/A
132	499	488		259	165	352.8	N/A
133	496	485		256	164	350.3	N/A
134	495	483		254	165	349.3	N/A
135	493	480		252	165	347.5	N/A
136	495	478		250	166	347.3	N/A
137	492	475		247	165	344.8	N/A
Average	423	404	#DIV/0!	286	127	310	N/A

## LAB SAMPLE DATA - ASTM E2515

Client: New Buck Corporation  
 Model: 74  
 Run #: 1

Job #: 19-519  
 Tracking #: 0042  
 Technician: AK  
 Date: 10/8/2019

	Sample ID	Tare, mg	Total, mg	Final, mg	Catch, mg
<b>Train A Filters - First Hour</b>	T341	86.1	173.5	175.9	2.4
	T351	87.4			
<b>Train A Filters - Remainder</b>	T342	86.6	174.0	174.1	0.1
	T343	87.4			
<b>Train A Probe</b>	5A	116769.6	116769.6	116770.1	0.5
<b>Train A O-Rings</b>	5A	3535.9	3535.9	3539.0	3.1
<b>Train B Filters</b>	T344	88.4	263.5	264.1	0.6
	T345	87.8			
	T352	87.3			
<b>Train B Probe</b>	5B	116877.5	116877.5	116878.1	0.6
<b>Train B O-Rings</b>	5B	3531.9	3531.9	3537.5	5.6
<b>Background Filter</b>			0.0	0.0	

<b>Placed in Dessicator on:</b>	10/8/2019
---------------------------------	-----------

<b>Train A Filters - First Hour</b>	176.2	10/10 8:47	175.9	10/15 11:32	175.9	10/16 7:43	
<b>Train A Filters - Remainder</b>	174.2	10/10 8:46	174.1	10/15 11:32			
<b>Train A Probe</b>	116770.2	10/10 8:44	116770.1	10/15 11:25			
<b>Train A O-Rings</b>	3539.0	10/10 8:39	3539.0	10/15 11:22			
<b>Train B Filters</b>	264.3	10/10 8:47	264.0	10/15 11:32	264.1	10/16 7:44	
<b>Train B Probe</b>	116878.0	10/10 8:44	116878.1	10/15 11:25			
<b>Train B O-Rings</b>	3537.5	10/10 8:40	3537.5	10/15 11:22			
<b>Background Filter</b>							

1st hour Sub-Total, mg:	2.4
Remainder Sub-Total, mg:	3.7
<b>Train 1 Aggregate, mg:</b>	<b>6.1</b>
<b>Train 2 Aggregate, mg:</b>	<b>6.8</b>
Ambient Aggregate, mg:	0.0

## ASTM E3053 Wood Heater Run Sheets

Client: New Buck Corporation Job Number: 19-519 Tracking #: 0042  
 Model: 74 Run Number: 1 Test Date: 10/8/2019

### Wood Heater Run Notes

**Pre-Test Notes**

Pre-Test Start Time: N/A  
 Air Control Setting: N/A

Time	Notes
	N/A – Cold start test

**Test Notes**

Test Burn Start Time: 10:14  
 Air Control Setting: High

Time	Notes
0:00	Air & Fan set to high
0-1:00	Torch Ignition
2:05	Door Closed
31:00	Scale zeroed, test fuel loaded
33:00	Changed filter A for T351
34:00	Changed B for T352
60:00	Changed A for T342

Test Burn End Time: 12:31

### Flue Gas Concentration Measurement

**Calibration Gas Values:** Span Gas CO<sub>2</sub> (%): 15.53 CO (%): 4.084

**Calibration Results:**

	Pre Test		Post Test	
	Zero	Span	Zero	Span
Time	10:08	10:11	12:35	12:37
CO <sub>2</sub>	0.00	15.28	0.06	15.13
CO	0.000	3.971	-0.151	3.901

**Flue Gas Probe Leak Check:** Initial: No Leakage Final: No Leakage

Technician Signature: 

Date: 10/8/2019  
 Page 1 of 2

# ASTM E3053 Wood Heater Run Sheets

Client: New Buck Corporation  
Model: 74

Job Number: 19-519  
Run Number: 1

Tracking #: 0042  
Test Date: 10/8/2019

## Test Photos

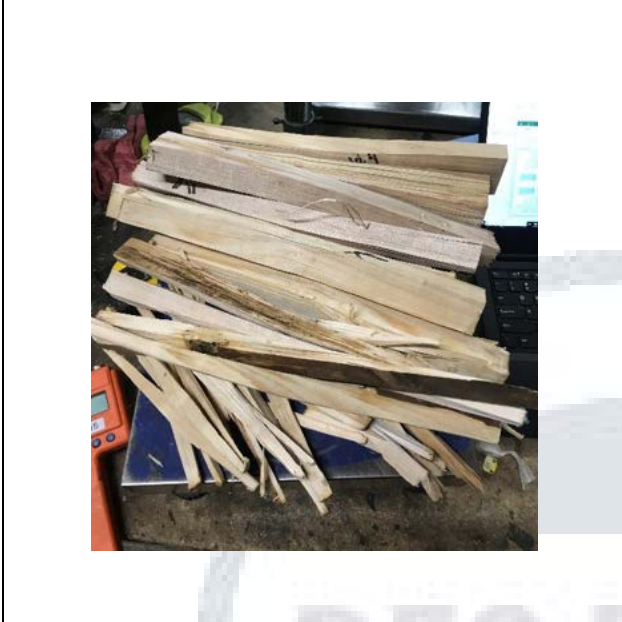

Kindling Fuel Load

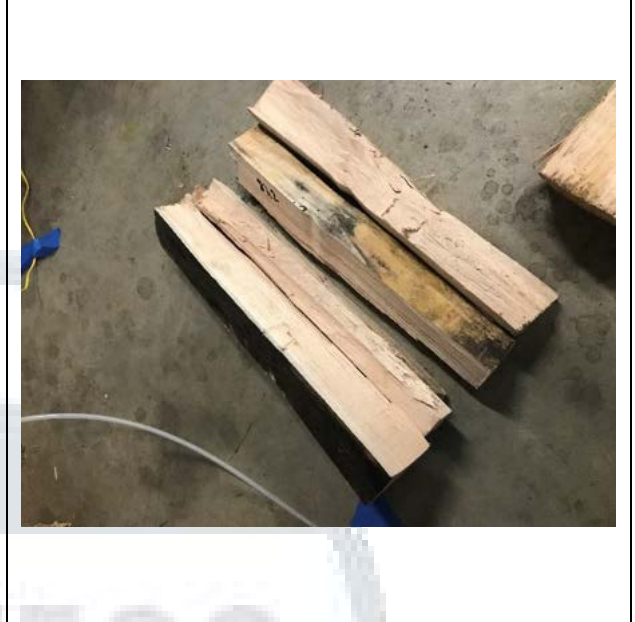

Start-up Fuel Load

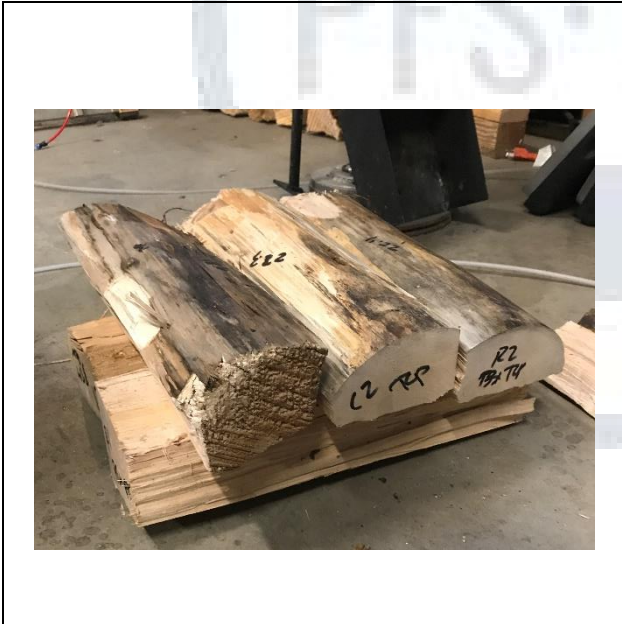

High Fire Fuel Load



Residual Start-up Fuel Coal Bed

Technician Signature: 

Date: 10/8/2019  
Page 2 of 2

**WOOD STOVE TEST DATA PACKET**  
**ASTM E3053/E2515**



**Run 2 Data Summary**

Client: New Buck Corporation  
Model: 74  
Job #: 19-519  
Tracking #: 0042  
Test Date: 10/8/2019

  
\_\_\_\_\_  
Technician Signature

10/16/2019  
\_\_\_\_\_  
Date



# TEST RESULTS - ASTM E3053 / ASTM E2515

Client: New Buck Corporation  
 Model: 74  
 Run #: 2

Job #: 19-519  
 Tracking #: 0042  
 Technician: AK  
 Date: 10/8/2019

<b>Burn Rate (kg/hr):</b>	<b>0.96</b>
---------------------------	-------------

	Ambient Sample	Sample Train A	Sample Train B	1st Hour Filter
Total Sample Volume (ft <sup>3</sup> )	0.000	84.117	82.999	8.700
Average Gas Velocity in Dilution Tunnel (ft/sec)	18.94			
Average Gas Flow Rate in Dilution Tunnel (dscf/hr)	12733.7			
Average Gas Meter Temperature (°F)	70.4	104.0	98.9	105.3
Total Sample Volume (dscf)	0.000	79.360	78.779	8.188
Average Tunnel Temperature (°F)	85.8			
Total Time of Test (min)	570			
Total Particulate Catch (mg)	0.0	10.1	9.9	4.4
Particulate Concentration, dry-standard (g/dscf)	0.0000000	0.0001273	0.0001257	0.0005374
Total PM Emissions (g)	0.00	15.40	15.20	6.84
Particulate Emission Rate (g/hr)	0.00	1.62	1.60	6.84
Emissions Factor (g/kg)	-	1.69	1.67	-
Difference from Average Total Particulate Emissions (g)	-	0.10	0.10	-
Difference from Average Emissions Factor (g/kg)	-	0.01	0.01	-

Final Average Results	
Total Particulate Emissions (g)	15.30
Particulate Emission Rate (g/hr)	1.61
Emissions Factor (g/kg)	1.68
HHV Efficiency (%)	73.6%
LHV Efficiency (%)	78.7%
CO Emissions (g/min)	1.80

Quality Checks	Requirement	Observed	Result
Dual Train Precision	Each train within 7.5% of average emissions (in grams), or emission factors within 0.5 g/kg	See Above	OK
Filter Temps	>80 °F, <90 °F	Min: 81 / Max: 90	OK
Face Velocity	< 30 ft/min	8.6	OK
Leakage Rate	Less than 4% of average sample rate	0 cfm	OK
Ambient Temp	55-90 °F	Min: 64 / Max: 78	OK
Negative Probe Weight Evaluation	<5% of Total Catch	Probe Catch Not Negative	OK
Pro-Rate Variation	90% of readings between 90-110%; none greater than 120% or less than 80%	See Data Tabs	CHECK 10 MIN. INTERVAL PRO-RATES

## B415.1 Efficiency Results

**Manufacturer:** ⚡ Buck Corporation  
**Model:** 74  
**Date:** 10/08/19  
**Run:** 2  
**Control #:** 19-519  
**Test Duration:** 570  
**Output Category:** Low

**Test Results in Accordance with CSA B415.1-09**

	HHV Basis	LHV Basis
<b>Overall Efficiency</b>	73.6%	78.7%
<b>Combustion Efficiency</b>	92.1%	92.1%
<b>Heat Transfer Efficiency</b>	79.9%	85.4%

<b>Output Rate (kJ/h)</b>	14,032	13,310	<b>(Btu/h)</b>
<b>Burn Rate (kg/h)</b>	0.96	2.11	<b>(lb/h)</b>
<b>Input (kJ/h)</b>	19,070	18,090	<b>(Btu/h)</b>

<b>Test Load Weight (dry kg)</b>	9.08	20.00	<b>dry lb</b>
<b>MC wet (%)</b>	19.56		
<b>MC dry (%)</b>	24.32		
<b>Particulate (g )</b>	15.30		
<b>CO (g)</b>	1,024		
<b>Test Duration (h)</b>	9.50		

Emissions	Particulate	CO
<b>g/MJ Output</b>	0.11	7.68
<b>g/kg Dry Fuel</b>	1.69	112.78
<b>g/h</b>	1.61	107.75
<b>g/min</b>	0.03	1.80
<b>lb/MM Btu Output</b>	0.27	17.85

<b>Air/Fuel Ratio (A/F)</b>	15.09
-----------------------------	-------

VERSION:

2.2

12/14/2009

## HIGH FIRE FUEL LOAD DATA - ASTM E3053

Client: New Buck Corporation  
 Model: 74  
 Run #: 2

Job #: 19-519  
 Tracking # 0042  
 Technician: AK  
 Date: 10/8/2019

Nominal Loading Density (lbs/ft<sup>3</sup>, wet basis): 10  
 Usable Firebox Volume (ft<sup>3</sup>): 2.16  
 Target Load Weight (lbs): 21.60  
 Total Load Weight Range (lbs): 20.50 to 22.70  
 Core Load Weight Range (lbs): 9.70 to 14.00  
 Remainder Load Weight Range (lbs): 7.60 to 11.90  
 Core Load Piece Range (lbs): 3.20 to 5.40  
 Remainder Load Piece Range (lbs): 2.20 to 11.90  
 Max Allowable Kindling Weight (lbs): 4.16  
 Max Allowable Start-up Fuel Weight (lbs): 6.24

### CORE LOAD DATA

Piece #	Length (in)	Weight (lbs)	Within Spec?	Fuel Piece Moisture Readings (%DB)				Within Spec?	Dry Weight	
				1	2	3	Ave.		lbs	kg
1	16.00	5.29	In Range	22.8	24.2	27.8	24.9	In Range	4.23	1.92
2	16.00	3.53	In Range	25.6	25.3	22.3	24.4	In Range	2.84	1.29
3	16.00	3.68	In Range	18.6	26.4	23.6	22.9	In Range	3.00	1.36
Core Load Wt. (lbs)		12.50	In Range							

### REMAINDER LOAD DATA (1 to 3 Pieces)

Piece #	Length (in)	Weight (lbs)	Within Spec?	Fuel Piece Moisture Readings (%DB)				Within Spec?	Dry Weight	
				1	2	3	Ave.		lbs	kg
1	16.00	5.00	In Range	27.3	27.2	25.1	26.5	In Range	3.95	1.79
2	16.00	3.31	In Range	22.4	25.1	22.4	23.3	In Range	2.68	1.22
3			NA				NA	NA	NA	NA
Remainder Load (lbs)		8.31	In Range							

Total Load Weight (lbs): 20.81 In Range  
 Core Load % of Total Weight: 60% In Range 45-65%  
 Remainder % of Total Weight: 40% In Range 35-55%  
 Total Load % of Target Weight: 96% In Range 95-105%  
 Actual Fuel Loading Density (lb/ft<sup>3</sup>): 9.6  
 Total Load Average Moisture Content (%DB): 24.6 In Range 19-25%  
 Total Load Average Moisture Content (%WB): 19.7  
 Total Test Load Weight (dry basis): 16.70 lbs 7.58 kg

### KINDLING AND START-UP FUEL

Kindling Weight (lbs)	Within Spec?	Kindling Moisture Readings (%DB)				Within Spec?	Dry Weight	
		1	2	3	Avg.		lbs	kg
3.99	In Range	11.4	11.2	10.5	11.0	In Range	3.59	1.63

Start-up Fuel Wt. (lb)	Within Spec?	Start-up Moisture Readings (%DB)				Within Spec?	Dry Weight	
		1	2	3	Avg.		lbs	kg
6.02	In Range	22.5	24.9	22.1	23.2	In Range	4.89	2.22

### TEST FUEL LOADING RANGE

Allowable Residual Start-up Fuel Range (lb): 2.1 to 4.2  
 Actual Residual Start-up Fuel Weight (lb): 2.3 In Range

# LOW & MEDIUM FIRE FUEL LOAD DATA - ASTM E3053

Client: New Buck Corporation  
 Model: 74  
 Run #: 2

Job #: 19-519  
 Tracking #: 0042  
 Technician: AK  
 Date: 10/8/2019

Nominal Loading Density (lbs/ft<sup>3</sup>, wet basis): 12  
 Usable Firebox Volume (ft<sup>3</sup>): 2.16  
 Target Load Weight (lbs): 25.92  
 Total Load Weight Range (lbs): 24.62 to 27.22  
 Core Load Weight Range (lbs): 11.66 to 16.85  
 Remainder Load Weight Range (lbs): 9.07 to 14.26  
 Core Load Piece Range (lbs): 3.89 to 6.48  
 Remainder Load Piece Range (lbs): 2.59 to 7.78

### CORE LOAD DATA

Piece #	Length (in)	Weight (lbs)	Within Spec?	Fuel Piece Moisture Readings (%DB)				Within Spec?	Dry Weight	
				1	2	3	Ave.		lbs	kg
1		5.22	In Range	26.2	27.2	28.0	27.1	In Range	4.11	1.86
2		4.23	In Range	21.0	19.7	18.9	19.9	In Range	3.53	1.60
3		5.64	In Range	24.2	22.6	27.6	24.8	In Range	4.52	2.05
Core Load Wt. (lbs)		15.09	In Range							

### REMAINDER LOAD DATA (2 to 3 Pieces)

Piece #	Length (in)	Weight (lbs)	Within Spec?	Fuel Piece Moisture Readings (%DB)				Within Spec?	Dry Weight	
				1	2	3	Ave.		lbs	kg
1		6.39	In Range	26.5	25.3	21.2	24.3	In Range	5.14	2.33
2		3.39	In Range	27.3	25.3	22.5	25.0	In Range	2.71	1.23
3			NA				NA	NA	NA	NA
Remainder Load (lbs)		9.78	In Range							

Remainder Load Small/Large Piece Weight Ratio: 53% In Range ≤ 67%  
 Total Load Weight (lbs): 24.87 In Range  
 Core Load % of Total Weight: 61% In Range 45-65%  
 Remainder % of Total Weight: 39% In Range 35-55%  
 Total Load % of Target Weight: 96% In Range 95-105%  
 Actual Fuel Loading Density (lb/ft<sup>3</sup>): 11.5  
 Total Load Average Moisture Content (%DB): 24.3 In Range 19-25%  
 Total Load Average Moisture Content (%WB): 19.6  
 Total Test Load Weight (dry basis): 20.00 lbs 9.07 kg

### TEST FUEL LOADING RANGE

Allowable Charcoal Bed Weight Range (lb): 2.54 to 4.9  
 Actual Charcoal Bed Wt. (lb): 2.7 In Range

### TEST END POINT

Actual Fuel Load Ending Weight (lb): 0.0 Valid Test (≥90%)

Total Fuel Burned During Test Run:  
 24.9 lbs, wet basis  
 20.0 lbs, dry basis  
 9.07 kg, dry basis

## DILUTION TUNNEL & MISC. DATA - ASTM E3053 / E2515

Client: **New Buck Corporation**  
 Model: **74**  
 Run #: **2**  
 Test Start Time: **12:51**  
 Test Type: **Low Fire**

Job #: **19-519**  
 Tracking #: **0042**  
 Technician: **AK**  
 Date: **10/8/2019**

Recording Interval (min): **1**  
 Total Sampling Time (min): **570**

Meter Box  $\gamma$  Factor: **0.999** (A)  
 Meter Box  $\gamma$  Factor: **0.996** (B)  
 Meter Box  $\gamma$  Factor:  (Ambient)

Induced Draft Check (in. H<sub>2</sub>O): **0**  
 Smoke Capture Check (%): **100%**  
 Date Flue Pipe Last Cleaned: **10/7/2019**

	Pre-Test	Post Test	Avg.
Barometric Pressure (in. Hg)	29.97	30.11	30.04
Relative Humidity (%)	41.8	46.3	
Room Air Velocity (ft/min)	0	0	
Scale Audit (lbs)	20.0	20.0	
Ambient Sample Volume:			ft <sup>3</sup>

### Sample Train Post-Test Leak Checks

(A)	0.000	cfm @	-9	in. Hg
(B)	0.000	cfm @	-10	in. Hg
(Ambient)		cfm @		in. Hg

## DILUTION TUNNEL FLOW

### Traverse Data

Point	dP (in H <sub>2</sub> O)	Temp (°F)
1	0.082	66
2	0.092	66
3	0.090	66
4	0.064	66
5	0.068	66
6	0.086	66
7	0.092	66
8	0.052	66
Center	0.100	66

Dilution Tunnel H<sub>2</sub>O: **2.00** percent  
 Tunnel Diameter: **6** inches  
 Pitot Tube Cp: **0.99** [unitless]  
 Dilution Tunnel MW(dry): **29.00** lb/lb-mole  
 Dilution Tunnel MW(wet): **28.78** lb/lb-mole  
 Tunnel Area: **0.1963** ft<sup>2</sup>

V<sub>strav</sub>: **18.69** ft/sec  
 V<sub>scent</sub>: **20.91** ft/sec  
 F<sub>p</sub>: **0.894** [ratio]

Initial Tunnel Flow: **213.9** scf/min

Static Pressure: **-0.300** in. H<sub>2</sub>O

## TEST FUEL PROPERTIES

**ASTM 3053-17 - Table A1.1 Fuel Properties by Fuel Species**

Select Fuel Type	Species	%C	%H	%O	%Ash	MJ/kg	BTU/lb
	Ash, White	49.70	6.90	43.00	0.30	20.75	8927
	Beech	48.70	5.80	44.70	0.60	18.80	8088
	Birch, Sweet	49.80	6.50	43.40	0.30	20.12	8656
	Birch, Yellow	49.80	6.50	43.40	0.30	20.12	8656
	Doug Fir (Coast, Interior West/North)	48.73	6.87	43.90	0.50	19.81	8522
	Doug Fir (Interior South)	48.73	6.87	43.90	0.50	19.81	8522
	Elm, Rock	50.40	6.60	42.30	0.70	20.49	8815
	Elm, Soft	50.40	6.60	42.30	0.70	20.49	8815
	Gum, Red	50.88	6.06	41.57	1.28	19.72	8478
	Larch, Western	50.54	6.36	42.40	0.70	17.58	7558
X	Maple, Hard	50.64	6.02	41.74	1.35	19.96	8587
	Maple, Sugar	50.64	6.02	41.74	1.35	19.96	8587
	Oak, Red	49.50	6.62	43.70	0.20	20.20	8690
	Oak, White	50.40	6.59	42.70	0.20	20.50	8819
	Pine, Southern	52.60	7.00	40.10	1.31	22.30	9587
	Pine, Southern Long Leaf	52.60	7.02	40.10	1.30	22.30	9594



## BOX A TEST DATA - ASTM E3053 / ASTM E2515

Client: New Buck CorporationJob #: 19-519Model: 74Tracking #: 0042Run #: 2Technician: AKDate: 10/8/2019

Elapsed Time (min)	Particulate Sampling Data							Fuel Weight (lb)		Temperature Data (°F)			
	Gas Meter (ft <sup>3</sup> )	Sample Rate (cfm)	Dilution Tunnel dP (in H <sub>2</sub> O)	Orifice dH (in H <sub>2</sub> O)	Meter Temp (°F)	Meter Vacuum (in Hg)	Pro. Rate (%)	Scale Reading	Weight Change	Dilution Tunnel	Flue	Filter	Ambient
0	0.000		0.090	0.03	105	-0.01		24.9		125	412	81	76
1	0.144	0.144	0.090	2.05	105	-0.18	109	24.7	-0.17	162	341	81	76
2	0.285	0.141	0.090	2.02	104	0	104	24.5	-0.2	125	346	81	76
3	0.433	0.148	0.090	2.10	104	-0.8	110	24.3	-0.2	129	398	81	76
4	0.582	0.149	0.090	2.11	104	-0.46	111	24.0	-0.3	135	472	82	76
5	0.728	0.146	0.090	2.07	104	-1.61	109	23.7	-0.3	140	539	83	76
6	0.871	0.144	0.090	2.05	104	-2.64	108	23.4	-0.32	146	583	84	77
7	1.022	0.151	0.090	2.13	104	-0.07	112	23.1	-0.28	138	569	85	76
8	1.178	0.155	0.090	2.18	104	-0.09	116	22.8	-0.3	137	562	85	77
9	1.331	0.154	0.090	2.16	104	-0.35	114	22.5	-0.3	139	563	86	77
10	1.480	0.148	0.090	2.10	104	-0.14	110	22.2	-0.3	139	572	86	77
11	1.610	0.130	0.090	1.90	104	-2.95	97	21.9	-0.3	140	574	86	76
12	1.752	0.142	0.090	2.03	104	-0.68	106	21.6	-0.3	141	575	87	77
13	1.912	0.160	0.090	2.23	104	-0.88	118	21.2	-0.4	131	562	87	77
14	2.065	0.154	0.090	2.16	104	-3.66	113	21.1	-0.1	124	514	87	77
15	2.210	0.145	0.090	2.06	104	-1.79	106	20.9	-0.2	120	473	87	76
16	2.334	0.124	0.090	1.83	104	-3.75	91	20.8	-0.14	118	444	87	76
17	2.437	0.103	0.090	1.59	104	-2.51	75	20.6	-0.2	115	421	87	76
18	2.550	0.113	0.090	1.71	104	-6.44	83	20.5	-0.06	114	404	87	77
19	2.699	0.149	0.090	2.11	104	-2.54	109	20.2	-0.28	113	395	87	77
20	2.845	0.146	0.090	2.07	104	-2.57	106	20.1	-0.12	112	390	88	76
21	2.991	0.146	0.090	2.08	104	-1.81	107	20.0	-0.1	111	387	88	77
22	3.139	0.147	0.090	2.09	104	-0.24	107	19.8	-0.2	111	385	88	77
23	3.284	0.146	0.090	2.07	104	-0.24	106	19.6	-0.18	111	386	87	77
24	3.430	0.146	0.100	2.07	105	-1.86	100	19.4	-0.2	110	388	87	77
25	3.578	0.148	0.090	2.10	105	0	108	19.3	-0.12	110	390	87	76
26	3.725	0.147	0.090	2.09	105	-2.33	107	19.1	-0.2	110	393	87	76
27	3.872	0.146	0.100	2.08	105	-2.49	101	18.9	-0.2	109	395	87	77
28	4.018	0.146	0.100	2.08	105	-0.39	101	18.8	-0.1	109	396	87	77
29	4.165	0.146	0.090	2.08	105	0	106	18.6	-0.2	108	397	87	76
30	4.313	0.148	0.090	2.10	105	-1.07	107	18.4	-0.2	109	398	86	75
31	4.459	0.146	0.090	2.08	105	-0.64	106	18.2	-0.2	108	397	86	76
32	4.606	0.146	0.100	2.08	105	-0.13	101	18.1	-0.1	107	396	86	75

## BOX A TEST DATA - ASTM E3053 / ASTM E2515

Client: New Buck CorporationJob #: 19-519Model: 74Tracking #: 0042Run #: 2Technician: AKDate: 10/8/2019

Elapsed Time (min)	Particulate Sampling Data							Fuel Weight (lb)		Temperature Data (°F)			
	Gas Meter (ft <sup>3</sup> )	Sample Rate (cfm)	Dilution Tunnel dP (in H <sub>2</sub> O)	Orifice dH (in H <sub>2</sub> O)	Meter Temp (°F)	Meter Vacuum (in Hg)	Pro. Rate (%)	Scale Reading	Weight Change	Dilution Tunnel	Flue	Filter	Ambient
33	4.754	0.148	0.090	2.10	105	-2.34	107	17.9	-0.2	106	393	86	75
34	4.902	0.148	0.100	2.10	106	0	102	17.8	-0.1	107	392	86	75
35	5.048	0.146	0.090	2.07	106	-2.17	105	17.6	-0.18	106	391	86	75
36	5.195	0.147	0.090	2.09	106	-0.7	106	17.4	-0.22	107	390	85	75
37	5.341	0.146	0.100	2.08	106	-0.01	100	17.3	-0.1	106	389	85	75
38	5.486	0.145	0.090	2.06	106	-2.12	105	17.1	-0.2	107	389	85	76
39	5.633	0.147	0.090	2.09	106	-2.34	106	17.0	-0.1	107	389	85	75
40	5.780	0.146	0.090	2.08	106	-2.62	106	16.8	-0.2	107	391	85	75
41	5.924	0.145	0.100	2.06	106	-0.95	99	16.6	-0.2	106	391	85	75
42	6.071	0.146	0.100	2.08	106	-2.4	100	16.5	-0.1	105	389	85	75
43	6.217	0.146	0.100	2.08	106	0	100	16.3	-0.2	105	389	85	75
44	6.365	0.147	0.100	2.09	106	0	101	16.2	-0.1	106	389	85	75
45	6.513	0.148	0.100	2.10	106	-1.09	101	16.0	-0.2	105	387	85	75
46	6.658	0.146	0.090	2.07	107	-0.32	105	15.9	-0.1	106	386	85	75
47	6.803	0.145	0.090	2.06	107	-0.53	104	15.7	-0.2	106	385	85	75
48	6.949	0.146	0.090	2.07	107	-1.97	105	15.6	-0.1	105	385	85	75
49	7.095	0.146	0.100	2.08	107	-0.21	100	15.4	-0.2	104	385	85	75
50	7.240	0.145	0.100	2.06	107	0	99	15.3	-0.12	104	383	85	75
51	7.383	0.143	0.100	2.04	107	0	97	15.1	-0.18	104	383	85	75
52	7.529	0.146	0.100	2.08	107	-2.71	100	15.0	-0.1	105	382	85	75
53	7.675	0.146	0.100	2.08	107	0	100	14.8	-0.2	103	382	85	75
54	7.823	0.147	0.100	2.09	107	-2.13	101	14.7	-0.1	104	380	85	75
55	7.970	0.147	0.100	2.09	107	-2.49	101	14.5	-0.2	104	379	85	75
56	8.116	0.146	0.100	2.08	107	-2.45	100	14.4	-0.1	103	377	85	75
57	8.259	0.143	0.100	2.04	107	-0.9	97	14.2	-0.2	104	374	85	75
58	8.408	0.149	0.100	2.11	107	-0.18	102	14.1	-0.1	103	372	85	75
59	8.554	0.146	0.100	2.07	107	-2.52	99	13.9	-0.2	104	370	85	75
60	8.700	0.146	0.100	2.08	107	-2.06	100	13.9	-0.04	103	369	85	75
61	8.850	0.150	0.100	2.12	107	0	102	13.7	-0.16	103	368	85	75
62	9.000	0.149	0.100	2.11	107	-0.63	102	13.5	-0.2	103	366	85	74
63	9.146	0.146	0.100	2.08	108	-2.71	100	13.4	-0.1	103	365	85	75
64	9.291	0.145	0.100	2.06	108	-2.46	98	13.2	-0.16	102	364	85	74
65	9.439	0.148	0.100	2.10	108	-2.61	101	13.1	-0.14	102	363	85	75



## BOX A TEST DATA - ASTM E3053 / ASTM E2515

Client: New Buck CorporationJob #: 19-519Model: 74Tracking #: 0042Run #: 2Technician: AKDate: 10/8/2019

Elapsed Time (min)	Particulate Sampling Data							Fuel Weight (lb)		Temperature Data (°F)			
	Gas Meter (ft <sup>3</sup> )	Sample Rate (cfm)	Dilution Tunnel dP (in H <sub>2</sub> O)	Orifice dH (in H <sub>2</sub> O)	Meter Temp (°F)	Meter Vacuum (in Hg)	Pro. Rate (%)	Scale Reading	Weight Change	Dilution Tunnel	Flue	Filter	Ambient
66	9.588	0.149	0.100	2.11	108	-2.53	101	13.1	0	102	363	85	74
67	9.736	0.148	0.100	2.10	108	0	101	12.9	-0.2	102	363	85	74
68	9.884	0.147	0.100	2.09	108	-1.89	100	12.8	-0.1	102	363	85	74
69	10.033	0.149	0.090	2.11	108	-2	107	12.7	-0.1	101	362	85	74
70	10.180	0.147	0.100	2.09	108	-0.25	100	12.5	-0.2	101	362	85	74
71	10.326	0.146	0.100	2.08	108	-2.69	99	12.4	-0.1	101	363	85	74
72	10.475	0.148	0.090	2.10	108	-2.31	106	12.2	-0.2	101	363	85	74
73	10.621	0.146	0.100	2.08	108	-0.14	100	12.1	-0.1	102	363	85	74
74	10.770	0.149	0.100	2.11	108	-2.52	101	12.0	-0.1	102	363	85	74
75	10.916	0.146	0.100	2.07	108	0	99	11.8	-0.2	102	364	85	74
76	11.062	0.146	0.100	2.08	108	-0.04	99	11.7	-0.12	101	364	85	74
77	11.212	0.150	0.100	2.12	108	-0.04	102	11.5	-0.18	101	364	85	74
78	11.360	0.148	0.100	2.10	108	-0.39	101	11.4	-0.1	102	364	85	74
79	11.509	0.148	0.100	2.10	108	-2.62	101	11.2	-0.2	101	365	85	74
80	11.656	0.147	0.100	2.09	108	-2.67	100	11.1	-0.1	101	366	85	74
81	11.808	0.152	0.100	2.14	108	0	103	10.9	-0.2	102	367	85	74
82	11.958	0.150	0.100	2.12	108	-0.12	102	10.8	-0.1	101	367	85	74
83	12.106	0.148	0.100	2.10	108	0	101	10.6	-0.2	102	368	85	74
84	12.251	0.145	0.100	2.06	108	-2.44	98	10.5	-0.1	102	369	85	74
85	12.398	0.147	0.100	2.09	108	-2.65	100	10.4	-0.1	102	369	85	74
86	12.547	0.149	0.090	2.11	108	-0.04	107	10.2	-0.16	102	371	85	74
87	12.694	0.147	0.100	2.09	108	0	100	10.1	-0.14	102	372	85	74
88	12.843	0.148	0.100	2.10	108	-2.26	101	10.0	-0.1	102	372	85	74
89	12.989	0.146	0.100	2.08	108	-0.81	99	9.8	-0.2	101	373	85	74
90	13.137	0.148	0.100	2.10	108	-1.91	101	9.7	-0.1	102	374	85	74
91	13.285	0.148	0.100	2.10	108	-1.48	101	9.6	-0.1	102	374	85	74
92	13.435	0.149	0.100	2.11	108	-2.49	101	9.5	-0.1	101	372	85	74
93	13.582	0.147	0.100	2.09	108	-0.84	100	9.4	-0.12	101	369	85	74
94	13.727	0.145	0.100	2.06	108	-0.17	98	9.3	-0.08	101	367	85	74
95	13.876	0.149	0.090	2.11	108	-1.25	107	9.1	-0.2	100	366	85	74
96	14.023	0.147	0.100	2.09	108	0	100	9.0	-0.14	100	364	85	74
97	14.167	0.144	0.100	2.05	108	0	98	8.9	-0.06	101	364	85	74
98	14.312	0.146	0.100	2.07	108	-2.2	99	8.8	-0.1	101	364	85	74

## BOX A TEST DATA - ASTM E3053 / ASTM E2515

Client: New Buck CorporationJob #: 19-519Model: 74Tracking #: 0042Run #: 2Technician: AKDate: 10/8/2019

Elapsed Time (min)	Particulate Sampling Data							Fuel Weight (lb)		Temperature Data (°F)			
	Gas Meter (ft <sup>3</sup> )	Sample Rate (cfm)	Dilution Tunnel dP (in H <sub>2</sub> O)	Orifice dH (in H <sub>2</sub> O)	Meter Temp (°F)	Meter Vacuum (in Hg)	Pro. Rate (%)	Scale Reading	Weight Change	Dilution Tunnel	Flue	Filter	Ambient
99	14.459	0.146	0.100	2.08	108	-2.59	99	8.6	-0.2	101	364	85	74
100	14.604	0.146	0.100	2.07	109	0	99	8.5	-0.1	100	363	85	74
101	14.751	0.146	0.100	2.08	109	-2.33	99	8.5	-0.04	100	362	85	74
102	14.897	0.146	0.100	2.08	109	-2.62	99	8.3	-0.16	100	362	85	74
103	15.044	0.146	0.100	2.08	109	-2.11	99	8.2	-0.1	100	361	85	74
104	15.189	0.146	0.090	2.07	109	-2.7	104	8.1	-0.1	100	361	85	74
105	15.336	0.146	0.100	2.08	109	-0.08	99	8.0	-0.1	100	359	85	74
106	15.481	0.146	0.100	2.07	109	0	99	7.9	-0.1	100	357	85	74
107	15.628	0.147	0.100	2.09	109	0	100	7.8	-0.1	99	353	85	74
108	15.773	0.145	0.100	2.06	109	-2.31	98	7.7	-0.1	99	350	85	74
109	15.920	0.147	0.100	2.09	109	-0.03	100	7.6	-0.08	98	348	85	74
110	16.068	0.147	0.100	2.09	109	-2.44	100	7.6	-0.02	99	345	85	74
111	16.216	0.148	0.100	2.10	109	-0.45	100	7.5	-0.1	99	343	85	74
112	16.362	0.146	0.100	2.08	109	-0.88	99	7.4	-0.1	99	342	85	74
113	16.509	0.146	0.100	2.08	109	0	99	7.3	-0.1	99	340	85	74
114	16.654	0.146	0.100	2.07	109	-0.09	98	7.2	-0.1	98	339	85	74
115	16.802	0.147	0.100	2.09	109	-0.21	100	7.1	-0.1	99	339	85	74
116	16.946	0.145	0.100	2.06	109	-1.77	98	7.0	-0.1	98	338	85	74
117	17.091	0.145	0.100	2.06	109	-1.49	98	6.9	-0.1	98	338	85	74
118	17.235	0.144	0.100	2.05	111	-0.42	97	6.8	-0.1	98	336	86	77
119	17.379	0.145	0.100	2.06	111	-2.39	97	6.8	0	98	334	86	78
120	17.522	0.143	0.100	2.04	109	0	97	6.7	-0.1	98	331	85	74
121	17.667	0.145	0.100	2.06	109	-2.5	98	6.6	-0.1	97	328	85	74
122	17.814	0.147	0.090	2.09	109	-0.27	105	6.6	0	97	325	85	74
123	17.959	0.145	0.100	2.06	109	-0.01	98	6.5	-0.1	97	322	85	74
124	18.104	0.145	0.100	2.06	109	-2.3	98	6.4	-0.1	96	320	85	74
125	18.250	0.146	0.090	2.08	109	-1.29	104	6.4	0	96	317	85	74
126	18.397	0.147	0.100	2.09	109	0	99	6.3	-0.1	96	315	85	73
127	18.543	0.146	0.100	2.07	109	0	98	6.2	-0.1	96	313	85	74
128	18.689	0.146	0.100	2.08	109	-2.59	99	6.2	0	95	311	85	74
129	18.837	0.147	0.100	2.09	109	0	99	6.1	-0.1	96	310	85	73
130	18.980	0.144	0.100	2.05	109	0	97	6.0	-0.1	95	308	85	73
131	19.125	0.145	0.100	2.06	109	-2.26	98	6.0	0	95	305	85	73

## BOX A TEST DATA - ASTM E3053 / ASTM E2515

Client: New Buck CorporationJob #: 19-519Model: 74Tracking #: 0042Run #: 2Technician: AKDate: 10/8/2019

Elapsed Time (min)	Particulate Sampling Data							Fuel Weight (lb)		Temperature Data (°F)			
	Gas Meter (ft <sup>3</sup> )	Sample Rate (cfm)	Dilution Tunnel dP (in H <sub>2</sub> O)	Orifice dH (in H <sub>2</sub> O)	Meter Temp (°F)	Meter Vacuum (in Hg)	Pro. Rate (%)	Scale Reading	Weight Change	Dilution Tunnel	Flue	Filter	Ambient
132	19.271	0.146	0.100	2.08	109	0	99	5.9	-0.1	94	301	84	73
133	19.417	0.146	0.100	2.07	109	-0.55	98	5.9	0	94	297	84	73
134	19.563	0.146	0.100	2.08	109	-1.91	99	5.8	-0.1	94	293	84	73
135	19.710	0.146	0.100	2.08	109	-2.33	99	5.8	0	93	290	84	73
136	19.854	0.144	0.100	2.05	109	0	97	5.7	-0.1	93	288	84	73
137	19.999	0.146	0.100	2.07	109	0	98	5.7	0	93	285	84	73
138	20.146	0.147	0.100	2.09	109	0	99	5.6	-0.1	92	282	85	73
139	20.294	0.147	0.100	2.09	109	-1.87	99	5.6	0	92	281	85	73
140	20.440	0.146	0.100	2.08	109	-1.8	99	5.5	-0.1	92	279	85	73
141	20.587	0.146	0.100	2.08	109	-2.07	98	5.5	-0.02	91	278	85	73
142	20.735	0.148	0.100	2.10	109	0	100	5.4	-0.08	91	277	84	73
143	20.880	0.146	0.090	2.07	109	-0.16	103	5.4	0	91	275	84	73
144	21.026	0.146	0.100	2.07	109	-2.46	98	5.3	-0.1	91	274	84	73
145	21.171	0.145	0.100	2.06	109	-2.52	97	5.3	0	91	272	84	72
146	21.317	0.146	0.100	2.08	109	-2.34	98	5.2	-0.1	90	271	84	72
147	21.464	0.146	0.100	2.08	109	-0.15	98	5.2	0	90	269	84	72
148	21.610	0.146	0.100	2.08	108	-0.09	99	5.1	-0.1	90	268	83	72
149	21.756	0.146	0.100	2.08	108	-0.06	99	5.1	0	90	266	83	72
150	21.900	0.144	0.100	2.05	108	-2.43	97	5.1	0	89	263	84	72
151	22.045	0.145	0.100	2.06	108	-2.14	97	5.0	-0.1	89	260	84	72
152	22.190	0.146	0.100	2.07	108	-2.43	98	5.0	0	89	258	84	72
153	22.337	0.146	0.100	2.08	108	-0.02	98	4.9	-0.1	89	255	84	72
154	22.485	0.148	0.100	2.10	108	-2.09	100	4.9	0	89	253	85	72
155	22.632	0.147	0.100	2.09	108	-2.71	99	4.9	0	89	251	85	72
156	22.781	0.149	0.100	2.11	108	0	100	4.8	-0.1	89	249	85	72
157	22.924	0.143	0.100	2.04	108	0	96	4.8	0	89	247	85	72
158	23.072	0.147	0.100	2.09	108	-1.75	99	4.7	-0.1	89	245	84	72
159	23.219	0.147	0.100	2.09	108	0	99	4.7	0	89	243	83	72
160	23.364	0.146	0.100	2.07	108	-0.42	98	4.7	0	88	241	83	72
161	23.511	0.146	0.100	2.08	108	-2.17	98	4.7	0	88	239	83	72
162	23.658	0.147	0.100	2.09	108	-2.06	99	4.6	-0.1	88	238	83	72
163	23.804	0.146	0.100	2.07	108	-2.48	98	4.6	0	88	236	84	72
164	23.948	0.145	0.100	2.06	108	-1.61	97	4.5	-0.1	87	235	84	72

## BOX A TEST DATA - ASTM E3053 / ASTM E2515

Client: New Buck CorporationJob #: 19-519Model: 74Tracking #: 0042Run #: 2Technician: AKDate: 10/8/2019

Elapsed Time (min)	Particulate Sampling Data							Fuel Weight (lb)		Temperature Data (°F)			
	Gas Meter (ft <sup>3</sup> )	Sample Rate (cfm)	Dilution Tunnel dP (in H <sub>2</sub> O)	Orifice dH (in H <sub>2</sub> O)	Meter Temp (°F)	Meter Vacuum (in Hg)	Pro. Rate (%)	Scale Reading	Weight Change	Dilution Tunnel	Flue	Filter	Ambient
165	24.096	0.147	0.100	2.09	108	-2.58	99	4.5	0	88	234	84	72
166	24.241	0.146	0.100	2.07	108	0	98	4.5	0	88	233	84	72
167	24.385	0.144	0.100	2.05	108	0	96	4.4	-0.1	87	231	84	72
168	24.531	0.146	0.100	2.07	108	0	98	4.4	0	87	230	84	72
169	24.674	0.144	0.100	2.05	108	-0.5	96	4.3	-0.1	87	228	84	72
170	24.821	0.146	0.100	2.08	108	-13.68	98	4.3	0	87	227	83	72
171	24.968	0.147	0.100	2.09	107	-13.92	99	4.3	0	87	227	83	72
172	25.113	0.145	0.100	2.06	107	-13.89	97	4.3	-0.04	87	226	83	73
173	25.257	0.145	0.100	2.06	107	-13.88	97	4.2	-0.06	87	224	83	73
174	25.402	0.145	0.100	2.06	107	-14	97	4.2	0	87	224	83	73
175	25.546	0.144	0.100	2.05	107	-13.92	97	4.2	-0.02	87	223	83	73
176	25.690	0.144	0.100	2.05	107	-14.02	97	4.1	-0.08	87	222	84	73
177	25.836	0.146	0.100	2.08	107	-13.98	98	4.1	0	87	221	84	73
178	25.982	0.146	0.100	2.08	107	-13.43	98	4.0	-0.1	87	221	84	73
179	26.125	0.143	0.100	2.04	107	-13.89	96	4.0	0	87	220	84	73
180	26.269	0.144	0.100	2.05	107	-14.06	97	4.0	0	86	220	84	73
181	26.411	0.142	0.100	2.03	107	-13.98	95	3.9	-0.1	86	220	83	73
182	26.556	0.145	0.100	2.06	107	-13.79	97	3.9	0	86	219	83	73
183	26.702	0.146	0.100	2.08	107	-13.87	98	3.9	0	87	220	83	73
184	26.848	0.146	0.100	2.07	107	-14.24	98	3.8	-0.1	87	219	83	73
185	26.991	0.144	0.100	2.05	107	-13.87	97	3.8	0	87	218	83	73
186	27.137	0.146	0.100	2.07	107	-13.87	98	3.8	0	87	218	83	73
187	27.285	0.148	0.100	2.10	107	-14.01	100	3.7	-0.1	87	218	83	73
188	27.430	0.145	0.100	2.06	107	-13.71	97	3.7	0	87	217	84	73
189	27.575	0.145	0.100	2.06	107	-13.97	97	3.6	-0.1	87	216	84	73
190	27.720	0.146	0.100	2.07	107	-14.11	98	3.6	0	87	216	84	73
191	27.864	0.144	0.100	2.05	107	0	97	3.6	0	87	215	84	73
192	28.007	0.143	0.100	2.04	107	-1.52	96	3.6	-0.02	87	214	84	73
193	28.153	0.146	0.100	2.08	107	-2.63	98	3.5	-0.08	87	213	84	73
194	28.297	0.144	0.100	2.05	107	0	97	3.5	0	86	212	84	73
195	28.439	0.142	0.100	2.03	107	-2.2	95	3.5	0	86	211	84	73
196	28.584	0.146	0.100	2.07	107	-0.36	98	3.5	0	86	210	84	73
197	28.727	0.143	0.100	2.04	107	0	96	3.5	0	85	208	84	73

# BOX A TEST DATA - ASTM E3053 / ASTM E2515

Client: New Buck CorporationJob #: 19-519Model: 74Tracking #: 0042Run #: 2Technician: AKDate: 10/8/2019

Elapsed Time (min)	Particulate Sampling Data							Fuel Weight (lb)		Temperature Data (°F)			
	Gas Meter (ft <sup>3</sup> )	Sample Rate (cfm)	Dilution Tunnel dP (in H <sub>2</sub> O)	Orifice dH (in H <sub>2</sub> O)	Meter Temp (°F)	Meter Vacuum (in Hg)	Pro. Rate (%)	Scale Reading	Weight Change	Dilution Tunnel	Flue	Filter	Ambient
198	28.871	0.144	0.100	2.05	107	-0.25	96	3.4	-0.1	85	208	84	72
199	29.017	0.146	0.100	2.08	107	0	98	3.4	0	86	207	84	72
200	29.160	0.143	0.100	2.04	107	-1.94	96	3.4	0	86	206	84	72
201	29.308	0.147	0.100	2.09	106	-0.12	99	3.3	-0.1	86	206	84	72
202	29.453	0.146	0.100	2.07	106	-2.71	98	3.3	0	86	205	84	72
203	29.597	0.144	0.100	2.05	106	-2.66	97	3.2	-0.06	86	204	84	72
204	29.741	0.144	0.100	2.05	106	-1.77	97	3.2	-0.04	86	204	84	72
205	29.887	0.146	0.100	2.08	106	-2.83	98	3.2	0	86	203	84	72
206	30.032	0.145	0.100	2.06	106	-1.35	97	3.1	-0.1	86	202	84	72
207	30.176	0.144	0.100	2.05	106	-2.48	97	3.1	0	86	202	83	72
208	30.318	0.142	0.100	2.03	106	-0.23	95	3.1	0	86	201	83	72
209	30.461	0.144	0.100	2.05	106	-2.74	97	3.1	0	86	201	83	72
210	30.607	0.146	0.100	2.07	106	0	98	3.1	0	86	200	83	72
211	30.751	0.144	0.100	2.05	106	0	97	3.0	-0.1	86	200	84	72
212	30.893	0.142	0.100	2.03	106	-0.99	95	3.0	0	86	199	84	72
213	31.035	0.142	0.100	2.03	106	-1.87	95	3.0	0	86	199	84	72
214	31.177	0.143	0.100	2.04	106	-0.46	96	3.0	0	86	198	84	72
215	31.330	0.153	0.100	2.15	106	-0.93	103	2.9	-0.1	86	197	84	72
216	31.475	0.145	0.100	2.06	106	0	97	2.9	0	86	197	84	72
217	31.622	0.147	0.100	2.09	106	-0.23	99	2.9	0	85	196	84	72
218	31.767	0.145	0.100	2.06	106	-0.74	97	2.9	0	86	195	83	72
219	31.910	0.144	0.100	2.05	106	0	97	2.9	0	86	194	83	72
220	32.057	0.146	0.100	2.08	106	0	98	2.9	0	85	193	83	72
221	32.202	0.145	0.100	2.06	106	-2.67	97	2.9	0	86	193	83	72
222	32.347	0.146	0.100	2.07	106	-1.56	98	2.9	0	85	192	83	72
223	32.491	0.144	0.100	2.05	106	-0.13	97	2.8	-0.1	85	191	84	72
224	32.637	0.146	0.100	2.08	106	-1.57	98	2.8	0	85	190	84	72
225	32.784	0.146	0.100	2.08	106	-0.78	98	2.8	0	85	190	84	72
226	32.932	0.148	0.100	2.10	106	-1.18	100	2.8	0	85	189	84	72
227	33.077	0.146	0.100	2.07	106	-2.52	98	2.8	0	84	189	83	72
228	33.220	0.143	0.100	2.04	106	0	96	2.8	0	85	188	83	72
229	33.366	0.146	0.100	2.07	106	-2.67	98	2.7	-0.06	84	188	83	72
230	33.513	0.147	0.100	2.09	106	0	99	2.8	0.06	84	188	83	72

## BOX A TEST DATA - ASTM E3053 / ASTM E2515

Client: New Buck CorporationJob #: 19-519Model: 74Tracking #: 0042Run #: 2Technician: AKDate: 10/8/2019

Elapsed Time (min)	Particulate Sampling Data							Fuel Weight (lb)		Temperature Data (°F)			
	Gas Meter (ft <sup>3</sup> )	Sample Rate (cfm)	Dilution Tunnel dP (in H <sub>2</sub> O)	Orifice dH (in H <sub>2</sub> O)	Meter Temp (°F)	Meter Vacuum (in Hg)	Pro. Rate (%)	Scale Reading	Weight Change	Dilution Tunnel	Flue	Filter	Ambient
231	33.660	0.146	0.100	2.08	106	-2.69	98	2.7	-0.1	84	187	83	72
232	33.806	0.146	0.100	2.08	106	-0.22	98	2.7	0	84	186	83	72
233	33.953	0.147	0.100	2.09	106	0	99	2.7	0	84	186	83	72
234	34.099	0.146	0.100	2.07	106	0	98	2.7	0	84	185	83	72
235	34.244	0.146	0.100	2.07	106	-2.81	98	2.7	0	84	185	84	72
236	34.393	0.148	0.100	2.10	106	0	100	2.7	0	84	184	83	72
237	34.537	0.145	0.100	2.06	106	-2.62	97	2.7	0	83	183	83	72
238	34.685	0.147	0.100	2.09	106	-0.13	99	2.7	0	83	182	83	72
239	34.833	0.148	0.100	2.10	106	-2.79	99	2.7	0	83	182	83	72
240	34.982	0.149	0.100	2.11	106	0	100	2.6	-0.1	83	181	83	72
241	35.128	0.146	0.100	2.07	106	-1.13	98	2.6	0	83	181	83	72
242	35.278	0.150	0.100	2.12	106	-0.47	101	2.6	0	83	180	83	72
243	35.423	0.146	0.100	2.07	106	-1.89	98	2.6	0	83	180	83	71
244	35.571	0.148	0.100	2.10	106	-2.7	99	2.6	0	83	179	83	71
245	35.719	0.147	0.100	2.09	106	0	99	2.6	0	83	178	83	71
246	35.868	0.149	0.100	2.11	106	-0.01	100	2.6	0	82	178	83	71
247	36.013	0.146	0.100	2.07	106	-2.36	98	2.6	0	83	178	83	71
248	36.160	0.146	0.100	2.08	106	-1.16	98	2.5	-0.06	83	177	83	71
249	36.303	0.143	0.100	2.04	106	0	96	2.5	-0.04	83	177	83	71
250	36.451	0.148	0.100	2.10	106	-1.33	99	2.5	0	83	176	83	71
251	36.597	0.146	0.110	2.08	106	0	94	2.5	0	83	176	83	71
252	36.743	0.146	0.100	2.07	106	-2.73	98	2.5	0	82	175	83	71
253	36.890	0.147	0.100	2.09	106	-2.4	99	2.4	-0.06	82	174	83	71
254	37.036	0.146	0.100	2.07	105	-2.59	98	2.5	0.06	82	174	83	71
255	37.184	0.148	0.100	2.10	105	-1.27	99	2.5	0	81	173	83	71
256	37.329	0.146	0.100	2.07	105	-0.07	98	2.4	-0.1	82	173	83	71
257	37.478	0.148	0.100	2.10	105	-2.72	99	2.4	0	81	172	83	71
258	37.624	0.146	0.100	2.08	105	-1.36	98	2.4	0	82	172	83	71
259	37.770	0.146	0.100	2.07	105	-2.06	98	2.4	0	81	171	83	71
260	37.917	0.147	0.100	2.09	105	-2.57	99	2.4	0	81	171	83	71
261	38.063	0.146	0.100	2.08	105	-0.94	98	2.4	0	81	170	83	71
262	38.213	0.149	0.100	2.11	105	-0.09	100	2.4	0	81	170	82	71
263	38.362	0.149	0.100	2.11	105	0	100	2.4	0	81	170	83	71

## BOX A TEST DATA - ASTM E3053 / ASTM E2515

Client: New Buck CorporationJob #: 19-519Model: 74Tracking #: 0042Run #: 2Technician: AKDate: 10/8/2019

Elapsed Time (min)	Particulate Sampling Data							Fuel Weight (lb)		Temperature Data (°F)			
	Gas Meter (ft <sup>3</sup> )	Sample Rate (cfm)	Dilution Tunnel dP (in H <sub>2</sub> O)	Orifice dH (in H <sub>2</sub> O)	Meter Temp (°F)	Meter Vacuum (in Hg)	Pro. Rate (%)	Scale Reading	Weight Change	Dilution Tunnel	Flue	Filter	Ambient
264	38.508	0.146	0.100	2.08	105	0	98	2.4	0	81	169	83	70
265	38.654	0.146	0.100	2.07	105	-2.57	98	2.3	-0.1	81	169	83	70
266	38.803	0.149	0.100	2.11	105	-2.72	100	2.3	0	81	169	83	71
267	38.950	0.147	0.100	2.09	105	-2.78	99	2.3	0	81	169	83	70
268	39.098	0.148	0.100	2.10	105	0	99	2.3	0	81	168	83	71
269	39.246	0.147	0.100	2.09	105	-2.23	99	2.3	0	81	168	83	70
270	39.393	0.147	0.100	2.09	105	-1.37	99	2.3	0	80	168	83	71
271	39.540	0.147	0.100	2.09	105	-2.73	99	2.3	0	80	167	82	71
272	39.687	0.146	0.100	2.08	105	-1.22	98	2.3	0	80	167	82	70
273	39.832	0.146	0.100	2.07	105	-0.32	98	2.3	0	80	167	82	71
274	39.979	0.146	0.100	2.08	105	-1.48	98	2.2	-0.1	81	167	82	70
275	40.125	0.146	0.100	2.08	105	-1.17	98	2.3	0.1	80	166	83	70
276	40.272	0.147	0.100	2.09	105	0	99	2.2	-0.1	80	166	83	70
277	40.419	0.146	0.100	2.08	105	-2.51	98	2.2	0	80	166	83	70
278	40.564	0.146	0.100	2.07	105	-1.63	98	2.2	0	80	165	83	70
279	40.714	0.149	0.100	2.11	105	-2.69	100	2.2	0	80	165	83	70
280	40.860	0.146	0.100	2.08	105	-2.64	98	2.2	0	80	165	82	70
281	41.008	0.148	0.100	2.10	105	0	99	2.2	0	80	165	82	70
282	41.156	0.148	0.100	2.10	105	0	99	2.1	-0.1	80	164	82	70
283	41.304	0.147	0.100	2.09	105	-2.05	99	2.1	0	80	163	82	70
284	41.452	0.148	0.100	2.10	105	-1	99	2.1	0	80	163	82	70
285	41.601	0.149	0.100	2.11	105	-1.11	100	2.1	0	80	162	83	70
286	41.749	0.148	0.100	2.10	105	0	99	2.1	0	79	162	83	70
287	41.897	0.147	0.100	2.09	105	0	99	2.1	0	79	162	83	70
288	42.045	0.148	0.100	2.10	104	-1.65	99	2.1	0	80	162	82	70
289	42.193	0.148	0.100	2.10	104	-0.51	99	2.1	0	79	162	82	70
290	42.342	0.149	0.100	2.11	104	-0.47	100	2.1	-0.04	79	161	82	70
291	42.492	0.150	0.100	2.12	104	-2.54	101	2.1	0.04	80	161	82	70
292	42.639	0.147	0.100	2.09	104	0	99	2.0	-0.1	79	161	82	70
293	42.788	0.148	0.100	2.10	104	0	99	2.0	0	79	161	82	70
294	42.935	0.147	0.100	2.09	104	-2.66	99	2.0	0	79	161	82	69
295	43.085	0.150	0.100	2.12	104	-0.25	101	2.0	0	79	160	82	69
296	43.231	0.146	0.100	2.08	104	0	98	2.0	0	79	160	82	70

## BOX A TEST DATA - ASTM E3053 / ASTM E2515

Client: New Buck CorporationJob #: 19-519Model: 74Tracking #: 0042Run #: 2Technician: AKDate: 10/8/2019

Elapsed Time (min)	Particulate Sampling Data							Fuel Weight (lb)		Temperature Data (°F)			
	Gas Meter (ft <sup>3</sup> )	Sample Rate (cfm)	Dilution Tunnel dP (in H <sub>2</sub> O)	Orifice dH (in H <sub>2</sub> O)	Meter Temp (°F)	Meter Vacuum (in Hg)	Pro. Rate (%)	Scale Reading	Weight Change	Dilution Tunnel	Flue	Filter	Ambient
297	43.377	0.146	0.100	2.07	104	-2.2	98	2.0	0	79	160	82	69
298	43.523	0.146	0.100	2.07	104	-0.72	98	2.0	0	79	160	82	69
299	43.671	0.148	0.100	2.10	104	0	99	2.0	0	79	160	82	69
300	43.819	0.148	0.100	2.10	104	-1.22	99	2.0	0	79	159	82	69
301	43.967	0.148	0.100	2.10	104	-1.18	99	2.0	0	79	159	82	69
302	44.115	0.147	0.100	2.09	104	-2.71	99	2.0	0	79	159	82	69
303	44.265	0.151	0.100	2.13	104	-0.03	101	2.0	0	78	159	82	69
304	44.414	0.148	0.100	2.10	104	0	99	2.0	0	79	159	82	69
305	44.564	0.150	0.100	2.12	104	-1.66	101	2.0	-0.04	78	159	82	69
306	44.710	0.146	0.100	2.08	104	-1.71	98	1.9	-0.06	78	159	82	69
307	44.858	0.148	0.100	2.10	104	-2	99	1.9	0	78	158	82	69
308	45.007	0.149	0.100	2.11	104	-0.56	100	1.9	0	78	159	82	69
309	45.157	0.149	0.100	2.11	104	0	100	1.9	0	78	159	82	69
310	45.305	0.148	0.100	2.10	104	-1.47	99	1.9	0	78	158	82	69
311	45.453	0.148	0.100	2.10	104	-0.41	99	1.9	0	78	158	82	69
312	45.600	0.147	0.100	2.09	104	0	99	1.9	0	78	158	82	69
313	45.748	0.147	0.100	2.09	104	0	99	1.9	0	78	158	82	69
314	45.895	0.147	0.100	2.09	104	0	99	1.8	-0.1	78	157	82	69
315	46.040	0.145	0.100	2.06	103	0	97	1.8	0	78	157	82	69
316	46.188	0.148	0.100	2.10	103	-0.5	99	1.8	0	78	157	82	69
317	46.336	0.148	0.100	2.10	103	0	99	1.8	0	78	157	82	69
318	46.483	0.147	0.100	2.09	103	-1.06	99	1.8	0	78	156	82	69
319	46.632	0.148	0.100	2.10	103	0	99	1.8	0	78	156	82	69
320	46.779	0.147	0.100	2.09	103	0	99	1.8	0	77	156	82	69
321	46.928	0.149	0.100	2.11	103	-2.73	100	1.8	0	78	156	82	69
322	47.077	0.149	0.100	2.11	103	-2.09	100	1.8	0	77	155	82	69
323	47.226	0.149	0.100	2.11	103	-2.43	100	1.8	0	77	155	82	68
324	47.378	0.152	0.100	2.14	103	-2.66	102	1.7	-0.1	77	155	82	69
325	47.528	0.150	0.100	2.12	103	-1.19	101	1.7	0	77	155	82	68
326	47.676	0.148	0.100	2.10	103	-1.43	99	1.8	0.06	77	155	82	68
327	47.829	0.153	0.100	2.15	103	-2.81	102	1.7	-0.06	77	154	82	68
328	47.979	0.150	0.100	2.12	103	-1.92	101	1.7	0	77	154	82	68
329	48.129	0.150	0.100	2.12	103	-2.52	101	1.7	0	77	154	82	68



## BOX A TEST DATA - ASTM E3053 / ASTM E2515

Client: New Buck CorporationJob #: 19-519Model: 74Tracking #: 0042Run #: 2Technician: AKDate: 10/8/2019

Elapsed Time (min)	Particulate Sampling Data							Fuel Weight (lb)		Temperature Data (°F)			
	Gas Meter (ft <sup>3</sup> )	Sample Rate (cfm)	Dilution Tunnel dP (in H <sub>2</sub> O)	Orifice dH (in H <sub>2</sub> O)	Meter Temp (°F)	Meter Vacuum (in Hg)	Pro. Rate (%)	Scale Reading	Weight Change	Dilution Tunnel	Flue	Filter	Ambient
330	48.278	0.149	0.100	2.11	103	-0.9	100	1.7	0	76	153	82	68
331	48.425	0.147	0.100	2.09	103	0	99	1.7	0	77	153	82	68
332	48.575	0.150	0.100	2.12	103	-1.59	100	1.7	0	76	153	82	68
333	48.724	0.148	0.100	2.10	103	0	99	1.7	0	76	153	82	68
334	48.873	0.149	0.100	2.11	103	0	100	1.7	-0.02	76	153	82	68
335	49.020	0.147	0.100	2.09	103	-0.67	99	1.6	-0.06	77	152	82	68
336	49.170	0.150	0.100	2.12	103	0	101	1.6	-0.02	77	152	82	68
337	49.320	0.150	0.100	2.12	103	-1.35	101	1.6	0	77	152	82	68
338	49.470	0.150	0.100	2.12	103	0	101	1.6	0	77	152	82	68
339	49.617	0.147	0.100	2.09	103	0	99	1.6	0	77	151	82	68
340	49.763	0.146	0.100	2.07	103	-0.13	98	1.6	0	77	152	82	68
341	49.915	0.152	0.100	2.14	103	-0.09	102	1.6	0	78	151	82	68
342	50.063	0.148	0.100	2.10	103	0	99	1.6	0	78	151	82	68
343	50.213	0.150	0.100	2.12	103	-0.04	101	1.6	0	78	151	82	68
344	50.361	0.148	0.100	2.10	103	-0.04	99	1.6	0	78	151	82	68
345	50.510	0.149	0.100	2.11	103	-2.89	100	1.6	0	78	151	82	69
346	50.659	0.149	0.100	2.11	103	-2.21	100	1.6	0	78	150	82	69
347	50.808	0.148	0.100	2.10	103	-1.64	100	1.6	0	79	150	82	69
348	50.955	0.147	0.100	2.09	102	-0.3	99	1.6	0	79	150	82	69
349	51.105	0.150	0.100	2.12	102	0	101	1.6	0	78	150	82	69
350	51.255	0.150	0.100	2.12	102	0	101	1.5	-0.1	78	149	82	69
351	51.405	0.150	0.100	2.12	102	-2.42	101	1.5	0	79	149	82	69
352	51.553	0.148	0.100	2.10	102	-0.34	100	1.5	0	79	148	82	69
353	51.701	0.148	0.100	2.10	102	0	100	1.5	0	79	148	82	69
354	51.851	0.149	0.100	2.11	102	-2.29	100	1.6	0.06	78	147	82	69
355	51.999	0.148	0.100	2.10	102	0	100	1.5	-0.06	78	147	82	69
356	52.147	0.148	0.100	2.10	102	-2.53	100	1.6	0.1	79	147	82	68
357	52.294	0.147	0.100	2.09	102	0	99	1.5	-0.1	79	147	82	69
358	52.443	0.148	0.100	2.10	102	0	100	1.5	0	79	146	82	69
359	52.592	0.149	0.100	2.11	102	0	100	1.5	0	78	146	82	69
360	52.741	0.149	0.100	2.11	102	-2.69	100	1.5	0	78	145	82	69
361	52.892	0.151	0.100	2.13	102	-0.27	102	1.5	0	79	145	82	69
362	53.039	0.147	0.100	2.09	102	-0.73	99	1.5	0	79	145	82	69

## BOX A TEST DATA - ASTM E3053 / ASTM E2515

Client: New Buck CorporationJob #: 19-519Model: 74Tracking #: 0042Run #: 2Technician: AKDate: 10/8/2019

Elapsed Time (min)	Particulate Sampling Data							Fuel Weight (lb)		Temperature Data (°F)			
	Gas Meter (ft <sup>3</sup> )	Sample Rate (cfm)	Dilution Tunnel dP (in H <sub>2</sub> O)	Orifice dH (in H <sub>2</sub> O)	Meter Temp (°F)	Meter Vacuum (in Hg)	Pro. Rate (%)	Scale Reading	Weight Change	Dilution Tunnel	Flue	Filter	Ambient
363	53.188	0.149	0.100	2.11	102	-2.41	100	1.5	0	79	145	82	69
364	53.338	0.150	0.100	2.12	102	0	101	1.5	0	79	144	82	69
365	53.488	0.150	0.100	2.12	102	-2.29	101	1.4	-0.06	79	144	82	69
366	53.635	0.147	0.100	2.09	102	-1.32	99	1.4	-0.04	79	144	82	69
367	53.785	0.150	0.100	2.12	102	-1.93	101	1.4	0	79	143	82	69
368	53.934	0.148	0.100	2.10	102	0	100	1.4	0	79	144	82	69
369	54.085	0.151	0.100	2.13	102	0	102	1.4	0	79	143	82	69
370	54.234	0.149	0.100	2.11	102	-1.52	100	1.4	0	79	143	82	69
371	54.382	0.148	0.100	2.10	102	-0.36	100	1.4	0	79	143	82	69
372	54.535	0.153	0.100	2.15	102	-2.75	103	1.4	0	79	143	82	69
373	54.685	0.150	0.100	2.12	102	0	101	1.4	0	79	142	82	69
374	54.835	0.150	0.100	2.12	102	-2.73	101	1.4	-0.02	79	142	82	69
375	54.984	0.149	0.100	2.11	102	0	100	1.4	0	79	141	82	69
376	55.131	0.147	0.100	2.09	102	-2.43	99	1.4	0.02	79	141	82	69
377	55.280	0.149	0.100	2.11	102	-0.84	100	1.3	-0.1	79	141	82	69
378	55.430	0.150	0.100	2.12	102	-2.5	101	1.3	0	79	141	82	69
379	55.580	0.150	0.100	2.12	102	-1.4	101	1.3	0	79	140	82	69
380	55.730	0.150	0.100	2.12	102	-2.28	101	1.3	0	79	141	82	69
381	55.878	0.148	0.100	2.10	102	-1.74	100	1.3	0	79	140	82	69
382	56.026	0.147	0.100	2.09	102	-2.57	99	1.3	0	79	140	82	69
383	56.178	0.152	0.100	2.14	102	0	102	1.3	0	79	140	82	69
384	56.324	0.146	0.100	2.08	102	-2.29	99	1.3	0	80	140	82	69
385	56.475	0.151	0.100	2.13	102	-2.83	102	1.3	0	79	140	82	69
386	56.628	0.154	0.100	2.16	102	-2.87	103	1.2	-0.1	79	140	82	69
387	56.778	0.150	0.100	2.12	102	-0.29	101	1.2	0	80	140	82	69
388	56.928	0.149	0.100	2.11	102	-2.78	100	1.2	0	79	140	82	69
389	57.078	0.150	0.100	2.12	102	-0.05	101	1.2	0	80	140	82	69
390	57.230	0.153	0.100	2.15	102	-0.34	103	1.2	0	79	139	82	69
391	57.381	0.151	0.100	2.13	102	-2.43	102	1.2	0	79	140	82	69
392	57.530	0.149	0.100	2.11	102	-1.52	100	1.2	0	79	139	82	69
393	57.679	0.149	0.100	2.11	102	-0.06	100	1.2	0	80	139	82	69
394	57.827	0.147	0.100	2.09	102	0	99	1.2	0	80	139	82	69
395	57.977	0.150	0.100	2.12	102	-1.71	101	1.2	0	79	139	82	69

## BOX A TEST DATA - ASTM E3053 / ASTM E2515

Client: New Buck CorporationJob #: 19-519Model: 74Tracking #: 0042Run #: 2Technician: AKDate: 10/8/2019

Elapsed Time (min)	Particulate Sampling Data							Fuel Weight (lb)		Temperature Data (°F)			
	Gas Meter (ft <sup>3</sup> )	Sample Rate (cfm)	Dilution Tunnel dP (in H <sub>2</sub> O)	Orifice dH (in H <sub>2</sub> O)	Meter Temp (°F)	Meter Vacuum (in Hg)	Pro. Rate (%)	Scale Reading	Weight Change	Dilution Tunnel	Flue	Filter	Ambient
396	58.128	0.151	0.100	2.13	102	-1.14	102	1.2	0	79	139	82	69
397	58.277	0.149	0.100	2.11	102	-2.29	100	1.2	0	79	139	82	69
398	58.428	0.151	0.100	2.13	102	-0.18	102	1.2	0	79	138	82	69
399	58.579	0.151	0.100	2.13	102	0	102	1.2	0	79	138	82	69
400	58.729	0.150	0.100	2.12	102	-1.68	101	1.2	0	79	138	82	69
401	58.878	0.149	0.100	2.11	102	0	100	1.1	-0.1	79	138	82	69
402	59.030	0.153	0.100	2.15	102	-2.47	103	1.1	0	79	138	82	69
403	59.183	0.153	0.100	2.15	102	0	103	1.2	0.1	79	138	82	69
404	59.333	0.150	0.100	2.12	102	-1.2	101	1.1	-0.1	78	138	82	69
405	59.485	0.152	0.100	2.14	102	0	102	1.1	0	79	138	82	69
406	59.632	0.147	0.100	2.09	101	-1.69	99	1.1	0	79	138	82	69
407	59.785	0.153	0.100	2.15	101	-2.23	103	1.1	0	79	138	82	69
408	59.935	0.150	0.100	2.12	101	-2.41	101	1.1	0	78	137	82	69
409	60.084	0.149	0.100	2.11	101	0	100	1.1	0	78	137	82	69
410	60.233	0.149	0.100	2.11	101	0	100	1.0	-0.1	78	137	82	69
411	60.382	0.149	0.100	2.11	101	-1.74	100	1.0	0	78	137	82	69
412	60.534	0.152	0.100	2.14	101	-0.08	102	1.0	0	79	137	82	69
413	60.687	0.153	0.100	2.15	101	-2.72	103	1.0	0.02	79	137	82	69
414	60.835	0.148	0.100	2.10	101	0	100	1.0	-0.02	78	137	82	69
415	60.988	0.153	0.100	2.15	101	-2.78	103	1.1	0.1	79	137	82	68
416	61.138	0.151	0.100	2.13	101	-0.92	102	1.1	0	79	138	82	68
417	61.290	0.152	0.100	2.14	101	-2.65	102	1.0	-0.1	79	137	82	68
418	61.439	0.149	0.100	2.11	101	-0.42	101	1.0	0	79	137	82	68
419	61.590	0.151	0.100	2.13	101	-2.52	102	1.0	0	78	137	82	68
420	61.741	0.151	0.100	2.13	101	-0.41	102	1.0	0	78	137	82	68
421	61.890	0.149	0.100	2.11	101	0	100	1.0	0	78	137	82	69
422	62.041	0.151	0.100	2.13	101	-2.77	102	1.0	0	78	137	82	69
423	62.191	0.150	0.100	2.12	101	-2.35	101	0.9	-0.06	78	136	82	69
424	62.341	0.150	0.100	2.12	101	-2.18	101	0.9	-0.02	78	137	82	69
425	62.491	0.150	0.100	2.12	101	0	101	1.0	0.08	79	137	82	68
426	62.644	0.153	0.100	2.15	101	-1.28	103	1.0	0	79	137	82	68
427	62.796	0.152	0.100	2.14	101	-2.72	102	0.9	-0.1	79	137	82	68
428	62.946	0.150	0.100	2.12	101	-1.25	101	0.9	0	79	137	82	68

## BOX A TEST DATA - ASTM E3053 / ASTM E2515

Client: New Buck CorporationJob #: 19-519Model: 74Tracking #: 0042Run #: 2Technician: AKDate: 10/8/2019

Elapsed Time (min)	Particulate Sampling Data							Fuel Weight (lb)		Temperature Data (°F)			
	Gas Meter (ft <sup>3</sup> )	Sample Rate (cfm)	Dilution Tunnel dP (in H <sub>2</sub> O)	Orifice dH (in H <sub>2</sub> O)	Meter Temp (°F)	Meter Vacuum (in Hg)	Pro. Rate (%)	Scale Reading	Weight Change	Dilution Tunnel	Flue	Filter	Ambient
429	63.097	0.151	0.100	2.13	101	0	102	0.9	0	79	137	82	68
430	63.247	0.150	0.100	2.12	101	-2.48	101	0.9	0	79	137	82	68
431	63.397	0.150	0.100	2.12	101	-2.67	101	0.9	0	78	137	82	68
432	63.547	0.151	0.100	2.13	101	0	102	0.9	0	79	137	82	68
433	63.697	0.150	0.100	2.12	101	-1.91	101	0.9	0	79	137	82	68
434	63.848	0.151	0.100	2.13	101	0	102	0.9	0	79	137	82	68
435	64.000	0.152	0.100	2.14	101	-0.43	102	0.9	0	78	137	82	68
436	64.152	0.152	0.100	2.14	101	-2.16	102	0.9	0	78	137	82	68
437	64.305	0.153	0.100	2.15	101	0	103	0.9	-0.02	79	136	82	68
438	64.455	0.150	0.100	2.12	101	-0.2	101	0.8	-0.08	78	136	82	68
439	64.606	0.151	0.100	2.13	101	0	102	0.9	0.1	78	136	82	68
440	64.757	0.152	0.100	2.14	101	0	102	0.8	-0.1	78	136	82	68
441	64.908	0.151	0.100	2.13	101	0	102	0.8	0	78	136	82	68
442	65.058	0.150	0.100	2.12	101	0	101	0.8	0	78	136	82	68
443	65.208	0.150	0.100	2.12	101	-2.67	101	0.8	0	78	136	82	68
444	65.360	0.152	0.100	2.14	101	-2.66	102	0.8	0	78	136	82	68
445	65.512	0.152	0.100	2.14	101	-1.47	102	0.8	0	78	135	82	68
446	65.663	0.151	0.100	2.13	101	-1.37	102	0.8	0	78	135	82	68
447	65.814	0.151	0.100	2.13	101	0	102	0.8	0	78	136	82	68
448	65.964	0.150	0.100	2.12	101	-0.8	101	0.8	0	78	136	82	68
449	66.114	0.151	0.100	2.13	101	-2.28	102	0.8	0	77	136	82	68
450	66.266	0.152	0.100	2.14	101	-2.42	102	0.8	0	78	135	82	68
451	66.417	0.151	0.100	2.13	101	-0.99	102	0.8	0	78	135	82	68
452	66.566	0.149	0.100	2.11	101	0	100	0.8	0	77	135	82	68
453	66.717	0.151	0.100	2.13	101	-2.64	102	0.8	0	77	135	82	68
454	66.866	0.149	0.100	2.11	101	-1.53	100	0.8	-0.02	77	134	82	68
455	67.015	0.149	0.100	2.11	101	-1.78	100	0.8	0.02	77	134	82	68
456	67.167	0.152	0.100	2.14	101	-0.45	102	0.8	0	77	134	82	68
457	67.318	0.151	0.100	2.13	101	-2.68	102	0.7	-0.1	77	134	82	68
458	67.471	0.153	0.100	2.15	101	-2.85	103	0.7	0	77	134	82	68
459	67.620	0.149	0.100	2.11	101	0	100	0.7	0	77	134	82	68
460	67.773	0.153	0.100	2.15	101	-0.73	103	0.7	0	77	134	82	68
461	67.925	0.153	0.100	2.15	101	-0.17	103	0.7	0	77	134	82	67

## BOX A TEST DATA - ASTM E3053 / ASTM E2515

Client: New Buck Corporation  
 Model: 74  
 Run #: 2

Job #: 19-519  
 Tracking #: 0042  
 Technician: AK  
 Date: 10/8/2019

Elapsed Time (min)	Particulate Sampling Data							Fuel Weight (lb)		Temperature Data (°F)			
	Gas Meter (ft <sup>3</sup> )	Sample Rate (cfm)	Dilution Tunnel dP (in H <sub>2</sub> O)	Orifice dH (in H <sub>2</sub> O)	Meter Temp (°F)	Meter Vacuum (in Hg)	Pro. Rate (%)	Scale Reading	Weight Change	Dilution Tunnel	Flue	Filter	Ambient
462	68.074	0.149	0.100	2.11	101	0	100	0.7	0	77	134	82	68
463	68.226	0.152	0.100	2.14	101	-0.2	102	0.7	0	77	133	82	68
464	68.377	0.151	0.100	2.13	101	-2.57	101	0.7	0	76	133	82	68
465	68.528	0.151	0.100	2.13	101	-0.29	101	0.7	0	76	133	81	68
466	68.680	0.152	0.100	2.14	101	-0.01	102	0.7	0	76	133	81	68
467	68.830	0.150	0.100	2.12	101	0	101	0.7	0	76	133	82	68
468	68.979	0.149	0.100	2.11	101	-1.48	100	0.7	0	76	133	82	68
469	69.130	0.151	0.100	2.13	101	0	101	0.6	-0.1	76	132	82	67
470	69.281	0.151	0.100	2.13	100	-2.13	102	0.6	0	76	132	82	67
471	69.432	0.152	0.100	2.14	100	-2.64	102	0.6	0	76	132	82	67
472	69.583	0.151	0.100	2.13	100	-0.3	102	0.6	0	76	132	82	67
473	69.737	0.154	0.100	2.16	100	-1.77	103	0.6	0	76	132	81	67
474	69.888	0.151	0.100	2.13	100	-2.39	102	0.6	0	76	132	81	67
475	70.041	0.154	0.100	2.16	100	0	103	0.5	-0.08	76	132	81	67
476	70.191	0.150	0.100	2.12	100	-1.08	101	0.6	0.08	76	132	82	67
477	70.343	0.152	0.100	2.14	100	-0.76	102	0.6	0	76	132	82	67
478	70.493	0.150	0.100	2.12	100	0	101	0.6	0	76	132	82	67
479	70.644	0.151	0.100	2.13	100	-0.43	102	0.6	0	76	132	82	67
480	70.791	0.146	0.100	2.08	100	0	99	0.6	0	76	131	82	67
481	70.937	0.146	0.100	2.08	100	0	99	0.6	0	76	131	81	67
482	71.084	0.147	0.100	2.09	100	-1.05	99	0.5	-0.1	76	131	81	67
483	71.229	0.145	0.100	2.06	100	0	97	0.5	0	75	131	81	67
484	71.375	0.146	0.100	2.07	100	-0.33	98	0.5	0	75	131	82	67
485	71.523	0.148	0.100	2.10	100	-2.36	100	0.5	0	75	131	82	67
486	71.669	0.146	0.100	2.08	100	-0.71	99	0.5	0	75	131	82	67
487	71.816	0.146	0.100	2.08	100	-0.2	99	0.5	0	75	131	82	67
488	71.961	0.146	0.100	2.07	100	0	98	0.5	0	75	130	82	67
489	72.110	0.149	0.100	2.11	100	-1.37	100	0.5	0	75	130	81	67
490	72.259	0.149	0.100	2.11	100	-0.98	100	0.5	0	75	130	81	67
491	72.408	0.149	0.100	2.11	100	-2.15	100	0.5	0	74	130	81	67
492	72.555	0.146	0.100	2.08	100	0	98	0.5	0	74	129	81	66
493	72.703	0.148	0.100	2.10	100	-2.51	100	0.5	0	74	130	82	66
494	72.850	0.147	0.100	2.09	100	-1.47	99	0.4	-0.1	74	129	82	66

## BOX A TEST DATA - ASTM E3053 / ASTM E2515

Client: New Buck CorporationJob #: 19-519Model: 74Tracking #: 0042Run #: 2Technician: AKDate: 10/8/2019

Elapsed Time (min)	Particulate Sampling Data							Fuel Weight (lb)		Temperature Data (°F)			
	Gas Meter (ft <sup>3</sup> )	Sample Rate (cfm)	Dilution Tunnel dP (in H <sub>2</sub> O)	Orifice dH (in H <sub>2</sub> O)	Meter Temp (°F)	Meter Vacuum (in Hg)	Pro. Rate (%)	Scale Reading	Weight Change	Dilution Tunnel	Flue	Filter	Ambient
495	72.998	0.147	0.100	2.09	100	-2.56	99	0.4	0	74	129	82	66
496	73.146	0.148	0.100	2.10	100	-2.68	100	0.4	0	74	129	82	66
497	73.293	0.147	0.100	2.09	100	0	99	0.4	0	74	129	82	66
498	73.442	0.149	0.100	2.11	100	0	100	0.4	0	74	129	82	66
499	73.592	0.149	0.100	2.11	100	-2.17	100	0.4	0	74	128	81	66
500	73.740	0.148	0.100	2.10	100	-2.2	100	0.4	0	74	128	81	66
501	73.885	0.146	0.100	2.07	100	-2.49	98	0.4	0	74	128	81	66
502	74.034	0.148	0.100	2.10	100	-0.33	100	0.4	0	74	128	82	66
503	74.181	0.147	0.100	2.09	100	-2.53	99	0.4	0	73	128	82	66
504	74.330	0.149	0.100	2.11	100	0	100	0.4	0	74	127	82	66
505	74.477	0.147	0.100	2.09	100	-2.63	99	0.4	0	74	127	82	66
506	74.626	0.148	0.100	2.10	100	-2.31	100	0.4	0	74	127	82	66
507	74.773	0.147	0.100	2.09	100	-2.45	99	0.4	0	74	127	82	66
508	74.921	0.148	0.100	2.10	100	-2.44	100	0.4	0	73	126	82	66
509	75.071	0.150	0.100	2.12	100	0	101	0.4	0	73	126	82	66
510	75.221	0.150	0.100	2.12	100	-2.53	101	0.4	0	73	126	82	66
511	75.368	0.147	0.100	2.09	100	0	99	0.4	0	73	126	82	66
512	75.514	0.146	0.100	2.07	100	-2.06	98	0.3	-0.1	73	126	82	66
513	75.660	0.146	0.100	2.08	100	-1.97	98	0.3	0	73	125	82	66
514	75.808	0.147	0.100	2.09	100	-2.6	99	0.3	0	73	125	82	66
515	75.957	0.149	0.100	2.11	100	-0.75	100	0.3	0	73	125	82	66
516	76.105	0.148	0.100	2.10	100	-2.25	100	0.3	0	73	124	82	66
517	76.252	0.147	0.100	2.09	100	-0.3	99	0.3	0	73	124	82	65
518	76.398	0.146	0.100	2.07	100	-0.7	98	0.3	0	73	123	82	66
519	76.544	0.146	0.100	2.08	99	0	99	0.3	0	73	124	82	65
520	76.690	0.146	0.100	2.07	99	-1.38	98	0.3	0	73	123	82	65
521	76.835	0.146	0.100	2.07	99	0	98	0.3	0	73	123	82	65
522	76.983	0.147	0.100	2.09	99	-0.35	99	0.3	0	73	123	82	65
523	77.130	0.147	0.100	2.09	99	0	99	0.3	0	73	122	82	65
524	77.278	0.148	0.100	2.10	99	0	100	0.3	0	72	122	82	65
525	77.427	0.148	0.100	2.10	99	0	100	0.3	0	72	121	82	65
526	77.574	0.147	0.100	2.09	99	0	99	0.3	0	73	121	82	65
527	77.724	0.150	0.100	2.12	99	-0.19	101	0.3	0	72	121	82	65

## BOX A TEST DATA - ASTM E3053 / ASTM E2515

Client: New Buck CorporationJob #: 19-519Model: 74Tracking #: 0042Run #: 2Technician: AKDate: 10/8/2019

Elapsed Time (min)	Particulate Sampling Data							Fuel Weight (lb)		Temperature Data (°F)			
	Gas Meter (ft <sup>3</sup> )	Sample Rate (cfm)	Dilution Tunnel dP (in H <sub>2</sub> O)	Orifice dH (in H <sub>2</sub> O)	Meter Temp (°F)	Meter Vacuum (in Hg)	Pro. Rate (%)	Scale Reading	Weight Change	Dilution Tunnel	Flue	Filter	Ambient
528	77.871	0.147	0.100	2.09	99	-2.37	99	0.2	-0.1	72	121	82	65
529	78.019	0.148	0.100	2.10	99	-0.64	100	0.2	0	72	121	82	65
530	78.169	0.149	0.100	2.11	99	-1.22	100	0.3	0.1	72	120	82	65
531	78.317	0.148	0.100	2.10	99	-2.79	100	0.2	-0.1	72	120	82	65
532	78.463	0.146	0.100	2.08	99	0	98	0.2	0	72	120	81	65
533	78.610	0.146	0.100	2.08	99	-1.64	98	0.2	0	72	119	81	65
534	78.758	0.148	0.100	2.10	99	0	100	0.2	0	72	119	82	65
535	78.907	0.149	0.100	2.11	99	0	100	0.2	0	72	119	82	65
536	79.057	0.150	0.100	2.12	99	-2.33	101	0.2	0	72	118	82	65
537	79.206	0.149	0.100	2.11	99	-1.59	100	0.2	0	72	118	82	65
538	79.354	0.148	0.100	2.10	99	0	100	0.2	0	72	118	82	65
539	79.503	0.149	0.100	2.11	99	0	100	0.2	0	71	118	82	65
540	79.654	0.151	0.100	2.13	99	-2.05	101	0.2	0	71	117	82	65
541	79.804	0.150	0.100	2.12	99	-1.98	101	0.2	0	71	117	81	65
542	79.953	0.149	0.100	2.11	99	0	100	0.2	0	71	117	81	65
543	80.101	0.147	0.100	2.09	99	0	99	0.2	0	71	117	81	64
544	80.246	0.146	0.100	2.07	99	-0.85	98	0.2	0	71	117	81	64
545	80.394	0.147	0.100	2.09	99	-1.31	99	0.2	0	71	116	82	65
546	80.543	0.149	0.100	2.11	99	-2.45	100	0.2	0	71	116	82	64
547	80.695	0.152	0.100	2.14	99	0	102	0.2	0	71	116	82	64
548	80.843	0.148	0.100	2.10	99	-0.76	100	0.2	0	71	115	82	65
549	80.990	0.147	0.100	2.09	99	-2.15	99	0.1	-0.1	71	115	82	64
550	81.139	0.149	0.100	2.11	99	-2.04	100	0.2	0.1	71	115	82	64
551	81.290	0.151	0.100	2.13	99	-0.75	101	0.2	0	71	115	81	64
552	81.438	0.148	0.100	2.10	99	-0.73	100	0.1	-0.1	71	115	81	64
553	81.586	0.147	0.100	2.09	99	0	99	0.1	0	71	115	81	64
554	81.733	0.147	0.100	2.09	99	-2	99	0.1	0	71	114	81	64
555	81.883	0.150	0.100	2.12	98	-2.41	101	0.1	0	71	113	81	64
556	82.034	0.151	0.100	2.13	98	-0.38	102	0.2	0.06	71	113	82	64
557	82.183	0.149	0.100	2.11	98	-2.48	100	0.1	-0.06	71	113	82	64
558	82.333	0.150	0.100	2.12	98	0	101	0.1	0	71	113	82	64
559	82.482	0.149	0.100	2.11	98	-2.49	100	0.1	0	71	113	82	64
560	82.630	0.148	0.100	2.10	98	-0.04	100	0.1	0	70	112	82	64











# BOX B TEST DATA - ASTM E3053 / ASTM E2515

Client: New Buck Corporation  
 Model: 74  
 Run #: 2

Job #: 19-519  
 Tracking #: 0042  
 Technician: AK  
 Date: 10/8/2019

Elapsed Time (min)	Particulate Sampling Data							Flue Gas Data		
	Gas Meter (ft <sup>3</sup> )	Sample Rate (cfm)	Orifice dH (in H <sub>2</sub> O)	Meter Temp (°F)	Meter Vacuum (in Hg)	Pro. Rate (%)	Filter (°F)	Flue Draft (in H <sub>2</sub> O)	CO <sub>2</sub> (%)	CO (%)
0	0.000		0.00	100	-1		82	0.000	4.91	0.20
1	0.144	0.144	2.05	99	0	111	84	0.020	3.02	0.33
2	0.286	0.142	2.01	99	-1.32	106	85	0.040	2.26	0.64
3	0.429	0.143	2.02	99	-0.15	107	87	0.070	7.32	1.20
4	0.570	0.142	2.00	99	-1.81	107	87	0.090	11.70	0.50
5	0.713	0.143	2.02	99	-0.03	108	88	0.110	15.09	0.41
6	0.859	0.147	2.10	99	-0.62	111	88	0.110	16.58	0.65
7	1.005	0.146	2.08	98	-1.04	110	88	0.100	16.82	1.25
8	1.150	0.145	2.07	98	-0.88	110	89	0.120	15.72	0.71
9	1.295	0.145	2.07	98	-2.76	110	89	0.100	15.47	0.65
10	1.440	0.145	2.07	98	-2.71	110	89	0.110	16.14	0.89
11	1.583	0.143	2.03	98	-2.77	108	89	0.110	16.88	2.29
12	1.727	0.144	2.05	98	-2.2	109	90	0.080	16.89	2.39
13	1.876	0.149	2.14	98	-0.25	112	90	0.070	16.90	2.45
14	2.024	0.148	2.13	98	-2.77	111	90	0.080	15.50	2.54
15	2.171	0.147	2.11	98	-0.51	109	90	0.070	11.35	1.87
16	2.316	0.146	2.08	99	-3.07	108	90	0.090	10.42	1.99
17	2.460	0.144	2.05	99	-0.62	107	89	0.070	10.11	1.90
18	2.609	0.149	2.15	99	-1.27	110	89	0.110	9.84	1.87
19	2.756	0.147	2.10	99	-2.63	108	89	0.060	9.87	1.89
20	2.899	0.144	2.04	99	-0.75	106	89	0.030	11.09	1.78
21	3.041	0.142	2.01	99	-1.48	105	89	0.120	11.52	1.65
22	3.181	0.140	1.96	99	-2.6	103	89	0.040	11.66	1.72
23	3.334	0.153	2.23	99	-3.55	113	89	0.080	12.21	1.50
24	3.479	0.145	2.07	99	-1.47	101	89	0.050	13.28	1.38
25	3.623	0.144	2.05	99	-1.38	106	89	0.120	13.30	1.39
26	3.766	0.143	2.02	100	-1.55	105	89	0.070	14.03	1.29
27	3.908	0.143	2.02	100	-3.74	99	88	0.060	13.90	1.33
28	4.051	0.143	2.03	100	-3.68	100	88	0.120	13.91	1.37
29	4.192	0.141	1.98	100	-3.9	103	88	0.100	14.03	1.28
30	4.335	0.144	2.04	100	-3.08	105	88	0.070	14.27	1.10
31	4.478	0.143	2.02	100	-3.2	105	88	0.070	14.17	1.05

## BOX B TEST DATA - ASTM E3053 / ASTM E2515

Client: New Buck Corporation  
 Model: 74  
 Run #: 2

Job #: 19-519  
 Tracking #: 0042  
 Technician: AK  
 Date: 10/8/2019

Elapsed Time (min)	Particulate Sampling Data							Flue Gas Data		
	Gas Meter (ft <sup>3</sup> )	Sample Rate (cfm)	Orifice dH (in H <sub>2</sub> O)	Meter Temp (°F)	Meter Vacuum (in Hg)	Pro. Rate (%)	Filter (°F)	Flue Draft (in H <sub>2</sub> O)	CO <sub>2</sub> (%)	CO (%)
32	4.618	0.141	1.98	100	-3.97	98	87	0.050	13.63	1.15
33	4.763	0.145	2.06	100	-1.92	106	87	0.030	13.32	1.18
34	4.904	0.142	2.00	100	-1.94	98	87	0.070	13.44	1.28
35	5.048	0.144	2.04	101	-2.99	105	87	0.080	13.16	1.30
36	5.188	0.141	1.98	101	-3.39	103	87	0.070	13.41	1.26
37	5.324	0.136	1.89	101	-3.36	94	86	0.070	13.57	1.20
38	5.470	0.146	2.09	101	-3.1	107	86	0.010	13.42	1.39
39	5.617	0.147	2.10	101	-2.67	107	84	0.080	13.88	1.25
40	5.764	0.147	2.10	101	-1.5	107	85	0.030	13.85	1.13
41	5.910	0.146	2.09	101	-2.13	101	85	0.050	13.70	1.08
42	6.056	0.146	2.09	101	-0.85	101	85	0.080	13.65	1.29
43	6.201	0.146	2.08	101	-0.63	101	85	0.100	13.50	1.07
44	6.348	0.147	2.10	101	-0.53	102	85	0.000	13.30	1.06
45	6.494	0.147	2.10	101	-0.03	102	86	0.030	13.35	1.05
46	6.640	0.146	2.08	101	-2.6	106	87	0.050	13.29	1.01
47	6.785	0.146	2.08	102	-0.1	106	87	0.080	13.63	1.02
48	6.932	0.147	2.10	102	0	107	88	0.070	13.26	1.07
49	7.078	0.146	2.09	102	-2.79	101	88	0.120	13.61	0.96
50	7.224	0.146	2.09	102	-2.25	101	88	0.040	13.25	1.00
51	7.371	0.147	2.10	102	-2.76	101	88	0.100	13.39	0.99
52	7.517	0.146	2.09	102	-0.04	101	88	0.070	13.24	1.08
53	7.662	0.146	2.08	102	-0.79	101	88	0.080	13.29	1.07
54	7.809	0.147	2.10	102	-0.13	101	88	0.050	13.22	1.12
55	7.955	0.146	2.09	102	0	101	87	0.110	13.17	1.08
56	8.101	0.147	2.10	102	0	101	87	0.030	13.01	1.09
57	8.246	0.145	2.06	102	-0.65	100	87	0.080	12.19	1.51
58	8.392	0.146	2.09	102	-0.87	101	86	0.090	12.50	1.26
59	8.539	0.147	2.11	102	0	102	86	0.060	12.48	1.28
60	8.685	0.146	2.09	102	0	101	86	0.080	12.59	1.20
61	8.832	0.147	2.11	102	-2.68	102	86	0.070	12.79	1.17
62	8.977	0.145	2.07	102	-2.63	100	86	0.060	12.52	1.15
63	9.123	0.146	2.09	102	-0.92	101	86	0.050	12.74	1.12

# BOX B TEST DATA - ASTM E3053 / ASTM E2515

Client: New Buck Corporation

Job #: 19-519

Model: 74

Tracking #: 0042

Run #: 2

Technician: AK

Date: 10/8/2019

Elapsed Time (min)	Particulate Sampling Data							Flue Gas Data		
	Gas Meter (ft <sup>3</sup> )	Sample Rate (cfm)	Orifice dH (in H <sub>2</sub> O)	Meter Temp (°F)	Meter Vacuum (in Hg)	Pro. Rate (%)	Filter (°F)	Flue Draft (in H <sub>2</sub> O)	CO <sub>2</sub> (%)	CO (%)
64	9.269	0.146	2.09	103	-1.91	101	86	0.070	12.80	1.18
65	9.416	0.147	2.10	103	-2.56	101	86	0.080	12.85	1.19
66	9.563	0.147	2.11	103	-2.39	101	85	0.030	12.66	1.29
67	9.709	0.147	2.10	103	-0.14	101	85	0.060	12.94	1.10
68	9.853	0.144	2.04	103	-1.3	99	86	0.070	13.18	1.13
69	9.998	0.145	2.07	103	-2.24	105	87	0.080	12.92	1.16
70	10.143	0.145	2.07	103	-0.12	100	87	0.080	12.84	1.20
71	10.288	0.145	2.07	103	0	100	88	0.030	13.25	1.14
72	10.434	0.146	2.08	103	-2.55	106	89	0.120	13.48	1.17
73	10.579	0.146	2.08	103	-2.88	100	89	0.080	13.38	1.18
74	10.725	0.146	2.08	103	-0.1	100	89	0.060	13.57	1.15
75	10.870	0.146	2.08	103	-0.27	100	89	0.090	13.76	1.10
76	11.017	0.147	2.10	103	0	101	89	0.080	13.43	1.16
77	11.162	0.146	2.08	103	-2.65	100	89	0.100	13.20	1.29
78	11.308	0.146	2.09	103	-2.06	101	89	-0.030	13.49	1.26
79	11.455	0.147	2.10	103	0	101	88	0.030	13.51	1.24
80	11.601	0.146	2.09	103	-0.52	101	88	0.050	13.42	1.24
81	11.745	0.145	2.06	103	-1.25	100	87	0.070	13.50	1.22
82	11.891	0.146	2.08	103	-2.1	100	87	0.030	13.72	1.11
83	12.037	0.146	2.09	103	-0.26	101	87	0.050	13.75	1.07
84	12.183	0.146	2.09	103	-2.45	101	87	0.050	13.97	1.09
85	12.330	0.147	2.10	103	-2.19	101	86	0.090	14.01	1.12
86	12.475	0.145	2.07	103	-2.72	105	86	0.070	14.16	1.09
87	12.621	0.146	2.09	103	-0.06	101	86	0.100	14.34	1.04
88	12.766	0.146	2.08	103	-1.89	100	86	0.030	14.07	1.07
89	12.912	0.146	2.08	103	-1.59	100	86	0.110	14.08	1.08
90	13.057	0.145	2.07	103	-2.8	100	86	0.050	14.33	1.15
91	13.202	0.146	2.08	103	-2.68	100	86	0.090	14.13	1.18
92	13.348	0.146	2.09	103	-2.36	101	87	0.080	13.81	1.07
93	13.494	0.146	2.09	103	-0.62	101	88	0.110	13.48	1.06
94	13.640	0.146	2.08	103	-2.44	100	89	0.070	13.36	1.05
95	13.785	0.145	2.07	103	-2.69	105	89	0.050	13.52	1.03

# BOX B TEST DATA - ASTM E3053 / ASTM E2515

Client: New Buck Corporation

Job #: 19-519

Model: 74

Tracking #: 0042

Run #: 2

Technician: AK

Date: 10/8/2019

Elapsed Time (min)	Particulate Sampling Data							Flue Gas Data		
	Gas Meter (ft <sup>3</sup> )	Sample Rate (cfm)	Orifice dH (in H <sub>2</sub> O)	Meter Temp (°F)	Meter Vacuum (in Hg)	Pro. Rate (%)	Filter (°F)	Flue Draft (in H <sub>2</sub> O)	CO <sub>2</sub> (%)	CO (%)
96	13.930	0.145	2.06	103	-0.7	99	90	0.070	13.75	1.00
97	14.075	0.145	2.07	103	-0.48	100	90	0.060	13.35	1.00
98	14.220	0.146	2.08	103	-1.19	100	90	0.060	13.64	0.91
99	14.366	0.146	2.09	103	0	101	90	0.060	13.74	0.90
100	14.512	0.146	2.09	103	-1.46	100	89	0.060	13.85	0.84
101	14.658	0.146	2.09	103	-2.7	100	89	0.040	13.80	0.77
102	14.804	0.146	2.08	103	-0.13	100	88	0.050	13.52	0.66
103	14.950	0.146	2.09	103	-2.44	100	88	0.050	13.49	0.65
104	15.096	0.147	2.10	103	-0.13	106	88	0.060	13.68	0.59
105	15.242	0.146	2.08	103	-0.01	100	87	0.040	13.36	0.64
106	15.388	0.146	2.09	103	-0.71	100	87	0.040	13.08	0.57
107	15.534	0.146	2.09	103	-2.39	100	87	0.060	12.85	0.36
108	15.679	0.145	2.07	103	-2.7	100	87	0.070	12.62	0.34
109	15.825	0.146	2.08	103	-1.89	100	86	0.060	12.53	0.31
110	15.971	0.146	2.09	103	-2.61	100	86	0.060	12.56	0.34
111	16.117	0.146	2.09	103	-2.74	100	86	0.060	12.43	0.26
112	16.263	0.147	2.10	103	-1.03	101	86	0.050	12.57	0.31
113	16.409	0.146	2.08	103	-0.03	100	87	0.070	12.65	0.27
114	16.555	0.146	2.09	103	0	100	87	0.050	12.64	0.31
115	16.700	0.146	2.08	103	-2.45	100	88	0.050	12.67	0.24
116	16.846	0.145	2.07	103	-2.73	100	88	0.060	12.58	0.37
117	16.992	0.147	2.10	104	-0.14	100	88	0.060	12.72	0.32
118	17.138	0.146	2.09	107	-0.26	100	88	0.050	12.62	0.34
119	17.284	0.146	2.09	107	-2.71	100	88	0.030	12.21	0.31
120	17.429	0.145	2.07	104	-2.57	99	88	0.050	12.28	0.21
121	17.575	0.146	2.08	104	-2.54	100	88	0.070	11.85	0.26
122	17.721	0.146	2.09	104	-2.7	105	88	0.050	11.81	0.25
123	17.867	0.146	2.09	104	-0.23	100	88	0.070	11.73	0.27
124	18.012	0.146	2.08	104	-1.56	100	88	0.050	11.59	0.32
125	18.158	0.146	2.08	103	-2.31	105	88	0.070	11.37	0.37
126	18.304	0.146	2.09	103	-1.08	100	86	0.050	11.29	0.40
127	18.450	0.146	2.08	103	-2.5	100	86	0.050	11.53	0.35

## BOX B TEST DATA - ASTM E3053 / ASTM E2515

Client: New Buck CorporationJob #: 19-519Model: 74Tracking #: 0042Run #: 2Technician: AKDate: 10/8/2019

Elapsed Time (min)	Particulate Sampling Data							Flue Gas Data		
	Gas Meter (ft <sup>3</sup> )	Sample Rate (cfm)	Orifice dH (in H <sub>2</sub> O)	Meter Temp (°F)	Meter Vacuum (in Hg)	Pro. Rate (%)	Filter (°F)	Flue Draft (in H <sub>2</sub> O)	CO <sub>2</sub> (%)	CO (%)
128	18.597	0.147	2.11	103	-0.45	101	86	0.050	11.03	0.34
129	18.744	0.147	2.11	103	-0.7	101	86	0.040	11.27	0.36
130	18.890	0.146	2.09	103	-2.67	100	86	0.050	10.89	0.40
131	19.035	0.145	2.07	103	-2.23	99	86	0.060	11.03	0.42
132	19.181	0.147	2.10	103	0	100	86	0.070	10.68	0.57
133	19.327	0.146	2.09	103	-1.36	100	86	0.050	10.30	0.60
134	19.473	0.146	2.08	103	-2.62	100	86	0.050	10.10	0.56
135	19.619	0.146	2.09	103	-0.12	100	86	0.050	10.02	0.53
136	19.764	0.146	2.08	103	-0.01	99	86	0.070	10.10	0.58
137	19.909	0.145	2.07	103	-2.49	99	86	0.070	10.00	0.49
138	20.055	0.146	2.08	103	0	99	86	0.060	10.18	0.56
139	20.201	0.146	2.08	103	-0.58	99	86	0.060	9.98	0.48
140	20.347	0.147	2.10	103	-2.46	100	86	0.060	9.95	0.56
141	20.493	0.146	2.09	103	-2.02	100	86	0.050	9.95	0.54
142	20.639	0.146	2.09	103	-0.87	100	86	0.050	10.15	0.48
143	20.785	0.146	2.08	103	-0.59	105	86	0.050	9.88	0.47
144	20.931	0.146	2.09	103	-0.05	100	86	0.070	9.94	0.50
145	21.076	0.146	2.08	103	-0.06	99	86	0.060	9.84	0.56
146	21.223	0.147	2.10	103	-1.46	100	86	0.040	9.68	0.57
147	21.369	0.147	2.10	103	-2.31	100	86	0.060	9.61	0.59
148	21.515	0.146	2.09	103	-2.57	100	86	0.060	9.09	0.51
149	21.662	0.147	2.10	103	0	100	85	0.040	8.87	0.66
150	21.808	0.146	2.08	103	-0.02	99	85	0.040	8.85	0.60
151	21.954	0.146	2.09	103	-1.49	99	85	0.040	8.92	0.58
152	22.099	0.146	2.08	103	-0.11	99	85	0.040	8.30	0.70
153	22.246	0.147	2.10	103	-1.72	100	86	0.040	8.08	0.76
154	22.392	0.147	2.10	103	-0.52	100	86	0.040	7.99	0.91
155	22.537	0.145	2.07	103	-2.51	99	86	0.040	8.17	0.92
156	22.683	0.146	2.09	103	-2.14	99	86	0.060	8.29	0.95
157	22.829	0.146	2.09	102	-1.2	100	86	0.030	8.13	0.99
158	22.975	0.146	2.09	102	-0.99	100	85	0.040	8.09	0.99
159	23.122	0.147	2.10	102	0	100	85	0.050	7.90	1.08



## BOX B TEST DATA - ASTM E3053 / ASTM E2515

Client: New Buck CorporationJob #: 19-519Model: 74Tracking #: 0042Run #: 2Technician: AKDate: 10/8/2019

Elapsed Time (min)	Particulate Sampling Data							Flue Gas Data		
	Gas Meter (ft <sup>3</sup> )	Sample Rate (cfm)	Orifice dH (in H <sub>2</sub> O)	Meter Temp (°F)	Meter Vacuum (in Hg)	Pro. Rate (%)	Filter (°F)	Flue Draft (in H <sub>2</sub> O)	CO <sub>2</sub> (%)	CO (%)
160	23.269	0.147	2.11	102	-2.67	100	86	0.050	7.86	1.05
161	23.416	0.147	2.10	102	-0.72	100	86	0.040	7.53	1.12
162	23.562	0.147	2.10	102	-2.15	100	86	0.040	7.64	1.11
163	23.708	0.146	2.08	102	-1.2	99	86	-0.050	7.78	1.12
164	23.853	0.146	2.08	102	-2.32	99	86	-0.040	8.08	1.07
165	24.000	0.147	2.10	102	-0.07	100	86	-0.050	7.72	1.14
166	24.146	0.146	2.09	102	-2.63	100	86	-0.050	7.76	1.16
167	24.292	0.147	2.10	102	-1.5	100	85	-0.070	7.90	1.17
168	24.439	0.147	2.10	102	-0.08	100	85	-0.040	8.06	1.15
169	24.585	0.147	2.10	102	-1.32	100	86	-0.030	7.85	1.20
170	24.732	0.146	2.09	102	-0.07	99	86	-0.060	7.73	1.14
171	24.878	0.147	2.10	102	-2.18	100	86	-0.030	7.84	1.12
172	25.024	0.146	2.08	102	-2.51	99	86	-0.040	7.77	1.14
173	25.169	0.146	2.08	102	-2.88	99	86	-0.050	7.94	1.18
174	25.315	0.146	2.09	102	0	99	86	-0.040	7.95	1.15
175	25.461	0.146	2.09	102	-0.04	99	85	-0.070	7.71	1.17
176	25.608	0.147	2.10	102	-2.78	100	85	-0.050	7.98	1.14
177	25.753	0.146	2.08	102	-1.2	99	85	-0.050	7.93	1.17
178	25.899	0.146	2.08	102	-1.09	99	86	-0.040	8.03	0.94
179	26.045	0.146	2.09	102	-0.07	99	86	-0.050	7.93	1.10
180	26.191	0.146	2.09	102	-0.58	99	86	-0.010	8.05	1.07
181	26.337	0.146	2.08	102	-0.25	99	86	-0.060	7.78	1.09
182	26.482	0.146	2.08	102	-1.7	99	86	-0.050	8.30	1.04
183	26.629	0.147	2.10	101	-2	100	86	-0.050	8.27	1.01
184	26.774	0.145	2.07	101	-1.81	99	85	-0.040	7.99	1.07
185	26.919	0.146	2.08	101	-0.04	99	85	-0.040	8.00	1.03
186	27.065	0.146	2.09	101	-2.64	100	85	-0.040	8.22	1.02
187	27.212	0.147	2.10	101	-0.94	100	86	-0.040	8.04	1.04
188	27.357	0.145	2.07	101	-2.35	99	86	-0.060	7.93	1.03
189	27.503	0.146	2.09	101	-0.56	100	86	-0.040	7.54	1.06
190	27.648	0.146	2.08	101	-0.16	99	86	-0.060	7.69	1.12
191	27.794	0.146	2.08	101	-0.78	99	86	-0.050	7.57	1.09

# BOX B TEST DATA - ASTM E3053 / ASTM E2515

Client: New Buck Corporation

Job #: 19-519

Model: 74

Tracking #: 0042

Run #: 2

Technician: AK

Date: 10/8/2019

Elapsed Time (min)	Particulate Sampling Data							Flue Gas Data		
	Gas Meter (ft <sup>3</sup> )	Sample Rate (cfm)	Orifice dH (in H <sub>2</sub> O)	Meter Temp (°F)	Meter Vacuum (in Hg)	Pro. Rate (%)	Filter (°F)	Flue Draft (in H <sub>2</sub> O)	CO <sub>2</sub> (%)	CO (%)
192	27.939	0.145	2.07	101	-1.66	99	86	-0.070	7.60	1.03
193	28.086	0.147	2.10	101	-0.47	100	86	-0.050	7.63	1.12
194	28.232	0.147	2.10	101	-1.69	100	85	-0.050	7.67	1.01
195	28.377	0.145	2.07	101	-1.14	99	85	-0.040	7.10	1.43
196	28.522	0.145	2.06	101	-2	99	85	-0.040	7.04	1.50
197	28.667	0.146	2.08	101	-1.8	99	86	-0.060	7.11	1.45
198	28.812	0.145	2.07	101	-0.1	99	86	-0.040	7.14	1.51
199	28.958	0.146	2.09	101	-2.79	100	86	-0.040	7.20	1.46
200	29.104	0.146	2.09	101	-0.43	100	85	-0.050	6.96	1.41
201	29.250	0.146	2.08	101	-1.29	99	85	-0.040	7.24	1.40
202	29.395	0.146	2.08	101	0	99	85	-0.040	6.98	1.46
203	29.541	0.145	2.07	101	-0.05	99	85	-0.030	6.97	1.44
204	29.686	0.145	2.07	100	-0.07	99	85	-0.010	6.70	1.34
205	29.831	0.146	2.08	100	-0.25	99	85	-0.040	7.08	1.43
206	29.977	0.146	2.08	100	-2.58	99	85	-0.040	6.93	1.37
207	30.122	0.145	2.07	100	-0.85	99	85	-0.060	6.65	1.43
208	30.266	0.144	2.05	100	-2.56	98	85	-0.040	6.86	1.36
209	30.410	0.145	2.06	100	-1.16	99	85	-0.040	7.01	1.37
210	30.556	0.146	2.08	100	-0.12	99	85	-0.030	6.73	1.36
211	30.700	0.145	2.06	100	-1.66	99	85	-0.040	6.66	1.31
212	30.845	0.145	2.07	100	-1.12	99	85	-0.070	6.62	1.24
213	30.990	0.145	2.07	100	-2.54	99	85	-0.040	6.68	1.19
214	31.135	0.145	2.07	100	0	99	85	-0.020	6.58	1.17
215	31.281	0.145	2.07	100	-1.5	99	85	-0.050	6.58	1.10
216	31.426	0.145	2.07	100	-1.07	99	85	-0.040	6.90	1.04
217	31.572	0.146	2.09	100	-2.35	100	85	-0.040	6.54	1.03
218	31.717	0.145	2.07	100	-0.74	99	85	-0.040	6.27	1.06
219	31.861	0.145	2.06	100	-2.65	99	85	-0.040	6.49	1.07
220	32.007	0.146	2.08	100	-1.25	99	85	-0.020	6.35	1.00
221	32.151	0.145	2.06	101	-0.79	99	85	-0.040	6.52	1.08
222	32.296	0.145	2.06	101	-0.1	98	85	-0.030	6.35	1.05
223	32.441	0.146	2.08	101	-0.12	99	85	-0.050	6.52	1.03

## BOX B TEST DATA - ASTM E3053 / ASTM E2515

Client: New Buck Corporation  
 Model: 74  
 Run #: 2

Job #: 19-519  
 Tracking #: 0042  
 Technician: AK  
 Date: 10/8/2019

Elapsed Time (min)	Particulate Sampling Data							Flue Gas Data		
	Gas Meter (ft <sup>3</sup> )	Sample Rate (cfm)	Orifice dH (in H <sub>2</sub> O)	Meter Temp (°F)	Meter Vacuum (in Hg)	Pro. Rate (%)	Filter (°F)	Flue Draft (in H <sub>2</sub> O)	CO <sub>2</sub> (%)	CO (%)
224	32.586	0.145	2.07	101	-2.58	99	85	-0.020	6.44	1.07
225	32.732	0.146	2.08	101	-2.55	99	85	-0.030	6.43	1.02
226	32.877	0.146	2.08	101	0	99	85	-0.040	6.27	1.02
227	33.023	0.145	2.07	101	-1.95	99	85	-0.050	6.12	1.02
228	33.167	0.145	2.06	101	-1.6	98	85	-0.030	6.48	1.06
229	33.314	0.147	2.10	101	-0.18	100	85	-0.040	6.34	1.03
230	33.459	0.145	2.07	101	-2.08	99	85	-0.050	6.49	1.08
231	33.604	0.145	2.07	101	-0.19	99	85	-0.040	6.47	1.09
232	33.749	0.145	2.07	101	-0.3	99	85	-0.010	6.65	1.06
233	33.893	0.145	2.06	101	-2.08	98	85	-0.040	6.33	1.07
234	34.038	0.145	2.07	101	-2.47	99	85	-0.020	6.43	1.03
235	34.183	0.145	2.07	101	-0.21	99	85	-0.040	6.18	1.00
236	34.329	0.146	2.08	101	-0.6	99	85	-0.040	5.95	1.03
237	34.474	0.145	2.07	101	-2.66	99	85	-0.030	6.04	1.01
238	34.620	0.146	2.08	101	-2.72	99	85	-0.040	6.08	0.99
239	34.766	0.146	2.09	101	-0.05	99	85	-0.040	5.81	1.01
240	34.911	0.146	2.08	101	-2.6	99	85	-0.030	6.14	0.98
241	35.056	0.145	2.07	101	-2.76	99	85	-0.050	5.79	0.99
242	35.201	0.145	2.06	101	-2.69	98	85	-0.040	5.82	1.02
243	35.346	0.145	2.07	101	-2.44	99	85	-0.030	5.93	0.99
244	35.491	0.146	2.08	101	-2.3	99	85	-0.040	5.72	1.00
245	35.636	0.145	2.06	101	-1.52	98	85	-0.040	6.05	0.97
246	35.781	0.146	2.08	101	-0.07	99	85	-0.050	5.63	0.99
247	35.926	0.145	2.07	101	-1.25	99	85	-0.020	5.97	0.90
248	36.072	0.146	2.08	101	-0.49	99	85	-0.040	5.64	1.02
249	36.216	0.145	2.06	101	-0.42	98	85	-0.040	5.82	1.00
250	36.363	0.146	2.09	100	-1.21	99	85	-0.040	5.69	0.98
251	36.508	0.145	2.07	100	-0.62	94	85	-0.040	5.68	0.96
252	36.652	0.145	2.06	100	-2.63	98	85	-0.020	5.89	1.01
253	36.798	0.146	2.08	100	-2.64	99	85	-0.040	5.74	0.94
254	36.943	0.146	2.08	100	-2.49	99	85	-0.010	5.75	0.97
255	37.088	0.145	2.06	100	-1.66	98	85	-0.030	5.70	0.92

# BOX B TEST DATA - ASTM E3053 / ASTM E2515

Client: New Buck Corporation

Job #: 19-519

Model: 74

Tracking #: 0042

Run #: 2

Technician: AK

Date: 10/8/2019

Elapsed Time (min)	Particulate Sampling Data							Flue Gas Data		
	Gas Meter (ft <sup>3</sup> )	Sample Rate (cfm)	Orifice dH (in H <sub>2</sub> O)	Meter Temp (°F)	Meter Vacuum (in Hg)	Pro. Rate (%)	Filter (°F)	Flue Draft (in H <sub>2</sub> O)	CO <sub>2</sub> (%)	CO (%)
256	37.232	0.145	2.06	100	-1.61	98	84	-0.030	5.81	0.93
257	37.378	0.146	2.08	100	-2.67	99	85	-0.010	5.68	0.99
258	37.523	0.145	2.07	100	-1.06	99	85	-0.030	5.71	0.98
259	37.668	0.145	2.07	100	-2.52	99	85	-0.040	5.55	1.01
260	37.814	0.146	2.09	100	-2.64	99	85	-0.060	5.45	0.97
261	37.959	0.145	2.07	100	-0.56	99	85	-0.040	5.71	0.97
262	38.105	0.146	2.08	100	-2.69	99	85	-0.030	5.62	0.99
263	38.249	0.144	2.05	100	-0.68	98	85	-0.020	5.55	0.98
264	38.394	0.145	2.07	100	0	99	85	-0.030	5.83	1.01
265	38.539	0.145	2.07	100	-2.83	99	84	-0.030	5.81	0.99
266	38.684	0.146	2.08	100	-2.6	99	84	-0.030	6.16	1.01
267	38.830	0.146	2.08	100	-0.16	99	85	-0.040	5.97	0.99
268	38.975	0.146	2.08	100	-2.18	99	85	-0.030	5.89	0.99
269	39.120	0.145	2.07	100	-2.7	99	85	-0.040	5.86	1.02
270	39.266	0.146	2.09	100	-0.26	99	85	-0.020	5.82	1.00
271	39.411	0.145	2.06	100	-0.2	98	85	-0.020	5.56	1.00
272	39.555	0.145	2.06	100	-0.6	98	85	-0.030	5.75	0.97
273	39.701	0.145	2.07	100	-2.78	98	84	-0.020	5.44	0.95
274	39.847	0.146	2.09	100	-2.55	99	84	-0.050	5.61	0.95
275	39.992	0.146	2.08	100	-0.05	99	84	-0.030	5.48	1.03
276	40.138	0.146	2.08	100	-2.23	99	85	-0.020	5.51	1.01
277	40.283	0.146	2.08	100	-1.64	99	85	-0.020	5.52	0.97
278	40.429	0.146	2.09	100	-2.68	99	85	-0.050	5.45	0.93
279	40.573	0.144	2.05	100	-2.63	98	85	-0.030	5.29	0.92
280	40.719	0.146	2.08	100	-1	99	85	-0.040	5.36	0.93
281	40.864	0.146	2.08	100	-1.73	99	84	-0.040	5.29	0.93
282	41.010	0.146	2.08	100	-2.74	99	84	-0.020	5.25	0.96
283	41.155	0.146	2.08	100	-0.22	99	84	-0.030	5.38	0.97
284	41.301	0.146	2.08	100	-2.21	99	84	-0.040	5.41	0.92
285	41.446	0.145	2.06	100	-2.68	98	85	-0.020	5.41	0.92
286	41.591	0.146	2.08	100	-2.01	99	85	-0.020	5.36	1.00
287	41.737	0.146	2.08	100	-0.1	99	85	-0.040	5.22	0.99

## BOX B TEST DATA - ASTM E3053 / ASTM E2515

Client: New Buck CorporationJob #: 19-519Model: 74Tracking #: 0042Run #: 2Technician: AKDate: 10/8/2019

Elapsed Time (min)	Particulate Sampling Data							Flue Gas Data		
	Gas Meter (ft <sup>3</sup> )	Sample Rate (cfm)	Orifice dH (in H <sub>2</sub> O)	Meter Temp (°F)	Meter Vacuum (in Hg)	Pro. Rate (%)	Filter (°F)	Flue Draft (in H <sub>2</sub> O)	CO <sub>2</sub> (%)	CO (%)
288	41.882	0.146	2.08	100	-1.69	99	85	-0.020	5.22	0.96
289	42.028	0.146	2.08	100	-2.66	99	85	-0.050	5.24	0.95
290	42.174	0.147	2.10	100	-1.55	99	84	-0.040	5.18	0.98
291	42.320	0.146	2.08	99	-2.53	99	84	-0.040	5.37	0.98
292	42.466	0.146	2.09	99	-2.08	99	84	-0.040	5.19	0.98
293	42.612	0.147	2.10	99	-2.06	100	84	-0.040	5.21	1.03
294	42.758	0.146	2.08	99	-2.74	99	85	-0.030	5.52	1.01
295	42.905	0.147	2.10	99	0	100	85	-0.030	5.47	1.08
296	43.050	0.146	2.08	99	-2.37	99	85	-0.030	5.51	1.05
297	43.196	0.146	2.08	99	-0.43	99	85	-0.030	5.08	1.06
298	43.342	0.146	2.09	99	-0.95	99	85	-0.050	5.41	1.02
299	43.487	0.146	2.08	99	-2.74	99	84	-0.030	5.47	1.05
300	43.633	0.146	2.08	99	-2.64	99	84	-0.040	5.14	1.01
301	43.778	0.145	2.07	99	-1.49	99	84	-0.030	5.24	1.01
302	43.924	0.147	2.10	99	-2.06	100	84	-0.030	5.57	1.01
303	44.069	0.145	2.07	99	-0.96	98	85	-0.030	5.47	1.01
304	44.215	0.146	2.09	99	-1.71	99	85	-0.010	5.38	1.02
305	44.361	0.146	2.09	99	-2.57	99	85	-0.020	5.12	1.07
306	44.507	0.146	2.08	99	-2.44	99	85	-0.030	5.49	1.04
307	44.653	0.146	2.09	99	-1.8	99	84	-0.040	5.42	1.02
308	44.799	0.146	2.09	99	-2.75	99	84	-0.050	5.16	1.05
309	44.946	0.147	2.10	99	-2.66	99	84	-0.050	5.39	1.01
310	45.092	0.147	2.10	99	-2.78	99	84	-0.020	5.30	1.00
311	45.238	0.146	2.09	99	-0.11	99	84	-0.050	5.36	1.09
312	45.384	0.146	2.09	99	-0.02	99	84	-0.040	5.34	1.05
313	45.529	0.145	2.06	99	-2.62	98	85	-0.030	5.24	1.12
314	45.675	0.146	2.09	99	-1.26	99	85	-0.040	5.11	1.07
315	45.821	0.146	2.09	99	-0.16	99	84	-0.040	5.34	1.03
316	45.967	0.146	2.09	99	-0.78	99	84	-0.040	5.37	1.01
317	46.113	0.146	2.08	99	-1.99	99	84	-0.020	5.55	1.04
318	46.259	0.146	2.09	99	-0.11	99	84	-0.020	5.54	1.01
319	46.406	0.147	2.11	99	-0.23	100	84	-0.040	5.39	1.09

# BOX B TEST DATA - ASTM E3053 / ASTM E2515

Client: New Buck Corporation

Job #: 19-519

Model: 74

Tracking #: 0042

Run #: 2

Technician: AK

Date: 10/8/2019

Elapsed Time (min)	Particulate Sampling Data							Flue Gas Data		
	Gas Meter (ft <sup>3</sup> )	Sample Rate (cfm)	Orifice dH (in H <sub>2</sub> O)	Meter Temp (°F)	Meter Vacuum (in Hg)	Pro. Rate (%)	Filter (°F)	Flue Draft (in H <sub>2</sub> O)	CO <sub>2</sub> (%)	CO (%)
320	46.551	0.146	2.08	98	-0.99	99	84	-0.020	5.31	1.01
321	46.698	0.147	2.10	98	-0.18	100	85	-0.030	5.23	1.04
322	46.844	0.147	2.10	98	-2.56	100	85	-0.030	5.37	1.06
323	46.990	0.146	2.09	98	-2.73	99	85	-0.040	5.36	1.02
324	47.137	0.147	2.11	98	-0.01	100	84	-0.040	5.23	1.00
325	47.284	0.147	2.10	98	0	100	84	-0.020	5.18	1.01
326	47.430	0.146	2.09	98	-1.67	99	84	-0.010	5.34	1.04
327	47.576	0.147	2.10	98	-0.36	100	84	-0.040	5.07	1.03
328	47.723	0.147	2.10	98	-2.43	100	84	-0.040	5.14	1.07
329	47.869	0.146	2.08	98	-2.63	99	84	-0.040	5.10	1.03
330	48.016	0.147	2.11	98	-0.52	100	85	-0.020	5.13	1.05
331	48.161	0.145	2.07	98	-0.34	99	85	-0.040	5.09	1.02
332	48.306	0.146	2.08	98	-1.59	99	85	-0.030	5.30	1.01
333	48.452	0.146	2.08	98	-2.04	99	84	-0.040	4.93	1.05
334	48.598	0.147	2.10	98	-2.48	99	84	-0.020	5.20	0.97
335	48.745	0.147	2.10	98	-1.01	100	84	-0.040	5.03	1.01
336	48.891	0.146	2.09	98	-2.29	99	84	-0.040	4.94	1.03
337	49.037	0.146	2.09	98	-0.52	99	84	-0.030	4.99	0.98
338	49.183	0.147	2.10	98	-1.89	100	84	-0.040	4.85	1.00
339	49.329	0.146	2.08	98	-2.7	99	85	-0.040	4.85	0.98
340	49.474	0.145	2.07	98	-0.35	99	85	-0.040	4.81	1.01
341	49.621	0.147	2.11	98	-2.49	100	85	-0.030	4.77	1.03
342	49.767	0.146	2.09	98	-0.56	99	84	-0.040	5.01	1.00
343	49.914	0.147	2.10	98	-2.53	100	84	-0.040	4.78	1.00
344	50.060	0.146	2.09	98	-0.1	99	84	-0.040	4.73	1.02
345	50.206	0.146	2.09	98	-0.08	99	84	-0.030	4.67	1.00
346	50.352	0.146	2.09	98	-0.6	99	84	-0.020	4.70	0.96
347	50.498	0.147	2.10	98	-2.5	100	84	-0.020	4.84	1.03
348	50.644	0.146	2.09	98	-0.12	99	85	-0.020	4.95	0.93
349	50.791	0.147	2.10	98	-2.38	100	85	-0.030	4.62	0.95
350	50.937	0.146	2.09	98	-0.5	99	85	-0.020	4.56	0.94
351	51.083	0.146	2.09	98	-0.19	99	85	-0.050	4.64	0.95

## BOX B TEST DATA - ASTM E3053 / ASTM E2515

Client: New Buck Corporation  
 Model: 74  
 Run #: 2

Job #: 19-519  
 Tracking #: 0042  
 Technician: AK  
 Date: 10/8/2019

Elapsed Time (min)	Particulate Sampling Data							Flue Gas Data		
	Gas Meter (ft <sup>3</sup> )	Sample Rate (cfm)	Orifice dH (in H <sub>2</sub> O)	Meter Temp (°F)	Meter Vacuum (in Hg)	Pro. Rate (%)	Filter (°F)	Flue Draft (in H <sub>2</sub> O)	CO <sub>2</sub> (%)	CO (%)
352	51.229	0.146	2.08	98	-0.05	99	84	-0.030	4.85	0.89
353	51.375	0.146	2.09	97	-1.42	100	84	-0.040	4.65	0.91
354	51.520	0.146	2.08	97	-1.28	99	84	-0.020	4.65	0.94
355	51.666	0.146	2.09	97	-2.56	100	84	-0.020	4.62	0.91
356	51.812	0.146	2.09	97	-2.44	100	85	-0.040	4.68	0.94
357	51.958	0.146	2.09	97	-2.07	100	85	-0.030	4.92	0.88
358	52.104	0.146	2.09	97	-2.61	100	85	-0.040	4.54	0.91
359	52.251	0.147	2.10	97	0	100	85	-0.020	4.51	0.90
360	52.397	0.146	2.08	97	-1.71	99	84	-0.040	4.68	0.95
361	52.543	0.146	2.09	97	-2.43	100	84	-0.050	4.61	0.96
362	52.688	0.146	2.08	97	-2.73	99	84	-0.010	4.49	0.97
363	52.834	0.146	2.09	97	-1.88	100	84	-0.050	4.80	0.92
364	52.981	0.147	2.10	97	-2.73	100	84	-0.030	4.78	1.00
365	53.126	0.146	2.08	97	-2.68	99	85	-0.040	4.72	0.97
366	53.272	0.146	2.08	97	-2.77	99	85	-0.030	4.52	0.95
367	53.418	0.146	2.09	97	-0.78	100	85	-0.020	4.72	0.97
368	53.565	0.147	2.11	97	-0.89	100	85	-0.030	4.86	0.97
369	53.711	0.146	2.09	97	-0.18	100	85	-0.030	4.77	0.92
370	53.857	0.147	2.10	97	-2.11	100	84	-0.050	4.72	0.93
371	54.004	0.146	2.09	97	-2.72	100	84	-0.010	4.80	1.04
372	54.149	0.145	2.07	97	-2.6	99	84	-0.030	4.49	1.02
373	54.295	0.146	2.09	97	-2.02	100	84	-0.040	4.73	0.96
374	54.441	0.147	2.10	97	-2.42	100	85	-0.030	4.59	1.01
375	54.587	0.146	2.09	97	-1.2	100	85	-0.030	4.69	1.00
376	54.733	0.146	2.08	97	-0.26	99	85	-0.040	4.73	0.99
377	54.878	0.146	2.08	97	-1.89	99	85	-0.040	4.75	1.02
378	55.025	0.147	2.11	97	0	100	84	-0.030	4.84	1.03
379	55.170	0.145	2.07	97	-2.23	99	84	-0.030	4.65	1.02
380	55.316	0.146	2.09	97	-0.1	100	84	-0.010	4.77	0.99
381	55.462	0.146	2.09	97	-2.63	100	84	-0.010	4.82	0.96
382	55.609	0.146	2.09	97	-0.02	100	85	-0.040	4.77	1.04
383	55.755	0.147	2.10	97	-0.25	100	85	-0.020	4.72	1.04

# BOX B TEST DATA - ASTM E3053 / ASTM E2515

Client: New Buck Corporation

Job #: 19-519

Model: 74

Tracking #: 0042

Run #: 2

Technician: AK

Date: 10/8/2019

Elapsed Time (min)	Particulate Sampling Data							Flue Gas Data		
	Gas Meter (ft <sup>3</sup> )	Sample Rate (cfm)	Orifice dH (in H <sub>2</sub> O)	Meter Temp (°F)	Meter Vacuum (in Hg)	Pro. Rate (%)	Filter (°F)	Flue Draft (in H <sub>2</sub> O)	CO <sub>2</sub> (%)	CO (%)
384	55.901	0.146	2.08	97	-0.26	99	85	-0.030	4.67	1.06
385	56.048	0.147	2.11	97	-2.53	100	85	-0.030	4.67	1.02
386	56.195	0.147	2.11	97	-1.85	100	85	-0.020	4.69	1.00
387	56.340	0.145	2.07	97	-0.65	99	84	-0.010	4.73	1.02
388	56.485	0.146	2.08	97	-2.8	99	84	-0.030	4.77	1.03
389	56.631	0.146	2.09	97	-2.65	100	84	-0.020	4.83	1.04
390	56.777	0.146	2.09	97	-1.7	100	84	-0.040	4.67	1.02
391	56.924	0.147	2.11	97	-1.44	100	85	-0.030	4.66	1.10
392	57.071	0.146	2.09	97	-2.71	100	85	-0.020	4.60	0.99
393	57.217	0.146	2.09	97	-0.04	100	85	-0.040	4.62	1.07
394	57.363	0.146	2.09	97	-2.56	100	85	-0.030	4.68	0.98
395	57.509	0.147	2.10	97	-2.15	100	85	-0.020	4.40	1.01
396	57.656	0.147	2.10	97	-1.49	100	84	-0.030	4.74	1.09
397	57.803	0.147	2.11	97	-2.73	100	84	-0.030	4.81	1.14
398	57.949	0.146	2.09	97	-1.16	100	84	-0.030	4.78	1.12
399	58.095	0.147	2.10	97	-0.57	100	84	-0.020	4.81	1.18
400	58.242	0.147	2.10	97	-1.18	100	85	-0.010	4.86	1.09
401	58.388	0.146	2.09	97	0	100	85	-0.010	4.95	1.10
402	58.534	0.147	2.10	97	-0.04	100	85	-0.020	4.68	1.14
403	58.681	0.147	2.10	97	-0.84	100	85	-0.020	4.83	1.07
404	58.827	0.146	2.09	97	-0.25	100	84	-0.020	4.90	1.09
405	58.973	0.146	2.08	97	-0.19	99	84	-0.040	5.01	1.05
406	59.119	0.147	2.10	97	0	100	84	-0.030	4.78	1.03
407	59.266	0.147	2.11	97	-2.38	100	84	-0.030	4.93	1.03
408	59.413	0.147	2.11	97	0	100	84	-0.030	4.66	1.08
409	59.559	0.146	2.09	97	0	100	85	-0.010	4.69	1.04
410	59.705	0.146	2.09	97	-0.97	100	85	-0.040	4.75	1.08
411	59.851	0.146	2.09	97	-2.42	100	85	-0.030	4.88	1.00
412	59.998	0.147	2.11	97	-2.31	100	85	0.000	4.74	1.03
413	60.144	0.146	2.08	97	-0.65	99	84	-0.040	4.83	0.96
414	60.291	0.147	2.10	97	-0.01	100	84	-0.020	4.74	0.99
415	60.436	0.146	2.08	97	-0.11	99	84	-0.030	4.57	1.05



## BOX B TEST DATA - ASTM E3053 / ASTM E2515

Client: New Buck CorporationJob #: 19-519Model: 74Tracking #: 0042Run #: 2Technician: AKDate: 10/8/2019

Elapsed Time (min)	Particulate Sampling Data							Flue Gas Data		
	Gas Meter (ft <sup>3</sup> )	Sample Rate (cfm)	Orifice dH (in H <sub>2</sub> O)	Meter Temp (°F)	Meter Vacuum (in Hg)	Pro. Rate (%)	Filter (°F)	Flue Draft (in H <sub>2</sub> O)	CO <sub>2</sub> (%)	CO (%)
416	60.582	0.146	2.09	97	-2.55	100	84	-0.020	4.73	1.04
417	60.728	0.146	2.09	97	-0.35	100	84	-0.030	4.59	1.01
418	60.875	0.147	2.10	97	-2.61	100	84	-0.040	4.63	1.02
419	61.022	0.147	2.11	97	-0.35	100	85	-0.030	4.50	0.98
420	61.168	0.147	2.10	97	-2.72	100	85	-0.020	4.63	0.99
421	61.314	0.146	2.09	97	-0.16	100	85	-0.020	4.88	0.97
422	61.461	0.147	2.11	97	-0.06	100	84	-0.020	4.70	1.00
423	61.607	0.146	2.08	97	-2.7	99	84	-0.020	4.66	0.96
424	61.753	0.146	2.08	97	-0.54	99	84	0.000	4.69	0.92
425	61.899	0.147	2.10	96	-0.78	100	84	-0.010	4.94	0.93
426	62.046	0.147	2.11	96	-2.67	100	84	-0.020	4.79	0.90
427	62.192	0.146	2.08	96	-0.49	99	85	-0.040	4.59	0.95
428	62.338	0.147	2.10	96	-0.8	100	85	-0.020	4.79	0.93
429	62.485	0.147	2.10	96	-2.52	100	85	-0.010	4.73	0.92
430	62.631	0.147	2.10	96	-2.36	100	84	-0.030	4.65	0.88
431	62.777	0.146	2.09	96	-2.58	100	84	-0.040	4.43	0.94
432	62.923	0.146	2.09	96	-2.43	100	84	-0.030	4.68	0.88
433	63.070	0.147	2.10	96	-2.78	100	84	-0.030	4.68	0.89
434	63.217	0.147	2.11	96	-0.75	100	84	-0.030	4.57	0.83
435	63.364	0.147	2.10	96	-2.63	100	84	-0.020	4.79	0.91
436	63.510	0.146	2.09	96	-1.68	100	85	-0.040	4.34	0.95
437	63.656	0.147	2.10	96	-0.09	100	85	-0.030	4.60	0.92
438	63.803	0.147	2.11	96	-2.51	100	85	-0.050	4.72	0.95
439	63.949	0.146	2.08	96	-0.15	99	84	0.000	4.77	0.97
440	64.095	0.146	2.09	96	-1.03	100	84	-0.030	4.51	0.97
441	64.241	0.146	2.09	96	-2.69	100	84	-0.020	4.46	0.98
442	64.387	0.146	2.09	96	-0.14	100	84	-0.030	4.52	0.95
443	64.532	0.146	2.08	96	-0.1	99	84	-0.030	4.67	1.01
444	64.679	0.147	2.10	96	-2.57	100	84	-0.030	4.63	1.00
445	64.825	0.146	2.09	96	-1.26	100	85	-0.030	4.43	1.02
446	64.971	0.146	2.09	96	-2.56	100	85	-0.020	4.39	1.01
447	65.119	0.148	2.12	96	-1.07	101	85	-0.030	4.59	1.07

## BOX B TEST DATA - ASTM E3053 / ASTM E2515

Client: New Buck CorporationJob #: 19-519Model: 74Tracking #: 0042Run #: 2Technician: AKDate: 10/8/2019

Elapsed Time (min)	Particulate Sampling Data							Flue Gas Data		
	Gas Meter (ft <sup>3</sup> )	Sample Rate (cfm)	Orifice dH (in H <sub>2</sub> O)	Meter Temp (°F)	Meter Vacuum (in Hg)	Pro. Rate (%)	Filter (°F)	Flue Draft (in H <sub>2</sub> O)	CO <sub>2</sub> (%)	CO (%)
448	65.266	0.147	2.11	96	-1.8	100	84	-0.050	4.59	0.97
449	65.412	0.146	2.09	96	-2.5	100	84	-0.010	4.66	0.97
450	65.557	0.146	2.08	96	-2.77	99	84	-0.010	4.34	1.02
451	65.704	0.147	2.10	96	-2.03	100	84	-0.010	4.53	0.98
452	65.850	0.146	2.09	96	-1.77	100	84	-0.030	4.41	0.94
453	65.996	0.147	2.10	96	-0.08	100	84	-0.020	4.73	0.93
454	66.143	0.147	2.11	96	-0.79	100	85	-0.010	4.45	0.97
455	66.290	0.147	2.10	96	-1.51	100	85	-0.030	4.32	0.94
456	66.436	0.146	2.09	96	-0.08	100	85	-0.020	4.67	0.92
457	66.583	0.147	2.10	96	-0.97	100	84	-0.030	4.52	0.92
458	66.730	0.147	2.11	96	0	100	84	-0.020	4.38	0.90
459	66.877	0.147	2.11	96	-1.57	100	84	-0.020	4.43	1.00
460	67.023	0.147	2.10	96	0	100	84	-0.030	4.22	0.96
461	67.170	0.147	2.11	96	-2.57	100	84	-0.030	4.25	0.98
462	67.317	0.147	2.11	96	-2.46	100	84	-0.010	4.42	0.87
463	67.464	0.147	2.10	96	-0.15	100	85	-0.020	4.26	0.91
464	67.609	0.146	2.08	96	-0.01	99	85	-0.020	4.22	0.91
465	67.755	0.146	2.08	96	-0.25	99	84	-0.030	4.42	0.91
466	67.902	0.147	2.11	96	-0.41	100	84	-0.020	4.32	0.87
467	68.049	0.147	2.10	96	-2.32	100	84	-0.020	4.22	0.92
468	68.195	0.147	2.10	96	-0.13	100	84	-0.040	4.21	0.92
469	68.342	0.147	2.11	96	-1.52	100	84	-0.020	4.23	0.95
470	68.489	0.147	2.10	96	-0.09	100	84	-0.030	4.40	0.84
471	68.636	0.147	2.11	96	-1.99	100	84	-0.040	4.24	0.95
472	68.783	0.147	2.11	96	-0.33	100	84	-0.030	4.29	0.91
473	68.929	0.146	2.09	96	-0.98	100	85	-0.030	4.16	0.88
474	69.076	0.147	2.11	96	-0.36	100	84	-0.030	4.19	0.91
475	69.222	0.147	2.10	96	-0.06	100	84	-0.020	4.42	0.92
476	69.369	0.147	2.10	96	-0.25	100	84	-0.020	4.42	0.86
477	69.516	0.147	2.10	96	-0.02	100	84	-0.030	4.37	0.87
478	69.663	0.147	2.11	96	-0.75	100	84	-0.030	4.51	0.89
479	69.809	0.147	2.10	96	-2.68	100	84	-0.020	4.39	0.90

# BOX B TEST DATA - ASTM E3053 / ASTM E2515

Client: New Buck Corporation

Job #: 19-519

Model: 74

Tracking #: 0042

Run #: 2

Technician: AK

Date: 10/8/2019

Elapsed Time (min)	Particulate Sampling Data							Flue Gas Data		
	Gas Meter (ft <sup>3</sup> )	Sample Rate (cfm)	Orifice dH (in H <sub>2</sub> O)	Meter Temp (°F)	Meter Vacuum (in Hg)	Pro. Rate (%)	Filter (°F)	Flue Draft (in H <sub>2</sub> O)	CO <sub>2</sub> (%)	CO (%)
480	69.955	0.146	2.08	96	-2.38	99	84	-0.020	4.20	0.95
481	70.099	0.144	2.05	96	-0.07	98	84	-0.030	4.05	0.99
482	70.243	0.145	2.06	96	-2.66	98	85	-0.020	4.12	0.97
483	70.387	0.144	2.05	96	-2.28	98	84	-0.020	4.13	0.99
484	70.531	0.144	2.04	96	-2.7	98	84	-0.020	4.13	0.98
485	70.675	0.145	2.06	96	-2.46	98	84	-0.040	4.07	0.94
486	70.820	0.145	2.07	95	0	99	84	-0.010	4.46	0.98
487	70.965	0.145	2.06	95	-2.49	99	84	-0.020	4.46	0.90
488	71.110	0.145	2.07	95	-2.69	99	84	-0.010	4.34	0.96
489	71.255	0.145	2.07	95	-2.65	99	84	-0.020	4.25	0.97
490	71.400	0.145	2.07	95	-1.24	99	84	-0.020	4.12	0.93
491	71.545	0.145	2.07	95	-2.67	99	84	-0.030	4.03	0.98
492	71.690	0.145	2.07	95	-1.65	99	84	-0.030	4.10	0.96
493	71.835	0.145	2.06	95	-0.35	98	84	-0.020	4.21	0.95
494	71.980	0.145	2.07	95	-1.57	99	84	-0.020	4.39	0.97
495	72.124	0.144	2.05	95	-2.2	98	84	-0.020	4.20	0.89
496	72.269	0.146	2.08	95	-2.61	99	84	-0.040	4.25	0.97
497	72.414	0.145	2.07	95	-0.24	99	84	-0.040	4.49	0.93
498	72.558	0.144	2.05	95	-2.66	98	84	-0.040	4.10	1.00
499	72.703	0.145	2.07	95	-0.7	99	84	-0.020	4.17	0.96
500	72.848	0.145	2.06	95	-0.12	98	84	-0.020	4.30	0.90
501	72.993	0.145	2.07	95	-1.14	99	84	-0.030	4.22	0.98
502	73.139	0.146	2.08	95	-0.33	99	84	-0.020	3.85	0.94
503	73.283	0.145	2.06	95	-2.52	98	84	-0.010	4.43	0.88
504	73.429	0.146	2.08	95	-2.54	99	84	-0.030	4.08	0.91
505	73.574	0.145	2.07	95	-0.09	99	84	0.000	4.06	0.91
506	73.719	0.145	2.07	95	-2.54	99	84	-0.030	4.13	0.95
507	73.864	0.145	2.07	95	-1.19	99	84	-0.030	4.09	0.89
508	74.009	0.145	2.07	95	-2.53	99	84	-0.030	4.10	0.90
509	74.153	0.145	2.06	95	-0.79	98	84	-0.030	3.79	0.94
510	74.298	0.145	2.07	95	-1.04	99	84	-0.020	3.88	0.94
511	74.443	0.145	2.07	95	-0.03	99	84	-0.030	3.93	0.98

# BOX B TEST DATA - ASTM E3053 / ASTM E2515

Client: New Buck Corporation

Job #: 19-519

Model: 74

Tracking #: 0042

Run #: 2

Technician: AK

Date: 10/8/2019

Elapsed Time (min)	Particulate Sampling Data							Flue Gas Data		
	Gas Meter (ft <sup>3</sup> )	Sample Rate (cfm)	Orifice dH (in H <sub>2</sub> O)	Meter Temp (°F)	Meter Vacuum (in Hg)	Pro. Rate (%)	Filter (°F)	Flue Draft (in H <sub>2</sub> O)	CO <sub>2</sub> (%)	CO (%)
512	74.588	0.145	2.06	95	-0.28	98	84	-0.030	3.94	0.94
513	74.732	0.144	2.04	95	-0.12	98	84	-0.020	4.02	0.89
514	74.877	0.145	2.07	95	-1.45	99	84	-0.040	3.77	0.93
515	75.021	0.144	2.05	95	-0.15	98	84	-0.030	3.82	0.95
516	75.165	0.145	2.06	95	-1.09	98	84	-0.020	3.45	0.91
517	75.310	0.145	2.06	95	-0.22	98	84	-0.020	3.92	0.87
518	75.455	0.145	2.07	95	-2.83	99	84	-0.020	3.80	0.91
519	75.600	0.145	2.07	95	-0.23	99	84	-0.020	3.85	0.83
520	75.744	0.145	2.06	95	-0.09	98	84	-0.030	3.73	0.86
521	75.889	0.145	2.06	95	-1.66	98	84	-0.020	3.58	0.88
522	76.034	0.146	2.08	94	0	99	84	-0.020	3.25	0.86
523	76.179	0.145	2.07	94	-2.52	99	83	-0.030	3.46	0.88
524	76.325	0.145	2.07	94	-0.19	99	84	-0.010	3.48	0.82
525	76.470	0.145	2.07	94	-2.65	99	84	-0.020	3.56	0.80
526	76.615	0.146	2.08	94	-0.32	99	84	-0.050	3.40	0.87
527	76.760	0.145	2.07	94	-1.66	99	84	-0.020	3.15	0.84
528	76.905	0.145	2.06	94	-2.66	98	84	-0.030	3.29	0.81
529	77.050	0.145	2.07	94	0	99	84	-0.020	3.21	0.81
530	77.195	0.145	2.07	94	-0.68	99	84	-0.020	3.28	0.86
531	77.339	0.145	2.06	94	-1.81	98	84	-0.020	3.03	0.77
532	77.485	0.146	2.08	94	-0.04	99	83	-0.030	3.34	0.83
533	77.630	0.145	2.07	94	-0.24	99	83	-0.020	3.14	0.84
534	77.775	0.145	2.07	94	-2.13	99	84	-0.020	3.12	0.84
535	77.919	0.145	2.06	94	-2.53	98	84	-0.010	3.19	0.83
536	78.065	0.145	2.07	94	-0.02	99	84	-0.040	3.04	0.90
537	78.210	0.146	2.08	94	-0.45	99	84	-0.010	3.54	0.85
538	78.356	0.146	2.08	94	-0.21	99	84	-0.010	3.44	0.81
539	78.501	0.145	2.07	94	-0.02	99	84	-0.030	3.10	0.82
540	78.645	0.145	2.06	94	-0.42	98	84	-0.030	3.15	0.90
541	78.791	0.146	2.08	94	-1.21	99	83	-0.010	3.29	0.80
542	78.935	0.145	2.06	94	-2.78	98	83	-0.020	3.29	0.81
543	79.081	0.146	2.09	94	-2.57	99	83	-0.030	2.97	0.80

# BOX B TEST DATA - ASTM E3053 / ASTM E2515

Client: New Buck Corporation

Job #: 19-519

Model: 74

Tracking #: 0042

Run #: 2

Technician: AK

Date: 10/8/2019

Elapsed Time (min)	Particulate Sampling Data							Flue Gas Data		
	Gas Meter (ft <sup>3</sup> )	Sample Rate (cfm)	Orifice dH (in H <sub>2</sub> O)	Meter Temp (°F)	Meter Vacuum (in Hg)	Pro. Rate (%)	Filter (°F)	Flue Draft (in H <sub>2</sub> O)	CO <sub>2</sub> (%)	CO (%)
544	79.226	0.145	2.06	94	-2.3	98	84	-0.030	3.21	0.78
545	79.371	0.146	2.08	94	-2.37	99	84	-0.010	3.20	0.76
546	79.516	0.145	2.07	94	-2.34	99	84	-0.010	3.17	0.79
547	79.662	0.145	2.07	94	-0.4	99	84	-0.030	2.92	0.82
548	79.806	0.145	2.06	94	-2.7	98	84	-0.010	3.20	0.78
549	79.951	0.145	2.07	94	-0.24	99	84	-0.020	2.84	0.80
550	80.096	0.145	2.07	94	-2.58	99	83	-0.010	3.17	0.75
551	80.241	0.145	2.07	94	-1.07	99	83	-0.020	2.99	0.79
552	80.387	0.146	2.08	94	-0.01	99	83	-0.020	3.06	0.77
553	80.532	0.145	2.07	94	-2.63	99	83	-0.020	3.05	0.75
554	80.677	0.146	2.08	94	-2.11	99	84	-0.030	2.82	0.79
555	80.823	0.146	2.08	94	-0.51	99	84	-0.020	3.17	0.73
556	80.968	0.145	2.07	94	-1.97	99	84	-0.020	2.75	0.77
557	81.113	0.145	2.07	93	-0.59	99	84	-0.020	2.85	0.75
558	81.259	0.146	2.09	93	0	100	84	-0.020	2.82	0.77
559	81.404	0.145	2.07	93	-0.02	99	83	-0.010	2.92	0.81
560	81.550	0.146	2.08	93	-0.39	99	83	-0.040	2.51	0.78
561	81.695	0.145	2.07	93	-0.03	99	83	-0.030	2.92	0.78
562	81.840	0.146	2.08	93	0	99	83	-0.020	2.86	0.70
563	81.985	0.145	2.06	93	-2.79	98	83	-0.030	2.76	0.72
564	82.130	0.146	2.08	93	-2.28	99	84	-0.020	3.10	0.73
565	82.275	0.145	2.07	93	-0.21	99	84	-0.020	2.63	0.73
566	82.420	0.145	2.07	93	-1.06	99	84	-0.040	2.73	0.77
567	82.565	0.145	2.07	93	-2.68	99	84	-0.030	2.81	0.70
568	82.710	0.145	2.07	93	-0.63	99	84	-0.020	2.82	0.72
569	82.854	0.144	2.05	93	-2.06	98	83	-0.020	2.95	0.76
570	82.999	0.145	2.06	93	-1.26	98	83	-0.010	2.83	0.72
Avg/Tot	82.999	0.146	2.08	99	-1.41	100	85	-0.004	7.10	0.98

## LAB SAMPLE DATA - ASTM E2515

Client: New Buck Corporation  
 Model: 74  
 Run #: 2

Job #: 19-519  
 Tracking #: 0042  
 Technician: AK  
 Date: 10/8/2019

	Sample ID	Tare, mg	Total, mg	Final, mg	Catch, mg
<b>Train A Filters - First Hour</b>	T346	88.2	177.1	181.5	4.4
	T347	88.9			
<b>Train A Filters - Remainder</b>	T354	86.4	172.8	175.0	2.2
	T348	86.4			
<b>Train A Probe</b>	6A	116545.9	116545.9	116546.1	0.2
<b>Train A O-Rings</b>	6A	3616.3	3616.3	3619.6	3.3
<b>Train B Filters</b>	T349	86.6	261.4	271.3	9.9
	T350	88.5			
	T353	86.3			
<b>Train B Probe</b>	6B	116119.4	116119.4	116119.4	0.0
<b>Train B O-Rings</b>	6B	3397.6	3397.6	3397.6	0.0
<b>Background Filter</b>			0.0	0.0	

<b>Placed in Dessicator on:</b>	10/8/2019
---------------------------------	-----------

<b>Train A Filters - First Hour</b>	181.6	10/10 8:48	181.5	10/15 11:33		
<b>Train A Filters - Remainder</b>	175.2	10/10 8:48	175.0	10/15 11:34		
<b>Train A Probe</b>	116546.0	10/10 8:44	116546.1	10/15 11:25		
<b>Train A O-Rings</b>	3619.6	10/10 8:40	3619.6	10/15 11:22		
<b>Train B Filters</b>	271.4	10/10 8:48	271.3	10/15 11:34		
<b>Train B Probe</b>	116119.4	10/10 8:45	116119.4	10/15 11:25		
<b>Train B O-Rings</b>	3397.7	10/10 8:41	3397.6	10/15 11:23		
<b>Background Filter</b>						

1st hour Sub-Total, mg:	4.4
Remainder Sub-Total, mg:	5.7
<b>Train 1 Aggregate, mg:</b>	<b>10.1</b>
<b>Train 2 Aggregate, mg:</b>	<b>9.9</b>
Ambient Aggregate, mg:	0.0

# WOODSTOVE SURFACE TEMPERATURE DATA

Client: New Buck Corporation  
 Model: 74  
 Run #: 2

Job #: 19-519  
 Tracking #: 0042  
 Technician: AK  
 Date: 10/8/2019

Elapsed Time (min)	Temperature Data (°F)						Stove Surface Average	Catalyst Exit
	FB Left	FB Right	FB Back	FB Top	FB Bottom			
0	498	473	162	245	172	310.0	N/A	
1	499	472	169	248	170	311.6	N/A	
2	496	468	169	248	170	310.2	N/A	
3	489	461	166	246	172	306.8	N/A	
4	483	454	164	246	173	304.0	N/A	
5	479	447	162	249	174	302.2	N/A	
6	475	442	160	254	175	301.2	N/A	
7	469	435	159	262	176	300.2	N/A	
8	465	429	159	270	177	300.0	N/A	
9	462	424	159	279	176	300.0	N/A	
10	462	419	158	289	177	301.0	N/A	
11	462	415	158	298	176	301.8	N/A	
12	460	412	157	309	177	303.0	N/A	
13	457	410	156	319	178	304.0	N/A	
14	459	409	157	328	178	306.2	N/A	
15	458	407	157	335	177	306.8	N/A	
16	458	406	157	339	178	307.6	N/A	
17	456	404	157	340	177	306.8	N/A	
18	451	401	157	340	178	305.4	N/A	
19	450	399	156	338	178	304.2	N/A	
20	447	396	156	335	177	302.2	N/A	
21	445	393	156	332	177	300.6	N/A	
22	443	391	156	329	177	299.2	N/A	
23	440	389	156	327	177	297.8	N/A	
24	438	387	155	326	177	296.6	N/A	
25	437	384	155	324	176	295.2	N/A	
26	437	383	154	323	177	294.8	N/A	
27	436	381	153	321	176	293.4	N/A	
28	435	381	153	321	177	293.4	N/A	
29	435	379	152	321	177	292.8	N/A	
30	432	378	152	321	176	291.8	N/A	
31	431	378	151	320	176	291.2	N/A	
32	432	377	151	320	175	291.0	N/A	
33	430	376	151	321	175	290.6	N/A	
34	431	376	150	321	175	290.6	N/A	
35	432	376	150	320	174	290.4	N/A	
36	432	376	149	321	174	290.4	N/A	
37	431	375	149	320	173	289.6	N/A	
38	432	375	149	320	173	289.8	N/A	
39	433	375	148	320	173	289.8	N/A	
40	431	375	148	320	172	289.2	N/A	
41	432	375	148	321	172	289.6	N/A	
42	433	375	147	320	171	289.2	N/A	
43	432	376	147	320	171	289.2	N/A	
44	433	376	147	320	171	289.4	N/A	
45	433	376	146	320	171	289.2	N/A	
46	434	376	146	320	170	289.2	N/A	
47	433	376	145	320	170	288.8	N/A	

# WOODSTOVE SURFACE TEMPERATURE DATA

Client: New Buck Corporation  
 Model: 74  
 Run #: 2

Job #: 19-519  
 Tracking #: 0042  
 Technician: AK  
 Date: 10/8/2019

Elapsed Time (min)	Temperature Data (°F)						
	FB Left	FB Right	FB Back	FB Top	FB Bottom	Stove Surface Average	Catalyst Exit
48	433	377	145	319	170	288.8	N/A
49	435	377	145	319	170	289.2	N/A
50	433	377	144	318	169	288.2	N/A
51	434	377	145	318	168	288.4	N/A
52	433	377	144	317	168	287.8	N/A
53	433	377	144	316	168	287.6	N/A
54	434	377	144	316	167	287.6	N/A
55	433	377	144	315	167	287.2	N/A
56	434	378	144	315	167	287.6	N/A
57	435	377	144	314	166	287.2	N/A
58	433	378	144	312	165	286.4	N/A
59	435	378	143	311	165	286.4	N/A
60	435	378	143	310	164	286.0	N/A
61	435	378	143	308	163	285.4	N/A
62	437	378	143	308	163	285.8	N/A
63	437	378	142	306	163	285.2	N/A
64	438	378	142	304	162	284.8	N/A
65	437	379	142	303	162	284.6	N/A
66	439	378	142	302	162	284.6	N/A
67	439	379	142	301	161	284.4	N/A
68	439	379	142	300	160	284.0	N/A
69	440	380	141	299	160	284.0	N/A
70	441	380	141	298	160	284.0	N/A
71	443	381	141	297	160	284.4	N/A
72	444	382	141	297	160	284.8	N/A
73	445	383	141	296	160	285.0	N/A
74	447	383	142	296	159	285.4	N/A
75	447	383	141	295	159	285.0	N/A
76	448	384	142	295	159	285.6	N/A
77	451	385	141	295	159	286.2	N/A
78	449	386	141	295	159	286.0	N/A
79	451	387	141	294	159	286.4	N/A
80	451	387	141	295	159	286.6	N/A
81	452	388	141	295	158	286.8	N/A
82	455	389	142	296	158	288.0	N/A
83	456	391	142	296	158	288.6	N/A
84	457	392	142	297	158	289.2	N/A
85	458	393	142	297	158	289.6	N/A
86	461	395	143	298	159	291.2	N/A
87	460	396	143	299	159	291.4	N/A
88	463	398	143	300	159	292.6	N/A
89	465	399	143	301	159	293.4	N/A
90	465	401	143	302	159	294.0	N/A
91	468	402	142	303	159	294.8	N/A
92	470	404	142	304	159	295.8	N/A
93	471	406	143	305	159	296.8	N/A
94	470	407	143	305	158	296.6	N/A
95	470	409	143	306	158	297.2	N/A



# WOODSTOVE SURFACE TEMPERATURE DATA

Client: New Buck Corporation  
 Model: 74  
 Run #: 2

Job #: 19-519  
 Tracking #: 0042  
 Technician: AK  
 Date: 10/8/2019

Elapsed Time (min)	Temperature Data (°F)						
	FB Left	FB Right	FB Back	FB Top	FB Bottom	Stove Surface Average	Catalyst Exit
96	471	410	143	307	158	297.8	N/A
97	473	413	144	307	158	299.0	N/A
98	473	415	144	307	158	299.4	N/A
99	473	416	144	307	158	299.6	N/A
100	473	419	144	308	158	300.4	N/A
101	474	421	144	308	158	301.0	N/A
102	474	422	144	308	158	301.2	N/A
103	475	425	144	308	158	302.0	N/A
104	474	427	145	308	159	302.6	N/A
105	474	429	144	308	159	302.8	N/A
106	477	431	145	308	160	304.2	N/A
107	476	433	144	308	159	304.0	N/A
108	476	434	144	307	160	304.2	N/A
109	473	436	144	307	159	303.8	N/A
110	474	437	144	305	159	303.8	N/A
111	474	438	145	305	159	304.2	N/A
112	475	440	145	303	159	304.4	N/A
113	473	441	146	302	159	304.2	N/A
114	476	442	145	301	159	304.6	N/A
115	476	444	145	300	159	304.8	N/A
116	475	445	145	298	159	304.4	N/A
117	474	446	146	297	159	304.4	N/A
118	474	445	146	296	158	303.8	N/A
119	472	446	146	295	158	303.4	N/A
120	471	447	146	295	158	303.4	N/A
121	471	447	146	294	157	303.0	N/A
122	471	447	146	292	158	302.8	N/A
123	469	447	146	291	158	302.2	N/A
124	469	447	147	290	158	302.2	N/A
125	469	447	147	288	158	301.8	N/A
126	468	447	146	287	158	301.2	N/A
127	465	447	147	284	159	300.4	N/A
128	464	447	147	283	159	300.0	N/A
129	464	446	147	281	159	299.4	N/A
130	463	447	147	280	159	299.2	N/A
131	462	447	147	278	159	298.6	N/A
132	461	447	146	276	159	297.8	76
133	461	446	146	275	159	297.4	76
134	460	446	146	273	159	296.8	77
135	460	446	146	271	159	296.4	N/A
136	458	445	146	268	160	295.4	N/A
137	459	444	147	266	159	295.0	78
138	458	443	146	264	160	294.2	N/A
139	458	442	146	262	160	293.6	N/A
140	457	441	146	260	160	292.8	N/A
141	457	439	146	258	160	292.0	66
142	456	438	145	255	160	290.8	N/A
143	453	437	145	253	160	289.6	N/A

# WOODSTOVE SURFACE TEMPERATURE DATA

Client: New Buck Corporation  
 Model: 74  
 Run #: 2

Job #: 19-519  
 Tracking #: 0042  
 Technician: AK  
 Date: 10/8/2019

Elapsed Time (min)	Temperature Data (°F)						Stove Surface Average	Catalyst Exit
	FB Left	FB Right	FB Back	FB Top	FB Bottom			
144	453	436	145	251	161	289.2	N/A	
145	451	435	144	249	160	287.8	N/A	
146	447	434	144	247	160	286.4	N/A	
147	449	433	144	245	160	286.2	N/A	
148	448	432	144	243	160	285.4	N/A	
149	447	430	144	241	160	284.4	N/A	
150	447	430	144	239	160	284.0	N/A	
151	446	428	144	237	160	283.0	N/A	
152	443	427	144	235	160	281.8	N/A	
153	442	425	143	233	160	280.6	N/A	
154	440	424	143	232	160	279.8	N/A	
155	438	422	143	230	160	278.6	N/A	
156	439	421	142	229	160	278.2	N/A	
157	436	420	142	227	160	277.0	N/A	
158	433	418	142	225	160	275.6	N/A	
159	430	416	142	223	160	274.2	N/A	
160	431	415	141	222	159	273.6	N/A	
161	427	414	141	220	160	272.4	N/A	
162	427	412	140	219	159	271.4	N/A	
163	426	411	140	217	159	270.6	N/A	
164	424	409	139	216	159	269.4	N/A	
165	422	407	139	214	159	268.2	N/A	
166	421	406	139	212	158	267.2	N/A	
167	419	404	138	211	158	266.0	N/A	
168	418	402	138	209	158	265.0	N/A	
169	418	401	138	208	157	264.4	N/A	
170	415	399	138	206	157	263.0	N/A	
171	414	398	138	205	158	262.6	N/A	
172	413	396	137	203	158	261.4	N/A	
173	410	395	137	202	157	260.2	N/A	
174	412	394	137	201	157	260.2	N/A	
175	410	393	136	200	157	259.2	N/A	
176	409	391	136	199	157	258.4	N/A	
177	407	390	136	198	157	257.6	N/A	
178	405	388	136	196	157	256.4	N/A	
179	406	388	136	195	156	256.2	N/A	
180	403	387	135	194	156	255.0	N/A	
181	402	386	135	193	156	254.4	N/A	
182	401	385	135	192	156	253.8	N/A	
183	401	384	135	192	156	253.6	N/A	
184	401	384	134	190	156	253.0	N/A	
185	399	383	135	190	156	252.6	N/A	
186	399	382	135	189	156	252.2	N/A	
187	397	381	134	188	156	251.2	N/A	
188	398	381	134	188	156	251.4	N/A	
189	396	380	134	187	156	250.6	N/A	
190	396	378	133	186	155	249.6	N/A	
191	394	378	133	185	155	249.0	N/A	

# WOODSTOVE SURFACE TEMPERATURE DATA

Client: New Buck Corporation  
 Model: 74  
 Run #: 2

Job #: 19-519  
 Tracking #: 0042  
 Technician: AK  
 Date: 10/8/2019

Elapsed Time (min)	Temperature Data (°F)						
	FB Left	FB Right	FB Back	FB Top	FB Bottom	Stove Surface Average	Catalyst Exit
192	394	377	133	185	154	248.6	N/A
193	393	375	133	184	154	247.8	N/A
194	392	374	133	183	154	247.2	N/A
195	392	373	132	183	154	246.8	N/A
196	389	370	132	182	153	245.2	N/A
197	389	368	131	181	152	244.2	N/A
198	389	366	131	181	152	243.8	N/A
199	388	364	131	179	152	242.8	N/A
200	388	362	131	179	152	242.4	N/A
201	385	361	130	178	152	241.2	N/A
202	385	358	131	177	152	240.6	N/A
203	386	357	130	176	152	240.2	N/A
204	384	356	130	176	152	239.6	N/A
205	381	354	130	175	151	238.2	N/A
206	381	353	130	175	152	238.2	N/A
207	381	351	130	174	151	237.4	N/A
208	380	350	130	173	151	236.8	N/A
209	380	348	130	173	151	236.4	N/A
210	377	348	130	172	151	235.6	N/A
211	377	346	129	172	150	234.8	N/A
212	376	345	129	171	150	234.2	N/A
213	376	344	129	171	151	234.2	N/A
214	374	342	129	170	150	233.0	N/A
215	374	341	128	169	150	232.4	N/A
216	373	340	128	169	150	232.0	N/A
217	371	339	128	168	150	231.2	N/A
218	370	338	128	168	149	230.6	N/A
219	369	337	128	167	149	230.0	N/A
220	369	336	127	167	149	229.6	N/A
221	367	334	127	166	149	228.6	N/A
222	368	334	128	166	149	229.0	N/A
223	366	332	127	165	149	227.8	N/A
224	366	331	127	164	149	227.4	N/A
225	364	330	127	164	148	226.6	N/A
226	363	329	127	163	148	226.0	N/A
227	361	328	126	163	148	225.2	N/A
228	360	327	126	162	148	224.6	N/A
229	359	326	126	162	147	224.0	N/A
230	359	325	126	161	146	223.4	N/A
231	359	324	125	161	146	223.0	N/A
232	358	324	125	160	147	222.8	N/A
233	357	323	125	160	146	222.2	N/A
234	357	322	125	160	146	222.0	N/A
235	356	321	125	159	146	221.4	N/A
236	353	320	125	158	146	220.4	N/A
237	352	319	124	158	146	219.8	N/A
238	351	318	124	158	146	219.4	N/A
239	352	317	124	157	146	219.2	N/A

# WOODSTOVE SURFACE TEMPERATURE DATA

Client: New Buck Corporation  
 Model: 74  
 Run #: 2

Job #: 19-519  
 Tracking #: 0042  
 Technician: AK  
 Date: 10/8/2019

Elapsed Time (min)	Temperature Data (°F)						Catalyst Exit
	FB Left	FB Right	FB Back	FB Top	FB Bottom	Stove Surface Average	
240	350	317	124	157	146	218.8	N/A
241	350	316	124	157	146	218.6	N/A
242	349	315	124	156	145	217.8	N/A
243	346	314	123	155	145	216.6	N/A
244	346	313	123	155	145	216.4	N/A
245	343	312	123	155	145	215.6	N/A
246	344	311	123	154	145	215.4	N/A
247	344	311	123	154	145	215.4	N/A
248	342	310	122	154	146	214.8	N/A
249	340	309	122	153	145	213.8	N/A
250	341	309	122	153	145	214.0	N/A
251	340	307	122	153	145	213.4	N/A
252	340	307	121	152	145	213.0	N/A
253	338	306	121	152	145	212.4	N/A
254	337	305	121	151	144	211.6	N/A
255	336	304	121	151	144	211.2	N/A
256	336	304	121	150	144	211.0	N/A
257	334	303	120	150	144	210.2	N/A
258	333	302	120	150	144	209.8	N/A
259	331	301	120	149	144	209.0	N/A
260	332	300	120	149	144	209.0	N/A
261	331	299	120	148	143	208.2	N/A
262	329	298	120	148	143	207.6	N/A
263	329	298	119	148	143	207.4	N/A
264	329	296	120	148	143	207.2	N/A
265	326	296	119	147	142	206.0	N/A
266	327	295	119	147	142	206.0	N/A
267	327	294	119	146	142	205.6	N/A
268	325	294	119	146	141	205.0	N/A
269	325	293	119	146	141	204.8	N/A
270	323	292	118	145	141	203.8	N/A
271	323	292	118	145	140	203.6	N/A
272	324	290	118	145	141	203.6	N/A
273	322	291	118	145	141	203.4	N/A
274	322	290	118	144	140	202.8	N/A
275	322	289	118	144	140	202.6	N/A
276	321	289	118	144	139	202.2	N/A
277	320	288	117	143	140	201.6	N/A
278	319	287	117	143	139	201.0	N/A
279	319	287	117	143	139	201.0	N/A
280	318	286	117	142	139	200.4	N/A
281	318	285	117	142	139	200.2	N/A
282	317	285	117	141	139	199.8	N/A
283	316	284	116	141	139	199.2	N/A
284	315	283	116	141	139	198.8	N/A
285	314	282	116	141	139	198.4	N/A
286	314	282	116	140	138	198.0	N/A
287	312	281	116	140	138	197.4	N/A

# WOODSTOVE SURFACE TEMPERATURE DATA

Client: New Buck Corporation  
 Model: 74  
 Run #: 2

Job #: 19-519  
 Tracking #: 0042  
 Technician: AK  
 Date: 10/8/2019

Elapsed Time (min)	Temperature Data (°F)						Catalyst Exit
	FB Left	FB Right	FB Back	FB Top	FB Bottom	Stove Surface Average	
288	311	281	116	140	138	197.2	N/A
289	310	280	116	140	138	196.8	N/A
290	310	279	115	139	138	196.2	N/A
291	309	279	115	139	138	196.0	N/A
292	308	278	115	138	137	195.2	N/A
293	306	277	115	138	137	194.6	N/A
294	306	277	115	138	137	194.6	N/A
295	306	276	115	138	137	194.4	N/A
296	306	276	115	138	137	194.4	N/A
297	305	276	115	137	136	193.8	N/A
298	303	275	115	137	136	193.2	N/A
299	304	275	115	137	136	193.4	N/A
300	303	275	114	137	136	193.0	N/A
301	302	274	114	137	136	192.6	N/A
302	302	273	114	137	135	192.2	N/A
303	300	273	114	136	135	191.6	N/A
304	299	273	114	136	135	191.4	N/A
305	299	272	114	136	135	191.2	N/A
306	299	272	113	136	135	191.0	N/A
307	298	272	113	136	135	190.8	N/A
308	298	271	113	135	135	190.4	N/A
309	296	271	113	135	135	190.0	N/A
310	296	272	113	135	134	190.0	N/A
311	293	271	113	135	134	189.2	N/A
312	294	270	113	135	134	189.2	N/A
313	294	270	113	134	134	189.0	N/A
314	294	270	113	134	134	189.0	N/A
315	294	270	113	134	134	189.0	N/A
316	292	270	113	134	134	188.6	N/A
317	291	269	112	133	133	187.6	N/A
318	291	269	112	133	133	187.6	N/A
319	290	269	112	133	133	187.4	N/A
320	289	268	112	133	132	186.8	N/A
321	288	268	112	133	132	186.6	N/A
322	288	268	112	133	133	186.8	N/A
323	288	268	112	133	133	186.8	N/A
324	288	267	112	133	132	186.4	N/A
325	286	267	111	132	132	185.6	N/A
326	286	267	112	132	131	185.6	N/A
327	285	267	111	132	131	185.2	N/A
328	285	267	111	132	131	185.2	N/A
329	284	267	111	132	131	185.0	N/A
330	283	266	111	131	130	184.2	N/A
331	282	266	111	131	131	184.2	N/A
332	283	266	111	131	130	184.2	N/A
333	281	266	110	131	130	183.6	N/A
334	280	265	111	131	130	183.4	N/A
335	279	265	111	130	130	183.0	N/A

# WOODSTOVE SURFACE TEMPERATURE DATA

Client: New Buck Corporation

Job #: 19-519

Model: 74

Tracking #: 0042

Run #: 2

Technician: AK

Date: 10/8/2019

Elapsed Time (min)	Temperature Data (°F)						Stove Surface Average	Catalyst Exit
	FB Left	FB Right	FB Back	FB Top	FB Bottom			
336	279	265	110	130	130	182.8	N/A	
337	278	264	110	130	130	182.4	N/A	
338	278	264	110	130	130	182.4	N/A	
339	278	264	110	130	130	182.4	N/A	
340	277	264	110	130	130	182.2	N/A	
341	275	263	110	130	130	181.6	N/A	
342	275	263	110	130	130	181.6	N/A	
343	273	262	110	129	130	180.8	N/A	
344	274	262	110	129	130	181.0	N/A	
345	273	262	110	129	130	180.8	N/A	
346	272	261	110	129	130	180.4	N/A	
347	272	262	110	129	130	180.6	N/A	
348	271	261	109	128	130	179.8	N/A	
349	270	260	109	128	130	179.4	N/A	
350	270	260	109	128	130	179.4	N/A	
351	269	260	109	128	130	179.2	N/A	
352	270	260	109	128	130	179.4	N/A	
353	266	259	109	128	129	178.2	N/A	
354	266	259	109	127	129	178.0	N/A	
355	266	258	109	127	130	178.0	N/A	
356	264	258	108	127	129	177.2	N/A	
357	264	257	108	127	129	177.0	N/A	
358	264	257	108	127	129	177.0	N/A	
359	263	257	108	127	129	176.8	N/A	
360	263	256	108	127	129	176.6	N/A	
361	262	256	108	126	128	176.0	N/A	
362	261	255	108	126	129	175.8	N/A	
363	260	255	108	126	129	175.6	N/A	
364	259	255	108	126	129	175.4	N/A	
365	258	254	108	125	129	174.8	N/A	
366	258	254	108	125	129	174.8	N/A	
367	257	253	108	125	129	174.4	N/A	
368	257	254	107	125	129	174.4	N/A	
369	256	253	107	125	129	174.0	N/A	
370	255	253	107	125	128	173.6	N/A	
371	253	253	107	125	128	173.2	N/A	
372	253	253	107	125	128	173.2	N/A	
373	252	252	107	124	128	172.6	N/A	
374	253	252	107	124	128	172.8	N/A	
375	251	251	107	124	128	172.2	N/A	
376	250	251	107	124	127	171.8	N/A	
377	250	251	107	124	127	171.8	N/A	
378	248	250	107	124	127	171.2	N/A	
379	249	248	107	124	127	171.0	N/A	
380	250	250	107	124	127	171.6	N/A	
381	248	250	106	123	127	170.8	N/A	
382	248	249	106	123	127	170.6	N/A	
383	247	249	106	123	127	170.4	N/A	

# WOODSTOVE SURFACE TEMPERATURE DATA

Client: New Buck Corporation  
 Model: 74  
 Run #: 2

Job #: 19-519  
 Tracking #: 0042  
 Technician: AK  
 Date: 10/8/2019

Elapsed Time (min)	Temperature Data (°F)						Catalyst Exit
	FB Left	FB Right	FB Back	FB Top	FB Bottom	Stove Surface Average	
384	246	249	106	123	127	170.2	N/A
385	244	249	106	122	127	169.6	N/A
386	244	248	106	123	127	169.6	N/A
387	245	248	106	122	127	169.6	N/A
388	243	248	106	122	127	169.2	N/A
389	243	248	106	122	126	169.0	N/A
390	242	248	106	122	126	168.8	N/A
391	243	247	106	122	126	168.8	N/A
392	243	247	106	122	126	168.8	N/A
393	242	247	106	122	126	168.6	N/A
394	240	248	106	122	126	168.4	N/A
395	240	247	106	121	126	168.0	N/A
396	240	247	106	121	126	168.0	N/A
397	239	247	106	121	125	167.6	N/A
398	239	247	106	121	126	167.8	N/A
399	238	247	106	121	125	167.4	N/A
400	238	248	106	121	125	167.6	N/A
401	237	248	106	121	126	167.6	N/A
402	237	248	106	120	125	167.2	N/A
403	236	247	105	120	125	166.6	N/A
404	237	248	105	120	125	167.0	N/A
405	235	248	105	120	125	166.6	N/A
406	236	248	105	120	125	166.8	N/A
407	236	248	105	120	125	166.8	N/A
408	236	248	105	119	125	166.6	N/A
409	235	248	105	120	125	166.6	N/A
410	234	248	105	119	124	166.0	N/A
411	234	248	105	120	124	166.2	N/A
412	234	248	105	119	125	166.2	N/A
413	234	248	105	119	124	166.0	N/A
414	232	247	105	119	124	165.4	N/A
415	233	247	105	119	123	165.4	N/A
416	232	247	104	119	124	165.2	N/A
417	231	247	104	119	123	164.8	N/A
418	232	246	104	119	123	164.8	N/A
419	232	246	104	119	123	164.8	N/A
420	231	246	104	119	122	164.4	N/A
421	231	246	104	119	122	164.4	N/A
422	231	246	104	119	122	164.4	N/A
423	230	246	104	119	122	164.2	N/A
424	230	245	104	119	122	164.0	N/A
425	231	245	104	119	122	164.2	N/A
426	229	245	104	119	122	163.8	N/A
427	229	245	104	118	122	163.6	N/A
428	228	245	104	118	122	163.4	N/A
429	229	245	104	118	122	163.6	N/A
430	228	244	104	118	122	163.2	N/A
431	228	244	104	118	122	163.2	N/A

# WOODSTOVE SURFACE TEMPERATURE DATA

Client: New Buck Corporation  
 Model: 74  
 Run #: 2

Job #: 19-519  
 Tracking #: 0042  
 Technician: AK  
 Date: 10/8/2019

Elapsed Time (min)	Temperature Data (°F)						Stove Surface Average	Catalyst Exit
	FB Left	FB Right	FB Back	FB Top	FB Bottom			
432	227	244	104	118	122	163.0	N/A	
433	228	244	104	118	122	163.2	N/A	
434	227	244	104	118	122	163.0	N/A	
435	227	244	104	118	122	163.0	N/A	
436	226	243	104	118	122	162.6	N/A	
437	226	243	104	118	122	162.6	N/A	
438	227	243	104	118	122	162.8	N/A	
439	227	243	104	117	122	162.6	N/A	
440	226	242	104	118	121	162.2	N/A	
441	225	242	104	117	121	161.8	N/A	
442	226	242	104	118	122	162.4	N/A	
443	226	242	104	118	122	162.4	N/A	
444	225	242	104	117	121	161.8	N/A	
445	225	242	104	117	121	161.8	N/A	
446	226	241	104	117	121	161.8	N/A	
447	225	241	104	117	121	161.6	N/A	
448	224	241	104	117	121	161.4	N/A	
449	225	241	104	117	120	161.4	N/A	
450	224	241	104	117	120	161.2	N/A	
451	224	240	104	117	120	161.0	N/A	
452	224	240	104	117	120	161.0	N/A	
453	222	240	104	117	120	160.6	N/A	
454	223	240	104	117	120	160.8	N/A	
455	223	240	104	117	120	160.8	N/A	
456	222	239	104	117	120	160.4	N/A	
457	222	239	104	117	120	160.4	N/A	
458	222	239	104	117	120	160.4	N/A	
459	221	239	104	116	120	160.0	N/A	
460	221	239	104	117	120	160.2	N/A	
461	221	239	103	117	120	160.0	N/A	
462	220	238	103	116	120	159.4	N/A	
463	220	238	104	116	119	159.4	N/A	
464	219	238	103	116	120	159.2	N/A	
465	219	238	103	116	120	159.2	N/A	
466	219	238	103	116	120	159.2	N/A	
467	218	237	103	116	120	158.8	N/A	
468	218	237	103	116	119	158.6	N/A	
469	218	237	103	116	119	158.6	N/A	
470	217	237	103	116	120	158.6	N/A	
471	216	236	103	115	120	158.0	N/A	
472	216	237	103	116	120	158.4	N/A	
473	216	236	103	116	120	158.2	N/A	
474	216	236	103	116	119	158.0	N/A	
475	215	236	103	115	119	157.6	N/A	
476	216	236	103	115	119	157.8	N/A	
477	215	235	103	115	119	157.4	N/A	
478	214	235	103	115	119	157.2	N/A	
479	214	235	103	115	119	157.2	N/A	



# WOODSTOVE SURFACE TEMPERATURE DATA

Client: New Buck Corporation  
 Model: 74  
 Run #: 2

Job #: 19-519  
 Tracking #: 0042  
 Technician: AK  
 Date: 10/8/2019

Elapsed Time (min)	Temperature Data (°F)						Catalyst Exit
	FB Left	FB Right	FB Back	FB Top	FB Bottom	Stove Surface Average	
480	215	235	102	115	119	157.2	N/A
481	214	234	102	115	119	156.8	N/A
482	213	235	102	115	119	156.8	N/A
483	213	235	102	114	119	156.6	N/A
484	213	235	102	114	119	156.6	N/A
485	213	234	102	115	119	156.6	N/A
486	212	234	102	114	119	156.2	N/A
487	212	234	101	114	119	156.0	N/A
488	212	235	101	114	119	156.2	N/A
489	212	234	101	114	119	156.0	N/A
490	210	234	101	114	119	155.6	N/A
491	210	235	101	114	119	155.8	N/A
492	210	235	101	113	119	155.6	N/A
493	210	234	101	113	119	155.4	N/A
494	210	234	101	114	119	155.6	N/A
495	208	235	101	113	119	155.2	N/A
496	209	234	101	113	119	155.2	N/A
497	209	235	100	113	119	155.2	N/A
498	208	235	101	113	118	155.0	N/A
499	208	235	100	113	118	154.8	N/A
500	206	235	100	113	118	154.4	N/A
501	207	235	100	113	118	154.6	N/A
502	206	235	100	113	118	154.4	N/A
503	206	235	100	113	118	154.4	N/A
504	206	235	100	113	118	154.4	N/A
505	205	235	100	112	118	154.0	N/A
506	204	235	100	112	117	153.6	N/A
507	204	235	100	112	116	153.4	N/A
508	203	235	100	112	116	153.2	N/A
509	204	235	100	112	116	153.4	N/A
510	203	235	100	112	116	153.2	N/A
511	202	235	99	112	116	152.8	N/A
512	202	235	100	111	116	152.8	N/A
513	201	235	99	111	115	152.2	N/A
514	200	235	99	111	115	152.0	N/A
515	201	235	99	111	115	152.2	N/A
516	200	235	99	111	114	151.8	N/A
517	200	235	99	111	114	151.8	N/A
518	200	235	99	111	114	151.8	N/A
519	199	235	99	110	114	151.4	N/A
520	198	235	99	110	114	151.2	N/A
521	197	235	99	110	114	151.0	N/A
522	197	235	99	110	114	151.0	N/A
523	197	234	98	110	113	150.4	N/A
524	196	234	98	110	113	150.2	N/A
525	195	234	98	109	114	150.0	N/A
526	195	234	98	110	113	150.0	N/A
527	195	233	98	110	113	149.8	N/A

# WOODSTOVE SURFACE TEMPERATURE DATA

Client: New Buck Corporation  
 Model: 74  
 Run #: 2

Job #: 19-519  
 Tracking #: 0042  
 Technician: AK  
 Date: 10/8/2019

Elapsed Time (min)	Temperature Data (°F)						Catalyst Exit
	FB Left	FB Right	FB Back	FB Top	FB Bottom	Stove Surface Average	
528	194	233	98	109	113	149.4	N/A
529	194	233	98	109	113	149.4	N/A
530	193	232	97	109	113	148.8	N/A
531	192	232	98	109	113	148.8	N/A
532	192	232	98	109	112	148.6	N/A
533	191	231	97	109	113	148.2	N/A
534	190	231	97	108	112	147.6	N/A
535	189	230	97	108	112	147.2	N/A
536	189	230	97	108	112	147.2	N/A
537	189	229	97	108	112	147.0	N/A
538	188	229	97	108	111	146.6	N/A
539	188	228	97	108	111	146.4	N/A
540	187	228	97	107	111	146.0	N/A
541	186	228	96	107	111	145.6	N/A
542	187	227	96	107	111	145.6	N/A
543	185	226	96	107	111	145.0	N/A
544	185	226	96	107	111	145.0	N/A
545	183	226	96	107	111	144.6	N/A
546	183	225	96	106	111	144.2	N/A
547	183	225	96	106	111	144.2	N/A
548	182	224	95	106	110	143.4	N/A
549	181	223	95	106	110	143.0	N/A
550	181	223	96	106	110	143.2	N/A
551	181	222	95	106	110	142.8	N/A
552	181	222	95	106	110	142.8	N/A
553	180	221	95	105	110	142.2	N/A
554	179	221	95	105	109	141.8	N/A
555	179	220	95	105	109	141.6	N/A
556	178	219	94	105	109	141.0	N/A
557	178	219	95	105	109	141.2	N/A
558	177	219	95	105	109	141.0	N/A
559	177	218	94	105	108	140.4	N/A
560	176	217	94	104	108	139.8	N/A
561	175	217	94	104	108	139.6	N/A
562	175	217	94	104	108	139.6	N/A
563	174	216	94	104	108	139.2	N/A
564	173	215	94	104	107	138.6	N/A
565	173	215	94	103	107	138.4	N/A
566	172	214	93	104	108	138.2	N/A
567	172	213	93	103	107	137.6	N/A
568	172	212	93	103	107	137.4	N/A
569	171	212	93	103	107	137.2	N/A
570	170	212	93	102	107	136.8	N/A
Average	325	313	121	180	140	216	N/A

## ASTM E3053 Wood Heater Run Sheets

Client: New Buck Corporation Job Number: 19-519 Tracking #: 0042  
 Model: 74 Run Number: 2 Test Date: 10/8/2019

### Wood Heater Run Notes

**Pre-Test Notes**

Pre-Test Start Time: 10:14  
 Air Control Setting: High

Time	Notes
	See run 1 notes

**Test Notes**

Test Burn Start Time: 12:51  
 Air Control Setting: Low

Time	Notes
0:30	Fuel loaded
1:25	Door closed, fan on low
6:00	Air set halfway to low
12:55	Set air to test setting
17:00	Changed filter A for T347
38:00	Changed B for T353
60:00	Changed A for T354

Test Burn End Time: 22:22

### Flue Gas Concentration Measurement

**Calibration Gas Values:** Span Gas CO<sub>2</sub> (%): 15.53 CO (%): 4.084

**Calibration Results:**

	Pre Test		Post Test	
	Zero	Span	Zero	Span
Time	12:40	12:42	22:25	22:28
CO <sub>2</sub>	0.00	15.53	-0.01	15.73
CO	0.000	4.084	0.059	4.198

**Flue Gas Probe Leak Check:** Initial: No Leakage Final: No Leakage

Technician Signature: 

Date: 10/8/2019  
Page 1 of 2

# ASTM E3053 Wood Heater Run Sheets

Client: New Buck Corporation  
Model: 74

Job Number: 19-519  
Run Number: 2

Tracking #: 0042  
Test Date: 10/8/2019



Low Fire Fuel Load



Low Fire Fuel Loaded

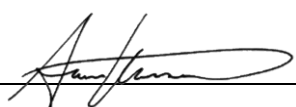

Technician Signature: 

Date: 10/8/2019  
Page 2 of 2

**WOOD STOVE TEST DATA PACKET  
ASTM E3053/E2515**



**Run 3 Data Summary**

Client: New Buck Corporation  
Model: 74  
Job #: 19-519  
Tracking #: 0042  
Test Date: 10/9/2019

A handwritten signature in black ink, appearing to read "A. [unclear]", is written over a horizontal line.

Techician Signature

10/16/2019

Date

# TEST RESULTS - ASTM E3053 / ASTM E2515

Client: New Buck Corporation  
 Model: 74  
 Run #: 3

Job #: 19-519  
 Tracking #: 0042  
 Technician: AK  
 Date: 10/9/2019

<b>Burn Rate (kg/hr):</b>	<b>1.15</b>
---------------------------	-------------

	Ambient Sample	Sample Train A	Sample Train B	1st Hour Filter
Total Sample Volume (ft <sup>3</sup> )	0.000	67.869	66.655	8.771
Average Gas Velocity in Dilution Tunnel (ft/sec)	18.53			
Average Gas Flow Rate in Dilution Tunnel (dscf/hr)	12478.1			
Average Gas Meter Temperature (°F)	69.8	102.7	98.2	96.2
Total Sample Volume (dscf)	0.000	64.542	63.711	8.438
Average Tunnel Temperature (°F)	88.3			
Total Time of Test (min)	465			
Total Particulate Catch (mg)	0.0	4.2	4.1	3.6
Particulate Concentration, dry-standard (g/dscf)	0.0000000	0.0000651	0.0000644	0.0004266
Total PM Emissions (g)	0.00	6.29	6.22	5.32
Particulate Emission Rate (g/hr)	0.00	0.81	0.80	5.32
Emissions Factor (g/kg)	-	0.71	0.70	-
Difference from Average Total Particulate Emissions (g)	-	0.03	0.03	-
Difference from Average Emissions Factor (g/kg)	-	0.00	0.00	-

<b>Final Average Results</b>	
Total Particulate Emissions (g)	6.26
Particulate Emission Rate (g/hr)	0.81
Emissions Factor (g/kg)	0.70
HHV Efficiency (%)	74.6%
LHV Efficiency (%)	79.8%
CO Emissions (g/min)	1.63

Quality Checks	Requirement	Observed	Result
Dual Train Precision	Each train within 7.5% of average emissions (in grams), or emission factors within 0.5 g/kg	See Above	OK
Filter Temps	>80 °F, <90 °F	Min: 80 / Max: 90	OK
Face Velocity	< 30 ft/min	8.9	OK
Leakage Rate	Less than 4% of average sample rate	0.002 cfm	OK
Ambient Temp	55-90 °F	Min: 66 / Max: 72	OK
Negative Probe Weight Evaluation	<5% of Total Catch	Probe Catch Not Negative	OK
Pro-Rate Variation	90% of readings between 90-110%; none greater than 120% or less than 80%	See Data Tabs	CHECK 10 MIN. INTERVAL PRO-RATES

# B415.1 Efficiency Results

**Manufacturer:**  $\omega$  Buck Corporation  
**Model:** 74  
**Date:** 10/09/19  
**Run:** 3  
**Control #:** 19-519  
**Test Duration:** 465  
**Output Category:** Medium

### Test Results in Accordance with CSA B415.1-09

	HHV Basis	LHV Basis
<b>Overall Efficiency</b>	74.6%	79.8%
<b>Combustion Efficiency</b>	94.0%	94.0%
<b>Heat Transfer Efficiency</b>	79.4%	84.9%

<b>Output Rate (kJ/h)</b>	16,963	16,091	<b>(Btu/h)</b>
<b>Burn Rate (kg/h)</b>	1.14	2.51	<b>(lb/h)</b>
<b>Input (kJ/h)</b>	22,745	21,576	<b>(Btu/h)</b>

<b>Test Load Weight (dry kg)</b>	8.83	19.46	<b>dry lb</b>
<b>MC wet (%)</b>	19.57		
<b>MC dry (%)</b>	24.33		
<b>Particulate (g )</b>	6.26		
<b>CO (g)</b>	759		
<b>Test Duration (h)</b>	7.75		

Emissions	Particulate	CO
<b>g/MJ Output</b>	0.05	5.77
<b>g/kg Dry Fuel</b>	0.71	85.97
<b>g/h</b>	0.81	97.96
<b>g/min</b>	0.01	1.63
<b>lb/MM Btu Output</b>	0.11	13.42

<b>Air/Fuel Ratio (A/F)</b>	14.58
-----------------------------	-------

**VERSION:** 2.2 **12/14/2009**

## HIGH FIRE FUEL LOAD DATA - ASTM E3053

Client: New Buck Corporation  
 Model: 74  
 Run #: 3

Job #: 19-519  
 Tracking # 0042  
 Technician: AK  
 Date: 10/9/2019

Nominal Loading Density (lbs/ft<sup>3</sup>, wet basis): 10  
 Usable Firebox Volume (ft<sup>3</sup>): 2.15  
 Target Load Weight (lbs): 21.50  
 Total Load Weight Range (lbs): 20.40 to 22.60  
 Core Load Weight Range (lbs): 9.70 to 14.00  
 Remainder Load Weight Range (lbs): 7.50 to 11.80  
 Core Load Piece Range (lbs): 3.20 to 5.40  
 Remainder Load Piece Range (lbs): 2.20 to 11.80  
 Max Allowable Kindling Weight (lbs): 4.19  
 Max Allowable Start-up Fuel Weight (lbs): 6.28

### CORE LOAD DATA

Piece #	Length (in)	Weight (lbs)	Within Spec?	Fuel Piece Moisture Readings (%DB)				Within Spec?	Dry Weight	
				1	2	3	Ave.		lbs	kg
1	16.00	4.98	In Range	25.2	28.0	21.5	24.9	In Range	3.99	1.81
2	16.00	3.88	In Range	18.0	18.7	18.4	18.4	In Range	3.28	1.49
3	16.00	4.45	In Range	22.1	22.6	24.2	23.0	In Range	3.62	1.64
Core Load Wt. (lbs)		13.31	In Range							

### REMAINDER LOAD DATA (1 to 3 Pieces)

Piece #	Length (in)	Weight (lbs)	Within Spec?	Fuel Piece Moisture Readings (%DB)				Within Spec?	Dry Weight	
				1	2	3	Ave.		lbs	kg
1	16.00	4.41	In Range	23.1	23.4	24.7	23.7	In Range	3.56	1.62
2	16.00	3.21	In Range	22.4	20.2	22.1	21.6	In Range	2.64	1.20
3			NA				NA	NA	NA	NA
Remainder Load (lbs)		7.62	In Range							

Total Load Weight (lbs): 20.93 In Range  
 Core Load % of Total Weight: 64% In Range 45-65%  
 Remainder % of Total Weight: 36% In Range 35-55%  
 Total Load % of Target Weight: 97% In Range 95-105%  
 Actual Fuel Loading Density (lb/ft<sup>3</sup>): 9.7  
 Total Load Average Moisture Content (%DB): 22.5 In Range 19-25%  
 Total Load Average Moisture Content (%WB): 18.4  
 Total Test Load Weight (dry basis): 17.09 lbs 7.75 kg

### KINDLING AND START-UP FUEL

Kindling Weight (lbs)	Within Spec?	Kindling Moisture Readings (%DB)				Within Spec?	Dry Weight	
		1	2	3	Avg.		lbs	kg
3.99	In Range	12	11.5	11.6	11.7	In Range	3.57	1.62

Start-up Fuel Wt. (lb)	Within Spec?	Start-up Moisture Readings (%DB)				Within Spec?	Dry Weight	
		1	2	3	Avg.		lbs	kg
6.06	In Range	24	25	23.8	24.3	In Range	4.88	2.21

### TEST FUEL LOADING RANGE

Allowable Residual Start-up Fuel Range (lb): 2.1 to 4.2  
 Actual Residual Start-up Fuel Weight (lb): 2.2 In Range



# LOW & MEDIUM FIRE FUEL LOAD DATA - ASTM E3053

Client: New Buck Corporation  
 Model: 74  
 Run #: 3

Job #: 19-519  
 Tracking #: 0042  
 Technician: AK  
 Date: 10/9/2019

Nominal Loading Density (lbs/ft<sup>3</sup>, wet basis): 12  
 Usable Firebox Volume (ft<sup>3</sup>): 2.15  
 Target Load Weight (lbs): 25.80  
 Total Load Weight Range (lbs): 24.51 to 27.09  
 Core Load Weight Range (lbs): 11.61 to 16.77  
 Remainder Load Weight Range (lbs): 9.03 to 14.19  
 Core Load Piece Range (lbs): 3.87 to 6.45  
 Remainder Load Piece Range (lbs): 2.58 to 7.74

### CORE LOAD DATA

Piece #	Length (in)	Weight (lbs)	Within Spec?	Fuel Piece Moisture Readings (%DB)				Within Spec?	Dry Weight	
				1	2	3	Ave.		lbs	kg
1		4.60	In Range	27.1	24.3	26.2	25.9	In Range	3.65	1.66
2		4.63	In Range	18.2	20.5	18.4	19.0	In Range	3.89	1.76
3		5.11	In Range	27.9	24.2	25.3	25.8	In Range	4.06	1.84
Core Load Wt. (lbs)		14.34	In Range							

### REMAINDER LOAD DATA (2 to 3 Pieces)

Piece #	Length (in)	Weight (lbs)	Within Spec?	Fuel Piece Moisture Readings (%DB)				Within Spec?	Dry Weight	
				1	2	3	Ave.		lbs	kg
1		3.75	In Range	24.9	25.9	26.8	25.9	In Range	2.98	1.35
2		6.44	In Range	28.0	22.9	24.7	25.2	In Range	5.14	2.33
3			NA				NA	NA	NA	NA
Remainder Load (lbs)		10.19	In Range							

Remainder Load Small/Large Piece Weight Ratio: 58% In Range ≤ 67%  
 Total Load Weight (lbs): 24.53 In Range  
 Core Load % of Total Weight: 58% In Range 45-65%  
 Remainder % of Total Weight: 42% In Range 35-55%  
 Total Load % of Target Weight: 95% In Range 95-105%  
 Actual Fuel Loading Density (lb/ft<sup>3</sup>): 11.4  
 Total Load Average Moisture Content (%DB): 24.3 In Range 19-25%  
 Total Load Average Moisture Content (%WB): 19.6  
 Total Test Load Weight (dry basis): 19.73 lbs 8.95 kg

### TEST FUEL LOADING RANGE

Allowable Charcoal Bed Weight Range (lb): 2.50 to 4.9  
 Actual Charcoal Bed Wt. (lb): 2.6 In Range

### TEST END POINT

Actual Fuel Load Ending Weight (lb): 0.1 Valid Test (≥90%)

Total Fuel Burned During Test Run:  
 24.4 lbs, wet basis  
 19.6 lbs, dry basis  
 8.90 kg, dry basis

## DILUTION TUNNEL & MISC. DATA - ASTM E3053 / E2515

Client: **New Buck Corporation**  
 Model: **74**  
 Run #: **3**  
 Test Start Time: **12:51**  
 Test Type: **Medium Fire**

Job #: **19-519**  
 Tracking #: **0042**  
 Technician: **AK**  
 Date: **10/9/2019**

Recording Interval (min): **1**  
 Total Sampling Time (min): **465**

	Pre-Test	Post Test	Avg.
Barometric Pressure (in. Hg)	30.14	30.29	30.22
Relative Humidity (%)	38.6	26.8	
Room Air Velocity (ft/min)	0	0	
Scale Audit (lbs)	20.0	20.0	
Ambient Sample Volume:			ft <sup>3</sup>

Meter Box  $\gamma$  Factor: **0.999** (A)  
 Meter Box  $\gamma$  Factor: **0.996** (B)  
 Meter Box  $\gamma$  Factor: (Ambient)

Induced Draft Check (in. H<sub>2</sub>O): **0**  
 Smoke Capture Check (%): **100%**  
 Date Flue Pipe Last Cleaned: **10/7/2019**

**Sample Train Post-Test Leak Checks**

(A)	0.002	cfm @	-9	in. Hg
(B)	0.000	cfm @	-9	in. Hg
(Ambient)		cfm @		in. Hg

### DILUTION TUNNEL FLOW

**Traverse Data**

Point	dP (in H <sub>2</sub> O)	Temp (°F)
1	0.064	115
2	0.098	115
3	0.086	115
4	0.054	115
5	0.072	115
6	0.084	115
7	0.080	115
8	0.058	115
Center	0.098	115

Dilution Tunnel H<sub>2</sub>O: **2.00** percent  
 Tunnel Diameter: **6** inches  
 Pitot Tube Cp: **0.99** [unitless]  
 Dilution Tunnel MW(dry): **29.00** lb/lb-mole  
 Dilution Tunnel MW(wet): **28.78** lb/lb-mole  
 Tunnel Area: **0.1963** ft<sup>2</sup>

V<sub>strav</sub>: **19.04** ft/sec  
 V<sub>scent</sub>: **21.58** ft/sec  
 F<sub>p</sub>: **0.883** [ratio]

Initial Tunnel Flow: **200.1** scf/min

Static Pressure: **-0.280** in. H<sub>2</sub>O

### TEST FUEL PROPERTIES

**ASTM 3053-17 - Table A1.1 Fuel Properties by Fuel Species**

Select Fuel Type	Species	%C	%H	%O	%Ash	MJ/kg	BTU/lb
	Ash, White	49.70	6.90	43.00	0.30	20.75	8927
	Beech	48.70	5.80	44.70	0.60	18.80	8088
	Birch, Sweet	49.80	6.50	43.40	0.30	20.12	8656
	Birch, Yellow	49.80	6.50	43.40	0.30	20.12	8656
	Doug Fir (Coast, Interior West/North)	48.73	6.87	43.90	0.50	19.81	8522
	Doug Fir (Interior South)	48.73	6.87	43.90	0.50	19.81	8522
	Elm, Rock	50.40	6.60	42.30	0.70	20.49	8815
	Elm, Soft	50.40	6.60	42.30	0.70	20.49	8815
	Gum, Red	50.88	6.06	41.57	1.28	19.72	8478
	Larch, Western	50.54	6.36	42.40	0.70	17.58	7558
X	Maple, Hard	50.64	6.02	41.74	1.35	19.96	8587
	Maple, Sugar	50.64	6.02	41.74	1.35	19.96	8587
	Oak, Red	49.50	6.62	43.70	0.20	20.20	8690
	Oak, White	50.40	6.59	42.70	0.20	20.50	8819
	Pine, Southern	52.60	7.00	40.10	1.31	22.30	9587
	Pine, Southern Long Leaf	52.60	7.02	40.10	1.30	22.30	9594



# BOX A TEST DATA - ASTM E3053 / ASTM E2515

Client: New Buck CorporationJob #: 19-519Model: 74Tracking #: 0042Run #: 3Technician: AKDate: 10/9/2019

Elapsed Time (min)	Particulate Sampling Data							Fuel Weight (lb)		Temperature Data (°F)			
	Gas Meter (ft <sup>3</sup> )	Sample Rate (cfm)	Dilution Tunnel dP (in H <sub>2</sub> O)	Orifice dH (in H <sub>2</sub> O)	Meter Temp (°F)	Meter Vacuum (in Hg)	Pro. Rate (%)	Scale Reading	Weight Change	Dilution Tunnel	Flue	Filter	Ambient
0	0.000		0.094	0.01	90	-0.07		24.3		105	348	85	68
1	0.147	0.147	0.090	2.10	90	-2.79	112	24.3	-0.03	138	302	85	69
2	0.293	0.146	0.094	2.08	90	0	106	24.3	-0.02	108	296	85	69
3	0.440	0.146	0.093	2.08	91	0	107	24.2	-0.05	116	352	85	69
4	0.584	0.144	0.092	2.03	91	0	107	23.9	-0.3	127	470	85	68
5	0.730	0.146	0.089	2.07	91	0	111	23.5	-0.4	134	538	85	69
6	0.876	0.146	0.092	2.08	92	0	109	23.2	-0.3	130	557	85	69
7	1.019	0.143	0.090	2.01	92	-0.56	108	22.8	-0.4	131	565	85	69
8	1.164	0.145	0.093	2.04	92	-0.65	107	22.5	-0.3	132	574	85	70
9	1.307	0.143	0.090	2.00	93	-3.92	108	22.1	-0.4	132	579	84	70
10	1.470	0.163	0.095	2.07	93	-2.01	120	21.7	-0.36	135	585	84	69
11	1.621	0.152	0.091	2.21	93	0	113	21.5	-0.24	122	547	83	68
12	1.769	0.148	0.093	2.11	94	-1.71	108	21.3	-0.2	118	517	84	69
13	1.916	0.147	0.093	2.10	94	0	108	21.0	-0.3	117	499	84	69
14	2.063	0.147	0.094	2.09	94	-0.85	107	20.8	-0.2	116	486	84	69
15	2.209	0.146	0.095	2.07	95	-1.5	105	20.6	-0.2	114	479	84	68
16	2.355	0.146	0.094	2.08	95	0	106	20.4	-0.2	114	474	84	69
17	2.501	0.146	0.094	2.08	95	-2.69	106	20.2	-0.2	114	473	84	70
18	2.648	0.147	0.093	2.10	96	-0.96	107	20.0	-0.24	114	472	84	69
19	2.795	0.147	0.093	2.10	96	0	107	19.7	-0.26	114	473	84	70
20	2.922	0.126	0.094	2.08	96	-0.34	91	19.5	-0.2	114	471	84	70
21	3.088	0.166	0.094	2.08	96	-0.68	120	19.4	-0.1	114	471	84	70
22	3.233	0.145	0.095	2.06	97	-2.69	104	19.0	-0.4	114	472	84	69
23	3.379	0.145	0.094	2.06	97	-1.06	105	19.0	0	114	468	84	68
24	3.524	0.145	0.094	2.06	97	0	105	18.7	-0.3	113	467	84	68
25	3.670	0.145	0.095	2.06	97	0	104	18.4	-0.26	114	467	84	69
26	3.815	0.145	0.093	2.06	98	-2.26	105	18.2	-0.24	113	466	84	69
27	3.960	0.145	0.093	2.06	98	-2.55	105	18.0	-0.18	112	468	84	69
28	4.106	0.146	0.094	2.07	98	0	105	17.9	-0.12	113	467	84	69
29	4.251	0.145	0.094	2.05	98	-0.43	104	17.6	-0.3	112	466	84	69
30	4.396	0.145	0.095	2.04	98	-0.87	103	17.4	-0.2	112	466	84	69
31	4.541	0.145	0.091	2.05	98	-0.88	106	17.2	-0.2	111	465	84	69
32	4.685	0.144	0.095	2.03	98	-0.09	103	17.0	-0.18	112	464	84	69

## BOX A TEST DATA - ASTM E3053 / ASTM E2515

Client: New Buck CorporationJob #: 19-519Model: 74Tracking #: 0042Run #: 3Technician: AKDate: 10/9/2019

Elapsed Time (min)	Particulate Sampling Data							Fuel Weight (lb)		Temperature Data (°F)			
	Gas Meter (ft <sup>3</sup> )	Sample Rate (cfm)	Dilution Tunnel dP (in H <sub>2</sub> O)	Orifice dH (in H <sub>2</sub> O)	Meter Temp (°F)	Meter Vacuum (in Hg)	Pro. Rate (%)	Scale Reading	Weight Change	Dilution Tunnel	Flue	Filter	Ambient
33	4.830	0.145	0.094	2.05	98	-1.7	104	16.8	-0.22	112	464	84	69
34	4.975	0.145	0.094	2.05	98	0	104	16.6	-0.2	112	464	84	69
35	5.122	0.148	0.091	2.11	98	0	108	16.4	-0.2	112	464	84	69
36	5.269	0.147	0.094	2.09	98	-1.6	105	16.2	-0.2	112	464	84	69
37	5.416	0.147	0.094	2.09	98	-2.66	105	16.0	-0.2	112	464	83	69
38	5.563	0.147	0.093	2.09	98	-1.52	106	15.8	-0.2	112	465	83	69
39	5.710	0.148	0.092	2.11	98	-2.5	107	15.6	-0.2	112	463	83	69
40	5.856	0.146	0.092	2.07	98	-0.49	106	15.4	-0.2	112	463	83	69
41	6.002	0.146	0.093	2.08	98	-1.7	106	15.2	-0.2	112	462	83	69
42	6.149	0.146	0.092	2.08	98	-1.54	106	15.0	-0.2	112	461	83	69
43	6.293	0.145	0.094	2.05	98	-2.58	104	14.8	-0.2	111	459	83	69
44	6.440	0.147	0.095	2.09	98	-2.3	105	14.6	-0.2	111	458	83	69
45	6.586	0.146	0.093	2.07	98	0	105	14.4	-0.2	111	457	83	69
46	6.732	0.146	0.096	2.08	98	-1.31	104	14.2	-0.2	110	456	83	69
47	6.878	0.146	0.094	2.07	98	-0.08	105	14.0	-0.2	111	455	83	69
48	7.024	0.146	0.096	2.07	98	-2.43	104	13.9	-0.12	110	453	83	69
49	7.170	0.146	0.094	2.08	98	0	105	13.6	-0.26	110	452	83	68
50	7.316	0.145	0.095	2.06	98	-2.15	104	13.5	-0.12	110	450	83	69
51	7.461	0.145	0.095	2.06	98	0	104	13.3	-0.2	109	449	83	69
52	7.607	0.146	0.096	2.07	98	-2.58	104	13.1	-0.16	109	449	83	69
53	7.752	0.145	0.096	2.04	98	0	103	12.9	-0.24	108	449	83	69
54	7.897	0.145	0.095	2.05	98	-0.75	103	12.8	-0.1	108	448	83	68
55	8.042	0.146	0.096	2.07	98	-2.53	103	12.6	-0.2	108	447	83	69
56	8.188	0.146	0.095	2.07	98	-0.6	104	12.4	-0.2	107	446	83	69
57	8.334	0.145	0.095	2.06	98	-2.7	104	12.2	-0.2	107	445	83	68
58	8.479	0.146	0.097	2.07	98	-0.01	103	12.1	-0.1	108	445	83	68
59	8.624	0.145	0.094	2.05	98	0	104	11.9	-0.2	107	445	84	69
60	8.771	0.146	0.095	2.08	98	-0.83	104	11.7	-0.2	107	443	84	68
61	8.918	0.148	0.091	2.11	98	-1.64	107	11.5	-0.2	106	442	84	69
62	9.066	0.148	0.097	2.12	98	0	104	11.4	-0.1	107	441	85	68
63	9.214	0.148	0.095	2.12	98	0	105	11.2	-0.2	107	439	85	69
64	9.361	0.147	0.093	2.10	98	-1.99	106	11.0	-0.2	108	439	86	69
65	9.508	0.147	0.096	2.09	98	-0.48	104	10.9	-0.14	107	437	86	69

## BOX A TEST DATA - ASTM E3053 / ASTM E2515

Client: New Buck CorporationJob #: 19-519Model: 74Tracking #: 0042Run #: 3Technician: AKDate: 10/9/2019

Elapsed Time (min)	Particulate Sampling Data							Fuel Weight (lb)		Temperature Data (°F)			
	Gas Meter (ft <sup>3</sup> )	Sample Rate (cfm)	Dilution Tunnel dP (in H <sub>2</sub> O)	Orifice dH (in H <sub>2</sub> O)	Meter Temp (°F)	Meter Vacuum (in Hg)	Pro. Rate (%)	Scale Reading	Weight Change	Dilution Tunnel	Flue	Filter	Ambient
66	9.656	0.148	0.095	2.11	98	0	105	10.7	-0.16	107	435	87	69
67	9.802	0.147	0.093	2.09	99	-2.42	105	10.5	-0.2	106	433	87	69
68	9.948	0.145	0.096	2.06	99	-0.83	103	10.3	-0.2	106	431	87	69
69	10.095	0.148	0.095	2.11	99	-2.2	105	10.2	-0.1	106	431	87	69
70	10.242	0.147	0.093	2.10	99	-0.25	106	10.0	-0.2	106	429	87	69
71	10.388	0.146	0.095	2.07	99	-2.31	103	9.8	-0.2	105	428	87	70
72	10.536	0.148	0.096	2.12	100	-2.56	104	9.7	-0.1	106	427	86	70
73	10.682	0.146	0.094	2.07	100	-1.25	104	9.5	-0.2	105	426	86	70
74	10.828	0.146	0.097	2.08	100	-0.26	103	9.4	-0.1	105	424	86	69
75	10.975	0.147	0.096	2.09	100	-2.39	103	9.2	-0.2	105	423	86	69
76	11.122	0.147	0.095	2.09	100	-1.73	104	9.1	-0.1	105	422	86	69
77	11.268	0.146	0.093	2.08	101	0	105	8.9	-0.2	105	423	86	70
78	11.414	0.146	0.094	2.07	101	0	104	8.8	-0.1	104	422	85	69
79	11.561	0.147	0.091	2.09	101	-2.55	106	8.6	-0.2	104	421	85	70
80	11.706	0.145	0.095	2.05	101	0	102	8.5	-0.1	103	419	85	70
81	11.852	0.147	0.094	2.09	101	-0.55	104	8.3	-0.18	104	418	85	69
82	11.998	0.145	0.097	2.06	101	-2.51	102	8.2	-0.12	104	416	85	70
83	12.144	0.146	0.096	2.08	101	-2.49	103	8.1	-0.1	104	414	85	70
84	12.290	0.146	0.095	2.07	102	0	103	8.0	-0.1	102	410	86	70
85	12.435	0.145	0.095	2.05	102	0	102	7.8	-0.2	102	407	86	70
86	12.581	0.147	0.096	2.09	102	-0.31	103	7.7	-0.1	101	404	86	70
87	12.728	0.146	0.095	2.08	102	0	103	7.6	-0.1	102	400	86	70
88	12.873	0.145	0.097	2.06	102	0	101	7.5	-0.1	102	396	86	70
89	13.018	0.145	0.097	2.05	102	-0.8	101	7.4	-0.1	101	393	87	70
90	13.164	0.145	0.093	2.06	102	-0.97	103	7.3	-0.1	100	390	86	70
91	13.309	0.145	0.094	2.06	103	-0.98	103	7.1	-0.2	101	390	86	70
92	13.454	0.145	0.094	2.05	103	-2.45	102	7.1	0	101	389	86	70
93	13.599	0.145	0.094	2.06	103	-2.66	103	6.9	-0.2	101	388	86	70
94	13.744	0.145	0.095	2.04	103	-2.65	101	6.8	-0.1	100	385	86	70
95	13.889	0.145	0.095	2.05	103	0	102	6.8	0	99	382	86	69
96	14.034	0.145	0.094	2.06	103	-2.73	103	6.7	-0.1	100	379	85	69
97	14.179	0.145	0.096	2.05	103	-0.18	101	6.7	0	99	376	85	69
98	14.324	0.145	0.096	2.05	103	-0.22	101	6.6	-0.1	98	373	85	68

## BOX A TEST DATA - ASTM E3053 / ASTM E2515

Client: New Buck CorporationJob #: 19-519Model: 74Tracking #: 0042Run #: 3Technician: AKDate: 10/9/2019

Elapsed Time (min)	Particulate Sampling Data							Fuel Weight (lb)		Temperature Data (°F)			
	Gas Meter (ft <sup>3</sup> )	Sample Rate (cfm)	Dilution Tunnel dP (in H <sub>2</sub> O)	Orifice dH (in H <sub>2</sub> O)	Meter Temp (°F)	Meter Vacuum (in Hg)	Pro. Rate (%)	Scale Reading	Weight Change	Dilution Tunnel	Flue	Filter	Ambient
99	14.469	0.145	0.093	2.05	103	-2.57	103	6.5	-0.1	99	371	85	68
100	14.615	0.145	0.097	2.06	104	-0.79	101	6.4	-0.1	98	369	85	69
101	14.759	0.145	0.095	2.04	104	0	101	6.3	-0.1	98	367	85	68
102	14.905	0.145	0.098	2.06	104	0	100	6.2	-0.1	97	366	85	69
103	15.050	0.145	0.098	2.06	104	-0.91	100	6.1	-0.1	98	363	85	68
104	15.195	0.145	0.097	2.05	104	-2.3	100	5.9	-0.2	97	361	86	69
105	15.340	0.145	0.095	2.04	104	-2.81	101	5.9	0	97	359	86	70
106	15.485	0.145	0.092	2.05	104	-1.82	103	5.8	-0.1	97	358	86	69
107	15.630	0.145	0.095	2.05	104	-0.04	101	5.8	-0.02	96	356	86	68
108	15.775	0.145	0.096	2.05	104	-0.35	101	5.7	-0.08	96	353	86	69
109	15.920	0.145	0.098	2.06	104	-0.9	100	5.5	-0.2	97	352	86	69
110	16.065	0.145	0.096	2.04	104	-0.92	100	5.5	0	96	349	86	70
111	16.210	0.145	0.101	2.05	104	-0.87	98	5.5	0	96	346	86	69
112	16.355	0.145	0.096	2.05	104	-0.04	101	5.4	-0.1	95	343	85	69
113	16.499	0.144	0.098	2.03	104	-2.28	99	5.3	-0.1	96	340	85	69
114	16.645	0.146	0.097	2.07	104	0	101	5.2	-0.1	95	338	85	69
115	16.789	0.144	0.095	2.03	104	-0.97	100	5.2	0	95	336	85	70
116	16.933	0.144	0.096	2.03	105	-0.22	100	5.1	-0.1	95	335	85	69
117	17.078	0.145	0.096	2.04	105	-0.75	100	5.1	0	95	332	84	70
118	17.223	0.145	0.097	2.05	105	0	100	5.0	-0.1	95	330	84	69
119	17.367	0.145	0.096	2.04	105	0	100	5.0	0	94	327	85	70
120	17.512	0.145	0.097	2.05	105	-2.56	100	4.9	-0.1	94	323	85	70
121	17.656	0.144	0.098	2.03	105	-0.47	99	4.8	-0.1	94	320	85	70
122	17.800	0.144	0.095	2.03	105	-1.41	100	4.8	0	94	317	86	70
123	17.945	0.145	0.096	2.04	105	-0.17	100	4.8	0	94	313	86	70
124	18.091	0.146	0.099	2.07	105	-2.03	99	4.7	-0.1	93	311	86	70
125	18.235	0.144	0.098	2.03	105	-2.48	99	4.7	-0.04	93	307	86	70
126	18.380	0.145	0.094	2.04	105	-2.7	101	4.6	-0.06	93	305	86	71
127	18.523	0.143	0.099	2.01	105	0	98	4.5	-0.1	93	302	86	70
128	18.667	0.145	0.096	2.04	105	0	100	4.5	0	93	300	86	70
129	18.812	0.145	0.097	2.05	105	0	100	4.4	-0.1	93	297	86	71
130	18.958	0.145	0.096	2.06	105	-0.21	100	4.4	0	92	295	85	71
131	19.102	0.145	0.097	2.04	105	0	99	4.4	-0.04	92	293	85	71

## BOX A TEST DATA - ASTM E3053 / ASTM E2515

Client: New Buck CorporationJob #: 19-519Model: 74Tracking #: 0042Run #: 3Technician: AKDate: 10/9/2019

Elapsed Time (min)	Particulate Sampling Data							Fuel Weight (lb)		Temperature Data (°F)			
	Gas Meter (ft <sup>3</sup> )	Sample Rate (cfm)	Dilution Tunnel dP (in H <sub>2</sub> O)	Orifice dH (in H <sub>2</sub> O)	Meter Temp (°F)	Meter Vacuum (in Hg)	Pro. Rate (%)	Scale Reading	Weight Change	Dilution Tunnel	Flue	Filter	Ambient
132	19.247	0.144	0.096	2.03	105	-0.37	100	4.3	-0.06	92	291	85	71
133	19.390	0.144	0.097	2.02	105	-2.65	99	4.3	0	92	289	85	71
134	19.535	0.145	0.097	2.04	105	-2.32	99	4.2	-0.1	92	287	84	70
135	19.679	0.145	0.098	2.04	105	-0.18	99	4.2	0	92	285	84	71
136	19.824	0.145	0.097	2.04	105	0	99	4.1	-0.1	92	281	84	70
137	19.966	0.142	0.096	1.99	105	-0.95	98	4.1	0	91	279	85	70
138	20.111	0.145	0.097	2.05	105	-0.7	99	4.0	-0.1	91	276	85	71
139	20.257	0.146	0.097	2.07	105	-1.83	100	4.0	0	91	273	85	71
140	20.404	0.146	0.098	2.08	105	-2.78	100	4.0	0	91	271	85	71
141	20.550	0.147	0.097	2.09	106	-2.41	100	4.0	0	91	271	86	71
142	20.697	0.147	0.096	2.09	106	0	101	3.9	-0.1	90	270	86	71
143	20.844	0.148	0.098	2.11	106	0	100	3.9	0	90	269	86	71
144	20.989	0.145	0.097	2.05	106	-0.14	99	3.8	-0.1	90	268	86	71
145	21.135	0.146	0.096	2.07	106	-2.8	100	3.8	0	90	267	86	71
146	21.281	0.146	0.099	2.07	106	-2.6	99	3.7	-0.1	90	267	86	71
147	21.427	0.146	0.099	2.07	106	-0.18	99	3.7	0	89	265	85	71
148	21.573	0.146	0.099	2.07	106	0	99	3.7	0	89	264	85	71
149	21.720	0.147	0.099	2.09	106	-2.5	99	3.7	0	89	263	85	71
150	21.865	0.145	0.098	2.05	106	-0.65	99	3.6	-0.1	89	260	85	71
151	22.010	0.146	0.096	2.07	106	-2.24	100	3.6	0	89	259	84	71
152	22.155	0.145	0.097	2.05	106	0	99	3.6	0	89	257	84	71
153	22.301	0.145	0.097	2.06	106	-2.83	99	3.6	0	88	254	84	71
154	22.447	0.146	0.095	2.07	106	-1.65	101	3.6	0	88	253	84	71
155	22.593	0.146	0.095	2.07	106	0	101	3.5	-0.1	88	251	84	71
156	22.738	0.145	0.096	2.06	106	0	100	3.5	0	89	249	85	71
157	22.884	0.146	0.094	2.08	106	-1	101	3.5	0	88	248	85	71
158	23.030	0.145	0.095	2.06	106	-2.65	100	3.4	-0.1	88	246	85	71
159	23.177	0.147	0.099	2.10	106	0	99	3.4	0	88	245	86	71
160	23.323	0.146	0.099	2.07	106	0	99	3.4	0	88	244	86	71
161	23.469	0.146	0.095	2.08	106	0	101	3.4	0	88	242	86	71
162	23.614	0.145	0.098	2.05	106	-2.36	99	3.4	0	88	242	86	71
163	23.759	0.145	0.098	2.05	106	-0.17	99	3.4	-0.02	88	239	86	71
164	23.904	0.145	0.098	2.05	106	-2.09	99	3.3	-0.08	88	239	85	71



## BOX A TEST DATA - ASTM E3053 / ASTM E2515

Client: New Buck CorporationJob #: 19-519Model: 74Tracking #: 0042Run #: 3Technician: AKDate: 10/9/2019

Elapsed Time (min)	Particulate Sampling Data							Fuel Weight (lb)		Temperature Data (°F)			
	Gas Meter (ft <sup>3</sup> )	Sample Rate (cfm)	Dilution Tunnel dP (in H <sub>2</sub> O)	Orifice dH (in H <sub>2</sub> O)	Meter Temp (°F)	Meter Vacuum (in Hg)	Pro. Rate (%)	Scale Reading	Weight Change	Dilution Tunnel	Flue	Filter	Ambient
165	24.050	0.146	0.094	2.07	106	-2.75	101	3.2	-0.1	88	238	85	71
166	24.197	0.147	0.096	2.10	106	-0.74	101	3.2	0	88	237	85	71
167	24.342	0.145	0.099	2.06	106	-0.27	98	3.2	0	87	236	85	71
168	24.487	0.145	0.097	2.05	106	-0.19	99	3.2	0	87	236	85	71
169	24.634	0.146	0.097	2.08	106	-2.42	100	3.2	0	88	235	84	71
170	24.779	0.145	0.095	2.06	106	-1.83	100	3.2	0	87	235	84	71
171	24.925	0.146	0.098	2.08	106	0	99	3.2	0	87	234	84	71
172	25.071	0.145	0.099	2.06	106	-2.69	98	3.2	0	87	233	84	71
173	25.217	0.146	0.100	2.08	106	-2.02	98	3.1	-0.1	87	232	85	72
174	25.363	0.146	0.096	2.07	106	0	100	3.1	0	87	231	85	70
175	25.508	0.145	0.098	2.06	106	0	99	3.1	0	87	231	85	70
176	25.654	0.145	0.097	2.06	106	-2.76	99	3.1	0	87	230	86	70
177	25.800	0.146	0.096	2.08	106	-1.89	100	3.1	0	86	229	86	71
178	25.946	0.146	0.098	2.07	106	-1.2	99	3.0	-0.1	86	227	86	70
179	26.092	0.146	0.097	2.07	106	-2.14	99	3.0	0	86	227	86	71
180	26.237	0.145	0.098	2.06	106	-0.46	99	3.0	0	85	225	85	71
181	26.383	0.146	0.098	2.08	106	0	99	3.0	0	85	224	85	70
182	26.529	0.146	0.097	2.07	106	-2.89	99	3.0	-0.04	85	223	85	71
183	26.675	0.146	0.097	2.07	106	0	99	2.9	-0.06	85	222	85	70
184	26.821	0.146	0.099	2.07	106	0	98	2.9	0	85	221	84	70
185	26.967	0.147	0.098	2.09	106	0	99	2.9	0	85	220	84	71
186	27.114	0.146	0.099	2.08	106	-2.74	99	2.9	0	85	218	84	70
187	27.260	0.146	0.095	2.08	106	0	101	2.8	-0.1	84	217	84	70
188	27.406	0.146	0.100	2.08	106	-2.54	98	2.8	0	84	216	84	70
189	27.553	0.147	0.099	2.10	106	-2.53	99	2.8	0	84	216	84	70
190	27.700	0.146	0.096	2.08	106	-1.57	100	2.8	0	84	215	85	70
191	27.845	0.145	0.097	2.05	106	-2.78	99	2.8	0	84	213	85	70
192	27.991	0.146	0.097	2.07	106	-1.41	99	2.8	0	84	212	85	70
193	28.136	0.145	0.098	2.06	106	-1.97	98	2.8	0	84	212	85	70
194	28.282	0.146	0.101	2.08	106	-2.31	98	2.8	0	84	211	86	71
195	28.427	0.145	0.096	2.05	106	-1.64	99	2.8	0	84	210	85	71
196	28.572	0.145	0.097	2.05	106	-2.75	99	2.8	0	84	210	85	71
197	28.717	0.145	0.097	2.04	106	0	98	2.8	0	84	209	85	71

## BOX A TEST DATA - ASTM E3053 / ASTM E2515

Client: New Buck CorporationJob #: 19-519Model: 74Tracking #: 0042Run #: 3Technician: AKDate: 10/9/2019

Elapsed Time (min)	Particulate Sampling Data							Fuel Weight (lb)		Temperature Data (°F)			
	Gas Meter (ft <sup>3</sup> )	Sample Rate (cfm)	Dilution Tunnel dP (in H <sub>2</sub> O)	Orifice dH (in H <sub>2</sub> O)	Meter Temp (°F)	Meter Vacuum (in Hg)	Pro. Rate (%)	Scale Reading	Weight Change	Dilution Tunnel	Flue	Filter	Ambient
198	28.864	0.147	0.099	2.10	106	0	99	2.7	-0.08	84	208	85	71
199	29.011	0.147	0.101	2.09	105	-0.86	98	2.8	0.08	84	207	85	70
200	29.156	0.146	0.099	2.07	105	0	98	2.7	-0.1	84	207	84	69
201	29.303	0.147	0.098	2.09	105	-1.94	100	2.7	0	84	206	84	70
202	29.449	0.146	0.095	2.07	105	-1.48	100	2.7	0	84	206	84	70
203	29.595	0.146	0.096	2.08	105	-2.15	100	2.7	0	84	205	84	70
204	29.741	0.146	0.096	2.07	105	0	100	2.7	0	83	204	84	70
205	29.887	0.146	0.099	2.07	105	-2.67	98	2.6	-0.1	84	203	84	70
206	30.034	0.148	0.098	2.11	105	-1.69	100	2.6	0.04	84	202	84	70
207	30.181	0.146	0.099	2.08	105	-2.6	99	2.6	-0.04	84	202	85	71
208	30.327	0.146	0.098	2.07	105	-2.2	99	2.6	0	84	202	85	70
209	30.474	0.147	0.097	2.10	105	-2.3	100	2.6	0	84	200	85	70
210	30.620	0.147	0.100	2.09	105	-0.81	99	2.6	0	84	200	85	70
211	30.767	0.147	0.096	2.09	105	-1.95	101	2.5	-0.1	84	199	85	70
212	30.915	0.148	0.096	2.11	105	0	101	2.5	0	84	199	85	70
213	31.061	0.147	0.098	2.09	105	-2.79	100	2.5	0	84	198	85	71
214	31.209	0.148	0.100	2.11	105	0	99	2.5	0	83	197	85	71
215	31.355	0.146	0.099	2.07	105	-2.65	98	2.5	0	84	197	85	71
216	31.501	0.146	0.099	2.08	105	-0.29	99	2.5	0	83	197	85	70
217	31.647	0.146	0.099	2.07	105	0	98	2.5	0	84	196	84	70
218	31.793	0.146	0.097	2.08	105	-0.59	100	2.4	-0.1	84	196	84	71
219	31.940	0.147	0.100	2.09	105	-1.92	99	2.4	0	84	196	84	70
220	32.085	0.145	0.100	2.06	105	-2.8	98	2.4	0	84	195	84	70
221	32.232	0.147	0.098	2.09	105	-2.72	100	2.4	0	84	195	84	71
222	32.379	0.147	0.098	2.09	105	-2.64	100	2.4	0	84	194	84	70
223	32.525	0.146	0.098	2.08	105	-1.18	99	2.4	0	84	194	85	70
224	32.671	0.146	0.097	2.07	105	0	99	2.4	0	84	194	85	70
225	32.817	0.146	0.098	2.08	105	0	99	2.4	0	83	194	85	71
226	32.962	0.145	0.099	2.05	105	-1.27	98	2.4	0	83	193	86	71
227	33.107	0.145	0.097	2.06	105	-0.18	99	2.3	-0.1	83	193	86	71
228	33.253	0.146	0.099	2.07	105	-0.21	98	2.3	0	83	192	86	71
229	33.400	0.147	0.097	2.09	105	-1.28	100	2.3	0	83	191	85	71
230	33.546	0.146	0.099	2.07	105	-2.22	98	2.3	0	83	192	85	71

## BOX A TEST DATA - ASTM E3053 / ASTM E2515

Client: New Buck CorporationJob #: 19-519Model: 74Tracking #: 0042Run #: 3Technician: AKDate: 10/9/2019

Elapsed Time (min)	Particulate Sampling Data							Fuel Weight (lb)		Temperature Data (°F)			
	Gas Meter (ft <sup>3</sup> )	Sample Rate (cfm)	Dilution Tunnel dP (in H <sub>2</sub> O)	Orifice dH (in H <sub>2</sub> O)	Meter Temp (°F)	Meter Vacuum (in Hg)	Pro. Rate (%)	Scale Reading	Weight Change	Dilution Tunnel	Flue	Filter	Ambient
231	33.692	0.146	0.098	2.07	105	-0.38	99	2.3	0	84	191	85	71
232	33.837	0.145	0.099	2.06	105	-2.66	98	2.3	0	84	191	85	71
233	33.983	0.146	0.099	2.08	105	0	99	2.2	-0.1	83	191	85	71
234	34.129	0.146	0.099	2.07	105	-0.94	98	2.3	0.1	83	191	84	71
235	34.275	0.145	0.100	2.06	105	-2.42	98	2.2	-0.1	84	191	84	71
236	34.420	0.146	0.097	2.07	105	0	99	2.2	0	84	190	84	71
237	34.567	0.147	0.097	2.09	105	-0.31	100	2.2	0	83	190	84	71
238	34.713	0.145	0.098	2.06	105	-2.39	99	2.2	0	83	190	84	71
239	34.858	0.146	0.099	2.07	105	-2.18	98	2.2	0	83	190	84	71
240	35.004	0.145	0.100	2.06	105	0	98	2.1	-0.1	83	189	85	71
241	35.151	0.147	0.099	2.09	105	-2.83	99	2.1	0	83	189	85	71
242	35.298	0.147	0.098	2.10	105	-2.53	100	2.1	0	83	188	85	71
243	35.443	0.145	0.101	2.06	105	0	97	2.1	0	82	188	85	71
244	35.590	0.147	0.100	2.09	105	0	98	2.1	0	83	188	85	71
245	35.735	0.145	0.099	2.05	105	-2.83	98	2.1	0	83	188	85	72
246	35.881	0.146	0.098	2.08	105	-1.95	99	2.1	0	83	187	85	71
247	36.027	0.146	0.097	2.07	105	-0.85	99	2.1	0	83	187	85	71
248	36.172	0.145	0.097	2.05	105	-1.54	99	2.0	-0.1	83	186	85	71
249	36.317	0.145	0.097	2.05	105	0	99	2.1	0.08	82	186	85	71
250	36.463	0.146	0.099	2.08	105	0	99	2.0	-0.08	83	186	84	71
251	36.609	0.145	0.098	2.06	105	0	98	2.0	0	82	185	84	71
252	36.754	0.145	0.098	2.06	105	0	98	2.0	0	82	186	84	71
253	36.900	0.146	0.098	2.07	105	-0.22	99	2.0	0	82	186	84	71
254	37.045	0.145	0.097	2.05	105	-0.65	99	2.0	0	82	185	84	71
255	37.189	0.145	0.097	2.04	105	0	98	2.0	-0.02	82	185	84	71
256	37.335	0.145	0.100	2.06	105	-2.76	97	1.9	-0.08	82	185	84	71
257	37.481	0.146	0.099	2.07	105	-1.4	98	1.9	0	83	184	85	71
258	37.627	0.146	0.098	2.07	105	-0.08	99	1.9	0	83	185	85	71
259	37.772	0.146	0.096	2.07	105	-0.74	100	1.9	0	82	184	85	71
260	37.919	0.146	0.098	2.08	104	-2.32	99	1.9	0	83	184	85	71
261	38.065	0.146	0.098	2.07	105	-2.42	99	1.8	-0.08	82	184	85	71
262	38.210	0.145	0.101	2.06	104	-1.32	97	1.8	0.02	83	184	85	71
263	38.356	0.146	0.101	2.07	104	-0.19	97	1.8	-0.04	82	184	85	71

## BOX A TEST DATA - ASTM E3053 / ASTM E2515

Client: New Buck CorporationJob #: 19-519Model: 74Tracking #: 0042Run #: 3Technician: AKDate: 10/9/2019

Elapsed Time (min)	Particulate Sampling Data							Fuel Weight (lb)		Temperature Data (°F)			
	Gas Meter (ft <sup>3</sup> )	Sample Rate (cfm)	Dilution Tunnel dP (in H <sub>2</sub> O)	Orifice dH (in H <sub>2</sub> O)	Meter Temp (°F)	Meter Vacuum (in Hg)	Pro. Rate (%)	Scale Reading	Weight Change	Dilution Tunnel	Flue	Filter	Ambient
264	38.502	0.146	0.098	2.08	104	-0.62	99	1.8	0	83	184	85	71
265	38.648	0.146	0.098	2.07	104	-1.22	99	1.8	0	83	184	85	71
266	38.794	0.146	0.099	2.07	104	0	99	1.8	0	83	184	84	72
267	38.940	0.146	0.098	2.08	104	-0.3	99	1.7	-0.08	83	184	84	72
268	39.087	0.147	0.098	2.09	104	0	100	1.7	-0.02	83	183	84	72
269	39.233	0.146	0.097	2.08	104	-1.56	100	1.7	0	83	183	84	72
270	39.379	0.146	0.095	2.08	104	-1.14	101	1.7	0	82	183	84	72
271	39.523	0.144	0.099	2.02	104	-2.13	97	1.7	0	82	183	84	71
272	39.669	0.146	0.101	2.07	104	-2.43	98	1.7	0	83	183	84	72
273	39.815	0.146	0.099	2.08	104	0	99	1.7	0	83	182	85	72
274	39.962	0.147	0.098	2.10	104	0	100	1.7	0	83	182	85	72
275	40.108	0.146	0.098	2.07	104	-2.54	99	1.7	0	82	182	85	72
276	40.254	0.146	0.097	2.08	104	-0.95	100	1.7	0	83	182	85	71
277	40.400	0.145	0.098	2.06	104	-2.11	99	1.7	0	82	181	85	71
278	40.546	0.146	0.097	2.08	104	0	100	1.7	0	82	181	85	72
279	40.692	0.146	0.098	2.07	104	-1.8	99	1.6	-0.1	82	181	85	72
280	40.839	0.147	0.097	2.09	104	-0.25	100	1.6	0	83	181	85	72
281	40.985	0.146	0.098	2.08	104	-0.43	99	1.6	0	82	181	85	72
282	41.132	0.147	0.097	2.09	104	0	100	1.6	0	82	180	84	71
283	41.277	0.145	0.098	2.06	104	-0.17	99	1.6	0	83	180	84	72
284	41.423	0.146	0.099	2.07	104	-1.27	99	1.6	0	83	180	84	72
285	41.569	0.146	0.100	2.08	104	0	98	1.5	-0.1	82	180	84	71
286	41.715	0.146	0.100	2.08	104	-2.13	98	1.5	0	82	180	84	72
287	41.861	0.145	0.099	2.06	104	-0.75	98	1.5	0	83	179	84	72
288	42.006	0.145	0.098	2.05	104	-0.15	98	1.5	0	82	179	84	72
289	42.152	0.146	0.098	2.08	104	0	99	1.5	0	83	179	85	72
290	42.297	0.145	0.097	2.06	104	-0.19	99	1.5	0	82	179	85	72
291	42.444	0.147	0.100	2.09	104	-2.59	99	1.5	-0.04	83	179	85	71
292	42.592	0.148	0.098	2.11	104	-0.35	100	1.4	-0.06	82	179	85	71
293	42.738	0.146	0.100	2.07	104	-0.96	98	1.4	0	83	179	85	71
294	42.882	0.144	0.101	2.03	104	0	96	1.4	0	82	178	85	71
295	43.027	0.145	0.097	2.06	104	0	99	1.4	0	82	178	85	71
296	43.174	0.147	0.098	2.09	104	0	99	1.4	0	82	178	85	71

## BOX A TEST DATA - ASTM E3053 / ASTM E2515

Client: New Buck Corporation  
 Model: 74  
 Run #: 3

Job #: 19-519  
 Tracking #: 0042  
 Technician: AK  
 Date: 10/9/2019

Elapsed Time (min)	Particulate Sampling Data							Fuel Weight (lb)		Temperature Data (°F)			
	Gas Meter (ft <sup>3</sup> )	Sample Rate (cfm)	Dilution Tunnel dP (in H <sub>2</sub> O)	Orifice dH (in H <sub>2</sub> O)	Meter Temp (°F)	Meter Vacuum (in Hg)	Pro. Rate (%)	Scale Reading	Weight Change	Dilution Tunnel	Flue	Filter	Ambient
297	43.321	0.147	0.097	2.09	104	0	100	1.4	0	82	178	85	71
298	43.466	0.145	0.099	2.06	104	-2.25	98	1.4	0	82	178	85	71
299	43.612	0.146	0.099	2.08	104	0	99	1.4	0	82	178	84	71
300	43.758	0.146	0.099	2.07	104	-2.72	98	1.3	-0.1	82	178	84	71
301	43.903	0.145	0.099	2.06	104	-2.62	98	1.3	0	82	177	84	72
302	44.049	0.146	0.099	2.07	104	0	98	1.3	0	82	177	84	71
303	44.195	0.146	0.100	2.07	104	-0.27	98	1.3	0	82	177	84	71
304	44.341	0.146	0.101	2.07	104	0	97	1.3	0	82	176	84	72
305	44.487	0.146	0.100	2.08	104	0	98	1.3	0	82	176	84	72
306	44.633	0.145	0.100	2.06	104	-0.4	98	1.3	0	82	176	85	71
307	44.780	0.148	0.099	2.11	104	-0.59	100	1.3	0	82	176	85	71
308	44.927	0.146	0.098	2.08	104	-2.63	99	1.3	0	82	175	85	71
309	45.072	0.146	0.098	2.07	104	-1.41	99	1.2	-0.1	82	174	85	71
310	45.217	0.145	0.098	2.04	104	-1.76	98	1.2	0	82	174	85	71
311	45.361	0.145	0.098	2.04	104	-0.26	98	1.2	0	82	173	85	71
312	45.506	0.145	0.098	2.05	104	-0.83	98	1.2	0	82	173	85	72
313	45.653	0.147	0.100	2.09	104	0	98	1.2	0	82	173	85	71
314	45.799	0.146	0.100	2.07	104	0	98	1.2	0	82	173	85	72
315	45.945	0.146	0.098	2.08	104	-2.08	99	1.2	0	82	172	84	72
316	46.092	0.146	0.100	2.08	104	-1.97	98	1.1	-0.08	81	172	84	72
317	46.238	0.146	0.101	2.08	104	-1.3	98	1.1	-0.02	82	171	84	71
318	46.383	0.145	0.099	2.06	104	-0.81	98	1.1	0	82	170	84	71
319	46.530	0.147	0.096	2.09	104	0	101	1.1	0	82	170	84	71
320	46.676	0.146	0.101	2.07	104	-1.97	97	1.1	0	82	170	84	71
321	46.822	0.146	0.102	2.08	104	-0.93	97	1.1	0	82	170	84	71
322	46.968	0.146	0.100	2.08	104	0	98	1.1	0	82	170	84	71
323	47.114	0.145	0.097	2.06	104	-1.61	99	1.0	-0.06	82	169	85	71
324	47.259	0.145	0.098	2.06	104	-2.47	99	1.0	0	82	169	85	71
325	47.407	0.148	0.101	2.11	104	-1.55	98	1.0	-0.04	81	168	85	71
326	47.553	0.146	0.101	2.07	104	-1.05	97	1.0	0	82	168	85	72
327	47.698	0.146	0.100	2.07	104	-2.18	98	1.0	0	82	167	85	72
328	47.844	0.146	0.100	2.07	104	0	98	1.0	0	82	167	85	72
329	47.990	0.146	0.100	2.07	104	0	98	1.0	0	82	167	85	72

## BOX A TEST DATA - ASTM E3053 / ASTM E2515

Client: New Buck CorporationJob #: 19-519Model: 74Tracking #: 0042Run #: 3Technician: AKDate: 10/9/2019

Elapsed Time (min)	Particulate Sampling Data							Fuel Weight (lb)		Temperature Data (°F)			
	Gas Meter (ft <sup>3</sup> )	Sample Rate (cfm)	Dilution Tunnel dP (in H <sub>2</sub> O)	Orifice dH (in H <sub>2</sub> O)	Meter Temp (°F)	Meter Vacuum (in Hg)	Pro. Rate (%)	Scale Reading	Weight Change	Dilution Tunnel	Flue	Filter	Ambient
330	48.136	0.146	0.098	2.08	104	0	99	1.0	0	82	166	85	72
331	48.282	0.145	0.097	2.06	104	0	99	0.9	-0.1	82	166	84	72
332	48.428	0.146	0.097	2.07	104	0	99	1.0	0.1	82	165	84	72
333	48.574	0.146	0.099	2.07	104	-0.77	98	0.9	-0.1	82	165	84	72
334	48.718	0.145	0.097	2.04	104	0	99	0.9	0	82	165	84	72
335	48.863	0.145	0.098	2.05	104	-2.58	98	0.9	0	81	164	84	72
336	49.009	0.146	0.099	2.08	104	-2.73	99	0.9	0	81	164	84	71
337	49.156	0.146	0.100	2.08	104	-2.14	98	0.9	0	81	164	84	71
338	49.301	0.146	0.097	2.07	104	-2.22	99	0.9	0	82	163	84	72
339	49.446	0.145	0.098	2.05	104	-2.62	98	0.9	0	81	162	85	71
340	49.592	0.146	0.099	2.07	104	0	98	0.9	0	81	162	85	71
341	49.736	0.144	0.099	2.03	104	-1.02	97	0.9	0	81	162	85	71
342	49.881	0.145	0.098	2.05	104	-2.31	98	0.9	0	81	162	85	71
343	50.028	0.146	0.099	2.08	104	0	99	0.9	0	81	162	85	71
344	50.173	0.145	0.098	2.05	104	-1.95	98	0.8	-0.06	81	162	85	71
345	50.318	0.145	0.096	2.06	104	0	99	0.9	0.06	80	161	85	71
346	50.464	0.146	0.098	2.07	104	-2.76	99	0.8	-0.1	80	161	85	71
347	50.609	0.145	0.099	2.05	104	-1.9	98	0.8	0	81	161	84	71
348	50.755	0.146	0.099	2.07	104	0	98	0.8	0	80	161	84	71
349	50.901	0.146	0.099	2.07	104	-2.77	98	0.8	0	80	160	84	71
350	51.046	0.145	0.099	2.06	104	-0.42	98	0.8	0	80	160	84	71
351	51.191	0.145	0.098	2.05	104	0	98	0.8	0	80	159	84	71
352	51.337	0.146	0.101	2.07	104	-2.29	97	0.8	0	80	159	84	71
353	51.482	0.145	0.099	2.06	104	-1.8	98	0.8	0	80	159	84	71
354	51.628	0.146	0.096	2.07	104	0	100	0.8	0	80	159	84	71
355	51.774	0.146	0.101	2.07	104	-0.83	97	0.8	0	80	158	85	71
356	51.919	0.145	0.100	2.05	104	0	97	0.7	-0.1	80	157	85	71
357	52.064	0.145	0.100	2.06	104	-1.26	97	0.7	0	80	157	85	71
358	52.210	0.146	0.097	2.07	104	-1.64	99	0.7	0	80	156	85	71
359	52.358	0.148	0.099	2.11	104	-1.93	99	0.7	0	80	157	85	71
360	52.504	0.146	0.097	2.07	104	0	99	0.7	-0.02	79	156	85	71
361	52.650	0.146	0.098	2.08	104	0	99	0.7	0.02	79	156	85	71
362	52.796	0.146	0.101	2.08	104	0	97	0.7	0	79	156	84	71

# BOX A TEST DATA - ASTM E3053 / ASTM E2515

Client: New Buck CorporationJob #: 19-519Model: 74Tracking #: 0042Run #: 3Technician: AKDate: 10/9/2019

Elapsed Time (min)	Particulate Sampling Data							Fuel Weight (lb)		Temperature Data (°F)			
	Gas Meter (ft <sup>3</sup> )	Sample Rate (cfm)	Dilution Tunnel dP (in H <sub>2</sub> O)	Orifice dH (in H <sub>2</sub> O)	Meter Temp (°F)	Meter Vacuum (in Hg)	Pro. Rate (%)	Scale Reading	Weight Change	Dilution Tunnel	Flue	Filter	Ambient
363	52.942	0.145	0.098	2.06	104	0	98	0.6	-0.1	79	156	84	71
364	53.088	0.146	0.099	2.07	104	-0.15	98	0.6	0	79	156	84	71
365	53.233	0.145	0.100	2.06	104	-2.23	97	0.6	0	79	156	84	71
366	53.379	0.146	0.099	2.07	104	-0.01	98	0.6	0	79	155	84	70
367	53.524	0.145	0.099	2.05	104	-2.49	98	0.6	0	79	155	84	70
368	53.670	0.146	0.100	2.07	104	-2.48	98	0.6	0	79	155	84	70
369	53.815	0.145	0.101	2.06	104	-2.64	97	0.6	0	79	154	84	70
370	53.960	0.145	0.098	2.06	104	0	98	0.6	0	78	154	84	70
371	54.107	0.147	0.100	2.09	104	-2.1	98	0.6	0	79	154	84	70
372	54.252	0.145	0.097	2.04	104	0	98	0.6	0	79	154	85	70
373	54.398	0.146	0.098	2.07	104	-0.55	99	0.6	0	79	153	85	70
374	54.545	0.148	0.100	2.11	104	-2.6	99	0.5	-0.1	78	153	85	70
375	54.691	0.145	0.101	2.06	104	-0.06	97	0.5	0	78	152	85	70
376	54.837	0.147	0.097	2.09	104	-2.34	100	0.5	0	78	152	85	70
377	54.984	0.146	0.103	2.08	104	0	96	0.5	0	78	152	85	70
378	55.129	0.146	0.098	2.07	104	0	99	0.5	0	78	152	84	70
379	55.275	0.146	0.101	2.07	103	-2.6	97	0.5	0	78	151	84	70
380	55.421	0.146	0.098	2.08	103	0	99	0.5	0	77	151	84	70
381	55.568	0.147	0.096	2.09	103	-2.79	100	0.5	0	78	151	84	70
382	55.714	0.146	0.098	2.08	103	-1.37	99	0.5	0	77	150	84	70
383	55.862	0.148	0.101	2.11	103	-2.31	98	0.5	0	77	150	83	70
384	56.009	0.147	0.098	2.09	103	0	99	0.5	0	77	149	83	69
385	56.155	0.146	0.098	2.08	103	-2.66	99	0.5	0	77	149	84	70
386	56.302	0.147	0.100	2.10	103	0	99	0.5	0	77	149	84	69
387	56.449	0.147	0.099	2.09	103	-2.59	99	0.5	0	77	148	84	69
388	56.595	0.146	0.100	2.07	103	0	98	0.5	0	77	148	85	69
389	56.740	0.146	0.098	2.07	103	-0.13	99	0.4	-0.08	77	148	85	69
390	56.885	0.144	0.100	2.03	103	-1	97	0.5	0.08	77	147	85	69
391	57.030	0.146	0.098	2.07	103	-0.04	99	0.4	-0.1	77	147	85	69
392	57.176	0.146	0.102	2.07	103	-2.83	97	0.4	0	77	147	85	69
393	57.323	0.146	0.099	2.08	103	0	98	0.4	0	76	146	84	69
394	57.469	0.147	0.099	2.09	103	-2.73	99	0.4	0	76	146	84	69
395	57.615	0.146	0.103	2.07	103	-1.5	96	0.4	0	76	146	84	69

## BOX A TEST DATA - ASTM E3053 / ASTM E2515

Client: New Buck CorporationJob #: 19-519Model: 74Tracking #: 0042Run #: 3Technician: AKDate: 10/9/2019

Elapsed Time (min)	Particulate Sampling Data							Fuel Weight (lb)		Temperature Data (°F)			
	Gas Meter (ft <sup>3</sup> )	Sample Rate (cfm)	Dilution Tunnel dP (in H <sub>2</sub> O)	Orifice dH (in H <sub>2</sub> O)	Meter Temp (°F)	Meter Vacuum (in Hg)	Pro. Rate (%)	Scale Reading	Weight Change	Dilution Tunnel	Flue	Filter	Ambient
396	57.763	0.148	0.099	2.12	103	-2.09	99	0.4	0	76	145	84	69
397	57.909	0.146	0.099	2.08	103	-2.27	98	0.4	0	76	145	83	69
398	58.056	0.147	0.099	2.10	103	0	99	0.4	0	76	144	83	69
399	58.204	0.147	0.098	2.10	103	-0.19	99	0.4	0	76	144	83	69
400	58.350	0.147	0.101	2.09	103	-2.54	98	0.4	0	76	144	83	68
401	58.498	0.148	0.098	2.11	103	-2.05	100	0.3	-0.06	76	144	84	69
402	58.644	0.146	0.101	2.08	103	-2.34	97	0.4	0.06	76	143	84	68
403	58.790	0.146	0.100	2.08	103	0	98	0.3	-0.06	76	143	84	68
404	58.936	0.145	0.100	2.06	103	0	97	0.3	-0.04	75	142	85	68
405	59.083	0.148	0.101	2.11	103	0	98	0.3	0	75	142	85	68
406	59.229	0.145	0.100	2.06	103	0	97	0.3	0	75	142	85	68
407	59.375	0.146	0.101	2.08	103	-2.8	97	0.3	0	75	141	85	68
408	59.523	0.148	0.102	2.12	102	-2.71	98	0.3	0	75	141	84	68
409	59.669	0.146	0.100	2.07	102	-0.2	98	0.3	0	75	141	84	68
410	59.815	0.146	0.103	2.08	102	-2.62	96	0.3	0	75	140	84	68
411	59.960	0.145	0.098	2.05	102	0	98	0.3	0	75	140	84	68
412	60.105	0.145	0.101	2.05	102	-1.93	96	0.3	0	74	140	83	68
413	60.252	0.147	0.099	2.09	102	-2.54	99	0.3	0	74	139	83	68
414	60.398	0.146	0.099	2.07	102	0	98	0.3	0	74	139	83	68
415	60.544	0.146	0.095	2.08	102	-2.42	100	0.3	0	74	139	83	68
416	60.691	0.147	0.096	2.10	102	-2.65	101	0.3	0	75	139	84	67
417	60.837	0.146	0.100	2.07	102	-2.79	98	0.2	-0.1	74	139	84	67
418	60.983	0.146	0.101	2.08	102	-0.23	97	0.2	0	74	138	84	68
419	61.130	0.147	0.101	2.10	102	0	98	0.2	0	74	138	85	67
420	61.277	0.146	0.101	2.08	102	-1.15	97	0.2	0	74	138	85	67
421	61.424	0.147	0.100	2.10	102	-2.1	98	0.2	0	74	138	85	67
422	61.570	0.146	0.102	2.08	102	-2.05	97	0.2	0	74	138	85	67
423	61.717	0.147	0.102	2.10	102	-2.68	97	0.2	0	74	138	84	67
424	61.863	0.146	0.100	2.07	102	-0.8	98	0.2	0	74	137	84	67
425	62.009	0.146	0.103	2.08	102	0	96	0.2	0	74	137	84	67
426	62.156	0.147	0.099	2.10	102	-1.85	99	0.2	0	74	137	83	66
427	62.302	0.146	0.098	2.07	102	-1.16	99	0.2	0	74	137	83	67
428	62.448	0.146	0.102	2.08	102	0	97	0.2	-0.04	74	137	83	67



## BOX A TEST DATA - ASTM E3053 / ASTM E2515

Client: New Buck Corporation  
 Model: 74  
 Run #: 3

Job #: 19-519  
 Tracking #: 0042  
 Technician: AK  
 Date: 10/9/2019

Elapsed Time (min)	Particulate Sampling Data							Fuel Weight (lb)		Temperature Data (°F)			
	Gas Meter (ft <sup>3</sup> )	Sample Rate (cfm)	Dilution Tunnel dP (in H <sub>2</sub> O)	Orifice dH (in H <sub>2</sub> O)	Meter Temp (°F)	Meter Vacuum (in Hg)	Pro. Rate (%)	Scale Reading	Weight Change	Dilution Tunnel	Flue	Filter	Ambient
429	62.595	0.147	0.100	2.09	102	-2.88	98	0.1	-0.02	73	136	83	67
430	62.741	0.146	0.101	2.07	101	-1.54	97	0.1	-0.04	74	136	83	67
431	62.887	0.146	0.100	2.08	101	-0.18	98	0.2	0.1	73	136	83	67
432	63.033	0.146	0.102	2.07	101	-2.68	97	0.2	0	73	136	84	67
433	63.179	0.145	0.098	2.06	101	0	98	0.1	-0.1	73	136	84	67
434	63.324	0.146	0.101	2.07	101	-0.39	97	0.2	0.1	73	136	84	67
435	63.470	0.146	0.101	2.07	101	0	97	0.1	-0.1	73	135	84	67
436	63.617	0.147	0.102	2.09	101	-0.06	97	0.1	0	73	135	84	67
437	63.762	0.145	0.097	2.06	101	-0.02	99	0.1	0	73	135	84	66
438	63.909	0.146	0.100	2.08	101	0	98	0.1	0	73	135	84	67
439	64.054	0.145	0.101	2.06	101	-1.81	97	0.1	0	73	135	84	67
440	64.201	0.147	0.100	2.10	101	0	98	0.1	0	73	135	83	67
441	64.347	0.146	0.104	2.08	101	-2.67	96	0.1	0	73	135	83	67
442	64.495	0.147	0.101	2.10	101	-2.62	98	0.1	0	73	134	83	67
443	64.641	0.146	0.100	2.08	101	-1.54	98	0.1	0	73	134	83	67
444	64.788	0.148	0.100	2.11	101	0	99	0.1	0	72	134	83	67
445	64.935	0.146	0.099	2.08	101	-1.8	98	0.1	0	73	134	83	67
446	65.080	0.146	0.102	2.07	101	-1.29	97	0.1	0	72	134	83	66
447	65.227	0.146	0.103	2.08	101	0	96	0.1	0	73	133	84	66
448	65.373	0.146	0.102	2.08	101	0	97	0.1	0	73	134	84	67
449	65.520	0.147	0.101	2.10	101	-0.17	98	0.1	0	72	134	84	66
450	65.667	0.147	0.100	2.10	101	-0.93	98	0.1	0	72	133	84	66
451	65.814	0.147	0.100	2.09	101	-1.15	98	0.1	0	72	133	84	66
452	65.961	0.147	0.102	2.10	100	-2.8	98	0.1	0	72	133	84	66
453	66.108	0.147	0.100	2.09	100	0	98	0.1	0	72	133	84	66
454	66.255	0.147	0.101	2.10	100	-0.44	98	0.1	0	72	133	84	66
455	66.402	0.148	0.102	2.11	100	-0.35	98	0.1	0	72	133	83	66
456	66.550	0.148	0.103	2.12	100	-2.52	98	0.1	0	72	133	83	66
457	66.697	0.146	0.105	2.08	100	0	96	0.1	0	72	133	83	66
458	66.844	0.148	0.101	2.11	100	-2.44	98	0.1	0	72	133	83	66
459	66.990	0.146	0.100	2.07	100	-0.14	98	0.1	0	72	133	83	66
460	67.137	0.147	0.102	2.09	100	-1.84	97	0.1	0	72	133	83	66
461	67.284	0.147	0.100	2.10	100	0	99	0.1	0	72	133	83	66

## BOX A TEST DATA - ASTM E3053 / ASTM E2515

Client: New Buck Corporation  
 Model: 74  
 Run #: 3

Job #: 19-519  
 Tracking #: 0042  
 Technician: AK  
 Date: 10/9/2019

Elapsed Time (min)	Particulate Sampling Data							Fuel Weight (lb)		Temperature Data (°F)			
	Gas Meter (ft <sup>3</sup> )	Sample Rate (cfm)	Dilution Tunnel dP (in H <sub>2</sub> O)	Orifice dH (in H <sub>2</sub> O)	Meter Temp (°F)	Meter Vacuum (in Hg)	Pro. Rate (%)	Scale Reading	Weight Change	Dilution Tunnel	Flue	Filter	Ambient
462	67.430	0.146	0.100	2.08	100	0	98	0.1	0	72	132	83	66
463	67.576	0.146	0.099	2.08	100	0	98	0.1	0	72	132	84	66
464	67.722	0.145	0.102	2.06	100	-2.83	96	0.1	0	72	132	84	66
465	67.869	0.147	0.101	2.10	100	-1.68	98	0.1	0	71	131	84	66
Avg/Tot	67.869	0.146	0.098	2.07	103	-1.11	100			88	248	85	69.8

# BOX B TEST DATA - ASTM E3053 / ASTM E2515

Client: New Buck Corporation

Job #: 19-519

Model: 74

Tracking #: 0042

Run #: 3

Technician: AK

Date: 10/9/2019

Elapsed Time (min)	Particulate Sampling Data							Flue Gas Data		
	Gas Meter (ft <sup>3</sup> )	Sample Rate (cfm)	Orifice dH (in H <sub>2</sub> O)	Meter Temp (°F)	Meter Vacuum (in Hg)	Pro. Rate (%)	Filter (°F)	Flue Draft (in H <sub>2</sub> O)	CO <sub>2</sub> (%)	CO (%)
0	0.000		0.00	90	-1		86	0.000	4.78	0.64
1	0.152	0.152	2.09	90	0	117	86	-0.050	2.10	0.30
2	0.295	0.144	2.05	91	-1.26	105	86	-0.070	2.65	0.51
3	0.435	0.139	2.03	91	-2.24	104	86	-0.100	7.33	1.79
4	0.570	0.135	2.01	91	-1.46	102	86	-0.090	15.09	1.37
5	0.714	0.144	2.05	91	-1.25	111	86	-0.100	16.07	2.21
6	0.866	0.152	2.09	92	-2.42	114	85	-0.090	17.43	2.69
7	1.016	0.150	2.08	92	-2.46	114	85	-0.090	16.56	2.06
8	1.159	0.144	2.05	92	-0.81	108	85	-0.100	16.71	2.48
9	1.284	0.125	1.96	92	-0.33	95	85	-0.090	16.89	2.70
10	1.434	0.150	2.08	92	-2.9	112	85	-0.090	16.75	2.81
11	1.594	0.160	2.13	93	-1.87	120	85	-0.090	16.32	3.60
12	1.750	0.156	2.11	93	-0.38	116	84	-0.090	14.99	1.46
13	1.904	0.154	2.10	93	-2.16	114	84	-0.090	14.26	1.07
14	2.056	0.152	2.09	93	-2.04	112	84	-0.100	14.85	1.02
15	2.206	0.150	2.08	93	-0.94	109	84	-0.080	14.82	1.12
16	2.355	0.150	2.08	93	-0.22	110	84	-0.080	14.77	1.07
17	2.505	0.150	2.08	94	-2.14	110	84	-0.080	15.22	1.21
18	2.651	0.146	2.06	94	-2.11	107	84	-0.090	15.37	1.20
19	2.794	0.144	2.05	94	-2.04	106	84	-0.090	14.91	1.17
20	2.938	0.144	2.05	94	-0.56	105	84	-0.080	15.29	1.23
21	3.088	0.150	2.08	94	-1.03	110	84	-0.070	15.48	1.11
22	3.236	0.148	2.07	94	-0.65	108	84	-0.090	15.69	1.18
23	3.383	0.148	2.07	95	-2.09	108	84	-0.090	15.18	1.22
24	3.527	0.144	2.05	95	-1.35	105	84	-0.100	15.26	1.09
25	3.675	0.148	2.07	95	-1.83	107	84	-0.080	15.25	1.01
26	3.820	0.146	2.06	95	-0.71	107	84	-0.080	15.39	1.06
27	3.964	0.144	2.05	95	-0.8	105	84	-0.080	15.48	1.09
28	4.105	0.142	2.04	95	-2.38	103	84	-0.080	15.43	1.09
29	4.249	0.144	2.05	95	-2.16	105	84	-0.080	15.55	1.11
30	4.395	0.146	2.06	96	-0.47	106	84	-0.080	15.35	1.02
31	4.538	0.144	2.05	96	-0.28	106	84	-0.100	15.18	1.06

## BOX B TEST DATA - ASTM E3053 / ASTM E2515

Client: New Buck Corporation  
 Model: 74  
 Run #: 3

Job #: 19-519  
 Tracking #: 0042  
 Technician: AK  
 Date: 10/9/2019

Elapsed Time (min)	Particulate Sampling Data							Flue Gas Data		
	Gas Meter (ft <sup>3</sup> )	Sample Rate (cfm)	Orifice dH (in H <sub>2</sub> O)	Meter Temp (°F)	Meter Vacuum (in Hg)	Pro. Rate (%)	Filter (°F)	Flue Draft (in H <sub>2</sub> O)	CO <sub>2</sub> (%)	CO (%)
32	4.682	0.144	2.05	96	-0.35	104	84	-0.090	15.16	1.06
33	4.826	0.144	2.05	96	-1.26	105	84	-0.070	15.60	1.05
34	4.967	0.142	2.04	96	-1.33	103	84	-0.080	15.33	1.06
35	5.115	0.148	2.07	96	-0.69	109	84	-0.080	15.45	1.03
36	5.261	0.146	2.06	96	-1.36	106	84	-0.080	15.44	1.15
37	5.408	0.148	2.07	96	-1.49	108	84	-0.090	15.91	1.17
38	5.554	0.146	2.06	96	-2.36	107	84	-0.080	15.72	1.37
39	5.698	0.144	2.05	97	-1.73	106	84	-0.080	15.49	1.42
40	5.843	0.146	2.06	97	-1.75	107	84	-0.090	15.82	1.35
41	5.991	0.148	2.07	97	-2.32	108	83	-0.090	15.39	1.35
42	6.132	0.142	2.04	97	-1.22	104	83	-0.070	15.69	1.30
43	6.274	0.142	2.04	97	-1.52	103	83	-0.070	15.72	1.29
44	6.418	0.144	2.05	97	-2.23	104	83	-0.080	14.95	1.28
45	6.565	0.148	2.07	97	-0.57	108	83	-0.080	15.17	1.17
46	6.709	0.144	2.05	97	-1.2	103	83	-0.070	15.23	1.24
47	6.855	0.146	2.06	97	-1.75	106	83	-0.100	15.20	1.26
48	6.998	0.144	2.05	97	-0.29	103	83	-0.080	15.29	1.11
49	7.142	0.144	2.05	98	-2.36	104	83	-0.070	14.87	1.00
50	7.288	0.146	2.06	98	-2.01	105	83	-0.080	15.20	0.97
51	7.431	0.144	2.05	98	-1.94	103	83	-0.070	15.34	0.96
52	7.573	0.142	2.04	98	-2.03	101	83	-0.080	15.21	0.99
53	7.716	0.144	2.05	98	-2.38	103	83	-0.080	15.16	0.96
54	7.858	0.142	2.04	98	-1.92	102	83	-0.080	15.34	0.86
55	8.003	0.146	2.06	98	-0.35	104	83	-0.070	15.24	0.86
56	8.149	0.146	2.06	98	-2.21	105	83	-0.070	15.39	0.91
57	8.289	0.139	2.03	98	-1.2	100	83	-0.080	15.31	0.94
58	8.428	0.139	2.03	98	-1.64	99	83	-0.070	15.32	0.84
59	8.572	0.144	2.05	98	-0.29	104	83	-0.090	15.64	0.87
60	8.711	0.139	2.03	98	-0.6	100	84	-0.090	15.33	0.83
61	8.849	0.137	2.02	98	-0.43	101	84	-0.080	15.24	0.87
62	8.990	0.142	2.04	98	-1.95	101	85	-0.090	15.11	0.93
63	9.130	0.139	2.03	98	-2.19	100	85	-0.080	15.53	0.85

## BOX B TEST DATA - ASTM E3053 / ASTM E2515

Client: New Buck Corporation  
 Model: 74  
 Run #: 3

Job #: 19-519  
 Tracking #: 0042  
 Technician: AK  
 Date: 10/9/2019

Elapsed Time (min)	Particulate Sampling Data							Flue Gas Data		
	Gas Meter (ft <sup>3</sup> )	Sample Rate (cfm)	Orifice dH (in H <sub>2</sub> O)	Meter Temp (°F)	Meter Vacuum (in Hg)	Pro. Rate (%)	Filter (°F)	Flue Draft (in H <sub>2</sub> O)	CO <sub>2</sub> (%)	CO (%)
64	9.273	0.144	2.05	98	-2.31	104	86	-0.090	15.30	0.83
65	9.419	0.146	2.06	98	-2.25	104	86	-0.090	15.29	0.79
66	9.563	0.144	2.05	98	-1.76	103	86	-0.080	15.44	0.75
67	9.708	0.146	2.06	98	-1.43	106	86	-0.100	15.25	0.74
68	9.854	0.146	2.06	98	-1.48	104	86	-0.080	15.29	0.71
69	10.000	0.146	2.06	99	-2.29	104	86	-0.080	15.43	0.66
70	10.145	0.146	2.06	99	-1.81	106	86	-0.080	15.16	0.76
71	10.287	0.142	2.04	99	-0.9	101	86	-0.070	15.20	0.68
72	10.426	0.139	2.03	99	-1.82	100	86	-0.080	15.21	0.69
73	10.566	0.139	2.03	99	-2	101	86	-0.090	15.05	0.71
74	10.709	0.144	2.05	99	-1.63	102	86	-0.060	15.28	0.65
75	10.853	0.144	2.05	99	-2.31	102	86	-0.080	15.32	0.71
76	10.995	0.142	2.04	99	-0.87	101	86	-0.090	15.16	0.69
77	11.134	0.139	2.03	99	-2.11	101	86	-0.070	15.55	0.59
78	11.276	0.142	2.04	99	-0.32	102	86	-0.070	15.26	0.46
79	11.417	0.142	2.04	99	-0.31	104	86	-0.060	15.18	0.36
80	11.557	0.139	2.03	99	-0.56	100	86	-0.060	15.00	0.31
81	11.700	0.144	2.05	99	-1.68	103	86	-0.070	14.85	0.32
82	11.842	0.142	2.04	99	-0.44	100	86	-0.070	15.15	0.24
83	11.985	0.144	2.05	99	-1.32	102	86	-0.100	14.86	0.22
84	12.127	0.142	2.04	99	-0.54	101	86	-0.070	14.69	0.12
85	12.269	0.142	2.04	99	-1.83	101	86	-0.090	14.04	0.11
86	12.414	0.146	2.06	99	-0.34	103	86	-0.080	14.04	0.09
87	12.558	0.144	2.05	99	-1.42	103	86	-0.080	13.66	0.12
88	12.701	0.144	2.05	99	-2.17	102	86	-0.080	13.82	0.06
89	12.843	0.142	2.04	99	-0.37	100	86	-0.080	13.54	0.00
90	12.982	0.139	2.03	99	-1.82	101	86	-0.070	13.75	0.04
91	13.122	0.139	2.03	99	-0.61	100	86	-0.090	13.41	0.17
92	13.264	0.142	2.04	99	-2.31	102	86	-0.070	14.16	0.09
93	13.403	0.139	2.03	99	-1.23	100	86	-0.070	13.81	0.18
94	13.543	0.139	2.03	99	-0.37	100	86	-0.080	13.27	0.13
95	13.680	0.137	2.02	99	-1.1	98	86	-0.070	12.92	0.19

## BOX B TEST DATA - ASTM E3053 / ASTM E2515

Client: New Buck CorporationJob #: 19-519Model: 74Tracking #: 0042Run #: 3Technician: AKDate: 10/9/2019

Elapsed Time (min)	Particulate Sampling Data							Flue Gas Data		
	Gas Meter (ft <sup>3</sup> )	Sample Rate (cfm)	Orifice dH (in H <sub>2</sub> O)	Meter Temp (°F)	Meter Vacuum (in Hg)	Pro. Rate (%)	Filter (°F)	Flue Draft (in H <sub>2</sub> O)	CO <sub>2</sub> (%)	CO (%)
96	13.822	0.142	2.04	99	-0.45	102	86	-0.080	13.23	0.12
97	13.963	0.142	2.04	99	-1.49	100	86	-0.060	13.36	0.14
98	14.103	0.139	2.03	99	-2.35	99	86	-0.060	13.01	0.09
99	14.246	0.144	2.05	99	-2.12	103	86	-0.060	13.07	0.11
100	14.386	0.139	2.03	99	-1.86	98	86	-0.070	12.82	0.18
101	14.527	0.142	2.04	99	-1.38	101	86	-0.080	12.79	0.20
102	14.667	0.139	2.03	99	-1.91	98	85	-0.060	12.83	0.11
103	14.810	0.144	2.05	99	-1.16	101	85	-0.080	12.48	0.15
104	14.950	0.139	2.03	99	-0.39	98	85	-0.080	12.23	0.10
105	15.089	0.139	2.03	99	-1.57	99	85	-0.050	12.28	0.05
106	15.231	0.142	2.04	99	-1.92	102	86	-0.040	12.19	0.13
107	15.372	0.142	2.04	99	-0.37	101	86	-0.070	12.22	0.10
108	15.514	0.142	2.04	99	-0.44	100	86	-0.070	12.01	0.10
109	15.653	0.139	2.03	99	-0.47	98	86	-0.070	12.35	0.12
110	15.797	0.144	2.05	99	-0.51	102	86	-0.060	11.54	0.19
111	15.939	0.142	2.04	99	-0.3	98	85	-0.040	11.67	0.13
112	16.078	0.139	2.03	99	-0.33	99	85	-0.060	11.41	0.14
113	16.218	0.139	2.03	99	-1.53	98	85	-0.060	11.41	0.08
114	16.357	0.139	2.03	99	-2.29	98	85	-0.080	11.36	0.19
115	16.499	0.142	2.04	99	-2.46	101	85	-0.070	11.31	0.14
116	16.640	0.142	2.04	99	-0.66	100	86	-0.070	11.53	0.11
117	16.780	0.139	2.03	99	-1.69	99	86	-0.060	11.25	0.10
118	16.915	0.135	2.01	99	-0.96	95	86	-0.050	11.39	0.08
119	17.053	0.137	2.02	99	-1.35	97	86	-0.050	11.06	0.22
120	17.194	0.142	2.04	98	-0.26	100	86	-0.050	10.21	0.37
121	17.334	0.139	2.03	99	-1.25	97	85	-0.060	9.97	0.44
122	17.475	0.142	2.04	99	-0.49	100	85	-0.060	9.79	0.43
123	17.619	0.144	2.05	99	-1.61	101	85	-0.050	9.44	0.49
124	17.760	0.142	2.04	99	-1.13	98	85	-0.050	9.49	0.52
125	17.900	0.139	2.03	99	-1	97	85	-0.040	9.73	0.63
126	18.039	0.139	2.03	99	-0.39	99	86	-0.060	9.43	0.62
127	18.183	0.144	2.05	99	-2.25	100	86	-0.080	9.45	0.51

## BOX B TEST DATA - ASTM E3053 / ASTM E2515

Client: New Buck CorporationJob #: 19-519Model: 74Tracking #: 0042Run #: 3Technician: AKDate: 10/9/2019

Elapsed Time (min)	Particulate Sampling Data							Flue Gas Data		
	Gas Meter (ft <sup>3</sup> )	Sample Rate (cfm)	Orifice dH (in H <sub>2</sub> O)	Meter Temp (°F)	Meter Vacuum (in Hg)	Pro. Rate (%)	Filter (°F)	Flue Draft (in H <sub>2</sub> O)	CO <sub>2</sub> (%)	CO (%)
128	18.326	0.144	2.05	99	-2.26	101	86	-0.080	9.42	0.50
129	18.470	0.144	2.05	99	-2.43	101	86	-0.060	9.12	0.69
130	18.614	0.144	2.05	99	-2.42	101	86	-0.060	9.44	0.67
131	18.755	0.142	2.04	99	-1.96	99	85	-0.070	9.17	0.71
132	18.895	0.139	2.03	99	-0.37	98	85	-0.060	9.06	0.62
133	19.036	0.142	2.04	99	-2.35	99	85	-0.080	8.95	0.70
134	19.178	0.142	2.04	99	-1.96	99	85	-0.060	8.75	0.76
135	19.319	0.142	2.04	99	-0.34	99	85	-0.060	8.78	0.75
136	19.459	0.139	2.03	99	-1.45	98	86	-0.060	8.62	0.83
137	19.596	0.137	2.02	99	-0.61	97	86	-0.040	8.29	0.91
138	19.738	0.142	2.04	99	-2.44	99	86	-0.060	8.17	1.04
139	19.879	0.142	2.04	99	-2.4	99	86	-0.050	8.28	1.01
140	20.023	0.144	2.05	99	-2.4	100	86	-0.060	8.02	1.06
141	20.167	0.144	2.05	99	-2.36	101	85	-0.050	8.38	0.95
142	20.310	0.144	2.05	99	-0.28	101	85	-0.040	8.38	0.91
143	20.458	0.148	2.07	99	-0.2	103	85	-0.060	8.66	0.79
144	20.602	0.144	2.05	99	-1.28	100	85	-0.040	8.92	0.78
145	20.743	0.142	2.04	99	-2.44	100	85	-0.050	8.81	0.77
146	20.887	0.144	2.05	99	-2.49	99	86	-0.050	8.68	0.74
147	21.032	0.146	2.06	99	-1.25	101	86	-0.070	8.49	0.76
148	21.174	0.142	2.04	99	-0.81	98	86	-0.050	8.43	0.75
149	21.318	0.144	2.05	99	-0.29	99	86	-0.060	8.03	0.77
150	21.459	0.142	2.04	99	-2.35	98	85	-0.040	8.09	0.80
151	21.603	0.144	2.05	99	-2.1	101	85	-0.050	7.49	0.97
152	21.746	0.144	2.05	100	-0.38	100	85	-0.060	7.37	0.98
153	21.890	0.144	2.05	99	-0.54	100	85	-0.050	7.40	0.97
154	22.029	0.139	2.03	100	-0.69	98	85	-0.070	7.57	1.02
155	22.173	0.144	2.05	100	-2.41	101	85	-0.030	7.53	1.02
156	22.317	0.144	2.05	100	-1.57	101	85	-0.050	7.59	0.92
157	22.460	0.144	2.05	100	-0.35	102	86	-0.060	7.33	1.03
158	22.600	0.139	2.03	100	-2.45	98	86	-0.040	7.43	0.99
159	22.741	0.142	2.04	100	-0.43	98	86	-0.050	7.36	1.05

## BOX B TEST DATA - ASTM E3053 / ASTM E2515

Client: New Buck Corporation  
 Model: 74  
 Run #: 3

Job #: 19-519  
 Tracking #: 0042  
 Technician: AK  
 Date: 10/9/2019

Elapsed Time (min)	Particulate Sampling Data							Flue Gas Data		
	Gas Meter (ft <sup>3</sup> )	Sample Rate (cfm)	Orifice dH (in H <sub>2</sub> O)	Meter Temp (°F)	Meter Vacuum (in Hg)	Pro. Rate (%)	Filter (°F)	Flue Draft (in H <sub>2</sub> O)	CO <sub>2</sub> (%)	CO (%)
160	22.883	0.142	2.04	100	-0.22	98	85	-0.040	7.10	1.00
161	23.029	0.146	2.06	100	-0.41	103	85	-0.040	7.31	1.00
162	23.170	0.142	2.04	100	-2.38	98	85	-0.050	7.48	0.97
163	23.316	0.146	2.06	100	-2.47	101	85	-0.060	7.42	0.94
164	23.457	0.142	2.04	100	-1.84	98	85	-0.070	7.29	0.94
165	23.601	0.144	2.05	100	-0.25	102	85	-0.040	7.36	1.00
166	23.742	0.142	2.04	100	-1.27	99	85	-0.050	7.46	0.96
167	23.884	0.142	2.04	100	-0.83	98	86	-0.050	7.22	0.94
168	24.028	0.144	2.05	100	-2.31	100	86	-0.040	7.09	1.01
169	24.171	0.144	2.05	100	-2.3	100	86	-0.040	7.10	1.00
170	24.315	0.144	2.05	100	-2.5	101	85	-0.040	7.18	0.98
171	24.461	0.146	2.06	100	-2.18	101	85	-0.060	7.03	1.03
172	24.604	0.144	2.05	100	-0.38	99	85	-0.050	7.18	0.97
173	24.746	0.142	2.04	100	-2.47	97	85	-0.050	7.30	0.95
174	24.891	0.146	2.06	100	-0.31	102	85	-0.050	6.69	1.01
175	25.031	0.139	2.03	100	-0.25	97	85	-0.040	7.00	0.97
176	25.174	0.144	2.05	100	-0.97	100	85	-0.040	7.17	0.97
177	25.318	0.144	2.05	100	-1.92	100	85	-0.040	6.84	0.95
178	25.462	0.144	2.05	100	-0.7	99	85	-0.040	6.75	1.02
179	25.605	0.144	2.05	100	-1.02	100	85	-0.040	6.42	0.95
180	25.749	0.144	2.05	100	-2.44	99	85	-0.050	6.43	0.92
181	25.895	0.146	2.06	100	-2.36	101	85	-0.060	6.28	0.84
182	26.034	0.139	2.03	100	-2.06	97	85	-0.030	6.08	0.85
183	26.176	0.142	2.04	100	-0.19	98	85	-0.030	6.12	0.85
184	26.317	0.142	2.04	100	-2.08	97	85	-0.020	6.36	0.91
185	26.461	0.144	2.05	100	-2.35	99	85	-0.030	6.44	0.88
186	26.604	0.144	2.05	100	-1.94	99	85	-0.060	6.00	0.84
187	26.750	0.146	2.06	100	-0.33	102	85	-0.030	6.29	0.87
188	26.896	0.146	2.06	100	-0.85	100	85	-0.040	6.07	0.85
189	27.041	0.146	2.06	100	-0.39	100	85	-0.050	6.24	0.87
190	27.183	0.142	2.04	100	-0.3	99	85	-0.050	6.08	0.79
191	27.324	0.142	2.04	100	-2.46	98	85	-0.040	5.86	0.85



## BOX B TEST DATA - ASTM E3053 / ASTM E2515

Client: New Buck CorporationJob #: 19-519Model: 74Tracking #: 0042Run #: 3Technician: AKDate: 10/9/2019

Elapsed Time (min)	Particulate Sampling Data							Flue Gas Data		
	Gas Meter (ft <sup>3</sup> )	Sample Rate (cfm)	Orifice dH (in H <sub>2</sub> O)	Meter Temp (°F)	Meter Vacuum (in Hg)	Pro. Rate (%)	Filter (°F)	Flue Draft (in H <sub>2</sub> O)	CO <sub>2</sub> (%)	CO (%)
192	27.466	0.142	2.04	100	-0.27	98	85	-0.020	6.17	0.85
193	27.612	0.146	2.06	100	-0.82	101	85	-0.030	6.04	0.78
194	27.757	0.146	2.06	99	-1.49	99	85	-0.040	5.86	0.84
195	27.901	0.144	2.05	99	-0.75	100	85	-0.040	6.05	0.83
196	28.045	0.144	2.05	99	-0.22	100	85	-0.030	5.99	0.82
197	28.186	0.142	2.04	99	-1.99	99	85	-0.040	5.88	0.77
198	28.332	0.146	2.06	99	-0.72	100	85	-0.040	6.19	0.80
199	28.473	0.142	2.04	99	-1.34	97	85	-0.050	6.07	0.81
200	28.617	0.144	2.05	99	-0.28	99	85	-0.040	6.22	0.78
201	28.761	0.144	2.05	99	-2.52	99	85	-0.040	5.61	0.84
202	28.902	0.142	2.04	99	-1.76	100	85	-0.050	6.00	0.79
203	29.044	0.142	2.04	99	-1.88	99	85	-0.050	5.78	0.82
204	29.189	0.146	2.06	99	-0.42	102	85	-0.040	5.89	0.80
205	29.335	0.146	2.06	99	-2.37	100	85	-0.050	5.71	0.84
206	29.475	0.139	2.03	99	-2.39	97	85	-0.040	5.73	0.80
207	29.618	0.144	2.05	99	-0.87	99	85	-0.020	5.81	0.80
208	29.760	0.142	2.04	99	-0.57	98	85	-0.050	5.88	0.87
209	29.905	0.146	2.06	99	-0.45	101	85	-0.060	5.66	0.86
210	30.053	0.148	2.07	99	-2.18	101	85	-0.050	5.59	0.84
211	30.197	0.144	2.05	99	-2.37	100	85	-0.030	5.74	0.82
212	30.338	0.142	2.04	99	-0.24	99	85	-0.030	5.71	0.79
213	30.482	0.144	2.05	99	-2.39	99	85	-0.030	6.11	0.77
214	30.628	0.146	2.06	99	-2.25	100	85	-0.040	5.63	0.80
215	30.771	0.144	2.05	99	-0.52	99	85	-0.020	5.69	0.82
216	30.915	0.144	2.05	99	-0.55	99	85	-0.050	5.88	0.87
217	31.058	0.144	2.05	99	-0.45	99	85	-0.030	6.00	0.84
218	31.204	0.146	2.06	99	-2.22	101	85	-0.040	5.59	0.86
219	31.346	0.142	2.04	99	-1.64	97	85	-0.030	5.61	0.82
220	31.487	0.142	2.04	99	-0.21	97	85	-0.020	5.97	0.79
221	31.629	0.142	2.04	99	-0.27	98	84	-0.050	5.85	0.89
222	31.772	0.144	2.05	99	-0.47	99	85	-0.020	5.68	0.85
223	31.920	0.148	2.07	99	-2.48	102	85	-0.040	5.82	0.84

## BOX B TEST DATA - ASTM E3053 / ASTM E2515

Client: New Buck CorporationJob #: 19-519Model: 74Tracking #: 0042Run #: 3Technician: AKDate: 10/9/2019

Elapsed Time (min)	Particulate Sampling Data							Flue Gas Data		
	Gas Meter (ft <sup>3</sup> )	Sample Rate (cfm)	Orifice dH (in H <sub>2</sub> O)	Meter Temp (°F)	Meter Vacuum (in Hg)	Pro. Rate (%)	Filter (°F)	Flue Draft (in H <sub>2</sub> O)	CO <sub>2</sub> (%)	CO (%)
224	32.062	0.142	2.04	99	-1.13	99	85	-0.040	5.81	0.81
225	32.207	0.146	2.06	99	-1.61	101	85	-0.060	5.52	0.79
226	32.353	0.146	2.06	99	-2.39	100	85	-0.050	5.62	0.74
227	32.494	0.142	2.04	99	-0.5	98	85	-0.030	5.91	0.80
228	32.636	0.142	2.04	99	-0.91	97	85	-0.050	5.64	0.79
229	32.782	0.146	2.06	99	-1.24	101	85	-0.050	5.78	0.78
230	32.925	0.144	2.05	99	-1.3	99	85	-0.050	5.75	0.77
231	33.069	0.144	2.05	99	-2.45	99	85	-0.010	5.74	0.73
232	33.212	0.144	2.05	99	-0.91	99	85	-0.040	6.00	0.69
233	33.354	0.142	2.04	99	-1.79	97	85	-0.040	5.49	0.78
234	33.496	0.142	2.04	99	-2.44	97	85	-0.020	5.95	0.83
235	33.637	0.142	2.04	99	-0.79	97	85	-0.030	5.68	0.78
236	33.783	0.146	2.06	99	-0.23	101	85	-0.020	5.73	0.74
237	33.924	0.142	2.04	99	-1.59	98	85	-0.040	5.84	0.77
238	34.066	0.142	2.04	99	-2.38	98	85	-0.040	5.73	0.79
239	34.210	0.144	2.05	99	-1.5	99	84	-0.020	6.18	0.70
240	34.355	0.146	2.06	99	-0.88	100	84	-0.010	6.02	0.70
241	34.497	0.142	2.04	99	-1.38	97	85	-0.030	5.82	0.76
242	34.642	0.146	2.06	99	-2.11	101	85	-0.050	5.52	0.75
243	34.786	0.144	2.05	99	-2.09	98	85	-0.030	5.43	0.76
244	34.930	0.144	2.05	99	-2.46	98	85	-0.030	5.74	0.70
245	35.073	0.144	2.05	99	-0.33	99	85	-0.040	5.54	0.75
246	35.217	0.144	2.05	99	-0.33	99	85	-0.030	5.40	0.77
247	35.360	0.144	2.05	99	-0.38	100	85	-0.030	5.79	0.69
248	35.502	0.142	2.04	99	-2.33	98	85	-0.030	5.69	0.75
249	35.644	0.142	2.04	99	-1.19	98	84	-0.030	5.78	0.78
250	35.789	0.146	2.06	99	-0.35	100	84	-0.040	5.63	0.78
251	35.933	0.144	2.05	99	-1.22	99	85	-0.040	5.58	0.76
252	36.074	0.142	2.04	99	-0.26	98	85	-0.020	5.83	0.71
253	36.220	0.146	2.06	99	-0.26	101	85	-0.060	5.62	0.80
254	36.364	0.144	2.05	99	-0.88	100	85	-0.050	5.56	0.75
255	36.503	0.139	2.03	99	-1.7	97	85	-0.040	5.34	0.76

## BOX B TEST DATA - ASTM E3053 / ASTM E2515

Client: New Buck CorporationJob #: 19-519Model: 74Tracking #: 0042Run #: 3Technician: AKDate: 10/9/2019

Elapsed Time (min)	Particulate Sampling Data							Flue Gas Data		
	Gas Meter (ft <sup>3</sup> )	Sample Rate (cfm)	Orifice dH (in H <sub>2</sub> O)	Meter Temp (°F)	Meter Vacuum (in Hg)	Pro. Rate (%)	Filter (°F)	Flue Draft (in H <sub>2</sub> O)	CO <sub>2</sub> (%)	CO (%)
256	36.645	0.142	2.04	99	-1.68	97	85	-0.040	5.53	0.75
257	36.792	0.148	2.07	99	-2.29	102	85	-0.040	5.66	0.76
258	36.936	0.144	2.05	99	-0.16	99	85	-0.030	5.66	0.79
259	37.080	0.144	2.05	99	-1.89	100	84	-0.040	5.76	0.78
260	37.223	0.144	2.05	99	-1.13	99	84	-0.040	5.56	0.77
261	37.365	0.142	2.04	99	-1.75	98	85	-0.040	5.46	0.82
262	37.508	0.144	2.05	99	-2.45	98	85	-0.030	5.49	0.74
263	37.656	0.148	2.07	99	-1.32	101	85	-0.030	6.01	0.72
264	37.800	0.144	2.05	99	-2.36	99	85	-0.030	5.73	0.78
265	37.943	0.144	2.05	99	-2.43	99	85	-0.030	5.88	0.69
266	38.083	0.139	2.03	99	-2.32	96	85	-0.040	5.75	0.77
267	38.226	0.144	2.05	99	-2.48	99	85	-0.050	5.76	0.72
268	38.368	0.142	2.04	99	-1.6	98	84	-0.040	5.58	0.72
269	38.514	0.146	2.06	99	-2.01	101	84	-0.020	5.52	0.75
270	38.655	0.142	2.04	99	-0.26	99	85	-0.030	5.47	0.73
271	38.797	0.142	2.04	99	-0.29	97	85	-0.040	5.38	0.74
272	38.938	0.142	2.04	99	-0.25	96	85	-0.060	5.49	0.74
273	39.078	0.139	2.03	99	-0.68	96	85	-0.020	5.46	0.72
274	39.221	0.144	2.05	99	-0.29	99	85	-0.040	5.42	0.76
275	39.365	0.144	2.05	99	-1.93	99	85	-0.040	5.42	0.70
276	39.509	0.144	2.05	99	-1.74	100	85	-0.040	5.23	0.76
277	39.654	0.146	2.06	99	-0.93	101	85	-0.040	5.24	0.73
278	39.796	0.142	2.04	99	-0.13	98	84	-0.030	5.32	0.73
279	39.937	0.142	2.04	99	-0.21	98	84	-0.030	5.41	0.74
280	40.081	0.144	2.05	99	-1.66	100	85	-0.020	5.43	0.72
281	40.227	0.146	2.06	99	-1.01	101	85	-0.040	5.30	0.75
282	40.368	0.142	2.04	99	-1	98	85	-0.030	5.19	0.74
283	40.512	0.144	2.05	99	-1.61	99	85	-0.020	5.47	0.72
284	40.655	0.144	2.05	99	-0.19	99	85	-0.030	5.66	0.67
285	40.799	0.144	2.05	99	-2.42	98	85	-0.030	5.49	0.67
286	40.943	0.144	2.05	99	-1.15	98	84	-0.040	5.25	0.75
287	41.082	0.139	2.03	99	-0.35	96	84	-0.040	5.09	0.75

## BOX B TEST DATA - ASTM E3053 / ASTM E2515

Client: New Buck Corporation  
 Model: 74  
 Run #: 3

Job #: 19-519  
 Tracking #: 0042  
 Technician: AK  
 Date: 10/9/2019

Elapsed Time (min)	Particulate Sampling Data							Flue Gas Data		
	Gas Meter (ft <sup>3</sup> )	Sample Rate (cfm)	Orifice dH (in H <sub>2</sub> O)	Meter Temp (°F)	Meter Vacuum (in Hg)	Pro. Rate (%)	Filter (°F)	Flue Draft (in H <sub>2</sub> O)	CO <sub>2</sub> (%)	CO (%)
288	41.222	0.139	2.03	99	-1.51	96	85	-0.040	5.38	0.72
289	41.365	0.144	2.05	99	-2.4	99	85	-0.040	5.39	0.75
290	41.513	0.148	2.07	99	-0.39	103	85	-0.030	5.32	0.75
291	41.659	0.146	2.06	99	-2.35	100	85	-0.060	5.17	0.77
292	41.798	0.139	2.03	99	-0.22	96	85	-0.040	5.39	0.75
293	41.942	0.144	2.05	99	-0.64	98	85	-0.030	5.34	0.69
294	42.085	0.144	2.05	99	-2.09	98	85	-0.040	5.30	0.73
295	42.227	0.142	2.04	99	-0.36	98	85	-0.030	5.59	0.73
296	42.371	0.144	2.05	99	-0.63	99	84	-0.030	5.41	0.76
297	42.514	0.144	2.05	99	-2.39	100	84	-0.030	5.48	0.73
298	42.654	0.139	2.03	99	-0.87	96	85	-0.030	5.25	0.69
299	42.799	0.146	2.06	99	-0.33	100	85	-0.030	5.58	0.73
300	42.941	0.142	2.04	99	-2.5	97	85	-0.030	5.24	0.72
301	43.087	0.146	2.06	99	-0.47	100	85	-0.030	5.38	0.78
302	43.230	0.144	2.05	99	-1.94	99	85	-0.020	5.46	0.72
303	43.372	0.142	2.04	99	-0.38	97	85	-0.040	5.34	0.69
304	43.513	0.142	2.04	99	-0.92	96	85	-0.060	5.07	0.74
305	43.657	0.144	2.05	99	-1.53	98	84	-0.030	5.34	0.73
306	43.800	0.144	2.05	99	-2.24	98	84	-0.020	5.15	0.67
307	43.944	0.144	2.05	99	-2.51	99	84	-0.030	5.04	0.71
308	44.088	0.144	2.05	99	-0.35	99	85	-0.040	5.01	0.70
309	44.231	0.144	2.05	99	-0.89	99	85	-0.040	5.06	0.74
310	44.375	0.144	2.05	99	-0.42	99	85	-0.020	4.74	0.80
311	44.519	0.144	2.05	99	-2.1	99	85	-0.040	4.74	0.71
312	44.662	0.144	2.05	99	-0.37	99	85	-0.040	4.83	0.72
313	44.806	0.144	2.05	99	-1.29	98	85	-0.020	4.76	0.74
314	44.947	0.142	2.04	99	-2.39	97	84	-0.020	5.21	0.71
315	45.093	0.146	2.06	99	-1.57	101	84	-0.020	4.88	0.73
316	45.235	0.142	2.04	99	-0.58	97	84	-0.030	4.97	0.76
317	45.376	0.142	2.04	99	-1.15	96	85	-0.040	4.93	0.74
318	45.516	0.139	2.03	99	-2.34	96	85	-0.030	4.93	0.70
319	45.659	0.144	2.05	99	-0.26	100	85	-0.050	4.80	0.71

## BOX B TEST DATA - ASTM E3053 / ASTM E2515

Client: New Buck Corporation  
 Model: 74  
 Run #: 3

Job #: 19-519  
 Tracking #: 0042  
 Technician: AK  
 Date: 10/9/2019

Elapsed Time (min)	Particulate Sampling Data							Flue Gas Data		
	Gas Meter (ft <sup>3</sup> )	Sample Rate (cfm)	Orifice dH (in H <sub>2</sub> O)	Meter Temp (°F)	Meter Vacuum (in Hg)	Pro. Rate (%)	Filter (°F)	Flue Draft (in H <sub>2</sub> O)	CO <sub>2</sub> (%)	CO (%)
320	45.801	0.142	2.04	99	-0.25	96	85	-0.030	4.93	0.71
321	45.942	0.142	2.04	99	-1.56	96	85	-0.050	4.79	0.78
322	46.084	0.142	2.04	99	-2.5	97	85	-0.040	4.97	0.63
323	46.227	0.144	2.05	99	-0.29	100	85	-0.050	4.54	0.70
324	46.371	0.144	2.05	99	-1.59	99	84	-0.050	4.73	0.72
325	46.515	0.144	2.05	99	-0.64	98	85	-0.020	4.51	0.69
326	46.660	0.146	2.06	99	-0.27	99	85	-0.040	4.97	0.63
327	46.804	0.144	2.05	99	-0.41	98	85	-0.030	4.95	0.65
328	46.948	0.144	2.05	99	-2.32	98	85	-0.010	4.64	0.72
329	47.095	0.148	2.07	99	-0.71	101	85	-0.020	4.49	0.64
330	47.235	0.139	2.03	99	-1.71	96	85	-0.030	4.66	0.66
331	47.376	0.142	2.04	99	-2	98	85	-0.040	4.64	0.69
332	47.520	0.144	2.05	99	-0.45	100	84	0.000	4.50	0.71
333	47.661	0.142	2.04	99	-0.18	97	84	-0.030	4.52	0.70
334	47.805	0.144	2.05	99	-2.2	100	85	-0.040	4.48	0.68
335	47.947	0.142	2.04	99	-1.67	98	85	-0.030	4.56	0.67
336	48.088	0.142	2.04	99	-2.42	97	85	-0.030	4.60	0.72
337	48.232	0.144	2.05	99	-0.34	98	85	-0.060	4.57	0.68
338	48.373	0.142	2.04	99	-0.48	98	85	-0.030	4.71	0.64
339	48.515	0.142	2.04	99	-1.18	98	85	-0.020	4.55	0.66
340	48.659	0.144	2.05	99	-0.23	99	85	-0.030	4.93	0.63
341	48.798	0.139	2.03	99	-2.39	96	84	-0.040	4.43	0.73
342	48.942	0.144	2.05	99	-0.62	99	84	-0.020	4.84	0.64
343	49.085	0.144	2.05	99	-0.78	99	84	-0.030	4.57	0.71
344	49.227	0.142	2.04	99	-1.5	98	85	-0.040	4.19	0.70
345	49.372	0.146	2.06	99	-1.94	102	85	-0.050	4.77	0.67
346	49.518	0.146	2.06	99	-1.41	100	85	-0.010	4.47	0.69
347	49.658	0.139	2.03	99	-1.95	96	85	-0.030	4.68	0.68
348	49.801	0.144	2.05	99	-1.95	99	85	-0.040	4.44	0.77
349	49.943	0.142	2.04	99	-0.33	97	84	-0.030	4.31	0.69
350	50.086	0.144	2.05	99	-1.42	99	84	-0.040	4.28	0.79
351	50.232	0.146	2.06	99	-1.64	100	84	-0.050	4.47	0.66

# BOX B TEST DATA - ASTM E3053 / ASTM E2515

Client: New Buck Corporation

Job #: 19-519

Model: 74

Tracking #: 0042

Run #: 3

Technician: AK

Date: 10/9/2019

Elapsed Time (min)	Particulate Sampling Data							Flue Gas Data		
	Gas Meter (ft <sup>3</sup> )	Sample Rate (cfm)	Orifice dH (in H <sub>2</sub> O)	Meter Temp (°F)	Meter Vacuum (in Hg)	Pro. Rate (%)	Filter (°F)	Flue Draft (in H <sub>2</sub> O)	CO <sub>2</sub> (%)	CO (%)
352	50.376	0.144	2.05	99	-0.93	98	84	-0.010	4.53	0.69
353	50.519	0.144	2.05	99	-0.25	99	85	-0.020	4.35	0.69
354	50.663	0.144	2.05	99	-0.67	100	85	-0.030	4.21	0.70
355	50.804	0.142	2.04	99	-2.36	96	85	-0.020	4.27	0.73
356	50.944	0.139	2.03	99	-2.5	95	85	-0.020	4.55	0.63
357	51.088	0.144	2.05	99	-2.45	98	84	-0.020	4.63	0.64
358	51.233	0.146	2.06	99	-0.75	101	84	-0.050	4.41	0.73
359	51.377	0.144	2.05	99	-0.28	99	84	-0.030	4.21	0.74
360	51.520	0.144	2.05	99	-2.27	99	84	-0.020	4.44	0.64
361	51.666	0.146	2.06	99	-0.43	100	84	-0.040	4.14	0.68
362	51.810	0.144	2.05	99	-1.87	97	85	-0.030	4.25	0.71
363	51.953	0.144	2.05	99	-2.48	99	85	-0.030	4.47	0.69
364	52.093	0.139	2.03	99	-0.59	96	85	-0.030	4.37	0.66
365	52.236	0.144	2.05	99	-2.27	98	85	-0.040	4.17	0.71
366	52.374	0.137	2.02	99	-0.32	94	84	-0.010	4.36	0.73
367	52.517	0.144	2.05	99	-0.29	98	84	-0.040	4.22	0.73
368	52.663	0.146	2.06	99	-0.35	99	84	-0.030	4.52	0.65
369	52.807	0.144	2.05	99	-1.37	97	84	-0.020	4.38	0.72
370	52.950	0.144	2.05	99	-0.76	99	84	-0.040	4.29	0.65
371	53.092	0.142	2.04	99	-2.42	97	84	-0.020	4.06	0.67
372	53.231	0.139	2.03	99	-1.35	97	85	-0.020	4.34	0.60
373	53.375	0.144	2.05	99	-1.16	99	85	-0.030	4.08	0.66
374	53.521	0.146	2.06	98	-0.38	99	84	-0.030	3.99	0.65
375	53.668	0.148	2.07	98	-2.07	100	84	-0.040	4.14	0.72
376	53.814	0.146	2.06	98	-1.61	101	84	-0.040	3.95	0.67
377	53.956	0.142	2.04	98	-0.39	95	84	-0.020	4.24	0.60
378	54.101	0.146	2.06	98	-0.42	100	84	-0.040	4.04	0.65
379	54.243	0.142	2.04	98	-0.78	96	84	-0.040	4.04	0.64
380	54.386	0.144	2.05	98	-2.41	99	84	-0.020	4.19	0.67
381	54.532	0.146	2.06	98	-0.22	102	84	-0.040	4.14	0.68
382	54.676	0.144	2.05	98	-2.39	99	84	-0.030	4.19	0.62
383	54.815	0.139	2.03	98	-2.41	95	84	-0.020	3.86	0.63

# BOX B TEST DATA - ASTM E3053 / ASTM E2515

Client: New Buck Corporation

Job #: 19-519

Model: 74

Tracking #: 0042

Run #: 3

Technician: AK

Date: 10/9/2019

Elapsed Time (min)	Particulate Sampling Data							Flue Gas Data		
	Gas Meter (ft <sup>3</sup> )	Sample Rate (cfm)	Orifice dH (in H <sub>2</sub> O)	Meter Temp (°F)	Meter Vacuum (in Hg)	Pro. Rate (%)	Filter (°F)	Flue Draft (in H <sub>2</sub> O)	CO <sub>2</sub> (%)	CO (%)
384	54.959	0.144	2.05	98	-0.82	99	84	-0.030	3.87	0.64
385	55.107	0.148	2.07	98	-0.48	102	84	-0.040	3.97	0.64
386	55.250	0.144	2.05	98	-2.42	98	84	-0.040	4.00	0.59
387	55.394	0.144	2.05	98	-0.3	98	84	0.000	3.93	0.62
388	55.535	0.142	2.04	98	-1.16	97	84	-0.040	3.72	0.59
389	55.677	0.142	2.04	98	-0.88	98	84	-0.040	3.80	0.63
390	55.820	0.144	2.05	98	-0.32	98	84	-0.040	3.82	0.55
391	55.966	0.146	2.06	98	-2.5	100	84	-0.030	3.81	0.60
392	56.112	0.146	2.06	98	-0.36	98	84	-0.010	3.89	0.61
393	56.255	0.144	2.05	98	-0.57	98	84	-0.010	3.65	0.60
394	56.395	0.139	2.03	98	-1.78	96	84	-0.030	3.99	0.54
395	56.541	0.146	2.06	98	-1.84	98	84	-0.020	3.95	0.59
396	56.682	0.142	2.04	98	-1.7	97	84	-0.040	3.83	0.60
397	56.826	0.144	2.05	98	-0.36	98	84	-0.030	3.67	0.58
398	56.969	0.144	2.05	98	-2.43	98	84	-0.030	3.83	0.56
399	57.113	0.144	2.05	98	-0.17	99	84	-0.020	3.50	0.56
400	57.255	0.142	2.04	98	-2.33	96	84	-0.020	3.80	0.56
401	57.400	0.146	2.06	98	-2.52	100	84	-0.020	3.55	0.57
402	57.544	0.144	2.05	98	-2.57	97	84	-0.030	3.68	0.59
403	57.687	0.144	2.05	98	-2.31	98	84	-0.020	3.81	0.52
404	57.829	0.142	2.04	98	-2.4	96	84	-0.040	3.78	0.52
405	57.971	0.142	2.04	98	-2.31	96	83	-0.010	3.86	0.57
406	58.112	0.142	2.04	98	-1.44	96	83	-0.010	3.79	0.59
407	58.256	0.144	2.05	98	-2.43	97	83	-0.020	3.90	0.51
408	58.401	0.146	2.06	98	-2.55	98	83	-0.030	3.69	0.59
409	58.547	0.146	2.06	97	-0.55	99	83	-0.040	3.58	0.60
410	58.693	0.146	2.06	97	-2.24	98	82	-0.040	3.46	0.53
411	58.832	0.139	2.03	97	-0.85	96	82	-0.020	3.44	0.60
412	58.976	0.144	2.05	97	-0.46	97	82	-0.040	3.64	0.58
413	59.119	0.144	2.05	97	-0.31	98	82	-0.010	3.61	0.58
414	59.265	0.146	2.06	97	-2.53	100	81	-0.030	3.45	0.56
415	59.409	0.144	2.05	97	-0.28	100	81	-0.030	3.48	0.58

## BOX B TEST DATA - ASTM E3053 / ASTM E2515

Client: New Buck CorporationJob #: 19-519Model: 74Tracking #: 0042Run #: 3Technician: AKDate: 10/9/2019

Elapsed Time (min)	Particulate Sampling Data							Flue Gas Data		
	Gas Meter (ft <sup>3</sup> )	Sample Rate (cfm)	Orifice dH (in H <sub>2</sub> O)	Meter Temp (°F)	Meter Vacuum (in Hg)	Pro. Rate (%)	Filter (°F)	Flue Draft (in H <sub>2</sub> O)	CO <sub>2</sub> (%)	CO (%)
416	59.556	0.148	2.07	97	-1.95	103	81	-0.030	3.55	0.60
417	59.702	0.146	2.06	97	-1.86	99	81	-0.020	3.79	0.60
418	59.848	0.146	2.06	97	-0.39	99	80	-0.020	3.72	0.63
419	59.995	0.148	2.07	97	-1.34	100	80	-0.030	3.53	0.64
420	60.137	0.142	2.04	97	-2.37	96	80	-0.020	3.64	0.61
421	60.285	0.148	2.07	97	-2.26	101	80	-0.030	3.87	0.58
422	60.428	0.144	2.05	97	-0.56	97	80	-0.030	3.63	0.59
423	60.572	0.144	2.05	97	-2.11	97	80	-0.030	3.36	0.58
424	60.716	0.144	2.05	97	-0.77	98	82	-0.020	3.74	0.58
425	60.859	0.144	2.05	97	-1.74	96	83	-0.040	3.53	0.61
426	61.009	0.150	2.08	97	-0.26	103	90	-0.040	3.64	0.62
427	61.153	0.144	2.05	97	-0.51	99	90	-0.020	3.71	0.56
428	61.296	0.144	2.05	97	-2.43	97	89	-0.030	3.73	0.52
429	61.440	0.144	2.05	97	-2.27	98	88	-0.030	3.48	0.57
430	61.583	0.144	2.05	97	-2.59	97	87	-0.030	3.71	0.51
431	61.729	0.146	2.06	96	-0.99	99	86	-0.030	3.92	0.52
432	61.873	0.144	2.05	96	-2.42	97	88	-0.020	3.75	0.58
433	62.016	0.144	2.05	96	-2.09	99	88	-0.040	3.53	0.56
434	62.158	0.142	2.04	96	-1.88	96	88	-0.020	3.49	0.58
435	62.303	0.146	2.06	96	-0.3	99	87	-0.030	3.63	0.59
436	62.445	0.142	2.04	96	-2.33	96	87	-0.030	3.70	0.53
437	62.591	0.146	2.06	96	-0.74	101	86	-0.010	3.58	0.56
438	62.736	0.146	2.06	96	-0.35	99	85	-0.030	3.59	0.62
439	62.878	0.142	2.04	96	-1.29	96	85	-0.030	3.69	0.48
440	63.019	0.142	2.04	96	-2.34	97	85	-0.010	3.48	0.54
441	63.167	0.148	2.07	96	-1.61	99	85	-0.020	3.40	0.52
442	63.317	0.150	2.08	96	-1.99	102	85	-0.030	3.50	0.60
443	63.463	0.146	2.06	96	-2.06	99	85	-0.020	3.46	0.55
444	63.604	0.142	2.04	96	-1.05	96	85	-0.030	3.82	0.49
445	63.748	0.144	2.05	96	-2.55	98	84	-0.030	3.62	0.52
446	63.893	0.146	2.06	96	-0.2	98	84	-0.020	3.69	0.57
447	64.037	0.144	2.05	96	-2.37	97	84	-0.030	3.59	0.58



# BOX B TEST DATA - ASTM E3053 / ASTM E2515

Client: New Buck Corporation  
 Model: 74  
 Run #: 3

Job #: 19-519  
 Tracking #: 0042  
 Technician: AK  
 Date: 10/9/2019

Elapsed Time (min)	Particulate Sampling Data							Flue Gas Data		
	Gas Meter (ft <sup>3</sup> )	Sample Rate (cfm)	Orifice dH (in H <sub>2</sub> O)	Meter Temp (°F)	Meter Vacuum (in Hg)	Pro. Rate (%)	Filter (°F)	Flue Draft (in H <sub>2</sub> O)	CO <sub>2</sub> (%)	CO (%)
448	64.183	0.146	2.06	96	-2.41	98	83	-0.050	3.53	0.54
449	64.326	0.144	2.05	96	-0.74	97	83	-0.020	3.35	0.58
450	64.472	0.146	2.06	96	-2.49	99	83	-0.020	3.54	0.49
451	64.620	0.148	2.07	96	-2	101	82	-0.020	3.09	0.55
452	64.765	0.146	2.06	96	-2.49	98	83	-0.030	3.13	0.52
453	64.909	0.144	2.05	96	-1.41	98	83	-0.020	3.43	0.56
454	65.055	0.146	2.06	96	-0.83	99	83	-0.010	3.60	0.52
455	65.200	0.146	2.06	96	-1.62	98	83	-0.030	3.33	0.52
456	65.352	0.152	2.09	96	-1.63	102	83	-0.020	3.35	0.59
457	65.496	0.144	2.05	96	-1.13	96	82	-0.030	3.27	0.61
458	65.637	0.142	2.04	96	-2.49	96	82	-0.030	3.35	0.59
459	65.779	0.142	2.04	96	-0.26	96	82	-0.030	3.17	0.56
460	65.925	0.146	2.06	96	-2.4	98	81	-0.020	3.34	0.57
461	66.072	0.148	2.07	95	-1.03	101	81	-0.020	3.61	0.50
462	66.216	0.144	2.05	95	-2.42	98	81	-0.030	3.30	0.51
463	66.362	0.146	2.06	95	-2.09	100	81	-0.020	3.40	0.54
464	66.509	0.148	2.07	95	-0.7	100	81	-0.040	3.27	0.47
465	66.655	0.146	2.06	95	-0.71	99	81	-0.030	3.04	0.51
Avg/Tot	66.655	0.143	2.04	98	-1.36	100	85	-0.046	7.63	0.74

# WOODSTOVE SURFACE TEMPERATURE DATA

Client: New Buck Corporation  
 Model: 74  
 Run #: 3

Job #: 19-519  
 Tracking #: 0042  
 Technician: AK  
 Date: 10/9/2019

Elapsed Time (min)	Temperature Data (°F)						Stove Surface Average	Catalyst Exit
	FB Left	FB Right	FB Back	FB Top	FB Bottom			
0	472	482	154	239	169	303.2	N/A	
1	469	480	162	239	168	303.6	N/A	
2	466	474	159	236	169	300.8	N/A	
3	459	467	154	233	169	296.4	N/A	
4	453	460	151	232	171	293.4	N/A	
5	448	454	149	233	171	291.0	N/A	
6	446	448	148	238	171	290.2	N/A	
7	440	445	147	243	170	289.0	N/A	
8	442	441	147	250	169	289.8	N/A	
9	443	440	146	259	170	291.6	N/A	
10	446	439	146	270	170	294.2	N/A	
11	446	438	146	280	170	296.0	N/A	
12	448	437	146	289	170	298.0	N/A	
13	446	435	146	297	170	298.8	N/A	
14	445	433	146	304	169	299.4	N/A	
15	445	431	145	308	170	299.8	N/A	
16	443	429	145	313	169	299.8	N/A	
17	437	428	145	318	169	299.4	N/A	
18	434	426	145	321	168	298.8	N/A	
19	433	424	145	325	168	299.0	N/A	
20	430	423	145	329	168	299.0	N/A	
21	431	423	144	332	168	299.6	N/A	
22	429	422	144	335	168	299.6	N/A	
23	425	420	144	339	164	298.4	N/A	
24	427	420	144	341	165	299.4	N/A	
25	426	419	143	344	165	299.4	N/A	
26	429	418	143	346	164	300.0	N/A	
27	427	419	143	347	164	300.0	N/A	
28	430	418	142	349	164	300.6	N/A	
29	429	418	142	351	164	300.8	N/A	
30	433	418	142	352	164	301.8	N/A	
31	430	417	142	354	162	301.0	N/A	
32	429	418	141	354	162	300.8	N/A	
33	433	417	141	356	161	301.6	N/A	
34	432	417	141	358	161	301.8	N/A	
35	435	418	141	358	161	302.6	N/A	
36	435	418	141	359	160	302.6	N/A	
37	434	418	141	360	160	302.6	N/A	
38	437	419	141	360	160	303.4	N/A	
39	439	420	141	360	160	304.0	N/A	
40	443	420	141	361	160	305.0	N/A	
41	444	421	141	362	160	305.6	N/A	
42	446	421	141	362	160	306.0	N/A	
43	448	423	141	363	159	306.8	N/A	
44	450	423	140	363	159	307.0	N/A	
45	452	424	140	363	158	307.4	N/A	
46	453	425	140	363	159	308.0	N/A	
47	456	426	140	362	158	308.4	N/A	

# WOODSTOVE SURFACE TEMPERATURE DATA

Client: New Buck Corporation  
 Model: 74  
 Run #: 3

Job #: 19-519  
 Tracking #: 0042  
 Technician: AK  
 Date: 10/9/2019

Elapsed Time (min)	Temperature Data (°F)						
	FB Left	FB Right	FB Back	FB Top	FB Bottom	Stove Surface Average	Catalyst Exit
48	458	427	140	363	158	309.2	N/A
49	459	428	140	362	158	309.4	N/A
50	460	429	140	362	157	309.6	N/A
51	460	431	140	362	158	310.2	N/A
52	462	431	140	361	157	310.2	N/A
53	464	433	140	361	157	311.0	N/A
54	464	434	140	360	157	311.0	N/A
55	464	436	140	359	156	311.0	N/A
56	468	437	140	359	157	312.2	N/A
57	469	438	140	359	157	312.6	N/A
58	471	440	140	359	157	313.4	N/A
59	471	441	140	359	156	313.4	N/A
60	473	443	140	358	156	314.0	N/A
61	474	445	140	358	156	314.6	N/A
62	476	447	140	358	156	315.4	N/A
63	476	449	140	357	155	315.4	N/A
64	475	450	140	356	155	315.2	N/A
65	479	452	140	356	155	316.4	N/A
66	481	454	140	355	155	317.0	N/A
67	482	456	141	355	154	317.6	N/A
68	484	457	141	354	155	318.2	N/A
69	485	459	141	353	155	318.6	N/A
70	487	460	141	352	154	318.8	N/A
71	484	462	141	351	154	318.4	N/A
72	487	464	141	350	154	319.2	N/A
73	485	466	141	349	154	319.0	N/A
74	490	467	141	348	154	320.0	N/A
75	490	469	141	347	154	320.2	N/A
76	488	471	141	346	154	320.0	N/A
77	493	472	142	345	154	321.2	N/A
78	492	474	141	345	154	321.2	N/A
79	494	475	141	345	154	321.8	N/A
80	496	476	141	344	154	322.2	N/A
81	497	477	142	344	153	322.6	N/A
82	496	477	142	343	154	322.4	N/A
83	498	477	141	342	153	322.2	N/A
84	500	478	142	341	153	322.8	N/A
85	500	478	142	340	154	322.8	N/A
86	501	479	142	339	153	322.8	N/A
87	500	478	142	337	154	322.2	N/A
88	500	480	142	336	153	322.2	N/A
89	500	479	142	334	153	321.6	N/A
90	500	480	142	332	154	321.6	N/A
91	499	480	143	330	154	321.2	N/A
92	499	481	143	329	154	321.2	N/A
93	499	482	143	327	154	321.0	N/A
94	498	483	143	325	155	320.8	N/A
95	493	483	143	325	152	319.2	N/A

# WOODSTOVE SURFACE TEMPERATURE DATA

Client: New Buck Corporation  
 Model: 74  
 Run #: 3

Job #: 19-519  
 Tracking #: 0042  
 Technician: AK  
 Date: 10/9/2019

Elapsed Time (min)	Temperature Data (°F)						Catalyst Exit
	FB Left	FB Right	FB Back	FB Top	FB Bottom	Stove Surface Average	
96	495	483	142	323	150	318.6	N/A
97	493	484	142	321	149	317.8	N/A
98	490	485	142	319	148	316.8	N/A
99	490	485	141	317	146	315.8	N/A
100	491	485	141	315	146	315.6	N/A
101	493	486	140	312	146	315.4	N/A
102	491	487	140	310	147	315.0	N/A
103	491	487	141	309	147	315.0	N/A
104	491	487	141	306	148	314.6	N/A
105	491	487	141	305	148	314.4	N/A
106	492	487	141	303	148	314.2	N/A
107	490	487	140	301	149	313.4	N/A
108	490	486	141	299	150	313.2	N/A
109	493	486	142	297	150	313.6	N/A
110	487	486	142	295	151	312.2	N/A
111	493	485	142	293	151	312.8	N/A
112	490	485	142	292	151	312.0	N/A
113	490	484	141	289	152	311.2	N/A
114	489	483	141	287	153	310.6	N/A
115	490	483	141	285	153	310.4	N/A
116	489	483	141	283	153	309.8	N/A
117	487	482	141	281	153	308.8	N/A
118	487	482	141	279	154	308.6	N/A
119	487	481	140	278	155	308.2	N/A
120	487	482	140	275	154	307.6	N/A
121	488	480	140	274	154	307.2	N/A
122	487	479	141	271	155	306.6	N/A
123	483	478	140	269	155	305.0	N/A
124	482	477	140	266	155	304.0	N/A
125	482	475	140	264	156	303.4	N/A
126	480	474	140	261	156	302.2	N/A
127	477	472	140	259	156	300.8	N/A
128	479	470	140	256	156	300.2	N/A
129	474	468	140	255	156	298.6	N/A
130	473	467	140	252	156	297.6	N/A
131	472	464	139	250	157	296.4	N/A
132	470	462	140	248	156	295.2	N/A
133	468	460	139	246	157	294.0	N/A
134	468	458	139	244	157	293.2	N/A
135	465	456	139	242	157	291.8	N/A
136	463	454	139	239	157	290.4	N/A
137	461	453	139	238	157	289.6	N/A
138	457	451	138	236	157	287.8	N/A
139	458	448	138	234	158	287.2	N/A
140	455	446	138	231	158	285.6	N/A
141	451	444	138	230	157	284.0	N/A
142	449	442	138	227	157	282.6	N/A
143	447	441	138	226	157	281.8	N/A

# WOODSTOVE SURFACE TEMPERATURE DATA

Client: New Buck Corporation  
 Model: 74  
 Run #: 3

Job #: 19-519  
 Tracking #: 0042  
 Technician: AK  
 Date: 10/9/2019

Elapsed Time (min)	Temperature Data (°F)						Stove Surface Average	Catalyst Exit
	FB Left	FB Right	FB Back	FB Top	FB Bottom			
144	444	440	138	224	156	280.4	N/A	
145	442	439	137	222	157	279.4	N/A	
146	442	439	136	221	157	279.0	N/A	
147	439	438	136	219	157	277.8	N/A	
148	439	438	136	218	157	277.6	N/A	
149	438	437	136	216	157	276.8	N/A	
150	438	435	136	215	157	276.2	N/A	
151	436	434	136	213	157	275.2	N/A	
152	433	432	135	212	157	273.8	N/A	
153	430	430	135	210	157	272.4	N/A	
154	430	428	135	209	157	271.8	N/A	
155	428	427	135	208	157	271.0	N/A	
156	426	424	136	207	157	270.0	N/A	
157	424	422	135	205	157	268.6	N/A	
158	424	420	135	204	157	268.0	N/A	
159	421	418	134	202	157	266.4	N/A	
160	422	416	134	201	157	266.0	N/A	
161	419	414	133	200	157	264.6	N/A	
162	415	412	133	198	157	263.0	N/A	
163	415	410	133	197	156	262.2	N/A	
164	414	408	132	196	156	261.2	N/A	
165	414	406	132	195	156	260.6	N/A	
166	413	404	131	194	156	259.6	N/A	
167	408	403	132	192	156	258.2	N/A	
168	410	401	131	191	155	257.6	N/A	
169	408	399	131	190	155	256.6	N/A	
170	407	397	131	189	155	255.8	N/A	
171	405	396	130	188	155	254.8	N/A	
172	405	395	130	187	155	254.4	N/A	
173	404	393	129	187	155	253.6	N/A	
174	402	392	129	185	154	252.4	N/A	
175	401	391	129	185	154	252.0	N/A	
176	399	389	129	183	154	250.8	N/A	
177	395	388	129	183	154	249.8	N/A	
178	397	387	128	182	155	249.8	N/A	
179	394	386	128	181	153	248.4	N/A	
180	393	384	128	180	154	247.8	N/A	
181	390	382	127	179	153	246.2	N/A	
182	391	381	127	178	153	246.0	N/A	
183	389	379	127	178	153	245.2	N/A	
184	389	377	127	177	153	244.6	N/A	
185	386	376	126	176	153	243.4	N/A	
186	386	374	126	175	152	242.6	N/A	
187	386	373	126	174	152	242.2	N/A	
188	384	371	125	174	152	241.2	N/A	
189	383	370	125	173	152	240.6	N/A	
190	381	368	125	172	152	239.6	N/A	
191	380	366	125	171	152	238.8	N/A	

# WOODSTOVE SURFACE TEMPERATURE DATA

Client: New Buck Corporation  
 Model: 74  
 Run #: 3

Job #: 19-519  
 Tracking #: 0042  
 Technician: AK  
 Date: 10/9/2019

Elapsed Time (min)	Temperature Data (°F)						
	FB Left	FB Right	FB Back	FB Top	FB Bottom	Stove Surface Average	Catalyst Exit
192	380	366	124	171	152	238.6	N/A
193	378	364	124	170	151	237.4	N/A
194	375	362	124	169	151	236.2	N/A
195	372	361	124	169	150	235.2	N/A
196	370	359	124	167	151	234.2	N/A
197	372	358	124	167	150	234.2	N/A
198	369	357	123	166	150	233.0	N/A
199	368	355	123	165	149	232.0	N/A
200	369	353	123	165	150	232.0	N/A
201	368	352	122	164	149	231.0	N/A
202	364	351	123	164	149	230.2	N/A
203	364	349	123	163	148	229.4	N/A
204	361	347	123	162	148	228.2	N/A
205	360	347	122	162	148	227.8	N/A
206	361	345	122	161	148	227.4	N/A
207	357	344	122	161	147	226.2	N/A
208	360	342	122	160	147	226.2	N/A
209	358	341	122	160	147	225.6	N/A
210	355	339	121	159	147	224.2	N/A
211	353	339	121	159	147	223.8	N/A
212	354	337	121	158	147	223.4	N/A
213	352	336	120	158	147	222.6	N/A
214	351	334	120	157	146	221.6	N/A
215	350	333	120	157	146	221.2	N/A
216	350	332	120	156	146	220.8	N/A
217	350	331	119	156	145	220.2	N/A
218	347	329	119	155	145	219.0	N/A
219	349	328	119	155	145	219.2	N/A
220	349	327	119	154	144	218.6	N/A
221	347	326	119	154	144	218.0	N/A
222	346	325	118	154	144	217.4	N/A
223	348	324	118	153	144	217.4	N/A
224	345	323	118	153	143	216.4	N/A
225	345	322	117	152	143	215.8	N/A
226	344	321	118	152	143	215.6	N/A
227	342	320	117	151	143	214.6	N/A
228	340	319	117	151	143	214.0	N/A
229	341	318	117	150	143	213.8	N/A
230	341	317	117	150	143	213.6	N/A
231	340	316	117	150	142	213.0	N/A
232	340	315	117	149	142	212.6	N/A
233	339	315	117	149	142	212.4	N/A
234	338	314	117	149	142	212.0	N/A
235	338	314	117	148	142	211.8	N/A
236	338	313	117	148	142	211.6	N/A
237	338	312	117	148	142	211.4	N/A
238	336	311	116	148	142	210.6	N/A
239	335	310	116	148	141	210.0	N/A

# WOODSTOVE SURFACE TEMPERATURE DATA

Client: New Buck Corporation  
 Model: 74  
 Run #: 3

Job #: 19-519  
 Tracking #: 0042  
 Technician: AK  
 Date: 10/9/2019

Elapsed Time (min)	Temperature Data (°F)						Stove Surface Average	Catalyst Exit
	FB Left	FB Right	FB Back	FB Top	FB Bottom			
240	334	310	116	147	141	209.6	N/A	
241	335	309	116	146	141	209.4	N/A	
242	336	309	116	147	140	209.6	N/A	
243	335	308	116	146	141	209.2	N/A	
244	334	308	115	146	140	208.6	N/A	
245	331	307	116	146	140	208.0	N/A	
246	332	306	116	146	141	208.2	N/A	
247	331	306	115	145	141	207.6	N/A	
248	330	306	115	145	141	207.4	N/A	
249	330	305	115	145	141	207.2	N/A	
250	328	304	115	144	141	206.4	N/A	
251	327	304	115	144	141	206.2	N/A	
252	328	304	115	144	141	206.4	N/A	
253	328	303	115	144	140	206.0	N/A	
254	327	302	115	144	140	205.6	N/A	
255	327	302	115	143	140	205.4	N/A	
256	326	301	115	143	140	205.0	N/A	
257	323	301	115	143	140	204.4	N/A	
258	325	300	115	142	140	204.4	N/A	
259	323	299	115	143	140	204.0	N/A	
260	325	299	115	142	140	204.2	N/A	
261	320	299	115	142	140	203.2	N/A	
262	321	298	115	142	139	203.0	N/A	
263	321	298	115	142	139	203.0	N/A	
264	322	298	115	142	139	203.2	N/A	
265	321	297	114	141	139	202.4	N/A	
266	322	297	115	141	140	203.0	N/A	
267	320	297	114	141	139	202.2	N/A	
268	321	297	114	141	140	202.6	N/A	
269	320	296	114	141	139	202.0	N/A	
270	318	296	114	141	139	201.6	N/A	
271	318	295	114	140	139	201.2	N/A	
272	318	295	114	141	139	201.4	N/A	
273	317	294	114	140	138	200.6	N/A	
274	318	294	114	140	139	201.0	N/A	
275	318	293	114	140	138	200.6	N/A	
276	317	293	114	140	138	200.4	N/A	
277	315	292	114	140	138	199.8	N/A	
278	316	292	114	140	138	200.0	N/A	
279	315	292	114	139	138	199.6	N/A	
280	314	291	114	139	138	199.2	N/A	
281	316	291	113	139	139	199.6	N/A	
282	315	290	114	139	138	199.2	N/A	
283	313	290	113	139	139	198.8	N/A	
284	310	289	113	139	138	197.8	N/A	
285	310	289	113	139	138	197.8	N/A	
286	312	289	113	138	138	198.0	N/A	
287	313	288	114	138	138	198.2	N/A	

# WOODSTOVE SURFACE TEMPERATURE DATA

Client: New Buck Corporation  
 Model: 74  
 Run #: 3

Job #: 19-519  
 Tracking #: 0042  
 Technician: AK  
 Date: 10/9/2019

Elapsed Time (min)	Temperature Data (°F)						Catalyst Exit
	FB Left	FB Right	FB Back	FB Top	FB Bottom	Stove Surface Average	
288	311	288	113	138	138	197.6	N/A
289	311	288	113	138	138	197.6	N/A
290	310	287	113	138	138	197.2	N/A
291	309	287	113	138	138	197.0	N/A
292	309	287	113	138	138	197.0	N/A
293	308	286	113	137	139	196.6	N/A
294	308	286	113	137	138	196.4	N/A
295	307	286	113	137	138	196.2	N/A
296	308	286	113	137	138	196.4	N/A
297	307	285	113	137	138	196.0	N/A
298	306	285	113	137	138	195.8	N/A
299	304	285	113	137	138	195.4	N/A
300	304	285	113	137	137	195.2	N/A
301	304	284	113	136	137	194.8	N/A
302	302	284	113	137	137	194.6	N/A
303	303	284	113	136	137	194.6	N/A
304	305	284	113	136	137	195.0	N/A
305	302	284	113	136	137	194.4	N/A
306	302	283	113	136	137	194.2	N/A
307	304	284	113	136	137	194.8	N/A
308	302	283	113	136	137	194.2	N/A
309	300	283	113	135	137	193.6	N/A
310	300	282	113	135	136	193.2	N/A
311	298	282	114	135	136	193.0	N/A
312	299	281	113	135	136	192.8	N/A
313	298	281	113	135	137	192.8	N/A
314	298	281	113	135	137	192.8	N/A
315	297	280	112	135	137	192.2	N/A
316	298	279	112	134	137	192.0	N/A
317	295	279	112	134	137	191.4	N/A
318	295	278	112	134	137	191.2	N/A
319	294	278	112	134	136	190.8	N/A
320	294	278	112	134	136	190.8	N/A
321	294	277	112	133	136	190.4	N/A
322	293	276	112	134	136	190.2	N/A
323	292	276	112	133	136	189.8	N/A
324	292	275	112	133	136	189.6	N/A
325	292	274	111	133	136	189.2	N/A
326	290	274	112	133	136	189.0	N/A
327	289	273	111	133	136	188.4	N/A
328	289	273	111	133	136	188.4	N/A
329	290	272	111	132	136	188.2	N/A
330	288	271	111	132	136	187.6	N/A
331	288	270	111	132	136	187.4	N/A
332	287	270	110	132	136	187.0	N/A
333	287	269	111	132	136	187.0	N/A
334	287	268	111	132	136	186.8	N/A
335	286	267	111	131	136	186.2	N/A



# WOODSTOVE SURFACE TEMPERATURE DATA

Client: New Buck Corporation  
 Model: 74  
 Run #: 3

Job #: 19-519  
 Tracking #: 0042  
 Technician: AK  
 Date: 10/9/2019

Elapsed Time (min)	Temperature Data (°F)						Stove Surface Average	Catalyst Exit
	FB Left	FB Right	FB Back	FB Top	FB Bottom			
336	285	267	110	131	136	185.8	N/A	
337	285	266	110	131	135	185.4	N/A	
338	284	265	110	131	136	185.2	N/A	
339	282	264	110	131	135	184.4	N/A	
340	281	264	110	130	135	184.0	N/A	
341	281	263	110	130	135	183.8	N/A	
342	281	263	110	130	134	183.6	N/A	
343	281	262	110	130	135	183.6	N/A	
344	281	261	109	129	135	183.0	N/A	
345	278	261	110	129	134	182.4	N/A	
346	278	260	110	129	134	182.2	N/A	
347	278	260	110	129	134	182.2	N/A	
348	277	259	110	129	134	181.8	N/A	
349	276	259	110	128	134	181.4	N/A	
350	277	258	110	128	134	181.4	N/A	
351	277	258	110	128	134	181.4	N/A	
352	276	257	109	128	134	180.8	N/A	
353	274	257	109	128	134	180.4	N/A	
354	272	256	109	128	134	179.8	N/A	
355	273	256	109	127	134	179.8	N/A	
356	274	255	109	127	134	179.8	N/A	
357	272	255	109	127	134	179.4	N/A	
358	272	254	109	127	133	179.0	N/A	
359	271	254	109	126	133	178.6	N/A	
360	270	253	109	126	133	178.2	N/A	
361	270	253	109	126	133	178.2	N/A	
362	270	252	109	126	133	178.0	N/A	
363	271	252	109	126	133	178.2	N/A	
364	270	252	109	125	133	177.8	N/A	
365	270	251	109	125	133	177.6	N/A	
366	268	251	108	125	133	177.0	N/A	
367	269	251	109	125	133	177.4	N/A	
368	268	251	108	125	133	177.0	N/A	
369	268	250	108	125	133	176.8	N/A	
370	268	250	107	125	133	176.6	N/A	
371	266	250	108	124	133	176.2	N/A	
372	265	250	108	124	133	176.0	N/A	
373	265	250	108	124	133	176.0	N/A	
374	265	250	108	124	132	175.8	N/A	
375	264	249	108	123	132	175.2	N/A	
376	265	249	107	123	132	175.2	N/A	
377	262	249	107	123	132	174.6	N/A	
378	262	248	108	123	132	174.6	N/A	
379	262	248	108	123	131	174.4	N/A	
380	262	248	108	123	132	174.6	N/A	
381	262	248	107	122	132	174.2	N/A	
382	261	248	107	122	132	174.0	N/A	
383	260	247	107	122	132	173.6	N/A	

# WOODSTOVE SURFACE TEMPERATURE DATA

Client: New Buck Corporation  
 Model: 74  
 Run #: 3

Job #: 19-519  
 Tracking #: 0042  
 Technician: AK  
 Date: 10/9/2019

Elapsed Time (min)	Temperature Data (°F)						Catalyst Exit
	FB Left	FB Right	FB Back	FB Top	FB Bottom	Stove Surface Average	
384	258	247	107	122	131	173.0	N/A
385	259	246	107	122	131	173.0	N/A
386	258	246	107	122	131	172.8	N/A
387	257	246	106	122	131	172.4	N/A
388	255	245	107	121	130	171.6	N/A
389	257	245	106	121	130	171.8	N/A
390	255	245	106	121	130	171.4	N/A
391	255	245	106	121	131	171.6	N/A
392	255	244	105	121	130	171.0	N/A
393	254	244	105	120	130	170.6	N/A
394	252	243	105	120	130	170.0	N/A
395	251	242	105	120	130	169.6	N/A
396	251	242	106	120	128	169.4	N/A
397	250	241	105	120	128	168.8	N/A
398	250	241	106	119	128	168.8	N/A
399	250	240	106	119	128	168.6	N/A
400	249	240	106	119	128	168.4	N/A
401	250	239	106	119	128	168.4	N/A
402	247	238	105	119	128	167.4	N/A
403	248	238	105	119	128	167.6	N/A
404	247	237	104	118	128	166.8	N/A
405	247	237	105	118	128	167.0	N/A
406	246	236	105	118	128	166.6	N/A
407	245	236	104	118	128	166.2	N/A
408	246	235	104	118	128	166.2	N/A
409	244	235	104	118	127	165.6	N/A
410	244	235	104	118	127	165.6	N/A
411	244	234	104	117	127	165.2	N/A
412	242	234	103	117	127	164.6	N/A
413	243	233	103	117	127	164.6	N/A
414	242	232	103	117	127	164.2	N/A
415	240	232	103	117	127	163.8	N/A
416	240	231	103	116	127	163.4	N/A
417	239	231	103	116	126	163.0	N/A
418	239	231	103	116	127	163.2	N/A
419	239	231	103	116	126	163.0	N/A
420	239	230	103	116	127	163.0	N/A
421	238	230	102	116	126	162.4	N/A
422	239	230	102	115	127	162.6	N/A
423	237	230	102	115	126	162.0	N/A
424	238	229	102	115	126	162.0	N/A
425	238	229	101	115	126	161.8	N/A
426	237	229	101	114	126	161.4	N/A
427	237	229	101	114	126	161.4	N/A
428	237	228	101	114	126	161.2	N/A
429	237	228	101	114	125	161.0	N/A
430	236	227	101	114	125	160.6	N/A
431	236	227	101	114	125	160.6	N/A

# WOODSTOVE SURFACE TEMPERATURE DATA

Client: New Buck Corporation  
 Model: 74  
 Run #: 3

Job #: 19-519  
 Tracking #: 0042  
 Technician: AK  
 Date: 10/9/2019

Elapsed Time (min)	Temperature Data (°F)						Stove Surface Average	Catalyst Exit
	FB Left	FB Right	FB Back	FB Top	FB Bottom			
432	236	227	100	113	125	160.2	N/A	
433	235	226	100	114	125	160.0	N/A	
434	235	226	100	113	125	159.8	N/A	
435	234	225	100	113	124	159.2	N/A	
436	235	225	100	113	124	159.4	N/A	
437	233	225	100	112	124	158.8	N/A	
438	233	224	100	113	123	158.6	N/A	
439	234	224	100	112	124	158.8	N/A	
440	232	223	100	112	124	158.2	N/A	
441	233	223	99	112	123	158.0	N/A	
442	233	222	100	112	123	158.0	N/A	
443	233	222	100	112	123	158.0	N/A	
444	233	222	100	112	123	158.0	N/A	
445	231	221	100	112	123	157.4	N/A	
446	231	221	99	111	123	157.0	N/A	
447	232	221	99	111	123	157.2	N/A	
448	230	221	99	111	123	156.8	N/A	
449	231	220	99	111	122	156.6	N/A	
450	230	220	99	111	122	156.4	N/A	
451	231	220	99	111	122	156.6	N/A	
452	230	219	98	111	122	156.0	N/A	
453	229	219	98	110	122	155.6	N/A	
454	229	219	98	110	122	155.6	N/A	
455	229	218	98	110	121	155.2	N/A	
456	228	218	98	110	121	155.0	N/A	
457	229	217	98	110	121	155.0	N/A	
458	228	217	98	110	121	154.8	N/A	
459	228	217	98	110	121	154.8	N/A	
460	226	217	98	110	121	154.4	N/A	
461	226	216	98	109	121	154.0	N/A	
462	227	216	98	109	121	154.2	N/A	
463	225	216	98	109	120	153.6	N/A	
464	224	216	98	109	120	153.4	N/A	
465	225	215	97	109	120	153.2	N/A	
Average	358	343	122	195	144	232	N/A	

## LAB SAMPLE DATA - ASTM E2515

Client: New Buck Corporation  
 Model: 74  
 Run #: 3

Job #: 19-519  
 Tracking #: 0042  
 Technician: AK  
 Date: 10/9/2019

	Sample ID	Tare, mg	Total, mg	Final, mg	Catch, mg
<b>Train A Filters - First Hour</b>	T355	87.4	173.6	177.2	3.6
	T365	86.2			
<b>Train A Filters - Remainder</b>	T356	87.0	173.7	173.0	-0.7
	T357	86.7			
<b>Train A Probe</b>	7A	116741.4	116741.4	116741.5	0.1
<b>Train A O-Rings</b>	7A	3573.8	3573.8	3575.0	1.2
<b>Train B Filters</b>	T358	86.5	261.2	263.3	2.1
	T364	87.4			
	T366	87.3			
<b>Train B Probe</b>	7B	117289.4	117289.4	117289.7	0.3
<b>Train B O-Rings</b>	7B	3522.9	3522.9	3524.6	1.7
<b>Background Filter</b>			0.0	0.0	

*\*Negative value corrected to zero*

<b>Placed in Dessicator on:</b>	10/10/2019
---------------------------------	------------

<b>Train A Filters - First Hour</b>	177.4	10/15 11:29	177.2	10/16 7:42		
<b>Train A Filters - Remainder</b>	173.1	10/15 11:29	173.0	10/16 7:42		
<b>Train A Probe</b>	116741.5	10/15 11:31	116741.5	10/16 7:45		
<b>Train A O-Rings</b>	3575.3	10/15 11:23	3575.0	10/16 7:38		
<b>Train B Filters</b>	263.4	10/15 11:29	263.3	10/16 7:41		
<b>Train B Probe</b>	117289.6	10/15 11:31	117289.7	10/16 7:46		
<b>Train B O-Rings</b>	3524.9	10/15 11:23	3524.6	10/16 7:39		
<b>Background Filter</b>						

1st hour Sub-Total, mg:	3.6
Remainder Sub-Total, mg:	0.6
<b>Train 1 Aggregate, mg:</b>	<b>4.2</b>
<b>Train 2 Aggregate, mg:</b>	<b>4.1</b>
Ambient Aggregate, mg:	0.0

## ASTM E3053 Wood Heater Run Sheets

Client: New Buck Corporation Job Number: 19-519 Tracking #: 0042  
 Model: 74 Run Number: 3 Test Date: 10/9/2019

### Wood Heater Run Notes

**Pre-Test Notes**

Pre-Test Start Time: 8:08  
 Air Control Setting: N/A

Time	Notes
0:00	Air & fan set to high
0-1:00	Torch lit
2:00	Door closed
33:00	Scale zeroed, test fuel loaded

**Test Notes**

Test Burn Start Time: 10:40  
 Air Control Setting: Medium (0.05" open)

Time	Notes
0:45	Fuel loaded
1:05	Door closed, fan on medium
5:20	Air set halfway to low
10:00	Set air to test setting
10:00	Changed filter A for T365
11:00	Changed B for T366
60:00	Changed A for T356
465:00	Fire out @ 0.1 lb (no measurable change for 30 min), ended sampling

Test Burn End Time: 18:24

### Flue Gas Concentration Measurement

**Calibration Gas Values:** Span Gas CO<sub>2</sub> (%): 15.53 CO (%): 4.084

**Calibration Results:**

	Pre Test		Post Test	
	Zero	Span	Zero	Span
Time	9:53	10:11	18:30	18:28
CO <sub>2</sub>	0.00	15.81	0.29	15.66
CO	0.000	4.077	-0.065	3.919

**Flue Gas Probe Leak Check:** Initial: No Leakage Final: No Leakage

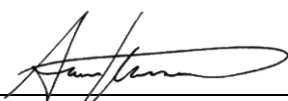
Technician Signature: 

Date: 10/9/2019  
 Page 1 of 3

# ASTM E3053 Wood Heater Run Sheets

Client: New Buck Corporation  
Model: 74

Job Number: 19-519  
Run Number: 3

Tracking #: 0042  
Test Date: 10/9/2019

## Test Photos



**Kindling Fuel Load**



**Start-up Fuel Load**

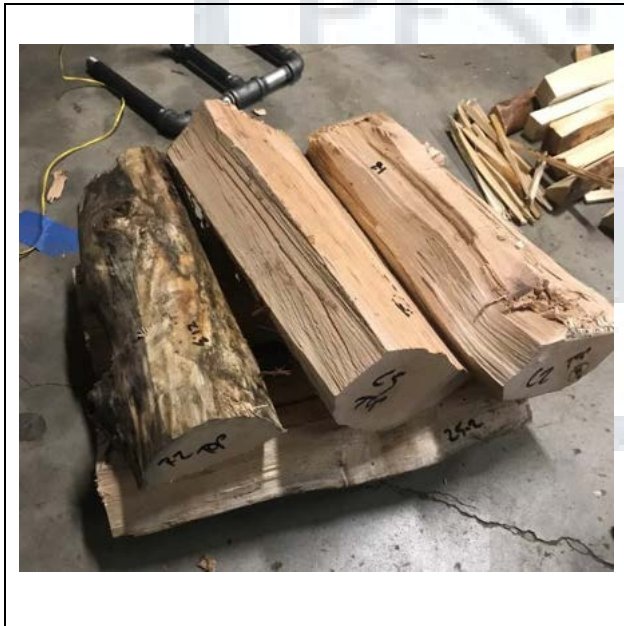

**High Fire Fuel Load**

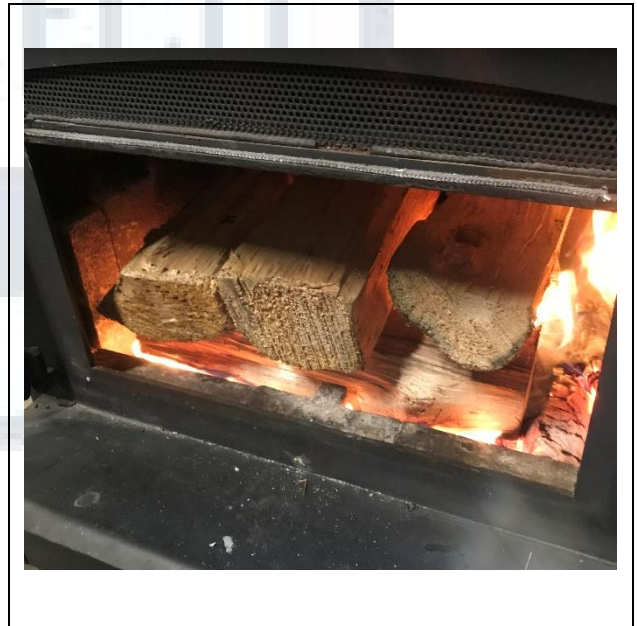

**High Fire Fuel Loaded**

Technician Signature: \_\_\_\_\_

A handwritten signature in black ink, written over a horizontal line.

Date: \_\_\_\_\_

10/9/2019

# ASTM E3053 Wood Heater Run Sheets

Client: New Buck Corporation  
Model: 74

Job Number: 19-519  
Run Number: 3

Tracking #: 0042  
Test Date: 10/9/2019

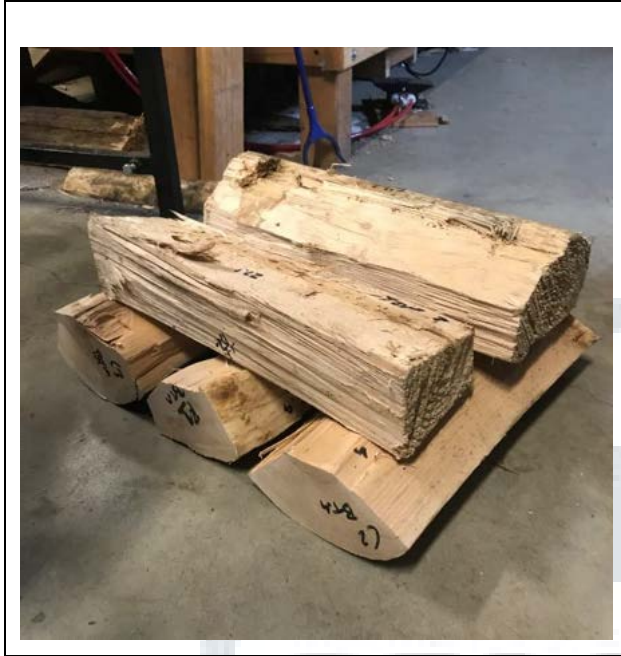

Medium Fire Fuel Load



Medium Fire Fuel Loaded



Technician Signature: 

Date: 10/9/2019  
Page 3 of 3

# ASTM E2515 - TX Filters

Sample	Weight 1	Weight 2	Weight 3	Weight 4	Initial	Project	Run
T323	86.2	86.1	-	-	SB	19-494	#3
T324	87.5	87.4	-	-	SB	19-494	#3
T325	86.1	86.1	-	-	SB	↓	↓
T326	86.0	86.1	-	-	SB	↓	↓
T327	86.1	86.2	-	-	SB	19-494	#4
T328	86.1	86.1	-	-	SB	↓	↓
T329	86.0	86.2	-	-	SB	↓	↓
T330	86.8	86.9	-	-	SB	↓	↓
T331	86.8	86.8	-	-	SB	↓	↓
T332	86.6	86.7	-	-	SB	↓	↓
T333	86.4	86.6	-	-	SB	↓	↓
T334	86.9	87.1	-	-	SB	19-494	#5
T335	87.2	87.3	-	-	SB	↓	↓
T336	89.0	88.9	-	-	SB	↓	↓
T337	86.1	86.2	-	-	SB	↓	↓
T338	86.2	86.3	-	-	SB	↓	↓
T339	86.3	86.3	-	-	SB	↓	↓
T340	86.8	86.8	-	-	SB	↓	↓

Weight 1 Date/Time:
9/9 - 8:00
Weight 2 Date/Time:
9/10 - 14:00
Weight 3 Date/Time:
Weight 4 Date/Time:

Sample	Weight 1	Weight 2	Weight 3	Weight 4	Initial	Project	Run
T341	86.0	86.1	-	-	SB	19-514	1
T342	86.6	86.6	-	-	SB	↓	↓
T343	87.4	87.4	-	-	SB	↓	↓
T344	88.3	88.4	-	-	SB	↓	↓
T345	87.8	87.8	-	-	SB	↓	↓
T346	88.1	88.2	-	-	SB	19-514	2
T347	88.9	88.9	-	-	SB	↓	↓
T348	86.5	86.4	-	-	SB	↓	↓
T349	86.6	86.6	-	-	SB	↓	↓
T350	88.6	88.5	-	-	SB	↓	↓
T351	87.4	87.4	-	-	SB	19-514	1
T352	87.4	87.3	-	-	SB	↓	↓
T353	86.4	86.3	-	-	SB	19-514	2
T354	86.5	86.4	-	-	SB	↓	↓
T355	87.6	87.4	-	-	SB	19-514	3
T356	87.1	87.0	-	-	SB	↓	↓
T357	86.8	86.7	-	-	SB	↓	↓
T358	86.5	86.5	-	-	SB	↓	↓

Weight 1 Date/Time:
9/10 - 14:00
Weight 2 Date/Time:
9/26 - 14:00
Weight 3 Date/Time:
Weight 4 Date/Time:



# ASTM E2515 - TX Filters

Sample	Weight 1	Weight 2	Weight 3	Weight 4	Initial	Project	Run
T359	-	-	-	-	-	-	-
T360	-	-	-	-	-	-	-
T361	-	-	-	-	-	-	-
T362	-	-	-	-	-	-	-
T363	-	-	-	-	-	-	-
T364	87.3	87.4	-	-	SB	19-519	3
T365	86.4	86.2	-	-	SB	↓	↓
T366	87.2	87.3	-	-	SB	↓	↓
T367	87.2	87.2	-	-	SB		
T368	86.6	86.8	-	-	SB		
T369	87.1	87.1	-	-	SB		
T370	86.4	86.6	-	-	SB		
T371	86.5	86.6	-	-	SB		
T372	86.8	86.7	-	-	SB		
T373	87.3	87.2	-	-	SB		
T374	87.3	87.4	-	-	SB		
T375	87.0	87.1	-	-	SB		
T376	87.7	87.8	-	-	SB		

Weight 1 Date/Time:
10/7-9.00
Weight 2 Date/Time:
10/8-8.00
Weight 3 Date/Time:
Weight 4 Date/Time:

Sample	Weight 1	Weight 2	Weight 3	Weight 4	Initial	Project	Run
T377							
T378							
T379							
T380							
T381							
T382							
T383							
T384							
T385							
T386							
T387							
T388							
T389							
T390							
T391							
T392							
T393							
T394							

Weight 1 Date/Time:
Weight 2 Date/Time:
Weight 3 Date/Time:
Weight 4 Date/Time:

# ASTM E2515 - Probes

Sample	Weight 1	Weight 2	Weight 3	Weight 4	Initial	Project	Run
1A	115631.7	115631.8	-	-	SB	19-517	#1
1B	115905.6	115905.8	-	-	SB		
2A	116241.8	116241.8	-	-	SB	19-524	#1
2B	116331.7	116331.6	-	-	SB		
3A	116077.4	116077.4	-	-	SB	19-524	#2
3B	116342.8	116343.0	-	-	SB		
4A	116186.7	116186.8	-	-	SB	19-524	#3
4B	116369.7	116369.7	-	-	SB		
5A	116769.4	116769.6	-	-	SB	19-519	#1
5B	116877.4	116877.5	-	-	SB		

Weight 1 Date/Time:  
9/26 - 14:00

Weight 2 Date/Time:  
9/30 - 7:30

Weight 3 Date/Time:

Weight 4 Date/Time:

Sample	Weight 1	Weight 2	Weight 3	Weight 4	Initial	Project	Run
6A	116545.7	116545.9	-	-	SB	19-519	#2
6B	116119.3	116119.4	-	-	SB		
7A	116741.3	116741.4	-	-	SB	19-519	#3
7B	117289.6	117289.4	-	-	SB		
8A	116823.8	116824.0	-	-	SB		
8B	116826.4	116826.6	-	-	SB		
9A	-						
9B	-						
10A	-						
10B	-						

Weight 1 Date/Time:  
10/3/20

Weight 2 Date/Time:  
10/4 - 8:00

Weight 3 Date/Time:

Weight 4 Date/Time:

Sample	Weight 1	Weight 2	Weight 3	Weight 4	Initial	Project	Run
11A							
11B							
12A							
12B							
13A							
13B							
14A							
14B							
15A							
15B							

Weight 1 Date/Time:

Weight 2 Date/Time:

Weight 3 Date/Time:

Weight 4 Date/Time:

# ASTM E2515 - O-Rings

Sample	Weight 1	Weight 2	Weight 3	Weight 4	Initial	Project	Run
1A	3567.9	3567.8	-	-	SB	19-517	#1
1B	3555.8	3555.8	-	-	SB		
2A	3553.5	3553.6	-	-	SB	19-524	#1
2B	3572.2	3572.1	-	-	SB		
3A	3580.9	3580.8	-	-	SB	19-524	#2
3B	3569.1	3569.1	-	-	SB		
4A	3624.6	3624.7	-	-	SB	19-524	#3
4B	3581.0	3581.1	-	-	SB		
5A	3535.9	3535.9	-	-	SB	19-51A	#1
5B	3531.9	3531.9	-	-	SB		

Weight 1 Date/Time:  
9/26 - 14:00

Weight 2 Date/Time:  
9/27 - 8:00

Weight 3 Date/Time:

Weight 4 Date/Time:

Sample	Weight 1	Weight 2	Weight 3	Weight 4	Initial	Project	Run
6A	3616.4	3616.3	-	-	SB	19-519	#2
6B	3397.7	3397.6	-	-	SB		
7A	3573.7	3573.3	-	-	SB	19-519	#3
7B	3522.7	3522.9	-	-	SB		
8A	3552.5	3552.5	-	-	SB		
8B	3586.1	3586.3	-	-	SB		
9A	-						
9B	-						
10A	-						
10B	-						

Weight 1 Date/Time:  
10/3 - 7:30

Weight 2 Date/Time:  
10/4 - 8:00

Weight 3 Date/Time:

Weight 4 Date/Time:

Sample	Weight 1	Weight 2	Weight 3	Weight 4	Initial	Project	Run
11A							
11B							
12A							
12B							
13A							
13B							
14A							
14B							
15A							
15B							

Weight 1 Date/Time:

Weight 2 Date/Time:

Weight 3 Date/Time:

Weight 4 Date/Time:

CONTACT YOUR LOCAL BUILDING OR FIRE OFFICIALS ABOUT RESTRICTIONS AND INSTALLATION INSPECTION IN YOUR AREA

LISTED FACTORY BUILT OR MASONRY FIREPLACE ACCESSORY/INSERT ROOM HEATERS. SOLID FUEL TYPE. ALSO SUITABLE FOR PERMANENTLY LOCATED MANUFACTURED HOME INSTALLATION PURSUANT TO (HUD 24CFR 3280.709)



Manufactured by  
NEW BUCK CORPORATION.  
P.O. BOX 69  
Spruce Pine, NC 29777

**PREVENT HOUSE FIRES**

Install and use only in accordance with manufacturer's installation and operating instructions and your local building codes.

**CAUTION:** Special methods are required when passing chimney through a wall or ceiling, refer to local building codes. Do not pass chimney connector through a Combustible surface. Do not connect this unit to a chimney flue serving another appliance.

**WARNING: (PERMANENTLY LOCATED MANUFACTURED HOME)** An outside air inlet must be provided for combustion and be unrestricted while unit is in use. Do not install appliance in a sleeping room. The structural integrity of the mobile home floor, walls and ceiling / roof must be maintained.

**Note:** Replace glass only with Part # PG265191GL.

Use only a lined masonry or listed Type HT factory-built chimney.

SERIAL NO.  
TESTED TO: UL 1482  
MODEL: 74 NC  
TYPE OF FUEL: Solid Wood Only

Components required for permanently located manufactured home installation: Pedestal and outside air kit Part #FAP21B,

Optional Components: Side Shield, Air Deflector, Rear Shields. Motor Assembly -MA5126715

Electrical RATING : 115 VAC 1.2 amps 60Hz

DANGER: Risk of electrical shock.

Disconnect power before servicing unit.

Do not route power cord beneath heater.

Do not operate stove with doors open.

"Do Not Use Grate or Elevate Fire – Build Wood Fire Directly on Hearth."

"Do Not Overfire – If Heater or Chimney Connector Glows, You Are Overfiring."

Install insert with a minimum of 16" clearance to combustible sidewall, 10" to side trim and 10" to top trim, 24" from top of insert to mantel or supports. Floor protector must be 3/8" minimum non-combustible material or equivalent, extending 20" in front of fuel door and 8" from each side of fuel door when used in a masonry fireplace. When used as an insert stove, install only in a masonry fireplace, built to UBC Chapter 37 or a listed factory-built Zero-clearance fireplace. See owners manual for models and installation instructions. Do not remove brick or mortar from masonry fireplace to accommodate insert. See instruction manual for masonry insert flue connection options.

Remove and clean behind unit frequently, as creosote buildup may occur rapidly.

"Inspect and clean chimney frequently-under certain conditions of use, creosote buildup may occur rapidly."

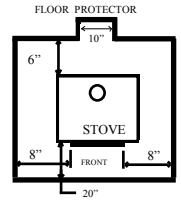
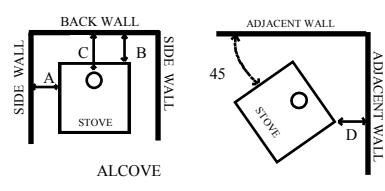
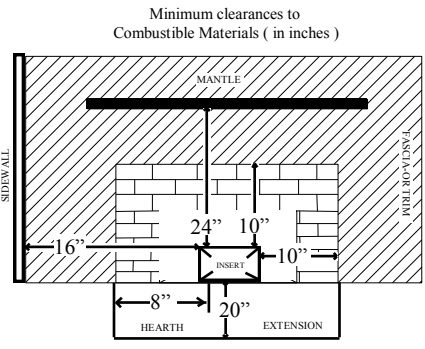

Floor protector must be 3/8" minimum thickness non-combustible material or equivalent, extending beneath heater and to the front/sides/rear as indicated. Also under chimney connector if necessary.

For freestanding installation, non-combustible floor protection with an insulation R-Value of 1.1. must be used under the appliance, 20" beyond the front of the fuel door and 8" to each side of the fuel door.

**MINIMUM CLEARANCE TO COMBUSTIBLE MATERIALS ( in inches )**

Use 24-ga. Black chimney connector.

Residential Single Wall Connector without close clearance shields

Unit to Sidewall	(A) 25"
Unit to Backwall	(B) 8"
Connector to Backwall	(C) 10.5"
Unit Corner to Wall	(D) 8"

Residential and Mobile Home Double Wall or Shielded Single Wall Connector with close clearance shields

Unit to Sidewall	(A) 23"
Unit to Backwall	(B) 4"
Connector to Backwall	(C) 6.5"
Unit Corner to Wall	(D) 4"

Residential and Mobile Home Double Wall or Shielded Single Wall Connector without close clearance shields

Unit to Sidewall	(A) 25"
Unit to Backwall	(B) 4"
Connector to Backwall	(C) 6.5"
Unit Corner to Wall	(D) 8"

Alcove Double or Shielded Single Wall Connector with close clearance Shields

Unit to Sidewall	(A) 23"
Unit to Backwall	(B) 4"
Connector to Backwall	(C) 6.5"
Floor to Ceiling Minimum	84"
Maximum Depth	36"

#PL74

ADHESIVE LABEL  
SILVER LETTERING ON BLACK  
LEFT HEARTH SUPPORT  
EPA LABEL

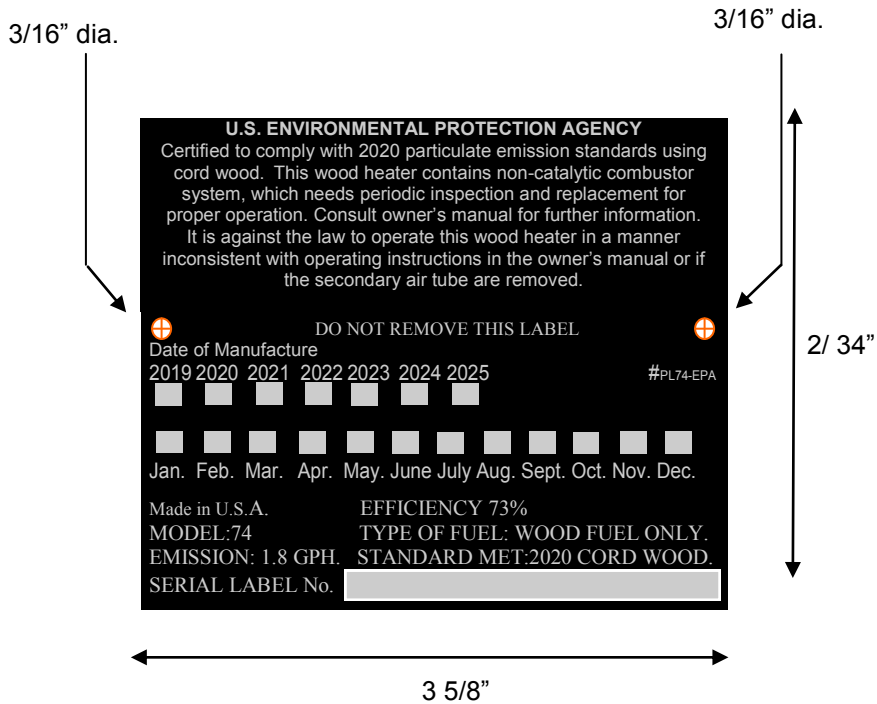

# ADHESIVE BACKING

SILVER LETTERING ON BLACK- (3)SILVER LINES

74 PRIMARY AIR CONTROL ROD DRAFT INDICATOR

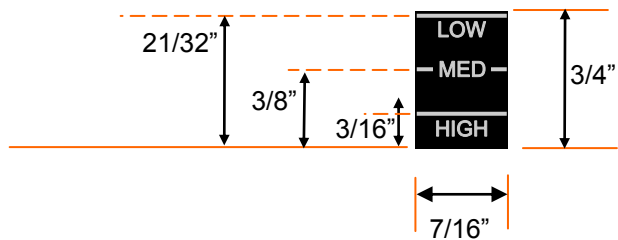

PULL AIR CONTROL ROD ALL WAY OUT. **LOOKING DOWN** PLACE INDICATOR LABEL WITH WORDING "**LOW**" EVEN WITH OUTSIDE OPENING OF COVER DOOR.

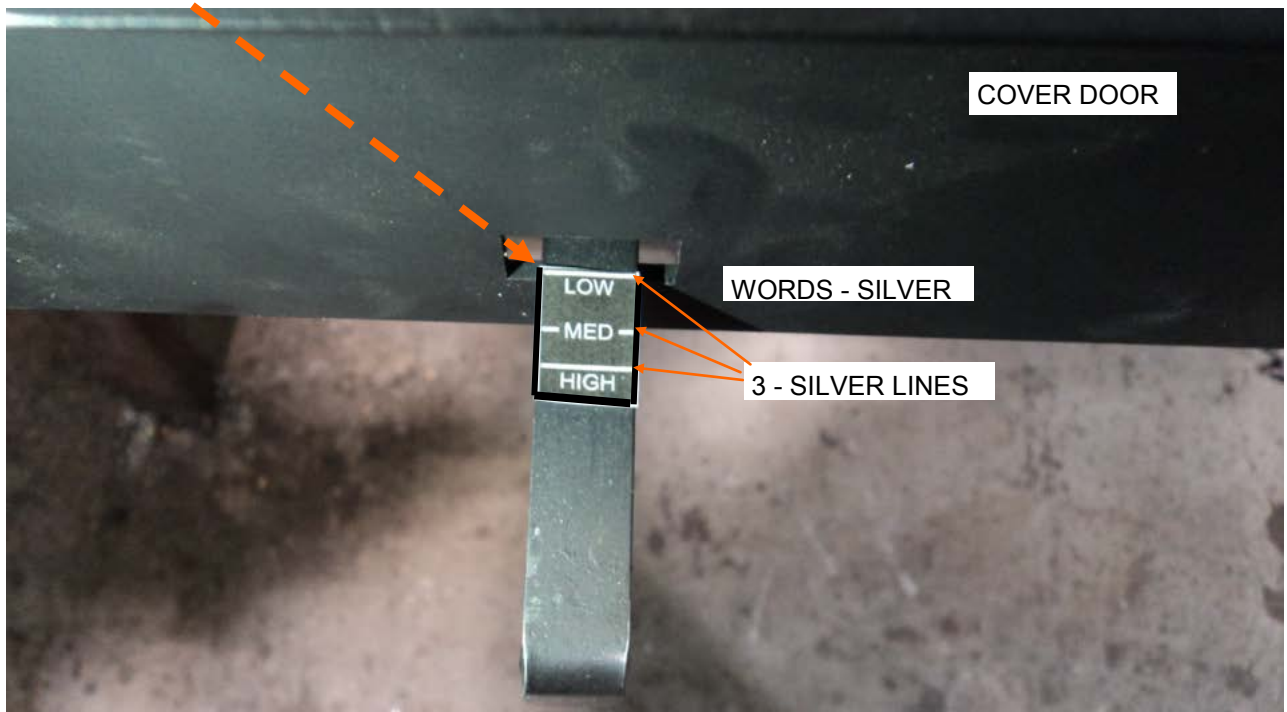

ADHESIVE LABEL

ON BACK RIGHT SIDE OF COVER  
DOOR FACING UNIT

BLACK ON SILVER

**ALL WOOD STOVES**

**CAUTION:** MOVING PARTS MAY CAUSE INJURY. DO  
NOT OPERATE WITH MOTOR GUARD REMOVED  
**DANGER:** RISK OF ELECTRIC SHOCK. DISCONNECT  
POWER BEFORE SERVICING. PL MTRGRD-CAUT

1 1/4"

4 1/2"

# ADHESIVE LABEL

LEFT SIDE OF HEARTH FACING UNIT

RED AND SILVER ON BLACK ON

## ALL WOOD STOVES

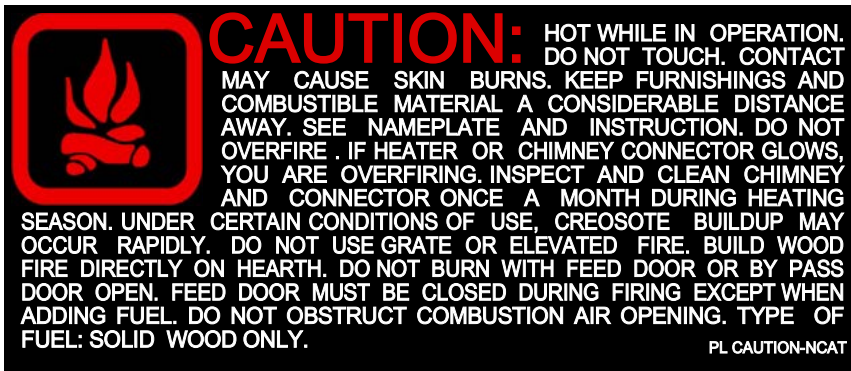

1 15/16"

4 1/2"



**ONLY FOR UNIT THAT WILL GO  
INTO PREFAB FIREPLACES.**

**BOTTOM OF PREFAB FIREPLACE**

**WARNING:** THIS FIREPLACE  
MUST BE RESTORED TO ITS ORIGINAL  
CONDITION FOR SAFE USE, IF THE FIRE  
PLACE INSERT IS REMOVED. PL WRNLBL

1 1/8"



3 5/8"

**PUT IN PACK WITH MANUAL**

**STOVES 18 — 20 — 21 — 74**

**NOTE: ONLY FOR OPTIONAL BLOWER IN BOX .  
MOTOR ROOM ONLY**

**PAPER PEEL AND STICK PLACE ON BLOWER**

**MOTOR ROOM**

**WARNING:**” This electric blower motor is not to be lubricated with any type of lubricant.”  
**NOTE:** This Electrical Motor Is Impedance Protected.  
**Blower Assembly Part Number: MA5126715**

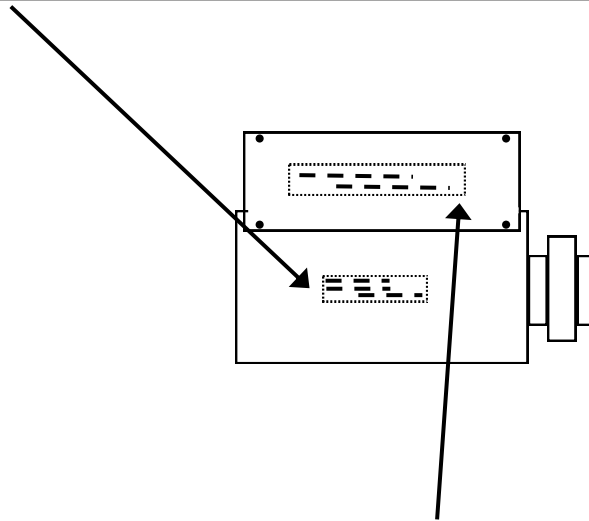

**PAPER PEEL AND STICK PLACE ON BLOWER**

**MOTOR ROOM**

Note: If any of the original wire as supplied with the appliance must be replaced, it must be replaced with type 16GA, 105 degree C. rating wire or its equivalent.

Caution: Label all wires prior to disconnection when servicing controls. Wiring can cause improper and dangerous operation. Verify proper operation after servicing.

**ADHESIVE LABEL FOR ALL POWER CORDS  
NEXT TO PLUG END RED ON WHITE**

**MOTOR ROOM**

**Warning: Electrical Grounding Instructions.** This heater is equipped with a three prong (grounding) plug for your protection against shock hazard and should be plugged directly into a properly grounded three-prong receptacle. **DO NOT** cut or remove the grounding from this plug.

**15/16"**

**4 1/2"**

Manufactured by NEW BUCK CORPORATION

Model 74

U. S. ENVIRONMENTAL PROTECTION AGENCY

## NON-CATALYST

MEETS EPA PARTICULATE MATTER (Smoke) CONTROL REQUIREMENTS FOR NON-CATALYTIC WOOD HEATERS BUILT ON OR AFTER MAY 15,2020 SEE OWNERS MANUAL FOR OPERATION AND MAINTENANCE.

**SMOKE**  
This Model



0 (Grams Per Hour) 7.5

## EFFICIENCY\*



50% 60% 70% 80% 90% 100%

Wood heaters with higher efficiencies cost less to operate.

## HEAT OUTPUT

11,079 TO 28,901 BTU/HR

Use this to choose the right size appliance for your needs.  
ASK DEALER FOR HELP.

This wood heater will achieve low smoke output and high efficiency if properly operated and maintained. See owners manual.

Manufactured by NEW BUCK CORPORATION

Model 74

U. S. ENVIRONMENTAL PROTECTION AGENCY

## NON-CATALYST

MEETS EPA PARTICULATE MATTER (Smoke) CONTROL REQUIREMENTS FOR NON-CATALYTIC WOOD HEATERS BUILT ON OR AFTER MAY 15,2020 SEE OWNERS MANUAL FOR OPERATION AND MAINTENANCE.

**SMOKE**  
This Model



0 (Grams Per Hour) 7.5

## EFFICIENCY\*



50% 60% 70% 80% 90% 100%

Wood heaters with higher efficiencies cost less to operate.

## HEAT OUTPUT

11,079 TO 28,901 BTU/HR

Use this to choose the right size appliance for your needs.  
ASK DEALER FOR HELP.

This wood heater will achieve low smoke output and high efficiency if properly operated and maintained. See owners manual.



**73%**

**OVERALL  
HEATING  
EFFICIENCY**

**MODEL 74**



**73%**

**OVERALL  
HEATING  
EFFICIENCY**

**MODEL 74**



**73%**

**OVERALL  
HEATING  
EFFICIENCY**

**MODEL 74**



**73%**

**OVERALL  
HEATING  
EFFICIENCY**

**MODEL 74**





# TABLE OF CONTENTS

Important Instructions .....	2
Stove Identification .....	3
SECTION I: Introduction.....	4
Type of wood and loading procedures .....	4
Chimney Heights .....	5
SECTION II: Masonry Insert Installation.....	6
Installation Preparation-Fireplace .....	7
Mounting Trim Panels .....	9
SECTION III: Pre-Fab Insert Installation .....	12
SECTION IV: Residential Freestanding Installation .....	13
Floor Protection .....	14
Ceiling Exit Using Single Wall Pipe.....	15
Wall Exit to Metal Tee-Box .....	16
Wall Exit Masonry Flue Using Single Wall Pipe.....	17
Ceiling Exit-Close Clearance.....	18
Clearances To Combustibles Freestanding Without Close Clearance Shields and Using Single Wall Pipe.....	20
Residential / Permanently Located Manufactured Home Double Wall or Shielded Single Wall Connector With Close Clearance Shields .....	21
Residential / Permanently Located Manufactured Home Double Wall or Shielded Single Wall Connector Without Close Clearance Shields .....	22
Installation of Close Clearance Shields (Optional) .....	23
Alcove Installation Double or Shielded Single Wall Connector With Close Clearance Shields.....	24
SECTION V: Freestanding Permanently Located Manufactured Home Installation.....	25
Out Side Air Installation .....	26-27
SECTION VI: Wood Heater Safety .....	31
SECTION VII: Operation .....	32
Guide To The Different Burning Qualities of Wood .....	33
SECTION IV Maintenance:	
Door Gasket Replacement.....	34
Brick Layout .....	35
Secondary Air Tubes Replacement .....	36
Secondary Air Tubes Identification Diagram and Tube location .....	37
Optional Motor Installation.....	38-39
Check Chimney.....	40
Cleaning Heater / Care of Glass.....	41
Troubleshooting .....	42-43
Replacement Parts.....	44
Warranty .....	45

# INSTALLATION, OPERATION AND MAINTENANCE INSTRUCTIONS MODEL 74NC

BEFORE INSTALLING YOUR NEW BUCK STOVE,  
READ THE ENTIRE INSTRUCTION MANUAL

## IMPORTANT INSTRUCTIONS

### WARNING

THIS UNIT GENERATES HIGH HEAT, SO TREAT IT WITH CARE. **HOT WHILE IN OPERATION**. KEEP CHILDREN, CLOTHING AND FURNITURE AWAY. CONTACT MAY CAUSE SKIN BURNS. DO NOT USE CHEMICALS OR FLUIDS TO START THE FIRE. DO NOT BURN GARBAGE OR FLAMMABLE FLUIDS. DO NOT CONNECT TO ANY DISTRIBUTION DUCT OR SYSTEM. READ ALL INSTRUCTIONS BEFORE INSTALLING AND USING THE APPLIANCE. FAILURE TO FOLLOW INSTRUCTIONS MAY RESULT IN PROPERTY DAMAGE, BODILY INJURY OR EVEN DEATH. AVE THESE INSTRUCTIONS FOR FUTURE REFERENCES.

- The New Buck Corp. non-catalytic Model 74NC non-catalytic systems have been tested to UL 1482 Standards and certified by PFS/TECO. Standard for Room Heaters, Solid Fuel Type.
- Install and operate your unit according to instructions provided in this manual. Local building codes may apply; therefore, contact your local building inspector or fire marshal for necessary installation requirements and permits which may go beyond these instructions. Contact your insurance company for coverage and installation inspection.
- **If appliance is installed in permanently located manufactured homes:  
DO NOT INSTALL IN SLEEPING ROOMS.**
- **NOTE: When burning any unit or appliance that combusts fuel for heat, such as coal, oil, wood or natural and (L.P.) liquid petroleum gas. Correctly place monitors in those areas that are expected to produce CO. Consult with your local fire safety officials to learn more**
- Examine the masonry fireplace and chimney prior to installation of fireplace accessory to determine that construction meets the minimum fireplace construction requirements illustrated in the instructions. Make sure that it is free from cracks, loose mortar, creosote deposits and other blockage, or other signs of deterioration.

### CAUTION

DO NOT USE MORE THAN ONE STOVE PER CHIMNEY. DO NOT USE A FLUE INTENDED FOR A GAS APPLIANCE. DO NOT CONNECT TO ANY DISTRIBUTION DUCT OR SYSTEM.



## EPA COMPLIANCE STATUS

This manual describes installation and operation of the New **Buck Corporation Model 74** wood heater. This heater meets the U.S. Environmental Protection Agency's Emission limits for wood heaters and is in compliance with 2020 particulate emission standard. Under specific test conditions, this heater has been shown to deliver heat at rates ranging from approximately 11,079-28,901 BTU/hr four the Model 74. A weighted average was used to calculate the overall efficiency across all of the burn rate categories using the higher heating value (HHV73%).

## MODEL 74 WOOD STOVE IDENTIFICATION

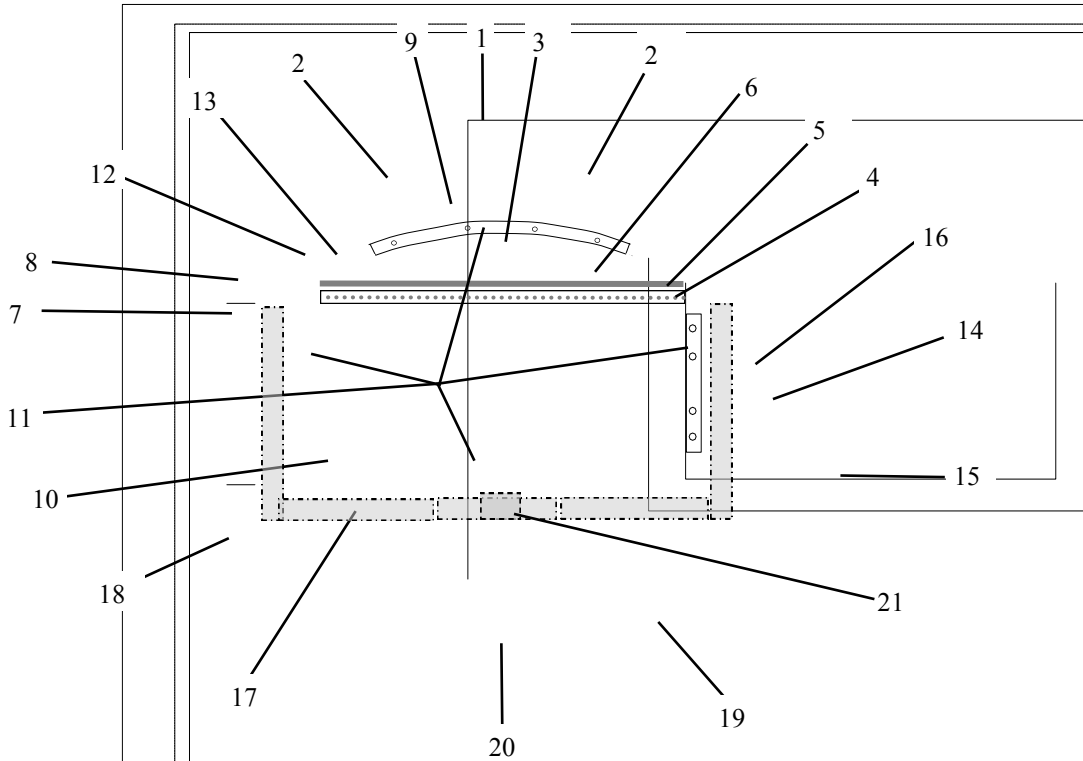

- |  |                                    |
|--|------------------------------------|
| 1. 6" Flue Exit                          | 14. Door Handle                    |
| 2. Warm Air Outlets                      | 15. Spring Handle                  |
| 3. Air Wash and Screen                   | 16. -Door Latch                    |
| 4. Secondary Air Tubes                   | -Door Latch Screw                  |
| 5. Top Baffle Board                      | -Door Handle Bushing               |
| 6. Fire Blanket                          | -Door Handle Spacer                |
| 7. Hinge Block                           | -Door Latch Flat Washer            |
| 8. Hinge Pins                            | -Door Latch Screws (Phillips Head) |
| 9. Door                                  | -Door Latch Screws (Allan Head)    |
| 10. Door Glass                           | 17. Firebrick                      |
| 11. Glass Clips Small; Side, Top, Bottom | 18. Hearth Extension               |
| 12. Door Gasket                          | 19. Cover Door                     |
| 13. Door Glass Gasket                    | 20. Primary Air Control            |
|  | 21. Shotgun Air Box                |

## CAUTION

YOUR CHIMNEY MUST BE CORRECTLY SIZED. A CHIMNEY THAT IS TOO SMALL OR LARGE IN DIAMETER, OR TOO SHORT, CAN CAUSE YOUR STOVE TO SPILL SMOKE WHEN DOOR IS OPENED.

## SECTION I

### INTRODUCTION

Your new MODEL 74 is a non-catalytic unit designed to meet the most stringent emissions standards without use of a catalytic combustor. This effect is achieved through use of secondary air which is mixed with primary air in unit's firebox.

For peak performance, we suggest use of natural seasoned hard wood, loading wood from front to rear.

NOTE: Soft woods such as pine, create more creosote, clogging of chimney and produce a less efficient burn performance.

You should not burn trash or garbage, artificial or paper logs, gift wrapping, treated or painted wood or any type of coal or flammable fluids.

**DO NOT USE CHEMICALS OR FLUIDS TO START THE FIRE.  
DO NOT BURN GARBAGE OR FLAMMABLE FLUIDS.”**

The primary air, which is controlled by user, burns wood. Secondary air is admitted into firebox through secondary air tubes at top of firebox. This secondary air burns impurities in smoke released from initial wood burning. The temperature necessary for this combustion is maintained through firebrick refractory. If any more technical information is necessary, contact your local dealer.

Under specific test conditions this heater has been shown to deliver heat at rates ranging from approximately 13,300 to 52,400 BTU/HR.

This unit may also be used with optional room air blower. To order optional motor assembly you must specify stove model number and give following part number:

\*Model 74: Motor Assembly—MA 5126715

For operation and use of this electrical assembly, see instructions provided with motor assembly kit.

# CHIMNEY HEIGHTS

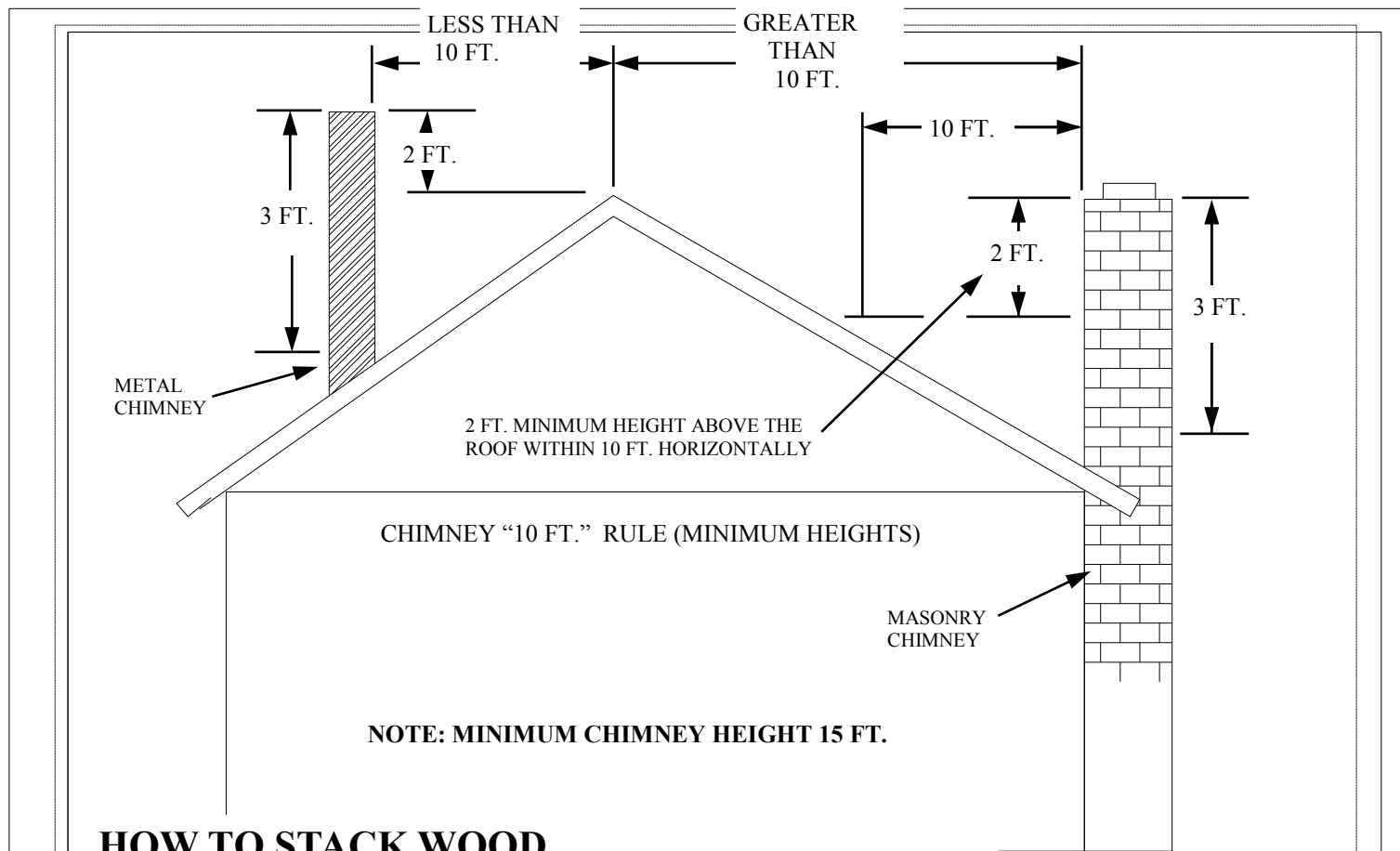

## HOW TO STACK WOOD

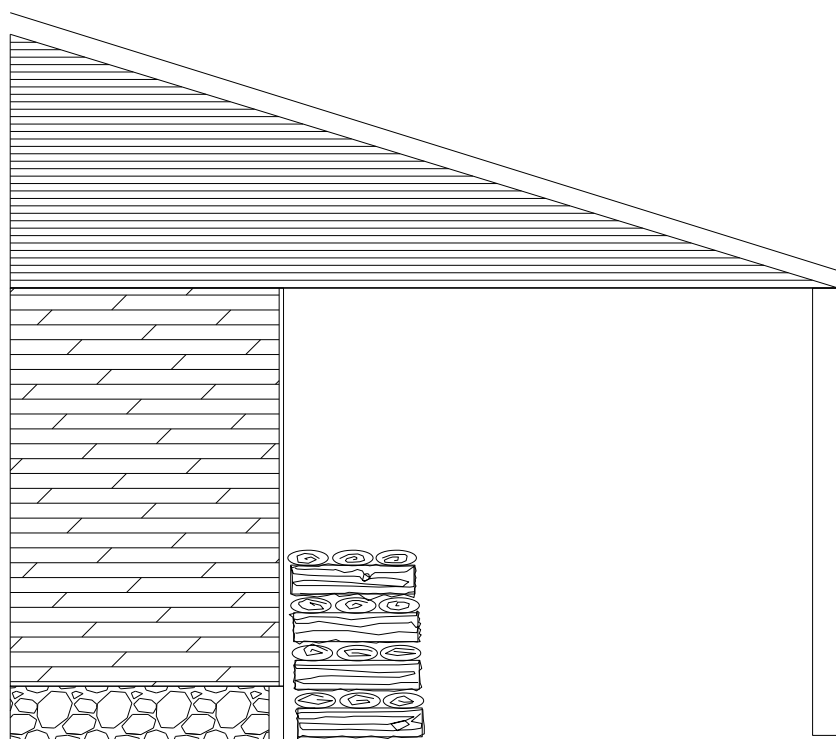

## SECTION II

### MASONRY INSERT INSTALLATION

The Model 74 may be installed using an all masonry fireplace built in accordance with Uniform Building Code and National Fire Protection Association (NFPA). The first step in this type of installation is to determine acceptability of fireplace and chimney for use with a woodstove. Both construction and condition of fireplace are important considerations when installing a woodstove. The chimney should extend at least 3' above roof and at least 2' above any point of roof within 10' (See Page 5).

### CAUTION

REMEMBER TO HAVE YOUR CHIMNEY INSPECTED FOR LEAKS AND BLOCKAGE BEFORE YOU INSTALL YOUR STOVE. DO NOT CONNECT THIS UNIT TO A CHIMNEY FLUE SERVING ANOTHER APPLIANCE.

### MINIMUM CLEARANCE MASONRY INSERT

#### MODEL 74

A. Side Wall Combustible	16"
B. Front Floor Protector	20"
C. Side Floor Protector	8"
D. Side Wood Trim	10"
E. Top Wood Trim	10"
F. Mantel or Brackets	24"

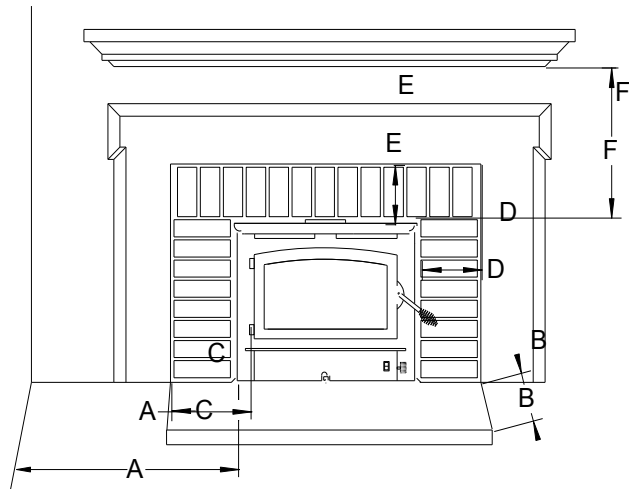

1. The hearth must be of masonry construction and must extend a minimum of 20" in front of firebox opening and a minimum of 8" to either side of firebox opening.
2. If there is not minimum hearth protection from front of firebox opening and front of masonry hearth, a floor protector must be used in front of hearth to protect combustible materials. The floor protector must be 3/8" minimum thickness noncombustible material or equivalent.(See Page 14).

## POSSIBLE TOOLS NEEDED FOR INSTALLATION

If you decide to install your own stove, there are several hand tools you may need to do the job. If you do not already have them, they are readily available at most hardware stores.

Caulking gun

Large adjustable wrench (may not be needed)

Drop cloths or newspapers

Vacuum cleaner or whisk broom

Flashlight

1 tube of RTV silicone, Code 103 or 106, or high temperature rubber cement rated between 450° F- 600° F

7/32" drill bit and drill

Socket/Ratchet Set

## INSTALLATION PREPARATION

### Fireplace:

1. Relocate furniture and other materials away from front of fireplace to allow free access to fireplace.
2. Cover hearth and adjacent floor areas with a drop cloths to protect from soiling or marring surface.
3. Remove existing fireplace damper plate.
4. Thoroughly clean fireplace of ashes and soot.
5. Check chimney and smoke chamber for excessive buildup of creosote or soot. Also, check for obstructions, such as bird's nests. If chimney is excessively dirty, clean it or have someone clean it professionally before installing or using room heater.
6. If fireplace has an ash dump or outside air provision, these must be sealed off with metal or tightly packed non-combustible insulation to prevent cold air from entering fireplace chamber.

---

## MASONRY INSERT INSTALLATION INSTALLATION OPTIONS

This unit (appliance) may be installed into an all masonry fireplace, built in accordance with Uniform Building Code and National Fire Protection Association (*NFPA 211*).

**NOTE:** Check with local building officials for any permits required for installation of this unit and notify your insurance company before proceeding with installation

In cases such as improperly drawing fireplace, oversize flue liners are to meet codes in certain areas as it is recommended that one of the following procedures be followed.

- A. A **Chimney Connector** can be installed from appliance flue exit through damper and with air-tight face seal. (See option (A) Page 8).
- B. A listed **Direct Connect** can be installed from appliance flue exit through damper into the first section of flue liner with air-tight seal. (See option (B) Page 8).
- C. A **Positive Connect** can be installed from appliance flue exit, continuing up through entire chimney and exiting at top of the chimney. (See option (C) Page 8).

**OPTION (A)**

SEAL TRIM PANELS AND UNDER FRONT OF STOVE UNIT WITH INSULATION OR HIGH TEMPERATURE CAULK

STARTER PIPE

AIRTIGHT INSULATED CLEAN-OUT

REMOVE DAMPER OR WIRE IT OPEN

**NOTE:** New Buck Corporation grants no warranty, implied or stated, for the installation or maintenance of your appliance, and assumes no responsibility of any consequential damage (s).

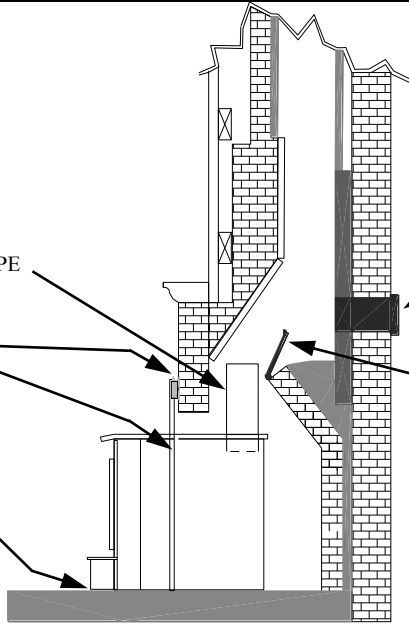

**OPTION (C)**

**NOTE:** Follow installation

CAP (PREVENTS WATER FROM ENTERING)

FLUE LINER

INSTALL A NON-COMBUSTIBLE COVER PLATE TO PREVENT WATER FROM ENTERING THE CHIMNEY

THE LINER MUST BE STAINLESS STEEL CONNECTOR OR FLEXIBLE VENT. FOLLOW THE LINER MANUFACTURE'S INSTRUCTIONS FOR INSTALLATION AND SUPPORT.

AIRTIGHT INSULATED CLEAN-OUT

REMOVE DAMPER OR WIRE IT OPEN

TRIM PANELS

(Kit sold separately)

SEAL TRIM PANELS WITH INSULATION OR HIGH TEMPERATURE CAULK

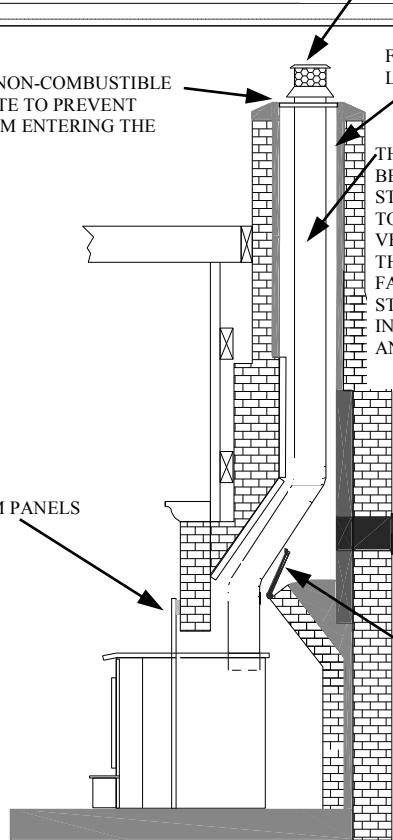

# INSTALLATION PROCEDURE

(Use a chimney connector or a Listed Direct or Positive Connect) (See Page 8)

## POSITIONING HEATER

When positioning heater, following conditions must be met! (See Figure 8).

1. The front of damper opening must be positioned **BEHIND** rear edge of lintel to ensure proper operation. (See Figure 8).
2. Center heater in fireplace opening.

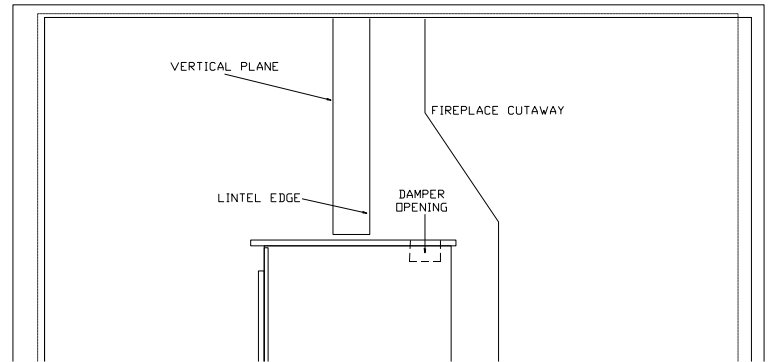
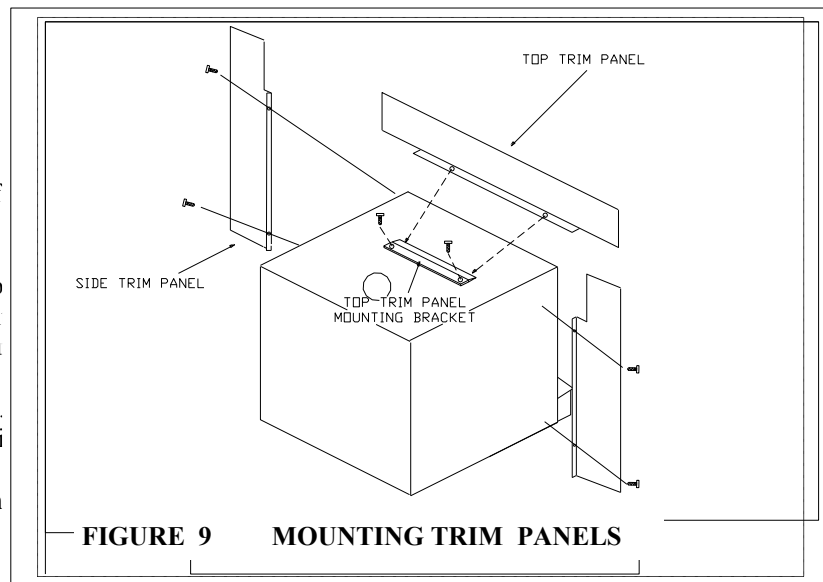

**FIGURE 8 POSITIONING**

## MOUNTING TRIM PANELS

After unit is positioned, mark the mounting position of the trim panels as follows:

1. Place side trim panels in place, flat against face of fireplace. Mark down front edge of trim panel with pencil to make a vertical reference line. (See Figure 9).
2. Place top (long) trim panel in place on top of unit. The panel should be flat against outside face of fireplace and standing vertically. Mark along lower edge of trim panel with a pencil to make a reference line for mounting.
3. Slide unit out of fireplace far enough to work behind trim panel reference lines.
4. Mount side trim panels. (See Figure 9).
  - a. Position trim panel on reference line.
  - b. Drill mounting holes in center of trim panel mounting brackets to allow for adjustment in and out if necessary.
  - c. Mount trim panel using self-tapping screws provided.
5. Place top panel back on reference mark. Take top trim panel mounting bracket supplied with unit. Position bracket so it overlaps rear lip of top trim panel. Drill mounting holes in top of stove using holes in bracket as guide. Tighten down screws.
6. Now, follow installation procedures in listed direct connect or positive connect kit you are using and install heater connect kit in fireplace. If not using one of installation methods shown on (Page 8). Continue.
7. Slide unit back into fireplace. Check to be sure that trim panels are properly positioned and lie flat against front of fireplace. If one or more of the panels is out of position, slide unit out and reset by loosening mounting screws and repositioning in slot.
8. Reinstall top trim panel by sliding rear lip of top trim panel underneath front lip of mounting bracket already secured to top of unit.

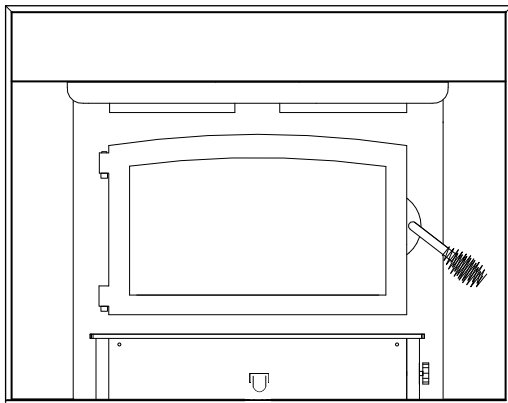

**FIGURE 9 MOUNTING TRIM PANELS**

**NOTE:** Mount top trim panel so that it sits in front of top of side trim panels.

9. Obtain brass trim kit provided with insert kit and slip over top and sides of trim panels. Top ends of brass may need to be trimmed to fit (See Figure 10).
10. Using insulation provided, peel and stick to back of panels overlapping fireplace dimensions by 1" on each side and top. (See Figure 11).
11. Next using high heat silicone or furnace cement, run heavy bead of caulking around where panels meet stove. (See Figure 11).
12. Slide unit back into fireplace. Check to be sure that trim panels (and brass) are properly positioned and lie flat against front of fireplace. If panels are out of position, slide unit out and reset by loosening mounting screws and repositioning in the slot. With bar lift stove up in front. Place insulation across front and surface of hearth or bottom of fireplace to make complete seal.
13. To check seal of panels, use candle flame and go around entire area sealed by silicone and insulation. If flame leans toward inside of fireplace, add additional insulation. This ensures an airtight seal.

Outer Trim



## FINAL CHECK

FIGURE 10

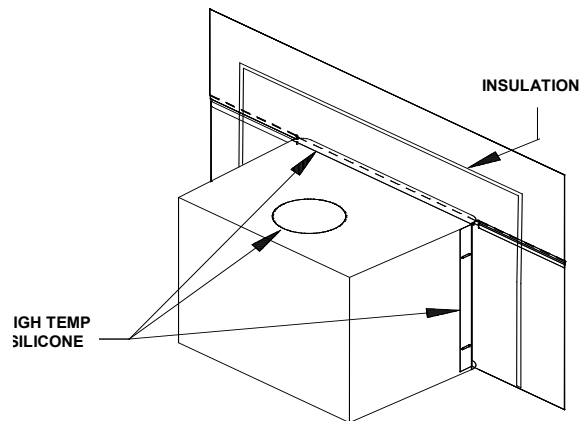

FIGURE 11

1. Recheck specified clearances.
2. Remove all foreign material from firebox area.
3. Open primary air control  
**Primary Air Control:** The primary air intake draft control is located at center of hearth. It is operated by moving handle **IN** to open (to allow air into the firebox) or **OUT** to control or close off air into firebox. (See Figure 10).
4. Plug power cord into a 115V AC outlet if optional motor is being used. Do not run power cord under unit or in high traffic areas.
5. Place crumpled pieces of newspaper in stove. Light it and close door. Ensure that stove draws properly through primary draft.

**NOTE: Do not use grate or elevate fire. Build wood fire directly on inner bottom of fire box.**

6. Check for smoke leaks around the door.
7. Open door and check for smoke escaping from front of stove. Smoking usually indicates a defective or poorly positioned chimney. Some chimneys with a marginal draft can be preheated by lighting newspaper and holding it near open damper with a poker or fire tong. Once chimney heats up, a proper draft can usually be obtained.

If a thorough review of Troubleshooting Guide in manual does not reveal the problem, contact your dealer for assistance.



## **CAUTION**

**THE UNIT IS PAINTED WITH A SPECIALLY FORMULATED HIGH TEMPERATURE PAINT THAT CURES DURING THE FIRST TWO OR THREE FIRINGS. YOU MAY NOTICE A SLIGHT SMOKING EFFECT AND AN ODOR OF BURNING PAINT WHEN YOU BUILD THE FIRST FIRES. THIS IS NORMAL AND IS NOT A CAUSE FOR ALARM. IN SOME CASES, THESE FUMES WILL ACTIVATE A SMOKE ALARM. OPENING A WINDOW NEAR THE UNIT WILL ALLOW THESE FUMES TO ESCAPE. DO NOT BUILD A LARGE, ROARING FIRE UNTIL THIS CURING IS COMPLETE OR HEATER FINISH MAY BE DAMAGED.**

The connector and/or chimney should be inspected at least once a month during heating season to determine if a creosote buildup has occurred.

## **CAUTION**

**NEVER USE GASOLINE, GASOLINE-TYPE LANTERN FUEL, KEROSENE, CHARCOAL LIGHTER FLUID OR SIMILAR LIQUIDS TO START OR "FRESHEN UP" A FIRE IN THE HEATER. KEEP ALL SUCH LIQUIDS WELL AWAY FROM THE STOVE WHEN IT IS IN USE. ALL FLUIDS OF THIS TYPE GIVE OFF VOLATILE FUMES AND CAN AND WILL EXPLODE!! DON'T TAKE A CHANCE WITH THE SAFETY OF YOUR HOME AND FAMILY.**

## SECTION III

# PRE-FAB INSERT INSTALLATION

The Model 74 has been tested with the following UL listed manufactured Pre-Fab Fireplaces:

Heatilator	Security
Tempco	Preway
Marco	FMI
Woodside	Majestic

The Model 74 will fit any of models that are large enough to accept them.

**NOTE:** A full chimney liner is required in a Zero Clearance or pre-fab fireplace.

**NOTE:** The ash lip, smoke baffle and smoke shelf may be removed if necessary to provide room for these models. Any other alteration to unit will void ALL New Buck Corporation responsibility and liability. The warning label below supplied with stove must be attached to the back of fireplace.

Except for the “notes” above, please follow the instructions for Masonry Insert Installation including Minimum Clearances for stove and floor protector in Section II.

**NOTE:** When installing trim panels DO NOT COVER ANY EXITING LOUVERS OR AIR OPENING IN PRE-FABRICATED FIREPLACE.

**WARNING:** This fireplace must be restored to its original condition for safe use, if the fireplace insert is removed.

# SECTION IV

## RESIDENTIAL FREESTANDING INSTALLATION

Select an installation location that will give best airflow from front of heater to remainder of the home.

### PREPARING STOVE FOR INSTALLATION

1. Inspect unit for any obvious physical damage.
2. Plug power cord into a 115V AC outlet to test motor and fan. Do not run power cord under unit or in high traffic areas.
3. Check primary air draft control to ensure that it slides freely.(See Figure 12).
4. Remove any items from within the firebox. Spread a dropcloth on floor behind heater. Next, tilt heater so that back is on drop cloth.
5. **(Leg Kit):** If legs are to be used, obtain four legs, attach legs to holes in bottom of unit with bolts and washers supplied with leg kit. (See Figure 12).
6. **(Pedestal Kit):** If pedestal kit is being used and out side air is required for residential free standing installation (see page 25 Out Side Air Installation). Open freestanding kit and obtain stand. Place stand against bottom of heater (angle side to heater). Center stand front to back and also center stand left and right. Mark screw locations on bottom of stove through outer holes of stand mounting angles. Set stand aside and drill four 7/32" holes in heater bottom. Then mount stand to bottom of heater with screws provided. (See Figure 13).
7. Obtain four (4) 3/16" self-tapping screws and secure stand to heater.
8. Reposition heater to upright position.

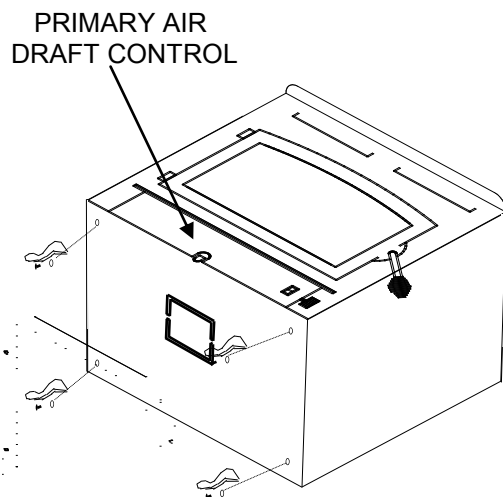

Figure 12

### HOLES FOR MOUNTING PEDESTAL

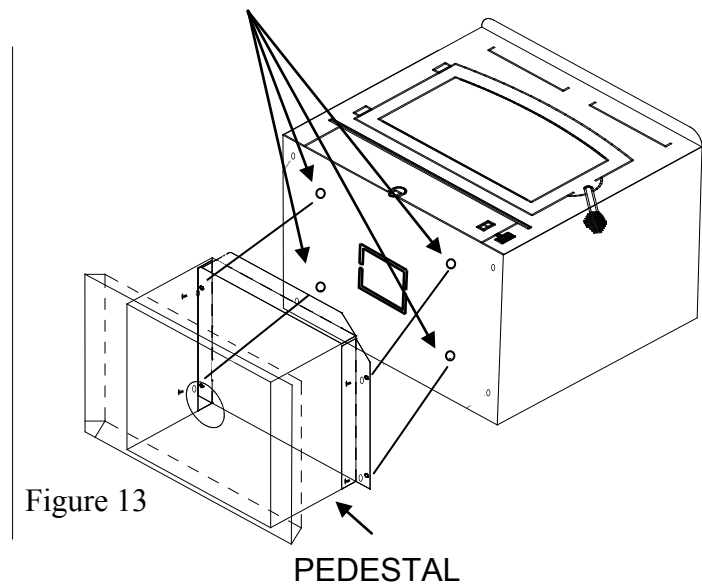

Figure 13

# Chimney

This model is designed for connection to any listed 2100° UL103 HT chimneys and parts. Follow chimneys manufacturer's instructions carefully.

This room heater must be converted to (1) a chimney complying with the requirements for Type HT chimneys in the Standard for chimneys, Factory-Built, Residential, Type and Building Heating Appliance, UL 103, or (2) a code approved masonry chimney with a flue liner.

## Floor Protection:

When installing freestanding heater, a floor protector must be use. Floor protector must be 3/8" minimum thickness non-combustible material or equivalent.

### How to use alternate materials and how to calculate equivalent thickness

An easy means of determining if a proposed alternate floor protector meets requirements listed in the appliance manual is to follow this procedure:

1. Convert specification to R-value:
  - R-value is given—no conversion is needed.
  - K-factor is given with a required thickness (T) in inches:  
C-factor is given:  $R=1/C$
2. Determine the R-value of the proposed alternate floor protector.
  - Use the formula in step (1) to convert values not expressed as "R"
  - For multiple layers, add R-values of each layer to determine the overall R-value.
3. If the overall R-value of the system is grater than the R-value of the specified floor protector, the alternate is acceptable.

#### Example:

The specified floor protector should be 3/4" thick material with a K-factor of 0.84.  
The proposed alternate is 4" brick with a C-factor of 1.25 over 1/8" mineral board with a K-factor of 0.29.

Step (a): Use formula above to convert specification to R-value.  $R= 1/K \times T = 1/0.84 \times .75 = 0.893$

Step (b): Calculate R of proposed system. 4" brick of  $C=1.25$ , therefore  $R_{brick} = 1/C = 1/1.25 = 0.80$  1/8" mineral board of  $K = 0.29$ , therefore  $R_{min.bd.} = 1/0.29 \times 0.125 = 0.431$

Step (c): Compare proposed system R of 1.231 to specified R of 0.893. Since proposed system R is greater than required , the system is acceptable.

Definitions:

$$\text{Thermal conductance} = C = \frac{\text{Btu}}{(\text{hr})(\text{ft}^2)(\text{°F})} = \frac{\text{W}}{(\text{m}^2)(\text{°K})}$$

$$\text{Thermal conductance} = K = \frac{(\text{Btu})(\text{inch})}{(\text{hr})(\text{ft}^2)(\text{°F})} = \frac{\text{W}}{(\text{m})(\text{°K})} = \frac{(\text{Btu})}{(\text{hr})(\text{ft})(\text{°F})}$$

$$\text{Thermal conductance} = R = \frac{(\text{ft}^2)(\text{hr})(\text{°F})}{\text{Btu}} = \frac{(\text{m}^2)(\text{°K})}{\text{W}}$$

Install in accordance with 24 CFR, Part 3280 (HUD).

# CAUTION

**SPECIAL METHODS ARE REQUIRED WHEN PASSING THROUGH A WALL OR CEILING. SEE INSTRUCTIONS AND BUILDING CODES. DO NOT CONNECT THIS UNIT TO A CHIMNEY FLUE SERVING ANOTHER APPLIANCE.**

## DETERMINING CHIMNEY LOCATION

**A. CEILING EXIT (USING SINGLE WALL (minimum 24ga.) pipe and 2100° UL 103 HT type chimney system listed with manufacturer in this section of manual.)**

1. Suspend a plumb bob from ceiling above unit so that weight is hanging in center of flue exit. (A small weight on a string will serve as a plumb bob). Mark ceiling where string is suspended to locate center of chimney. (See Page 16, Figure 14).
2. After locating center of hole, install ceiling support box, chimney flashing and rain cap, per chimney manufacturer's instructions.

Now connect stove and ceiling support box using #24 ga. minimum blue or black steel connector pipe (**DO NOT USE GALVANIZED PIPE**). Connect each section so crimped end faces downward and secure each section to each other using at least three (3) sheet metal screws or rivets. Also use three (3) sheet metal screws to fasten pipe to collar on heater. (See Page 16, Figure 14).

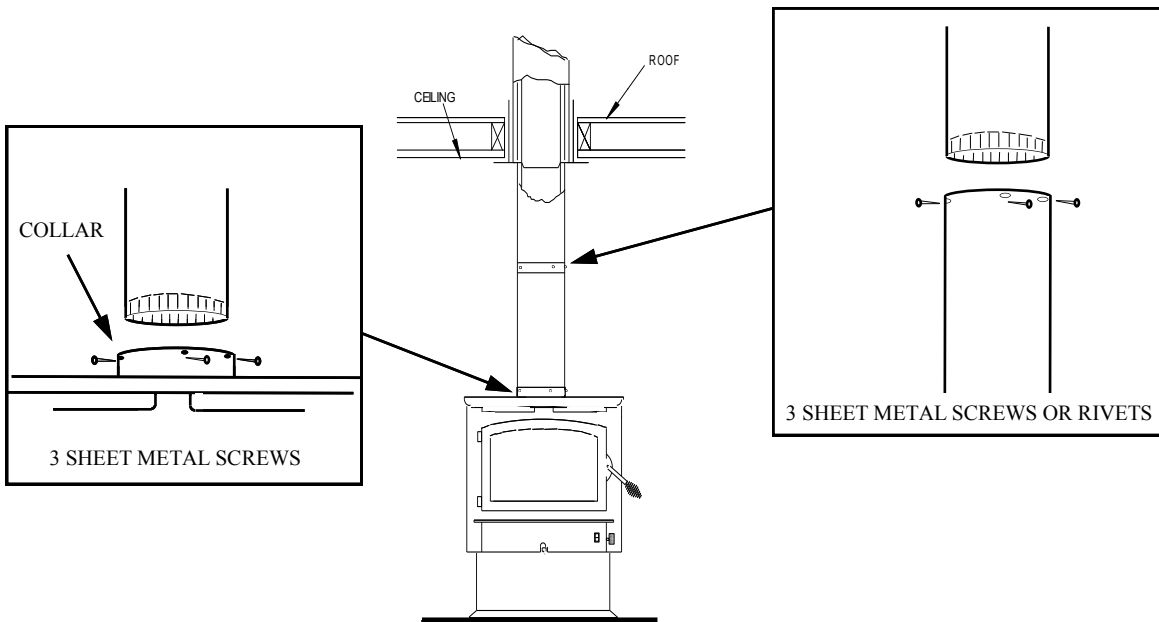

Figure 14

ATTIC

18" MIN.

CEILING

CENTER LINE  
OF ELBOW

Page 15

"TEE" BOX ASSEM.

WALL PASS-THROUGH CONNECTOR

MARK PLUMB LINE

WALL

## B. Wall Exit Into Metal Tee-Box

1. Mark plumb line on wall directly behind center of heater. (See Figure 15).

**NOTE:** When using 24# ga. minimum blue or black steel pipe, maintain 18" between pipe and ceiling. (See Figure 15).

**NOTE:** Floor protector must be under horizontal pipe exit (See Figure 18, Page 20).

ROOF

2. Place vertical portion of heater pipe and elbow in position and project a point onto Plumb line level with center of elbow.

3. Measure up so there will be at least 1/4" rise per foot of horizontal connector pipe, maintaining clearances to ceiling as noted in (Figure 15). This will give you center of hole for chimney penetration.

4. After locating center of penetration, install tee-box and chimney, as per chimney manufacturer's specifications.

5. Connect chimney connector to tee-box using #24 ga. minimum blue or black steel connector pipe. **DO NOT** use galvanized pipe. Connect each section so the crimped end faces downward and secure each section to each other using three (3) sheet metal screws or rivets. (See page 15 Figure 14).

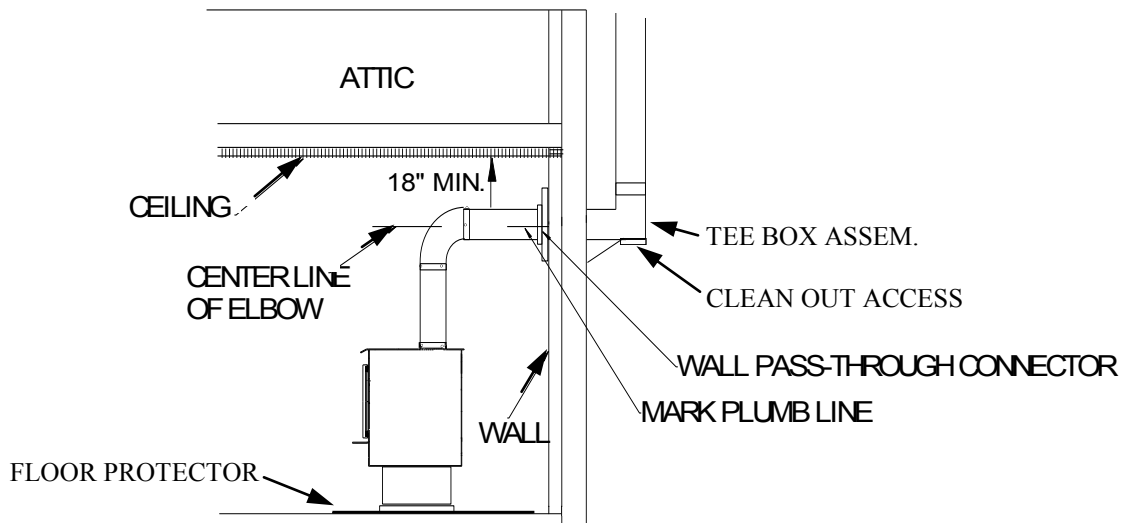

Figure 15

### C. Wall Exit Into Masonry Flue (Using Single Wall Pipe)

1. Before connecting these units to a masonry chimney, determine that masonry flue pass-through connector thimble meets NFPA-211 Code and local building codes and is a minimum of 18" from ceiling. If connector thimble does not meet these codes, the pass-through connector must be modified. (See Figure 16)

**NOTE:** Floor protector must be under horizontal pipe exit (See Figure 18, Page 20).

Co  
(a  
(t

In ad  
shoul

**EXC**  
A thi  
perm:

2. O  
us  
(a

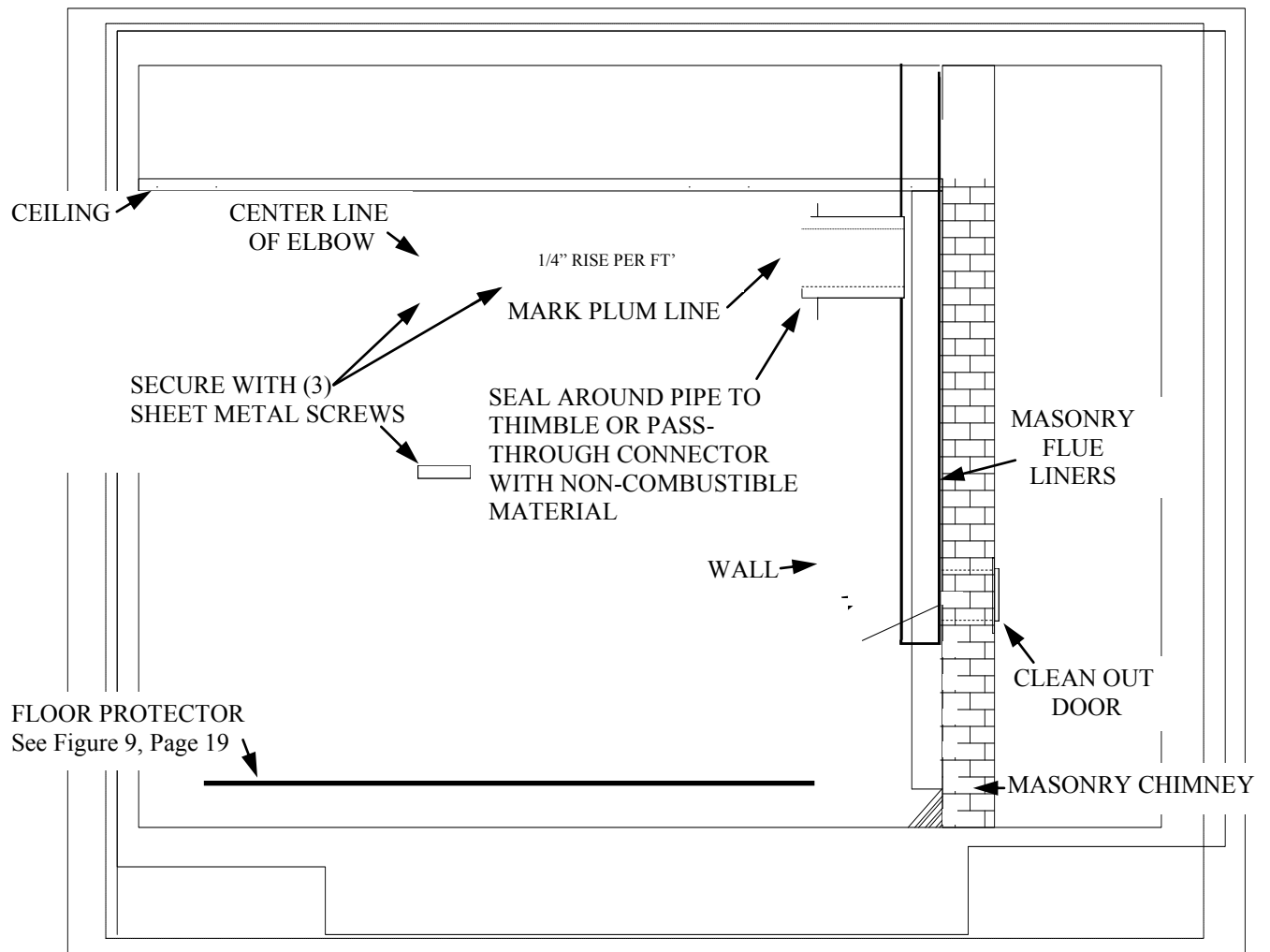
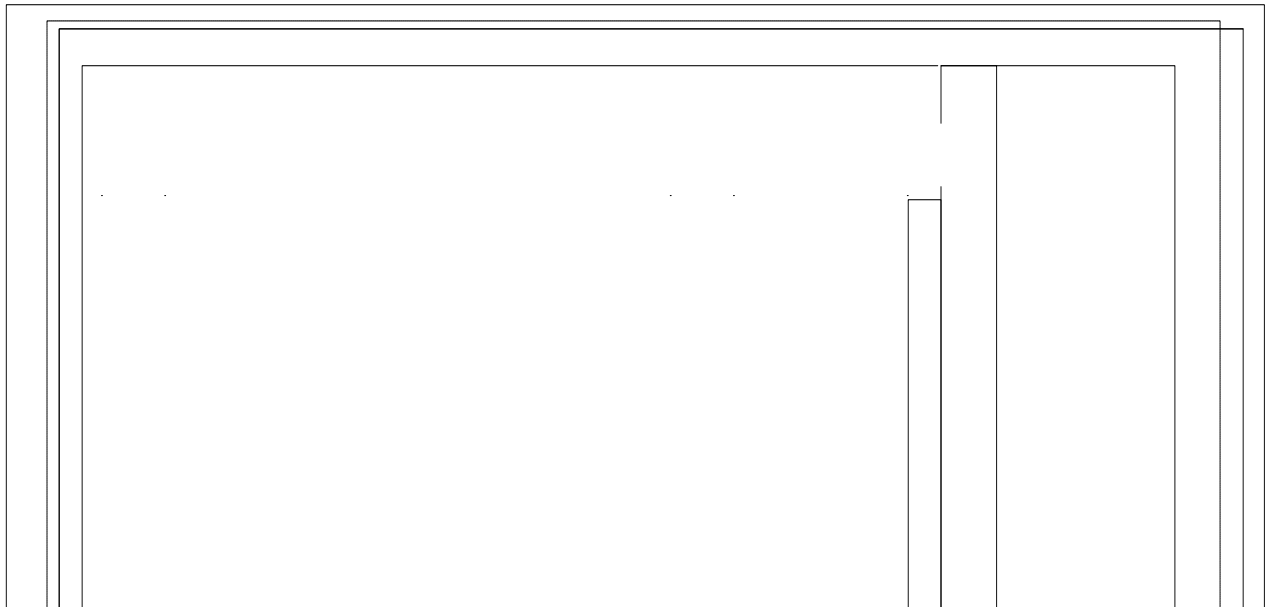

## D. Ceiling Exit-Close Clearance

1. Suspend a plumb bob from ceiling above unit so that weight is hanging in center of flue exit (A small weight on a string will serve as a plumb bob). Mark ceiling where string is suspended to locate center of chimney hole.
2. After locating center of hole, install ceiling support box, chimney flashing and rain cap.
3. Install Double Wall Connector and close clearance chimney systems, per manufacturers written instructions. See stove manufacturers list of tested pipes (See Below).

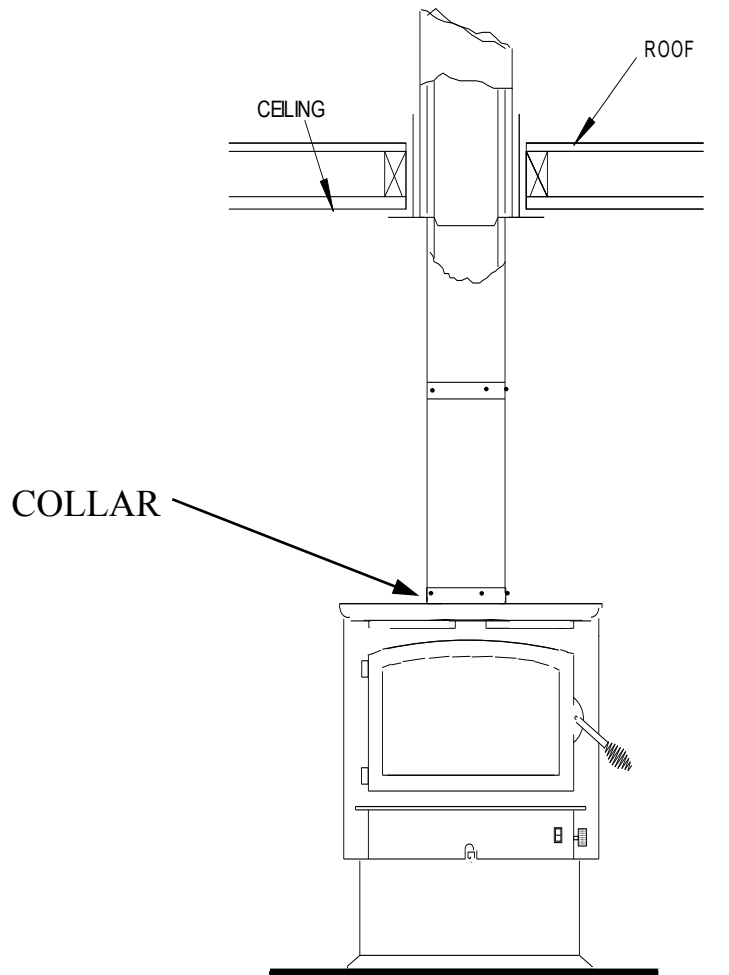

Figure 17

**This unit may be installed using the following double wall close clearance chimney systems:**

- (1) 6" Simpson Dura-Vent double wall chimney connector "Type DVL" and 6" Simpson Dura-Vent 2100° HT. "Type DP" chimney. (2) 6" Security Type DL double wall connector and 6" Security Type "ASHT" High Temp Chimney. (3) 6" Selkirk Metal Bestos Model "DS" double wall connector- 6" Selkirk Metal Bestos Model SSII Type HT Chimney System. (4) 6" Metal Fab Type "DW" double wall connector- 6" Metal Fab 2100 HT chimney. (5) 6" Air Jet. (6) Jakes Evans. For minimum clearances (See pages 20,21,22).

**18" MIN.**

**CEILING**

### Alcove Installation Clearances

Alcove installation must use 6" Double Wall Connector and 6" Type 2100° UL 103 HT Pipe listed for close clearance reduction. For measurements and minimum clearances (See page 24).

**CENTER LINE  
OF ELBOW**

**"TEE" BOX ASSEMBLY**



## FINAL CHECK

1. Recheck specified clearances.
2. Remove all foreign material from firebox area.
3. Open primary air draft.
4. Plug power cord into a 115V AC outlet when using with optional motor. Do not run power cord under unit or in high traffic areas.
5. Place crumpled pieces of newspaper in stove. Light it and close door. Ensure that stove draws properly through primary draft.
6. Check for smoke leaks around door.

### CAUTION

**Open door and check for smoke escaping from front of stove. Smoking usually indicates a defective or poorly positioned chimney. Some chimneys with a marginal draft can be preheated by lighting newspaper and holding it near open damper with a poker or fire tong. Once chimney heats up, a proper draft can usually be obtained.**

If a thorough review of Troubleshooting Guide in manual does not reveal problem, contact your dealer for assistance.

### CAUTION

**The unit is painted with a specially formulated high temperature paint that cures during first two or three firings. You may notice a slight smoking effect and an odor of burning paint when you build first fires. This is normal and is not a cause for alarm. In some cases, these fumes will activate a smoke alarm. Opening a window near unit will allow these fumes to escape. DO NOT build a large, roaring fire until this curing is complete or the heater finish may be damaged.**

# CLEARANCES FOR MODEL 74 MINIMUM CLEARANCES TO COMBUSTIBLES RESIDENTIAL / SINGLE WALL CONNECTOR WITHOUT OPTIONAL CLOSE CLEARANCE SHIELDS AND PIPE SHIELD

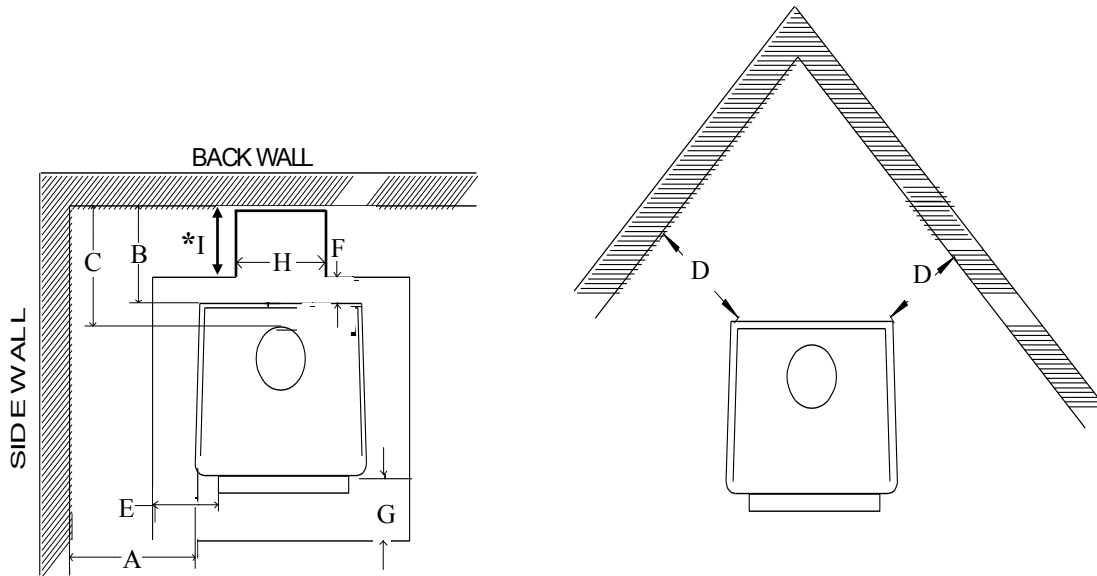

Figure 18

	A	B	C	D	E	F	G	H	*I
MODEL 74	25"	8"	10.5"	8"	8"	6"	20"	10"	FULL LENGTH PIPE TO WALL

**NOTE:** All clearances are to combustibles using single wall pipe without optional close clearance shields and pipe shield, minimum floor protector. Clearances above may be reduced. Follow **NFPA-211** codes if available or follow instructions on next page.

\* For wall exit, floor protector must be under horizontal pipe full length of pipe. There must be 2" on each side of pipe. Maintain 18" between pipe and ceiling. (See Figure 18, measurements H & \*I).

# CLEARANCES FOR MODEL 74 MINIMUM CLEARANCES TO COMBUSTIBLES RESIDENTIAL / PERMANENTLY LOCATED MANUFACTURED HOME, DOUBLE WALL OR SHIELDED SINGLE WALL CONNECTOR WITH OPTIONAL CLOSE CLEARANCE SHIELDS AND PIPE SHIELD

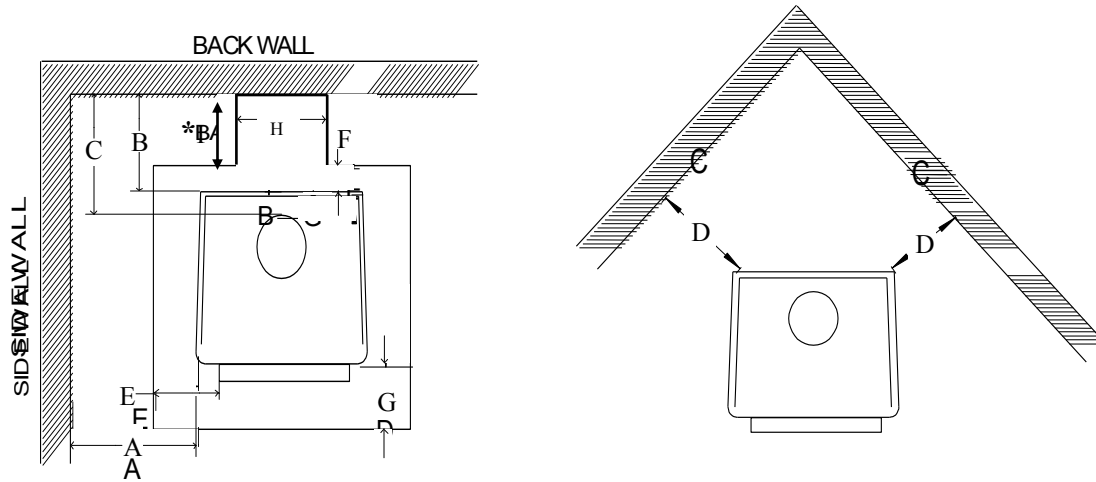

Figure 19

	A	B	C	D	E	F	G	H	*I
MODEL 74	23"	4"	6.5"	4"	8"	6"	20"	10"	FULL LENGTH PIPE TO WALL

**NOTE:** All clearances are to combustibles with double wall or shielded single wall pipe with optional close clearance shields and pipe shield, minimum floor protector.

\* For wall exit, floor protector must be under horizontal pipe full length of pipe. There must be 2" on each side of pipe. Maintain 18" between pipe and ceiling.  
(See Figure 19, measurements F & \*I).

**CLEARANCES FOR MODEL 74  
 MINIMUM CLEARANCES TO COMBUSTIBLES  
 RESIDENTIAL / PERMANENTLY LOCATED  
 MANUFACTURED HOME, DOUBLE WALL OR  
 SHIELDED SINGLE WALL  
 CONNECTOR WITHOUT OPTIONAL CLOSE  
 CLEARANCE SHIELDS**

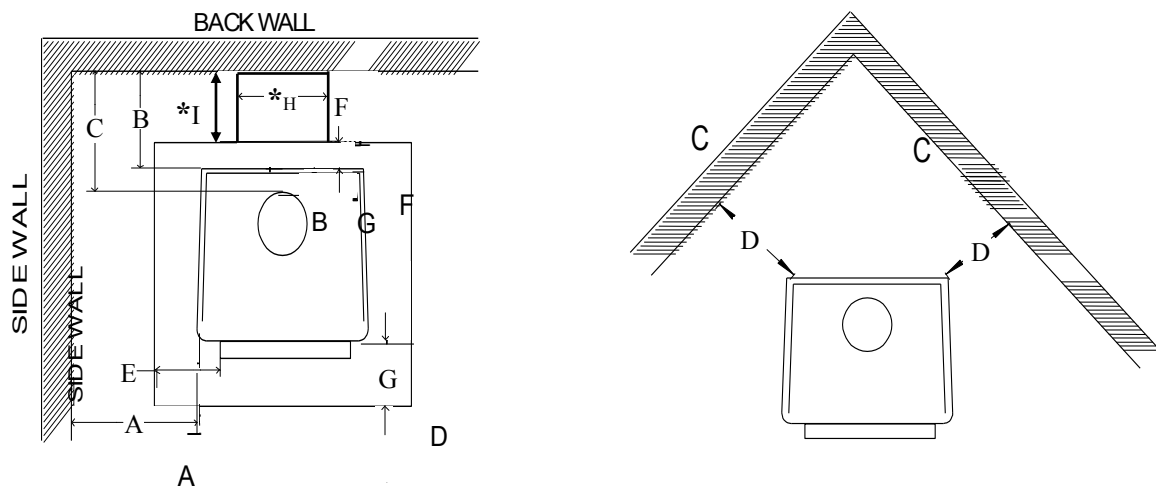
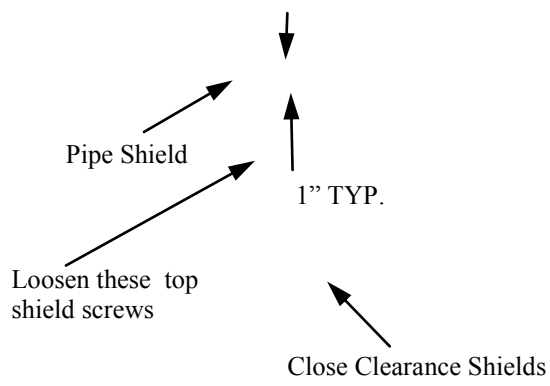

Figure 20

	A	B	C	D	E	F	G	*H	*I
MODEL 74	25"	4"	6.5"	4"	8"	6"	20"	10"	FULL LENGTH PIPE TO WALL

**NOTE:** All clearances are to combustibles using double or shielded single wall pipe without close clearance shields and pipe shield, minimum floor protector.

\* For wall exit, floor protector must be under horizontal pipe full length of pipe. There must be



Installation of (Optional) Pipe Shield

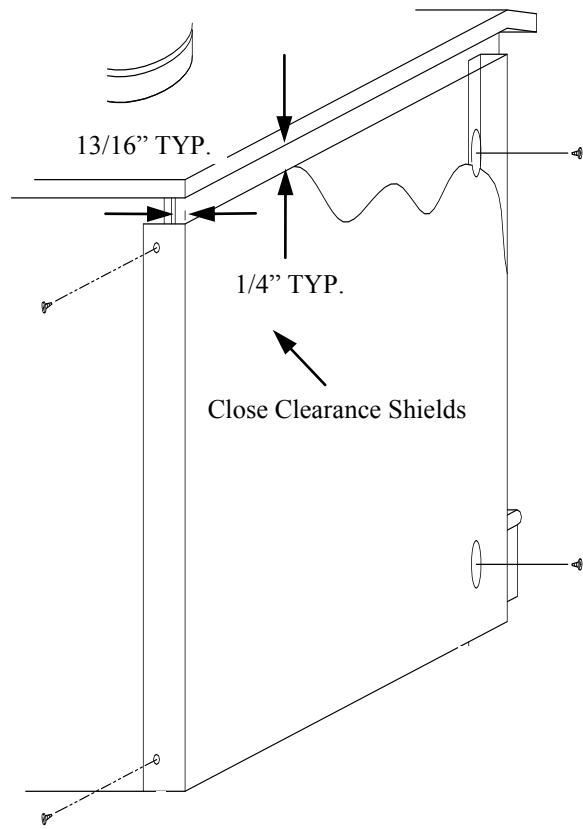

Installation of (Optional) Close Clearance Shields

# CLEARANCES FOR MODEL 74 ALCOVE INSTALLATION DOUBLE WALL OR SHIELDED SINGLE WALL CONNECTOR WITH OPTIONAL CLOSE CLEARANCE SHIELDS AND PIPE SHIELD

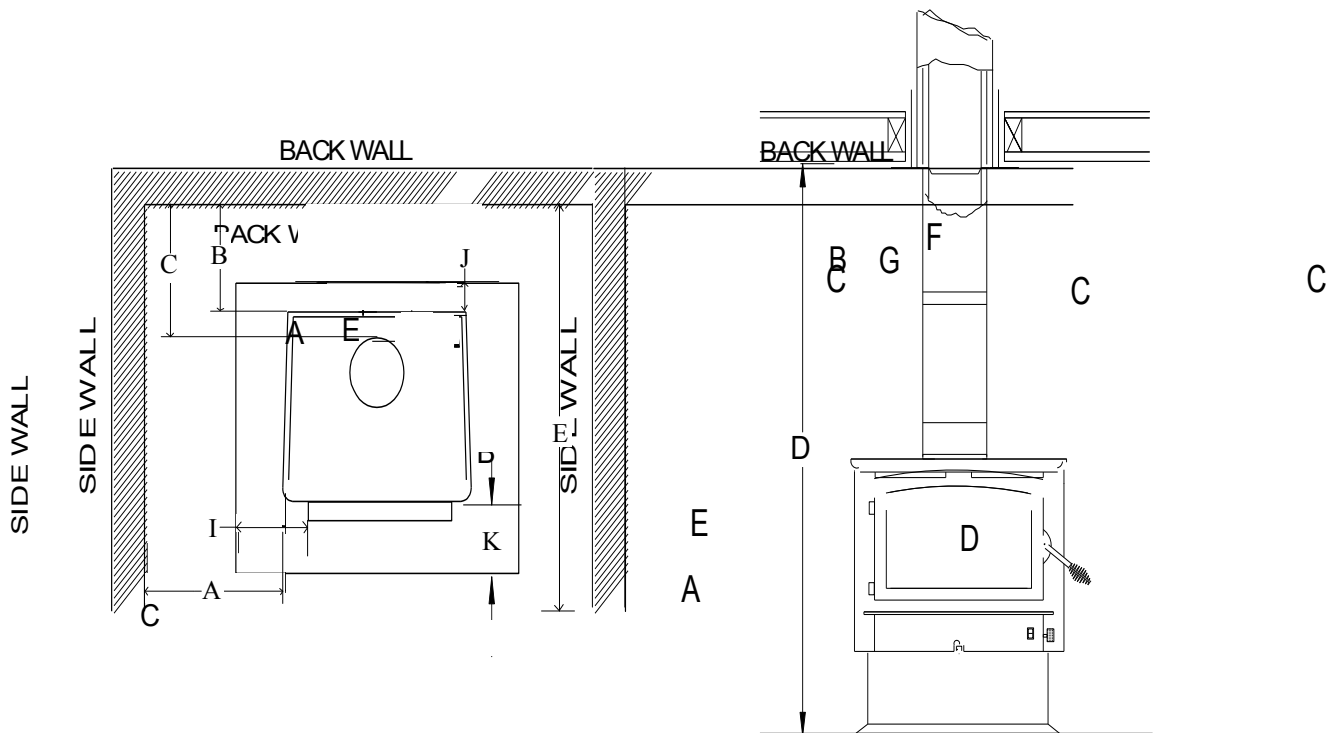

Figure 22

	A	B	C	D	E	I	J	K
MODEL 74	23"	4"	6.5"	84"	36"	8"	6"	20"

**NOTE:** All clearances are to combustibles using double wall or shielded single wall pipe and optional close clearance shields and pipe shield only, minimum floor protector. (See Figure 22).

# SECTION V

## FREESTANDING PERMANENTLY LOCATED MANUFACTURED HOME INSTALLATION

### Floor Protection:

When installing freestanding heater, a floor protector must be used. Floor protector must be 3/8" minimum thickness non-combustible material or equivalent.

#### How to use alternate materials and how to calculate equivalent thickness

An easy means of determining if a proposed alternate floor protector meets requirements listed in the appliance manual is to follow this procedure:

1. Convert specification to R-value:
  - R-value is given—no conversion is needed.
  - K-factor is given with a required thickness (T) in inches:
  - C-factor is given:  $R=1/C$
2. Determine the R-value of the proposed alternate floor protector.
  - Use the formula in step (1) to convert values not expressed as "R"
  - For multiple layers, add R-values of each layer to determine the overall R-value.
3. If the overall R-value of the system is greater than the R-value of the specified floor protector, the alternate is acceptable.

#### Example:

The specified floor protector should be 3/4" thick material with a K-factor of 0.84.

The proposed alternate is 4" brick with a C-factor of 1.25 over 1/8" mineral board with a K-factor of 0.29.

Step (a): Use formula above to convert specification to R-value.  $R= 1/K \times T = 1/0.84 \times .75 = 0.893$

Step (b): Calculate R of proposed system. 4" brick of  $C=1.25$ , therefore  $R_{brick} = 1/C = 1/1.25 = 0.80$  1/8" mineral board of  $K = 0.29$ , therefore  $R_{min.bd.} = 1/0.29 \times 0.125 = 0.431$

Step (c): Compare proposed system R of 1.231 to specified R of 0.893. Since proposed system R is greater than required, the system is acceptable.

#### Definitions:

$$\text{Thermal conductance} = C = \frac{\text{Btu}}{(\text{hr})(\text{ft}^2)(\text{°F})} = \frac{W}{(\text{m}^2)(\text{°K})}$$

$$\text{Thermal conductance} = K = \frac{(\text{Btu})(\text{inch})}{(\text{hr})(\text{ft}^2)(\text{°F})} = \frac{W}{(\text{m})(\text{°K})} = \frac{(\text{Btu})}{(\text{hr})(\text{ft})(\text{°F})}$$

$$\text{Thermal conductance} = R = \frac{(\text{ft}^2)(\text{hr})(\text{°F})}{\text{Btu}} = \frac{(\text{m}^2)(\text{°K})}{W}$$

Install in accordance with 24 CFR, Part 3280 (HUD).

## TOOLS FOR INSTALLATION

This model is designed for connection to any 2100° UL 103 HT chimneys. Follow chimney manufacturers instructions carefully.

Drop cloth, 3/32" Metal drill bit, 5/16" magnetic socket chuck adapter, 5/16" wrench (box or socket) or adjustable wrench, Jigsaw with masonry, metal and wood blades

**WARNING: DO NOT INSTALL IN A SLEEPING ROOM.**

## PREPARING STOVE FOR INSTALLATION

1. Remove protective plastic wrapping from unit, inspect unit for any obvious physical damage.
2. Plug power cord into a 115V AC outlet to test motor and fan when optional motor is being used. Do not run power cord under unit or in high traffic areas.
3. Check primary air draft control to ensure that it slides freely.(See Figure 23).
4. Remove any items from within firebox. Spread a dropcloth on floor behind heater. Next, tilt heater so that back is on drop cloth.
5. **(Leg Kit):** If legs are to be used, obtain four legs, attach legs to holes in bottom of unit with bolts and washers supplied with leg kit. (See Figure 23).
6. **(Pedestal Kit):** If pedestal kit is being used and out side air is required see below, *Out Side Air Installation*. Open freestanding kit and obtain stand. Place stand against bottom of heater (angle side to heater). Center stand front to back and also center stand left and right. Mark screw locations on bottom of stove through outer holes of stand mounting angles. Set stand aside and drill four 7/32" holes in heater bottom. Before attaching heater to the stand, take a large flat screwdriver or pliers and remove 2" x 2" knockout on bottom of unit. (See Figure 24).
7. Obtain four (4) 3/16" self-tapping screws and secure stand to heater. (See Figure 24).
8. Reposition heater to upright position.

PRIMARY AIR  
DRAFT CONTROL

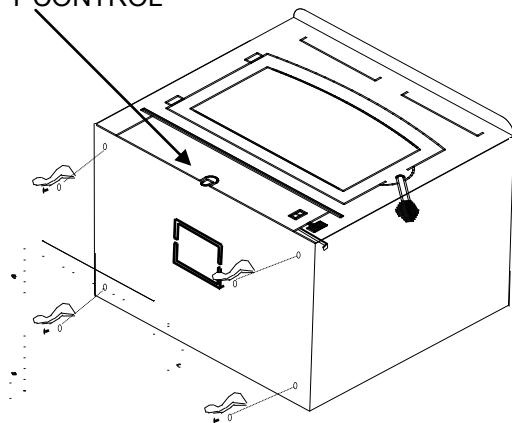

Figure 23

HOLES FOR MOUNTING PEDESTAL

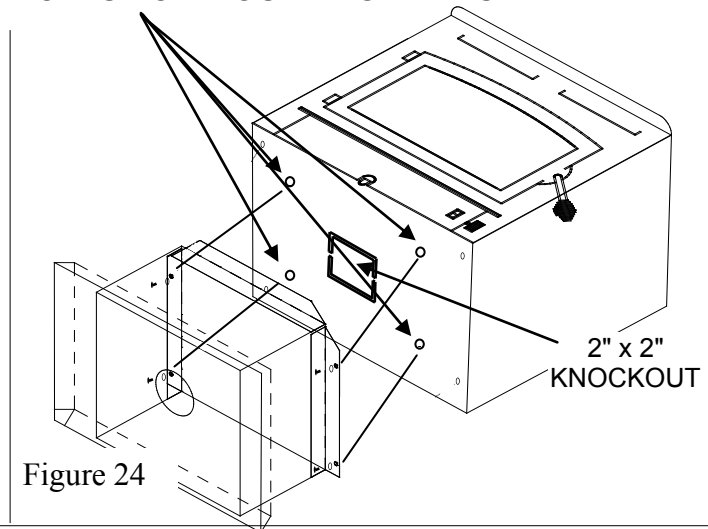

Figure 24

## Out Side Air Installation

### CAUTION

**THE STRUCTURAL INTEGRITY OF MOBILE HOME FLOOR MUST BE MAINTAINED. (MOVE OPENING AND/OR REPOSITION HEATER LOCATION IF NECESSARY).**



1. Select an installation location that will give best airflow from front of heater to remainder of home.
2. Place protective floor pad in position. For minimum floor protection (See Page 25).
3. Place unit on pad making sure minimum clearance specifications are met. For minimum clearance to combustibles (See Page 21, Page 22).
4. Lightly mark with a pencil the location of pedestal on protective pad.
5. Next, remove four (4) screws holding the heater to stand. Position heater out of the way of installation area.
6. Check that pedestal stand is still aligned with marks on protective pad, now mark outside air opening in bottom of pedestal stand on to pad.
7. Mark center line of outside air opening. Set stand aside for now.
8. Cut a 4 1/4" diameter hole in pad and continue through floor.

### **CAUTION!!**

**The structural integrity of the home floor must be maintained. (Move opening and/or reposition heater location if necessary).**

9. Now, reposition pedestal stand and set on pad being sure to line stand up with reference marks.
10. Using an electric drill and 3/8" masonry bit, drill four (4) holes in protective pad using holes in bottom of pedestal stand as a guide. Be careful to drill only through pad and not into floor. Change bit to a 1/4" metal bit and drill through floor.
11. Using four (4) 3/8" x 1-1/2" lag bolts provided, secure pedestal stand and pad to floor of home.

### **CAUTION:**

**IF A THICK FLOOR PROTECTOR IS USED, YOU MAY HAVE TO USE LONGER LAG BOLTS.**

12. Obtain outside air duct from box in pedestal kit marked FA P21B.
13. Slip duct down through the 4-1/4" hole until face of outside air duct contacts bottom of pedestal.
14. Secure outside air duct to inside bottom of pedestal using the four (4) #10x1 screws provided. (See Figure 25).
15. Set heater back onto stand and resecure using screws.
16. NOTE: If home is underpinned, you must duct through underpin as shown. (See Figure 26).

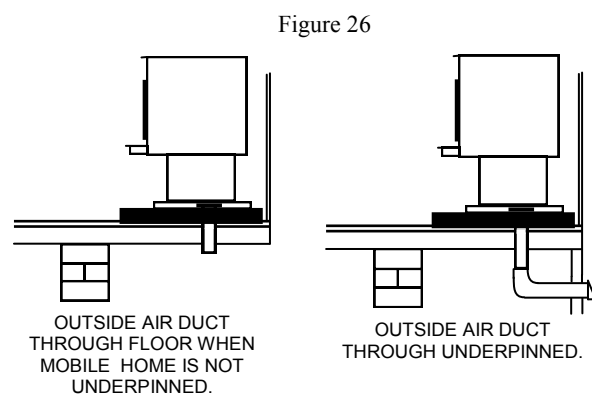
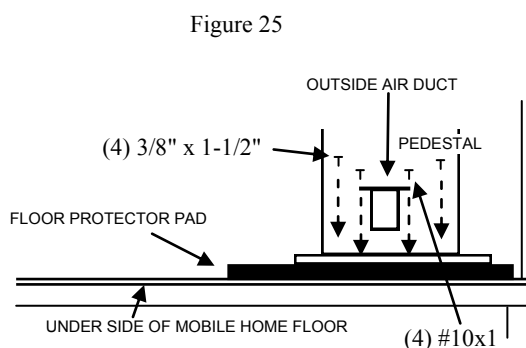

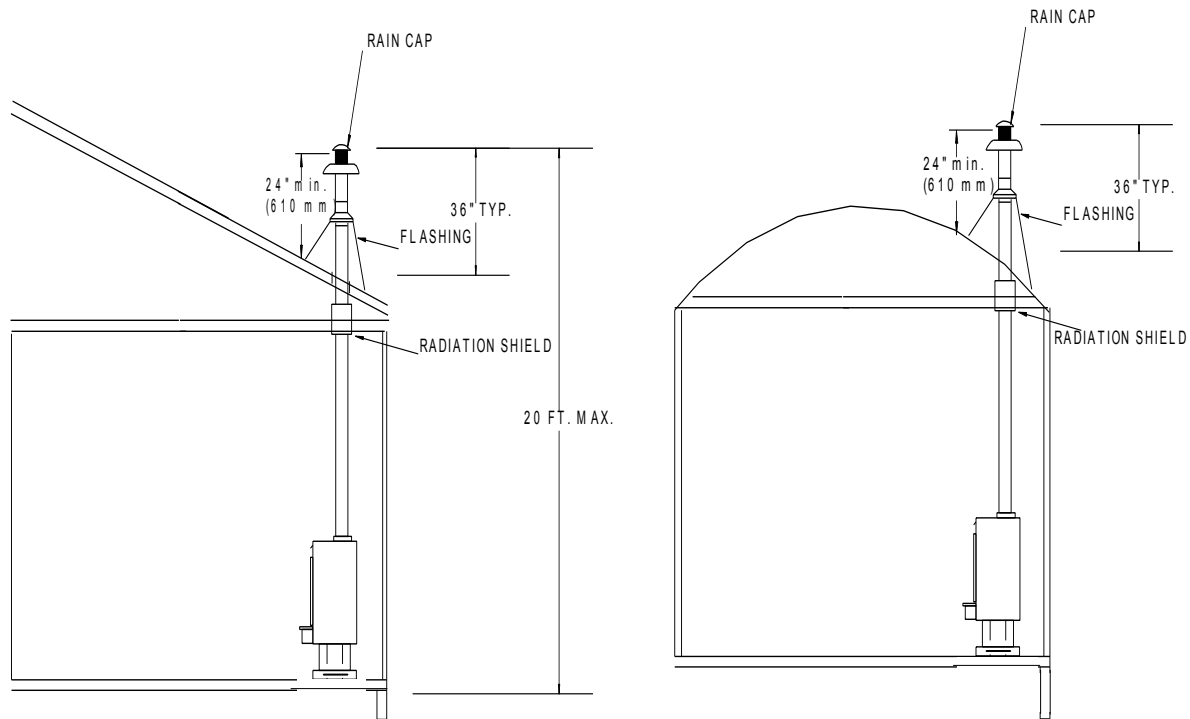

Figure 27

**For ceiling exit using close clearance listed chimney**

1. Suspend a plumb bob from ceiling above unit so that weight is hanging in center of flue exit. (A small weight on a string will serve as a plumb bob). Mark ceiling where string is suspended to locate center of chimney hole.
2. After locating center of hole install ceiling support box, chimney, flashing and rain cap using listed 2100° UL 103 HT chimney only. Only use pipe listed in this manual.

**CAUTION**

**REFER TO CHIMNEY MANUFACTURER'S INSTRUCTIONS FOR ASSEMBLY AND DISASSEMBLY OF CHIMNEY PARTS. BE SURE TO FOLLOW CHIMNEY INSTRUCTIONS FOR PROPER CLEARANCES TO COMBUSTIBLE AND PROPER AIR SPACING REQUIRED.**

3. Add additional pipe until both of the following are met: (See Figure 27).
  - (a) Chimney pipe is 3 feet higher than roof at the point where it penetrates roof.
  - (b) Chimney pipe height is at least 2 feet higher than any part of roof within 10 feet of chimney.

4. Next, install a New Buck Corporation chimney connector to flue of heater or use 3 “ELL” brackets and secure to top of heater and pipe.
5. Using single wall chimney connector, connect heater to chimney by following manufacturer's installation instructions exactly. (See Figure 28).

NOTE: CRIMPED END OF PIPE  
DOWN AND INSIDE OF PIPE  
BLOW IT.

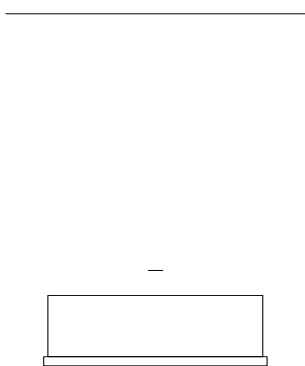

Figer 28

## FINAL CHECK

1. Recheck specified clearances.
2. Remove all foreign material from firebox area.
3. Open primary air draft.

**NOTE:** Plug power cord into a 115 VAC outlet. (If optional motor is being used.) Route cord to prevent damage to cord insulation from heat and sharp objects. Keep cord out of way of traffic to prevent damage caused by tripping, etc.

4. Plug power cord into a 115V AC outlet when using with optional motor. Do not run power cord under unit or in high traffic areas.
5. Place crumpled pieces of newspaper in stove. Light it and close door. Ensure that stove draws properly through primary draft.
6. Check for smoke leaks around door.
7. Open door and check for smoke escaping from front of stove. Smoking usually indicates a defective or poorly positioned chimney. Some chimneys with a marginal draft can be preheated by lighting newspaper and holding it near open damper with a poker or fire tong. Once chimney heats up, a proper draft can usually be obtained.

If a thorough review of Troubleshooting Guide in manual does not reveal problem, contact your dealer for assistance.

### CAUTION

**THE UNIT IS PAINTED WITH A SPECIALLY FORMULATED HIGH TEMPERATURE PAINT THAT CURES DURING FIRST TWO OR THREE FIRINGS. YOU MAY NOTICE A SLIGHT SMOKING EFFECT AND AN ODOR OF BURNING PAINT WHEN YOU BUILD FIRST FIRES. THIS IS NORMAL AND IS NOT A CAUSE FOR ALARM. IN SOME CASES, THESE FUMES WILL ACTIVATE A SMOKE ALARM. OPENING A WINDOW NEAR UNIT WILL ALLOW THESE FUMES TO ESCAPE. DO NOT BUILD A LARGE ROARING FIRE UNTIL THIS CURING PROCESS IS COMPLETE OR HEATER FINISH MAY BE DAMAGED.**

## SECTION VI

# WOOD HEATER SAFETY

Certain safety hazards are inherent in any wood heater installation. You should be aware of these so that a safe and proper installation can be made.

1. **FAULTY CHIMNEY:** An older masonry chimney should be thoroughly checked to be sure there are no holes or weak spots which could allow sparks or hot gases to escape.
2. **HEAT CONDUCTION:** Placing combustible materials too close to a heater or chimney can be a fire hazard.

By keeping these particular hazards in mind as you install and use your room heater you can ensure a safe, reliable installation.

The chimney and chimney connector should be inspected once every two months. Any build-up of soot should be removed to prevent risk of a chimney fire. To remove chimney or chimney connector: remove screws or fasteners, remove pipe and clean with steel brush, replace chimney or chimney connector and replace screws and/or fasteners.

### CAUTION

**NEVER USE GASOLINE, GASOLINE TYPE LANTERN FUEL, KEROSENE, CHARCOAL LIGHTER FLUID OR SIMILAR LIQUIDS TO START OR "FRESHEN UP" A FIRE IN THE HEATER. KEEP ALL SUCH LIQUIDS WELL AWAY FROM THE STOVE WHEN IT IS IN USE. ALL FLUIDS OF THIS TYPE GIVE OFF VOLATILE FUMES AND CAN AND WILL EXPLODE!! DON'T TAKE A CHANCE WITH THE SAFETY OF YOUR HOME AND FAMILY.**

**CAUTION:** Never remove ashes from heater with blower running.

**DISPOSAL OF ASHES:** Ashes should be placed in a metal container with a tight fitting lid. The closed container of ashes should be placed on a non-combustible floor or on the ground, well away from all combustible materials. If ashes are disposed of by burial in soil or otherwise locally dispersed, they should be retained in closed container until all cinders have thoroughly cooled.

**CREOSOTE-FORMATION AND NEED FOR REMOVAL:** When wood is burned slowly, it produces tar and other organic vapors, which combine with expelled moisture to form creosote. The creosote vapors condense in relatively cool chimney flue of a slow-burning fire. As a result, creosote residue accumulates on flue lining. When ignited this creosote makes an extremely hot fire

## SECTION VII OPERATION/EFFICIENCY

1. "To maximize the efficiency of your wood stove make sure it is sized properly for the space you plan to heat. An oversized stove will burn and be forced to burn at a lower and dirtier burn rate. Consult with your dealer for sizing your stove correctly.
2. Use dry, seasoned wood only. Recommended fire wood length 16" front to back. Using wet wood will greatly reduce your efficiency.
3. Consult with your installer/dealer to correctly place the stove in your home. An incorrectly placed stove can greatly reduce efficiency.  
Maximizing the efficiency of your stove will heat your house quickly, burn cleaner and use less wood.  
(For best results **use wood that has been split and dried 6-12 months**, See Page 5 bottom picture for stacking wood for drying). **Place wood from front to back position in heater.**

"This wood heater has a manufacturer-set minimum low burn rate that must not be altered. It is against federal regulations to alter this setting or otherwise operate this wood heater in a manner inconsistent with operating instruction in this manual."

**NOTE:** "Following all suggested operating and maintenance procedures will help minimize visual emissions.

The following steps will serve as a guide for operating your stove.

### **BUILDING A FIRE**

1. Open door.
2. Open Primary Air Control. The primary air intake draft control is located at center bottom of hearth. It is operated by moving handle **in** to open (to allow air into firebox) or **out** to control or close off the firebox.
3. Twist two pieces of non-colored newspaper into a roll and place them on floor of firebox.  
**NOTE: Do not use grate or elevate fire. Build wood fire directly on inner bottom of fire box.**
4. This model is not designed for use of grates, andirons or other methods of supporting fuel.
5. Lay several pieces of dry kindling on top of newspaper.
6. Place three or four small pieces of firewood, 2"-3" in diameter, on top of kindling.
7. Light newspaper in front. Close and latch door. Don't leave fire unattended at this point. The draft system of heater should start quickly. It may be necessary to preheat chimney to get draft started. To do this, open door and add newspaper to top rear of wood. Light or let this paper ignite and allow to burn while holding the door slightly cracked. Once draft has started, close and lock door. You are over-heating the unit if the chimney and or connector glows red.
8. **NOTE: After embers and a coal bed have been established, load heater with seasoned natural hard wood, placing it front to rear.**

**NOTE: THE FUELING DOOR MUST REMAIN CLOSED DURING OPERATION.**

BURN RATE:	LOW	MED-LOW	MED-HI	HI
AIR SETTINGS:	1/32"	5/32"	9/32"	WIDE OPEN

Your stove is equipped with an automatic thermostat. When stove gets hot enough, thermostat will activate room air blower. Set fan speed on low, when burning on low, med-low or med-high. Set fan speed on high when burning on high.

**NOTE: When refueling or removing ashes turn "OFF" room air blower. Be sure to turn room air blower back on when finished.**

**NOTE: Do not run power cord underneath heater or in walk way or heavy traffic areas.**

## GUIDE TO THE DIFFERENT BURNING QUALITIES OF WOOD

<b>Type of Wood</b>	<b>Ease of Starting</b>	<b>Coaling Qualities</b>	<b>Amount of Sparks</b>
Apple	Poor	Excellent	Few
Ash	Fair	Good	Few
Beech	Poor	Good	Few
Birch	Good	Excellent	Moderate
Cherry	Poor	Excellent	Few
Cedar	Excellent	Poor	Many
Elm	Fair	Good	Very Few
Hemlock	Good	Low	Many
Hickory	Fair	Excellent	Moderate
Locust	Poor	Excellent	Very Few
Maple	Poor	Excellent	Few
Oak	Poor	Excellent	Few
Pine	Excellent	Poor	Moderate

The Main Audubon Society recently charted the heat produced by a wood fire. They noted that heat produced by a wood fire varies greatly with kind of wood burned. Beech is considered best wood for a fire. A cord of well-seasoned Beech will produce as much heat as 169 gallons of fuel oil; Sugar Maple and Red Oak produce as much heat as 166 gallons of fuel oil; followed by White Ash 154; American Elm 130; White Birch 124; and White Pine 94.

# SECTION VI

## MAINTENANCE

### DOOR GASKET REPLACEMENT (COLD HEATER)

To replace deteriorated gaskets, follow these steps to ensure proper installation of gaskets.

1. Obtain proper gaskets and silicone glue from your local dealer.
2. Using pliers, remove any worn and deteriorated gaskets.
3. Using a scraper, wire brush and sandpaper or steel wool, clean glue and gasket residue from door frame.
4. Measure and cut gaskets to length. Care should be taken not to stretch gaskets. What you want is a full and loose gasket weave after attachment to framing.
5. Obtain silicone glue and run a 3/16" bead inside door frame.
6. Obtain gasket (s) and place in gasket channel areas starting at lower right corner, see below. Use a technique which assures that gasket is applied in a loose like manner. **DO NOT STRETCH GASKETS.**
7. After gasket (s) are applied to glue, use your finger and go over all gasket gently pressing gasket to the channel. Use same pressure against gasket so that final result is an evenly applied gasket.
8. Leave door open and allow at least two (2) hours for glue to dry.
9. Once gaskets are checked, heater is ready for use.
10. This should be done annually. Allowing gaskets to deteriorate can cause over firing and shorten burn time.

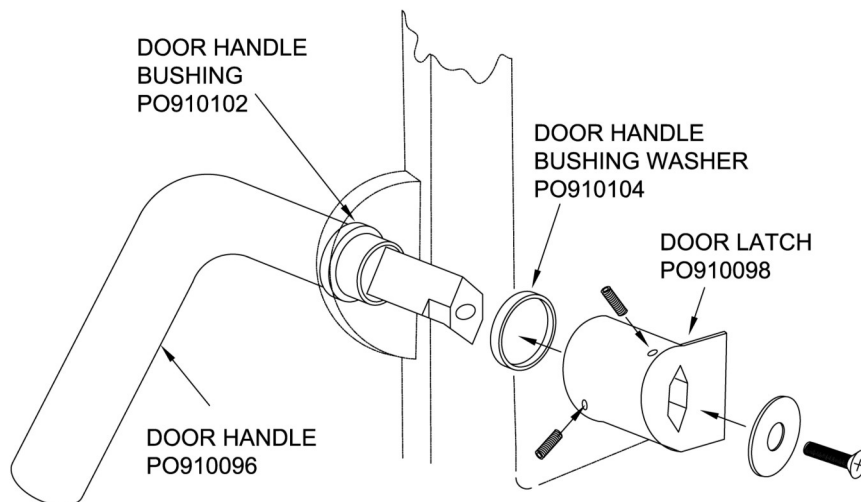
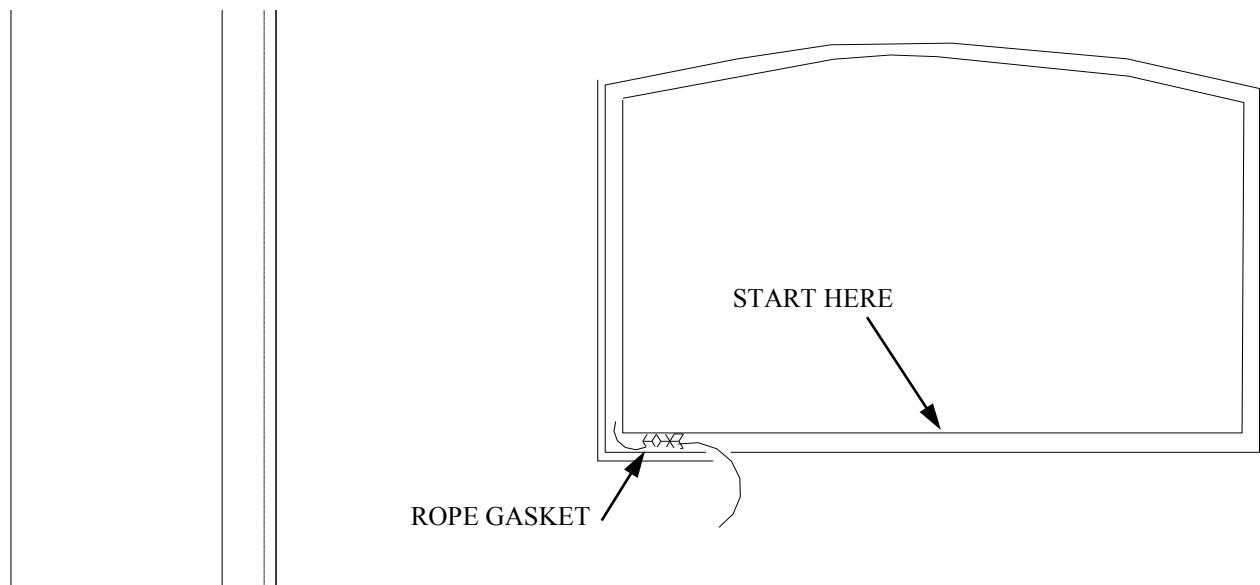



# MAINTENANCE

## BRICK LAYOUT

TOP VIEW

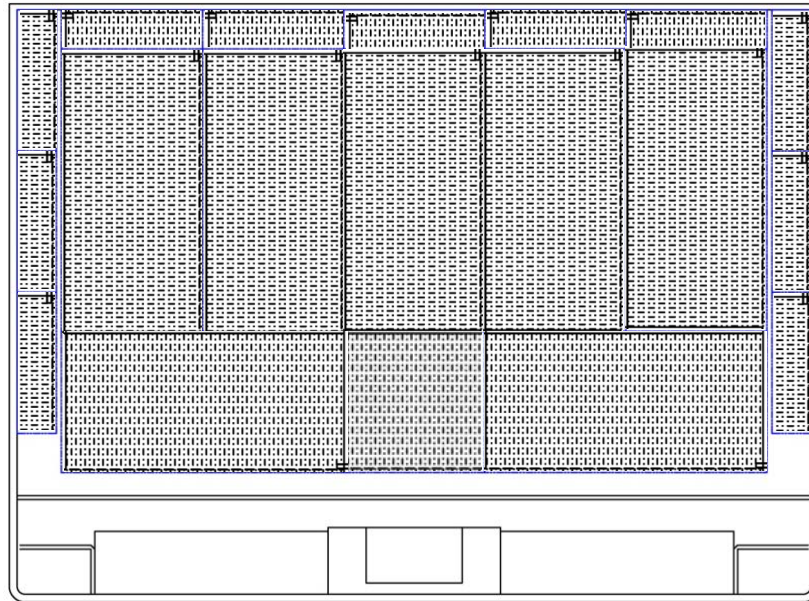

SIDE VIEW

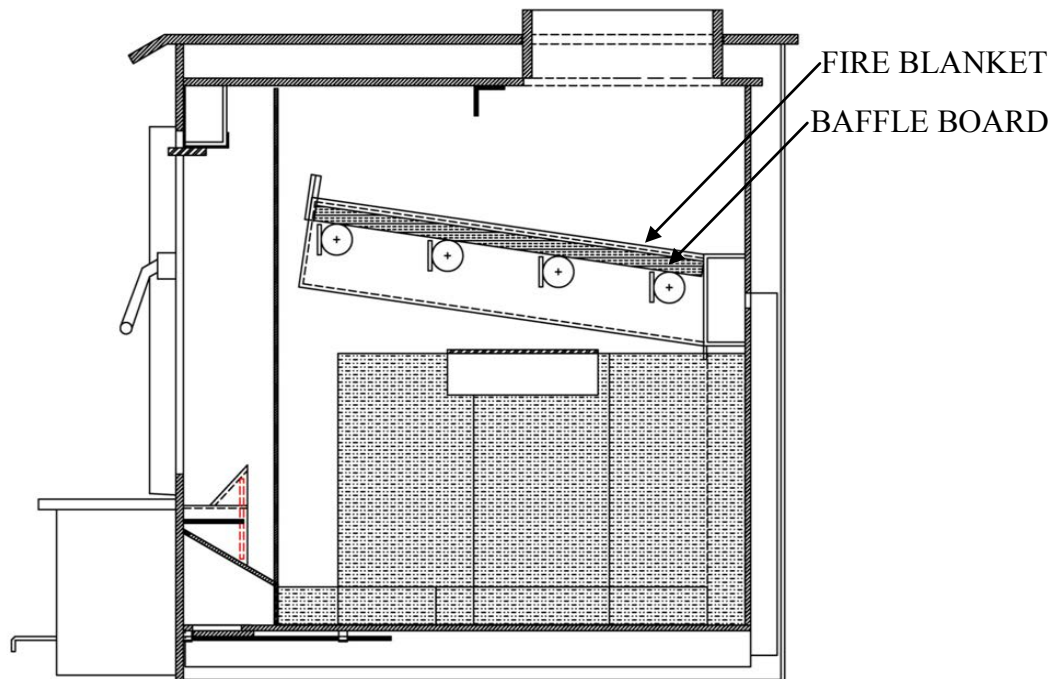

NOTE: “This wood heater needs periodic inspection and repair for proper operation. It is against federal regulations to operate this wood heater in a manner inconsistent with operating instructions in this manual.”

# MAINTENANCE

## SECONDARY AIR TUBES REPLACEMENT

(Replacing secondary air tubes)

### COLD STOVE

1. Unplug heater from 115V AC outlet.
2. Put drop cloth down.
3. Empty ashes.
4. Remove air tube. The (4) secondary air tubes are located in top of burn chamber. On right side of tubes you will find a cotter pin. To remove air tube remove cotter pin and slide tube to left, it will drop down, slide tube to right it should come out. (See Figure 32).
5. When replacing tubes you need to make sure you have ordered the correct tube. (See Page 37) for detailed diagram of tube location and definition. Also See, Replacement Parts (See Page 44).
6. Replace air tube. On one end of tube you will find a hole drilled on both sides through the tube. This end goes to right side. Place tube in left tube holder and slide other end of tube into right side tube holder. Line up through hole in air tube with tube holder bracket and replace cotter pin and bend slightly so it wont fall out.

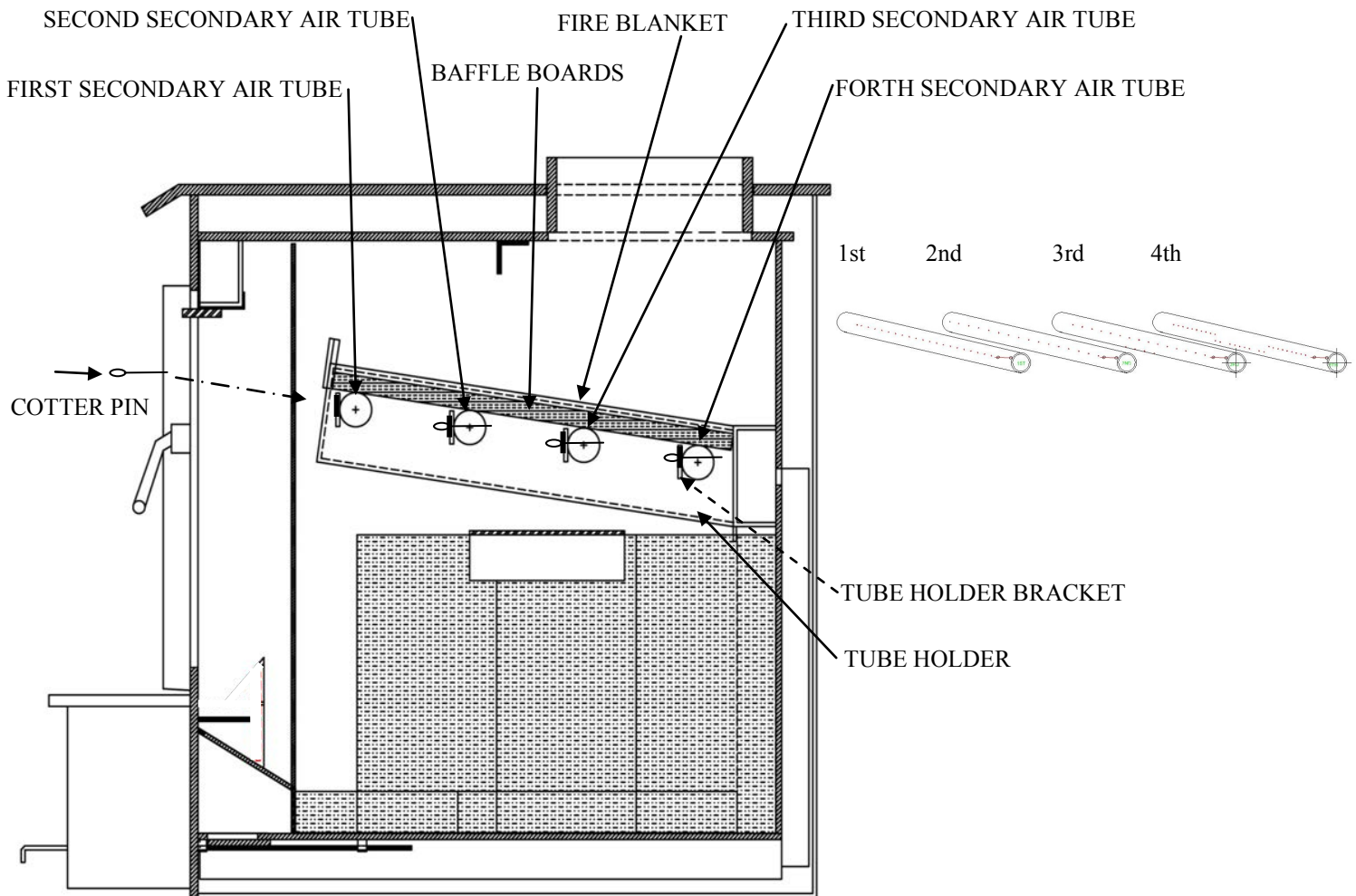

Figure 32

## BAFFLE BOARDS REPLACEMENT

(Replacing baffle board)

### COLD STOVE

1. Unplug heater from 115V AC outlet.
2. Put drop cloth down and empty ashes.
3. Repeat steps 1-5 from above removing 1st tube only.
4. The baffle boards run long ways front to rear. Lift and slide baffle board toward the front. (See Figure 32).
5. Replace baffle board making sure the board is seated on top of air tubes and behind front baffle board holder. After replacing both baffle boards replace front air tube following step 6 from secondary air tube replacement.

# IDENTIFICATION DIAGRAM AND TUBE LOCATION

Note: All tubes have a thru hole on one end of tube for cotter pin, this end of tube inserts into right side tube holder.

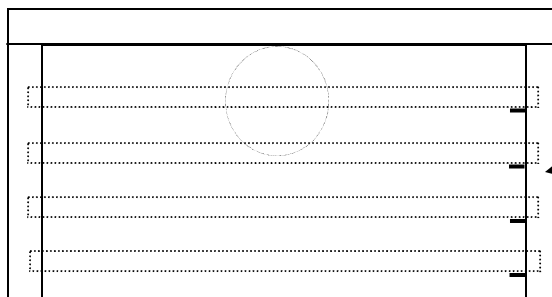
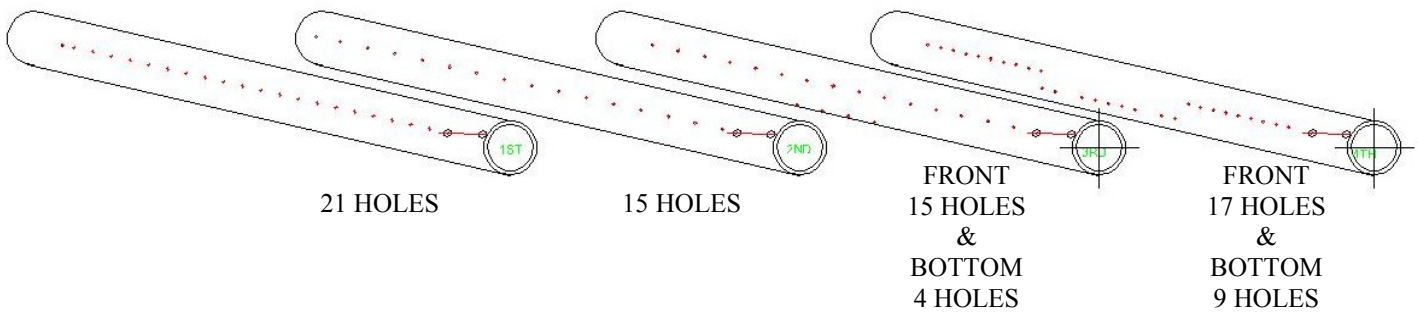
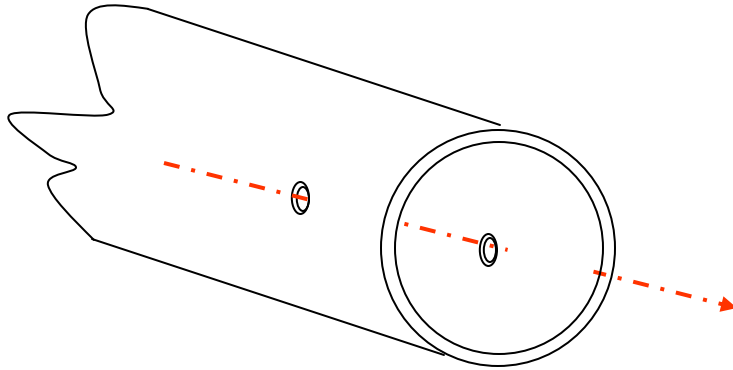

VIEW FROM TOP  
RIGHT SIDE TUBE  
HOLDER

## **OPTIONAL MOTOR ASSEMBLY KIT INSTALLATION INSTRUCTIONS**

- STEP 1. REMOVE ACCESS DOOR PANEL LOCATED AT BOTTOM OF UNIT. YOUR MOTOR ASSEMBLY COMES WITH A BRACKET ALREADY ATTACHED TO MOTOR. ALIGN HOLES IN MOTOR BRACKET WITH HOLES IN MOTOR MOUNT. SECURE BRACKET WITH TWO 1/2" HEX HEAD SCREWS PROVIDED.**
- STEP 2. REMOVE PROTECTIVE BACKING OFF RHEOSTAT INDICATING LABEL AND PLACE HOLE IN CENTER OF LABEL TO LINE UP WITH HOLE IN RIGHT SIDE HEARTH SUPPORT, AS YOU FACE UNIT. PLACE LABEL SO "OFF" POSITION IS AT THE 8 O'CLOCK POSITION AND LOW IS AT THE 4 O'CLOCK POSITION. MOUNT RHEOSTAT BY PLACING IT BEHIND HEARTH SUPPORT WITH WIRES ON BOTTOM SIDE. PLACE PLASTIC STUD THROUGH HOLE IN BRACKET AND SECURE WITH RHEOSTAT MOUNTING NUT. PLACE INDICATOR KNOB ON PLASTIC STUD.**
- STEP 3. REMOVE STRAIN RELIEF COVER FROM HEARTH SUPPORT AND DISCARD. MOUNT POWER CORD STRAIN RELIEF HOLDER IN COVER MOUNTING HOLES. PLACE THERMOSTAT BEHIND "C" CLIP LOCATED UNDER HEARTH TO RIGHT OF MOTOR. USE CABLE TIE TO SECURE LOOSE WIRES.**
- STEP 4. REINSTALL ACCESS DOOR PANEL.**
- STEP 5. PLUG POWER CORD INTO SUPPLY OUTLET. PLACE RHEOSTAT INDICATING KNOB IN DESIRED POSITION. WHEN HEATER REACHES TEMPERATURE, FAN WILL OPERATE AT DESIRED SPEED.**

**NOTE: ROUTE POWER CORD TO PREVENT DAMAGE TO CORD INSULATION FROM HEAT AND SHARP OBJECTS. KEEP CORD OUT OF THE WAY OF TRAFFIC TO PREVENT DAMAGE CAUSED BY TRIPPING, ECT.**

# MOTOR -THERMOSTAT-RHEOSTAT REPLACEMENT

To replace Motor, Thermostat, Rheostat follow steps below.

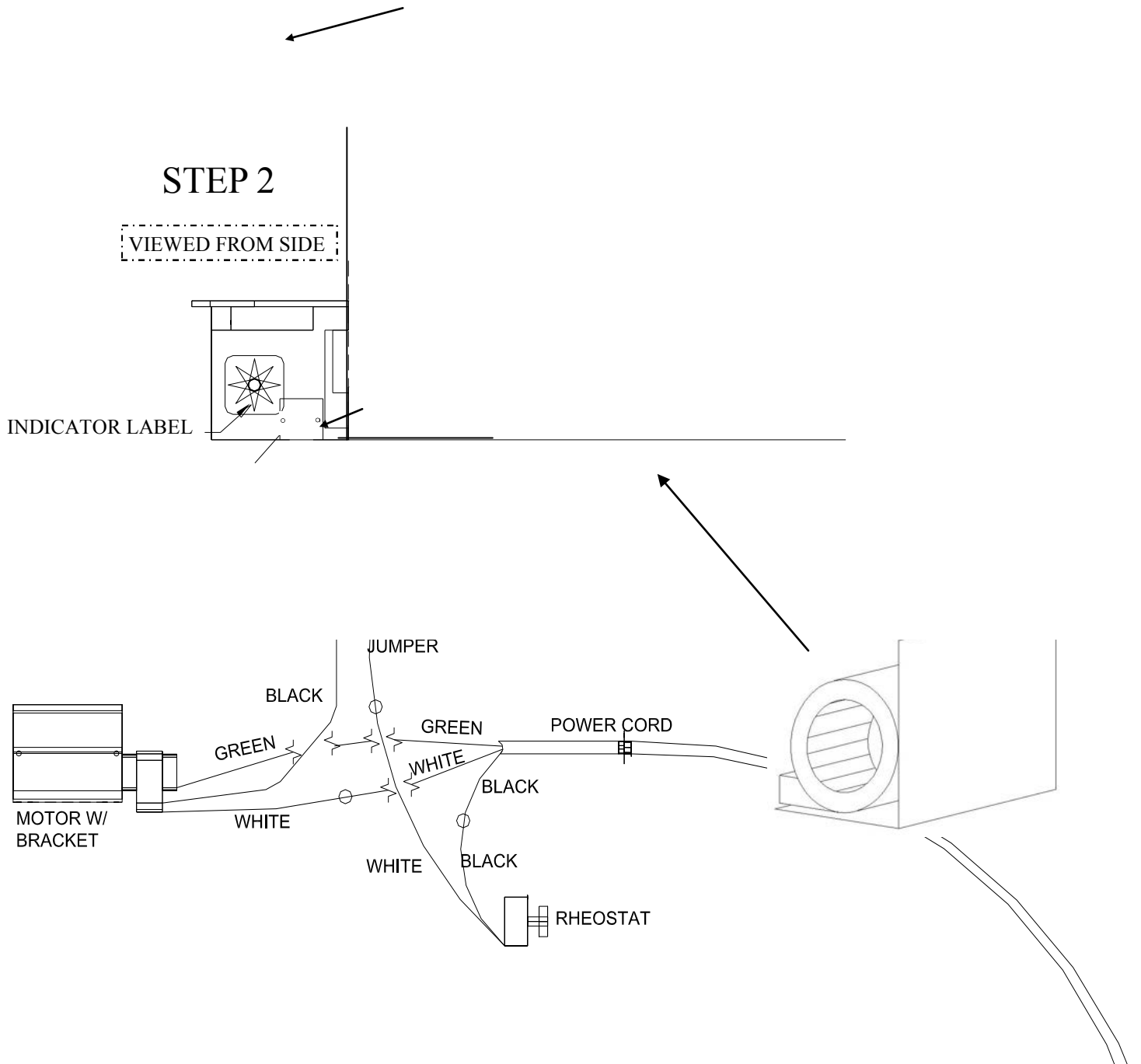

# MAINTENANCE

## CHECK CHIMNEY

- A. Chimney should be inspected twice a year.
- B. The chimney should be cleaned as necessary to remove creosote, soot, leaves, birds' nests, etc.

Before sweeping the chimney a few steps must be done. Put a drop cloth down.

1. Open feed door. The (4) secondary air tubes are located in top of burn chamber. On right side of tubes you will find a carter pin. To remove air tube remove cotter pin and slide tube to left, it will drop down, slide tube to right it should come out, remove (2) front air tubes then gently remove the Baffle Boards with Fire Blanket, set them aside. Remove the (2) rear air tubes.
2. Close feed door for cleaning chimney so debris don't fall out feed door while cleaning chimney.
3. Creosote and debris will fall into the bottom of the stove unit from the cleaning.
4. Clean out all the creosote and debris from inside stove unit left from clean sweeping chimney.
5. Before replacing air tubes (See page 37. Tube Identification/Tube Location order). On one end of tube you will find a hole drilled on both sides through the tube. This end goes to right side. Place rear 4th tube in left tube holder and slide other end of tube into right side tube holder. Line up through hole in air tube with tube holder bracket and replace cotter pin and bend slightly so it wont fall out. Place 3rd tube in following same directions as the 4th tube. Replace the (2) Baffle Boards and Fire Blanket onto 3rd and 4th tube, making sure the board and fire blanket is seated on top of air tube and behind front baffle board holder. Baffle boards run long ways front to rear. Fire blanket needs to be placed on top of tube holders and top of rear manifold. In order to get a good seal. After replacing both baffle boards and fire blanket, replace 2nd air tube and 1st.

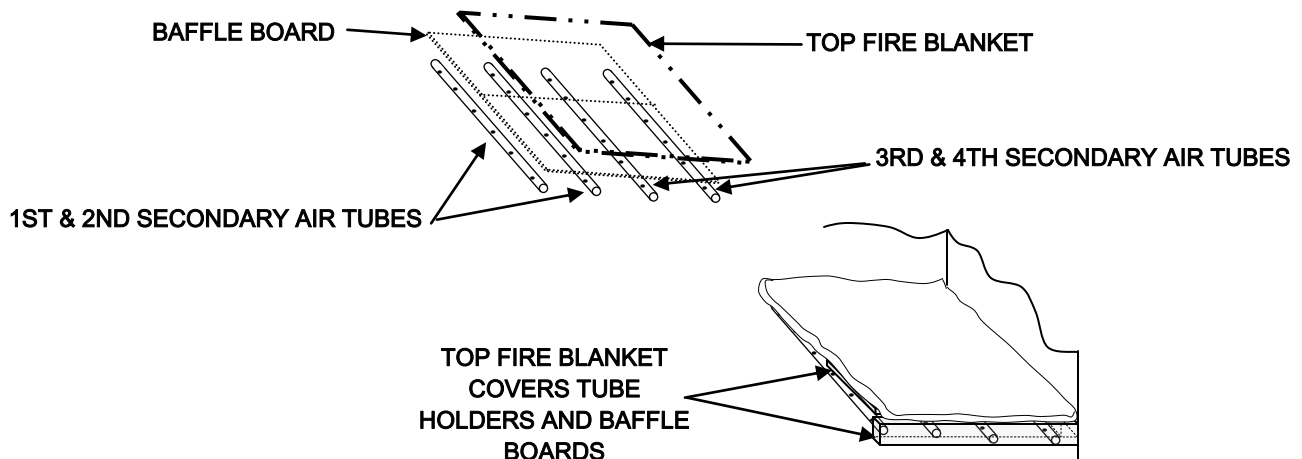

**⚠ NOTE:** A chimney cap should be installed to prevent moisture from entering chimney, to prevent sparks and burning materials from escaping chimney and to keep birds and foreign materials from entering.

**\* NOTE:** Some areas may require an approved spark arrestor.

## **CLEANING THE HEATER**

- A. The heater should not be cleaned with any type of detergent as most all detergents have an oil base and cannot be painted over.
- B. The heater should be lightly sanded with fine sandpaper or steel wool, then repainted or touched up with high temperature paint.
- C. If the heater is located in a moist or damp location, check thoroughly for signs of condensation during times when heater is not in use.
- D. When heating season is over, heater should be cleaned out completely with a wire brush or cloth to help eliminate ash and burned wood smell.

## **CARE OF GLASS DOOR**

The glass door on your heater permits you to enjoy the beauty of the fire while retaining efficiency of your heater. Although brand of glass used in heater door has well established and recognized heat resistant and strength characteristics, it can be broken through improper care. To achieve maximum utility and safety of your glass door, we advise that you observe following use and safety tips:

1. Inspect glass regularly for cracks or breaks. If you detect a crack or break extinguish fire immediately and return door to your dealer for glass replacement before further use.
2. Do not slam heater door or otherwise impact glass. When closing door, make sure that no logs or other objects protrude to impact against glass.
3. Do not clean glass with materials which may scratch it (such as steel wool) or otherwise damage glass. Scratches on the glass can develop into cracks or breaks.

The glass can be cleaned with a commercial oven cleaner, providing it does not contain abrasives. A build-up on glass that has been there for a considerable length of time can be burned off with a propane torch or straight razor blade. Use protective gloves when using razor.

**SECTION VIII  
TROUBLESHOOTING**

<b>PROBLEM</b>	<b>POSSIBLE CAUSE</b>	<b>SOLUTION</b>
Sluggish Heater	Obstruction in chimney	Check for and remove obstruction
	Improperly sealed trim kit or direct connect kit	(a) Check trim kit gasketing seal to fireplace and gasket as necessary to seal unit and gasket under front bottom of stove, if needed. (b) Check seal if using direct connect and correct.
	Manual damper in chimney is closed	Open manual damper and wire shut with stainless steel wire or remove damper
	Wet or unseasoned wood being burned	Burn dry, natural seasoned hard wood
	Poor chimney draft	Improper chimney height or wrong size flue is being used. Cooler temperatures caused by external chimney
	Improper wood loading	Load wood from front to rear



# TROUBLESHOOTING

(Continued)

PROBLEM	POSSIBLE CAUSE	SOLUTION
High fuel consumption	Improper regulation of draft or inlet air	<ul style="list-style-type: none"> <li>(a) Close inlet air control as much as possible to maintain desired heat output</li> <li>(b) Check gaskets, reinstall fiberglass gasketing round doors and glass as necessary</li> </ul>
	Improper door fitting	Check door gasket, check adjustment of door latch
Backpuffing	Gusts of Wind	<ul style="list-style-type: none"> <li>(a) Smoke shelf in chimney is filled with creosote &amp; ash</li> <li>(b) Chimney may need wind diverter. Raise chimney for better draft</li> </ul>
Smoke rollout when heater door is opened	Wind gusts blowing down the chimney	<ul style="list-style-type: none"> <li>(a) Smoke shelf in chimney is filled with creosote &amp; ash</li> <li>(b) Chimney may need wind diverter. Raise chimney for better draft</li> </ul>
	Opening heater door too fast	Open air control. Crack door for 15 seconds before fully opening door

# REPLACEMENT PARTS MODEL 74

NOTE: For replacement parts use only manufacturer's specified parts.

	Description	Quantity	Part No.
1.	Door Gold	1	MA912651GW
2.	Door Black	1	MA912651GW
3.	Door Pewter	1	MA912651PW
4.	Door Handle	1	PO210092
5.	Retrofit Door Bushing	1	PO210102
6.	Thin Spacer	1	PO910104
7.	Retrofit Door Handle Spacer	1	PO21SPACER
8.	Retrofit Handle Latch	1	PO910106
9.	Door Latch Washer	1	PH316916FW
10.	Door Latch Screw	1	PH102212FUH
11.	Door Roping 3/4"	1	RPFR2LD.750G
12.	Glass Gasket	1	RPTKW197X.875GA
13.	Door Glass	1	PG2124GL
14.	Glass Clips Large	1	PO912651
15.	Glass Clip Screws Hex/Washer Slot Machine Screw 10-32 X 1/2	10	PH103211HWHMC
16.	Spring Handle	1	PO100150
17.	Cotter Pin	4	PH182CPSS
18.	First Secondary Air Tubes	1	PO740021
19.	Second Secondary Air Tubes	1	PO740022
20.	Third Secondary Air Tubes	1	PO740023
21.	Fourth Secondary Air Tubes	1	PO740024
22.	Baffle Board	2	POBPF74
23.	Firebrick	1	PR900050
24.	Hearth Trim Black	1	PO810705-BLK
25.	Primary Air Plate		MF510034
26.	Screws for Primary Air Plate to Air Control Rod Hex/ Washer Slot Machine Screw 10-32 X 1/4	2	PH103214HWHSM
27.	Air Control Rod	1	MF201035
28.	Front Air Control Bracket	1	MF740017
29.	Screws for Front Air Control Bracket to Stove Hex/ Washer Self Drilling Screw 1/4-14 X 1"	2	PH14141TEKP
30.	Spring for Ash Dump	2	PH5162SPRING
31.	Bottom Ash Lid Gasket	1	PO201070
32.	Top Ash Lid Gasket	1	PO201072
32.	Rheostat - <b>Optional</b>	1	PEBC204
34.	Rheostat Knob - <b>Optional</b>	1	PEBC204A
35.	Indicator Label - <b>Optional</b>	1	PEKB9724
36.	Thermostat 110 disc - <b>Optional</b>	1	PE400132
37.	Power Cord - <b>Optional</b>	1	PE400240
38.	Strain Relief - <b>Optional</b>	1	PE400320
39.	Blower Kit - <b>Optional</b>	1	MA5126715
40.	Motor Only - <b>Optional</b>	1	PESBRO84
41.	Close Clearance Shield - <b>Optional</b>	1	MA21SHIELD

**NEW BUCK CORPORATION (NBC)**  
**"LIMITED WARRANTY" FOR THE BUCK STOVE**  
**PLEASE READ THIS WARRANTY CAREFULLY**

**PRODUCTS COVERED**

This warranty covers the new Buck Stove heating unit, so long as it is owned by the original purchaser, including optional and standard accessories purchased at the same time, subject to terms, limitations, and conditions herein set out.

**PRODUCTS NOT COVERED**

This warranty does not cover the following:  
Glass, Refractory Material, Firebrick or Gaskets.

This Warranty will not cover any damage and/or failure caused by abuse or improper installation of the products covered.

**WARRANTY TIME PERIODS**

**(A) Period I**

For one (1) year from the date of purchase, NBC will replace or repair, at its option, any part defective in materials or workmanship. The costs of parts only are included. The customer pays any labor or transportation charges required.

Thereafter,

**(B) Period II**

For the period after the first year from the date of purchase and extending for five (5) years as long as the Buck Stove is owned by the original purchaser, NBC will repair or replace, at its option, any part defective in materials or workmanship, with the exception of: electrical motors, wiring, switches, components, optional and standard accessories and all parts not permanently attached to the heating unit. Parts not permanently attached to the heating unit are defined as those items designed to be removed from the stove, including those removable with common hand tools. The costs of parts only are included. The customer pays any labor or transportation charges required.

**PROCEDURE**

Should you feel that your BUCK STOVE is defective, you should contact any Buck Stove dealer for the name of your nearest authorized Buck Stove service representative, who will instruct you on the proper procedure, depending on which Warranty Time Period (Period I or Period II) applies.



If for any reason you are dissatisfied with the suggested procedures, you may contact us in writing at:

New Buck Corporation  
Customer Service Department  
P. O. Box 69  
Spruce Pine, NC 28777  
Email: info@buckstove.com

## CONDITIONS AND EXCLUSIONS

- (A) Replacement of parts may be in the form of new or fully reconditioned parts, at NBC's option.
- (B) There is no other express warranty. All implied warranties of merchantability and fitness for use are limited to the duration of the Express Warranty.
- (C) New Buck Corporation is not liable for indirect, incidental, or consequential damages in connection with the use of the product including any cost or expense of providing substitute equipment or service during periods of malfunction or non-use.  
Some states do not allow the exclusion of incidental or consequential damages, so the above exclusion may not apply to you.
- (D) All warranty repairs under this warranty must be performed by an authorized Buck Stove service representative. Repairs or attempted repairs by anyone other than an authorized service representative are not covered under this warranty. In addition, these unauthorized repairs may result in additional malfunctions, the correction of which is not covered by warranty.

## OTHER RIGHTS

This warranty gives you specific legal rights, and you may also have other rights, which vary from state to state.

## OWNER REGISTRATION CARD

The attached Owner Registration Card must be completed in its entirety and mailed within 30 days from the date of purchase or from the date of installation, if installed by a factory certified installer, to New Buck Corporation in order for warranty coverage to begin.

**PLEASE NOTE:** The Owner Registration Card must contain the Authorized Buck Stove Dealer Code Number and the Certified Installer's number (if applicable) for warranty coverage to begin.

To be completed by selling distributor/ dealer/ customer:

Name \_\_\_\_\_  
(Last) (First)

Address \_\_\_\_\_

City \_\_\_\_\_ State \_\_\_\_\_ Zip \_\_\_\_\_

*CUSTOMER EMAIL:* \_\_\_\_\_

**MODEL 74** - Serial Number \_\_\_\_\_

Date of Installation: Day \_\_\_\_\_ Month \_\_\_\_\_ Year \_\_\_\_\_

Installer's Name \_\_\_\_\_

Installer's Certification Number \_\_\_\_\_

Dealer's Name \_\_\_\_\_

City \_\_\_\_\_ State \_\_\_\_\_ Zip \_\_\_\_\_



# QUALITY CONTROL SERVICES

LABORATORY EQUIPMENT • SALES • SERVICE • CALIBRATION • REPAIRS  
2340 SE 11<sup>TH</sup> Ave. Portland, Oregon 97214 • Box 14831 Portland, Oregon 97293  
(503) 236-2712 • FAX (503) 235-2535 • www.qc-services.com



PFS Teco  
11785 SE Hwy 212 STE#305  
Clackamas, OR 97015

Report Number: DIRI0182484A0912013i181218

## A2LA ACCREDITED CERTIFICATE OF CALIBRATION WITH DATA

### INSTRUMENT INFORMATION

Item	Make	Model	Serial Number	Customer ID	Location
Scale	Digiweigh	DWP12i 400x.01	82484A0912013i	#050	Lab
Units	Readability	SOP	Cal Date	Last Cal Date	Cal Due Date
lbs	0.01	QC033	12/18/18	6/13/18	12/2019

### FUNCTIONAL CHECKS

SHIFT TEST		LINEARITY		REPEATABILITY		ENVIRONMENTAL CONDITIONS
Test Wt:	Tol:	Test Wt:	Tol:	Test Wt:	Tol:	<input type="checkbox"/> Good <input checked="" type="checkbox"/> Fair <input type="checkbox"/> Poor Temperature: 16.4°C
50	0.05	HB44	HB44	50	0.01	
As-Found:		As-Found:		As-Found:		
Pass: <input checked="" type="checkbox"/>	Fail: <input type="checkbox"/>	Pass: <input checked="" type="checkbox"/>	Fail: <input type="checkbox"/>	Pass: <input checked="" type="checkbox"/>	Fail: <input type="checkbox"/>	
As-Left:		As-Left:		As-Left:		
Pass: <input checked="" type="checkbox"/>	Fail: <input type="checkbox"/>	Pass: <input checked="" type="checkbox"/>	Fail: <input type="checkbox"/>	Pass: <input checked="" type="checkbox"/>	Fail: <input type="checkbox"/>	

### CALIBRATION DATA

Standard	As-Found	As-Left	Expanded Uncertainty
400	399.99	399.99	0.058
300	300.00	300.00	0.058
200	200.03	200.03	0.058
100	100.01	100.01	0.012
50	50.00	50.00	0.012
20	20.00	20.00	0.012

### CALIBRATION STANDARDS

Item	Make	Model	Serial Number	Cal Date	Cal Due Date	NIST ID
Avoirdupois Cast W	Rice Lake	25 and 50lb	PWO990-CA	11/24/17	11/2019	20172265

#### Permanent Information Concerning this Equipment:

12 month calibration cycle.

#### Comments/Information Concerning this Calibration

12/18 - RH = 64%. Adjusted span.

Report prepared/reviewed by: ServiceTech DC Date: 12/28/18

Technician: R. Kauble

Signature:

THIS CERTIFICATE SHALL NOT BE REPRODUCED, EXCEPT IN FULL, WITHOUT THE APPROVAL OF QUALITY CONTROL SERVICES, INC.

The uncertainty is calculated according to the ISO Guide to the Expression of Uncertainty in Measurement and includes the uncertainty of standards used combined with the observed standard deviation of the unit under test. The uncertainty is expanded with a k factor of 2 for an approximate 95% level of confidence. Instruments listed above were calibrated using standards traceable to the National Institute of Standards and Technology (NIST). Calibration data reflect results at the time and location of calibration. Calibration data should be reviewed to insure that the instrument is performing to its required accuracy.

# Dry Gas Meter Calibration

Meter Manufacturer: Apex  
 Model: XC-60-ED  
 Lab ID #: 53  
 Serial #: 1902130  
 Calibration Date: 6/14/2019  
 Calibration Expiration: 12/14/2019  
 Barometric Pressure: 29.97 in. Hg



Reference Standard DGM	
Manufacturer:	Apex
Model:	SK25DA
Lab ID#:	47
Serial #:	1101001
Calibration Expiration Date:	3/13/2020
Calibration $\gamma$ Factor:	0.998

Unit Under Test Previous Calibration	
Date	12/17/2018
$\gamma$ Factor:	1.004
Allowable Deviation ( $\pm 5\%$ ):	0.0502
Actual Deviation:	0.01
Result:	PASS

Calibration Data	Run 1	Run 2	Run 3
Standard DGM Initial Volume (L)	0.000	0.000	0.000
Standard DGM Final Volume (L)	147.373	142.005	143.359
Standard DGM Temperature ( $^{\circ}$ F)	71.0	72.0	72.0
Standard DGM Pressure (in H <sub>2</sub> O)	0.00	0.00	0.0
DGM Initial Volume (ft <sup>3</sup> )	0.000	0.000	0.000
DGM Final Volume (ft <sup>3</sup> )	5.227	5.114	5.224
DGM Temperature ( $^{\circ}$ F)	78.0	85.0	91.0
DGM Pressure (in H <sub>2</sub> O)	2.67	2.00	1.5
Time (min)	33.0	36.0	42.0
Net Volume for Standard DGM (ft <sup>3</sup> )	5.204	5.015	5.063
Net Volume for DGM (ft <sup>3</sup> )	5.227	5.114	5.224
Dry Gas Meter $\gamma$ Factor	1.000	0.998	0.998
$\gamma$ Factor Deviation From Average	1.000	0.998	0.998

Average Gas Meter  $\gamma$  Factor 0.999

Calculations:

- Deviation = |Average value for all runs - current run value|
- $\gamma = [V_{std} \times (\gamma_{std}) \times (P_{bar} + P_{std}/13.6) \times (T_{DGM} + 460)] / [V_{DGM} \times (T_{std} + 460) \times (P_{bar} + P_{DGM}/13.6)]$

Standard Reference Meter is calibrated to NIST traceable standards. Uncertainty of measurement is  $\pm 0.5\%$ .

# Dry Gas Meter Calibration

Meter Manufacturer: Apex  
 Model: XC-60-ED  
 Lab ID #: 54  
 Serial #: 1902133  
 Calibration Date: 6/14/2019  
 Calibration Expiration: 12/14/2019  
 Barometric Pressure: 29.97 in. Hg



Reference Standard DGM	
Manufacturer:	Apex
Model:	SK25DA
Lab ID#:	47
Serial #:	1101001
Calibration Expiration Date:	3/13/2020
Calibration $\gamma$ Factor:	0.998

Unit Under Test Previous Calibration	
Date	12/17/2018
$\gamma$ Factor:	1.000
Allowable Deviation ( $\pm 5\%$ ):	0.05
Actual Deviation:	0.00
Result:	PASS

Calibration Data	Run 1	Run 2	Run 3
Standard DGM Initial Volume (L)	0.000	0.000	0.000
Standard DGM Final Volume (L)	139.967	143.359	139.656
Standard DGM Temperature ( $^{\circ}$ F)	72.0	73.0	75.0
Standard DGM Pressure (in H <sub>2</sub> O)	0.00	0.00	0.0
DGM Initial Volume (ft <sup>3</sup> )	0.000	0.000	0.000
DGM Final Volume (ft <sup>3</sup> )	5.098	5.242	5.114
DGM Temperature ( $^{\circ}$ F)	92.0	93.0	95.0
DGM Pressure (in H <sub>2</sub> O)	2.99	2.02	1.3
Time (min)	30.0	37.0	45.0
Net Volume for Standard DGM (ft <sup>3</sup> )	4.943	5.063	4.932
Net Volume for DGM (ft <sup>3</sup> )	5.098	5.242	5.114

Dry Gas Meter $\gamma$ Factor	0.997	0.995	0.995
$\gamma$ Factor Deviation From Average	0.997	0.995	0.995

Average Gas Meter  $\gamma$  Factor

0.996

Calculations:

1. Deviation = |Average value for all runs - current run value|
2.  $\gamma = [V_{std} \times (\gamma_{std}) \times (P_{bar} + P_{std}/13.6) \times (T_{DGM} + 460)] / [V_{DGM} \times (T_{std} + 460) \times (P_{bar} + P_{DGM}/13.6)]$

Standard Reference Meter is calibrated to NIST traceable standards. Uncertainty of measurement is  $\pm 0.5\%$ .



# Dry Gas Meter Calibration

Meter Manufacturer: Apex  
 Model: Apex-AK-600  
 Lab ID #: 55  
 Serial #: 810016  
 Calibration Date: 6/14/2019  
 Calibration Expiration: 6/14/2020  
 Barometric Pressure: 29.95 in. Hg



Reference Standard DGM	
Manufacturer:	Apex
Model:	SK25DA
Lab ID#:	47
Serial #:	1101001
Calibration Expiration Date:	3/13/2020
Calibration $\gamma$ Factor:	0.998

Unit Under Test Previous Calibration	
Date	6/15/2018
$\gamma$ Factor:	0.999
Allowable Deviation ( $\pm 5\%$ ):	0.04995
Actual Deviation:	0.01
Result:	PASS

Calibration Data	Run 1	Run 2	Run 3
Standard DGM Initial Volume (L)	0.000	0.000	0.000
Standard DGM Final Volume (L)	146.758	221.981	165.496
Standard DGM Temperature ( $^{\circ}$ F)	75.0	76.0	77.0
Standard DGM Pressure (in H <sub>2</sub> O)	0.00	0.00	0.0
DGM Initial Volume (ft <sup>3</sup> )	0.000	0.000	0.000
DGM Final Volume (ft <sup>3</sup> )	5.283	8.006	5.965
DGM Temperature ( $^{\circ}$ F)	82.0	84.0	85.0
DGM Pressure (in H <sub>2</sub> O)	0.00	0.00	0.0
Time (min)	27.0	41.0	30.0
Net Volume for Standard DGM (ft <sup>3</sup> )	5.183	7.839	5.844
Net Volume for DGM (ft <sup>3</sup> )	5.283	8.006	5.965

Dry Gas Meter $\gamma$ Factor	0.992	0.992	0.992
$\gamma$ Factor Deviation From Average	0.992	0.992	0.992

Average Gas Meter  $\gamma$  Factor

0.992

Calculations:

- Deviation = |Average value for all runs - current run value|
- $\gamma = [V_{std} \times (\gamma_{std}) \times (P_{bar} + P_{std}/13.6) \times (T_{DGM} + 460)] / [V_{DGM} \times (T_{std} + 460) \times (P_{bar} + P_{DGM}/13.6)]$

Standard Reference Meter is calibrated to NIST traceable standards. Uncertainty of measurement is  $\pm 0.5\%$ .



# QUALITY CONTROL SERVICES

LABORATORY EQUIPMENT • SALES • SERVICE • CALIBRATION • REPAIRS  
2340 SE 11<sup>TH</sup> Ave. Portland, Oregon 97214 • Box 14831 Portland, Oregon 97293  
(503) 236-2712 • FAX (503) 235-2535 • www.qc-services.com



## Report of Calibration

Firm: Dirigo Laboratories  
Address: 11785 SE Hwy 212, Ste 305  
City/State/Zip: Clackamas, OR 97015

Test Completed: 03/21/17  
Submitted By: John Steiner  
Traceable Number: 20170468

Test Item: 200mg and 100mg Individual Weights  
Serial No.: Listed in Table

Manufacturer: Troemner

<u>Material</u>	<u>Assumed Density</u>	<u>Range</u>	<u>Tolerance Class</u>
Stainless Steel	7.95 g/cm <sup>3</sup>	200mg & 100mg	ASTM Class 1

### Method and Traceability

The procedure used for this calibration is NIST IR 6969 SOP 4 Double Substitution Weighing Design. Standards used for comparison are traceable to the National Institute of Standards and Technology (reports on file) and are part of a comprehensive measurement assurance program for ensuring continued accuracy and traceability within the level of uncertainty reported. The Traceable Number listed above is Traceable to National Standards through an unbroken chain of comparison each having stated uncertainties.

### Standards Used:

100g to 1mg Working Standards Were Calibrated: 03/03/17 Due: 03/31/18 Standards ID: 723318  
Mass Comparators Used: MET-05 Tested by: D. Thompson

**Conventional Mass:** “The conventional value of the result of weighing a body in air is equal to the mass of a standard, of conventionally chosen density, at a conventionally chosen temperature, which balances this body at this reference temperature in air of conventionally chosen density. International Recommendation 33 (OIML IR 33 1973, 1979). “Conventional Value of the Result of Weighing in Air” (Previously known as “Apparent Mass vs. 8.0g/cm<sup>3</sup>”).

**Uncertainty Statement:** The uncertainty conforms to the ISO Guide to the Expressions of Uncertainty in Measurement. Uncertainty as reported is based on a coverage factor k=2 for an approximate 95 percent level of uncertainty. Uncertainty components include the standard deviation of the process, the uncertainty of the standard used, an uncertainty component associated with the potential drift of the standard used, and the estimated uncertainty related to measuring and determining the air buoyancy effect.

Conventional Mass Values are listed on page 2 of this report.

page 1 of 2

Quality Control Services, Inc.  
Metrology Laboratory Manager  
E-mail [dthompson@qc-services.com](mailto:dthompson@qc-services.com)

Date: 03/21/17

Signature David S. Thompson

This document shall not be reproduced, except in full, without the written approval of Quality Control Services Mass Laboratory.

Member: National Conference of Standards Laboratories and Weights & Measures



# QUALITY CONTROL SERVICES

LABORATORY EQUIPMENT • SALES • SERVICE • CALIBRATION • REPAIRS  
2340 SE 11<sup>TH</sup> Ave. Portland, Oregon 97214 • Box 14831 Portland, Oregon 97293  
(503) 236-2712 • FAX (503) 235-2535 • www.qc-services.com



## Report of Calibration

Firm: Dirigo Laboratories  
Address: 11785 SE Hwy 212, Ste 305  
City/State/Zip: Clackamas, OR 97015

Test Completed: 03/21/17  
Submitted By: John Steiner  
Traceable Number: 20170468

Test Item: 200mg and 100mg Individual Weights  
Serial No.: Listed in Table

Manufacturer: Troemner

### Laboratory Environment at time of test

Temperature °C	Pressure mmHg	Humidity %RH
21.967	753.44	49.44

### Conventional Mass Value

Nominal Value	As Found grams	As Found Correction* (mg)	Uncertainty (mg)	Tolerance (mg)
200mg SN 1000101395	0.2000061	0.0061	0.0026	0.01
100mg SN 1000126267	0.1000046	0.0046	0.0028	0.01

\*Correction is the difference between the conventional mass value of a weight and its nominal value.

**Comments:** These weights were new from the manufacturer and were within ASTM Class 1 tolerances As Found. No adjustments or changes were made so As Found values should be considered to be As Left values.

Accredited by the American Association for Laboratory Accreditation (A2LA) under Calibration Laboratory Code 115953 and Certificate Number 1550.01. This laboratory meets the requirements of ISO/IEC 17025:2005 *General Requirements for the Competence of Testing and Calibration Laboratories*. This laboratory also meets the requirements of ANSI/NCSL Z540-1-1994 and any additional program requirements in the field of calibration.

page 2 of 2

Quality Control Services, Inc.  
Metrology Laboratory Manager  
E-mail [dthompson@qc-services.com](mailto:dthompson@qc-services.com)

Date: 03/21/17

Signature David S. Thompson



# QUALITY CONTROL SERVICES

LABORATORY EQUIPMENT • SALES • SERVICE • CALIBRATION • REPAIRS  
2340 SE 11<sup>TH</sup> Ave. Portland, Oregon 97214 • Box 14831 Portland, Oregon 97293  
(503) 236-2712 • FAX (503) 235-2535 • www.qc-services.com



## Report of Calibration

Firm: Dirigo Laboratories  
Address: 11785 SE Hwy 212, Ste 305  
City/State/Zip: Clackamas, OR 97015

Test Completed: 01/15/16  
Purchase Order: 1001  
Traceable Number: 20152489

Test Item: 20lb and 10lb Individual Grip Handle Weights  
Serial No.: Listed in Table

Manufacturer: Unknown

### Laboratory Environment at time of test

Temperature °C	Pressure mmHg	Humidity %RH
21.448	760.64	44.58

### Conventional Mass Value

Nominal Value	As Found pounds	As Found Correction* (mg)	Uncertainty (mg)	Tolerance (mg)
20lb #098	19.9995450	-206.4	6.4	910
10lb #097	10.0006510	295.3	5.1	450
10lb #051	10.0003421	155.2	5.1	450

\*Correction is the difference between the conventional mass value of a weight and its nominal value.

**Comments:** These weights were received in good condition and were within NIST Handbook 105-1 Class F tolerances As Found. No adjustments or changes were made so As Found values should be considered to be As Left values.

Accredited by the American Association for Laboratory Accreditation (A2LA) under Calibration Laboratory Code 115953 and Certificate Number 1550.01. This laboratory meets the requirements of ISO/IEC 17025:2005 *General Requirements for the Competence of Testing and Calibration Laboratories*. This laboratory also meets the requirements of ANSI/NCSL Z540-1-1994 and any additional program requirements in the field of calibration.

page 2 of 2

Quality Control Services, Inc.  
Metrology Laboratory Manager  
E-mail [dthompson@qc-services.com](mailto:dthompson@qc-services.com)

Date: 01/15/16

Signature David S. Thompson



# QUALITY CONTROL SERVICES

LABORATORY EQUIPMENT • SALES • SERVICE • CALIBRATION • REPAIRS  
2340 SE 11<sup>TH</sup> Ave. Portland, Oregon 97214 • Box 14831 Portland, Oregon 97293  
(503) 236-2712 • FAX (503) 235-2535 • www.qc-services.com



PFS Teco  
11785 SE Hwy 212 STE#305  
Clackamas, OR 97015

Report Number: DIRI0134307497181218

## A2LA ACCREDITED CERTIFICATE OF CALIBRATION WITH DATA

### INSTRUMENT INFORMATION

Item	Make	Model	Serial Number	Customer ID	Location
Balance	Sartorius	ENTRIS224-1S	34307497	#107	Lab
Units	Readability	SOP	Cal Date	Last Cal Date	Cal Due Date
g	0.0001	QC012	12/18/18	6/13/18	12/2019

### FUNCTIONAL CHECKS

ECCENTRICITY		LINEARITY		STANDARD DEVIATION			ENVIRONMENTAL CONDITIONS
Test Wt:	Tol:	Test Wt:	Tol:	Test Wt:	Tol:		
100	0.0003	50 x 4	0.0002	100	0.0001		<input type="checkbox"/> <input checked="" type="checkbox"/> <input type="checkbox"/>
<b>As-Found:</b>		<b>As-Found:</b>		1. 100.0001	5. 100.0002	9. 100.0001	Good Fair Poor
Pass: <input checked="" type="checkbox"/>	Fail: <input type="checkbox"/>	Pass: <input checked="" type="checkbox"/>	Fail: <input type="checkbox"/>	2. 100.0001	6. 100.0001	10. 100.0001	
<b>As-Left:</b>		<b>As-Left:</b>		3. 100.0001	7. 100.0001	<b>Result</b>	Temperature: 21.3°C
Pass: <input checked="" type="checkbox"/>	Fail: <input type="checkbox"/>	Pass: <input checked="" type="checkbox"/>	Fail: <input type="checkbox"/>	4. 100.0001	8. 100.0002	0.00004	

### A2LA ACCREDITED SECTION OF REPORT

Standard	As-Found	As-Left	Expanded Uncertainty
200	200.0002	200.0001	0.00014
100	100.0001	100.0001	0.00014
50	50.0003	50.0001	0.00014
20	20.0001	20.0001	0.00014
1	1.0001	1.0000	0.00014
0.1	0.1000	0.1000	0.00014

### CALIBRATION STANDARDS

Item	Make	Model	Serial Number	Cal Date	Cal Due Date	NIST ID
Weight Set	R.L./Troemner	10kg to 1mg	G782	1/3/18	1/2019	20172421

Permanent Information Concerning this Equipment:

12 month calibration cycle.

Comments/Info Concerning this Calibration:

12/18 - RH = 56%. Adjusted span.

Report prepared/reviewed by: ServiceTech X Date: 12/28/18

Technician: R. Kauble

Signature:

THIS CERTIFICATE SHALL NOT BE REPRODUCED WITHOUT THE APPROVAL OF QUALITY CONTROL SERVICES, INC.

The uncertainty is calculated according to the ISO Guide to the Expression of Uncertainty in Measurement and includes the uncertainty of standards used combined with the observed standard deviation and readability of the unit under test. The uncertainty is expanded with a k factor of 2 for an approximate 95% level of confidence. Instruments listed above were calibrated using standards traceable to the National Institute of Standards and Technology (NIST). Calibration data reflect results at the time and location of calibration. Calibration data should be reviewed to insure that the instrument is performing to its required accuracy. Calibrations comply with ISO/IEC 17025 and ANSI/Z540-1-1994 quality standards.



# CERTIFICATE OF CALIBRATION

<b>CUSTOMER:</b>	<b>PFS-TECO :</b> CLACKAMAS, OR	<b>CALIBRATION DATE:</b>	03/14/2019
<b>PO NUMBER:</b>	N/A	<b>CALIBRATION DUE:</b>	03/14/2020
<b>INST. MANUFACTURER:</b>	DWYER	<b>PROCEDURE:</b>	T.O.33K6-4-1769-1
<b>INST. DESCRIPTION:</b>	VELOMETER	<b>CALIBRATION FLUID:</b>	AIR @ 14.7 PSIA 70°F
<b>MODEL NUMBER:</b>	471	<b>RECEIVED CONDITION:</b>	WITHIN MFG. SPECS.
<b>SERIAL NUMBER:</b>	CP288559 (ID# 095)	<b>LEFT CONDITION:</b>	WITHIN MFG. SPECS.
<b>RATED UNCERTAINTY:</b>	SEE NOTES BELOW.	<b>AMBIENT CONDITIONS:</b>	762 mm HGA 43% RH 69°F
<b>UNCERTAINTY GIVEN:</b>	± .20% RD ; k=2	<b>CERTIFICATE FILE #:</b>	490265.2019
<b>NOTES:</b>	± 3% FS (0-500 / 0-1500) *** ± 4% F.S. (0-5000) ***± 5% F.S. (0-15000) *** ± 2 °F		
<b>NOTES CONT. :</b>	<b>Q.MANUAL IM 1.5 REV 2017.1 DATED 7-18-2017</b>		

UUT INDICATED FT/MIN	DM.STD. ACTUAL FT/MIN	UUT INDICATED DEG. F	DM STD. ACTUAL DEG. F
64	65	0 TO 200°F	0 TO 200°F
110	112	43.4	43.5
206	210	69.0	68.9
498	509	99.4	99.2
503	505		
1049	1058		
1497	1514		
509	513		
3419	3460		
4992	5068		
5136	5235		
13928	14232		

**STANDARDS USED:**

A220: 12" WIND TUNNEL 0 - 8000 FPM   CMC ± .203% RD   TRACE# 1520423238	DUE	05/23/2019
A24: HART SCIENTIFIC TEMP. STANDARD   ±.024 F   TRACE# 1520423238	DUE	03/07/2020

All instruments used in the performance of the shown calibration have traceability to the National Institute of Standards and Technology (NIST). The uncertainty ratio between the calibration standards (DM.STD.) used and the unit under test (UUT) is a minimum of 4:1, unless otherwise noted. Calibration has been performed per the shown procedure number, in accordance with ISO 10012:2003, ISO 17025:2005, ANSI/NCSSL-Z-540.3, and/or MIL-STD-45662A. Test methods: API2530-92 & ASME MFC-3M-1989.

**Dick Munns Company • 11133 Winners Circle • Los Alamitos, CA 90720**  
Phone (714) 827-1215 • Fax (714) 827-0823

This Calibration Certificate shall not be reproduced, except in full, without approval by DICK MUNNS COMPANY. The data shown applies only to the instrument being calibrated and under the stated conditions of calibration.

Date:

3/14/2019

Approved by:

Calibration Technician:

D.C.



# Model 1430 Microtector® Electronic Point Gage

## Installation and Operating Instructions



**Model 1430 Microtector® Portable Electronic Point Gage** combines modern, solid-state integrated circuit electronics with a time-proven point gage manometer to provide fast, accurate pressure measurements.

### SPECIFICATIONS AND FEATURES

- Accurate and repeatable to  $\pm .00025$  inches water column
- Pressure range: 0 - 2" w.c., positive, negative, or differential pressures
- Non-toxic and inexpensive gage fluid consists of distilled water mixed with a small amount of fluorescein green color concentrate
- Convenient, portable, lightweight and self-contained, the unit requires no external power connections and is operated by a 1.5 volt penlight cell
- A.C. detector current eliminates point plating, fouling and erosion
- Micrometers are manufactured in accordance with ASME B89.1.13-2001, and are traceable to a standard at the National Institute of Standards and Technology
- Three-point mounting, dual leveling adjustment, and circular level vial assure rapid setup
- Durablock® precision-machined acrylic gage body
- Sensitive 0 - 50 microamp D.C. meter acts as a detector and also indicates battery and probe condition
- Heavy 2" thick steel base plate provides steady mounting
- Top-quality glass epoxy circuit board and solid-state, integrated circuit electronics
- Electronic enclosure of tough, molded styrene acrylonitrile provides maximum protection to components yet allows easy access to battery compartment
- Rugged sheet steel cover and carrying case protects the entire unit when not in use
- Accessories included are (2) 3-foot lengths Tygon® tubing, (2) 1/8" pipe thread adapters and 3/4 oz. bottle of fluorescein green color concentrate with wetting agent

**Maximum pressure: 100 psig with optional pipe thread connections.**

Tygon® is a registered trademark of Saint-Gobain Corporation

**DWYER INSTRUMENTS, INC.**

P.O. BOX 373

MICHIGAN CITY, INDIANA 46361, U.S.A.

Phone: 219/879-8000

Fax: 219/872-9057

www.dwyer-inst.com

e-mail: info@dwyer-inst.com

# Verification of Standardization

of

## Tape Measure

by

Advanced Calibration Technologies

28111 S.E. Wally Road

Boring, OR 97009

1-800-259-5058



Customer: PFS Teco, Inc	Street: 11785 Southeast Highway 212 Suite 305
City: Clackamas State: OR	Zip: 97015 Location: In House
Machine Manufacturer: Dewalt	Model: 16' Tape Measure
Capacity: 0.000 - 192.000 inches 0.125 Divisions	Serial #: 090
Calibration Cycle: 12 Months	Lab ID#: #090
Previous Calibration Date: January 2019	Calibration Procedure: Ad-Tek SR
Equipment Used: Gauge Blocks S/N: ADGB002	Action Recommended:
If Other, Explain:	

### Verification Data

<u>Purpose:</u> This method provides instructions for checking the critical dimensions of the equipment.			
<u>Tolerance:</u> Equipment shall meet the dimensional tolerances specified in the applicable test method.			
<u>Procedure:</u> Verified using manufacturer's procedures.			
Actual Dimensions (inches)	Unit Under Test As Found (inches)	Unit Under Test As Left (inches)	Difference (inches)
0.0000	0.000	0.000	0.000
0.1250	0.050	0.050	-0.075
0.2500	0.250	0.250	0.000
0.5000	0.500	0.500	0.000
0.7500	0.750	0.750	0.000
1.0000	1.000	1.000	0.000
3.0000	3.000	3.000	0.000
5.0000	5.000	5.000	0.000
7.0000	7.000	7.000	0.000
9.0000	9.000	9.000	0.000
12.0000	12.000	12.000	0.000
The overall condition of the device as found:		Within Specification	
The overall condition of the device as left:		Within Specification	
The measurement of uncertainty (MU) was calculated to be:		0.00060	

File No: PFS-101666-0119D0120-AH-SR-090

Temperature: 72.1°F Humidity: 41.1%

The equipment used in the verification of this instrument has been calibrated and is NIST traceable.  
The uncertainty of calibration was estimated at the 95% confidence level, coverage factor (k=2).

Remarks: \_\_\_\_\_

This certificate of verification is issued as a statement of fact that on the date of verification the above instrument had an accuracy as indicated and was calibrated to meet the requirements of the manufacturer's specifications. This certificate should not be construed or regarded as a guarantee or warranty of any kind that the instrument will retain the same percentage of accuracy as determined on the date when the verification was performed and reported. Ad-Tek, Inc. hereby expressly disclaims any and all liability for damage or loss by all parties arising or resulting from deterioration, obsolescence, malfunction, subsequent calibration performed by another agency or substandard performance of said instrument.

This report and certificate of verification shall not be reproduced except in full, without the written approval of Ad-Tek, Inc.

Service Technician: Alisa Houser Date of Service: January 16, 2019

Technical Manager: Nicole Ostrowski Date Next Due: January 2020

We sincerely appreciate your business and thank you for selecting Advanced Calibration Technologies, Inc. for servicing your equipment.  
To reschedule, please call (800) 259-5058. Thank You.



# Verification of Standardization

## of Calipers

by  
Advanced Calibration Technologies  
28111 S.E. Wally Road  
Boring, OR 97009  
1-800-259-5058



Customer: PFS Teco, Inc	Street: 11785 Southeast Highway 212 Suite 305
City: Clackamas State: OR	Zip: 97015 Location: In House
Machine Manufacturer: General	Model: 6" Digital Caliper
Capacity: 0.0000 - 6.0000 inches 0.0005 Divisions	Serial #: 092
Calibration Cycle: 12 Months	Lab ID#: 092
Previous Calibration Date: January 2018	Calibration Procedure: Ad-Tek DC
Equipment Used: Gauge Blocks S/N: ADGB002	Action Recommended:
If Other, Explain:	

### Verification Data

<b>Purpose:</b> This method provides instructions for checking the critical dimensions of the inside diameter of the equipment.			
<b>Tolerance:</b> Equipment shall meet the dimensional tolerances specified by the manufacturer for the inside diameter.			
<b>Procedure:</b> Verified using the procedure to meet manufacturer's tolerance for inside diameter.			
Actual Dimensions (inches)	Unit Under Test As Found (inches)	Unit Under Test As Left (inches)	Difference (inches)
0.0000	0.0000	0.0000	0.0000
0.0500	0.0500	0.0500	0.0000
0.1000	0.1000	0.1000	0.0000
0.1010	0.1010	0.1010	0.0000
0.1050	0.1050	0.1050	0.0000
0.1100	0.1100	0.1100	0.0000
0.1500	0.1500	0.1500	0.0000
0.5000	0.5000	0.5000	0.0000
1.0000	1.0000	1.0000	0.0000
3.0000	2.9995	2.9995	-0.0005
5.0000	4.9990	4.9990	-0.0010
The overall condition of the device as found:		Within Specification	
The overall condition of the device as left:		Within Specification	
The measurement of uncertainty (MU) was calculated to be:		0.00062	

This certificate does not reflect measurements for inside jaws, step height, or depth.

File No: PFS-101666-0119D0120-AH-DC-092

Temperature: 68.2°F Humidity: 41.6%

The equipment used in the verification of this instrument has been calibrated and is NIST traceable.  
The uncertainty of calibration was estimated at the 95% confidence level, coverage factor (k=2).

Remarks: \_\_\_\_\_

This certificate of verification is issued as a statement of fact that on the date of verification the above instrument had an accuracy as indicated and was calibrated to meet the requirements of the manufacturer's specifications. This certificate should not be construed or regarded as a guarantee or warranty of any kind that the instrument will retain the same percentage of accuracy as determined on the date when the verification was performed and reported. Ad-Tek, Inc. hereby expressly disclaims any and all liability for damage or loss by all parties arising or resulting from deterioration, obsolescence, malfunction, subsequent calibration performed by another agency or substandard performance of said instrument.

This report and certificate of verification shall not be reproduced except in full, without the written approval of Ad-Tek, Inc.

Service Technician: Alisa Houser Date of Service: January 15, 2019

Technical Manager: Nicole Ostrowski Date Next Due: January 2020

We sincerely appreciate your business and thank you for selecting Advanced Calibration Technologies, Inc. for servicing your equipment.  
To reschedule, please call (800) 259-5058. Thank You.

# J-2000

owner's manual



**DELMHORST**<sup>®</sup>  
INSTRUMENT CO.

WHEN ACCURACY IS THE POINT.<sup>™</sup>



Calibration complies with ISO/IEC 17025, ANSI/NCSL Z540-1, and 9001



Cert. No.: 4198-9765787

Traceable® Certificate of Calibration for Hand Held Barometer

Customer :PFS TECO Suite 305 ,11785 SE Highway 212 ,Clackamas ,OR-97015 ,U.S.A.

Instrument Identification:

Model: 4198,

S/N: 80531676

Manufacturer: Control Company

Standards/Equipment:

Table with 4 columns: Description, Serial Number, Due Date, NIST Traceable Reference. Rows include Digital Barometer and Digital Thermometer.

Certificate Information:

Technician: 57

Procedure: CAL-32

Cal Date: 29 Aug 2018

Cal Due Date: 29 Aug 2019

Test Conditions: 62.73%RH 23.92°C 1018mBar

Calibration Data:

Table with 11 columns: Unit(s), Nominal, As Found, In Tol, Nominal, As Left, In Tol, Min, Max, ±U, TUR. Rows show calibration data for temperature and pressure.

This certificate indicates Traceability to standards provided by (NIST) National Institute of Standards and Technology and/or a National Standards Laboratory.

A Test Uncertainty Ratio of at least 4:1 is maintained unless otherwise stated and is calculated using the expanded measurement uncertainty. Uncertainty evaluation includes the instrument under test and is calculated in accordance with the ISO "Guide to the Expression of Uncertainty in Measurement : (GUM). The uncertainty represents an expanded uncertainty using a coverage factor k=2 to approximate a 95% confidence level. In tolerance conditions are based on test results falling within specified limits with no reduction by the uncertainty of the measurement. The results contained herein relate only to the item calibrated. This certificate shall not be reproduced except in full, without written approval of Control Company.

Nominal=Standard's Reading; As Left=Instrument's Reading; In Tol=In Tolerance; Min/Max=Acceptance Range; ± U=Expanded Measurement Uncertainty; TUR=Test Uncertainty Ratio; Accuracy=±(Max-Min)/2; Min=As Left Nominal(Rounded) - Tolerance; Max= As Left Nominal(Rounded) + Tolerance;

Nicol Rodriguez

Nicol Rodriguez, Quality Manager

Aaron Justice

Aaron Justice, Technical Manager

Note :

Maintaining Accuracy:

In our opinion once calibrated your Hand Held Barometer should maintain its accuracy. There is no exact way to determine how long calibration will be maintained. Hand Held Barometer change little, if any at all, but can be affected by aging, temperature, shock, and contamination.

Recalibration:

For factory calibration and re-certification traceable to National Institute of Standards and Technology contact Control Company.

CONTROL COMPANY 12554 Galveston RD Suite B230 Webster TX USA 77598
Phone 281 482-1714 Fax 281 482-9448 sales@control3.com www.control3.com

Control Company is an ISO/IEC 17025:2005 Calibration Laboratory Accredited by (A2LA) American Association for Laboratory Accreditation, Certificate No. 1750.01.
Control Company is ISO 9001:2008 Quality Certified by DNV GL, Certificate No. CERT-01805-2006-AQ-HOU-RvA.
International Laboratory Accreditation Cooperation (ILAC) - Multilateral Recognition Arrangement (MRA).

### CERTIFICATE OF ANALYSIS

#### Grade of Product: CERTIFIED STANDARD-SPEC

Part Number:	X04NI62C15A0002	Reference Number:	16-401222766-1
Cylinder Number:	CC50101	Cylinder Volume:	144.0 CF
Laboratory:	101 - Portland (SAP) - OR	Cylinder Pressure:	2016 PSIG
Analysis Date:	Jun 19, 2018	Valve Outlet:	590
Lot Number:	16-401222766-1		

Expiration Date: Jun 19, 2026

Product composition verified by direct comparison to calibration standards traceable to N.I.S.T. weights and/or N.I.S.T. Gas Mixture reference materials.

#### ANALYTICAL RESULTS

Component	Req Conc	Actual Concentration (Mole %)	Analytical Uncertainty
CARBON MONOXIDE	4.000 %	4.048 %	+/- 2%
CARBON DIOXIDE	16.00 %	15.53 %	+/- 2%
OXYGEN	18.00 %	18.09 %	+/- 2%
NITROGEN	Balance		



  
Approved for Release

**CERTIFICATE OF BATCH ANALYSIS**  
**Grade of Product: ULTRA HIGH PURITY-PURE**

Part Number: NI UHP200BA  
Cylinder Analyzed: BSG-000543  
Laboratory: 101 - Portland (SAP) - OR  
Analysis Date: Jun 29, 2017  
Lot Number: 16-400945060-1  
Reference Number: 16-400945060-1  
Cylinder Volume: 230.0 CF  
Cylinder Pressure: 2200 PSIG  
Valve Outlet: 580

**ANALYTICAL RESULTS**

Component	Requested Purity	Certified Concentration
NITROGEN	99.999 %	99.999 %
CO + CO2	< 1 PPM	0.10 PPM
Moisture	< 1 PPM	0.877 PPM
Oxygen	< 1 PPM	0.24 PPM
THC	< 0.5 PPM	0.133 PPM

**Cylinders in Batch:**

AH18144, BSG-000543, BSG-001247, N399365, SG33414A, T653439, W435461

Impurities verified against analytical standards traceable to NIST by weight and/or analysis.

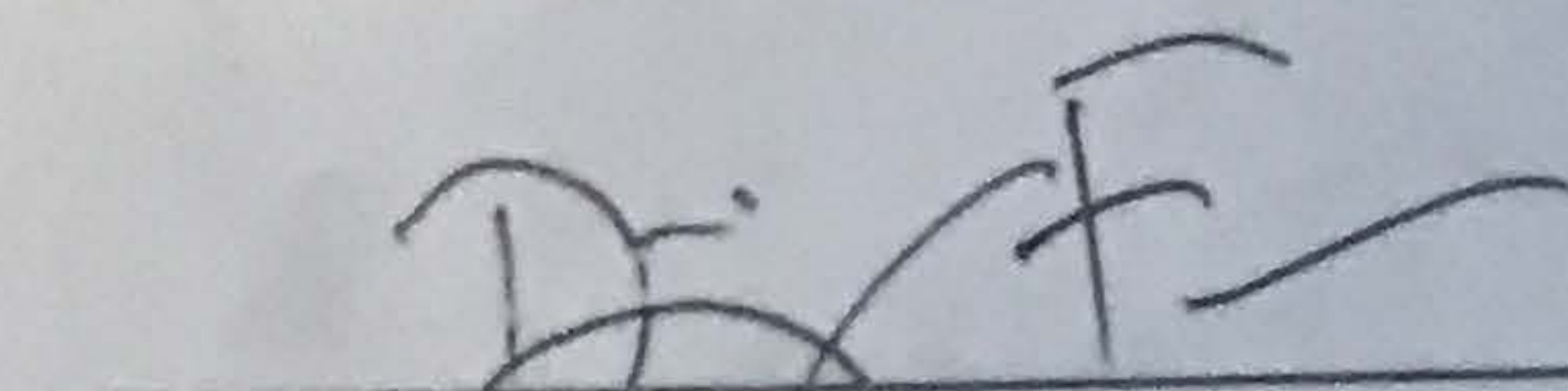
  
Approved for Release



# QUALITY CONTROL SERVICES

LABORATORY EQUIPMENT • SALES • SERVICE • CALIBRATION • REPAIRS  
 2340 SE 11<sup>TH</sup> Ave. Portland, Oregon 97214 • Box 14831 Portland, Oregon 97293  
 (503) 236-2712 • FAX (503) 235-2535 • www.qc-services.com

Nelke Consulting LLC  
 30522 SE Leavenworth Ct.  
 Eagle Creek, OR 97022

Report Number: NELK0116-1400TT029190327

## CERTIFICATE OF CALIBRATION WITH DATA

### INSTRUMENT INFORMATION

Item	Make	Model	Serial Number	Customer ID	Location
Scale	United	1000 lb	16-1400TT029	N/A	Lab
Units	Readability	SOP	Cal Date	Last Cal Date	Cal Due Date
lbs	0.1	QC033	3/27/19	4/18/18	3/2020

### FUNCTIONAL CHECKS

SHIFT TEST		LINEARITY		REPEATABILITY	
Test Wt:	Tol:	Test Wt:	Tol:	Test Wt:	Tol:
250	0.4	HB44	HB44	200	0.2
As-Found:		As-Found:		As-Found:	
Pass: <input checked="" type="checkbox"/>	Fail: <input type="checkbox"/>	Pass: <input checked="" type="checkbox"/>	Fail: <input type="checkbox"/>	Pass: <input checked="" type="checkbox"/>	Fail: <input type="checkbox"/>
As-Left:		As-Left:		As-Left:	
Pass: <input checked="" type="checkbox"/>	Fail: <input type="checkbox"/>	Pass: <input checked="" type="checkbox"/>	Fail: <input type="checkbox"/>	Pass: <input checked="" type="checkbox"/>	Fail: <input type="checkbox"/>

### CALIBRATION DATA

Standard	As-Found	As-Left
1000	1000.5	1000.5
700	700.5	700.5
500	500.4	500.4
200	200.0	200.0
100	100.1	100.1
50	50.0	50.0

### CALIBRATION STANDARDS

Item	Make	Model	Serial Number	Cal Date	Cal Due Date	NIST ID
Avoirdupois Cast W	Rice Lake	25 and 50lb	PWO990-CA	11/24/17	11/2019	20172265

#### Permanent Information Concerning this Equipment:

There is no adjustment procedure available for this scale.  
 Customer Range of use 0-200lbs.

#### Comments/Info Concerning this Calibration:

Technician: D.Oudeans

Signature: *D. Oudeans*

THIS CERTIFICATE SHALL NOT BE REPRODUCED, EXCEPT IN FULL, WITHOUT THE APPROVAL OF QUALITY CONTROL SERVICES, INC.

Instruments listed above were calibrated using standards traceable to the National Institute of Standards and Technology (NIST). Calibration data reflect results at the location of calibration. Calibration data should be reviewed to insure that the instrument is performing to its required accuracy.



# QUALITY CONTROL SERVICES

LABORATORY EQUIPMENT • SALES • SERVICE • CALIBRATION • REPAIRS  
 2340 SE 11<sup>TH</sup> Ave. Portland, Oregon 97214 • Box 14831 Portland, Oregon 97293  
 (503) 236-2712 • FAX (503) 235-2535 • www.qc-services.com

Nelke Consulting LLC  
 30522 SE Leavenworth Ct.  
 Eagle Creek, OR 97022

Report Number: NELK0116-1400TT029190327

## CERTIFICATE OF CALIBRATION WITH DATA

### INSTRUMENT INFORMATION

Item	Make	Model	Serial Number	Customer ID	Location
Scale	United	1000 lb	16-1400TT029	N/A	Lab
Units	Readability	SOP	Cal Date	Last Cal Date	Cal Due Date
lbs	0.1	QC033	3/27/19	4/18/18	3/2020

### FUNCTIONAL CHECKS

SHIFT TEST		LINEARITY		REPEATABILITY	
Test Wt:	Tol:	Test Wt:	Tol:	Test Wt:	Tol:
250	0.4	HB44	HB44	200	0.2
As-Found:		As-Found:		As-Found:	
Pass: <input checked="" type="checkbox"/>	Fail: <input type="checkbox"/>	Pass: <input checked="" type="checkbox"/>	Fail: <input type="checkbox"/>	Pass: <input checked="" type="checkbox"/>	Fail: <input type="checkbox"/>
As-Left:		As-Left:		As-Left:	
Pass: <input checked="" type="checkbox"/>	Fail: <input type="checkbox"/>	Pass: <input checked="" type="checkbox"/>	Fail: <input type="checkbox"/>	Pass: <input checked="" type="checkbox"/>	Fail: <input type="checkbox"/>

### CALIBRATION DATA

Standard	As-Found	As-Left
1000	1000.5	1000.5
700	700.5	700.5
500	500.4	500.4
200	200.0	200.0
100	100.1	100.1
50	50.0	50.0

### CALIBRATION STANDARDS

Item	Make	Model	Serial Number	Cal Date	Cal Due Date	NIST ID
Avoirdupois Cast W	Rice Lake	25 and 50lb	PWO990-CA	11/24/17	11/2019	20172265

#### Permanent Information Concerning this Equipment:

There is no adjustment procedure available for this scale.  
 Customer Range of use 0-200lbs.

#### Comments/Info Concerning this Calibration:

Signature: D. Oudeans

*D. Oudeans*

THIS CERTIFICATE SHALL NOT BE REPRODUCED, EXCEPT IN FULL, WITHOUT THE APPROVAL OF QUALITY CONTROL SERVICES, INC.

Instruments listed above were calibrated using standards traceable to the National Institute of Standards and Technology (NIST). Calibration data reflect results at the time and location of calibration. Calibration data should be reviewed to insure that the instrument is performing to its required accuracy.