

# User Manual

Rev. I

# Warnings



- For safety operation of the weighing indicator, please follow the following warning/safety instructions:
  - Calibration inspection and maintenance of the indicator are prohibited by non-professional staff
  - Please ensure that the indicator has good ground
  - The indicator is a static and sensitive equipment; Please cut off power during electrical connections; Touching the internal components by hand is prohibited; Please take anti-static prevention measures



# User Manual / Table of Contents

<b>Getting Started</b> .....	<b>4</b>
Overview.....	4
Technical Parameters.....	4
Indicator Drawing .....	5
Battery .....	6
Installation.....	6
Calibration and Parameter Settings .....	10
<b>Using Indicator</b> .....	<b>16</b>
Basic Weighing .....	16
Power On/Off.....	17
Zero .....	17
Tare .....	18
Changing Units .....	18
Hold .....	18
Print.....	18
Counting Function .....	19
Accumulation Function.....	19
RS232 Output Format .....	20
<b>More Info</b> .....	<b>23</b>
Troubleshooting .....	23
Technical Support.....	24

## Overview

Thank you for using AWI's LP7510 series indicator for your important application. The L7510 series weighing indicator can be used for many type of scales such as bench and floor scales. The basic functions are as follows:

- Hold function
- Print
- kg/lb unit conversion
- Count/Total
- Gross/Tare/Zero
- Overload reminder

Options can also be requested to include the following:

- RS232/RS485 serial interface or second display
- I/O
- 4-20mA outputs

## Technical Parameters

- Accuracy class: 6000 e
- Resolution:
  - Display: 30,000
  - ADC: 2,000,000
- Zero stability error:  $TK_0 < 0.1 \mu\text{V//K}$
- Span stability error:  $TK_{\text{spn}} < \pm 6 \text{ ppm//K}$
- Sensitivity (internal):  $0.3 \mu\text{V /d}$
- Input voltage: -30 to +30mV DC
- Excitation circuit: 5 VDC, 4 wire connection, 6 load cell of 350ohm maximum
- AC power: AC 100-250V (use only the 9V adapter supplied with the indicator)
- Operation temperature:  $-10 \text{ }^\circ\text{C} \sim +40 \text{ }^\circ\text{C}$
- Operation humidity:  $\leq 90\% \text{RH}$
- Storage temperature:  $-40 \text{ }^\circ\text{C} \sim +70 \text{ }^\circ\text{C}$

# Indicator Drawing

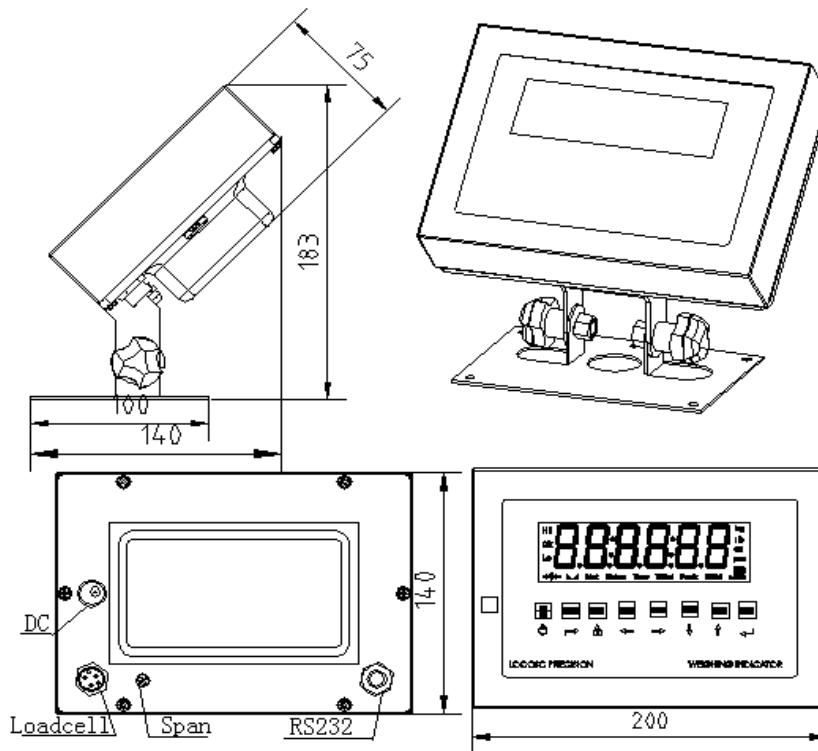
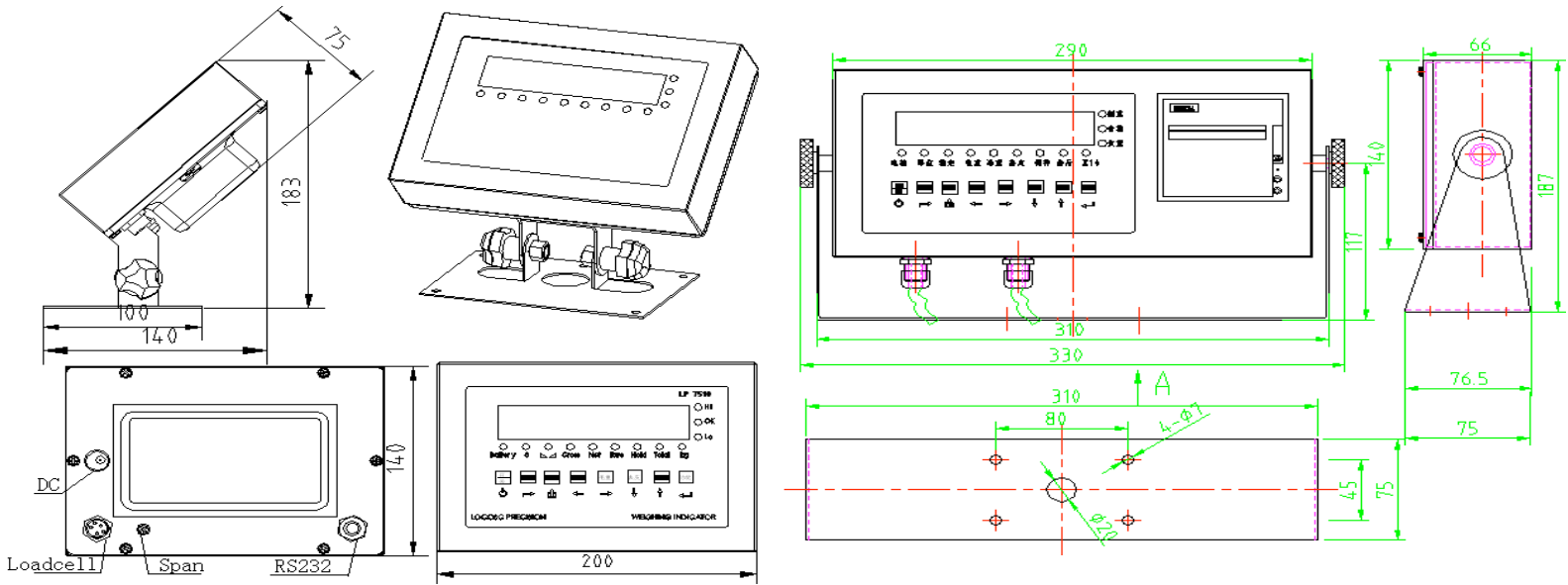

## Battery

- Charge the internal battery (option) fully before first time use
- When “battery” light is on, it means the battery is low and needs recharging
- During charging, the battery light turns yellow
- When the battery light turns green, it means the battery is fully charged
- Remove the battery when not in use for a long period of time
- To keep the battery in best condition, fully discharge battery every month by leaving the indicator on until indicator powers off

## Installation

- The indicator can connect with 6 load cell of 350ohm maximum with 4 wire or 6 wire load cell. There are two connection methods between the load cell and the indicator:
  - Quick disconnect

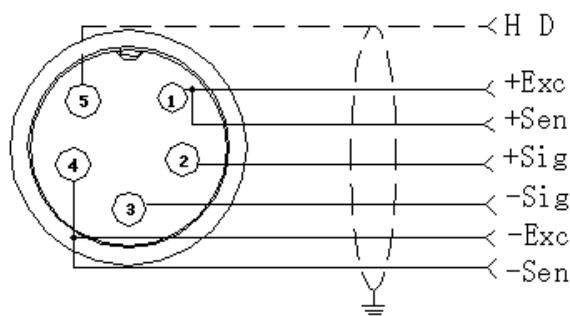

- Terminal trip connection (inner connection)
  - The excitation voltage for the load cell is 5VDC; largest output current = 120mA; maximum connect 6 350ohm load cell
  - Load cell (or the signal cable for the junction box) is connected with 5 pin terminal block (J5) on the circuit board of the weighing indicator
  - Open the back cover of the weighing indicator, and insert signal cable to the terminal block (J5); Make sure the screw is fixed tightly

# User Manual / Getting Started



-EXC -IN HD +IN +EXC

- +EXC = Positive excitation voltage to load cell
- +IN = Positive output signal from load cell
- HD = Shielded wire
- IN = Negative output signal from load cell
- EXC = Negative excitation voltage to load cell

- RS232: DB9 Pin or 3 Pin



DB9 joint	Definition	Function
2	TXD	Sending data
3	RXD	Receiving data
5	GND	Ground interface

Note: if RS485, The connection pin is 2 and 5 pin.

## 3 Pin definition

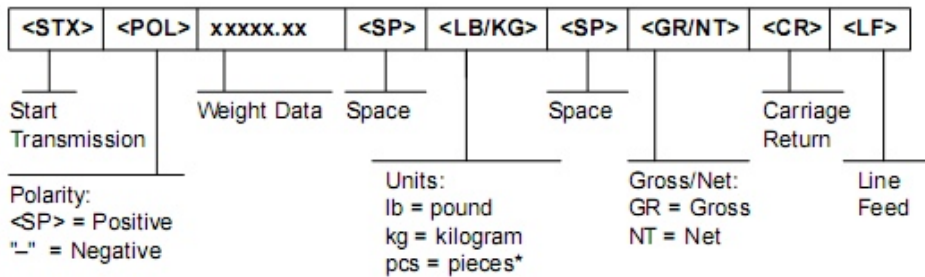

## User Manual / Getting Started

- 4-20mA output
  - Resolution: 1/1000
  - Outside Load: 100-350ohms
  - Inside connection: load input port connect with “I” of J2, ground port connect with “GND” of J2
  - Outside connection: load input port connect with pin 1 of DB9, ground port connect with pin 6 of DB9
  - To test the connection, connect a 250ohm load; Adjust the multimeter to the current stalls; To test the output current, connect the loading port to the red lead of the multimeter and the GND to the black lead of the multimeter
  - Calibration:
    - Press PRINT and TOTAL to go into configuration mode
    - Go to C32 and change out to out-20
  
- Relay output signal function
  - The indicator can output 4 signals, which when connected to outside equipment, can perform automatic control function and upper/lower limit alarm function. Goto setting C33 as follows:

	Output port	Port definition	Function
C33=0	Out1	Close output function	No output signal
	Out2	Close output function	No output signal
	Out3	Close output function	No output signal
	Out4	Close output function	No output signal
C33=1	Out1	Open overload control function	Output overload control signal
	Out2	Open compliance control function	Output compliance control signal
	Out3	Open under-load control function	Output under-load control signal
	Out4	Open stable control function	Output stable control signal
C33=2	Out1	Weight>=C13 instant connection	Feeding control signal
	Out2	Weight<=C14 instant connection	Feeding control signal
	Out3	OUT1、OUT2 close	Output alarm signal, connect with buzzer
	Out4	Weight<=C14 constant connection Weight>=C13 disconnect	Feeding start and stop
C33=3	Preserved, no function.		



## User Manual / Getting Started

- Examples:
  - Check weigh application:
    - Connect indicator with yellow, green and red lights.
      - Yellow light on when overload
      - Green light on when ok
      - Red light on when under-load
    - Connect with buzzer
  - Feeding control application
    - For hopper scales
      - Target between 50 to 500kg
      - I/O card can perform open and close feeding valve
  - Setting C13=500kg, C14=50kg
    - C13=upper limit -> close feeding valve
    - C14=lower limit -> open feeding valve
    - Indicator output signal will control the ON/OFF switch of the external equipment or machine
      - OUT2 ON, OUT1 OFF, OUT3 connect to buzzer, alarm reminder when start and stop
  - When weight over 500kg, OUT1 and OUT3 give instant connection and break off; OUT4 breaks off; when weight is under 50kg, OUT2 and OUT3 provide instant connection and break off; OUT4 constantly connected.

DB9 pin	definition	port
1 pin	1 <sup>st</sup> output signal pin	Out1
2 pin	1 <sup>st</sup> output signal pin	Out1
3 pin	2 <sup>nd</sup> output signal pin	Out2
4 pin	2 <sup>nd</sup> output signal pin	Out2
5 pin	3 <sup>rd</sup> output signal pin	Out3
6 pin	3 <sup>rd</sup> output signal pin	Out3
7 pin	4 <sup>th</sup> output signal pin	Out4
8 pin	4 <sup>th</sup> output signal pin	Out4

## Calibration and Parameter Settings

- To enter calibration/parameter settings
  - Press and hold the HOLD and PRINT key at the same time (OP-900)
    - For OP-901, press ON/OFF and SET at the same time
  - Navigate through the settings as shown in the following tables by using the arrow and return keys (labeled below the indicator keys)
  - Press the TOTAL key (OP-900) to save and exit settings at any time
    - Press ON/OFF key (do not hold) for OP-901

The following table shows the steps to properly calibrate the indicator in the calibration menu:

Step	Method of operation	Display	Remark
1		[C01 ]	After you enter calibration mode, it display [C01 ]
2	press ←	[C01 1]	Weight unit option: 1=kg 2=lb
3	press ← press ← press ↑ or ↓	[C02 ] [C02 0] [C02 2]	Set decimal digits option: 0/1/2/3/4 Select decimal digit example: two decimal point: [C02 2]
4	press ← press ← press ↑ or ↓	[C03 ] [C03 1] [C03 5]	Set graduation option: 1/2/5/10/20/50 Select required graduation example: graduation 5: [C03 5]
5	press ← press ← press ↑ or ↓/←	[C04 ] [0100.00] [0100.00]	Max capacity example: max weighing 100kg: [0100.00]
6	press ← press ← press ↑ press ←	[C05 ] [C05 0] [C05 1] [CAL 9] ◦ ◦ ◦ ◦ ◦ ◦ [0000.00]	Zero calibration Option 0=no need zero calibration 1=need zero calibration calibration zero please choose 1 and ensure scale is empty and “stable” light is on Ensure zero calibration, countdown. Till show[0.00](example for two decimal point)◦

# User Manual / Getting Started

7	<p>press ←</p> <p>press ←</p> <p>press ↑ or ↓</p> <p>press ←</p> <p>press ↑ or ↓</p> <p>press ←</p>	<p>[C06 ]</p> <p>[C06 0]</p> <p>[C06 1]</p> <p>[SPAN ]</p> <p>[0100.00]</p> <p>[0080.00]</p> <p>[CAL 9]</p> <p>.....</p> <p>[0080.00]</p> <p>[CAL End]</p>	<p>calibration option: 0=No need calibration 1= need calibration Load weights on scales according to max. capacity. Suggest close to the max capacity, at least 10% of max. capacity.</p> <p>For example: the weights is 80kg As bellows: Input the 0080.00, count down , then indicator shows 0080.00 , calibration is over. If you want to set application function parameter. Press "PRINT" if you want to exit press "TOTAL"</p>
8	<p>press ←</p> <p>press ←</p> <p>press ↑ or ↓</p>	<p>[C07 ]</p> <p>[07 0]</p> <p>[07 1]</p>	<p>Default parameters setting option:0=non-restore default parameters 1=restore default parameters Note: after the above parameters setting finish, please do not set default parameters to avoid the original setting parameters is lost.</p>

## User Manual / Getting Started

The following table shows the other parameter settings in the same calibration menu as above:

Function	Setting Item	parameters setting and instruction
warning tone	<b>C08</b> warning tone	Options: 0 = close warning tone 1 = open warning tone
Automatic power off	<b>C09</b> Automatic power off	option: 0=close auto power off 10= power off automatically if no change within 10 minute. 30= power off automatically if no change within 30 minute. 60= power off automatically if no change within 60 minute.
Power saving setting	<b>C10</b> Power saving setting	LED Version: option: 0= close power saving setting 3= close display if no change within 3min. 5= close display if no change within 5 min. LCD Version: 0=Close he backlight 1= backlight when the weight change or press the keyboard 2=constant backlight
Hold function	<b>C11</b> Hold mode	option: 0=close hold function 1=Peak hold /2=Data Hold Instruction: Peak-hold: it shows the max. data, mainly application for materials testing, such as tension and pulling force. Date-hold: it shows current weight value. Mainly application for animal weighing.
Kg/lb conversion	<b>C12</b> Kg/lb conversion	C12=0 stop kg/lb conversion C12=1 kg/lb conversion is ok
Upper/lower limit alarm	<b>C13</b> Upper limit alarm value	You can set it within the max. capacity limit
	<b>C14</b> Lower limit alarm value	
Inner Code display	<b>C15</b> Check inner code	Enter C15 to check the inner code

# User Manual / Getting Started

Date and time	<b>C16</b> Date	Enter C16, you can set the date, from left to right: year/month/day
	<b>C17</b> Time	Enter C17, you can set the time from left to right: hour/min./sec.
Communication setting	<b>C18</b> Serial interface data output method	option: 0= Close serial interface data output 1=Continuous sending, connect big display 2=Print method, connect printer. 3=Command request method , connect computer. 4=PC continues sending format, connect computer. 5=PC/ big display continuous sending format.
	<b>C19</b> Baud rate	option: 0=1200/1=2400/2=4800/3=9600
Zero range	<b>C20</b> Manually zero range	Option: 0= close manually zero setting 1=±1% max capacity 2=±2% max capacity 4=±4% max capacity 10=±10% max capacity 20=±20% max capacity 100=±100% max capacity
	<b>C21</b> Initial zero range	option: 0= no initial zero setting 1=±1% max capacity 2=±1% max capacity 5=±1% max capacity 10=±1% max capacity 20=±1% max capacity
Zero tracking	<b>C22</b> Automatically zero tracking range	Options: 0= close zero tracking 0.5=±0.5d 1.0=±1.0d 2.0=±2.0d 3.0=±3.0d 4.0=±4.0d 5.0=±5.0d  Note: 1. d = division 2. the zero tracking range can not bigger than manual zero range.
	<b>C23</b> Automatically zero tracking time	Options: 0= close zero tracking time 1= 1 second 2= 2 seconds 3= 3 seconds

# User Manual / Getting Started



Overload range	<b>C24</b> Overload range	option: 00= close overload range 01d~99d remark: d =division
Negative display	<b>C25</b> Negative display range	Option: 0=-9d 10=10% max. capacity 20=20% max. capacity 50=50% max. capacity 100=100% max. capacity
Standstill time	<b>C26</b> Standstill time	Option: 0= quick 1= medium 2= slow
	<b>C27</b> Standstill range	Option: 1= 1d 2=2d 5=5d 10=10d D= division
Digital filter	<b>C28</b> Dynamic filter Instruction: Dynamic filter is collecting the data filter before loaded weight stable. When loaded weight easily shaking (for example animal) , you can set this filter to make weight display more stable	option: 0= close dynamic filter 1=1 digital filter strength 2=2 digital filter strength 3=3 digital filter strength 4=4 digital filter strength 5=5 digital filter strength 6=6 digital filter strength Note: Pls setting dynamic filter strength carefully, the No. is bigger, more stable. if the loaded weight shake not too much. The setting is less than 3
	<b>C29</b> Noise filter	option: 0=close noise filter 1=1 digital filter strength 2=2 digital filter strength 3=3 digital filter strength
	<b>C30</b> Print time and date	C30=0 yy.mm.dd C30=1 mm.dd.yy C30=2 dd.mm.yy C30=3 yy.mm.dd
Analog output setting	C31 output type	C31=0 0~5Voutput C31=1 4~20mA output

## User Manual / Getting Started









4~20mA current calibrate	C32 calibrate current	Refer to 2.5
Relay output setting	C33 Relay output	C33=0 close relay output C33=1 Open relay output function 1 C3=2 Open relay output function2 C33=3 Preserved menu
Muti communication add.	C34 Communication add.	C34= 0~99 Add. Code
Wireless communication	C35	C35=0~99 signal
Gravity of calibration location	C36	C36=9.7000~9.9999
Gravity of destination	C37	C37=9.7000~9.9999
Version No.	C38	
Preserved menu	C39	

## Basic Weighing

After the scale has been properly calibrated, the scale is now ready for use. Here are the available keys as shown in the following overlays:

LED	instruction
	Weighing data
<b>kg</b>	kg
<b>lb</b>	lb
<b>Hold</b>	Data hold
<b>Gross</b>	Gross weight
<b>Net</b>	Net weight
<b>Tare</b>	tare
	The weighing data is stable
	Weight is zero
<b>Hi</b>	Overload
<b>OK</b>	ok
<b>Lo</b>	Underload
.	Decimal
<b>PCS</b>	Show the counting status.
<b>TOTAL</b>	Go to accumulation mode



keys	Key name	Key function
	Print	1.work with “ZERO” TARE” “ON/OFF” key to perform many functions. 2.Print
	Zero	Zero the weight within tolerance
	Tare	At G.W mode, get the tare weight. At N.W mode, clear the tare, get the G.W
	Gross weight	At N.W mode, check the G.W, after 3 seconds back to N.W automatically
	Counting	Counting operation
	Kg/lb convert	Covert between kg and lb
	Accumulation	1. Accumulation 2. work together with “ Print” to perform The accumulation function and check the accumulation result
	Power on/off	Press 2 seconds to power on or power off

## Power On/Off

- Press the ON/OFF key for about 2 seconds to power on/off the indicator. After self inspection, the indicator will go into weighing mode.

## Zero

- When the indicator is powered on, if the weight on the scale is within the initial zero tolerance, indicator will show zero automatically. This tolerance can be set in configuration C20 and C21.
- You can manually zero the indicator by pressing the Zero key.

### Tare

- When the indicator is in gross mode (Gross status light on), pressing the Tare key will tare the current weight. The indicator will then go into Net weight mode (Net status light on).
- When the indicator is already in net mode (Net status light on), pressing the Tare key will clear the tare weight and go back to gross mode (Gross status light on).

### Changing Units

- Press the kg/lb key to change between the following units:
  - kg (Status light kg on)
  - lb (Status light lb on)

### Hold

- Set configuration setting C11 to configure different hold functions

### Print

- Press the Print key to print to printer connected to RS232. Please remember to configure parameter settings C18 and C30.

## Counting Function

To perform counting function , follow the procedure below:

1. At weighing mode, load the weight to count and press the Count key. Indicator will show "PCS 0". Use the up and down arrow key to change the quantity that represents the load weight. Press the return (Print) key to confirm.
2. Press Count key to return to weighing mode.
3. Repeat the above steps for counting of different goods.

## Accumulation Function

1. After the weight is at zero mode (zero light on), load weight and wait for the stable light to turn on.
2. Press Total key and the Total light should turn on.
3. The indicator will display "n 001" and then the loaded weight.
4. Unload the weight, and load the 2nd weight until stable light on.
5. Press the Total key and the indicator will display "n 002" and then the loaded weight.
6. Repeat steps 4 and 5 to continue to accumulate (max 999 times).
7. After accumulation is finished, press the Total and ON/OFF key at the same time. The display will show the number of accumulation ("n \*\*\*\*") (first 4 digits) and then the total weight (last 4 digits).
8. After the indicator shows all 8 digits, press and hold Total key and the indicator will show "clr n".
9. Press the up or down key to change from "clr n" (don't clear total) and "clr y" (clear total). Press the Print key to accept and exit accumulation mode.

# RS232 Output Format

Big Display Continuous Output Format (CI8 = 1)

Output continuous format																	
S T X	S W A	S W B	S W C	X	X	X	X	X	X	X	X	X	X	X	X	C R	C K S
1	2		3				4				5	6					

State A			
Bits0,1,2			
0	1	2	Decimal point position
1	0	0	XXXXXX0
0	1	0	XXXXXXX
1	1	0	XXXXX. X
0	0	1	XXXX. XX
1	0	1	XXX. XXX
Bits3,4			Division
0	1		X1
1	0		X2

State B	
BitsS	function
Bits0	gross=0, net=1
Bits1	Symbol: positive =0,negative =1
Bits2	Overload(or under zero)=1
Bits3	dynamic=1
Bits4	unit: lb=0, kg=1
Bits5	Constant 1
Bits6	Constant 0

State C			
Bit2	Bit1	Bit0	unit
0	0	0	Kg or lb
0	0	1	g
0	1	0	t
Bit 3			printing=1
Bit 4			Extend display=1
Bit 5			Constant 1
Bit 6			Constant 0

## Computer Continuous Output Format (CI8 = 2)

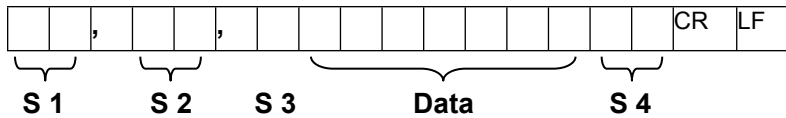

- S1: weight status, ST= standstill, US= not standstill, OL= overload
- S2: weight mode, GS=gross mode, NT=net mode
- S3: weight of positive and negative, "+" or "-"
- S4: "kg" or "lb"
- Data: weight value, including decimal point
- CR: carriage return
- LF: line feed

## Serial Interface Command Mode (CI8 = 3)

- In this mode, indicator can receive ASCII commands listed below:

Command	NAME	Function
T	TARE	Save and clear tare
Z	ZERO	Zero gross weight
P	PRINT	Print the weight
R	G.W/N.W	Read gross weight or net weight
C	Kg/lb	Kg/lb conversion
G	G.W	Check gross weight at net weight mode

- The R command will trigger the indicator to output the following data format:

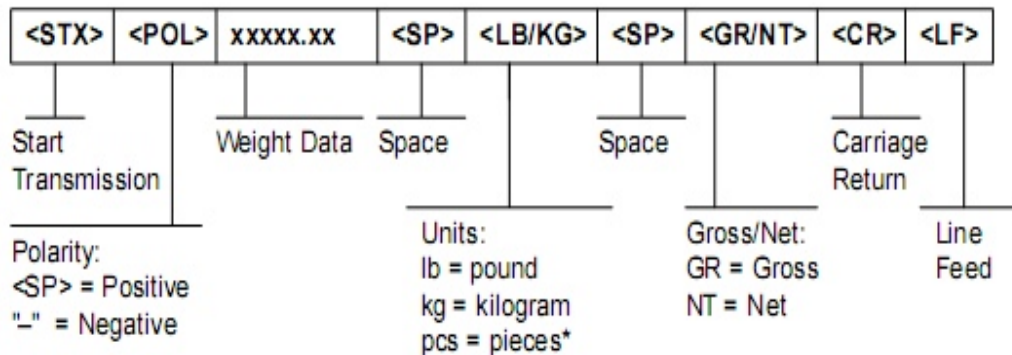

# User Manual / Using Scale

## Print Format (C18 = 4)

ID.NO. 004 (Serial No.)  
Date: XX.XX.XX (yy.mm.dd)  
Time: XX.XX.XX (hh.mm.ss)  
GROSS 8.88kg (gross weight)  
TARE 2.88kg (tare)  
NET 6.00kg (net weight)

## PC or Big Display Continuous Sending Format (C18 = 5)

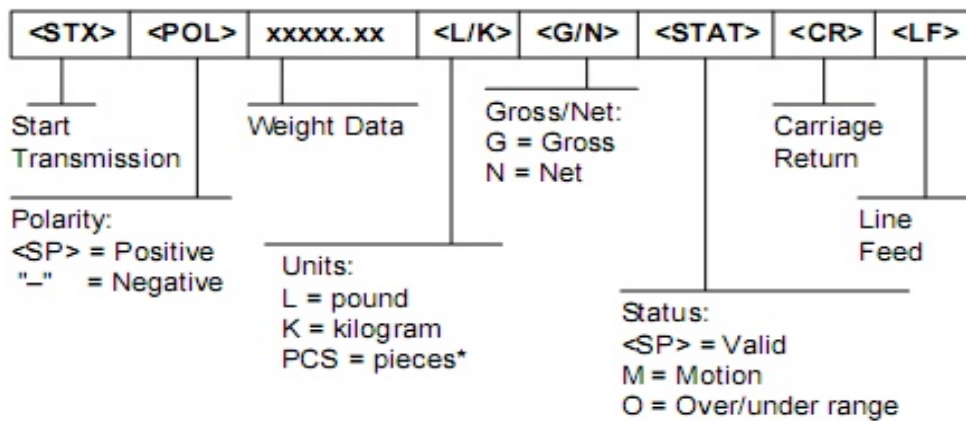

## Troubleshooting

Q:What are the different error codes?

A:The following table shows the error codes and explanations:

ERROR	REASON	SOLUTION
UUUUUU	1. Overload 2. wrong connection with load cell 3. load cell has quality problem.	1. reduce the weight 2. check load cell connection 3. inspection load cell. Check the input and output
nnnnnnn	1. calibration is no good 2. wrong connection 3. load cell has quality problem	1. check scale is resisted or not, foot is kept level or not. 2. check load cell connection. 3. checking load cell: check input and output resistance to judge it is good or not.
ERR1	During calibration, not input the weights or the weight is overload	Input the correct weights
ERR2	During calibration , the weights is below than Min. required weights	The calibration weights Minimum is 10% of Max. cap. Recommend 60%-80% of Max. Cap.
ERR3	During calibration, the input signal is negative	1. check the connection is correct 2. check load cell is no problem 3. recalibration if still wrong change the PCB
ERR4	During calibration, the signal is unstable	After the platform is stable, start calibration
ERR5		Change PCB

Q: The scale does not turn on.

A: Make sure the power cord is plugged in, and that there is power. One easy way to test this is by connecting another appliance to the same outlet and see if it's operational.

Q: The reading goes negative when a load is applied.

A: Try interchanging the Sig+ and Sig- wiring connected to the load cell or junction box (if one is used).

---