

HIGH-SPEED, HIGH-RESOLUTION DATA ACQUISITION SYSTEM

Key Features:

- ❖ Commercially Of The Shelf (COTS) Solution using the latest FPGA and GPU computing technologies
- ❖ Rackmount host server with multi-socket high density core CPU and high-capacity RAM
- ❖ Four 4-channel ADCs with Kintex FPGA PCIe boards
- ❖ Optional GPU Processing board for signal processing
- ❖ Cybersecurity-compliant Operating System (OS) hardened with security patches/policies
- ❖ Control software and hardware drivers continuously updated to meet cybersecurity requirements on the OS
- ❖ Graphical User Interface provided

Specifications:

- ❖ Four independent 4-channel or sixteen synchronized analog to digital channels (ADC)
- ❖ 16-bit resolution, 200 MHz sampling rate ADC
- ❖ Software or external sampling trigger/gate
- ❖ Internal or external sampling / reference clock
- ❖ Wideband Digital Down-conversion
- ❖ Variable sampling decimation with user-selectable/loadable FIR
- ❖ Sixteen independent interrupt-triggered digital input/output channels

Application:

- ❖ Radar Applications: Including MIT/LL's Radar Open System Data Sampling System
- ❖ High speed data collection

PCIe FPGA ADC BOARD

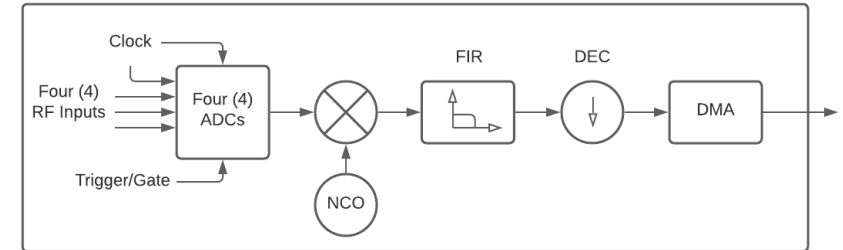

High Performance
Data Acquisition System



DISA-STIGs & Nessus Scan Cybersecurity Compliant
COTS, FPGA, RHEL 8 OS, Modern Technology

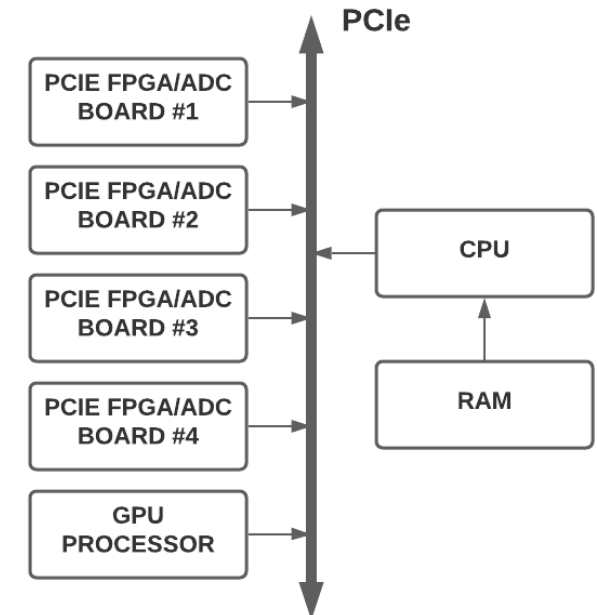

info@onboresighteng.com § www.onboresighteng.com § 808 378 4212

2970 Haleko Road, Suite #105, Lihue, HI 96766