

ONCE YOU CHOP,
YOU CAN'T STOP!
ONCE YOU CHOP,
YOU CAN'T STOP!



Company Profile



Welcome

We're thrilled to introduce you to our brand—a place where quality meets innovation, and where every bite tells a story.

We invite you to take a moment to learn about our journey, the values that drive us, and the exciting opportunities we offer for growth and partnership. Whether you're considering a franchise or looking for a unique business venture, we're excited to show you why Chops to Go is the perfect choice.

Let's explore the possibilities together!

Chops to Go[®]

Table of Contents

03

ABOUT US

Brief background about our company

05

WHY CHOOSE CHOPS TO GO?

What makes our brand truly unique in the market?

08

CORPORATE SOCIAL RESPONSIBILITY

Our community involvement

10

OUR CLIENTS

Diverse clientele, from schools to malls

11

OUR PRODUCTS

High-quality, locally sourced chicken chops and potato chips

15

MARKET STRATEGIES

Franchising, reseller, and distributorship opportunities

17

FRANCHISE PACKAGE

Comprehensive setup for quick profitability

19

SPECIAL OFFER

Exclusive deals for multi-branch investments

22

STEPS TO OWNERSHIP

Simple process to franchise success

25

DISTRIBUTORSHIP/EXPORT

We are open for distributorship

29

FUTURE PLANS

Expansion to new markets and innovations

31

CERTIFICATIONS & PERMIT

Halal-certified and FDA-approved operations



About us

We began with a simple yet ambitious vision: to offer unique and authentic snack experience that resonates with Filipino tastes while embracing global inspiration. Over the years, we've grown into a well-loved brand with multiple branches, each upholding our core values of quality, innovation, and community support.

What started as a small venture quickly gained traction, thanks to the loyalty of our customers and our dedication to quality.

Chops to Go was launched in 2017 at the Franchise & Business Expo of the Association of Filipino Franchisers Inc in World Trade Center, Manila. Chops to Go brand specializes in chicken chops rice meal, chicken chops with chips, jumbo chicken, and chicken burger with milk tea on the sides. Today, our branches are located in Katipunan Avenue, SM food court malls in Metro Manila, Dasmarias Cavite, Nueva Ecija, and Zamboanga.

OUR PARTNERS



Once you chop, you can't stop!



Our experiences throughout the years molded our intuition and capabilities to understand our customers' tastes and satisfaction and will continue to create not just delighting mixed drink and meals but also delicious treats in the months to come.

We aspire to be a globally competitive franchising company and hopes to be not just a franchisor but a company with integrity.

Pandemic came and the company was able to innovate and launch CHOPS TO GO's Fresh Potato Chips in foil packs and in tubs with longer shelf lives. Thus, **CTG FOOD CORP** was born.



Why Choose Chops to Go?

Unique Products

Inspired Globally, Crafted for Filipinos:

Our chicken chops are inspired by Taiwanese street food but are crafted to suit the Filipino palate. This fusion of authenticity and adaptation makes our product truly unique in the market.

A Healthier Snack Alternative: Our fresh potato chips stand out in a market dominated by processed foods. It's made with real, locally sourced potatoes and contains no unnecessary additives, making it a guilt-free snack. Each chip is handcrafted to preserve the authentic taste of potatoes



Commitment to Quality



RP1 Radyo Pilipinas News Interview: On DOST's Support for MSMEs in Product Development, June 07, 2024

We have worked closely with both DOST-NCR and the FDA to enhance our product. Through these collaborations, we have been able to select top-notch equipment and guarantee that our every step upholds the highest standards. Our commitment to quality not only ensures customer satisfaction but also reflects our integrity as a company.

Growing Brand Recognition

To further promote our products, we actively participate in different events such as Nakakalokal. This initiative, launched by PhilStar Media Group in collaboration with SM Supermalls aims to give spotlight to Filipino creativity, innovation, and expertise, as well as recognize the valuable role of MSMEs in the Philippine economy.

In recognition to our participation in this event, we are honored that our brand received the esteemed **NAKAKABIGHANI AWARD** at the NAKAKABAZAAR 2024: The Grand Nakakalokal Fair held at SM City Clark on April 28, 2024.



NAKAKABAZAAR 2024 at the SM City Clark, April 28, 2024

We are proud to have been featured in several TV appearances and interviews, which have significantly increased our visibility and demonstrated our potential to become a major player in the food industry.

Our media appearances and award are just the beginning. As we gain more recognition, the value of the Chops to Go brand will continue to rise.





Awarding of Halal Certification - August 06, 2024

Halal Awarding



We believe that great food should not only taste good but also make a positive impact on the community.

We at Chops to Go, are proud to support Filipino farmers by sourcing our chicken and potatoes locally. By doing so, we ensure that our products are fresh and of the highest quality, while also contributing to the growth of the local economy.

Our recent Halal certification is a reflection of our commitment to inclusivity and quality. This certification ensures that our products are friendly to all customers, regardless of their religious beliefs, and aligns with our core values of serving everyone.



Corporate Social Responsibility



Medical Mission at Antipolo, September 06, 2023

As an entrepreneur in the food and beverage industry, Ms. Joyce Co Yu has led groundbreaking initiatives that have driven the brands forward. This includes introducing pioneering coffee and milk tea options, unique menu items, and venturing into new markets. Additionally, she is committed to community involvement through various corporate social responsibility projects, using her platform to create a positive influence and motivate others to follow suit.

With a BS in Medical Technology, bloodletting has become second nature to her, playing a pivotal role in her company's corporate social responsibility efforts. Furthermore, her service in the Philippine Air Force has ignited her passion for organizing extensive medical and dental missions to serve communities in need.

Leading with Purpose

Ms. Yu is a beacon of entrepreneurial excellence in the Filipino business landscape. As the visionary behind Trueblends and Chops to Go, her journey is a testament to resilience, innovation, and a relentless pursuit of quality. On March 2024, she was recognized as one of the Inspiring Filipina Entrepreneurs at the Women's Summit 2024, presented by Go Negosyo, this accolade highlights her impactful contributions to the entrepreneurial community.

In addition to her achievements, Ms. Yu serves as a Go Negosyo Mentor, guiding fellow MSMEs on their path to success and fostering a culture of growth and empowerment.



Lab for All - A project of the First Lady of the Republic of the Philippines - Ms. Louise Araneta - Marcos in Partnership with Go Negosyo, Quezon City, August 01, 2024



Women's Summit at the Ayala Mall, Manila Bay, Parañaque City, March 09, 2024





Our Clients

Ateneo de Manila High School

ADMU, Gonzaga

Congressman Allan Reyes' Office

Philippine Commission on Women

Joneco Marketing Technology Corp

Trumed Healthcare Corp

Hexagon Chemical Corporation

Cebuana Lhuillier

Resorts World Manila

Quezon City LGU

ADMHS Coop., Ms. Cristine Natividad

ADMU Cooperative

Congressman Allan Reyes

Chairperson Sandy Montano

Ms. Aileen Tamadora

Ms Darlene Pepito

Ms. Grethel

Daryl/Jennie

Ms. Kathy Mercado

Ms Mona Yap

ChopstoGo[®]



Our Products



CHICKEN CHOPS ALA CARTE

Juicy, tender chicken chops seasoned to perfection, ready to be enjoyed on their own.



CHICKEN CHOPS WITH CHIPS

Our signature chicken chops paired with crispy, golden potato chips for a satisfying combo.



FISH FILLET WITH CHIPS

Crispy fish fillet with crunchy chips, a classic savory delight.

MAKE IT A COMBO

Enjoy your snack with our signature House Blend Iced Tea and Milk Tea

House Blend Iced Tea



Milk Tea



Chicken Chops Ala Carte & Pearl Milk Tea



Chicken Chops with Chips & Pearl Milk Tea

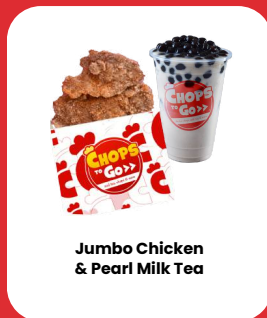

Jumbo Chicken & Pearl Milk Tea



Fish Fillet with Chips & Pearl Milk Tea



Chicken Fingers & Pearl Milk Tea



Chicken Chops Ala Carte & Iced Tea



Chicken Chops with Chips & Iced Tea

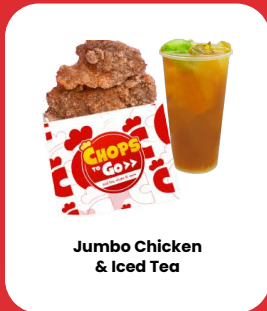

Jumbo Chicken & Iced Tea



Fish Fillet with Chips & Iced Tea



Chicken Fingers & Iced Tea



JUMBO CHICKEN ALA CARTE

A generous portion of juicy, flavorful chicken perfect for a satisfying meal.



CHICKEN FINGERS

Crispy on the outside, tender on the inside—our chicken fingers are the perfect snack or meal.



REFRESHING DRINKS

Quench your thirst with our signature House Blend Iced Tea and Milk Tea.

CHICKEN CHOPS

TAIWAN'S BITE-SIZE CHICKEN CHOPS!

RM 11.50



CHICKEN CHOPS ALA CARTE

RM 7.30



CHICKEN CHOPS WITH CHIPS

RM 8.50



FISH FILLET WITH CHIPS

COMBO MEALS



SET A

RM 12.35

Chops w/ Chips and Pearl Milktea



SET B

RM 12.73

Jumbo Chicken with Pearl Milktea



SET C

RM 13.50

Fish w/ Chips & Pearl Milk Tea

JUMBO CHICKEN

JUMBO CHICKEN SOLO

DIPS & FLAVORS

BBQ
SOUR CREAM
CHEESE
AIORI
SPICY AIOLI



P 99

FRESH POTATO CHIPS

SIZES

POUCH RM 17.68

TUB RM 35.14

FLAVORS

BBQ
SOUR CREAM
CHILI BBQ
SALTED EGG
WHITE CHEDDAR



ChopstoGo

FRESH POTATO CHIPS

made with real fresh potatoes



POUCH

120 GRAMS **SRP**

Regular Flavors **RM 17.68**

Premium Flavors **RM 18.45**

FLAVORS

Regular

BBQ
Chili BBQ
Sour Cream
Cheese
Salted
Plain

Premium

Salted Egg
White Cheddar
Pizza Supreme
Nori
Spicy Ramen
Lemon Pepper



JAR

160 GRAMS

Regular Flavors **RM 23.08**

Premium Flavors **RM 23.85**



TUB

280 GRAMS

Regular Flavors **RM 35.11**

Premium **RM 37.44**

For franchise, contact:

-  ChopstoGo
-  chopstogo_official
-  chopstogofranchising@gmail.com
-  <https://trueblends.com.ph/>



ORDER NOW

Market Strategies



Marketing Strategies

Franchising



As a Chops to Go franchisee, you will be joining a brand that has already proven its appeal and potential. Here's what we offer:



Proven Business Model

Our operations are streamlined and efficient, allowing for easy replication in new locations.



Training and Support

We provide extensive training on our products, preparation methods, and customer service standards.



Exclusive Territory Rights

To ensure that our franchisees have the best chance of success, we offer exclusive territory rights.



Marketing & Promotional Assistance

Our team will work closely with you to develop marketing strategies tailored to your location.



Site Selection Support

Offer assistance in selecting the best locations for new branches, through our pre-approved locations



No Royalty Fees

Our franchise package offers you the freedom to maximize your earnings with no royalty fees.



Standard

Franchise Package

This package is tailored for high-traffic locations such as schools, offices, and malls.

Package Inclusions

Cart *with lighted signage*

Deed Fryer

Food Warmer

Rice Cooker

Range Hood

Chest Type Freezer

Complete Kitchen Utensils

Staff Uniforms

Initial Stocks Worth RM 2,700

Operations Manual

Investment Amount

RM **38**K

Initial Term

3

years

Product Line

All Chops to Go products

*Additional RM 1.5k to include Milk Tea ingredients



Why Choose this package?



Turnkey Solution: It has everything you need to start earning from day one.

Strategic Placement: Ideal for high-foot traffic areas, ensuring maximum visibility and sales

Proven Business Model: With our established brand, strong customer base, and efficient operational model, you're investing in a business that's set up for success



*appearance of the official cart



Special Offer

Master Franchise

We're offering a special package for those interested in opening multiple Chops to Go branches. This limited-time offer is ideal for expanding into multiple locations at once, such as opening branches in different areas of a city or region.

Limited Time Offer

Standard Package

RM 38K



Special Franchise Package

RM 28K



All Standard Package inclusions except the Cart

5

Chops to Go Branches



Investment Amount

RM **140^K**

5 Chops to Go Branches

Initial Term

5

years

Product Line

**All Chops to Go
products**

*Additional RM 1.5k to include Milk Tea ingredients

Why Choose this package?



Cost-Effective

At a reduced price, this package offers tremendous value for the investment, making it an ideal choice for those looking to expand quickly.

Flexible Formats

Without the cart, you gain the flexibility to design your branch to fit your unique vision—whether it's a kiosk, food truck, or full-fledged outlet—to fit your space and budget.

Limited Time Offer

This special offer is available for a limited time, making it an exclusive opportunity to get ahead of the competition.

Steps to Ownership





Marketing Strategies

Resellers

Our potato chips are widely available through resellers across Metro Manila, including Quezon City, Pasay, Pasig, and Manila, making our snacks accessible to a growing customer base.



The Grove by Rockwell, Pasig



Loyola Grand Villa, Quezon City



Sentosia Condominium, Parañaque

Distributorship

Our potato chips are widely available through resellers across Metro Manila, including Quezon City, Pasay, Pasig, and Manila, making our snacks accessible to a growing customer base.

Convenience Stores, & Groceries, & Restaurants



Shell Select Stores



KR Express Convenience Store
NAIA Terminal 3



Ro's Steak & Seafood



Quincy Supermarket



Bing's Deli



True Blends - Cafe Katipunan





WE'RE OPEN FOR DISTRIBUTORS

Kami bukas untuk pengedar!



Are you looking for new
business opportunity?

Adakah anda sedang mencari yang baru **peluang perniagaan?**

For inquiries, you may contact:
Untuk pertanyaan boleh hubungi:



+63 960-854-9316
+63 917-884-5566



ctgfoodcorp@gmail.com
chopstogofranchising@gmail.com



Scan the QR for
more information

Contact us!
Hubungi Kami!



Chops to Go



@chopstogo_official



www.trueblends.com.ph

EXPORT DETAILS

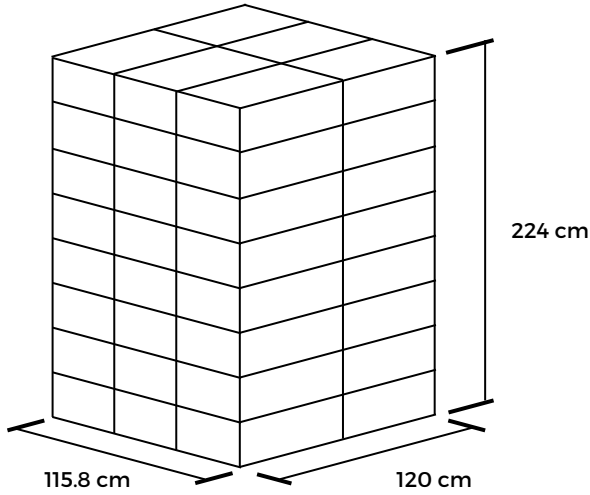

48 Boxes of Chips

No. of Boxes:	48 Boxes
No. of Layers:	8 Layers
No. of Pouches per box	960 pcs

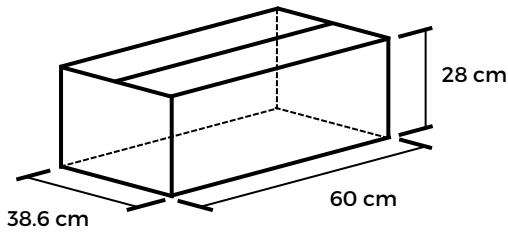

Corrugated Brown Box

1 Box of Chips

Dimension:	28x38.6x60 cm
No. of Pouches:	20 pcs



Standard 20ft Container

1 Standard 20ft Container

Container Size:	Standard 20ft
External:	6.06x2.44x2.59
Internal:	5.9x2.35x2.39
No. of Boxes:	480
Est. No. of Pouches:	9,600 pcs

EXPORT DETAILS

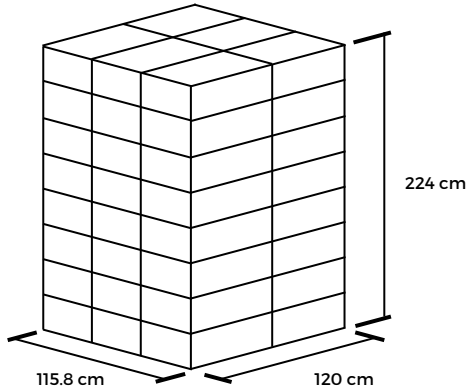

48 Boxes of Chips

48 boxes x 20 pcs Pouches 120g

Regular Flavors	\$2,832
Premium Flavors	\$3005

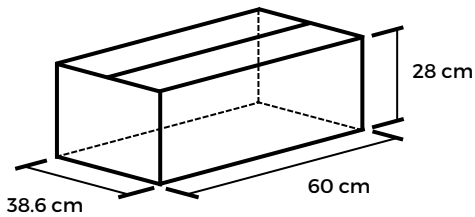

1 Box of Chips

20 pcs of Pouch 120g

Regular Flavors	\$59
Premium Flavors	\$63



1 Standard 20ft Container

9,600 pcs of Pouch 120g

Regular Flavors	\$28,320
Premium Flavors	\$30,048

Available Flavors

Regular Flavors **\$2.95**

BBQ

Chili BBQ

Sour Cream

Premium Flavors **\$3.13**

White Cheddar

Delivery and Payment

Delivery: 30 Days

MOQ: 240 Boxes

= 4,800 Pouches

Payment: Cash on Delivery

EXPORT DETAILS

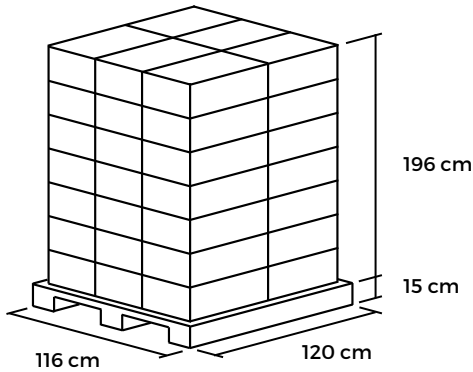

1 Pallet

42 boxes x 20 pcs Pouches 120g

Regular Flavors	\$2,832
Premium Flavors	\$3005

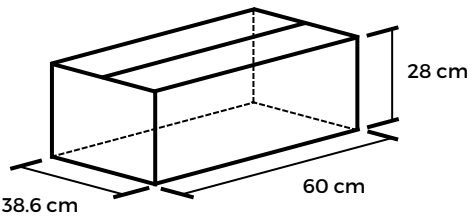

1 Box of Chips

20 pcs of Pouch 120g

Regular Flavors	\$59
Premium Flavors	\$63



1 Standard 20ft Container

9,600 pcs of Pouch 120g

Regular Flavors	\$28,320
Premium Flavors	\$30,048

Available Flavors

Regular Flavors **\$2.95**

BBQ

Chili BBQ

Sour Cream

Premium Flavors **\$3.13**

White Cheddar

Delivery and Payment

Delivery: 30 Days

MOQ: 240 Boxes
= 4,800 Pouches

Payment: Cash on Delivery

FRESH POTATO CHIPS

PACKAGING SPECIFICATIONS

	PRIMARY	SECONDARY
Pack Size	120g	20 pouches x 120g
Packaging Material	Foil Stand Up Pouch	Brown Corrugated Box
Condition of Packaging	Glossy finish pouch with resealable zipper, nitrogen sealed, and with print. Size: 15x7.6x28cm	Brownkraft Size: 28x38.6x60 cm
Label Declaration		
Product Name	CHOPS TO GO FRESH POTATO CHIPS	
Manufacturing Date	DDMMYY	
Expiration Date	DDMMYY	
Lot No.	XXXX	
Net Weight (Primary)	120g	
Net Weight (Secondary)	20 pouches x 120g	
Storage	Stored at room temperature, clean, cool and dry place	
Manufacturing Details	129 Kalandang, Barrio San Jose, Caloocan City, Philippines	

SHELF LIFE AND STORAGE CONDITION

Shelf-Life	6 months from the manufacturing date
Storage Condition	Stored at room temperature, Keep in a clean, cool and dry place

Future Plans

Expanding Franchise Opportunity

By targeting strategic locations and offering flexible franchise formats, we aim to make our brand more accessible to potential partners and customers worldwide.

Exporting

As we continue to gain recognition in the local market, we're preparing to bring the authentic taste of our chicken chops and natural potato chips to the global stage.

Product Innovation

We plan to introduce new flavors, healthier options, and seasonal products that cater to changing consumer preferences, ensuring that our offerings remain fresh, exciting, and relevant.



Together, let's bring on the go meals

Worldwide

We invite you to be part of our journey. Together, we can bring the unique flavors of Chops to Go to new markets. **Let's make a difference, one delicious bite at a time.**



Certifications & Permits

 **REPUBLIC OF THE PHILIPPINES
SECURITIES AND EXCHANGE COMMISSION**
The SEC Headquarters
7907 Makati Avenue, Salcedo Village,
Barangay Bel-Air, Makati City, 1209, Metro Manila



COMPANY REG. NO.: 2023050101264-07

CERTIFICATE OF INCORPORATION

KNOW ALL PERSONS BY THESE PRESENTS:
This is to certify that the Articles of Incorporation and By Laws of:

CTG FOOD CORP.

were duly approved by the Commission on this date upon the issuance of this Certificate of Incorporation in accordance with the Revised Corporation Code of the Philippines (Republic Act No. 11232), which took effect on February 23, 2019 and copies of said Articles of Incorporation and By Laws are hereto attached.

This Certificate grants juridical personality to the corporation but does not authorize it to issue, sell or offer for sale to the public, securities such as but not limited to, shares of stock, investment contracts, debt instruments and virtual currencies without prior Registration Statement approved by the Securities and Exchange Commission; nor to undertake business activities requiring a Secondary License from this Commission such as, but not limited to acting as: broker or dealer in securities, government securities eligible dealer (GSED), investment adviser of an investment company, close-end or open-end investment company, investment house, transfer agent, commodity/financial futures exchange/broker/merchant, financing/lending company, and time shares/club shares/membership certificate issuers or selling agents thereof; nor to operate a fiat money to virtual currency exchange. Neither does this Certificate constitute a permit to undertake activities for which other government agencies require a license or permit.

This Certificate DOES NOT AUTHORIZE INVESTMENT SOLICITATION AND INVESTMENT-TAKING WITHOUT A SECONDARY LICENSE FROM THIS COMMISSION.

As a registered corporation, it shall submit annually to this Commission the reports indicated at the back of this certificate.

IN WITNESS WHEREOF, I have hereunto set my hand and caused the seal of this Commission to be affixed to this Certificate at The SEC Headquarters 7907 Makati Avenue, Salcedo Village, Barangay Bel-Air, Makati City, 1209, Metro Manila, Philippines, this day of 30 May Two Thousand Twenty Three.

GERARDO F. DEL ROSARIO
Director
Company Registration and Monitoring Department

*This is a computer generated certificate,
signature is not required.*

For SEC use only
C107 (PSIC as reserved)
Stock Corporation
Less Than 5 Incorporators

DOCUMENTARY STAMP TAX PAID



Republic of the Philippines
Department of Health
Food and Drug Administration
Civic Drive, Filinvest Corporate City
Alabang, Muntinlupa City



LICENSE TO OPERATE

Food Manufacturer

is hereby granted to

CTG FOOD CORP.

129 Kalandang Street, Bo. San Jose, Brgy. 127, Dist. 2,, Caloocan, Metro
Manila

Owner: **CTG FOOD CORP.**
License Number: **CFRR-NCR-FM-708458**
Application Type: **Initial**
Additional Activities: **Exporter of Own Products**
Date of Issuance: **03 January 2024**
Validity of License: **03 January 2026**



This LTO shall be renewed within **90 days** before its expiration, upon compliance with relevant laws, rules and regulations and the payment of fees. This LTO may be suspended, cancelled or revoked by this Office for cause if found violating RA 9711 and related issuances.

Furthermore, with this LTO, the FDA allows the establishment to apply for a market authorization [i.e. registration (CPR) or notification] for health products prior to manufacture, importation, sale or offer for sale, distribution, transfer and advertisement as the case may be.

DR. SAMUEL A. ZACATE

Director General

This electronic-LTO (eLTO) is computer generated and does not require signature

منظمة مؤتمر العلماء بالفلبين

PHILIPPINE ULAMA CONGRESS ORGANIZATION, INC.

SEC. REG. NO. CN200520263
Excellence. Partnership. Service.



HALAL CERTIFICATE

This is to certify that the product(s) described below are produced in accordance with Islamic guidelines and are therefore lawful and fit for Muslim consumption.

Product variants(s): **Chops to Go Fresh Potato chips, with flavors;**

1. Barbeque
2. Sour Cream
3. Plain
4. Salted
5. Chili BBQ
6. White Cheddar
7. Nori (Dried Seaweed)
8. Spicy Ramen
9. Salted Egg
10. Ketchup
11. Pizza Supreme
12. Lemon Pepper



Brand Name: Fresh Potato Chips
Nature of Product: Food
Company Name: Chops to Go
Plant Address: 129 Kalandang St. Brgy. 127, Caloocan City Philippines

This Certificate bearing **Control No. 24-07-01NFP08C01R-060824** is valid for a period of **THREE (3) years**, effective from **6th day of August, 2024** to **5th day of August, 2027**, subject to the provisions in the **Halal Certification and Monitoring Agreement (HCMA)**.



LUQMAN A. BIN USMAN IMAM, MAIS, SCL
President

BIR FORM
2303

REVISED: APRIL 2019

REPUBLIKA NG PILIPINAS
KAGAWARAN NG PANANALAPI
KAWANIHAN NG RENTAS INTERNAS
REVENUE REGION NO. 005 - CALOOCAN CITY
REVENUE DISTRICT OFFICE NO. 027 - CALOOCAN CITY

OCN: 027RC2023000004477

Date OCN Generated: June 16, 2023

CERTIFICATE OF REGISTRATION

TIN & BRANCH CODE 628-325-419-00000	NAME OF TAXPAYER CTG FOOD CORP.	TIN ISSUANCE DATE June 16, 2023		
REGISTERING OFFICE REGISTERED ADDRESS 129 KALANDANG ST. BARANGAY 127 1400 CALOOCAN CITY NCR, THIRD DISTRICT PHILIPPINES	Head Office	Branch		
TAX TYPES CORPORATE INCOME TAX CORPORATE INCOME TAX PERCENTAGE TAX - QUARTERLY WITHHOLDING TAX - COMPENSATION WITHHOLDING TAX - COMPENSATION WITHHOLDING TAX - EXPANDED/OTHERS WITHHOLDING TAX - EXPANDED/OTHERS WITHHOLDING TAX - EXPANDED/OTHERS REGISTRATION FEE TAXPAYER TYPE/S	FORM TYPES 1702 1702Q 2551Q 1601C 1604C 0819E 1601EQ 1604E 0605	FILING DATE January 1, 2024 July 1, 2023 July 1, 2023 July 1, 2023 January 1, 2024 January 1, 2024 July 1, 2023 July 1, 2023 January 1, 2024 January 1, 2024	FILING FREQUENCY ANNUALLY QUARTERLY QUARTERLY MONTHLY ANNUALLY MONTHLY QUARTERLY ANNUALLY ANNUALLY	FILING DUE DATE On or before the 15th day of the 4th month following the close of the taxpayer's taxable year. Within sixty (60) days following the close of each of the first three (3) quarters of the taxable year. Within twenty five (25) days after the end of each taxable quarter On or before the 10th day of the month following the month when the withholding was made except for taxes withheld for December which shall be filed and paid/remitted on or before January 15 of the succeeding year. On or before January 31 of the year following the calendar year in which the compensation payment and other income payments were paid or accrued. On or before the 10th day of the month following the month in which withholding was made. Not later than the last day of the month following the close of the quarter during which withholding was made. On or before March 1 of the year following the calendar year in which the income payments subject to expanded withholding taxes of exempt from withholding tax were paid or accrued. On or before the last day of January

BIR FORM
2303
REVISED: APRIL 2019

REPUBLIKA NG PILIPINAS
KAGAWARAN NG PANANALAPI
KAWANIHAN NG RENTAS INTERNAS
REVENUE REGION NO. 005 - CALOOCAN CITY
REVENUE DISTRICT OFFICE NO. 027 - CALOOCAN CITY

OCN: 027RC202300000477
Date OCN Generated: June 16, 2023

CERTIFICATE OF REGISTRATION

TIN & BRANCH CODE 628-325-419-00000	NAME OF TAXPAYER CTG FOOD CORP.	TIN ISSUANCE DATE June 16, 2023
REGISTERING OFFICE 129 KALANDANG ST BARANGAY 127 1400 CALOOCAN CITY NCR, THIRD DISTRICT PHILIPPINES	X Head Office	Branch

BUSINESS INFORMATION DETAILS		CATEGORY	REGISTRATION DATE
TRADE NAME 1 (PSIC)	CTG FOOD CORP. 10789-MANUFACTURE OF FOOD PRODUCTS, N.E.C.	Primary	June 16, 2023
Line of Business	MANUFACTURE OF FOOD PRODUCTS SUCH AS POTATO CHIPS, CURLS AND OTHER FOOD PRODUCTS		

REMINDERS:

1. An annual registration fee shall be paid upon registration and every year thereafter on or before the last day of January, using BIR Form No. 0605.
2. Filing of required tax returns to conform with the above tax types, whether with or without business operation, to avoid penalties.
3. For new business registrants, application for registration of manual Books of Accounts (B/As) shall be before the deadline for filing of the initial quarterly income tax return or annual income tax return whichever comes earlier, from the date of registration. Registration of new set of manual B/As shall be before its use.
4. Immediately inform the district office in case of transfer/cessation of business and other changes in registration information by filing BIR Form No. 1905.
5. For Self-Employed Individuals (SEI) whose gross sales and/or receipts and other non-operating income does not exceed P3,000,000 and who opted to avail of the 8% Income tax rate, the tax type Percentage Tax (PT) shall not be reflected in the Certificate of Registration (COR). However, at the start of each taxable year, such SEI shall be automatically subjected to graduated income tax rates and required to file quarterly percentage tax return (BIR Form No. 2551Q) and option to replace the COR to reflect "PT", unless qualified and opted to avail of the 8% Income tax rate annually.

I hereby certify that the above named person is registered as indicated above, under the provision of the National Internal Revenue Code, as amended.



ATTY. ELISEO RAUL G. BACALZO
ASST. REVENUE DISTRICT OFFICER

FRITZ S. BUENDIA

OIC - REVENUE DISTRICT OFFICER
(Signature over Printed Name)

THIS CERTIFICATE MUST BE EXHIBITED CONSPICUOUSLY IN THE PLACE OF BUSINESS.



Republic of the Philippines
CITY OF CALOOCAN
CALOOCAN HEALTH DEPARTMENT
SANITATION DIVISION



SANITARY PERMIT

No. 23-M0710-00006 2024



Is hereby granted to

CTG FOOD CORPORATION
OWNER / MANAGER

WHOLESALER
KIND OF BUSINESS

CTG FOOD CORPORATION
BUSINESS NAME

129 KALANDANG ST., BO. SAN JOSE, BRGY. 127, DIST.2,
CALOOCAN CITY
ADDRESS

NEW

RENEWAL

Date Issued: January 20, 2024

Date Expired: 12/31/2024

O.R. No: 1916125

Amount: PHP 1,079.00

PLEASE DISPLAY THIS PERMIT WHERE IT CAN BE SEEN.

GUIDELINES

1. The owner/manager is responsible for the health and safety of the individual workers;
2. Any worker/employee shall not be allowed to work without a health certificate.
3. Upon presentation of proper credentials, sanitary inspectors shall at any reasonable time be allowed entry into premises for the purpose of inspection/enforcement of the Code;
4. This permit must be presented upon inspection to an authorized health personnel;
5. The establishment shall comply with all existing laws, regulations, rules, ordinances and sanitation requirements of PRESIDENTIAL DECREE No. 856 (Code on Sanitation of the Philippines).

ANY VIOLATION OF THE ABOVE GUIDELINES SHALL RESULT TO THE REVOCATION OF THE SANITARY PERMIT.

RECOMMENDED BY:

DONNA ROSE M. MATULAC, MD
OIC, Sanitation Services Division

APPROVED BY:

emacuevas
EVELYN ONG-CUEVAS, MD, MPH, MHA
OIC, City Health Department

UNA ANG KALUSUGAN KAY **Mayor Along Malapitan**



Complete Address & Contact Details

Registered Business Name: CTG Food Corp

Name of Owner: Marie-Joyce Co Yu

Contact Details: +63 917 884 5566

Office Address: 3rd Floor, 129 Kalandang Street, San Jose, Caloocan, Philippines



All rights reserved 2024